



**THE DATASHEET OF
TPS62000QDGSRQ1**



**TPS62000-Q1, TPS62001-Q1, TPS62002-Q1, TPS62003-Q1
TPS62004-Q1, TPS62005-Q1, TPS62006-Q1, TPS62007-Q1, TPS62008-Q1
HIGH-EFFICIENCY STEP-DOWN LOW POWER DC-DC CONVERTER**

SGLS243A – APRIL 2004 – REVISED JUNE 2008

FEATURES

- Qualified for Automotive Applications
- High-Efficiency Synchronous Step-Down Converter With Greater Than 95% Efficiency
- 2-V to 5.5-V Operating Input Voltage Range
- Adjustable Output Voltage Range From 0.8 V to V_I
- Fixed Output Voltage Options Available in 0.9 V, 1 V, 1.2 V, 1.5 V, 1.8 V, 1.9 V, 2.5 V, and 3.3 V
- Synchronizable to External Clock Signal up to 1 MHz
- Up to 600-mA Output Current
- Pin-Programmable Current Limit
- High Efficiency Over a Wide Load Current Range in Power Save Mode
- 100% Maximum Duty Cycle for Lowest Dropout

- Low-Noise Operation Antiringing Switch and PFM/PWM Operation Mode
- Internal Softstart
- 50- μ A Quiescent Current (TYP)
- Available in the 10-Pin Microsmall Outline Package (MSOP)
- Evaluation Module Available

APPLICATIONS

- Low-Power CPUs and DSPs
- Cellular Phones
- Organizers, PDAs, and Handheld PCs
- MP-3 Portable Audio Players
- Digital Cameras
- USB-Based DSL Modems and Other Network Interface Cards

description/ordering information

The TPS6200x devices are a family of low-noise synchronous step-down dc-dc converters that are ideally suited for systems powered from a 1-cell Li-ion battery or from a 2- to 3-cell NiCd, NiMH, or alkaline battery. The TPS6200x operates typically down to an input voltage of 1.8 V, with a specified minimum input voltage of 2 V.

ORDERING INFORMATION†

T_J	VOLTAGE OPTIONS	MSOP PACKAGE‡	MARKING
-40°C to 125°C	Adjustable	TPS62000QDGSRQ1	AOQ
	0.9 V	TPS62001QDGSRQ1§	
	1 V	TPS62002QDGSRQ1§	
	1.2 V	TPS62003QDGSRQ1§	
	1.5 V	TPS62004QDGSRQ1	AOR
	1.8 V	TPS62005QDGSRQ1	ALY
	1.9 V	TPS62008QDGSRQ1§	
	2.5 V	TPS62006QDGSRQ1	AOS
	3.3 V	TPS62007QDGSRQ1	AOT

† For the most current package and ordering information, see the Package Option Addendum at the end of this document, or see the TI web site at <http://www.ti.com>.

‡ Package drawings, thermal data, and symbolization are available at <http://www.ti.com/packaging>.

§ Indicates Product Preview. Contact Texas Instruments for details.



Please be aware that an important notice concerning availability, standard warranty, and use in critical applications of Texas Instruments semiconductor products and disclaimers thereto appears at the end of this data sheet.

UNLESS OTHERWISE NOTED this document contains PRODUCTION DATA information current as of publication date. Products conform to specifications per the terms of Texas Instruments standard warranty. Production processing does not necessarily include testing of all parameters.



POST OFFICE BOX 655303 • DALLAS, TEXAS 75265

Copyright © 2008, Texas Instruments Incorporated

**TPS62000-Q1, TPS62001-Q1, TPS62002-Q1, TPS62003-Q1
 TPS62004-Q1, TPS62005-Q1, TPS62006-Q1, TPS62007-Q1, TPS62008-Q1
 HIGH-EFFICIENCY STEP-DOWN LOW POWER DC-DC CONVERTER**

SGLS243A – APRIL 2004 – REVISED JUNE 2008

description (continued)

The TPS6200x is a synchronous current-mode PWM converter with integrated N- and P-channel power MOSFET switches. Synchronous rectification is used to increase efficiency and to reduce external component count. To achieve the highest efficiency over a wide load current range, the converter enters a power-saving pulse-frequency modulation (PFM) mode at light load currents. Operating frequency is typically 750 kHz, allowing the use of small inductor and capacitor values. The device can be synchronized to an external clock signal in the range of 500 kHz to 1 MHz. For low-noise operation, the converter can be operated in the PWM mode and the internal antiringing switch reduces noise and EMI. In the shutdown mode, the current consumption is reduced to less than 1 μ A. The TPS6200x is available in the 10-pin (DGS) microsmall outline package (MSOP). The devices operate over a junction temperature range of -40°C to 125°C .

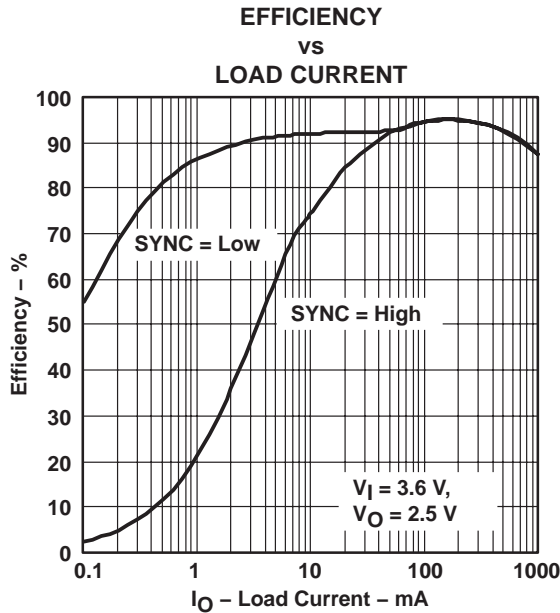
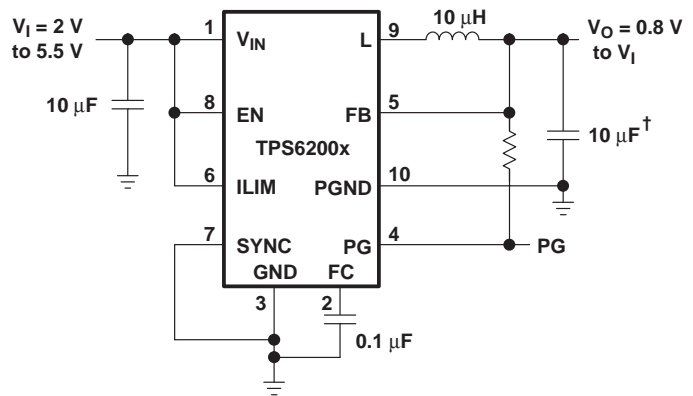
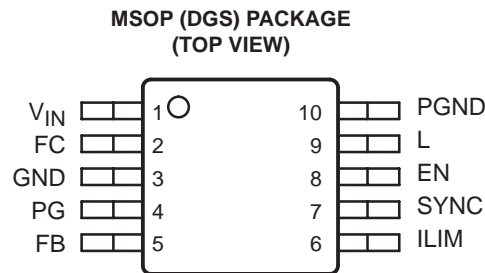

Figure 1



[†] With V_O \geq 1.8 V; C_O = 10 μ F, V_O < 1.8 V; C_O = 47 μ F

Figure 2. Typical Application Circuit for Fixed Output Voltage Option



**TPS62000-Q1, TPS62001-Q1, TPS62002-Q1, TPS62003-Q1
TPS62004-Q1, TPS62005-Q1, TPS62006-Q1, TPS62007-Q1, TPS62008-Q1
HIGH-EFFICIENCY STEP-DOWN LOW POWER DC-DC CONVERTER**

SGLS243A – APRIL 2004 – REVISED JUNE 2008

functional block diagram

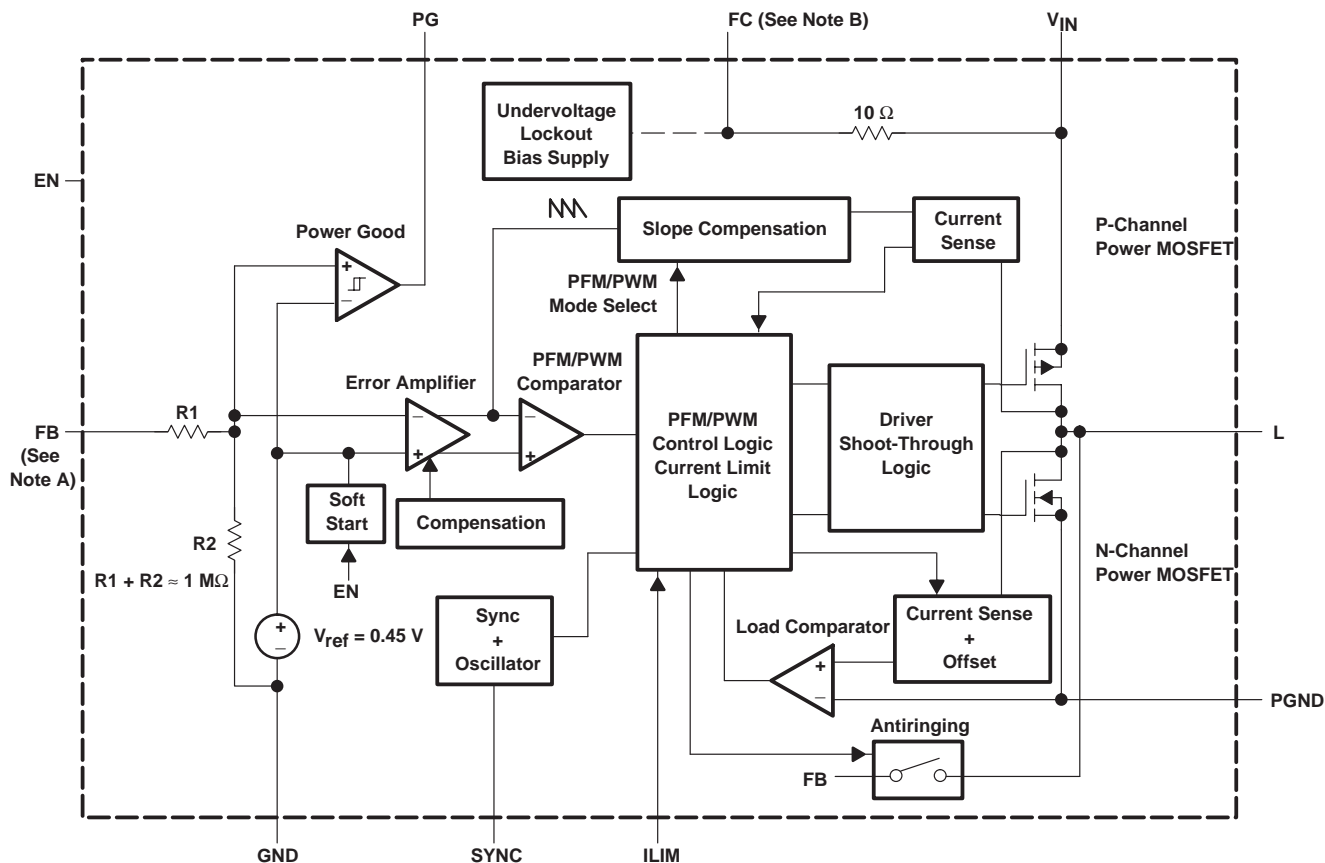

- NOTES: A. The adjustable output voltage version does not use the internal feedback resistor divider. The FB pin is directly connected to the error amplifier.
B. Do not connect the FC pin to an external power source.

**TPS62000-Q1, TPS62001-Q1, TPS62002-Q1, TPS62003-Q1
 TPS62004-Q1, TPS62005-Q1, TPS62006-Q1, TPS62007-Q1, TPS62008-Q1
 HIGH-EFFICIENCY STEP-DOWN LOW POWER DC-DC CONVERTER**

SGLS243A – APRIL 2004 – REVISED JUNE 2008

Terminal Functions

TERMINAL NAME	NO.	I/O	DESCRIPTION
EN	8	I	Enable. A logic high enables the converter and a logic low forces the device into shutdown mode reducing the supply current to less than 1 μ A.
FB	5	I	Feedback pin for the fixed output voltage option. For the adjustable version, an external resistive divider is connected to FB. The internal voltage divider is disabled for the adjustable version.
FC	2		Supply bypass pin. A 0.1- μ F coupling capacitor should be connected as close as possible to this pin for good high frequency input voltage supply filtering.
GND	3		Ground
ILIM	6	I	Switch current limit. Connect ILIM to GND to set the switch current limit to typically 600 mA, or connect this pin to V_{IN} to set the current limit to typically 1200 mA.
L	9	I/O	Connect the inductor to this pin. L is the switch pin connected to the drain of the internal power MOSFETS.
PG	4	O	Power good comparator output. This is an open-drain output. A pullup resistor should be connected between PG and V_O . The output goes active high when the output voltage is greater than 92% of the nominal value.
PGND	10		Power ground. Connect all power grounds to PGND.
SYNC	7	I	Input for synchronization to external clock signal. Synchronizes the converter switching frequency to an external clock signal with CMOS level: SYNC = High: Low-noise mode enabled, fixed frequency PWM operation is forced SYNC = Low (GND): Power-save mode enabled, PFM/PWM mode enabled.
V_{IN}	1	I	Supply voltage input
NC			Not connected

detailed description

operation

The TPS6200x is a step down converter operating in a current mode PFM/PWM scheme with a typical switching frequency of 750 kHz.

At moderate to heavy loads, the converter operates in the pulse width modulation (PWM) and at light loads the converter enters a power save mode (pulse frequency modulation) to keep the efficiency high.

In the PWM mode operation, the device operates at a fixed frequency of 750 kHz. At the beginning of each clock cycle, the high side P-channel MOSFET is turned on. The current in the inductor ramps up and is sensed via an internal circuit. The high side switch is turned off when the sensed current causes the PFM/PWM comparator to trip when the output voltage is in regulation or when the inductor current reaches the current limit (set by ILIM). After a minimum dead time preventing shoot through current, the low side N-channel MOSFET is turned on and the current ramps down again. As the clock cycle is completed, the low side switch is turned off and the next clock cycle starts.

In discontinuous conduction mode (DCM), the inductor current ramps to zero before the end of each clock cycle. In order to increase the efficiency the load comparator turns off the low side MOSFET before the inductor current becomes negative. This prevents reverse current flowing from the output capacitor through the inductor and low side MOSFET to ground that would cause additional losses.

As the load current decreases and the peak inductor current does not reach the power save mode threshold of typically 120 mA for more than 15 clock cycles, the converter enters a pulse frequency modulation (PFM) mode.



**TPS62000-Q1, TPS62001-Q1, TPS62002-Q1, TPS62003-Q1
TPS62004-Q1, TPS62005-Q1, TPS62006-Q1, TPS62007-Q1, TPS62008-Q1
HIGH-EFFICIENCY STEP-DOWN LOW POWER DC-DC CONVERTER**

SGLS243A – APRIL 2004 – REVISED JUNE 2008

operation (continued)

In the PFM mode, the converter operates with:

- Variable frequency
- Constant peak current that reduces switching losses
- Quiescent current at a minimum

Thus maintaining the highest efficiency at light load currents. In this mode, the output voltage is monitored with the error amplifier. As soon as the output voltage falls below the nominal value, the high side switch is turned on and the inductor current ramps up. When the inductor current reaches the peak current of typical: $150 \text{ mA} + 50 \text{ mA/V} \times (V_I - V_O)$, the high side switch turns off and the low side switch turns on. As the inductor current ramps down, the low side switch is turned off before the inductor current becomes negative which completes the cycle. When the output voltage falls below the nominal voltage again, the next cycle is started.

The converter enters the PWM mode again as soon as the output voltage can not be maintained with the typical peak inductor current in the PFM mode.

The control loop is internally compensated reducing the amount of external components.

The switch current is internally sensed and the maximum current limit can be set to typical 600 mA by connecting ILIM to ground or to typically 1.2 A connecting ILIM to V_{IN} .

100% duty cycle operation

As the input voltage approaches the output voltage and the duty cycle exceeds typical 95%, the converter turns the P-channel high side switch continuously on. In this mode, the output voltage is equal to the input voltage minus the voltage drop across the P-channel MOSFET.

synchronization, power save mode and forced PWM mode

If no clock signal is applied, the converter operates with a typical switching frequency of 750 kHz. It is possible to synchronize the converter to an external clock within a frequency range from 500 kHz to 1000 kHz. The device automatically detects the rising edge of the first clock and is synchronizes immediately to the external clock. If the clock signal is stopped, the converter automatically switches back to the internal clock and continues operation without interruption. The switch over is initiated if no rising edge on the SYNC pin is detected for a duration of four clock cycles. Therefore, the maximum delay time can be 8 μs in case the internal clock has a minimum frequency of 500 kHz.

In case the device is synchronized to an external clock, the power save mode is disabled and the device stays in forced PWM mode.

Connecting the SYNC pin to the GND pin enables the power save mode. The converter operates in the PWM mode at moderate to heavy loads and in the PFM mode during light loads maintaining high efficiency over a wide load current range.

Connecting the SYNC pin to the V_{IN} pin forces the converter to operate permanently in the PWM mode, even at light or no load currents. The advantage is the converter operates with a fixed switching frequency that allows simple filtering of the switching frequency for noise sensitive applications. In this mode, the efficiency is lower compared to the power save mode during light loads (see Figure 1).

It is possible to switch from forced PWM mode to the power save mode during operation.

The flexible configuration of the SYNC pin during operation of the device allows efficient power management by adjusting the operation of the TPS6200x to the specific system requirements.



TPS62000-Q1, TPS62001-Q1, TPS62002-Q1, TPS62003-Q1 TPS62004-Q1, TPS62005-Q1, TPS62006-Q1, TPS62007-Q1, TPS62008-Q1 HIGH-EFFICIENCY STEP-DOWN LOW POWER DC-DC CONVERTER

SGLS243A – APRIL 2004 – REVISED JUNE 2008

low noise antiringing switch

An *antiringing* switch is implemented in order to reduce the EMI radiated from the converter during discontinuous conduction mode (DCM). In DCM, the inductor current ramps to zero before the end of each switching period. The internal load comparator turns off the low side switch at that instant thus preventing the current flowing backward through the inductance which increases the efficiency. An antiringing switch across the inductor prevents parasitic oscillation caused by the residual energy stored in the inductance (see Figure 12).

NOTE:

The *antiringing* switch is only activated in the fixed output voltage versions. It is not enabled for the adjustable output voltage version TPS62000.

soft start

As the enable pin (EN) goes high, the soft-start function generates an internal voltage ramp. This causes the start-up current to slowly rise preventing output voltage overshoot and high inrush currents. The soft-start duration is typical 1 ms (see Figure 13). When the soft-start function is completed, the error amplifier is connected directly to the internal voltage reference.

enable

Logic low on EN forces the TPS6200x into shutdown. In shutdown, the power switch, drivers, voltage reference, oscillator, and all other functions are turned off. The supply current is reduced to less than 1 μ A in the shutdown mode.

undervoltage lockout

An undervoltage lockout circuit provides the save operation of the device and it prevents the converter from turning on when the voltage on V_{IN} is less than 1.6 V typical.

power good comparator

The power good (PG) comparator has an open drain output capable of sinking typically 10 μ A. The PG is only active when the device is enabled (EN = high). When the device is disabled (EN = low), the PG pin is high impedance.

The PG output is only valid after a 100 μ s delay after the device is enabled and the supply voltage is greater than 1.2 V. This is only important in cases where the pullup resistor of the PG pin is connected to an external voltage source, which might cause an initial spike (false high signal) within the first 100 μ s after the input voltage exceeds 1.2 V. This initial spike can be filtered with a small R-C filter to avoid false power good signals during start-up.

If the PG pin is connected to the output of the TPS62000 with a pullup resistor, no initial spike (false high signal) occurs and no precautions have to be taken during start-up.

The PG pin becomes active high when the output voltage exceeds typically 94.5% of its nominal value. Leave the PG pin unconnected when not used.

no load operation

In case the converter operates in the forced PWM mode and there is no load connected to the output, the converter regulates the output voltage by allowing the inductor current to reverse for a short period of time.



**TPS62000-Q1, TPS62001-Q1, TPS62002-Q1, TPS62003-Q1
TPS62004-Q1, TPS62005-Q1, TPS62006-Q1, TPS62007-Q1, TPS62008-Q1
HIGH-EFFICIENCY STEP-DOWN LOW POWER DC-DC CONVERTER**

SGLS243A – APRIL 2004 – REVISED JUNE 2008

absolute maximum ratings over operating free-air temperature (unless otherwise noted)†

Supply voltages on pin V_{IN} and FC (see Note 1)	-0.3 V to 6 V
Voltages on pins EN, ILIM, SYNC, PG, FB, L (see Note 1)	-0.3 V to $V_{IN} + 0.3$ V
Peak switch current	1.6 A
Continuous power dissipation	See Dissipation Rating Table
Operating junction temperature range, T_J	-40°C to 150°C
Storage temperature range, T_{Stg}	-65°C to 150°C
Lead temperature (soldering, 10 sec)	260°C

† Stresses beyond those listed under “absolute maximum ratings” may cause permanent damage to the device. These are stress ratings only, and functional operation of the device at these or any other conditions beyond those indicated under “recommended operating conditions” is not implied. Exposure to absolute-maximum-rated conditions for extended periods may affect device reliability.

NOTE 1: All voltage values are with respect to network ground terminal.

DISSIPATION RATING TABLE

PACKAGE	$T_A \leq 25^\circ\text{C}$	DERATING FACTOR	$T_A = 70^\circ\text{C}$	$T_A = 85^\circ\text{C}$
	POWER RATING	ABOVE $T_A = 25^\circ\text{C}$	POWER RATING	POWER RATING
10 pin MSOP	555 mW	5.56 mW/°C	305 mW	221 mW

NOTE: The thermal resistance junction to ambient of the 10-pin MSOP is 180°C/W. The device will not run into thermal limitations, provided it is operated within the specified range.

recommended operating conditions

	MIN	TYP	MAX	UNIT
Supply voltage, V_I	2		5.5	V
Output voltage range for adjustable output voltage version, V_O	0.8		V_I	V
Output current for 3-cell operation, I_O ($V_I \geq 2.5$ V; $L = 10$ μ H, $f = 750$ kHz)			600	mA
Output current for 2-cell operation, I_O ($V_I \geq 2$ V; $L = 10$ μ H, $f = 750$ kHz)			200	mA
Inductor, L (see Note 2)		10		μ H
Input capacitor, C_i (see Note 2)	10			μ F
Output capacitor, C_O (see Note 2) $V_O \geq 1.8$ V)	10			μ F
Output capacitor, C_O (see Note 2) $V_O < 1.8$ V)	47			μ F
Operating junction temperature, T_J	-40		125	°C

NOTE 2: See the *Application Information* section for further information.

electrical characteristics over recommended operating free-air temperature range, $V_I = 3.6$ V, $V_O = 2.5$ V, $I_O = 300$ mA, EN = V_{IN} , ILIM = V_{IN} , $T_J = -40^\circ\text{C}$ to 125°C (unless otherwise noted)

supply current

PARAMETER	TEST CONDITIONS	MIN	TYP	MAX	UNIT
V_I Input voltage range	$I_O = 0$ mA to 600 mA	2.5		5.5	V
	$I_O = 0$ mA to 200 mA	2		5.5	
$I_{(Q)}$ Operating quiescent current	$I_O = 0$ mA, SYNC = GND (PFM-mode enabled)		50	75	μ A
$I_{(SD)}$ Shutdown current	EN = GND		0.1	1	μ A

enable

PARAMETER	TEST CONDITIONS	MIN	TYP	MAX	UNIT
V_{IH} EN high-level input voltage		1.3			V
V_{IL} EN low level input voltage				0.4	V
I_{lkg} EN input leakage current	EN = GND or V_{IN}		0.01	0.1	μ A
$V_{(UVLO)}$ Undervoltage lockout threshold		1.2	1.6	1.95	V



**TPS62000-Q1, TPS62001-Q1, TPS62002-Q1, TPS62003-Q1
 TPS62004-Q1, TPS62005-Q1, TPS62006-Q1, TPS62007-Q1, TPS62008-Q1
 HIGH-EFFICIENCY STEP-DOWN LOW POWER DC-DC CONVERTER**

SGLS243A – APRIL 2004 – REVISED JUNE 2008

electrical characteristics over recommended operating free-air temperature range, $V_I = 3.6\text{ V}$, $V_O = 2.5\text{ V}$, $I_O = 300\text{ mA}$, $EN = V_{IN}$, $ILIM = V_{IN}$, $T_J = -40^\circ\text{C}$ to 125°C (unless otherwise noted) (continued)

power switch and current limit

PARAMETER		TEST CONDITIONS	MIN	TYP	MAX	UNIT
$r_{DS(on)}$	P-channel MOSFET on-resistance	$V_I = V_{GS} = 3.6\text{ V}$, $I = 200\text{ mA}$	150	280	600	$m\Omega$
		$V_I = V_{GS} = 2\text{ V}$, $I = 200\text{ mA}$	480			
	P-channel leakage current	$V_{DS} = 5.5\text{ V}$	1			μA
	N-channel MOSFET on-resistance	$V_I = V_{GS} = 3.6\text{ V}$, $I_O = 200\text{ mA}$	150	280	600	$m\Omega$
		$V_I = V_{GS} = 2\text{ V}$, $I_O = 200\text{ mA}$	500			
N-channel leakage current	$V_{DS} = 5.5\text{ V}$	1			μA	
$I_{(LIM)}$	P-channel current limit	$2.5\text{ V} \leq V_I \leq 5.5\text{ V}$, $ILIM = V_{IN}$	800	1200	1600	mA
		$2\text{ V} \leq V_I \leq 5.5\text{ V}$, $ILIM = \text{GND}$	390	600	900	
V_{IH}	ILIM high-level input voltage		1.3			V
V_{IL}	ILIM low-level input voltage			0.4		V
I_{lkg}	ILIM input leakage current	$ILIM = \text{GND}$ or V_{IN}		0.01	0.1	μA

power good output (see Note 3)

PARAMETER		TEST CONDITIONS	MIN	TYP	MAX	UNIT
$V_{(PG)}$	Power good threshold	Feedback voltage falling	88% V_O	92% V_O	94% V_O	V
	Power good hysteresis		2.5% V_O			V
V_{OL}	PG output low voltage	$V_{(FB)} = 0.8 \times V_O$ nominal, $I_{(sink)} = 10\ \mu\text{A}$	0.3			V
I_{lkg}	PG output leakage current	$V_{(FB)} = V_O$ nominal	0.01		1	μA
Minimum supply voltage for valid power good signal			1.2			V

NOTE 3: Power good is not valid for the first 100 μs after EN goes high. Please refer to the application section for more information.

oscillator

PARAMETER		TEST CONDITIONS	MIN	TYP	MAX	UNIT
f_s	Oscillator frequency		500	750	1000	kHz
$f(\text{SYNC})$	Synchronization range	CMOS-logic clock signal on SYNC pin	500		1000	kHz
V_{IH}	SYNC high level input voltage		1.3			V
V_{IL}	SYNC low level input voltage				0.4	V
I_{lkg}	SYNC input leakage current	$\text{SYNC} = \text{GND}$ or V_{IN}	0.01		0.1	μA
Duty cycle of external clock signal			20%		60%	



**TPS62000-Q1, TPS62001-Q1, TPS62002-Q1, TPS62003-Q1
TPS62004-Q1, TPS62005-Q1, TPS62006-Q1, TPS62007-Q1, TPS62008-Q1
HIGH-EFFICIENCY STEP-DOWN LOW POWER DC-DC CONVERTER**

SGLS243A – APRIL 2004 – REVISED JUNE 2008

electrical characteristics over recommended operating free-air temperature range, $V_I = 3.6\text{ V}$, $V_O = 2.5\text{ V}$, $I_O = 300\text{ mA}$, $EN = V_{IN}$, $ILIM = V_{IN}$, $T_J = -40^\circ\text{C}$ to 125°C (unless otherwise noted) (continued)

output

PARAMETER		TEST CONDITIONS	MIN	TYP	MAX	UNIT	
V_O	Adjustable output voltage range	TPS62000	0.8		5.5	V	
V_{ref}	Reference voltage	TPS6200x		0.45		V	
V_O	Fixed output voltage (see Note 4)	TPS62000 adjustable	$V_I = 2.5\text{ V to }5.5\text{ V}; 0\text{ mA} \leq I_O \leq 600\text{ mA}$	-4%		4%	V
			$10\text{ mA} < I_O \leq 600\text{ mA}$	-4%		3%	
		TPS62001 0.9 V	$V_I = 2.5\text{ V to }5.5\text{ V}; 0\text{ mA} \leq I_O \leq 600\text{ mA}$	-4%		4%	
			$10\text{ mA} < I_O \leq 600\text{ mA}$	-4%		3%	
		TPS62002 1 V	$V_I = 2.5\text{ V to }5.5\text{ V}; 0\text{ mA} \leq I_O \leq 600\text{ mA}$	-4%		4%	
			$10\text{ mA} < I_O \leq 600\text{ mA}$	-4%		3%	
		TPS62003 1.2 V	$V_I = 2.5\text{ V to }5.5\text{ V}; 0\text{ mA} \leq I_O \leq 600\text{ mA}$	-4%		4%	
			$10\text{ mA} < I_O \leq 600\text{ mA}$	-4%		3%	
		TPS62004 1.5 V	$V_I = 2.5\text{ V to }5.5\text{ V}; 0\text{ mA} \leq I_O \leq 600\text{ mA}$	-4%		4%	
			$10\text{ mA} < I_O \leq 600\text{ mA}$	-4%		3%	
		TPS62005 1.8 V	$V_I = 2.5\text{ V to }5.5\text{ V}; 0\text{ mA} \leq I_O \leq 600\text{ mA}$	-4%		4%	
			$10\text{ mA} < I_O \leq 600\text{ mA}$	-4%		3%	
		TPS62008 1.9 V	$V_I = 2.5\text{ V to }5.5\text{ V}; 0\text{ mA} \leq I_O \leq 600\text{ mA}$	-4%		4%	
			$10\text{ mA} < I_O \leq 600\text{ mA}$	-4%		3%	
		TPS62006 2.5 V	$V_I = 2.7\text{ V to }5.5\text{ V}; 0\text{ mA} \leq I_O \leq 600\text{ mA}$	-4%		4%	
			$10\text{ mA} < I_O \leq 600\text{ mA}$	-4%		3%	
TPS62007 3.3 V	$V_I = 3.6\text{ V to }5.5\text{ V}; 0\text{ mA} \leq I_O \leq 600\text{ mA}$	-4%		4%			
	$10\text{ mA} < I_O \leq 600\text{ mA}$	-4%		3%			
Line regulation		$V_I = V_O + 0.5\text{ V (min. }2\text{ V) to }5.5\text{ V}$, $I_O = 10\text{ mA}$		0.05		%/V	
Load regulation		$V_I = 5.5\text{ V}; I_O = 10\text{ mA to }600\text{ mA}$		0.6%			
η	Efficiency	$V_I = 5\text{ V}; V_O = 3.3\text{ V}; I_O = 300\text{ mA}$		95%			
		$V_I = 3.6\text{ V}; V_O = 2.5\text{ V}; I_O = 200\text{ mA}$					
Start-up time		$I_O = 0\text{ mA}$, time from active EN to V_O	0.4		2	ms	

NOTE 4: The output voltage accuracy includes line and load regulation over the full temperature range, $T_J = -40^\circ\text{C}$ to 125°C .

**TPS62000-Q1, TPS62001-Q1, TPS62002-Q1, TPS62003-Q1
 TPS62004-Q1, TPS62005-Q1, TPS62006-Q1, TPS62007-Q1, TPS62008-Q1
 HIGH-EFFICIENCY STEP-DOWN LOW POWER DC-DC CONVERTER**

SGLS243A – APRIL 2004 – REVISED JUNE 2008

TYPICAL CHARACTERISTICS

Table of Graphs

			FIGURE
η	Efficiency	vs Load current	3, 4, 5
$V_{(drop)}$	Dropout voltage	vs Load current	6
I_Q	Operating quiescent current	vs Input voltage (power save mode)	7
		vs Input voltage (forced PWM)	8
f_{osc}	Oscillator frequency	vs Free-air temperature	9
	Load transient response		10
	Line transient response		11
	Power save mode operation		12
	Start-up	vs Time	13
V_O	Output voltage	vs Load current	14

**EFFICIENCY
 vs
 LOAD CURRENT**

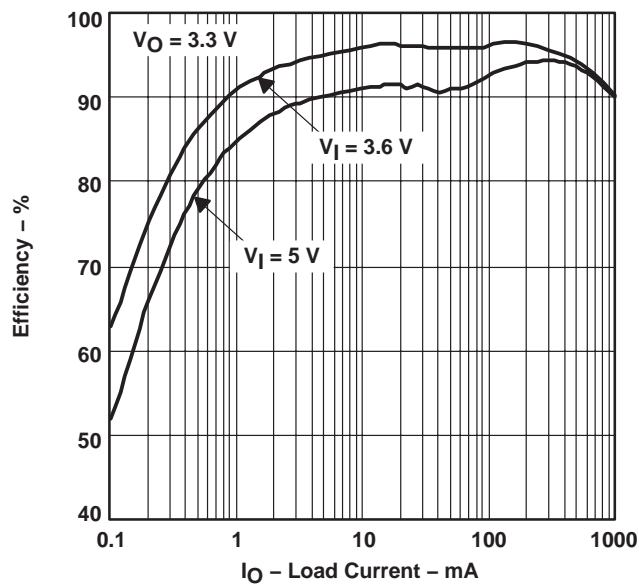

Figure 3

**EFFICIENCY
 vs
 LOAD CURRENT**

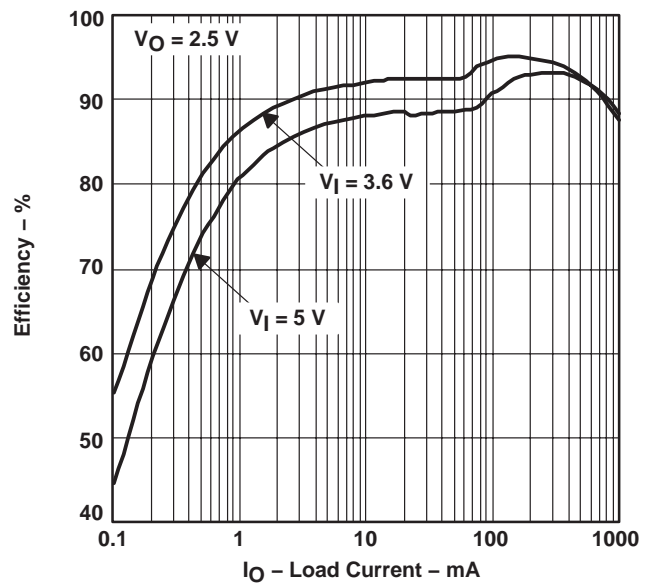

Figure 4

TPS62000-Q1, TPS62001-Q1, TPS62002-Q1, TPS62003-Q1
 TPS62004-Q1, TPS62005-Q1, TPS62006-Q1, TPS62007-Q1, TPS62008-Q1
 HIGH-EFFICIENCY STEP-DOWN LOW POWER DC-DC CONVERTER

SGLS243A – APRIL 2004 – REVISED JUNE 2008

TYPICAL CHARACTERISTICS

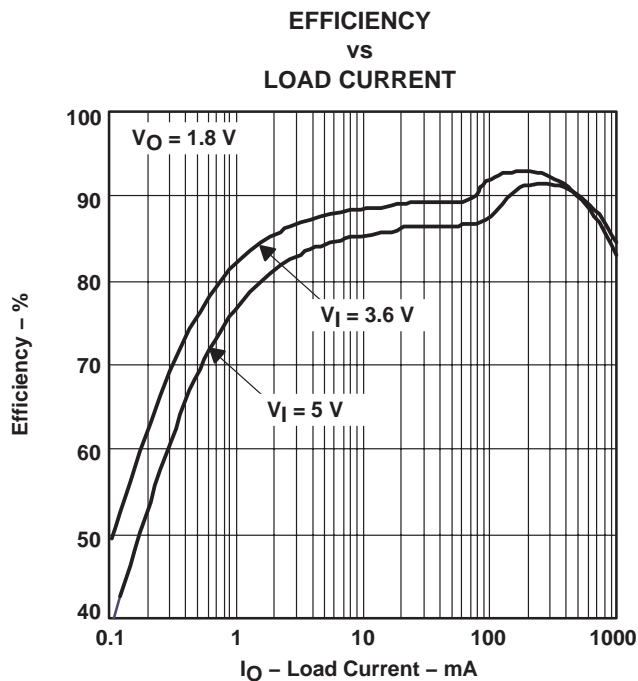

Figure 5

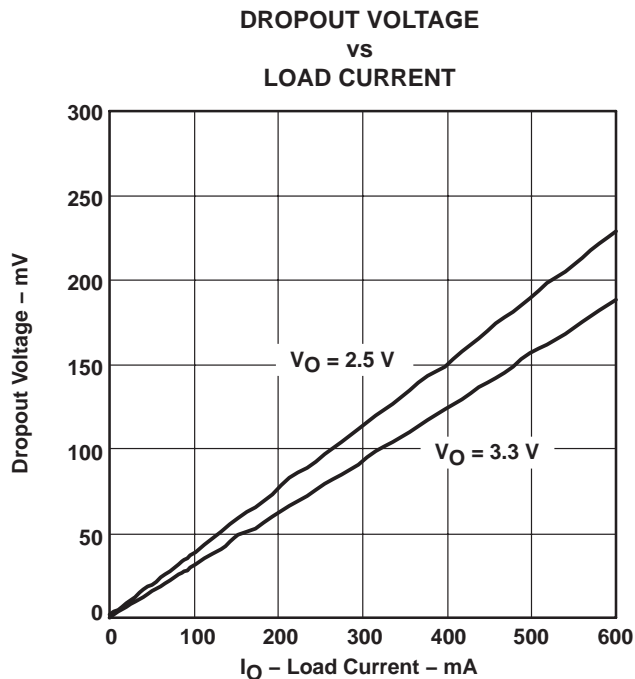

Figure 6

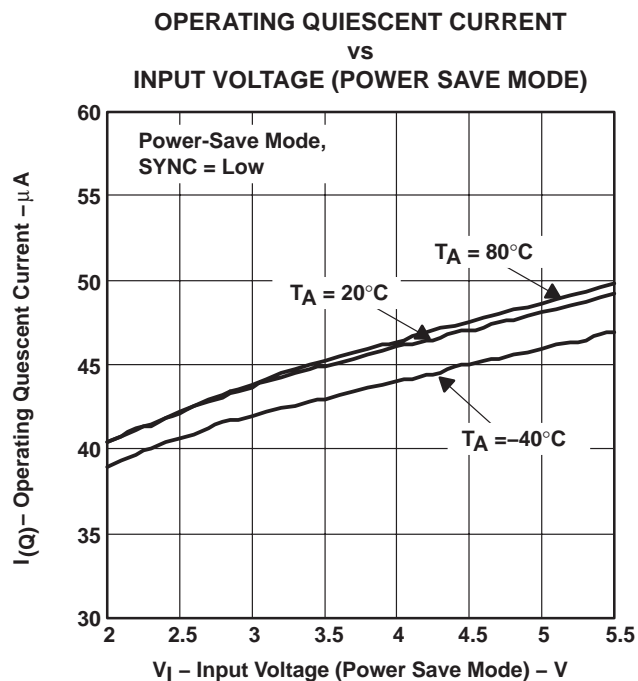

Figure 7

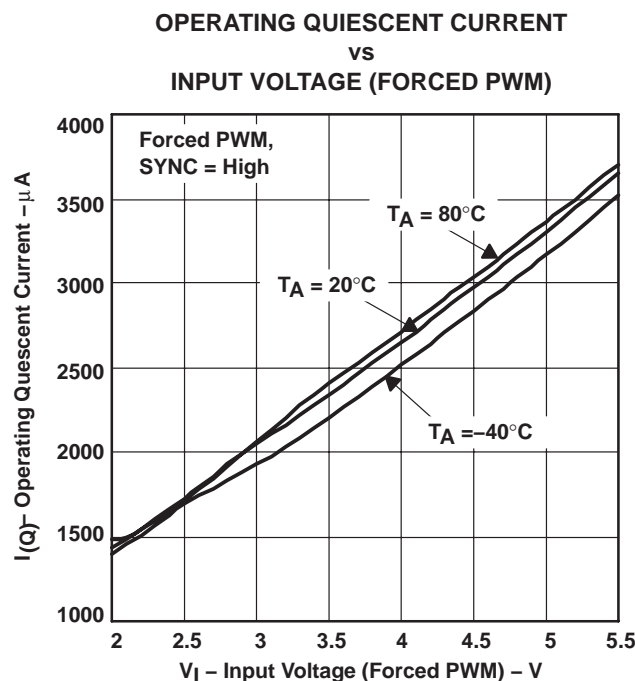

Figure 8

**TPS62000-Q1, TPS62001-Q1, TPS62002-Q1, TPS62003-Q1
 TPS62004-Q1, TPS62005-Q1, TPS62006-Q1, TPS62007-Q1, TPS62008-Q1
 HIGH-EFFICIENCY STEP-DOWN LOW POWER DC-DC CONVERTER**

SGLS243A – APRIL 2004 – REVISED JUNE 2008

TYPICAL CHARACTERISTICS

**OSCILLATOR FREQUENCY
 vs
 FREE-AIR TEMPERATURE**

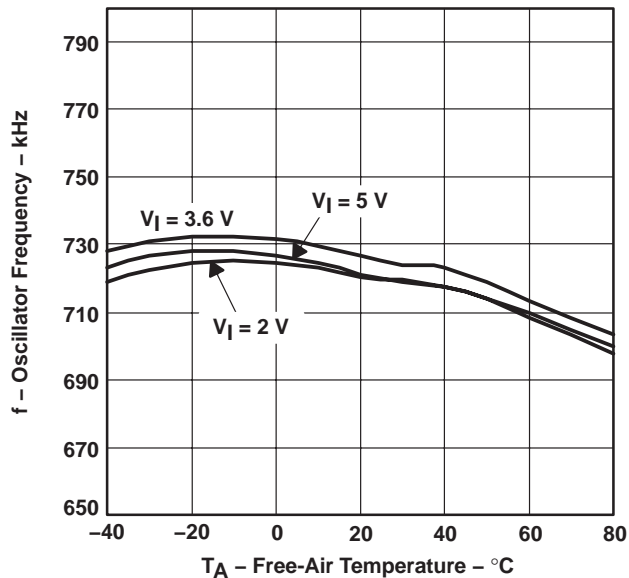

Figure 9

LOAD TRANSIENT RESPONSE

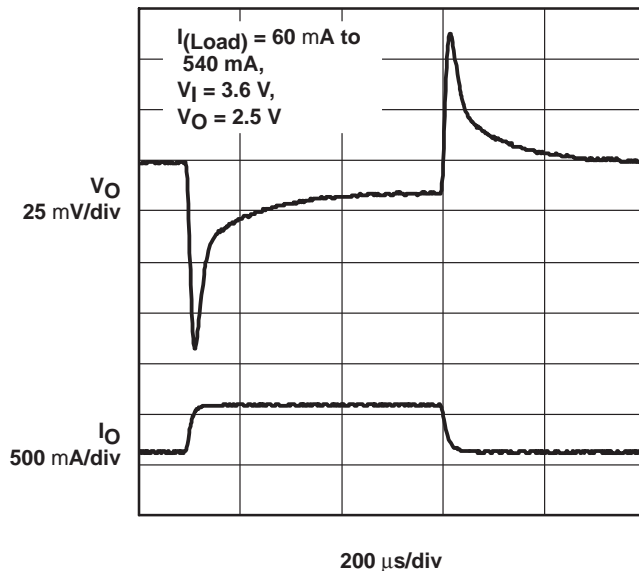

Figure 10

LINE TRANSIENT RESPONSE

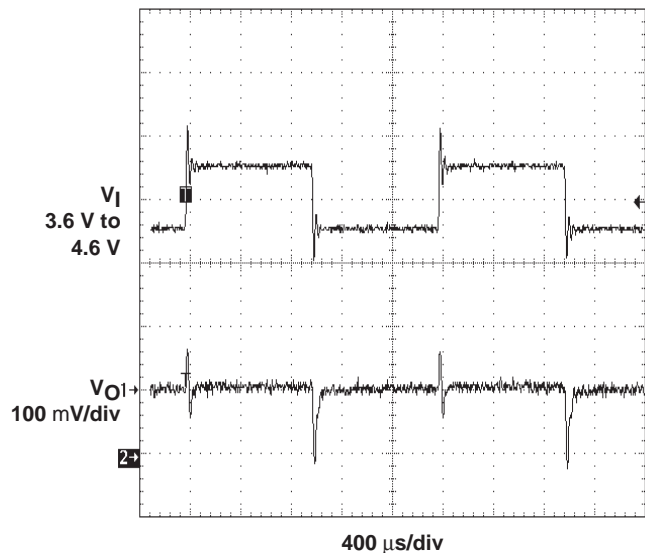

Figure 11

POWER SAVE MODE OPERATION

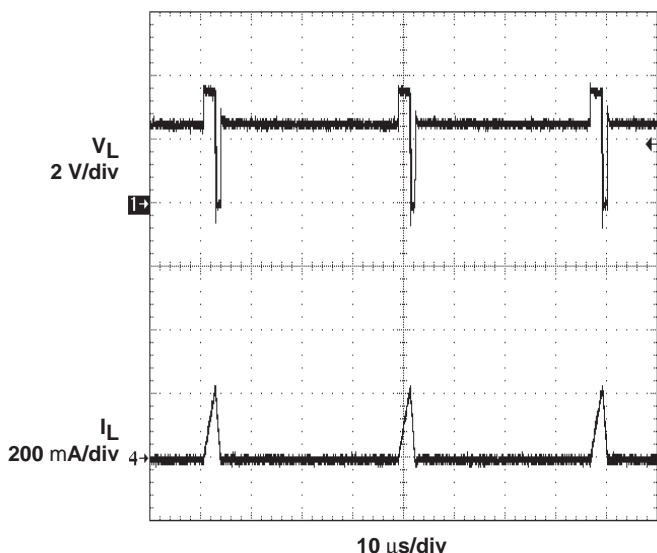

Figure 12

TYPICAL CHARACTERISTICS

START-UP
 vs
 TIME

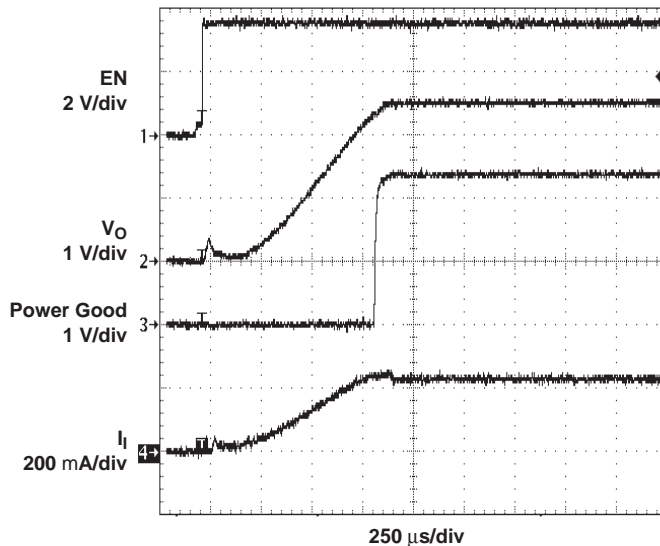

Figure 13

OUTPUT VOLTAGE
 vs
 LOAD CURRENT

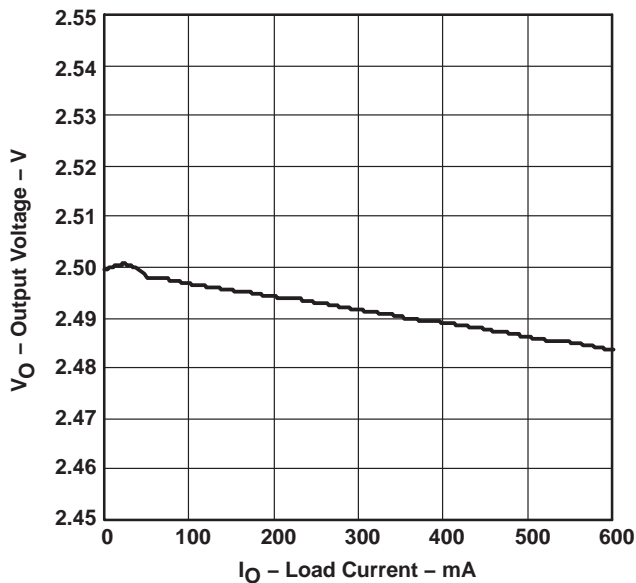

Figure 14

**TPS62000-Q1, TPS62001-Q1, TPS62002-Q1, TPS62003-Q1
 TPS62004-Q1, TPS62005-Q1, TPS62006-Q1, TPS62007-Q1, TPS62008-Q1
 HIGH-EFFICIENCY STEP-DOWN LOW POWER DC-DC CONVERTER**

SGLS243A – APRIL 2004 – REVISED JUNE 2008

APPLICATION INFORMATION

adjustable output voltage version

When the adjustable output voltage version (TPS62000) is used, the output voltage is set by the external resistor divider (see Figure 15).

The output voltage is calculated as:

$$V_O = 0.45 \text{ V} \times \left(1 + \frac{R1}{R2} \right)$$

With $R1 + R2 \leq 1 \text{ M}\Omega$

$R1 + R2$ should not be greater than $1 \text{ M}\Omega$ because of stability reasons.

For stability reasons, a small bypass capacitor (C_{ff}) is required in parallel to the upper feedback resistor, see Figure 15. The bypass capacitor value can be calculated as:

$$C_{(ff)} = \frac{1}{2\pi \times 30000 \times R1} \text{ for } C_o < 47 \mu\text{F}$$

$$C_{(ff)} = \frac{1}{2\pi \times 5000 \times R1} \text{ for } C_o \geq 47 \mu\text{F}$$

$R1$ is the upper resistor of the voltage divider. For $C_{(ff)}$, choose a value which comes closest to the computed result.

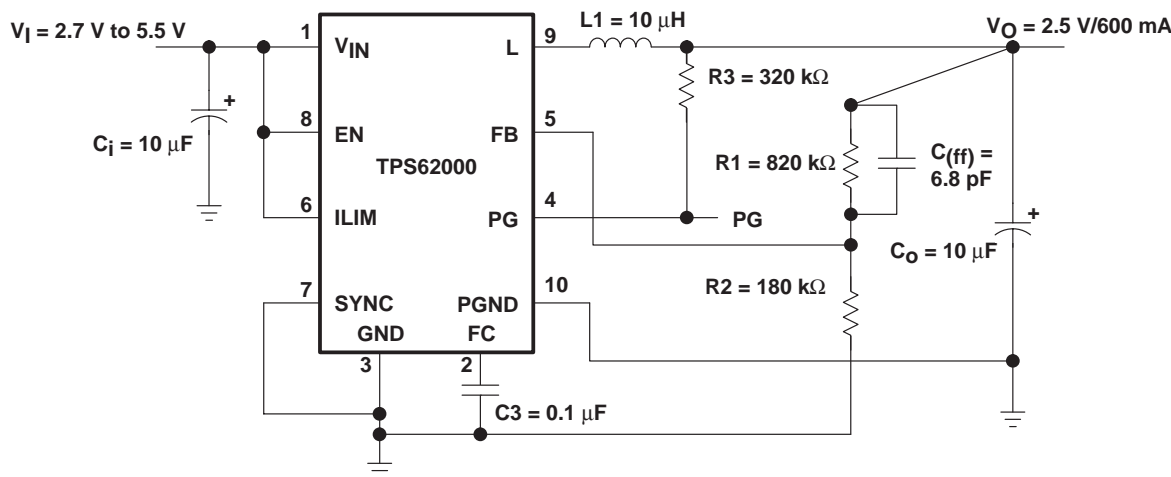

Figure 15. Typical Application Circuit for Adjustable Output Voltage Option

inductor selection

A $10 \mu\text{H}$ minimum output inductor is used with the TPS6200x. Values larger than $22 \mu\text{H}$ or smaller than $10 \mu\text{H}$ may cause stability problems because of the internal compensation of the regulator.

For output voltages greater than 1.8 V , a $22\text{-}\mu\text{H}$ inductance might be used in order to improve the efficiency of the converter.

After choosing the inductor value of typically $10 \mu\text{H}$, two additional inductor parameters should be considered: first the current rating of the inductor and second the dc resistance.

The dc resistance of the inductance influences directly the efficiency of the converter. Therefore, an inductor with the lowest dc resistance should be selected for the highest efficiency.



APPLICATION INFORMATION

inductor selection (continued)

In order to avoid saturation of the inductor, the inductor should be rated at least for the maximum output current plus the inductor ripple current which is calculated as:

$$\Delta I_L = V_O \times \frac{1 - \frac{V_O}{V_I}}{L \times f} \quad I_{L(\max)} = I_{O(\max)} + \frac{\Delta I_L}{2}$$

Where:

f = Switching frequency (750 kHz typical)

L = Inductor value

ΔI_L = Peak-to-peak inductor ripple current

$I_{L(\max)}$ = Maximum inductor current

The highest inductor current occurs at maximum V_I .

A more conservative approach is to select the inductor current rating just for the maximum switch current of the TPS6200x which is 1.6 A with $ILIM = V_{IN}$ and 900 mA with $ILIM = GND$. See Table 1 for recommended inductors.

Table 1. Tested Inductors

OUTPUT CURRENT	INDUCTOR VALUE	COMPONENT SUPPLIER	COMMENTS
0 mA to 600 mA	10 μ H	Coilcraft DO3316P-103 Coilcraft DT3316P-103 Sumida CDR63B-100 Sumida CDRH5D28-100	High efficiency
		Coilcraft DO1608C-103 Sumida CDRH4D28-100	Smallest solution
0 mA to 300 mA	10 μ H	Coilcraft DS1608C-103	High efficiency
		muRata LQH4C100K04	Smallest solution

output capacitor selection

For best performance, a low ESR output capacitor is needed. At output voltages greater than 1.8 V, ceramic output capacitors can be used to show the best performance. Output voltages below 1.8 V require a larger output capacitor and ESR value to improve the performance and stability of the converter.

Table 2. Capacitor Selection

OUTPUT VOLTAGE RANGE	OUTPUT CAPACITOR	OUTPUT CAPACITOR ESR
$1.8 \text{ V} \leq V_I \leq 5.5 \text{ V}$	$C_O \geq 10 \mu\text{F}$	$\text{ESR} \leq 120 \text{ m}\Omega$
$0.8 \text{ V} \leq V_I < 1.8 \text{ V}$	$C_O \geq 47 \mu\text{F}$	$\text{ESR} > 50 \text{ m}\Omega$

See Table 3 for recommended capacitors.

**TPS62000-Q1, TPS62001-Q1, TPS62002-Q1, TPS62003-Q1
 TPS62004-Q1, TPS62005-Q1, TPS62006-Q1, TPS62007-Q1, TPS62008-Q1
 HIGH-EFFICIENCY STEP-DOWN LOW POWER DC-DC CONVERTER**

SGLS243A – APRIL 2004 – REVISED JUNE 2008

APPLICATION INFORMATION

output capacitor selection (continued)

If an output capacitor is selected with an ESR value $\leq 120 \text{ m}\Omega$, its RMS ripple current rating always meets the application requirements. The RMS ripple current is calculated as:

$$I_{\text{RMS}(C_O)} = V_O \times \frac{1 - \frac{V_O}{V_I}}{L \times f} \times \frac{1}{2 \times \sqrt{3}}$$

The overall output ripple voltage is the sum of the voltage spike caused by the output capacitor ESR plus the voltage ripple caused by charge and discharging the output capacitor:

$$\Delta V_O = V_O \times \frac{1 - \frac{V_O}{V_I}}{L \times f} \times \left(\frac{1}{8 \times C_O \times f} + \text{ESR} \right)$$

Where the highest output voltage ripple occurs at the highest input voltage V_I .

Table 3. Tested Capacitors

CAPACITOR VALUE	ESR/mΩ	COMPONENT SUPPLIER	COMMENTS
10 μF	50	Taiyo Yuden JMK316BJ106KL	Ceramic
47 μF	100	Sanyo 6TPA47M	POSCAP
68 μF	100	Sprague 594D686X0010C2T	Tantalum

input capacitor selection

Because of the nature of the buck converter having a pulsating input current, a low ESR input capacitor is required for best input voltage filtering and minimizing the interference with other circuits caused by high input voltage spikes.

The input capacitor should have a minimum value of 10 μF and can be increased without any limit for better input voltage filtering.

The input capacitor should be rated for the maximum input ripple current calculated as:

$$I_{\text{RMS}} = I_{O(\text{max})} \times \sqrt{\frac{V_O}{V_I} \times \left(1 - \frac{V_O}{V_I} \right)}$$

The worst case RMS ripple current occurs at $D = 0.5$ and is calculated as: $I_{\text{RMS}} = \frac{I_O}{2}$.

Ceramic capacitors show a good performance because of their low ESR value and they are less sensitive against voltage transients compared to tantalum capacitors.

Place the input capacitor as close as possible to the input pin of the IC for best performance.



**TPS62000-Q1, TPS62001-Q1, TPS62002-Q1, TPS62003-Q1
TPS62004-Q1, TPS62005-Q1, TPS62006-Q1, TPS62007-Q1, TPS62008-Q1
HIGH-EFFICIENCY STEP-DOWN LOW POWER DC-DC CONVERTER**

SGLS243A – APRIL 2004 – REVISED JUNE 2008

APPLICATION INFORMATION

layout considerations

As for all switching power supplies, the layout is an important step in the design, especially at high peak currents and switching frequencies. If the layout is not carefully done, the regulator might show stability problems as well as EMI problems.

Therefore, use wide and short traces for the main current paths as indicated in bold in Figure 16. The input capacitor should be placed as close as possible to the IC pins, as well as the inductor and output capacitor. Place the bypass capacitor, C3, as close as possible to the FC pin. The analog ground, GND, and the power ground, PGND, need to be separated. Use a common-ground node, as shown in Figure 16, to minimize the effects of ground noise.

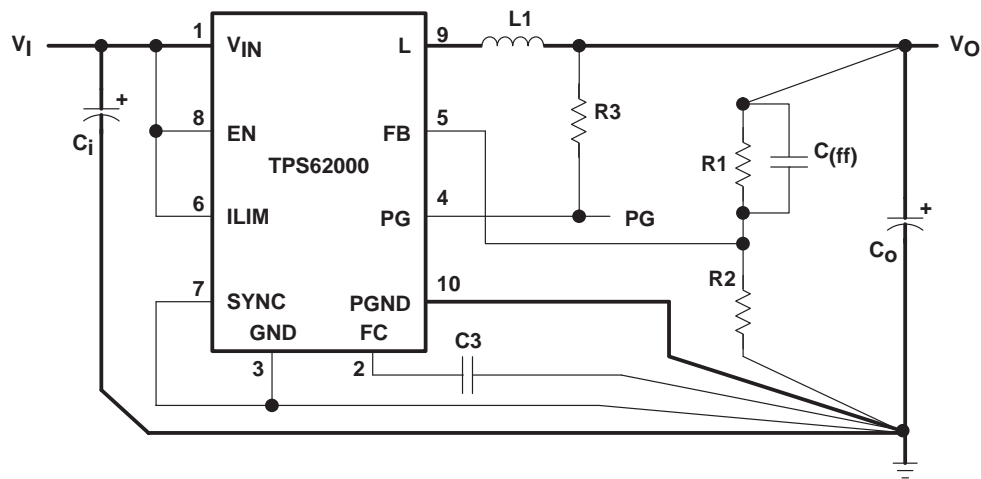

Figure 16. Layout Diagram

typical application

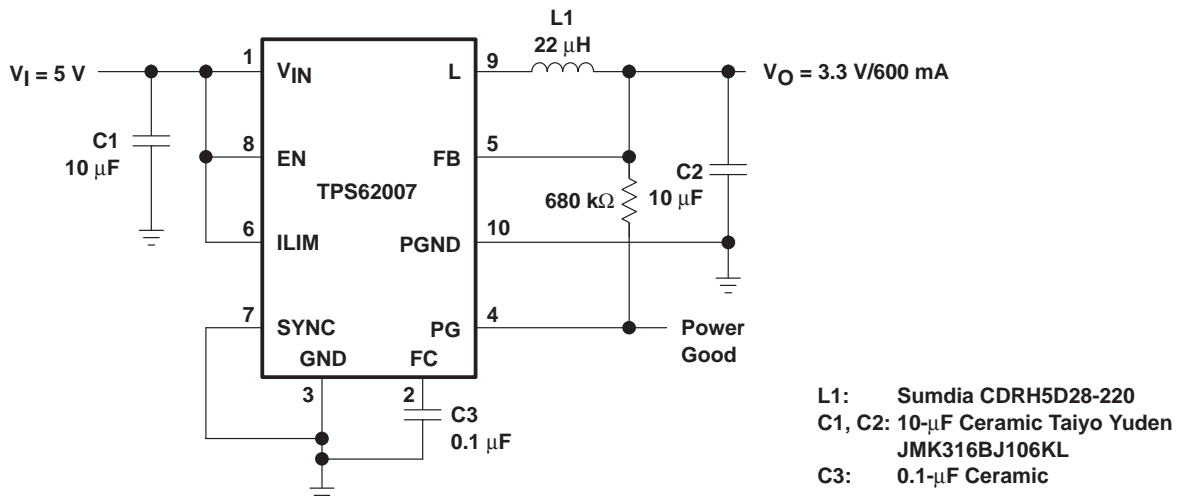

Figure 17. Standard 5 V to 3.3 V/600 mA Conversion – High Efficiency

**TPS62000-Q1, TPS62001-Q1, TPS62002-Q1, TPS62003-Q1
 TPS62004-Q1, TPS62005-Q1, TPS62006-Q1, TPS62007-Q1, TPS62008-Q1
 HIGH-EFFICIENCY STEP-DOWN LOW POWER DC-DC CONVERTER**

SGLS243A – APRIL 2004 – REVISED JUNE 2008

APPLICATION INFORMATION

typical application (continued)

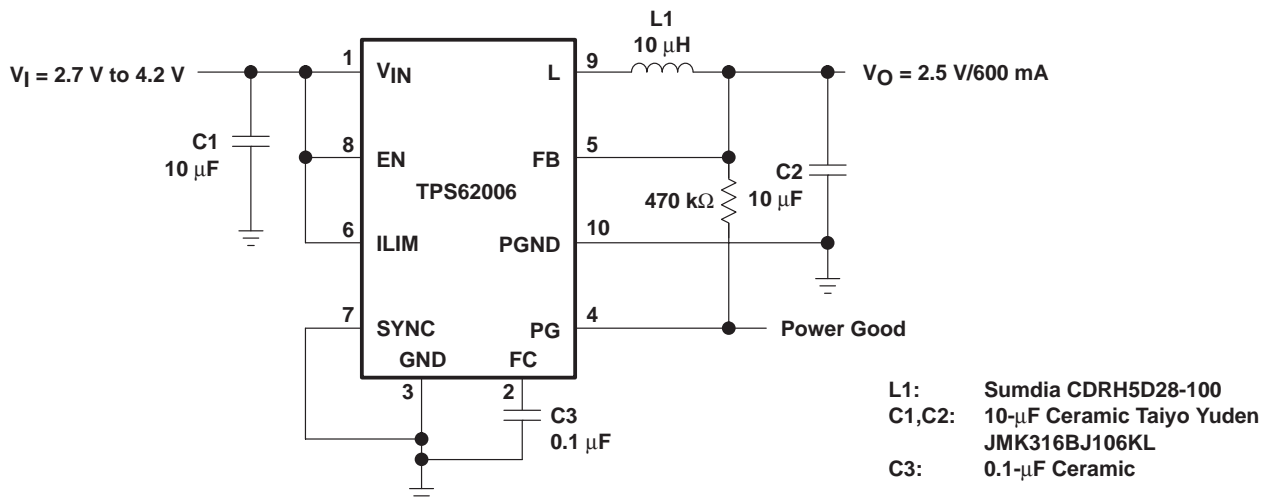
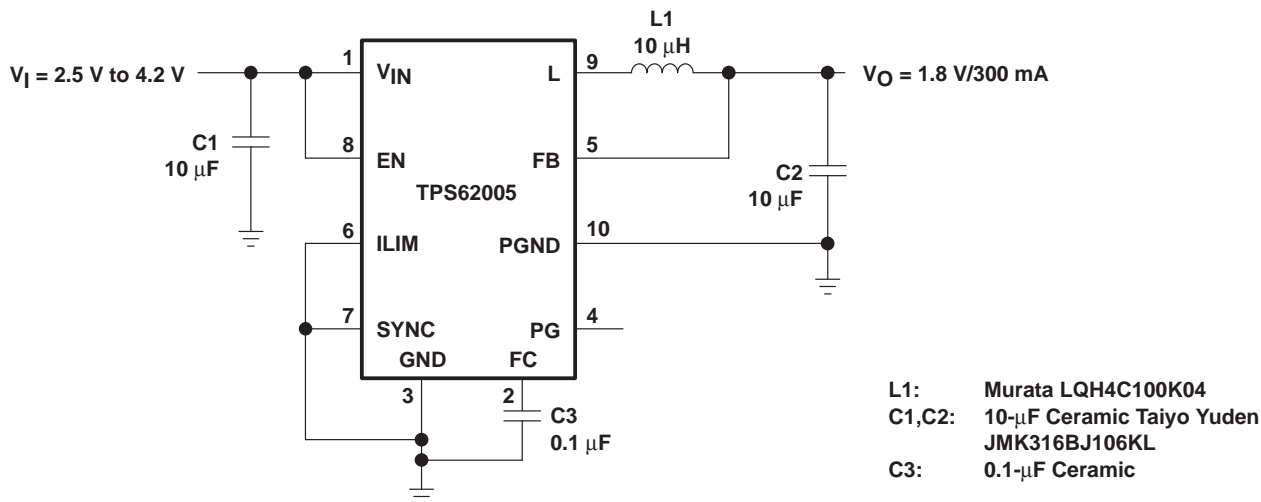

Figure 18. Single Li-on to 2.5 V/600 mA Using Ceramic Capacitors Only



NOTE: For low noise operation, connect SYNC to V_{IN}.

Figure 19. Single Li-on to 1.8 V/300 mA – Smallest Solution Size

**TPS62000-Q1, TPS62001-Q1, TPS62002-Q1, TPS62003-Q1
TPS62004-Q1, TPS62005-Q1, TPS62006-Q1, TPS62007-Q1, TPS62008-Q1
HIGH-EFFICIENCY STEP-DOWN LOW POWER DC-DC CONVERTER**

SGLS243A – APRIL 2004 – REVISED JUNE 2008

APPLICATION INFORMATION

typical application (continued)

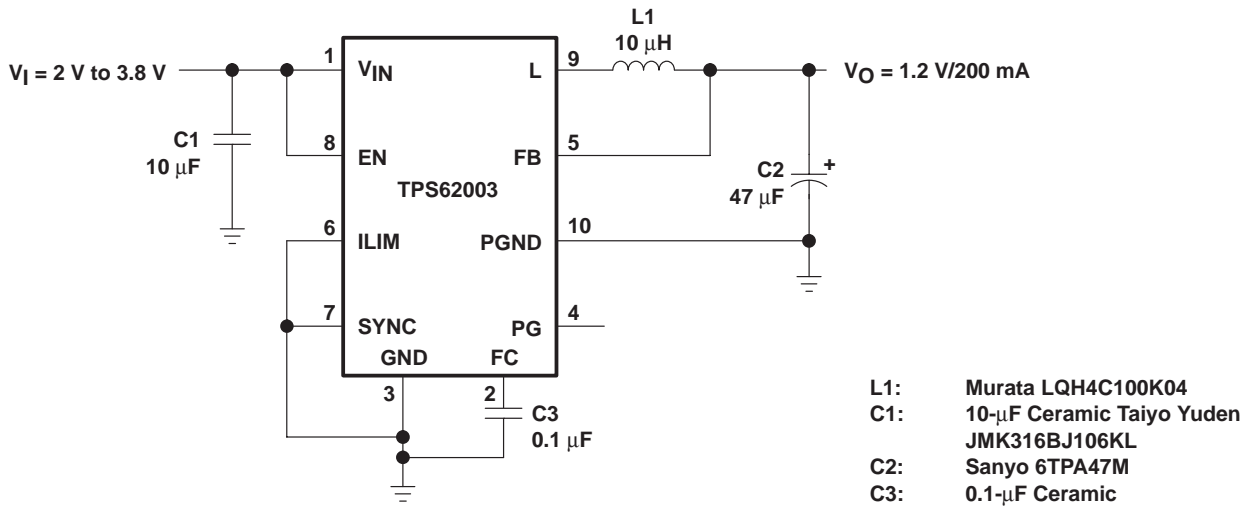
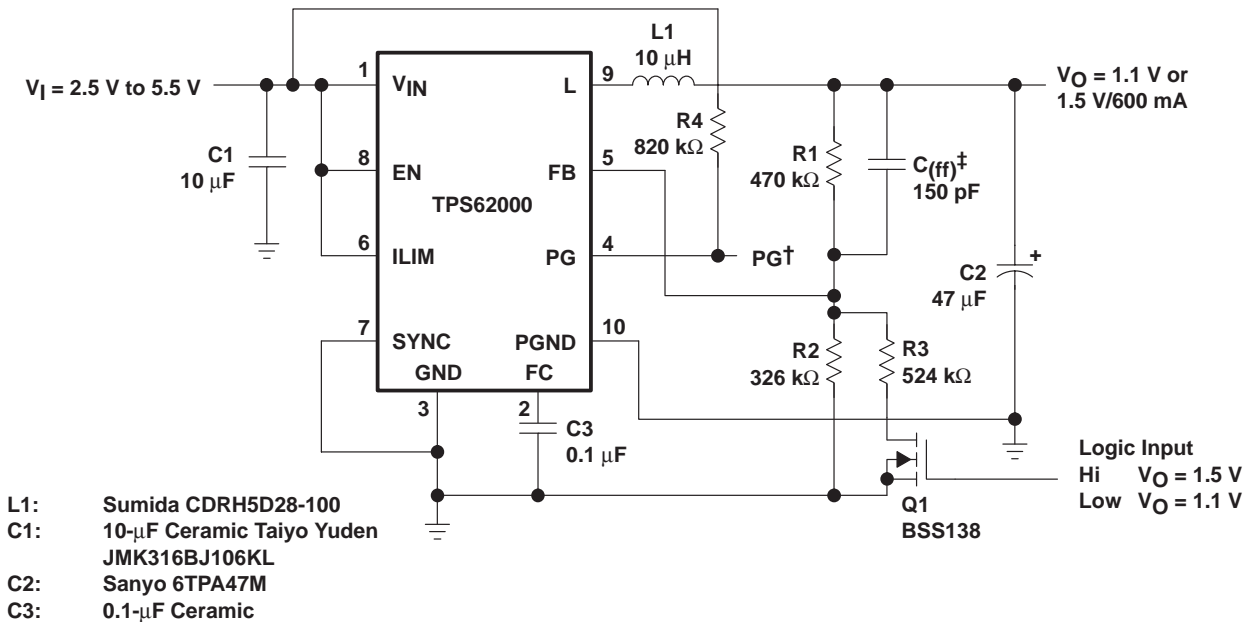

Figure 20. Dual Cell NiMH or NiCd to 1.2 V/200 mA – Smallest Solution Size



† Use a small R-C filter to filter wrong reset signals during output voltage transitions.

‡ A large value is used for $C_{(ff)}$ to compensate for the parasitic capacitance introduced into the regulation loop by Q1.

Figure 21. Dynamic Output Voltage Programming As Used in Low Power DSP Applications

PACKAGING INFORMATION

Orderable Device	Status (1)	Package Type	Package Drawing	Pins	Package Qty	Eco Plan (2)	Lead/Ball Finish (6)	MSL Peak Temp (3)	Op Temp (°C)	Device Marking (4/5)	Samples
TPS62000QDGSRQ1	ACTIVE	VSSOP	DGS	10	2500	Green (RoHS & no Sb/Br)	CU NIPDAU CU NIPDAUAG	Level-1-260C-UNLIM	-40 to 125	AOQ	Samples
TPS62004QDGSRQ1	ACTIVE	VSSOP	DGS	10	2500	Green (RoHS & no Sb/Br)	CU NIPDAU CU NIPDAUAG	Level-1-260C-UNLIM	-40 to 125	AOR	Samples
TPS62005QDGSRQ1	ACTIVE	VSSOP	DGS	10	2500	Green (RoHS & no Sb/Br)	CU NIPDAU CU NIPDAUAG	Level-1-260C-UNLIM	-40 to 125	ALY	Samples
TPS62007QDGSRQ1	ACTIVE	VSSOP	DGS	10	2500	Green (RoHS & no Sb/Br)	CU NIPDAU CU NIPDAUAG	Level-1-260C-UNLIM	-40 to 125	AOT	Samples

(1) The marketing status values are defined as follows:

ACTIVE: Product device recommended for new designs.

LIFEBUY: TI has announced that the device will be discontinued, and a lifetime-buy period is in effect.

NRND: Not recommended for new designs. Device is in production to support existing customers, but TI does not recommend using this part in a new design.

PREVIEW: Device has been announced but is not in production. Samples may or may not be available.

OBSELETE: TI has discontinued the production of the device.

(2) Eco Plan - The planned eco-friendly classification: Pb-Free (RoHS), Pb-Free (RoHS Exempt), or Green (RoHS & no Sb/Br) - please check <http://www.ti.com/productcontent> for the latest availability information and additional product content details.

TBD: The Pb-Free/Green conversion plan has not been defined.

Pb-Free (RoHS): TI's terms "Lead-Free" or "Pb-Free" mean semiconductor products that are compatible with the current RoHS requirements for all 6 substances, including the requirement that lead not exceed 0.1% by weight in homogeneous materials. Where designed to be soldered at high temperatures, TI Pb-Free products are suitable for use in specified lead-free processes.

Pb-Free (RoHS Exempt): This component has a RoHS exemption for either 1) lead-based flip-chip solder bumps used between the die and package, or 2) lead-based die adhesive used between the die and leadframe. The component is otherwise considered Pb-Free (RoHS compatible) as defined above.

Green (RoHS & no Sb/Br): TI defines "Green" to mean Pb-Free (RoHS compatible), and free of Bromine (Br) and Antimony (Sb) based flame retardants (Br or Sb do not exceed 0.1% by weight in homogeneous material)

(3) MSL, Peak Temp. - The Moisture Sensitivity Level rating according to the JEDEC industry standard classifications, and peak solder temperature.

(4) There may be additional marking, which relates to the logo, the lot trace code information, or the environmental category on the device.

(5) Multiple Device Markings will be inside parentheses. Only one Device Marking contained in parentheses and separated by a "~" will appear on a device. If a line is indented then it is a continuation of the previous line and the two combined represent the entire Device Marking for that device.

(6) Lead/Ball Finish - Orderable Devices may have multiple material finish options. Finish options are separated by a vertical ruled line. Lead/Ball Finish values may wrap to two lines if the finish value exceeds the maximum column width.

Important Information and Disclaimer: The information provided on this page represents TI's knowledge and belief as of the date that it is provided. TI bases its knowledge and belief on information provided by third parties, and makes no representation or warranty as to the accuracy of such information. Efforts are underway to better integrate information from third parties. TI has taken and continues to take reasonable steps to provide representative and accurate information but may not have conducted destructive testing or chemical analysis on incoming materials and chemicals. TI and TI suppliers consider certain information to be proprietary, and thus CAS numbers and other limited information may not be available for release.

In no event shall TI's liability arising out of such information exceed the total purchase price of the TI part(s) at issue in this document sold by TI to Customer on an annual basis.

OTHER QUALIFIED VERSIONS OF TPS62000-Q1, TPS62004-Q1, TPS62005-Q1, TPS62007-Q1 :

- Catalog: [TPS62000](#), [TPS62004](#), [TPS62005](#), [TPS62007](#)

NOTE: Qualified Version Definitions:

- Catalog - TI's standard catalog product

TAPE AND REEL INFORMATION

QUADRANT ASSIGNMENTS FOR PIN 1 ORIENTATION IN TAPE

*All dimensions are nominal

Device	Package Type	Package Drawing	Pins	SPQ	Reel Diameter (mm)	Reel Width W1 (mm)	A0 (mm)	B0 (mm)	K0 (mm)	P1 (mm)	W (mm)	Pin1 Quadrant
TPS62000QDGSRQ1	VSSOP	DGS	10	2500	330.0	12.4	5.3	3.4	1.4	8.0	12.0	Q1
TPS62004QDGSRQ1	VSSOP	DGS	10	2500	330.0	12.4	5.3	3.4	1.4	8.0	12.0	Q1
TPS62005QDGSRQ1	VSSOP	DGS	10	2500	330.0	12.4	5.3	3.4	1.4	8.0	12.0	Q1
TPS62007QDGSRQ1	VSSOP	DGS	10	2500	330.0	12.4	5.3	3.4	1.4	8.0	12.0	Q1

TAPE AND REEL BOX DIMENSIONS

*All dimensions are nominal

Device	Package Type	Package Drawing	Pins	SPQ	Length (mm)	Width (mm)	Height (mm)
TPS62000QDGSRQ1	VSSOP	DGS	10	2500	350.0	350.0	43.0
TPS62004QDGSRQ1	VSSOP	DGS	10	2500	350.0	350.0	43.0
TPS62005QDGSRQ1	VSSOP	DGS	10	2500	350.0	350.0	43.0
TPS62007QDGSRQ1	VSSOP	DGS	10	2500	350.0	350.0	43.0

DGS0010A

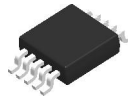

PACKAGE OUTLINE

VSSOP - 1.1 mm max height

SMALL OUTLINE PACKAGE

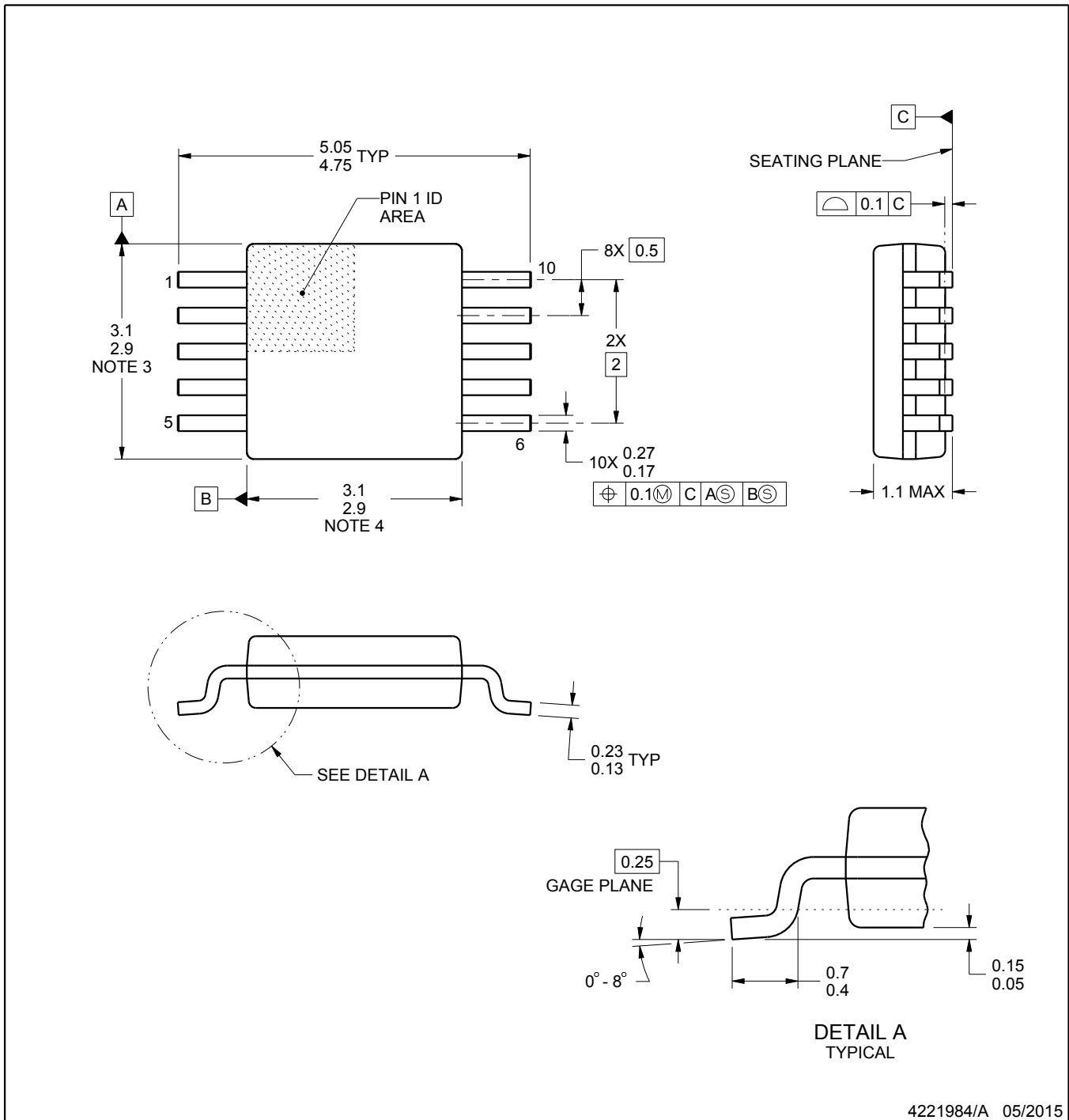

NOTES:

1. All linear dimensions are in millimeters. Any dimensions in parenthesis are for reference only. Dimensioning and tolerancing per ASME Y14.5M.
2. This drawing is subject to change without notice.
3. This dimension does not include mold flash, protrusions, or gate burrs. Mold flash, protrusions, or gate burrs shall not exceed 0.15 mm per side.
4. This dimension does not include interlead flash. Interlead flash shall not exceed 0.25 mm per side.
5. Reference JEDEC registration MO-187, variation BA.

EXAMPLE BOARD LAYOUT

DGS0010A

VSSOP - 1.1 mm max height

SMALL OUTLINE PACKAGE



LAND PATTERN EXAMPLE
SCALE:10X

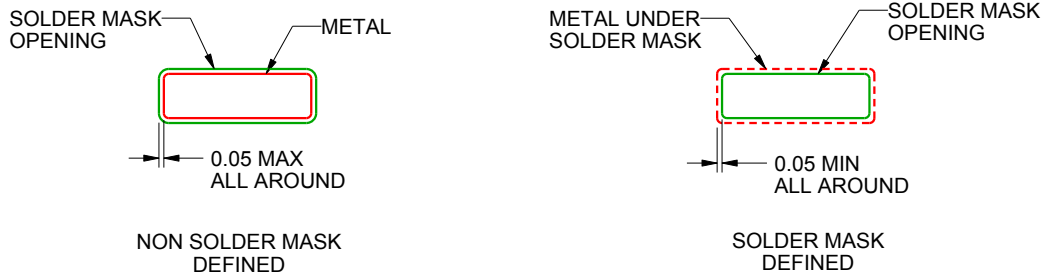

SOLDER MASK DETAILS
NOT TO SCALE

4221984/A 05/2015

NOTES: (continued)

- 6. Publication IPC-7351 may have alternate designs.
- 7. Solder mask tolerances between and around signal pads can vary based on board fabrication site.

EXAMPLE STENCIL DESIGN

DGS0010A

VSSOP - 1.1 mm max height

SMALL OUTLINE PACKAGE



SOLDER PASTE EXAMPLE
BASED ON 0.125 mm THICK STENCIL
SCALE:10X

4221984/A 05/2015

NOTES: (continued)

8. Laser cutting apertures with trapezoidal walls and rounded corners may offer better paste release. IPC-7525 may have alternate design recommendations.
9. Board assembly site may have different recommendations for stencil design.

IMPORTANT NOTICE AND DISCLAIMER

TI PROVIDES TECHNICAL AND RELIABILITY DATA (INCLUDING DATASHEETS), DESIGN RESOURCES (INCLUDING REFERENCE DESIGNS), APPLICATION OR OTHER DESIGN ADVICE, WEB TOOLS, SAFETY INFORMATION, AND OTHER RESOURCES "AS IS" AND WITH ALL FAULTS, AND DISCLAIMS ALL WARRANTIES, EXPRESS AND IMPLIED, INCLUDING WITHOUT LIMITATION ANY IMPLIED WARRANTIES OF MERCHANTABILITY, FITNESS FOR A PARTICULAR PURPOSE OR NON-INFRINGEMENT OF THIRD PARTY INTELLECTUAL PROPERTY RIGHTS.

These resources are intended for skilled developers designing with TI products. You are solely responsible for (1) selecting the appropriate TI products for your application, (2) designing, validating and testing your application, and (3) ensuring your application meets applicable standards, and any other safety, security, or other requirements. These resources are subject to change without notice. TI grants you permission to use these resources only for development of an application that uses the TI products described in the resource. Other reproduction and display of these resources is prohibited. No license is granted to any other TI intellectual property right or to any third party intellectual property right. TI disclaims responsibility for, and you will fully indemnify TI and its representatives against, any claims, damages, costs, losses, and liabilities arising out of your use of these resources.

TI's products are provided subject to TI's Terms of Sale (www.ti.com/legal/termsofsale.html) or other applicable terms available either on ti.com or provided in conjunction with such TI products. TI's provision of these resources does not expand or otherwise alter TI's applicable warranties or warranty disclaimers for TI products.

Mailing Address: Texas Instruments, Post Office Box 655303, Dallas, Texas 75265
Copyright © 2019, Texas Instruments Incorporated

Looking for pricing, stock, or lifecycle information?

Click below to explore more details on WIN SOURCE:

 [View TPS62000QDGSRQ1 on WIN SOURCE](#)

 [Texas Instruments](#) Information

Optimize Your Supply Chain with WIN SOURCE Solutions

-  Global Sourcing Solution
-  Obsolete Management
-  Cost Control Management
-  Shortage Management
-  Alternative Solution
-  Excess Inventory Management