



**THE DATASHEET OF
SN74AC373MDWREP**



SN74AC373-EP OCTAL D-TYPE TRANSPARENT LATCH WITH 3-STATE OUTPUTS

SCAS725 – OCTOBER 2003

- **Controlled Baseline**
 - One Assembly/Test Site, One Fabrication Site
- **Extended Temperature Performance of –55°C to 125°C**
- **Enhanced Diminishing Manufacturing Sources (DMS) Support**
- **Enhanced Product-Change Notification**
- **Qualification Pedigree†**
- **2-V to 6-V V_{CC} Operation**
- **Inputs Accept Voltages to 6 V**
- **Max t_{pd} of 9.5 ns at 5 V**
- **3-State Noninverting Outputs Drive Bus Lines Directly**
- **Full Parallel Access for Loading**

† Component qualification in accordance with JEDEC and industry standards to ensure reliable operation over an extended temperature range. This includes, but is not limited to, Highly Accelerated Stress Test (HAST) or biased 85/85, temperature cycle, autoclave or unbiased HAST, electromigration, bond intermetallic life, and mold compound life. Such qualification testing should not be viewed as justifying use of this component beyond specified performance and environmental limits.

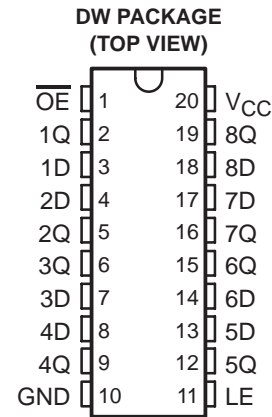

description/ordering information

This 8-bit latch features 3-state outputs designed specifically for driving highly capacitive or relatively low-impedance loads. The device is particularly suitable for implementing buffer registers, I/O ports, bidirectional bus drivers, and working registers.

The eight latches are D-type transparent latches. When the latch-enable (LE) input is high, the Q outputs follow the data (D) inputs. When LE is taken low, the Q outputs are latched at the logic levels set up at the D inputs.

A buffered output-enable (\overline{OE}) input can be used to place the eight outputs in either a normal logic state (high or low logic levels) or the high-impedance state. In the high-impedance state, the outputs neither load nor drive the bus lines significantly. The high-impedance state and increased drive provide the capability to drive bus lines in bus-organized systems without need for interface or pullup components.

\overline{OE} does not affect the internal operations of the latches. Old data can be retained or new data can be entered while the outputs are in the high-impedance state.

To ensure the high-impedance state during power up or power down, \overline{OE} should be tied to V_{CC} through a pullup resistor; the minimum value of the resistor is determined by the current-sinking capability of the driver.

ORDERING INFORMATION

| T_A | PACKAGE‡ | | ORDERABLE PART NUMBER | TOP-SIDE MARKING |
|----------------|-----------|---------------|-----------------------|------------------|
| –55°C to 125°C | SOIC – DW | Tape and reel | SN74AC373MDWREP | SAC373MEP |

‡ Package drawings, standard packing quantities, thermal data, symbolization, and PCB design guidelines are available at www.ti.com/sc/package.



Please be aware that an important notice concerning availability, standard warranty, and use in critical applications of Texas Instruments semiconductor products and disclaimers thereto appears at the end of this data sheet.

PRODUCTION DATA information is current as of publication date. Products conform to specifications per the terms of Texas Instruments standard warranty. Production processing does not necessarily include testing of all parameters.

 **TEXAS
INSTRUMENTS**

POST OFFICE BOX 655303 • DALLAS, TEXAS 75265

Copyright © 2003, Texas Instruments Incorporated

SN74AC373-EP OCTAL D-TYPE TRANSPARENT LATCH WITH 3-STATE OUTPUTS

SCAS725 – OCTOBER 2003

FUNCTION TABLE
(each latch)

| INPUTS | | | OUTPUT |
|-----------------|----|---|--------|
| \overline{OE} | LE | D | Q |
| L | H | H | H |
| L | H | L | L |
| L | L | X | Q_0 |
| H | X | X | Z |

logic diagram (positive logic)

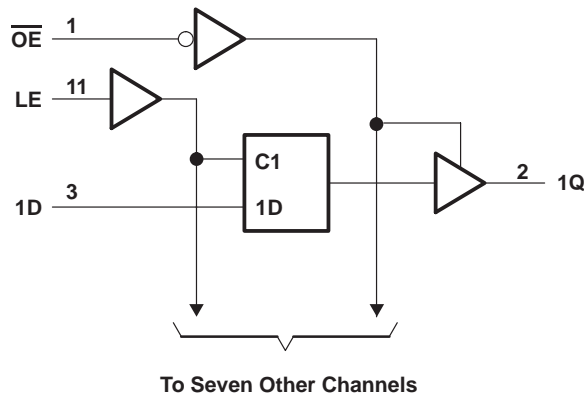

absolute maximum ratings over operating free-air temperature range (unless otherwise noted)†

| | |
|--|----------------------------|
| Supply voltage range, V_{CC} | -0.5 V to 7 V |
| Input voltage range, V_I (see Note 1) | -0.5 V to $V_{CC} + 0.5$ V |
| Output voltage range, V_O (see Note 1) | -0.5 V to $V_{CC} + 0.5$ V |
| Input clamp current, I_{IK} ($V_I < 0$ or $V_I > V_{CC}$) | ± 20 mA |
| Output clamp current, I_{OK} ($V_O < 0$ or $V_O > V_{CC}$) | ± 20 mA |
| Continuous output current, I_O ($V_O = 0$ to V_{CC}) | ± 50 mA |
| Continuous current through V_{CC} or GND | ± 200 mA |
| Package thermal impedance, θ_{JA} (see Note 2) | 58°C/W |
| Storage temperature range, T_{stg} (see Note 3) | -65°C to 150°C |

† Stresses beyond those listed under “absolute maximum ratings” may cause permanent damage to the device. These are stress ratings only, and functional operation of the device at these or any other conditions beyond those indicated under “recommended operating conditions” is not implied. Exposure to absolute-maximum-rated conditions for extended periods may affect device reliability.

- NOTES:
1. The input and output voltage ratings may be exceeded if the input and output current ratings are observed.
 2. The package thermal impedance is calculated in accordance with JESD 51-7.
 3. Long-term high-temperature storage and/or extended use at maximum recommended operating conditions may result in a reduction of overall device life. See http://www.ti.com/ep_quality for additional information on enhanced plastic packaging.

SN74AC373-EP OCTAL D-TYPE TRANSPARENT LATCH WITH 3-STATE OUTPUTS

SCAS725 – OCTOBER 2003

recommended operating conditions (see Note 4)

| | | MIN | MAX | UNIT |
|-----------------|------------------------------------|-------------------------|-----------------|------|
| V _{CC} | Supply voltage | 2 | 6 | V |
| V _{IH} | High-level input voltage | V _{CC} = 3 V | 2.1 | V |
| | | V _{CC} = 4.5 V | 3.15 | |
| | | V _{CC} = 5.5 V | 3.85 | |
| V _{IL} | Low-level input voltage | V _{CC} = 3 V | 0.9 | V |
| | | V _{CC} = 4.5 V | 1.35 | |
| | | V _{CC} = 5.5 V | 1.65 | |
| V _I | Input voltage | 0 | V _{CC} | V |
| V _O | Output voltage | 0 | V _{CC} | V |
| I _{OH} | High-level output current | V _{CC} = 3 V | -12 | mA |
| | | V _{CC} = 4.5 V | -24 | |
| | | V _{CC} = 5.5 V | -24 | |
| I _{OL} | Low-level output current | V _{CC} = 3 V | 12 | mA |
| | | V _{CC} = 4.5 V | 24 | |
| | | V _{CC} = 5.5 V | 24 | |
| Δt/Δv | Input transition rise or fall rate | | 8 | ns/V |
| T _A | Operating free-air temperature | -55 | 125 | °C |

NOTE 4: All unused inputs of the device must be held at V_{CC} or GND to ensure proper device operation. Refer to the TI application report, *Implications of Slow or Floating CMOS Inputs*, literature number SCBA004.

electrical characteristics over recommended operating free-air temperature range (unless otherwise noted)

| PARAMETER | TEST CONDITIONS | V _{CC} | T _A = 25°C | | | MIN | MAX | UNIT |
|-----------------|---|-----------------|-----------------------|-------|-----|-----|-----|------|
| | | | MIN | TYP | MAX | | | |
| V _{OH} | I _{OH} = -50 μA | 3 V | 2.9 | | 2.9 | | V | |
| | | 4.5 V | 4.4 | | 4.4 | | | |
| | | 5.5 V | 5.4 | | 5.4 | | | |
| | I _{OH} = -12 mA | 3 V | 2.56 | | 2.4 | | | |
| | | 4.5 V | 3.86 | | 3.7 | | | |
| | | 5.5 V | 4.86 | | 4.7 | | | |
| V _{OL} | I _{OL} = 50 μA | 3 V | | 0.1 | 0.1 | | V | |
| | | 4.5 V | | 0.1 | 0.1 | | | |
| | | 5.5 V | | 0.1 | 0.1 | | | |
| | I _{OL} = 12 mA | 3 V | | 0.36 | 0.5 | | | |
| | | 4.5 V | | 0.36 | 0.5 | | | |
| | | 5.5 V | | 0.36 | 0.5 | | | |
| I _I | V _I = V _{CC} or GND | 5.5 V | | ±0.1 | ±1 | μA | | |
| I _{OZ} | V _O = V _{CC} or GND | 5.5 V | | ±0.25 | ±5 | μA | | |
| I _{CC} | V _I = V _{CC} or GND, I _O = 0 | 5.5 V | | 4 | 80 | μA | | |
| C _i | V _I = V _{CC} or GND | 5 V | | 4.5 | | pF | | |



SN74AC373-EP

OCTAL D-TYPE TRANSPARENT LATCH

WITH 3-STATE OUTPUTS

SCAS725 – OCTOBER 2003

timing requirements over recommended operating free-air temperature range, $V_{CC} = 3.3 V \pm 0.3 V$ (unless otherwise noted) (see Figure 1)

| | | T _A = 25°C | | MIN | MAX | UNIT |
|-----------------|-----------------------------|-----------------------|-----|-----|-----|------|
| | | MIN | MAX | | | |
| t _w | Pulse duration, LE high | 5.5 | | 6.5 | | ns |
| t _{su} | Setup time, data before LE↓ | 5.5 | | 6.5 | | ns |
| t _h | Hold time, data after LE↓ | 1 | | 1 | | ns |

timing requirements over recommended operating free-air temperature range, $V_{CC} = 5 V \pm 0.5 V$ (unless otherwise noted) (see Figure 1)

| | | T _A = 25°C | | MIN | MAX | UNIT |
|-----------------|-----------------------------|-----------------------|-----|-----|-----|------|
| | | MIN | MAX | | | |
| t _w | Pulse duration, LE high | 4 | | 5 | | ns |
| t _{su} | Setup time, data before LE↓ | 4 | | 5 | | ns |
| t _h | Hold time, data after LE↓ | 1 | | 1 | | ns |

switching characteristics over recommended operating free-air temperature range, $V_{CC} = 3.3 V \pm 0.3 V$ (unless otherwise noted) (see Figure 1)

| PARAMETER | TO (INPUT) | TO (OUTPUT) | T _A = 25°C | | | MIN | MAX | UNIT |
|------------------|-----------------|-------------|-----------------------|-----|------|-----|------|------|
| | | | MIN | TYP | MAX | | | |
| t _{PLH} | D | Q | 1.5 | 10 | 13.5 | 1 | 16.5 | ns |
| t _{PHL} | | | 1.5 | 9.5 | 13.0 | 1 | 16 | |
| t _{PLH} | LE | Q | 1.5 | 10 | 13.5 | 1 | 16.5 | ns |
| t _{PHL} | | | 1.5 | 9.5 | 12.5 | 1 | 15 | |
| t _{PZH} | \overline{OE} | Q | 1.5 | 9 | 11.5 | 1 | 14 | ns |
| t _{PZL} | | | 1.5 | 8.5 | 11.5 | 1 | 13.5 | |
| t _{PHZ} | \overline{OE} | Q | 1.5 | 10 | 12.5 | 1 | 16 | ns |
| t _{PLZ} | | | 1.5 | 8 | 11.5 | 1 | 13 | |

switching characteristics over recommended operating free-air temperature range, $V_{CC} = 5 V \pm 0.5 V$ (unless otherwise noted) (see Figure 1)

| PARAMETER | TO (INPUT) | TO (OUTPUT) | T _A = 25°C | | | MIN | MAX | UNIT |
|------------------|-----------------|-------------|-----------------------|-----|-----|-----|------|------|
| | | | MIN | TYP | MAX | | | |
| t _{PLH} | D | Q | 1.5 | 7 | 9.5 | 1 | 11.5 | ns |
| t _{PHL} | | | 1.5 | 7 | 9.5 | 1 | 11.5 | |
| t _{PLH} | LE | Q | 1.5 | 7.5 | 9.5 | 1 | 12 | ns |
| t _{PHL} | | | 1.5 | 7 | 9.5 | 1 | 11 | |
| t _{PZH} | \overline{OE} | Q | 1.5 | 7 | 8.5 | 1 | 10.5 | ns |
| t _{PZL} | | | 1.5 | 6.5 | 8.5 | 1 | 10 | |
| t _{PHZ} | \overline{OE} | Q | 1.5 | 8 | 11 | 1 | 13.5 | ns |
| t _{PLZ} | | | 1.5 | 6.5 | 8.5 | 1 | 10.5 | |

operating characteristics, $V_{CC} = 5 V$, T_A = 25°C

| PARAMETER | TEST CONDITIONS | TYP | UNIT |
|-----------------|-------------------------------|-----------------------------------|-------|
| C _{pd} | Power dissipation capacitance | C _L = 50 pF, f = 1 MHz | 40 pF |



PARAMETER MEASUREMENT INFORMATION

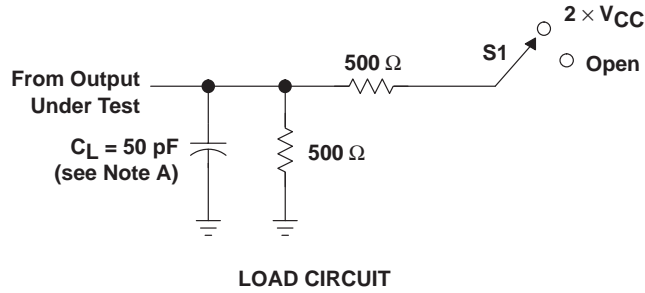

| TEST | S1 |
|-------------------|-------------------|
| t_{PLH}/t_{PHL} | Open |
| t_{PLZ}/t_{PZL} | $2 \times V_{CC}$ |
| t_{PHZ}/t_{PZH} | Open |

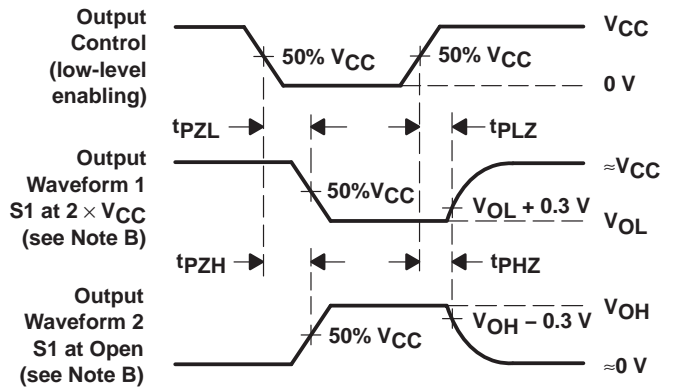
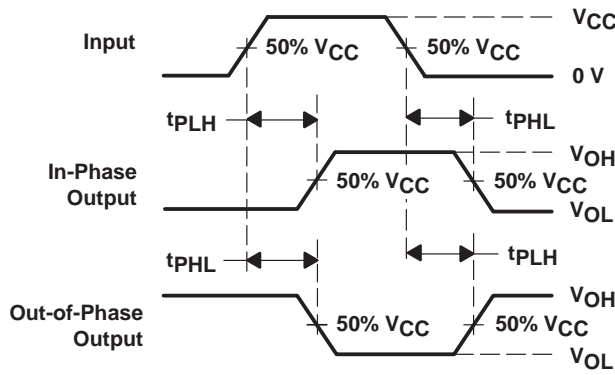
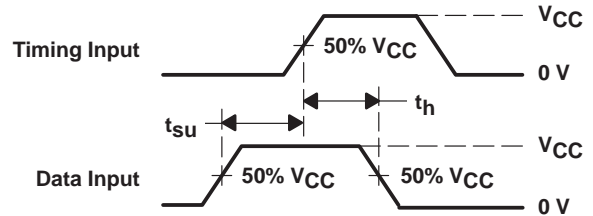
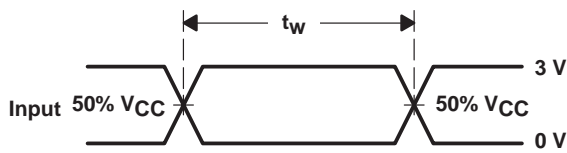

- NOTES: A. C_L includes probe and jig capacitance.
 B. Waveform 1 is for an output with internal conditions such that the output is low except when disabled by the output control. Waveform 2 is for an output with internal conditions such that the output is high except when disabled by the output control.
 C. All input pulses are supplied by generators having the following characteristics: $PRR \leq 1$ MHz, $Z_O = 50 \Omega$, $t_r \leq 2.5$ ns, $t_f \leq 2.5$ ns.
 D. The outputs are measured one at a time with one input transition per measurement.

Figure 1. Load Circuit and Voltage Waveforms

PACKAGING INFORMATION

| Orderable Device | Status ⁽¹⁾ | Package Type | Package Drawing | Pins | Package Qty | Eco Plan ⁽²⁾ | Lead/Ball Finish | MSL Peak Temp ⁽³⁾ |
|------------------|-----------------------|--------------|-----------------|------|-------------|-------------------------|------------------|------------------------------|
| SN74AC373MDWREP | ACTIVE | SOIC | DW | 20 | 2000 | Green (RoHS & no Sb/Br) | CU NIPDAU | Level-1-260C-UNLIM |
| V62/04621-01XE | ACTIVE | SOIC | DW | 20 | 2000 | Green (RoHS & no Sb/Br) | CU NIPDAU | Level-1-260C-UNLIM |

⁽¹⁾ The marketing status values are defined as follows:

ACTIVE: Product device recommended for new designs.

LIFEBUY: TI has announced that the device will be discontinued, and a lifetime-buy period is in effect.

NRND: Not recommended for new designs. Device is in production to support existing customers, but TI does not recommend using this part in a new design.

PREVIEW: Device has been announced but is not in production. Samples may or may not be available.

OBsolete: TI has discontinued the production of the device.

⁽²⁾ Eco Plan - The planned eco-friendly classification: Pb-Free (RoHS), Pb-Free (RoHS Exempt), or Green (RoHS & no Sb/Br) - please check <http://www.ti.com/productcontent> for the latest availability information and additional product content details.

TBD: The Pb-Free/Green conversion plan has not been defined.

Pb-Free (RoHS): TI's terms "Lead-Free" or "Pb-Free" mean semiconductor products that are compatible with the current RoHS requirements for all 6 substances, including the requirement that lead not exceed 0.1% by weight in homogeneous materials. Where designed to be soldered at high temperatures, TI Pb-Free products are suitable for use in specified lead-free processes.

Pb-Free (RoHS Exempt): This component has a RoHS exemption for either 1) lead-based flip-chip solder bumps used between the die and package, or 2) lead-based die adhesive used between the die and leadframe. The component is otherwise considered Pb-Free (RoHS compatible) as defined above.

Green (RoHS & no Sb/Br): TI defines "Green" to mean Pb-Free (RoHS compatible), and free of Bromine (Br) and Antimony (Sb) based flame retardants (Br or Sb do not exceed 0.1% by weight in homogeneous material)

⁽³⁾ MSL, Peak Temp. -- The Moisture Sensitivity Level rating according to the JEDEC industry standard classifications, and peak solder temperature.

Important Information and Disclaimer:The information provided on this page represents TI's knowledge and belief as of the date that it is provided. TI bases its knowledge and belief on information provided by third parties, and makes no representation or warranty as to the accuracy of such information. Efforts are underway to better integrate information from third parties. TI has taken and continues to take reasonable steps to provide representative and accurate information but may not have conducted destructive testing or chemical analysis on incoming materials and chemicals. TI and TI suppliers consider certain information to be proprietary, and thus CAS numbers and other limited information may not be available for release.

In no event shall TI's liability arising out of such information exceed the total purchase price of the TI part(s) at issue in this document sold by TI to Customer on an annual basis.

OTHER QUALIFIED VERSIONS OF SN74AC373-EP :

- Catalog: [SN74AC373](#)
- Military: [SN54AC373](#)

NOTE: Qualified Version Definitions:

- Catalog - TI's standard catalog product
- Military - QML certified for Military and Defense Applications

TAPE AND REEL INFORMATION



QUADRANT ASSIGNMENTS FOR PIN 1 ORIENTATION IN TAPE



*All dimensions are nominal

| Device | Package Type | Package Drawing | Pins | SPQ | Reel Diameter (mm) | Reel Width W1 (mm) | A0 (mm) | B0 (mm) | K0 (mm) | P1 (mm) | W (mm) | Pin1 Quadrant |
|-----------------|--------------|-----------------|------|------|--------------------|--------------------|---------|---------|---------|---------|--------|---------------|
| SN74AC373MDWREP | SOIC | DW | 20 | 2000 | 330.0 | 24.4 | 10.8 | 13.0 | 2.7 | 12.0 | 24.0 | Q1 |

TAPE AND REEL BOX DIMENSIONS



*All dimensions are nominal

| Device | Package Type | Package Drawing | Pins | SPQ | Length (mm) | Width (mm) | Height (mm) |
|-----------------|--------------|-----------------|------|------|-------------|------------|-------------|
| SN74AC373MDWREP | SOIC | DW | 20 | 2000 | 346.0 | 346.0 | 41.0 |

IMPORTANT NOTICE

Texas Instruments Incorporated and its subsidiaries (TI) reserve the right to make corrections, modifications, enhancements, improvements, and other changes to its products and services at any time and to discontinue any product or service without notice. Customers should obtain the latest relevant information before placing orders and should verify that such information is current and complete. All products are sold subject to TI's terms and conditions of sale supplied at the time of order acknowledgment.

TI warrants performance of its hardware products to the specifications applicable at the time of sale in accordance with TI's standard warranty. Testing and other quality control techniques are used to the extent TI deems necessary to support this warranty. Except where mandated by government requirements, testing of all parameters of each product is not necessarily performed.

TI assumes no liability for applications assistance or customer product design. Customers are responsible for their products and applications using TI components. To minimize the risks associated with customer products and applications, customers should provide adequate design and operating safeguards.

TI does not warrant or represent that any license, either express or implied, is granted under any TI patent right, copyright, mask work right, or other TI intellectual property right relating to any combination, machine, or process in which TI products or services are used. Information published by TI regarding third-party products or services does not constitute a license from TI to use such products or services or a warranty or endorsement thereof. Use of such information may require a license from a third party under the patents or other intellectual property of the third party, or a license from TI under the patents or other intellectual property of TI.

Reproduction of TI information in TI data books or data sheets is permissible only if reproduction is without alteration and is accompanied by all associated warranties, conditions, limitations, and notices. Reproduction of this information with alteration is an unfair and deceptive business practice. TI is not responsible or liable for such altered documentation. Information of third parties may be subject to additional restrictions.

Resale of TI products or services with statements different from or beyond the parameters stated by TI for that product or service voids all express and any implied warranties for the associated TI product or service and is an unfair and deceptive business practice. TI is not responsible or liable for any such statements.

TI products are not authorized for use in safety-critical applications (such as life support) where a failure of the TI product would reasonably be expected to cause severe personal injury or death, unless officers of the parties have executed an agreement specifically governing such use. Buyers represent that they have all necessary expertise in the safety and regulatory ramifications of their applications, and acknowledge and agree that they are solely responsible for all legal, regulatory and safety-related requirements concerning their products and any use of TI products in such safety-critical applications, notwithstanding any applications-related information or support that may be provided by TI. Further, Buyers must fully indemnify TI and its representatives against any damages arising out of the use of TI products in such safety-critical applications.

TI products are neither designed nor intended for use in military/aerospace applications or environments unless the TI products are specifically designated by TI as military-grade or "enhanced plastic." Only products designated by TI as military-grade meet military specifications. Buyers acknowledge and agree that any such use of TI products which TI has not designated as military-grade is solely at the Buyer's risk, and that they are solely responsible for compliance with all legal and regulatory requirements in connection with such use.

TI products are neither designed nor intended for use in automotive applications or environments unless the specific TI products are designated by TI as compliant with ISO/TS 16949 requirements. Buyers acknowledge and agree that, if they use any non-designated products in automotive applications, TI will not be responsible for any failure to meet such requirements.

Following are URLs where you can obtain information on other Texas Instruments products and application solutions:

Products

| | |
|-----------------------------|--|
| Amplifiers | amplifier.ti.com |
| Data Converters | dataconverter.ti.com |
| DSP | dsp.ti.com |
| Clocks and Timers | www.ti.com/clocks |
| Interface | interface.ti.com |
| Logic | logic.ti.com |
| Power Mgmt | power.ti.com |
| Microcontrollers | microcontroller.ti.com |
| RFID | www.ti-rfid.com |
| RF/IF and ZigBee® Solutions | www.ti.com/lprf |

Applications

| | |
|--------------------|--|
| Audio | www.ti.com/audio |
| Automotive | www.ti.com/automotive |
| Broadband | www.ti.com/broadband |
| Digital Control | www.ti.com/digitalcontrol |
| Medical | www.ti.com/medical |
| Military | www.ti.com/military |
| Optical Networking | www.ti.com/opticalnetwork |
| Security | www.ti.com/security |
| Telephony | www.ti.com/telephony |
| Video & Imaging | www.ti.com/video |
| Wireless | www.ti.com/wireless |

Mailing Address: Texas Instruments, Post Office Box 655303, Dallas, Texas 75265
Copyright © 2008, Texas Instruments Incorporated

Looking for pricing, stock, or lifecycle information?

Click below to explore more details on WIN SOURCE:

 [View SN74AC373MDWREP](#) on WIN SOURCE

 [Texas Instruments](#) Information

Optimize Your Supply Chain with WIN SOURCE Solutions

-  Global Sourcing Solution
-  Obsolete Management
-  Cost Control Management
-  Shortage Management
-  Alternative Solution
-  Excess Inventory Management