



AK4388A

192kHz 24-Bit 2ch $\Delta\Sigma$ DAC

GENERAL DESCRIPTION

The AK4388A offers the perfect mix for cost and performance based audio systems. Using AKM's multi bit architecture for its modulator, the AK4388A delivers a wide dynamic range while preserving linearity for improved THD+N performance. The AK4388A integrates a combination of SCF and CTF filters increasing performance for systems with excessive clock jitter. The 24 Bit word length and 192kHz sampling rate make this part ideal for a wide range of applications including DVD-Audio. The AK4388A is offered in a space saving 16pin TSSOP package.

FEATURES

- Sampling Rate Ranges from 8kHz to 192kHz
- 128 times Oversampling (Normal Speed Mode)
- 64 times Oversampling (Double Speed Mode)
- 32 times Oversampling (Quad Speed Mode)
- 24-Bit 8 times FIR Digital Filter
- SCF with High Tolerance to Clock Jitter
- Single Ended Output Buffer
- Digital de-emphasis
- Soft mute
- I/F format: 24-Bit MSB justified, 24/16-Bit LSB justified or I²S
- Master clock: 256fs, 384fs, 512fs, 768fs or 1152fs (Normal Speed Mode)
256fs or 384fs (Double Speed Mode)
128fs, 192fs (Quad Speed Mode)
- THD+N: -90dB
- Dynamic Range: 106dB
- Power supply: 4.5 to 5.5V
- Very Small Package: 16pin TSSOP (6.4mm x 5.0mm)
- AK4384 Parallel Mode Compatible

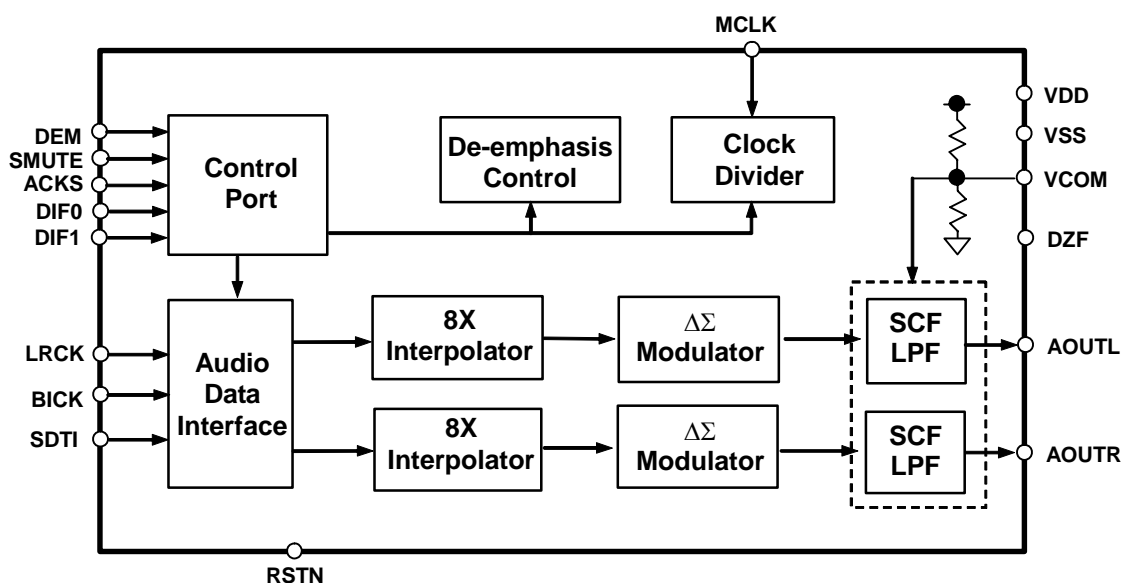

■ Ordering Guide

AK4388AET
AKD4388A

-20°C ~ +85°C
Evaluation Board for the AK4388A

16pin TSSOP (0.65mm pitch)

■ Pin Layout

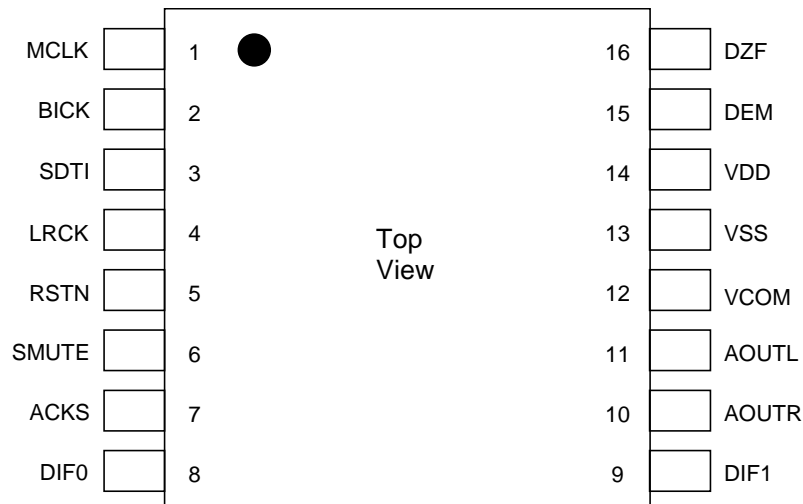

■ Compatibility with AK4384, AK4388

1. Function

Functions	AK4384	AK4388	AK4388A
THD+N	-94dB	-90dB	←
Output Voltage	3.4Vpp	3.2Vpp	←
Slow Roll-Off Filter	Available	Not Available	←
Mode Setting	Serial/Parallel	Parallel	←
DEM in Parallel control	Not Available	Available	←
Audio Format in Parallel control	24-Bit I ² S 24-Bit MSB justified	24/16-Bit I ² S 24-Bit MSB justified 24/16-Bit LSB justified	←
Zero Data Detect Pin	2 pins	1 pin	←
MCLK, LRCK, BICK Clock Stop (RSTN pin= "H")	Not Available	Not Available	Available

2. Pin Configuration

AK4388/A	AK4384	Pin#	Pin#	AK4384	AK4388/A
MCLK	MCLK	1	16	DZFL	DZF
BICK	BICK	2	15	DZFR	DEM (pd)
SDTI	SDTI	3	14	VDD	VDD
LRCK	LRCK	4	13	VSS	VSS
RSTN	PDN	5	12	VCOM	VCOM
SMUTE	SMUTE/CSN	6	11	AOUTL	AOUTL
ACKS	ACKS/CCLK	7	10	AOUTR	AOUTR
DIF0	DIF0/CDTI	8	9	P/S (pu)	DIF1 (pu)

: Deference between AK4384

* pu: Pull-up, pd: Pull-down

PIN/FUNCTION

No.	Pin Name	I/O	Function
1	MCLK	I	Master Clock Input Pin An external TTL clock must be input on this pin.
2	BICK	I	Audio Serial Data Clock Pin
3	SDTI	I	Audio Serial Data Input Pin
4	LRCK	I	L/R Clock Pin
5	RSTN	I	Reset Mode Pin When at "L", the AK4388A is in power-down mode and is held in reset. The AK4388A must always be reset upon power-up.
6	SMUTE	I	Soft Mute Pin "H": Enable, "L": Disable
7	ACKS	I	Auto Setting Mode Pin "L": Manual Setting Mode, "H": Auto Setting Mode
8	DIF0	I	Audio Data Interface Format Pin
9	DIF1	I	Audio Data Interface Format Pin (Internal pull-up pin)
10	AOUTR	O	Rch Analog Output Pin
11	AOUTL	O	Lch Analog Output Pin
12	VCOM	O	Common Voltage Pin, VDD/2 Normally connected to VSS with a 10 μ F electrolytic cap.
13	VSS	-	Ground Pin
14	VDD	-	Power Supply Pin 4.5V~5.5V
15	DEM	I	De-emphasis Mode Pin (Internal pull-down pin) When at "H", the de-emphasis filter is available.
16	DZF	O	Zero Input Detect Pin

Note: All input pins except pull-up and pull-down pins must not be left floating.

ABSOLUTE MAXIMUM RATINGS

(VSS=0V; Note 1)

Parameter	Symbol	min	max	Units
Power Supply	VDD	-0.3	6.0	V
Input Current (any pins except for supplies)	IIN	-	± 10	mA
Input Voltage	VIND	-0.3	VDD+0.3	V
Ambient Operating Temperature	Ta	-20	85	$^{\circ}$ C
Storage Temperature	Tstg	-65	150	$^{\circ}$ C

Note 1. All voltages with respect to ground.

WARNING: Operation at or beyond these limits may results in permanent damage to the device.
Normal operation is not guaranteed at these extremes.

RECOMMENDED OPERATING CONDITIONS

(VSS=0V; Note 1)

Parameter	Symbol	min	typ	max	Units
Power Supply	VDD	4.5	5.0	5.5	V

*AKM assumes no responsibility for the usage beyond the conditions in this datasheet.

ANALOG CHARACTERISTICS

(Ta = 25°C; VDD = 5.0V; fs = 44.1kHz; BICK = 64fs; Signal Frequency = 1kHz; 24bit Input Data; Measurement frequency = 20Hz ~ 20kHz; RL ≥ 5kΩ; unless otherwise specified)

Parameter		min	typ	max	Units	
Resolution				24	Bits	
Dynamic Characteristics (Note 2)						
THD+N	fs=44.1kHz		0dBFS	-90	-80	dB
	BW=20kHz		-60dBFS	-42	-	dB
	fs=96kHz		0dBFS	-90	-	dB
	BW=40kHz		-60dBFS	-39	-	dB
	fs=192kHz		0dBFS	-85	-	dB
	BW=40kHz		-60dBFS	-39	-	dB
Dynamic Range (-60dBFS with A-weighted)	(Note 3)	98	106		dB	
S/N (A-weighted)	(Note 4)	98	106		dB	
Interchannel Isolation (1kHz)		90	100		dB	
Interchannel Gain Mismatch			0.2	0.5	dB	
DC Accuracy						
Gain Drift			100	-	ppm/°C	
Output Voltage	(Note 5)	2.95	3.20	3.45	Vpp	
Load Resistance	(Note 6)	5			kΩ	
Load Capacitance				25	pF	
Power Supplies						
Power Supply Current (VDD)						
Normal Operation (RSTN pin = "H", fs ≤ 96kHz)			16	-	mA	
Normal Operation (RSTN pin = "H", fs = 192kHz)			18	27	mA	
Power-Down Mode (RSTN pin = "L")	(Note 7)		60	160	μA	

Note 2. Measured by Audio Precision (System Two). Refer to the evaluation board manual.

Note 3. 100dB at 16bit data.

Note 4. S/N does not depend on input bit length.

Note 5. Full-scale voltage (0dB). Output voltage scales with the voltage of VDD, AOOUT (typ.@0dB) = 3.20Vpp × VDD/5.

Note 6. For AC-load.

Note 7. The DIF1 pin is held to VDD and the other all digital inputs including clock pins (MCLK, BICK and LRCK) are held to VSS.

FILTER CHARACTERISTICS

(Ta = 25°C; VDD = 4.5 ~ 5.5V; fs = 44.1kHz)

Parameter	Symbol	min	typ	max	Units		
Digital filter (DEM = OFF)							
Passband		±0.05dB (Note 8)	0		kHz		
		-6.0dB	-	22.05	20.0	kHz	
Stopband		(Note 8)	SB	24.1	kHz		
Passband Ripple			PR		± 0.02	dB	
Stopband Attenuation			SA	54		dB	
Group Delay			GD	-	19.3	1/fs	
De-emphasis Filter (DEM = ON)							
De-emphasis Error (DC referenced)		fs = 32kHz		-	-	-1.5/0	dB
		fs = 44.1kHz		-	-	-0.2/+0.2	dB
		fs = 48kHz		-	-	0/+0.6	dB
Digital Filter + LPF (DEM = OFF)							
Frequency Response	20.0kHz	fs=44.1kHz	FR	-	±0.2	-	dB
	40.0kHz	fs=96kHz	FR	-	±0.3	-	dB
	80.0kHz	fs=192kHz	FR	-	+0.1/-0.6	-	dB

Note 8. The passband and stopband frequencies scale with fs(system sampling rate). For example, PB=0.4535×fs (@±0.05dB), SB=0.546×fs.

Note 9. Calculated delay time caused by digital filter. This time is measured from setting the 16/24bit data of both channels to input register to the output of the analog signal.

DC CHARACTERISTICS

(Ta = 25°C; VDD = 4.5 ~ 5.5V)

Parameter	Symbol	min	typ	max	Units
High-Level Input Voltage	VIH	2.2	-	-	V
Low-Level Input Voltage	VIL	-	-	0.8	V
High-Level Output Voltage (Iout = -80μA)	VOH	VDD-0.4	-	-	V
Low-Level Output Voltage (Iout = 80μA)	VOL	-	-	0.4	V
Input Leakage Current (Note 10)	Iin	-	-	± 10	μA

Note 10. Except for the DIF1 and DEM pins. The DIF1 pin has internal pull-up resistor, the DEM pin has internal pull-down resistor, nominally 100kΩ. (typ. 100kΩ)

SWITCHING CHARACTERISTICS

(Ta = 25°C; VDD = 4.5 ~ 5.5V; CL = 20pF)

Parameter	Symbol	min	typ	max	Units
Master Clock Frequency	fCLK	2.048	11.2896	36.864	MHz
Duty Cycle	dCLK	40		60	%
LRCK Frequency					
Normal Speed Mode	fsn	8		48	kHz
Double Speed Mode	fsd	32		96	kHz
Quad Speed Mode	fsq	120		192	kHz
Duty Cycle	Duty	45		55	%
Audio Interface Timing					
BICK Period					
Normal Speed Mode	tBCK	1/128fs			ns
Double/Quad Speed Mode	tBCK	1/64fs			ns
BICK Pulse Width Low	tBCKL	30			ns
Pulse Width High	tBCKH	30			ns
BICK “↑” to LRCK Edge (Note 11)	tBLR	20			ns
LRCK Edge to BICK “↑” (Note 11)	tLRB	20			ns
SDTI Hold Time	tSDH	20			ns
SDTI Setup Time	tSDS	20			ns
Reset Timing					
RSTN Pulse Width (Note 12)	tRST	150			ns

Note 11. BICK rising edge must not occur at the same time as LRCK edge.

Note 12. The AK4388A can be reset by bringing RSTN pin = “L” → “H”.

■ Timing Diagram

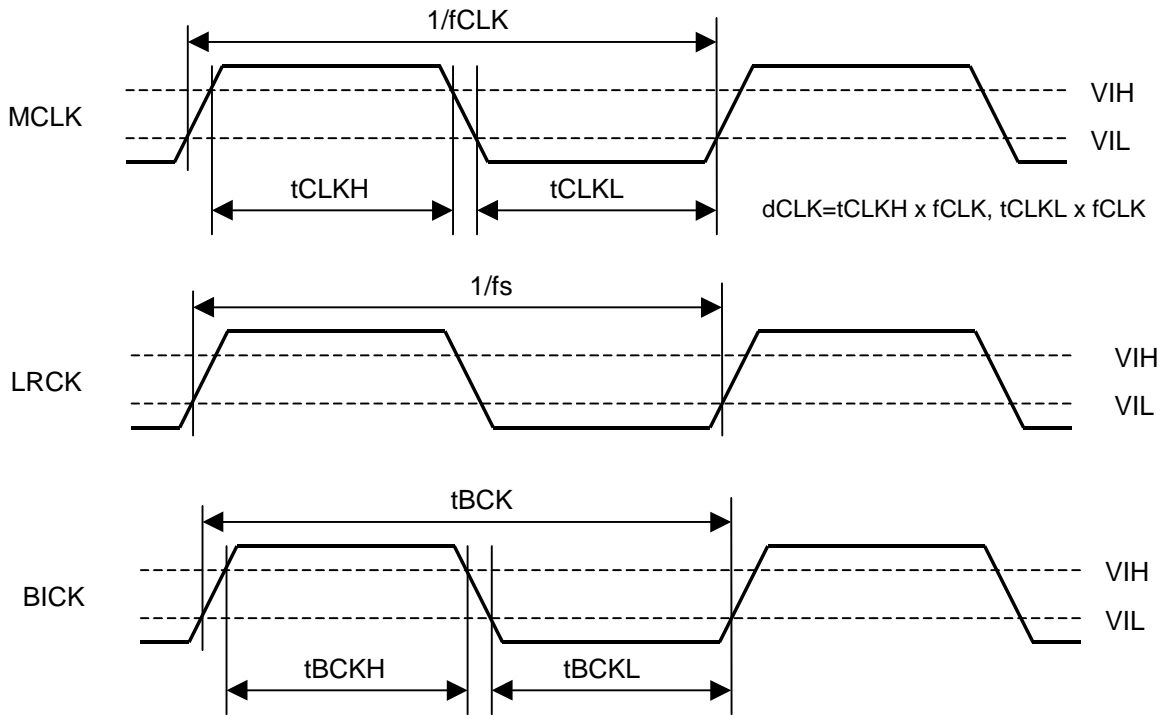

Figure 1. Clock Timing

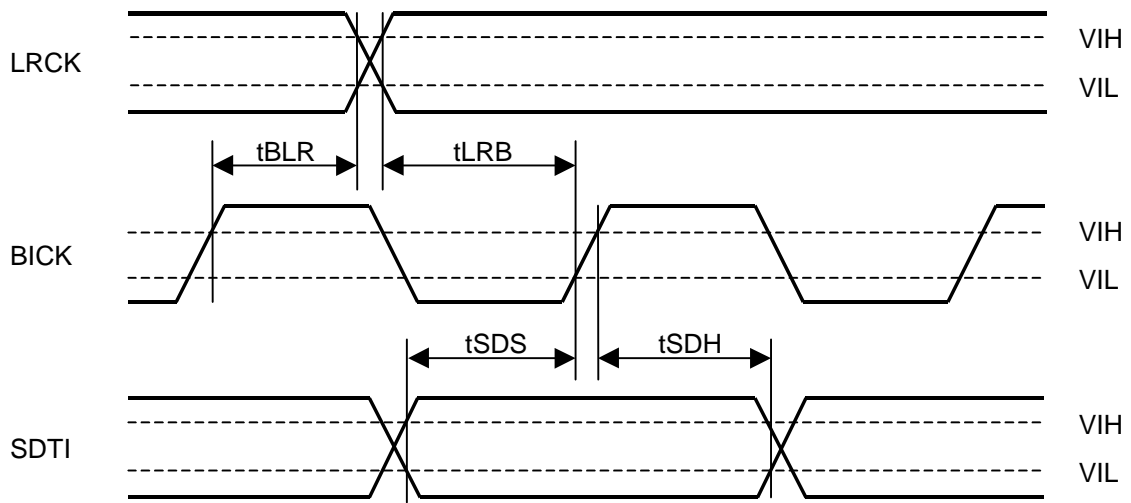

Figure 2. Serial Interface Timing

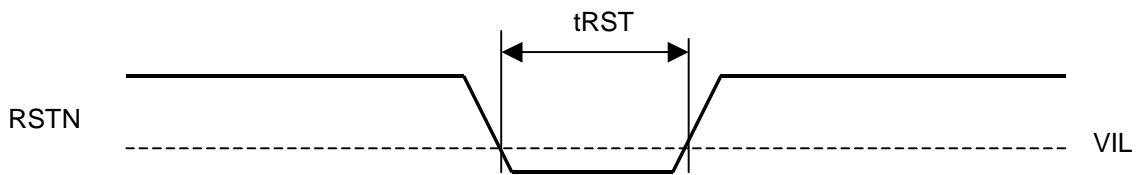

Figure 3. Power-down Timing

OPERATION OVERVIEW

■ System Clock

The external clocks, which are required to operate the AK4388A, are MCLK, LRCK and BICK. The master clock (MCLK) should be synchronized with LRCK but the phase is not critical. The MCLK is used to operate the digital interpolation filter and the delta-sigma modulator. There are two methods to set MCLK frequency. In Manual Setting Mode (ACKS pin = "L", Normal Speed Mode), the frequency of MCLK is set automatically (Table 1). In Auto Setting Mode (ACKS pin = "H"), as MCLK frequency is detected automatically (Table 2), and the internal master clock becomes the appropriate frequency (Table 3).

LRCK fs	MCLK					BICK 64fs
	256fs	384fs	512fs	768fs	1152fs	
32.0kHz	8.1920MHz	12.2880MHz	16.3840MHz	24.5760MHz	36.8640MHz	2.0480MHz
44.1kHz	11.2896MHz	16.9344MHz	22.5792MHz	33.8688MHz	N/A	2.8224MHz
48.0kHz	12.2880MHz	18.4320MHz	24.5760MHz	36.8640MHz	N/A	3.0720MHz

Table 1. System Clock Example (Manual Setting Mode, ACKS pin = "L", Normal Speed Mode)

MCLK		Mode	Sampling Rate
1152fs		Normal	8kHz~32kHz
512fs	768fs	Normal	8kHz~48kHz
256fs	384fs	Double	32kHz~96kHz
128fs	192fs	Quad	120kHz~192kHz

Table 2. Sampling Speed (Auto Setting Mode, ACKS pin = "H")

LRCK fs	MCLK (MHz)						
	128fs	192fs	256fs	384fs	512fs	768fs	1152fs
32.0kHz	-	-	8.1920	12.2880	16.3840	24.5760	36.8640
44.1kHz	-	-	11.2896	16.9344	22.5792	33.8688	-
48.0kHz	-	-	12.2880	18.4320	24.5760	36.8640	-
88.2kHz	-	-	22.5792	33.8688	-	-	-
96.0kHz	-	-	24.5760	36.8640	-	-	-
176.4kHz	22.5792	33.8688	-	-	-	-	-
192.0kHz	24.5760	36.8640	-	-	-	-	-

Table 3. System Clock Example (Auto Setting Mode, ACKS pin = "H")

When MCLK= 256fs/384fs, the Auto Setting Mode supports sampling rate of 32kHz~96kHz (Table 2). When the sampling rate is 32kHz~48kHz, DR and S/N will degrade by approximately 3dB as compared to when MCLK= 512fs/768fs.

ACKS pin	MCLK	DR, S/N
L	256fs/384fs/512fs/768fs	106dB
H	256fs/384fs	103dB
H	512fs/768fs	106dB

Table 4. Relationship between MCLK frequency and DR, S/N (fs= 44.1kHz)

■ Audio Serial Interface Format

Data is shifted in via the SDTI pin using BICK and LRCK inputs. The DIF0-1 as shown in Table 5 can select four serial data modes. The DIF1 pin is internal pull-up pin. In all modes the serial data is MSB-first, 2's compliment format and is latched on the rising edge of BICK.

Mode	DIF1	DIF0	SDTI Format	BICK	Figure
0	L	L	16bit LSB justified	≥32fs	Figure 4
1	L	H	24bit LSB justified	≥48fs	Figure 5
2	H	L	24bit MSB justified	≥48fs	Figure 6
3	H	H	16/24bit I ² S Compatible	≥48fs or 32fs	Figure 7

Table 5. Audio Data Formats

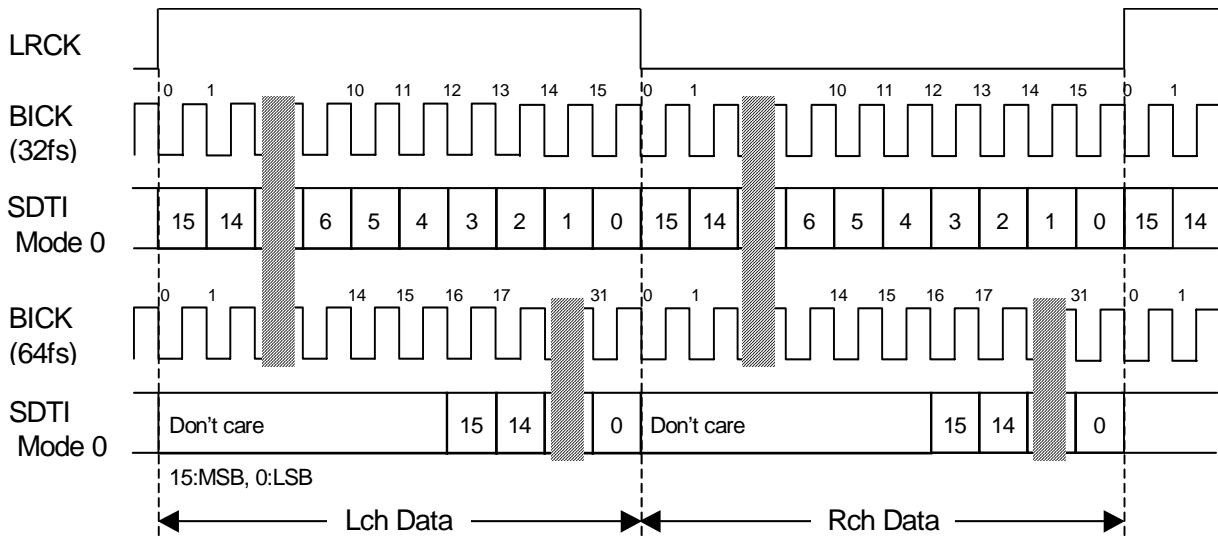

Figure 4. Mode 0 Timing

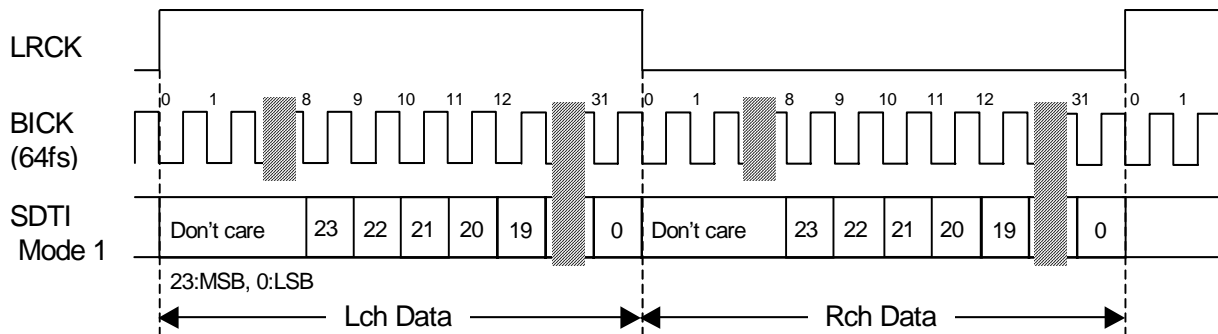

Figure 5. Mode 1 Timing

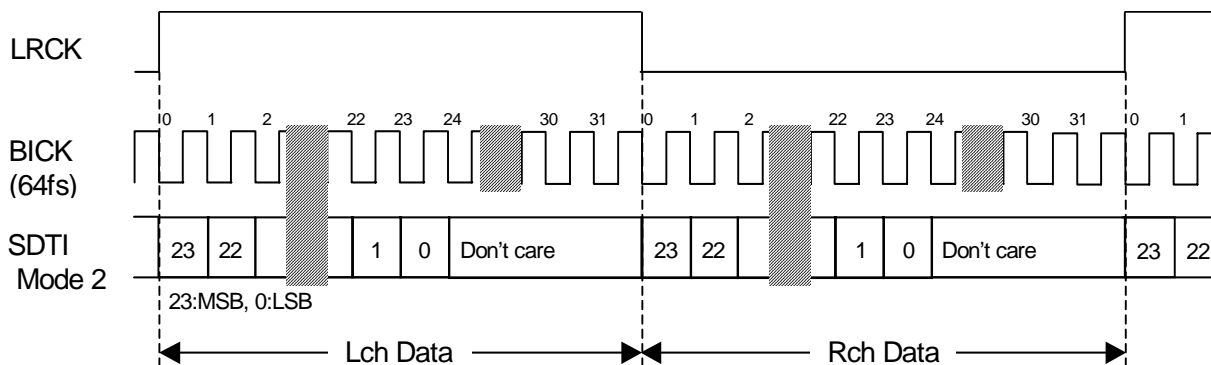

Figure 6. Mode 2 Timing

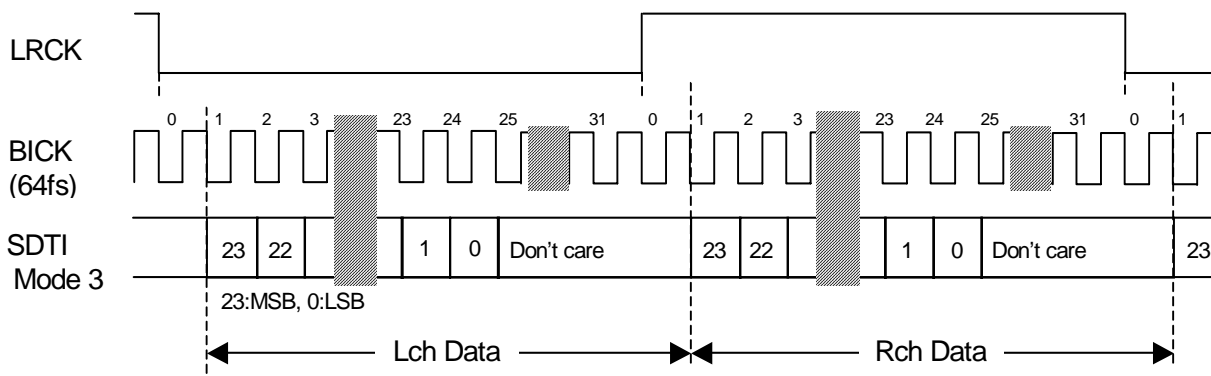

Figure 7. Mode 3 Timing

■ De-emphasis Filter

A digital de-emphasis filter is built-in ($t_c = 50/15\mu s$). The DEM pin is internal pull-down pin. The digital de-emphasis filter is enabled by setting the DEM pin to “H”. Refer to “FILTER CHARACTERISTICS” regarding the gain error when the de-emphasis filter is enabled. In case of double speed mode (MCLK=256fs/384fs) and quad speed mode (MCLK=128fs/192fs), the digital de-emphasis filter is always off.

DEM pin	De-emphasis Filter
1	ON
0	OFF

(default)

Table 6. De-emphasis Filter Control (Normal Speed Mode)

■ Zero Detection

When the input data at both channels are continuously zeros for 8192 LRCK cycles, the DZF pin goes to “H”. The DZF pin immediately returns to “L” if input data of both channels are not zero (Figure 8).

■ Soft Mute Operation

Soft mute operation is performed at digital domain. When the SMUTE pin goes to “H”, the output signal is attenuated by $-\infty$ in 1024 LRCK cycles. When the SMUTE pin is returned to “L”, the mute is cancelled and the output attenuation gradually changes to 0dB in 1024 LRCK cycles. If the soft mute is cancelled within the 1024 LRCK cycles, the attenuation is discontinued and returned to 0dB in the same cycle. The soft mute is effective for changing the signal source without stopping the signal transmission.

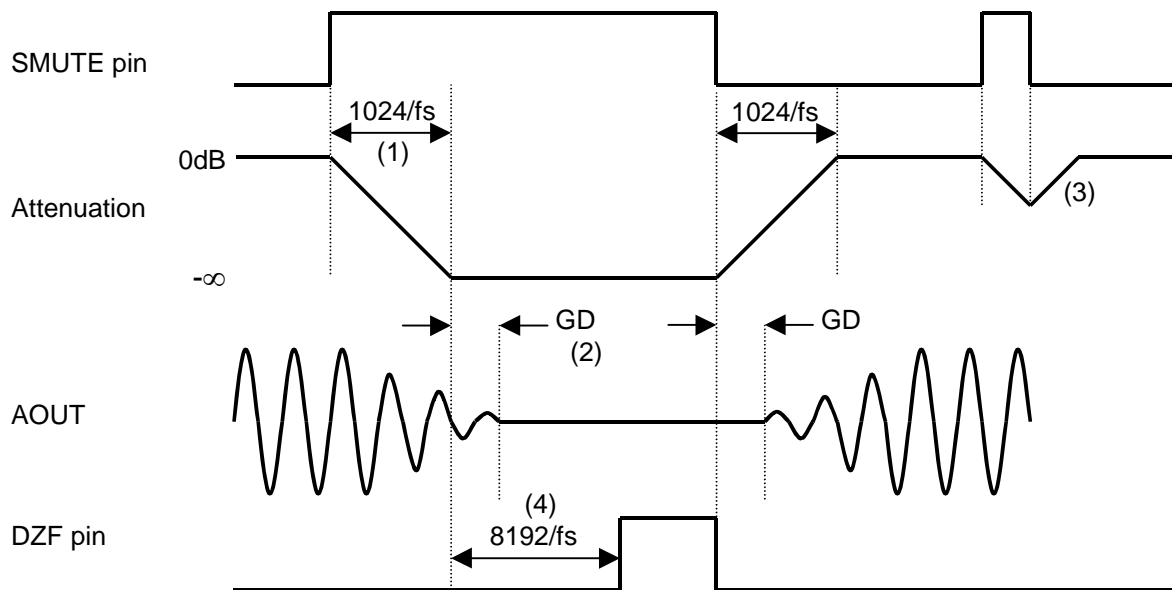

Notes:

- (1) 1024LRCK cycles ($1024/fs$) at input data is attenuated to $-\infty$.
- (2) The analog output corresponding to the digital input has group delay, GD.
- (3) If the soft mute is cancelled before attenuating to $-\infty$, the attenuation is discontinued and returned to ATT level by the same cycle.
- (4) When the input data at both channels are continuously zeros for 8192 LRCK cycles, the DZF pin goes to “H”. The DZF pin immediately returns to “L” if input data are not zero.

Figure 8. Soft Mute and Zero Detection

■ System Reset

The AK4388A must be reset once by bringing the RSTN pin = "L" upon power-up. The AK4388A is powered up and the internal timing starts clocking by LRCK "↑" after exiting reset by MCLK. The AK4388A is in reset state until LRCK is input.

■ Power ON/OFF timing

The AK4388A is placed in the power-down mode by bringing the RSTN pin "L" and the registers are initialized. The analog outputs go to VCOM (VDD/2). Since click noise occurs at the edge of the RSTN signal, the analog output should be muted externally if click noise adversely affects system application.

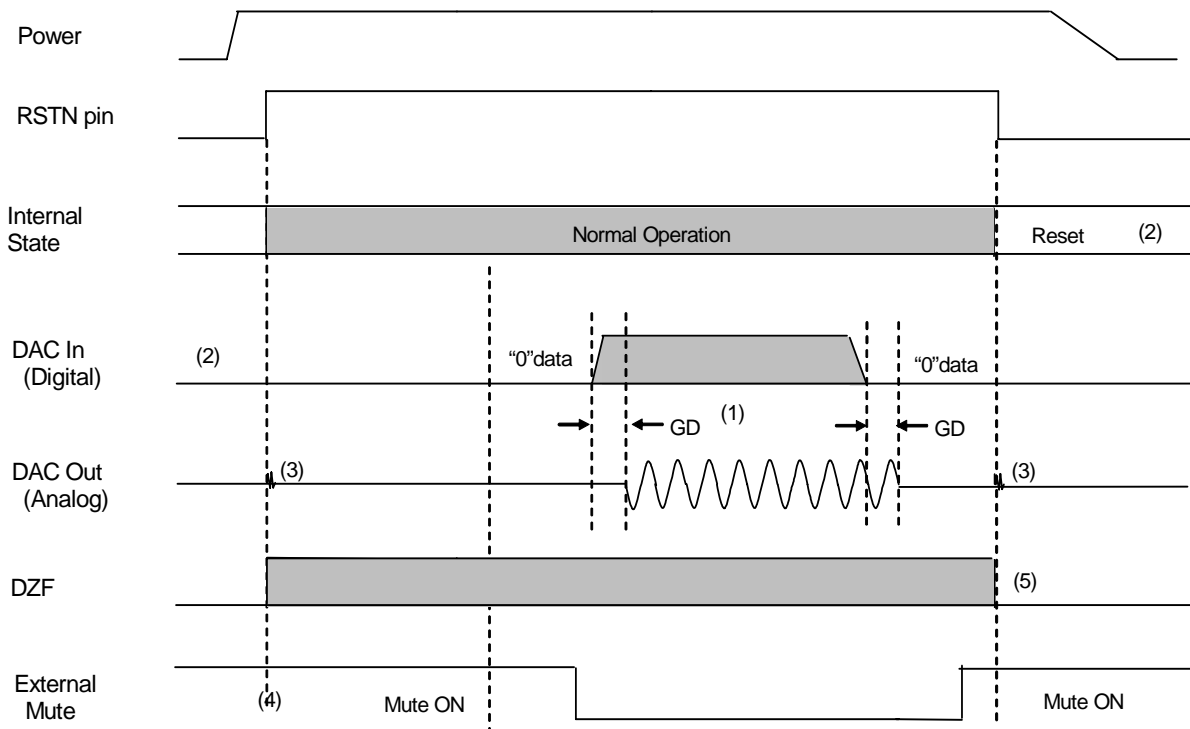

Notes:

- (1) The analog output corresponding to digital input has the group delay (GD).
- (2) Analog outputs are VCOM (VDD/2) in power-down mode.
- (3) Click noise occurs at the edge of RSTN signal. This noise is output even if "0" data is input.
- (4) Mute the analog output externally if the click noise (3) influences the system application. The timing example is shown in this figure.
- (5) DZF pins are "L" in the power-down mode (RSTB pin = "L").

Figure 9. Power-down/up Sequence Example

■ Reset Function (MCLK, LRCK or BICK stop)

When the MCLK, LRCK or BICK stops, the digital circuit of the AK4388A is placed in power-down mode. When the MCLK, LRCK and BICK are restarted, power-down mode is released and the AK4388A returns to normal operation mode.

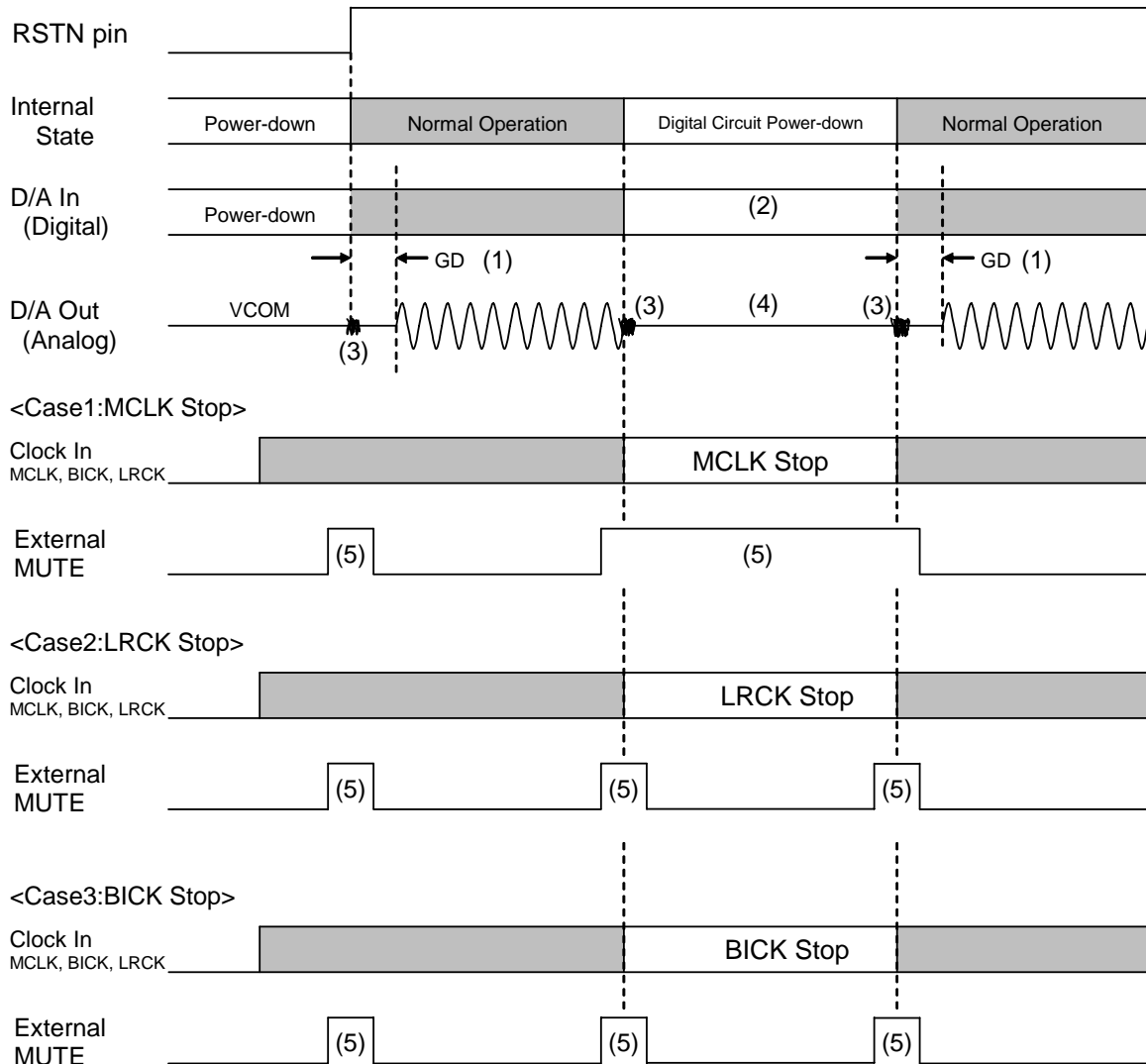

Notes.

- (1) The analog output corresponding to a specific digital input has group delay (GD).
- (2) Digital data can be stopped. The click noise, after MCLK, LRCK and BICK are input again, can be reduced by inputting the "0" data during this period.
- (3) Click noise occurs within 20usec or 20usec + 3 ~ 4LRCK from the rising edge ("↑") of the RSTN pin or MCLK inputs. Click noise also occurs within 20usec when MCLK, LRCK or BICK is stopped.
- (4) The analog output becomes idle voltage when MCLK is stopped. It becomes VCOM voltage if LRCK or BICK is stopped when MCLK is input.
- (5) Mute the analog output externally if click noise (3) adversely affect system performance.

Figure 10. Clock Stop Sequence

SYSTEM DESIGN

Figure 11 shows the system connection diagram. An evaluation board (AKD4388A) is available for fast evaluation as well as suggestions for peripheral circuitry.

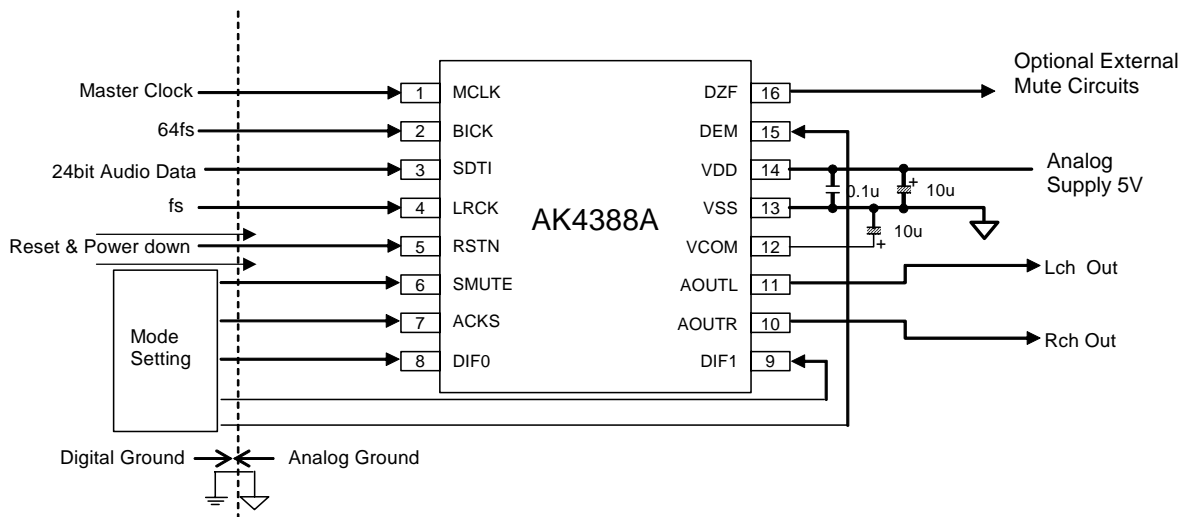

Figure 11. Typical Connection Diagram

Notes:

- LRCK = fs, BICK=64fs.
- When AOUT drives capacitive load, a resistor must be connected in series between AOUT and capacitive load.
- All input pins except DIF1 and DEM pins must not be left floating.

1. Grounding and Power Supply Decoupling

VDD and VSS are supplied from analog supply and must be separated from system digital supply. Decoupling capacitor, especially 0.1μF ceramic capacitor, for high frequency should be placed as near to VDD as possible. The differential voltage between VDD and VSS pins set the analog output range.

2. Analog Outputs

The analog outputs are single-ended and centered on the VCOM voltage. The output signal range is typically 3.20Vpp (typ@VDD=5V). The internal switched-capacitor filter and continuous-time filter attenuate the noise generated by the delta-sigma modulator beyond the audio passband. The output voltage is a positive full scale for 7FFFFFFH (@24bit) and a negative full scale for 800000H (@24bit). The ideal output is VCOM voltage for 000000H (@24bit).

The analog outputs have DC offsets of VCOM + a few mV. This DC offsets on analog outputs are eliminated by AC coupling. Figure 12 shows an example of the external LPF with 3.20Vpp (1.13Vrms) output. Figure 13 shows an example of the external LPF with 2Vrms output.

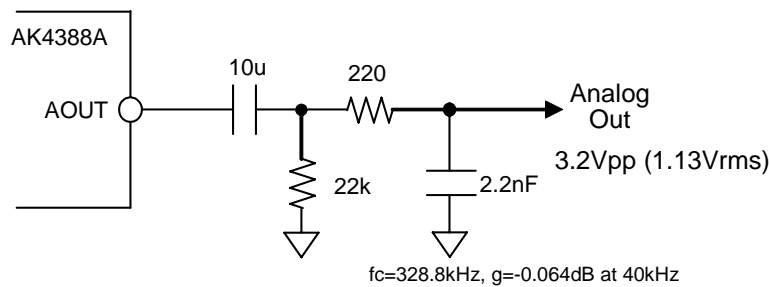

Figure 12. External 1st order LPF Circuit Example (simple)

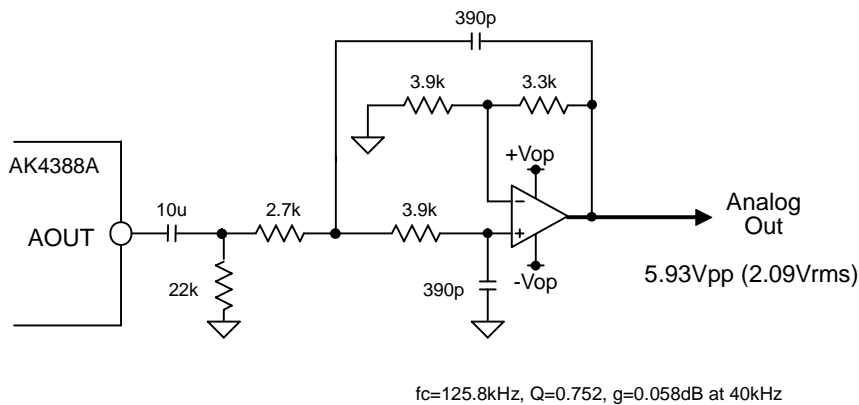
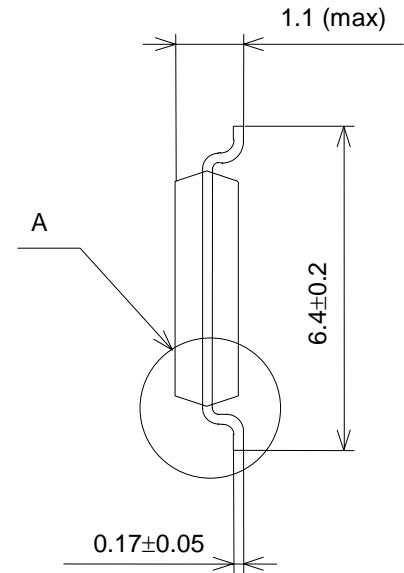
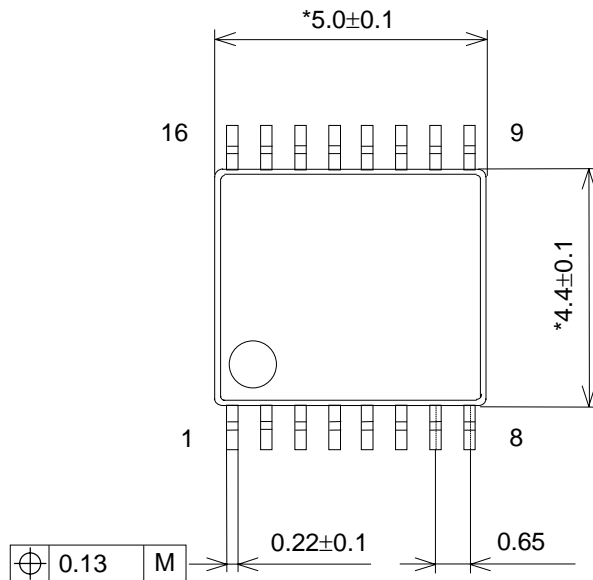

Figure 13. External 2nd order LPF Circuit Example (using op-amp with dual power supplies)

PACKAGE

16pin TSSOP (Unit: mm)



Detail A

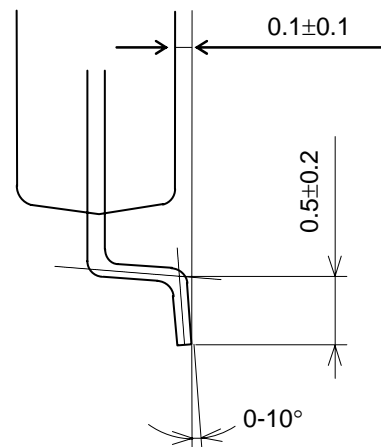
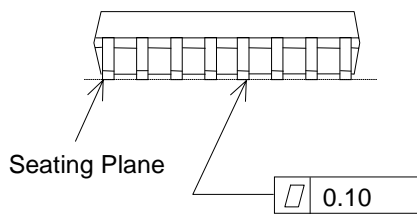

NOTE: Dimension "*" does not include mold flash.

■ Package & Lead frame material

Package molding compound:	Epoxy
Lead frame material:	Cu
Lead frame surface treatment:	Solder (Pb free) plate

MARKING (AK4388AET)

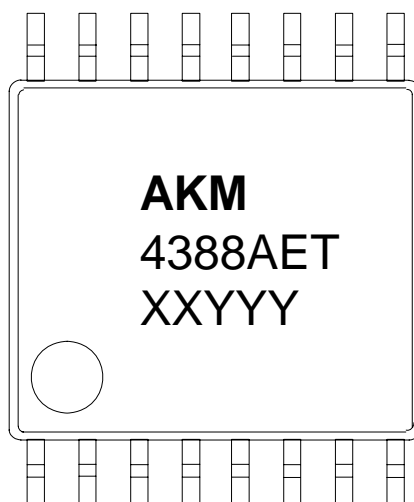

- 1) Pin #1 indication
- 2) Date Code : XXYYYY (5 digits)
 XX: Lot#
 YYY: Date Code
- 3) Marketing Code : 4388AET
- 4) Asahi Kasei Logo

REVISION HISTORY

Date (YY/MM/DD)	Revision	Reason	Page	Contents
08/09/19	00	First Edition		
08/10/17	01	Description Addition	10	<ul style="list-style-type: none"> ■ De-emphasis Filter “In case of double speed and quad speed mode, the digital de-emphasis filter is always off.” was added.
10/09/28	02	Specification Change	16	PACKAGE The package dimension was changed.

IMPORTANT NOTICE

- These products and their specifications are subject to change without notice.
When you consider any use or application of these products, please make inquiries the sales office of Asahi Kasei Microdevices Corporation (AKM) or authorized distributors as to current status of the products.
- Descriptions of external circuits, application circuits, software and other related information contained in this document are provided only to illustrate the operation and application examples of the semiconductor products. You are fully responsible for the incorporation of these external circuits, application circuits, software and other related information in the design of your equipments. AKM assumes no responsibility for any losses incurred by you or third parties arising from the use of these information herein. AKM assumes no liability for infringement of any patent, intellectual property, or other rights in the application or use of such information contained herein.
- Any export of these products, or devices or systems containing them, may require an export license or other official approval under the law and regulations of the country of export pertaining to customs and tariffs, currency exchange, or strategic materials.
- AKM products are neither intended nor authorized for use as critical components^{Note1)} in any safety, life support, or other hazard related device or system^{Note2)}, and AKM assumes no responsibility for such use, except for the use approved with the express written consent by Representative Director of AKM. As used here:
 - Note1) A critical component is one whose failure to function or perform may reasonably be expected to result, whether directly or indirectly, in the loss of the safety or effectiveness of the device or system containing it, and which must therefore meet very high standards of performance and reliability.
 - Note2) A hazard related device or system is one designed or intended for life support or maintenance of safety or for applications in medicine, aerospace, nuclear energy, or other fields, in which its failure to function or perform may reasonably be expected to result in loss of life or in significant injury or damage to person or property.
- It is the responsibility of the buyer or distributor of AKM products, who distributes, disposes of, or otherwise places the product with a third party, to notify such third party in advance of the above content and conditions, and the buyer or distributor agrees to assume any and all responsibility and liability for and hold AKM harmless from any and all claims arising from the use of said product in the absence of such notification.

Looking for pricing, stock, or lifecycle information?

Click below to explore more details on WIN SOURCE:

- ⊖ [View AK4388AETP on WIN SOURCE](#)
- ⊖ [AKM Semiconductor Inc. Information](#)

Optimize Your Supply Chain with WIN SOURCE Solutions

- ✓ Global Sourcing Solution
- ✓ Obsolete Management
- ✓ Cost Control Management
- ✓ Shortage Management
- ✓ Alternative Solution
- ✓ Excess Inventory Management