



THE DATASHEET OF HMC-ALH445



GaAs HEMT MMIC LOW NOISE AMPLIFIER, 18 - 40 GHz

Typical Applications

This HMC-ALH445 is ideal for:

- Wideband Communication Systems
- Point-to-Point Radios
- Point-to-Multi-Point Radios
- Military & Space
- Test Instrumentation

Features

Noise Figure: 3.9 dB @ 28 GHz

Gain: 9 dB

P1dB Output Power: +12 dBm @ 28 GHz

Supply Voltage: +5V @ 45 mA

Die Size: 1.6 x 1.6 x 0.1 mm

Functional Diagram

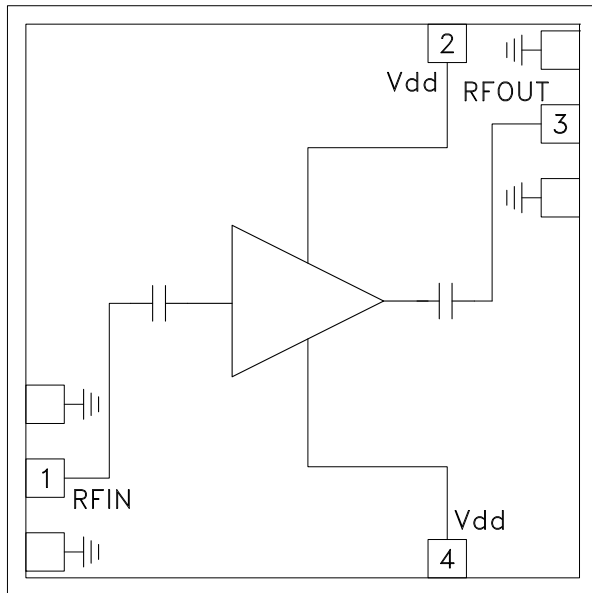

General Description

The HMC-ALH445 is a GaAs MMIC HEMT self-biased, wideband Low Noise Amplifier die which operates between 18 and 40 GHz. The amplifier provides 9 dB of gain, 3.9 dB noise figure at 28 GHz and +12 dBm of output power at 1 dB gain compression while requiring only 45 mA from a single +5V supply. The HMC-ALH445 amplifier is ideal for integration into Multi-Chip-Modules (MCMs) due to its small size.

Electrical Specifications*, $T_A = +25^\circ C$, $V_{dd} = +5V$

Parameter	Min.	Typ.	Max.	Min.	Typ.	Max.	Units
Frequency Range	18 - 28		28 - 40				GHz
Gain	8	9		8	10		dB
Noise Figure		4	5		3.9	4.5	dB
Input Return Loss		10			10		dB
Output Return Loss		15			15		dB
Output Power for 1 dB Compression		12			13		dBm
Supply Current (I _{dd}) (V _{dd} = 5V)		45			45		mA

*Unless otherwise indicated, all measurements are from probed die

GaAs HEMT MMIC LOW NOISE AMPLIFIER, 18 - 40 GHz

Gain vs. Temperature

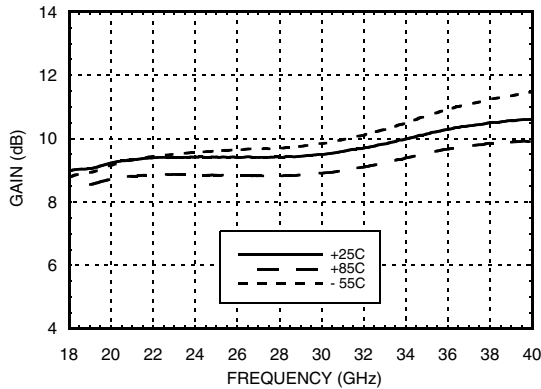

Broadband Gain vs. Return Loss

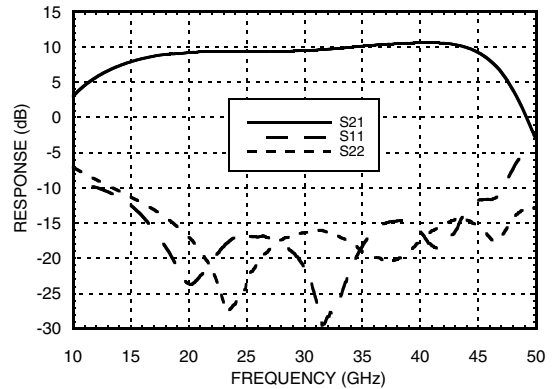

Input Return Loss vs. Frequency

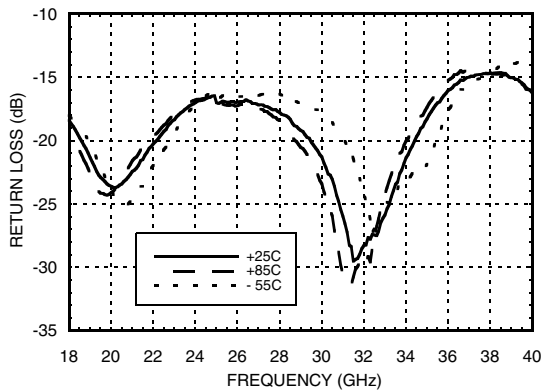

Output Return Loss vs. Frequency

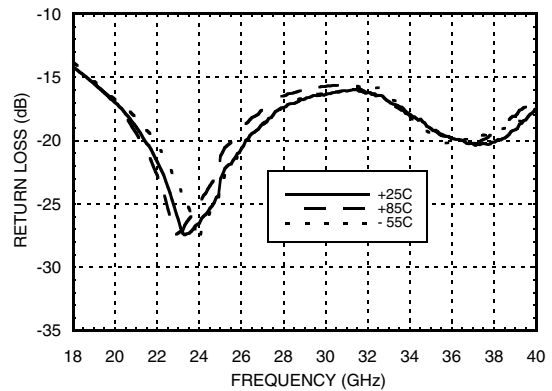

Reverse Isolation vs. Temperature

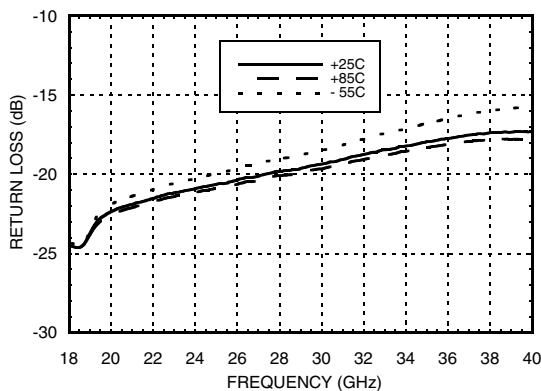

Noise Figure vs. Frequency

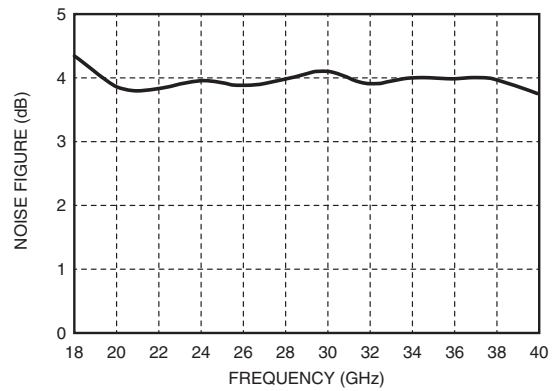

Note: Measured Performance Characteristics (Typical Performance at 25°C) Vd1 = 5V, Id1 = 45 mA

GaAs HEMT MMIC LOW NOISE AMPLIFIER, 18 - 40 GHz

On-Wafer P1dB vs. Frequency

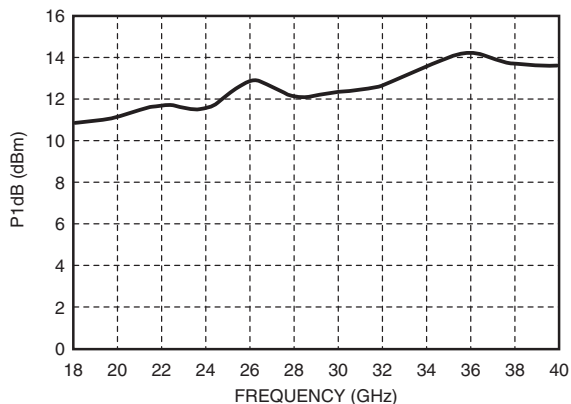

Absolute Maximum Ratings

Drain Bias Voltage	+5.5 Vdc
Drain Bias Current	60 mA
RF Input Power	10 dBm
Thermal Resistance (channel to die bottom)	124 °C/W
Channel Temperature	180 °C
Storage Temperature	-65 to +150 °C
Operating Temperature	-55 to +85 °C



**ELECTROSTATIC SENSITIVE DEVICE
OBSERVE HANDLING PRECAUTIONS**

Outline Drawing

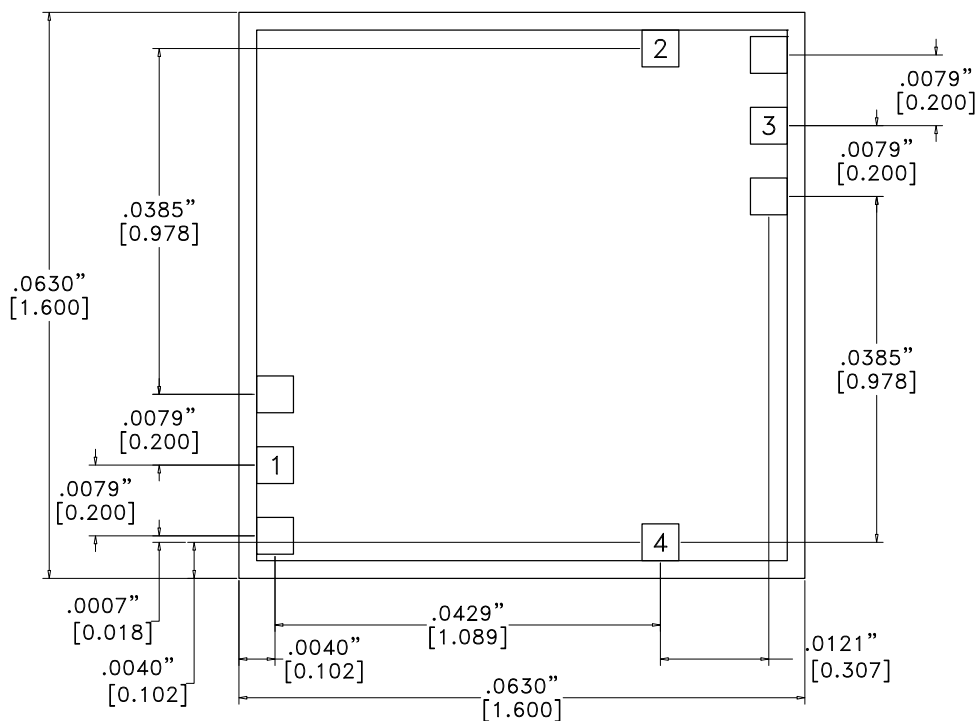

Die Packaging Information [1]

Standard	Alternate
GP-1 (Gel Pack)	[2]

[1] Refer to the "Packaging Information" section for die packaging dimensions.

[2] For alternate packaging information contact Hittite Microwave Corporation.

NOTES:

1. ALL DIMENSIONS ARE IN INCHES [MM].
2. TYPICAL BOND PAD IS .004" SQUARE.
3. BACKSIDE METALLIZATION: GOLD.
4. BACKSIDE METAL IS GROUND.
5. BOND PAD METALLIZATION: GOLD.
6. CONNECTION NOT REQUIRED FOR UNLABELED BOND PADS.
7. OVERALL DIE SIZE ±.002"

GaAs HEMT MMIC LOW NOISE AMPLIFIER, 18 - 40 GHz

Pad Descriptions

Pad Number	Function	Description	Interface Schematic
1	RFIN	This pad is AC coupled and matched to 50 Ohms.	RFIN ○ — —
2, 4	Vdd	Power Supply Voltage for the amplifier. See assembly for required external components.	Vdd ○ — — — —
3	RFOUT	This pad is AC coupled and matched to 50 Ohms.	— — ○ RFOUT
Die bottom	GND	Die bottom must be connected to RF/DC ground.	○ GND —

Assembly Diagram

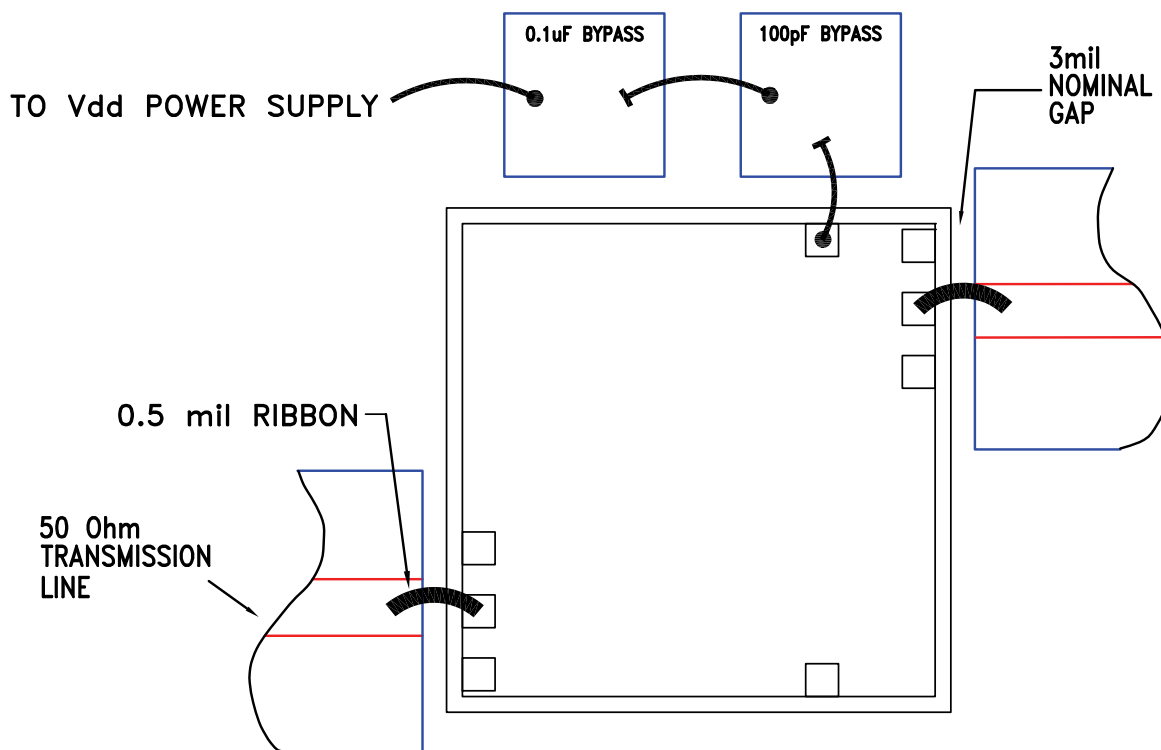

- Note 1: Bypass caps should be 100 pF (approximately) ceramic (single-layer) placed no farther than 30 mils from the amplifier.
- Note 2: Best performance obtained from use of <10 mil (long) by 3 by 0.5mil ribbons on input and output.
- Note 3: Biasable from either side.

GaAs HEMT MMIC LOW NOISE AMPLIFIER, 18 - 40 GHz

Mounting & Bonding Techniques for Millimeterwave GaAs MMICs

The die should be attached directly to the ground plane eutectically or with conductive epoxy (see HMC general Handling, Mounting, Bonding Note).

50 Ohm Microstrip transmission lines on 0.127mm (5 mil) thick alumina thin film substrates are recommended for bringing RF to and from the chip (Figure 1). If 0.254mm (10 mil) thick alumina thin film substrates must be used, the die should be raised 0.150mm (6 mils) so that the surface of the die is coplanar with the surface of the substrate. One way to accomplish this is to attach the 0.102mm (4 mil) thick die to a 0.150mm (6 mil) thick molybdenum heat spreader (moly-tab) which is then attached to the ground plane (Figure 2).

Microstrip substrates should be placed as close to the die as possible in order to minimize bond wire length. Typical die-to-substrate spacing is 0.076mm to 0.152 mm (3 to 6 mils).

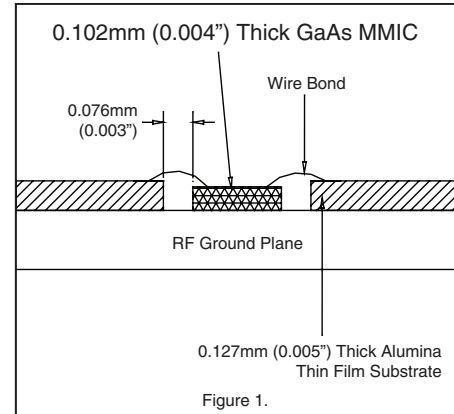

Handling Precautions

Follow these precautions to avoid permanent damage.

Storage: All bare die are placed in either Waffle or Gel based ESD protective containers, and then sealed in an ESD protective bag for shipment. Once the sealed ESD protective bag has been opened, all die should be stored in a dry nitrogen environment.

Cleanliness: Handle the chips in a clean environment. DO NOT attempt to clean the chip using liquid cleaning systems.

Static Sensitivity: Follow ESD precautions to protect against ESD strikes.

Transients: Suppress instrument and bias supply transients while bias is applied. Use shielded signal and bias cables to minimize inductive pick-up.

General Handling: Handle the chip along the edges with a vacuum collet or with a sharp pair of bent tweezers. The surface of the chip has fragile air bridges and should not be touched with vacuum collet, tweezers, or fingers.

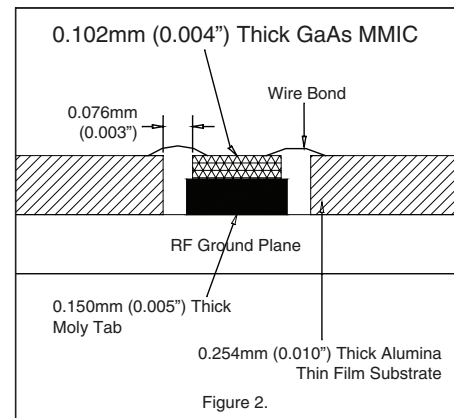

Mounting

The chip is back-metallized and can be die mounted with AuSn eutectic preforms or with electrically conductive epoxy. The mounting surface should be clean and flat.

Eutectic Die Attach: A 80/20 gold tin preform is recommended with a work surface temperature of 255 °C and a tool temperature of 265 °C. When hot 90/10 nitrogen/hydrogen gas is applied, tool tip temperature should be 290 °C. DO NOT expose the chip to a temperature greater than 320 °C for more than 20 seconds. No more than 3 seconds of scrubbing should be required for attachment.

Epoxy Die Attach: Apply a minimum amount of epoxy to the mounting surface so that a thin epoxy fillet is observed around the perimeter of the chip once it is placed into position. Cure epoxy per the manufacturer's schedule.

Wire Bonding

RF bonds made with 0.003" x 0.0005" ribbon are recommended. These bonds should be thermosonically bonded with a force of 40-60 grams. DC bonds of 0.001" (0.025 mm) diameter, thermosonically bonded, are recommended. Ball bonds should be made with a force of 40-50 grams and wedge bonds at 18-22 grams. All bonds should be made with a nominal stage temperature of 150 °C. A minimum amount of ultrasonic energy should be applied to achieve reliable bonds. All bonds should be as short as possible, less than 12 mils (0.31 mm).

**GaAs HEMT MMIC LOW NOISE
AMPLIFIER, 18 - 40 GHz****Notes:**

Looking for pricing, stock, or lifecycle information?

Click below to explore more details on WIN SOURCE:

- ⊖ [View HMC-ALH445 on WIN SOURCE](#)
- ⊖ [Analog Devices Inc. Information](#)

Optimize Your Supply Chain with WIN SOURCE Solutions

- ✓ Global Sourcing Solution
- ✓ Obsolete Management
- ✓ Cost Control Management
- ✓ Shortage Management
- ✓ Alternative Solution
- ✓ Excess Inventory Management