

Bluetooth® Dual-Mode Module

Features

- Bluetooth Classic (BR/EDR) and Low Energy (LE)
- Certified to FCC, ISED, MIC, KCC, SRRC and NCC radio regulations
- Radio Equipment Directive (RED) Assessed Radio module
- Bluetooth 5.0 certified
- Transparent UART mode for seamless serial data over UART interface
- Easy to configure with User Interface (UI) tool, a Windows®-based utility or directly by MCUs
- Firmware can be upgraded in the field over UART (Flash version only)
- Integral chip antenna (BM78SPPS5MC2/NC2) or external antenna (BM78SPP05MC2/NC2)
- Integrated crystal, internal voltage regulator, and matching circuitry
- Configurable I/O pins for control and status
- Supports Apple® iPod® Accessory Protocol (iAP2), (only BM78SPPx5MC2)
- Supports Bluetooth Low Energy secure connections
- Supports Bluetooth Low Energy data packet length extension
- Small and compact surface mount module
- Castellated surface mount pads for easy and reliable host PCB mounting
- Ideal for portable battery-operated devices
- One LED driver with 16 step brightness control

RF/Analog

- Frequency spectrum: 2.402 GHz to 2.480 GHz
- Receive Sensitivity: -90 dBm (BR/EDR), -92 dBm (LE)
- Class 2 output power (+1.5 dBm typical)

Data Throughput

Data throughput at 1 Mbps UART baud rate:

- BR/EDR: up to 32 Kbytes/s
- LE: up to 7 Kbytes/s

Data throughput at 115200 bps UART baud rate:

- BR/EDR: up to 10 Kbytes/s
- LE: up to 6 Kbytes/s

FIGURE 1: BM78 MODULE

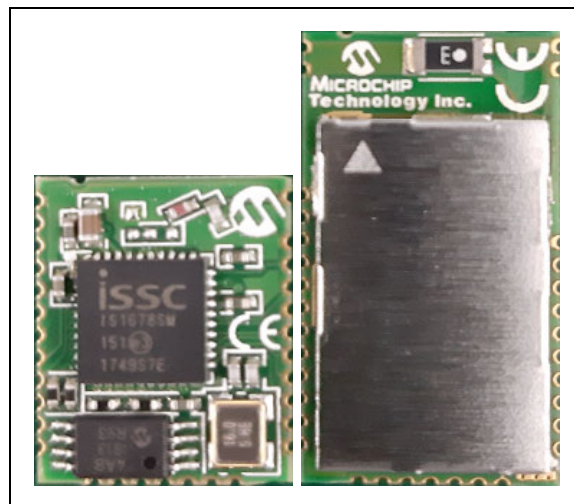

MAC/Baseband/Higher Layer

- Secure AES128 encryption
- Bluetooth 3.0: GAP, SPP, SDP, RFCOMM, and L2CAP
- Bluetooth profiles: GAP, GATT, ATT, SMP, and L2CAP

Operating Conditions

- Operating voltage range: 3.3V to 4.2V
- Operating temperature: -20°C to +70°C

Applications

- Internet of Things (IoT)
- Secure payment
- Home and security
- Health and fitness
- Industrial and data logger
- LED lighting (16 configurations)

BM78

General Description

The BM78 module is a fully-certified Bluetooth module for customers to easily add dual-mode Bluetooth wireless capability to their products. The BM78 module is built around Microchip's IS1678 Bluetooth dual-mode SoC, and it is available in ROM-based (BM78SPPx5NC2) and Flash-based (BM78SPPx5MC2) versions. Refer to [9.0 "Ordering Information"](#) for additional information on the BM78 Stock Keeping Units (SKUs).

The BM78 module bridges the customer products to smart phones or tablets for convenient data transfer, control, access to cloud applications and delivering the local connectivity for IoT. The BM78 module supports GAP, SDP, SPP, and GATT profiles. Data transfer is achieved through the Bluetooth link by sending or receiving data through Transparent UART mode, making it easy to integrate with any microprocessor or microcontroller with the UART interface. It also enables an easy configuration by using a UI tool, a Windows-based utility, or directly through UART by MCUs.

Table of Contents

1.0 System Overview	5
2.0 Application Information	11
3.0 Operating Modes	25
4.0 Electrical Characteristics	29
5.0 Radio Characteristics	33
6.0 Physical Dimensions	35
7.0 Reflow Profile Module	41
8.0 Module Placement Guidelines	43
9.0 Ordering Information	47
Appendix A: Certification Notices	49
Appendix B: Revision History	55

TO OUR VALUED CUSTOMERS

It is our intention to provide our valued customers with the best documentation possible to ensure successful use of your Microchip products. To this end, we will continue to improve our publications to better suit your needs. Our publications will be refined and enhanced as new volumes and updates are introduced.

If you have any questions or comments regarding this publication, please contact the Marketing Communications Department via E-mail at docerrors@microchip.com or fax the **Reader Response Form** in the back of this data sheet to (480) 792-4150. We welcome your feedback.

Most Current Data Sheet

To obtain the most up-to-date version of this data sheet, please register at our Worldwide Web site at:

<http://www.microchip.com>

You can determine the version of a data sheet by examining its literature number found on the bottom outside corner of any page. The last character of the literature number is the version number, (e.g., DS30000000A is version A of document DS30000000).

Errata

An errata sheet, describing minor operational differences from the data sheet and recommended workarounds, may exist for current devices. As device/documentation issues become known to us, we will publish an errata sheet. The errata will specify the revision of silicon and revision of document to which it applies.

To determine if an errata sheet exists for a particular device, please check with one of the following:

- Microchip's Worldwide Web site; <http://www.microchip.com>
- Your local Microchip sales office (see last page)

When contacting a sales office, please specify which device, revision of silicon and data sheet (include literature number) you are using.

Customer Notification System

Register on our web site at www.microchip.com to receive the most current information on all of our products.

BM78

NOTES:

1.0 SYSTEM OVERVIEW

The BM78 module is a fully-certified, embedded 2.4 GHz Bluetooth (BR/EDR/LE) wireless module. It includes an on-board Bluetooth stack, power management subsystem, 2.4 GHz transceiver, and RF power amplifier. Customers can embed Bluetooth functionality into any application using the BM78 module.

The BM78 module enables rapid product development and faster time to market, and it is designed to provide integrators with the following features:

- Simple integration and programming
- Reduced development time
- Superior wireless module with low-cost system
- Interoperability with Bluetooth host
- Wide range of applications

The BM78SPPS5MC2/NC2 is a complete and fully regulatory certified module with an integral ceramic chip antenna and RF shield. The BM78SPP05MC2/NC2 is a low-cost alternative with RF-out pin (for external antenna) and no RF shield. The integrator is responsible for the antenna, antenna matching, and regulatory certifications.

The BM78 module is a small, compact, and surface-mounted module with castellated pads for easy and reliable host PCB mounting. It is compatible with standard pick-and-place equipment and can independently maintain a low-power wireless connection. Low-power usage and flexible power management maximize the lifetime of the BM78 module in battery operated devices. A wide operating temperature range enable its applications in indoor and outdoor environments. [Figure 1-1](#) illustrates the internal block diagram of the BM78 module.

FIGURE 1-1: INTERNAL BLOCK DIAGRAM OF BM78 MODULE

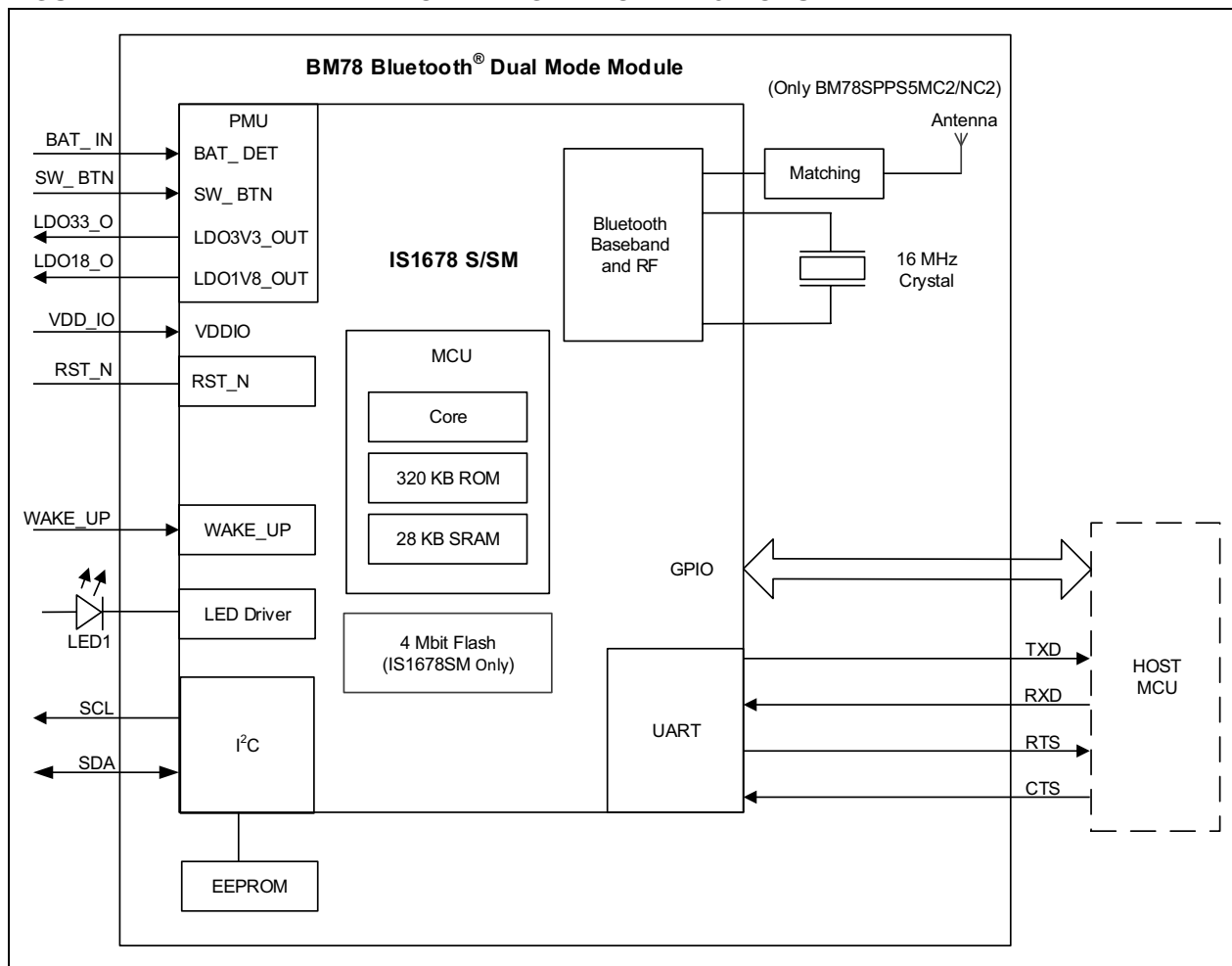

BM78

Table 1-1 provides various pins of the BM78SPPx5MC2/NC2 module.

TABLE 1-1: PIN DESCRIPTION

S5 Pin	05 Pin	Symbol	Type	Description
1	—	GND	Power	Ground reference
2	—	GND	Power	Ground reference
3	1	GND	Power	Ground reference
4	2	BAT_IN	Power	Battery input (3.3V to 4.2V) Main positive supply input Connect to 10 μ F (X5R/X7R) capacitor
5	3	SW_BTN	DI	Software Power Button H: Power On L: Power Off
6	4	LDO33_O	Power	Internal 3.3V LDO output, cannot source more than 50 mA
7	5	VDD_IO	Power	I/O positive supply input. Internal use only, do not connect to other devices
8	6	LDO18_O	Power	Internal 1.8V LDO output. Internal use only, do not connect to other devices
9	7	WAKE_UP	DI	Wake up from Sleep mode (active-low) (internal pull up)
10	8	PMULDO_O	Power	Power Management Unit (PMU) output. Internal use only, do not connect to other devices
11	9	P0_4	DO	Status Indication pin, refer to Table 2-4
12	10	P1_5	DO	Status Indication pin, refer to Table 2-4
13	11	P1_2/SCL	DO	I ² C SCL
14	12	P1_3/SDA	DIO	I ² C SDA
15	13	P1_7	DIO	Configurable control or Indication pin or UART CTS (input)
16	14	P0_5	DIO	Configurable control or Indication pin
17	15	P0_0	DIO	Configurable control or Indication pin or UART RTS (output)
18	16	P2_0	DI	System configuration pin along with P2_4 and EAN pins, used to set the BM78 module in any one of the following three modes: <ul style="list-style-type: none"> • Application mode (for normal operation), • Test mode (to change EEPROM values), and • Write Flash mode (to download the firmware into the module), refer to Table 2-1
19	17	P2_4	DI	System configuration pin along with P2_0 and EAN pins, used to set the BM78 module in any one of the following three modes: <ul style="list-style-type: none"> • Application mode (for normal operation), • Test mode (to change EEPROM values), and • Write Flash mode (to download the firmware into the module), refer to Table 2-1

Legend: A = Analog D = Digital I = Input O = Output

TABLE 1-1: PIN DESCRIPTION (CONTINUED)

S5 Pin	05 Pin	Symbol	Type	Description
20	18	EAN	DI	External address-bus negative System configuration pin along with P2_0 and P2_4 pins used to set the module in any of the three modes: <ul style="list-style-type: none"> • Application mode (for normal operation), • Test mode (to change EEPROM values), and • Write Flash mode (to download the firmware into the module), refer to Table 2-1 ROM: Must be pulled high to VDD_IO FLASH: Must be pulled down with 4.7 kOhm to Ground
21	19	RST_N	DI	Module Reset (active-low) (internal pull up) Apply a pulse of at least 63 ns
22	20	HCI_RXD	DI	UART data input
23	21	HCI_TXD	DO	UART data output
24	22	P3_1	DIO	Configurable control or Indication pin (Internally pulled-up, if configured as an input)
25	23	P3_2	DIO	Configurable control or Indication pin (Internally pulled-up, if configured as an input)
26	24	P3_3	DIO	Configurable control or Indication pin (Internally pulled-up, if configured as an input)
27	25	P3_4	DIO	Configurable control or Indication pin (Internally pulled-up, if configured as an input)
28	26	P3_6	DIO	Do not connect
29	27	P3_7	DIO	Configurable control or Indication pin (Internally pulled-up, if configured as an input)
30	28	LED1	DO	LED driver, connect to LDO33_0
31	29	GND	Power	Ground reference
—	30	BT_RF	AIO	External antenna connection (50 Ohm)
32	—	GND	Power	Ground reference
33	—	GND	Power	Ground reference

Legend: A = Analog D = Digital I = Input O = Output

BM78

Figure 1-2 and Figure 1-3 illustrate the pin diagrams of the BM78SPPS5MC2/NC2 and BM78SPP05MC2/NC2 modules.

FIGURE 1-2: BM78SPPS5MC2/NC2 PIN DIAGRAM

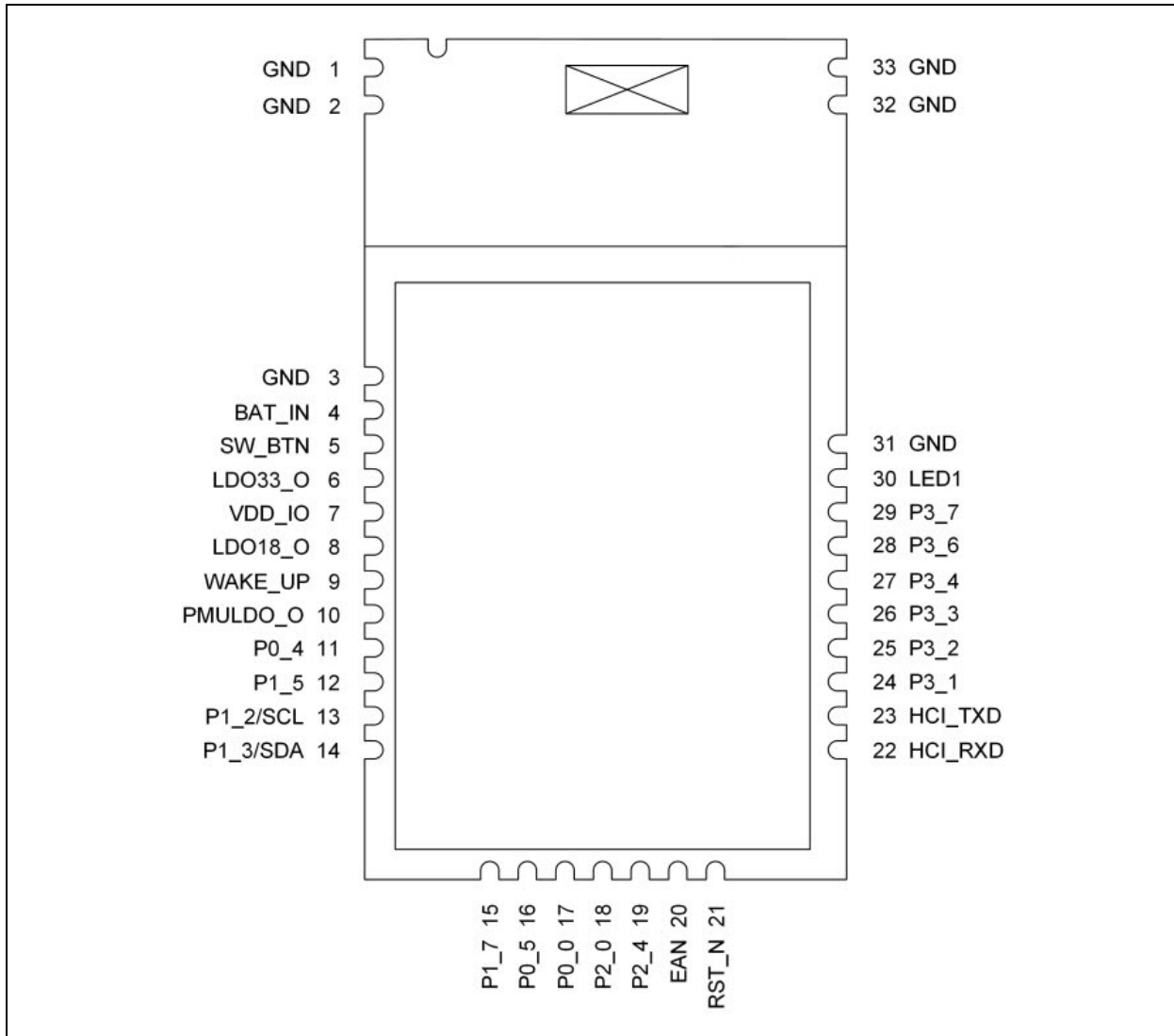
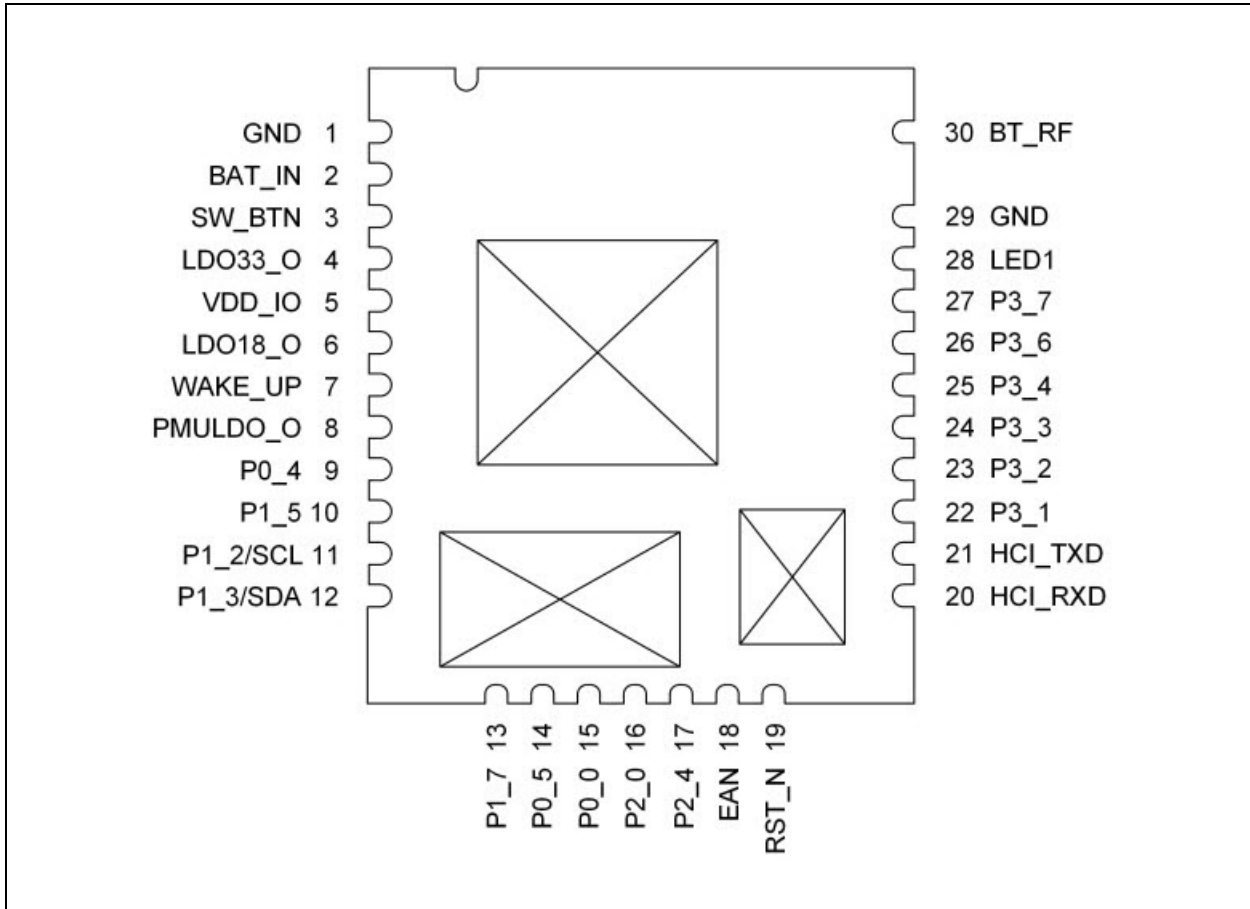

FIGURE 1-3: BM78SPP05MC2/NC2 PIN DIAGRAM



BM78

NOTES:

2.0 APPLICATION INFORMATION

Each of these pins have internal pull up and allow configuration settings and firmware update from the UART. [Table 2-1](#) provides the system configuration settings.

2.1 System Configuration

The system configuration I/O pins P2_0, P2_4 and EAN are used to set the configuration and firmware programming modes.

TABLE 2-1: SYSTEM CONFIGURATION SETTINGS

Module	P2_0	P2_4	EAN	Operational Mode
BM78SPPx5NC2 (ROM Variant)	Low	High	High	Test mode (Write EEPROM)
	High	High	High	APP mode (Normal operation)
BM78SPPx5MC2 (Flash Variant)	Low	Low	High	Write Flash
	Low	High	Low	Test mode (Write EEPROM)
	High	High	Low	APP mode (Normal operation)

2.2 Control and Indication I/O Pins

The I/O pins, P0_0, P0_5, P1_7, P3_1, P3_2, P3_3, P3_4, and P3_7 are configurable control and indication pins. The control signals are input to the BM78 module

and the indication signals are output from the BM78 module. [Table 2-2](#) provides default I/O pin configuration details.

TABLE 2-2: CONTROL AND INDICATION I/O PIN ASSIGNMENTS

PIN Symbol	Default Configuration
P0_0	UART_RTS ^(1,2)
P0_5	N/C
P1_7	UART_CTS ^(1,2)
P3_1	INQUIRY CONTROL
P3_2	LINK_DROP_CONTROL (DISCONNECT)
P3_3	UART_RX_IND
P3_4	PAIRING_KEY
P3_7	LOW_BATTERY_IND

Note 1: The RTS pin can only be assigned to P0_0 and the CTS pin can only be assigned to P1_7.

2: The RTS and CTS pins can be configured as GPIOs, if flow control is disabled.

[Table 2-3](#) provides the configurable functions and descriptions of I/O pins.

TABLE 2-3: CONFIGURABLE FUNCTIONS AND DESCRIPTIONS

Function Name	Description
Low battery indication	This function, when assigned to a pin, ensures the output goes low when the battery level is below a specified level. The UI tool can set the battery level.
RSSI indication	When assigned to a pin, this function can be used to indicate the quality of the link based on the Received Signal Strength Indicator (RSSI) level. If the RSSI level is lower than the specified values, then the RSSI indication pin goes low.
Link drop control	When assigned to a pin, this function can be used to force the module to drop the current Bluetooth Low Energy (BLE) link with a peer device. Pulling the Link Drop pin low will force the disconnect. The pin needs to be pulled low for at least 10 ms.

TABLE 2-3: CONFIGURABLE FUNCTIONS AND DESCRIPTIONS

Function Name	Description
UART RX indication	When assigned to a pin, this function enables communication with the UART when the module is in Low-Power mode. When not in Low-Power mode, the module runs on a 16 MHz clock. If the user intends to provide data or commands through UART in the Low-Power mode, then the UART_RX_IND pin needs to be pulled low and the user has to wait at least 5 ms before sending the data. Pulling the UART_RX_IND pin low allows the module to operate the 16 MHz clock and to enable UART.
Pairing key	When assigned to a pin, this function can be used to force the module to enter Standby mode. The pin needs to be pulled down for at least 160 ms.
Inquiry control	When assigned to a pin, this function forces the module to enter Inquiry mode (Bluetooth Classic). The pin must be pulled low for at least 240 ms for the device to enter Inquiry mode.
Profile_IND	When assigned to a pin, this function can be used to indicate whether current connection is in Basic Data Rate (BDR)/Enhanced Data Rate (EDR) (Bluetooth Classic), or in BLE. If the Profile_IND pin is high, then the current connection is BDR/EDR connection. If low, then the current connection is a BLE connection. This pin is valid only for Link state.

2.3 Status Indication I/O Pins

The I/O pins, P1_5 and P0_4, are status indicator pins: STATUS_IND_1 and STATUS_IND_2. Both the pins provide status indication to host MCUs. [Table 2-4](#) provides status indication of the P1_5 and P0_4 pins.

TABLE 2-4: STATUS INDICATION

P1_5/STATUS_IND_1	P0_4/STATUS_IND_2	Indication
H	H	Power-on (default setting) and Deep-sleep state. HH status should be stable for at least 500 ms
H	L	Access state
L	H	Link state (UART data transmitting)
L	L	Link state (no UART data transmitted)

Legend: L = Low H = High

2.4 Power Tree

Figure 2-1 illustrates the power tree diagram of the BM78 module.

FIGURE 2-1: POWER TREE DIAGRAM

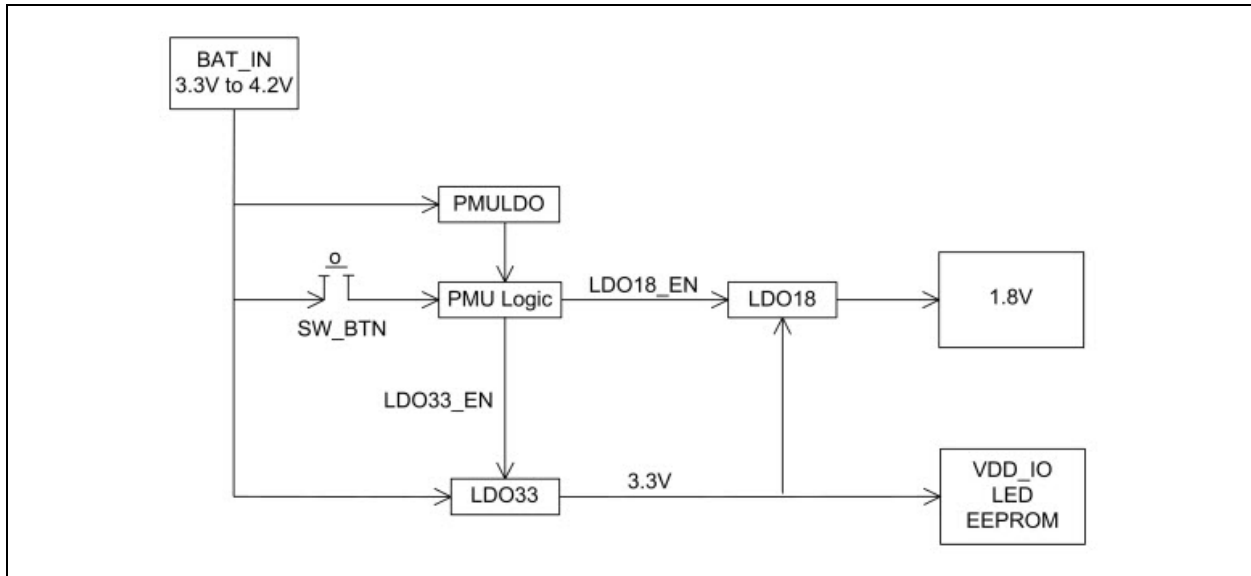

BM78

2.5 Software Power Button (SW_BTN)

The Software power button (SW_BTN) input pin powers the BM78 module ON (high) or OFF (low) into the S4 mode. The S4 mode is the Deep-sleep mode and

the S2 mode is the Sleep mode. The S4 mode can only be triggered by the SW_BTN pin, and the power consumption is lower in the S4 mode.

Figure 2-2 through Figure 2-4 illustrates the waveforms of the BM78 module in the high and low status, that is access and link status.

FIGURE 2-2: SW_BTN TIMING (HIGH) AT APPLICATION MODE

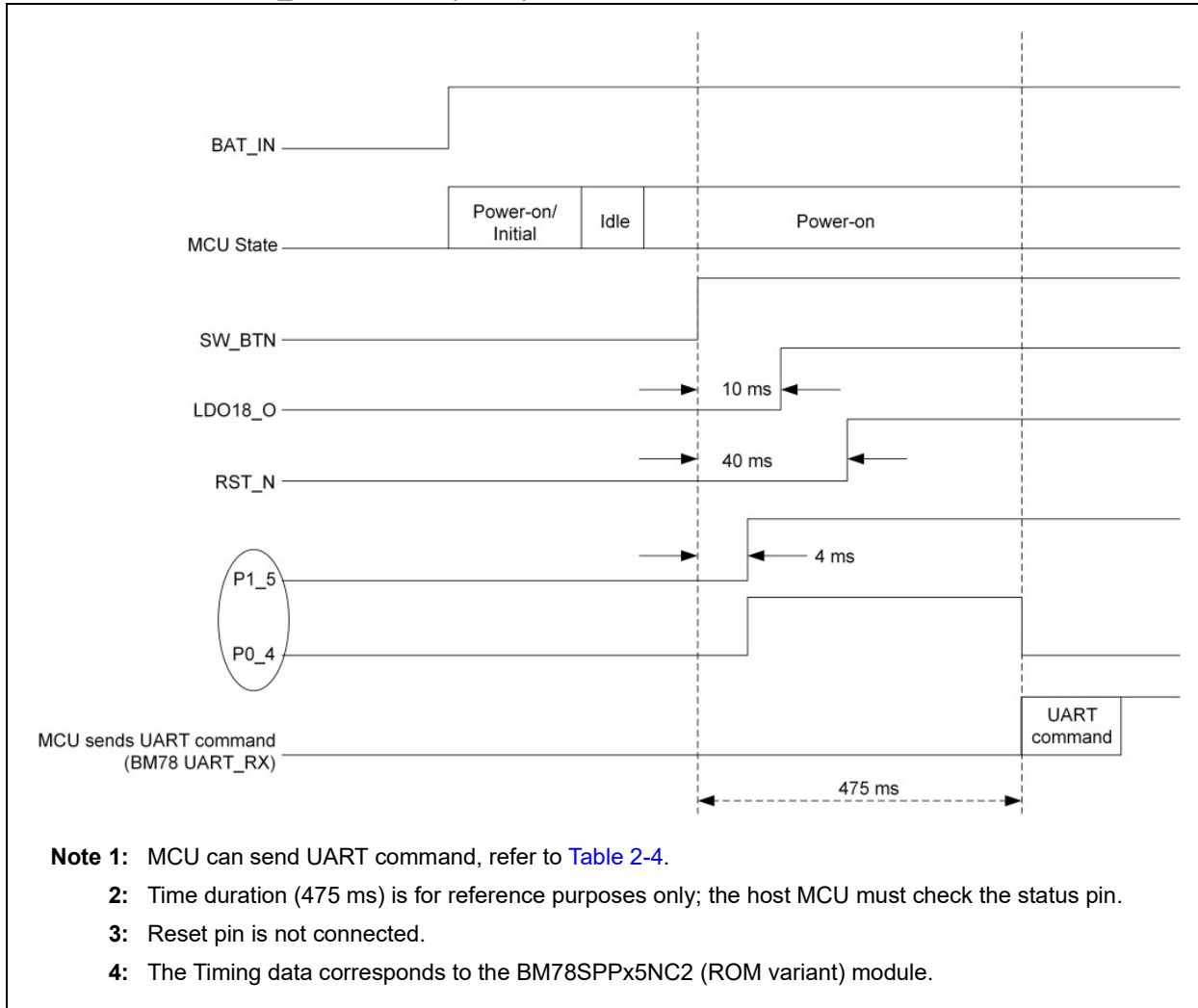

FIGURE 2-3: SW_BTN TIMING AT ACCESS STATES

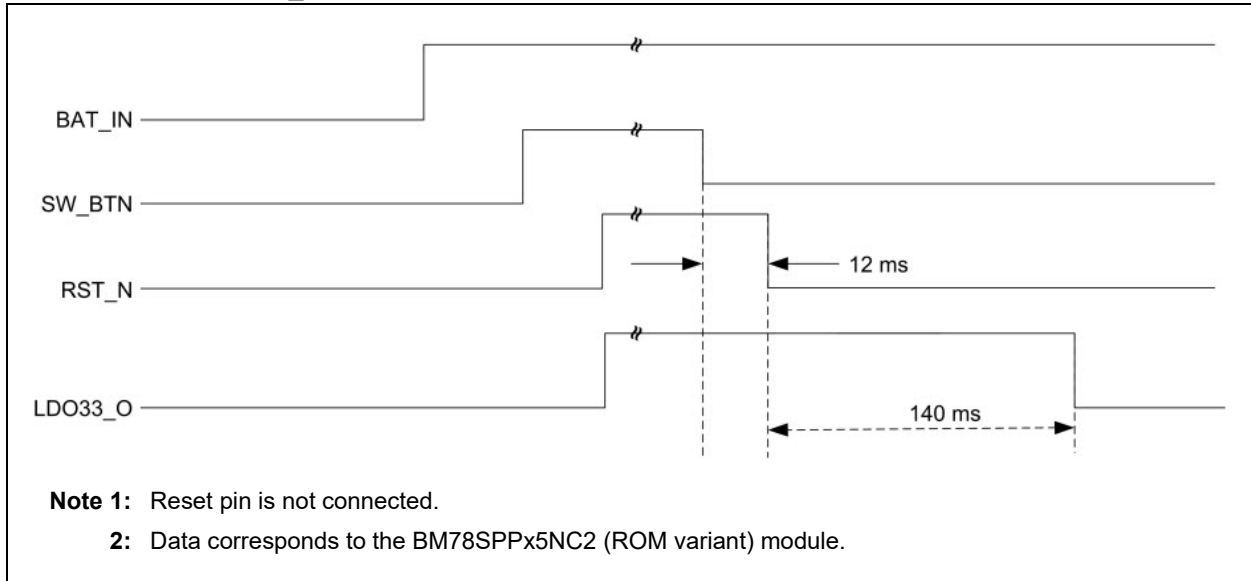
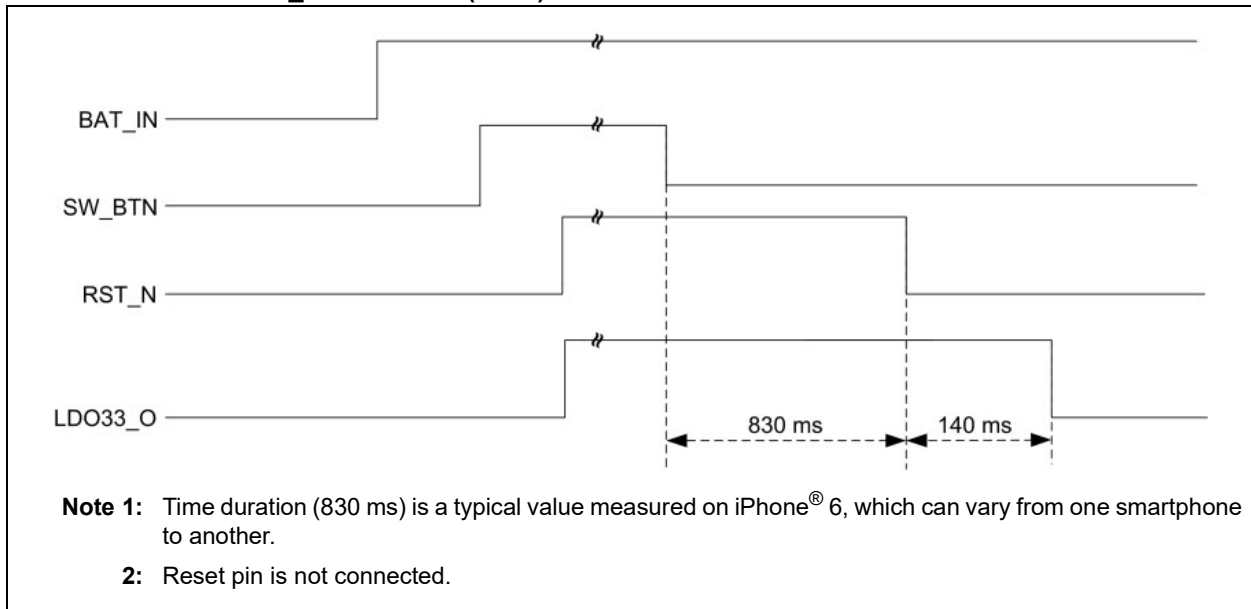

FIGURE 2-4: SW_BTN TIMING (LOW) AT LINK STATES



BM78

2.6 WAKE-UP

The WAKE_UP input pin wakes the BM78 module from Sleep mode. The WAKE_UP pin is active-low and puts the module from Sleep mode (S2) to Standby mode. [Figure 2-5](#) illustrates the timing diagram of the BM78 module in the Wake-Up mode.

FIGURE 2-5: WAKE-UP TIME

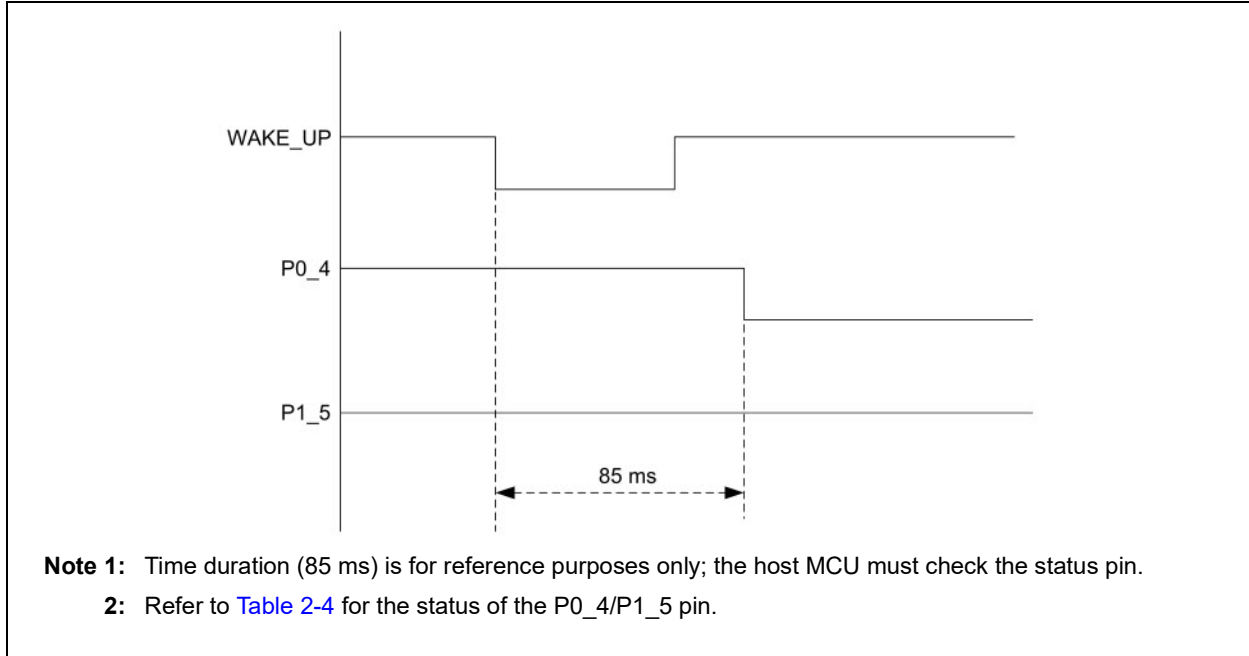

- Note 1:** Time duration (85 ms) is for reference purposes only; the host MCU must check the status pin.
- 2:** Refer to [Table 2-4](#) for the status of the P0_4/P1_5 pin.

2.7 External Reset

The BM78 module provides a Watchdog Timer (WDT) to reset the chip. It has an integrated Power-on Reset (POR) circuit that resets all circuits to a known Power-on state. This action can also be driven by an external Reset signal which is used to externally control

the device by forcing it into a POR state. The RST_N signal input is active-low and connection is not required in most of the applications.

Figure 2-6 illustrates the timing diagram of the BM78 module when it is in the Reset (RST_N is set to active-low) state.

FIGURE 2-6: TIMING WAVEFORMS ON RESET

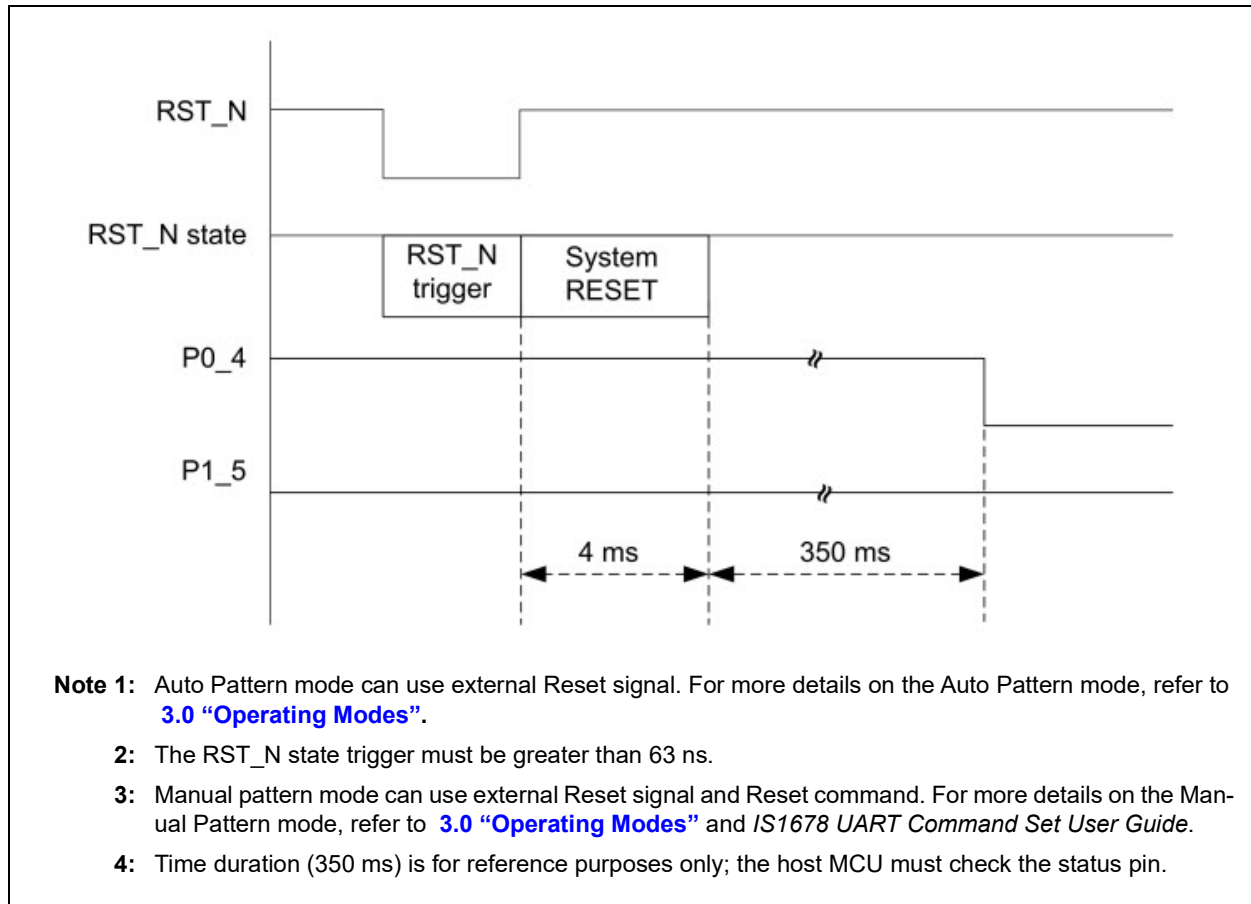

- Note 1:** Auto Pattern mode can use external Reset signal. For more details on the Auto Pattern mode, refer to [3.0 “Operating Modes”](#).
- 2:** The RST_N state trigger must be greater than 63 ns.
- 3:** Manual pattern mode can use external Reset signal and Reset command. For more details on the Manual Pattern mode, refer to [3.0 “Operating Modes”](#) and *IS1678 UART Command Set User Guide*.
- 4:** Time duration (350 ms) is for reference purposes only; the host MCU must check the status pin.

BM78

2.8 LED Driver

The BM78 module has a dedicated LED driver and the LED (LED1) can be connected directly with the BM78 module using this driver, see [Figure 2-7](#).

The maximum current sourcing for the LED is 5 mA, and it provides 16 options (steps) to trim the brightness. The LED brightness can be configured using the UI tool, a Windows-based utility.

The following are status indications of the LED. Each indication is a configurable flashing sequence:

- Standby
- Link Back
- Low Battery
- Inquiry
- Link

FIGURE 2-7: LED DRIVER

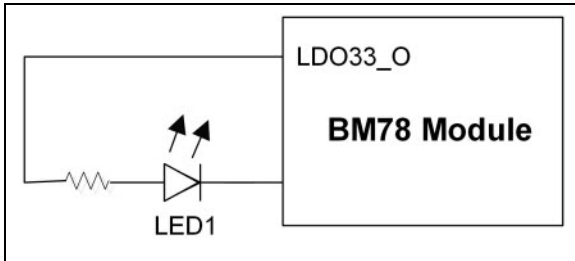

2.9 Host MCU Interface over UART

Figure 2-8 illustrates the UART interface with host MCU and power scheme using 3.3V to the VDD. Battery power is applied to the BAT_IN pin. From the LDO33_O pin, voltage can be routed to the VDD_IO

pin and external circuitry including the MCU. This power scheme ensures that the BM78 module and MCU I/O voltages are compatible.

Note: The internal 3.3V LDO current source must not exceed maximum value of 50 mA.

FIGURE 2-8: POWER AND MCU INTERFACE EXAMPLE FOR BM78 MODULE

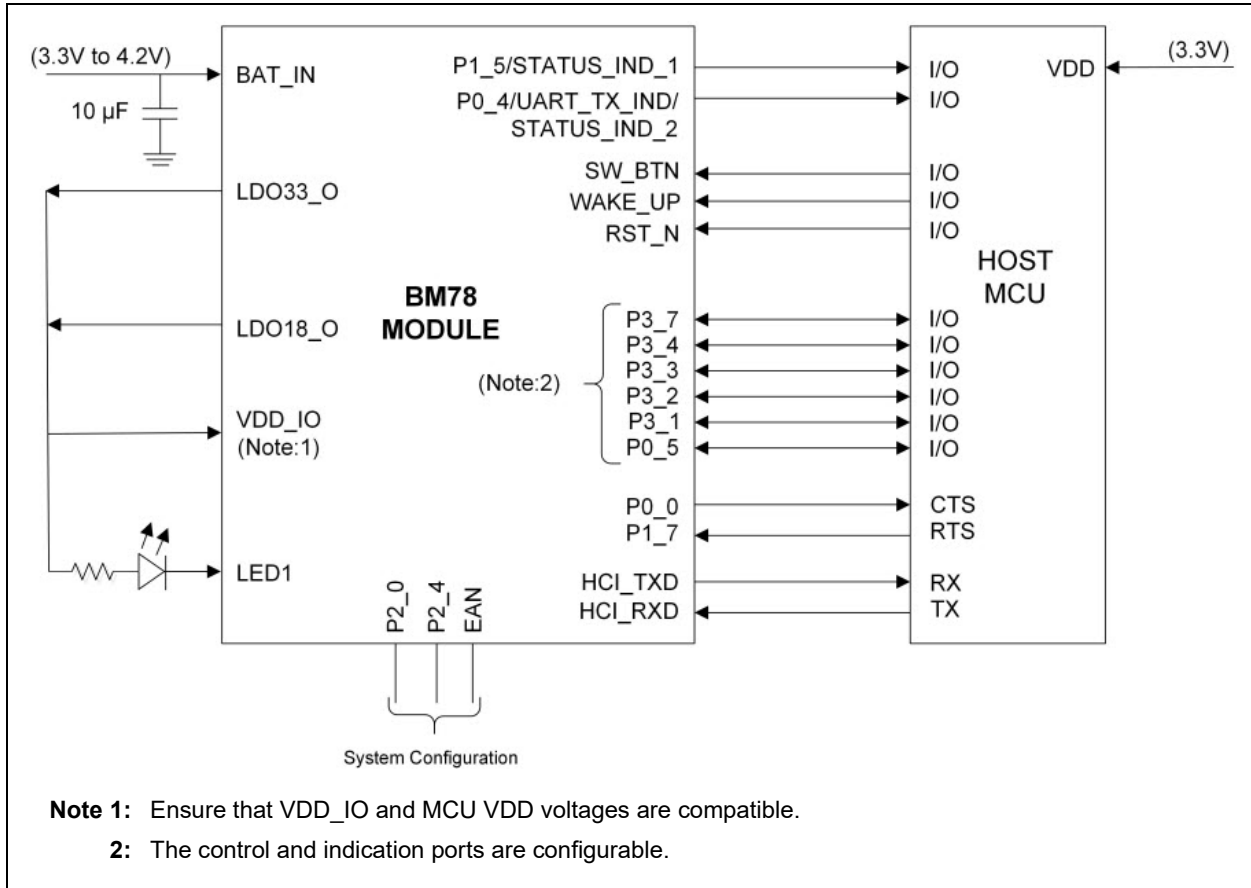

FIGURE 2-10: BM78SPP05MC2/NC2 REFERENCE CIRCUIT

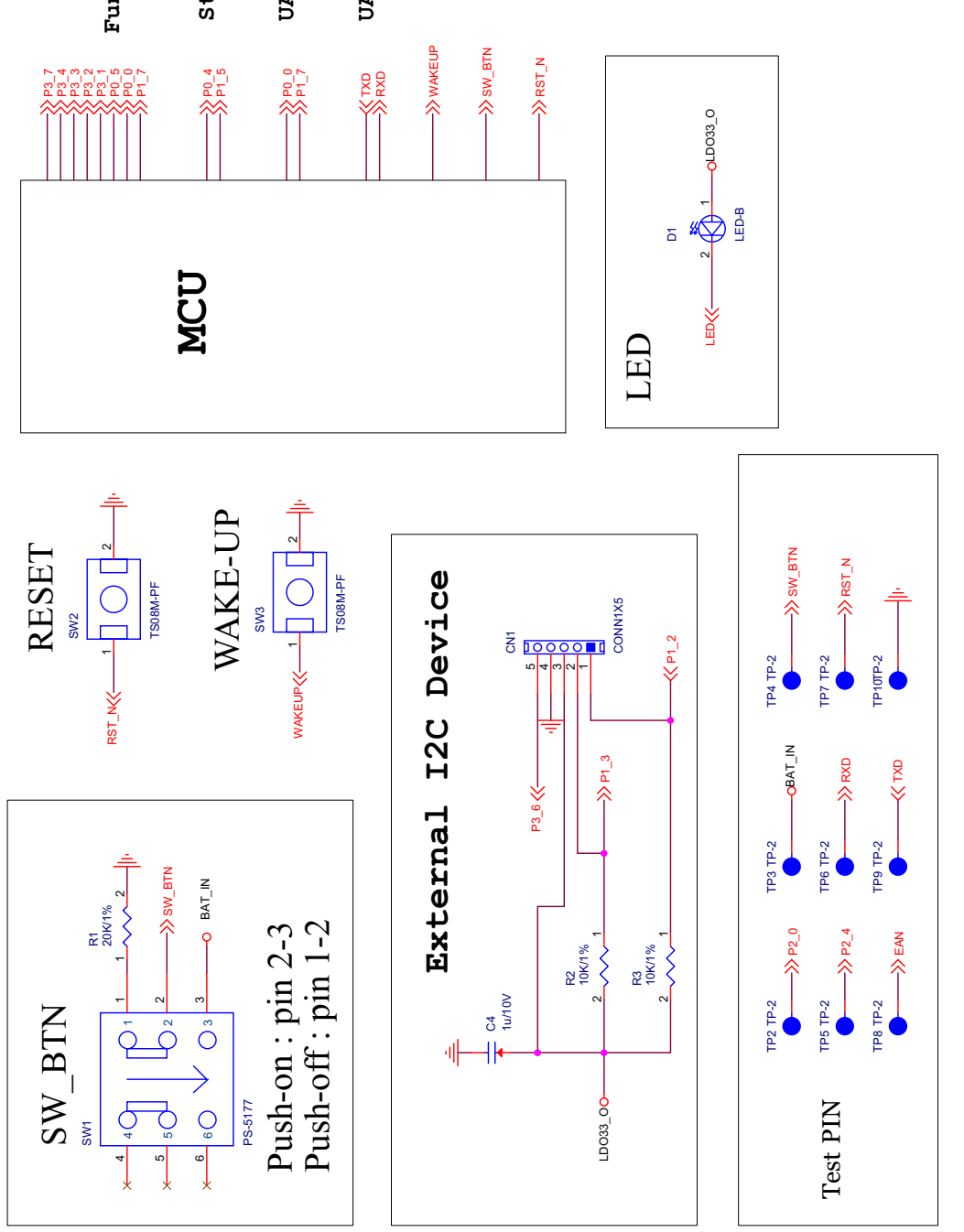

FIGURE 2-11: BM78SPPS5MC2/NC2 REFERENCE CIRCUIT

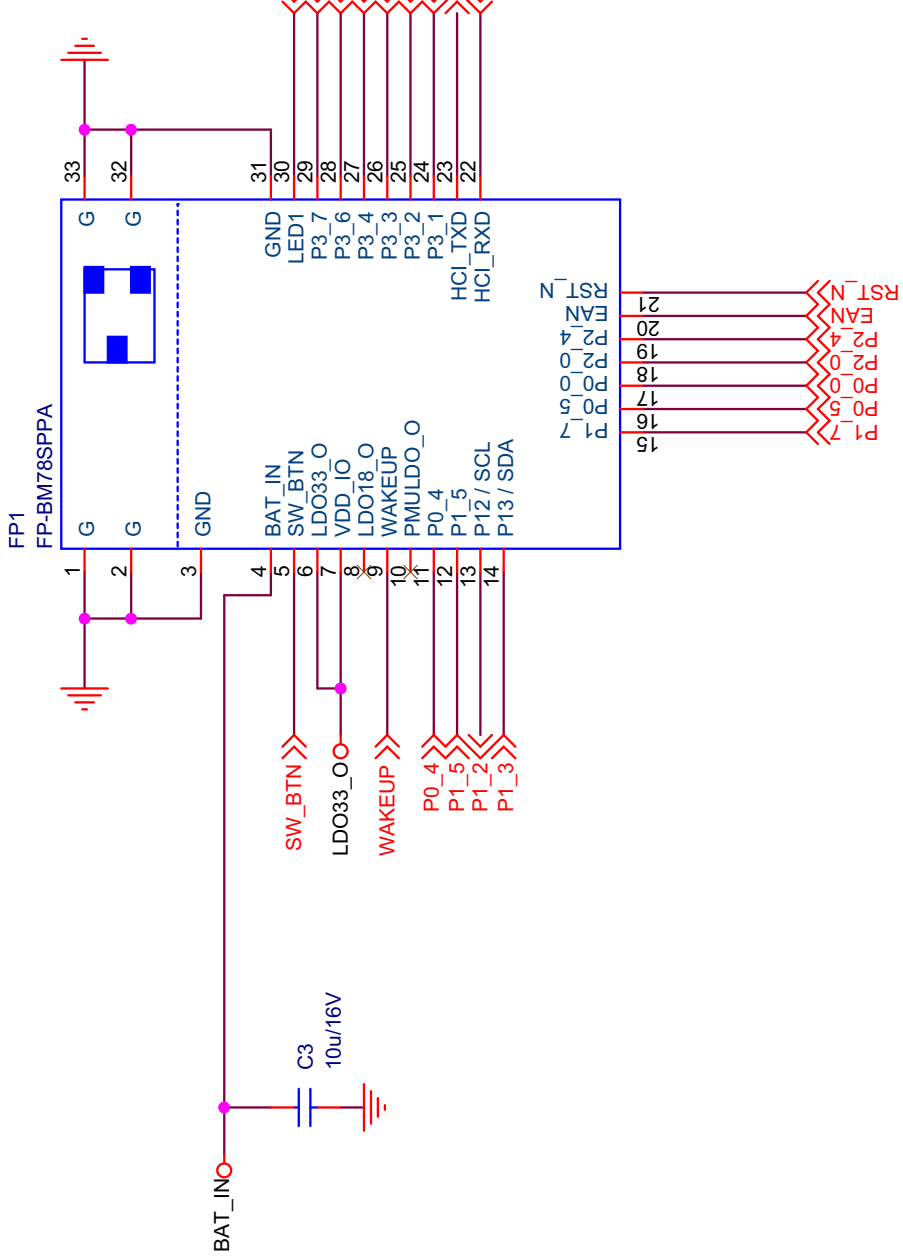
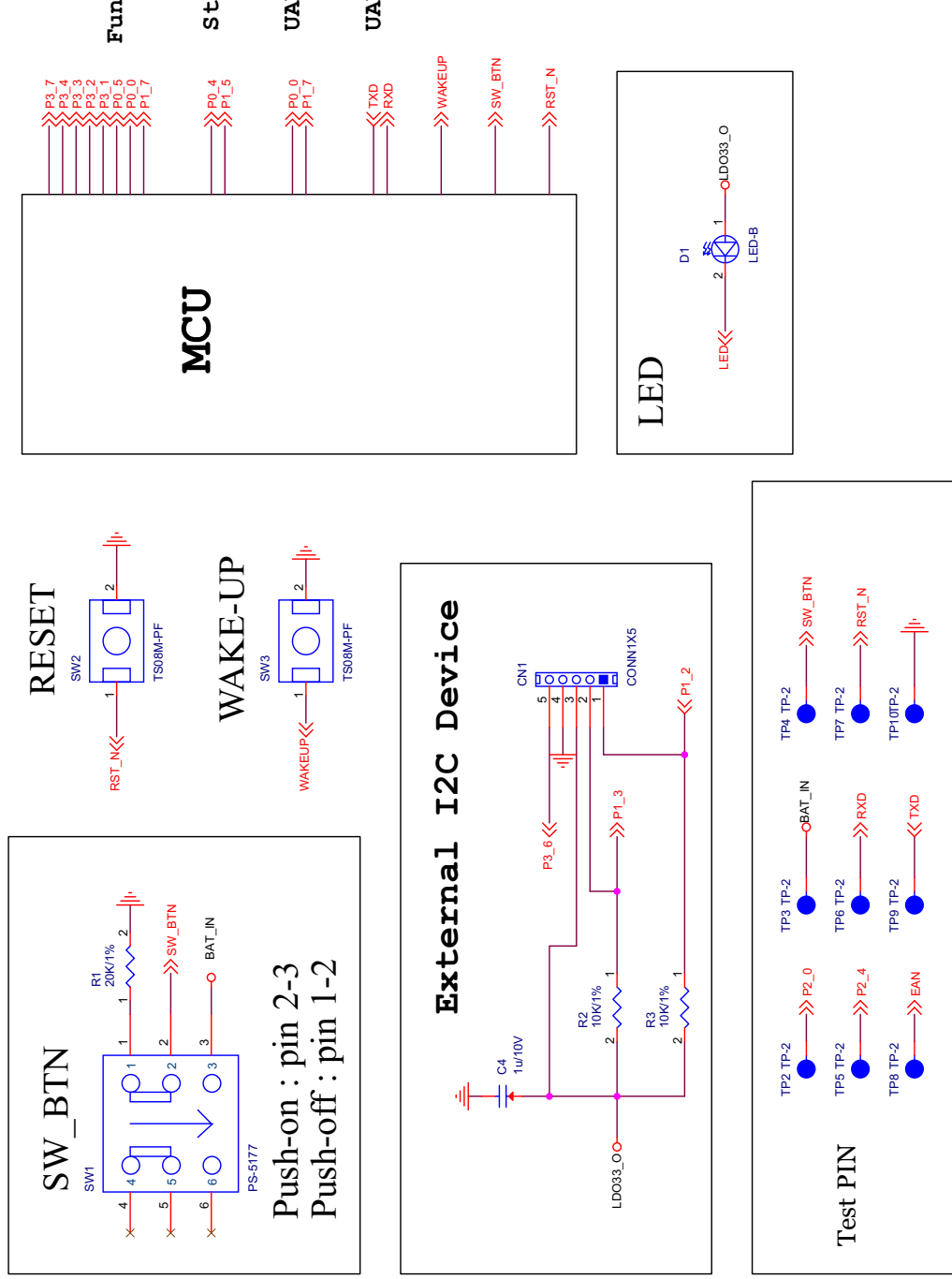

FIGURE 2-12: BM78SPPS5MC2/NC2 REFERENCE CIRCUIT



BM78

NOTES:

3.0 OPERATING MODES

The BM78 module allows the user to operate the module in two distinct modes:

- Auto Pattern mode
- Manual Pattern mode

The Auto Pattern mode and the Manual Pattern mode use different state machines. The BM78 module can be operated in either of these modes by setting the value in the EEPROM memory location. The BM78 module is in Auto Pattern mode by default. To modify the EEPROM values, the module must be placed in the “Write EEPROM and Test mode” through the pins P2_0, P2_4 and EAN.

The UI tool provides an easy Windows Graphical User Interface (GUI) to set or modify the EEPROM settings on the BM78 module.

Note: The UI tool is available for download from the Microchip web site at: www.microchip.com/BM78.

Figure 3-1 illustrates the basic algorithm followed by the BM78 module during startup, in deciding which state machine to be used for operation.

FIGURE 3-1: OPERATING MODE CONFIGURATION

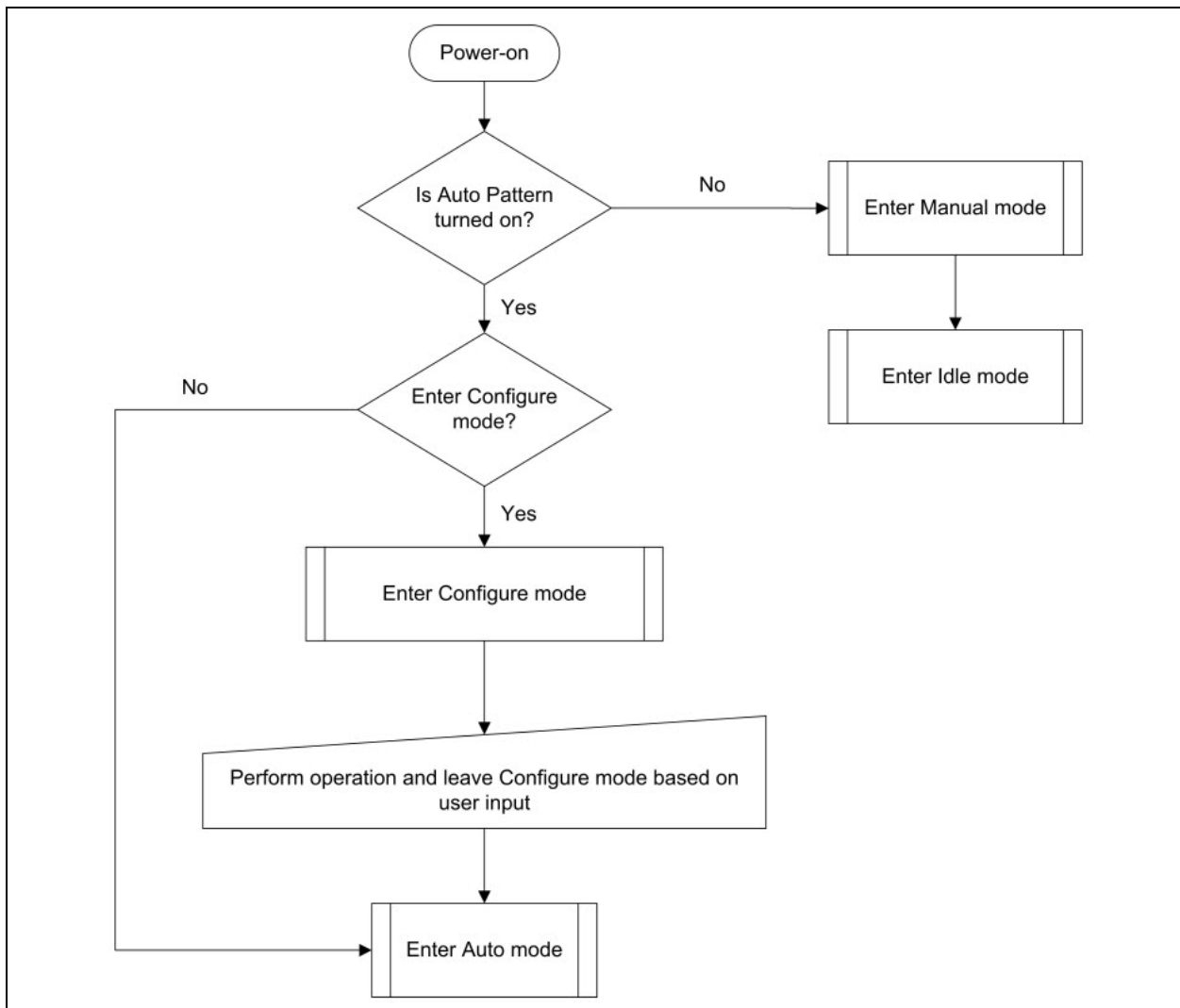

BM78

3.1 Auto Pattern Mode

The Auto Pattern mode is a state machine in which the Bluetooth-related operations are automated. It is primarily used to connect the module to a peer device and create a data pipe with the peer device through the Transparent UART mode, thus providing a “cable replacement” solution. Also, the BM78 module allows

the user to enter some configuration commands in the Auto Pattern mode. For more details on the list of configuration commands that can be used in Auto Pattern mode, refer to the *IS1678 UART Command Set User Guide*.

Figure 3-2 illustrates the basic state machine in the Auto Pattern mode.

FIGURE 3-2: AUTO PATTERN MODE

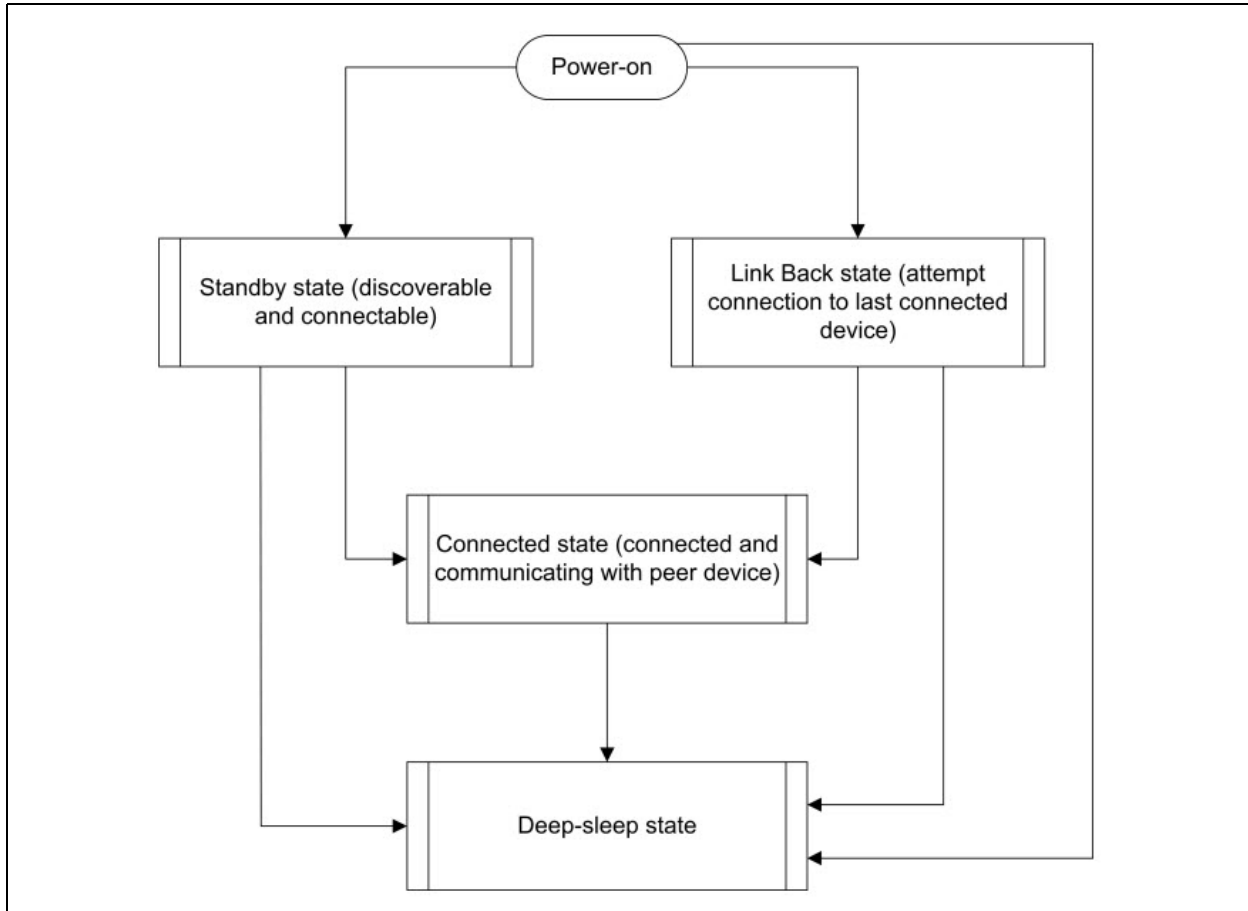

To evaluate and test the BM78 module in Auto Pattern mode, download and install the Auto Pattern tool (Windows-based GUI emulation tool), which is available on the Microchip website. This tool implements the communication protocol for Auto Pattern mode. It also provides a fast and easy way to test the functions and options available in the Auto Pattern mode.

Note: The Auto Pattern tool and *IS1678 UART Command Set User Guide* are available for download from the Microchip website at: www.microchip.com/BM78.

3.2 Manual Pattern

The Manual Pattern mode provides full control of the BM78 module to the user and the module operates only based on the commands from the user or host MCU.

Figure 3-3 illustrates the state machine followed by the BM78 module in the Manual Pattern mode.

FIGURE 3-3: STATE CHANGES BY MCU IN MANUAL PATTERN

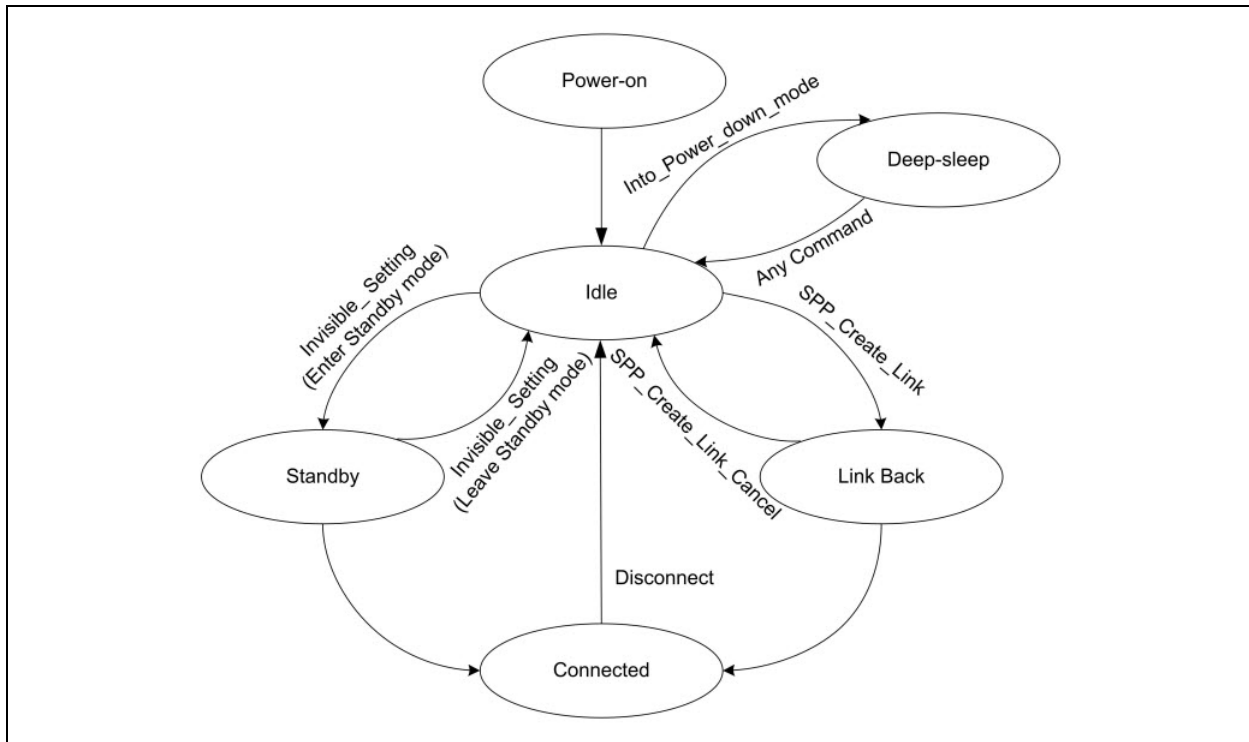

The Manual Pattern mode also allows the Transparent UART mode. There is a small difference in the protocols followed in the Manual Pattern mode and the Auto Pattern mode. For more details on the protocol differences, refer to the *IS1678 UART Command Set User Guide*.

To evaluate and test the BM78 module in Manual Pattern mode, download and install the Manual Pattern tool (Windows-based GUI emulation tool), which is available from the Microchip website. This tool implements the communication protocol for Manual Pattern mode. It also provides a fast and easy way to test the functions and options available in the Manual Pattern mode.

Note: The Manual Pattern tool and *IS1678 UART Command Set User Guide* are available for download from the Microchip website at: www.microchip.com/BM78.

BM78

NOTES:

4.0 ELECTRICAL CHARACTERISTICS

This section provides an overview of the electrical characteristics of the BM78 module. Additional information will be provided in future revisions of this document as it becomes available.

Absolute maximum ratings for the BM78 module are listed below. Exposure to these maximum rating conditions for extended periods may affect device reliability. Functional operation of the device at these or any other conditions, above the parameters indicated in the operation listings of this specification, is not implied.

Absolute Maximum Ratings

Ambient temperature under bias	-20°C to +70°C
Storage temperature	-40°C to +125°C
Voltage on VDD with respect to VSS	-0.3V to +3.6V
Maximum output current sink by any I/O pin.....	12 mA
Maximum output current sourced by any I/O pin.....	12 mA

<p>Note: Stresses listed under “Absolute Maximum Ratings” may cause permanent damage to the device. This is a stress rating only. The functional operation of the device at those or any other conditions and those indicated in the operation listings of this specification, is not implied. Exposure to maximum rating conditions for extended periods may affect device reliability.</p>
--

BM78

Table 4-1 through Table 4-7 provide the recommended operating conditions and the electrical specifications of the BM78 module.

TABLE 4-1: RECOMMENDED OPERATING CONDITIONS

Rating		Min.	Typical	Max.
Ambient Operating temperature range		-20°C	+25°C	+70°C
Relative Humidity (Operating)		10%	—	90%
Relative Humidity (Storage)		10%	—	90%
ESD	HBM	—	±2KV	—
	MM	—	±200V	—
HTOL (Note 1)		—	1000 hrs	—
Supply voltage: BAT_IN		3.3V	—	4.2V
Supply voltage: 1V8, VCC_RF, VDD_XO, AVDD_SAR		1.8V	1.9V	2.1V
SW_BTN		3.3V	—	4.2V
LED1		—	—	3.6V
Reset V_{THRES} threshold voltage		—	1.6V	—
V_{IL} input logic levels low		-0.3V	—	0.8V
V_{IH} input logic levels high		2.0V	—	3.6V
V_{OL} output logic levels low ($I_{OL} = 12$ mA)		—	—	0.4V
V_{OH} output logic levels high ($I_{OH} = 12$ mA)		2.4V	—	—
RF continuous Tx mode		—	—	43 mA
RF continuous Rx mode		—	—	37 mA

Note 1: HTOL life test condition: +125°C, BAT_IN = 4.2V, LDO33_O = 3.3V, LDO18_O = 1.9V.

TABLE 4-2: 3.3V LDO ELECTRICAL PARAMETERS

Parameter	Min.	Typical	Max.	Unit
Operating Temperature	-20	—	+70	°C
Output Current ($V_{IN} = 3.6$ V/load regulation with 100mV drop)	—	100	—	mA
Quiescent Current ($V_{IN} = 3.6$ V)	—	150	—	µA

Note 1: With 10 µF capacitor at LDO33_O as the condition for IP verification.

2: Output voltage can be calibrated using the MP tool.

TABLE 4-3: PMU LDO

Parameter	Min.	Typical	Max.	Unit
Operating Temperature	-20	—	+70	°C
Output Current ($V_{IN} = 3.6$ V/load regulation with 0.3mV drop)	—	100	—	µA
Quiescent Current ($V_{IN} = 3.6$ V)	—	120	—	µA

Note 1: With 1 µF capacitor at PMULDO_O as the condition for IP verification.

2: Output voltage can be calibrated by using the MP tool.

TABLE 4-4: SAR-ADC AND BATTERY VOLTAGE DETECTOR

Parameter	Min.	Typical	Max.	Unit
Operating Temperature	-20	—	+70	°C
AVDD_SAR power supply	—	1.8	—	V
SAR_BAT detection (Note 1)	3.3	—	4.2	V
Resolution	—	10	—	bit
Operating Current (including bandgap)	—	—	1	mA
Deep-sleep Current	—	—	1	μA

Note 1: SAR_BAT is connected with BAT_IN internally for battery voltage detection.

TABLE 4-5: INTENSITY CONTROLLABLE LED DRIVER

Parameter	Min.	Typical	Max.	Unit
Operating Temperature	-20	—	+70	°C
Open-drain Voltage	—	—	3.6	V
Current Step	—	0.3	—	mA
Programmable Current Range	0	—	5	mA
Intensity Control	—	16	—	step
Power Down Open-drain current	—	—	1	μA
Deep-sleep Current	—	—	1	μA

TABLE 4-6: POWER CONSUMPTION-CLASSIC

Test Condition	Current Consumption (avg.) (mA)	Remarks
Standby mode	2.543	—
Deep-Sleep mode	0.187	—
Connected+Sniff, Master (no data)	0.541	No data was transmitted Sniff interval = 500 ms
Connected+Sniff, Slave (no data)	0.551	No data was transmitted Sniff interval = 500 ms
Data, Master	10.67	Data transmitted at 115200 bps; block size = 500
Data, Slave	14.87	Data transmitted at 115200 bps; block size = 500

Note 1: Classic BR/EDR and RX_IND functions are enabled.

2: The data corresponds to BM78SPPx5NC2 (ROM variant).

BM78

TABLE 4-7: POWER CONSUMPTION-LOW ENERGY

Test Condition	Current Consumption (avg.) (mA)	Remarks
Deep-Sleep mode	0.13	—
LE fast advertising	1.21	LE fast advertising interval = 100 ms
	0.88	LE fast advertising interval = 160 ms
	0.48	LE fast advertising interval = 500 ms
	1.72	LE fast advertising interval = 100 ms+ Beacon 100 ms
	0.62	LE fast advertising interval = 500 ms+ Beacon 500 ms
Reduced power advertising	0.39	LE Reduced Power advertising interval = 961 ms
	1.00	LE Reduced Power advertising interval = 961 ms+Beacon 100 ms
	0.51	LE Reduced Power advertising interval = 961 ms+Beacon 500 ms
Connected (No data)	0.39	Connection interval = 1500 ms
	0.43	Connection interval = 600 ms
Connected (iPhone 6 to module)	0.45	Connection interval = 500 ms
	0.60	Connection interval = 200 ms
Connected (module to iPhone 6)	6.6	Connection interval = 500 ms
	7.0	Connection interval = 200 ms

Note 1: Low energy, RX_IND function is enabled.

2: Data corresponds to the BM78SPPx5NC2 (ROM variant).

5.0 RADIO CHARACTERISTICS

Table 5-1 provides the transmitter performance characteristics of the BM78 module.

TABLE 5-1: TRANSMITTER PERFORMANCE

Basic Data Rate	Min.	Typical	Max.	Bluetooth Specification	Unit
BDR power	—	1.5	—	-6 ~ +4	dBm
EDR (2M/3M) power	—	-1	—	-6 ~ +4	
LE power	—	0.5	—	-20 ~ +10	

Note 1: The RF Transmit power can be calibrated during production by using the MP tool and the MT8852 Bluetooth test equipment.

2: Test condition: VCC RF = 1.80V, temperature = +25°C.

Table 5-2 provides the receiver performance characteristics of the BM78 module.

TABLE 5-2: RECEIVER PERFORMANCE

Basic Data Rate	Min.	Typical	Max.	Bluetooth Specification	Unit
BDR Sensitivity	—	-90	—	≤-70	dBm
EDR 2M Sensitivity	—	-90	—		
EDR 3M Sensitivity	—	-82	—		
LE Sensitivity	—	-92	—		

Note: Test condition: VCC RF = 1.80V, temperature = +25°C.

BM78

NOTES:

6.0 PHYSICAL DIMENSIONS

Figure 6-1 illustrates the physical dimensions of the BM78SPPS5MC2/NC2 module.

FIGURE 6-1: BM78SPPS5MC2/NC2 MODULE DIMENSIONS

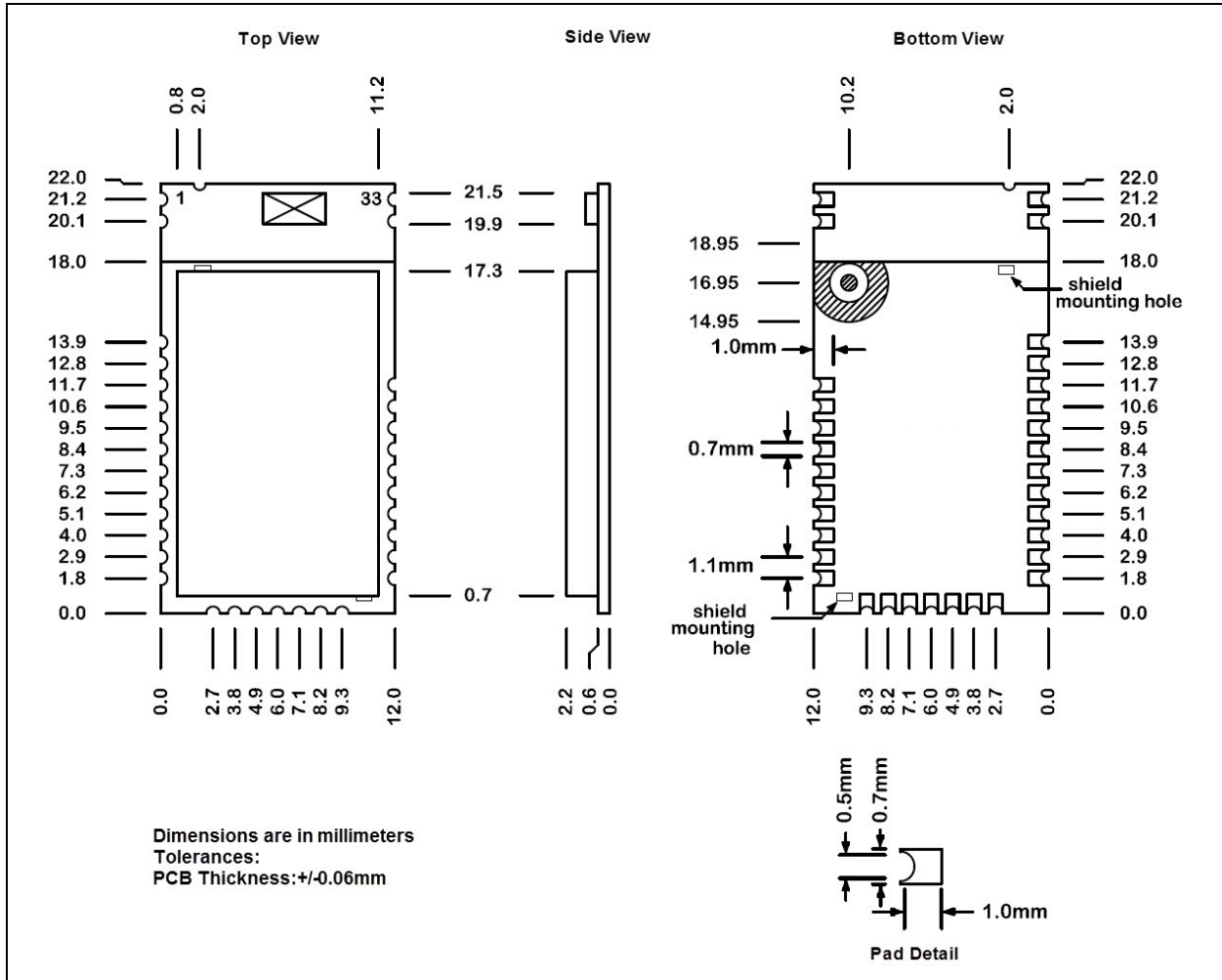

BM78

Figure 6-2 illustrates the recommended host PCB footprint.

FIGURE 6-2: BM78SPPS5MC2/NC2 RECOMMENDED PCB FOOTPRINT

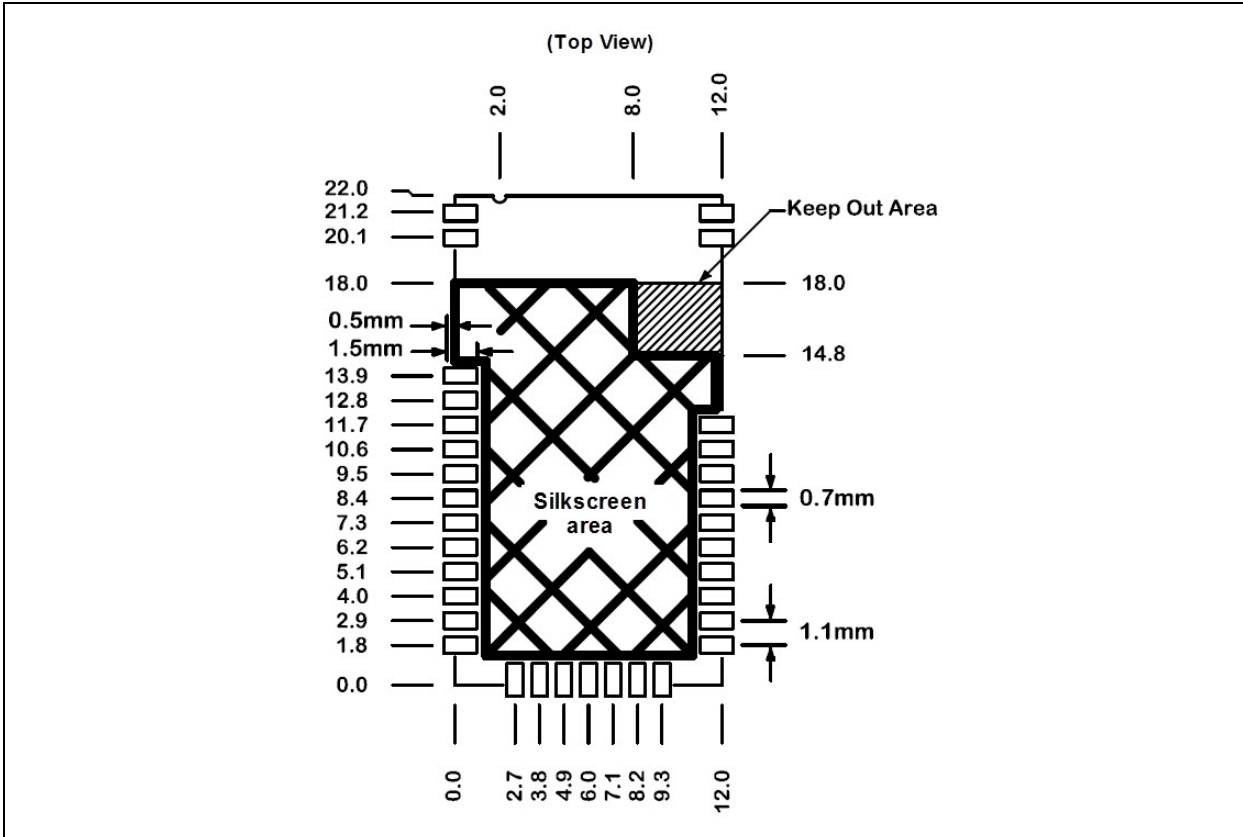
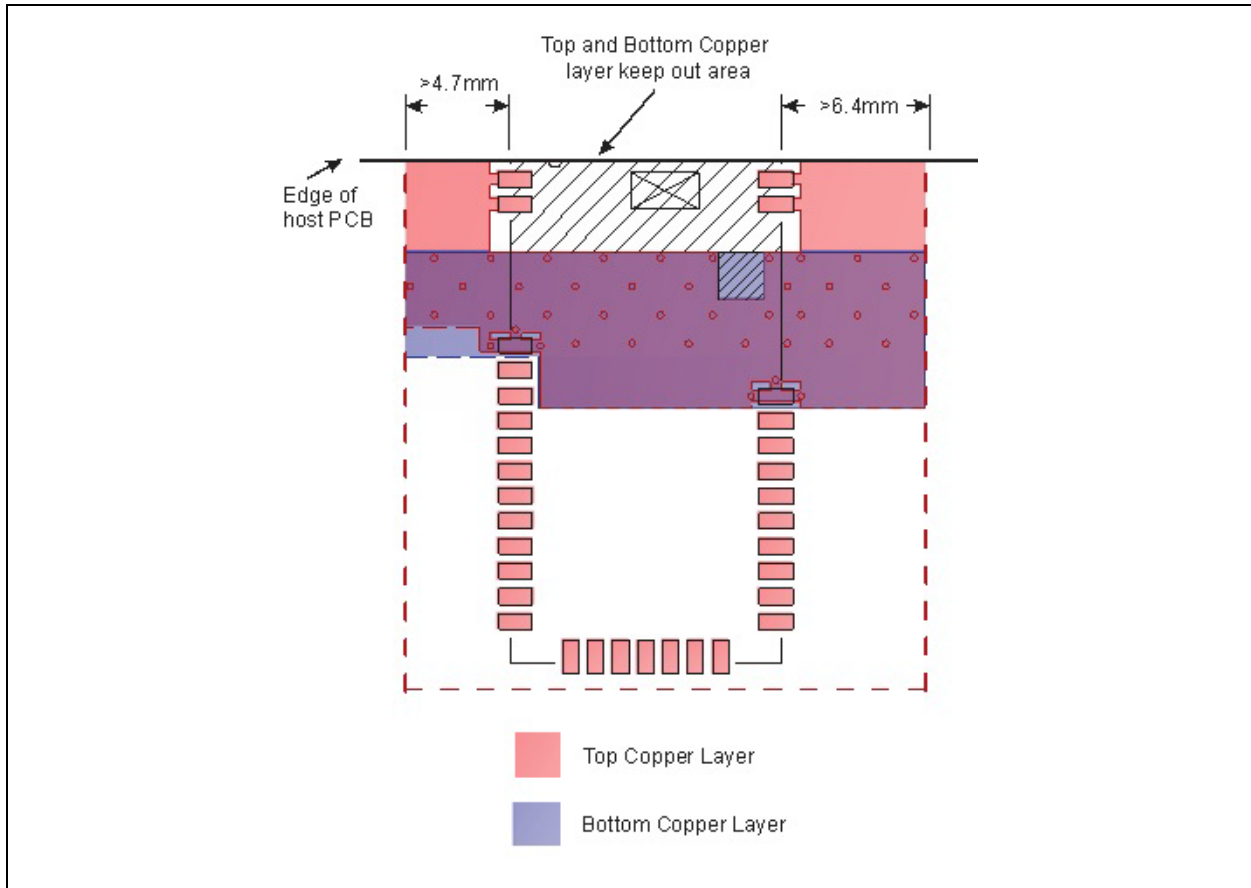

Figure 6-3 illustrates the recommendations for mounting the BM78SPPS5MC2/NC2 on the host PCB, and shows the minimum ground plane area to the left and right of the module for the best antenna performance.

Avoid the top copper layer near the test pin area. When designing the host PCB, the areas under the antenna should not contain any top, inner, or bottom copper layer. A low-impedance ground plane will ensure best radio performance (best range and lowest noise). The ground plane can be extended beyond the minimum recommended, as needed for host PCB EMC noise

reduction. For best range performance, keep all external metal at least 31 mm away from the ceramic chip antenna.

FIGURE 6-3: BM78SPPS5MC2/NC2 HOST PCB MOUNTING SUGGESTION



BM78

Figure 6-4 illustrates the physical dimensions of the BM78SPP05MC2/NC2 module.

FIGURE 6-4: BM78SPP05MC2/NC2 MODULE DIMENSIONS

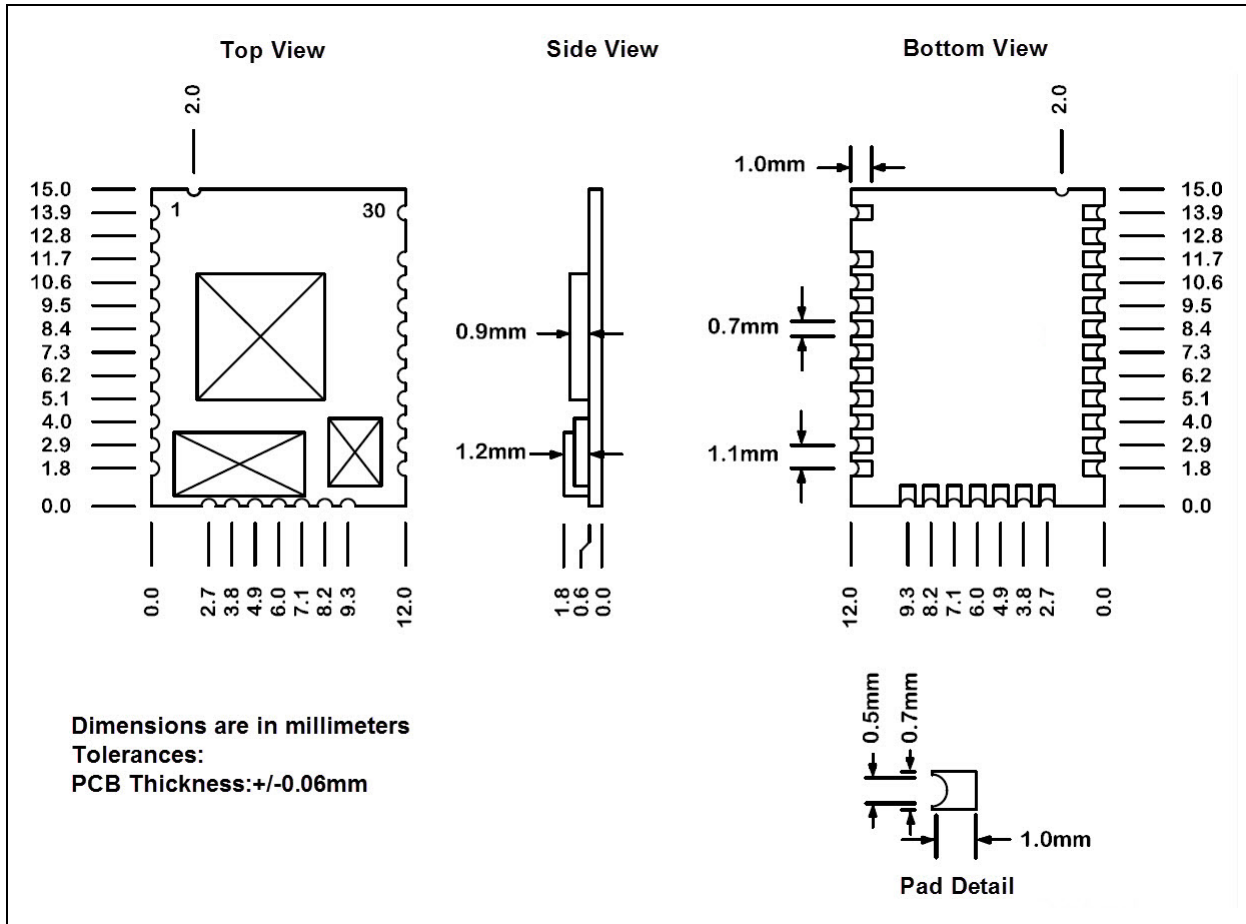
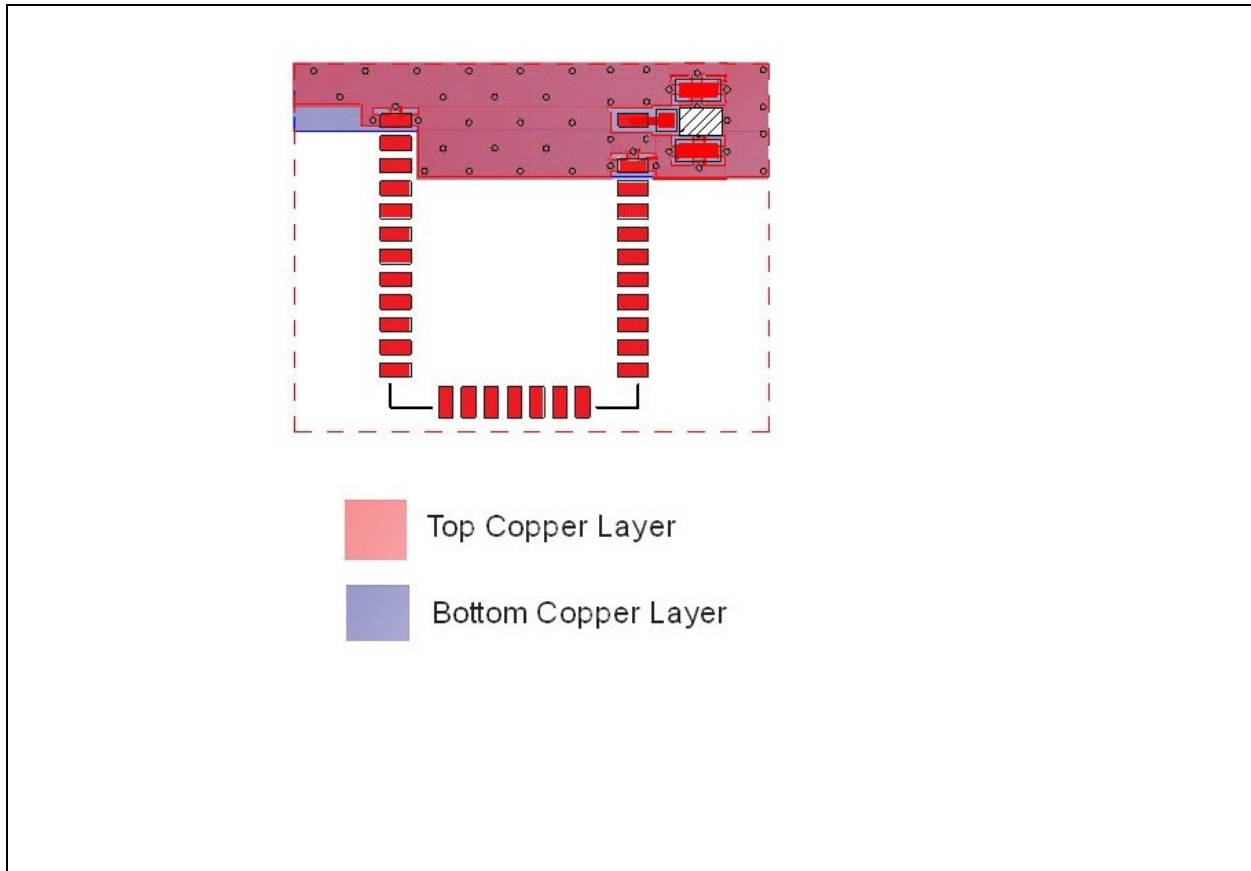

Figure 6-5 illustrates the recommended host PCB footprint.

FIGURE 6-5: BM78SPP05MC2/NC2 RECOMMENDED PCB FOOTPRINT



BM78

Figure 6-6 illustrates the recommended mounting details for the BM78SPP05MC2/NC2 module and recommended layout of the host PCB.

A low-impedance ground plane will ensure best radio performance (best range, lowest noise). The Pin 30 (BT_RF) is a 50 Ohm connection to an external antenna connector, PCB trace antenna, or component (ceramic chip) antenna through a host PCB with 50 Ohm impedance and micro-strip trace. This trace can be extended to include passive parts for antenna attenuation padding, impedance matching, or to provide test posts. It is recommended that the micro-strip

trace must be as short as possible for minimum loss and better impedance matching. If the micro-strip trace is longer, it must be a 50 Ohm impedance.

FIGURE 6-6: BM78SPP05MC2/NC2 HOST PCB MOUNTING SUGGESTION

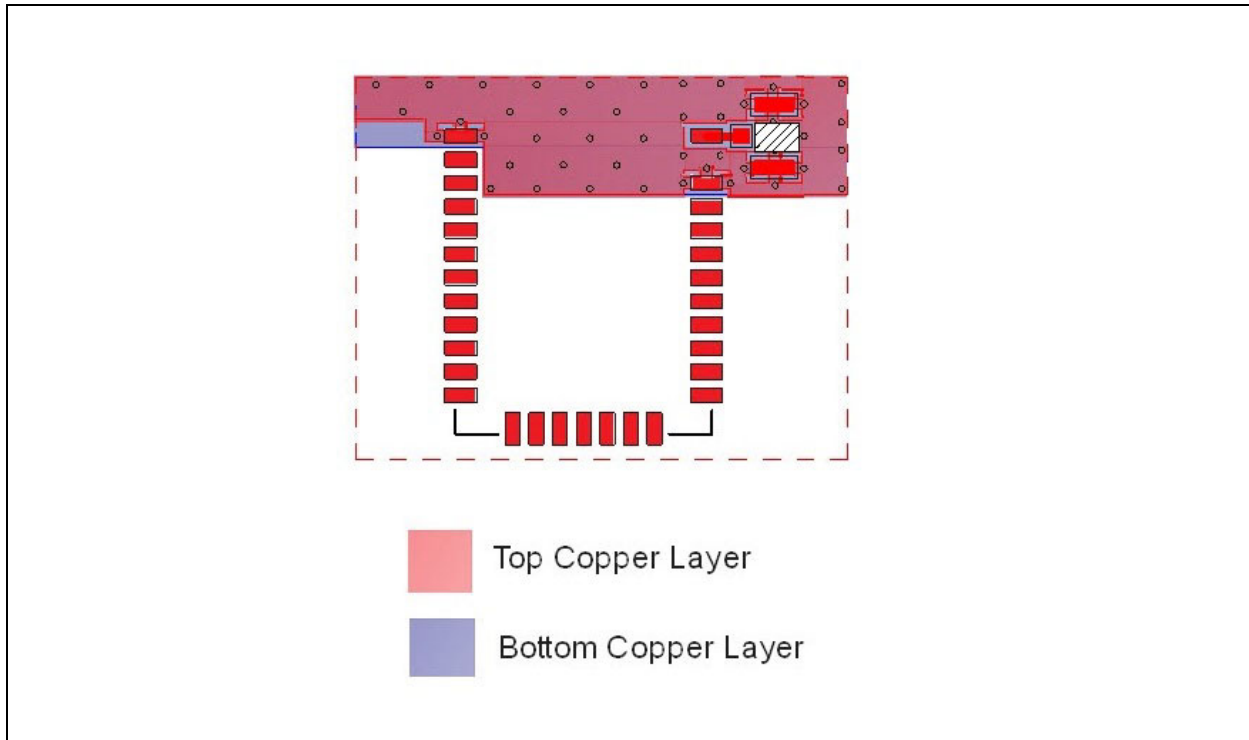

7.0 REFLOW PROFILE MODULE

The BM78 module is assembled using a standard lead-free reflow profile, IPC/JEDEC J-STD-020. The BM78 module can be soldered to the host PCB by using the standard leaded and lead-free solder reflow profiles.

To avoid damage to the module, follow these recommendations:

- Refer to *AN233 Solder Reflow Recommendation* application note (DS00233) for the soldering reflow recommendations
- The peak temperature should not exceed (T_P) of +250°C
- Use no-clean flux solder paste
- Do not wash the module as moisture can be trapped under the shield
- Use only one flow. If the PCB requires multiple flows, apply the module on the final flow
- Standard: IPC/JEDEC J-STD-020:

- Condition: Preheat: +150°C to +200°C for 60 to 120 seconds
- Average ramp-up rate (+217°C to peak): +3°C/sec max
- Temperature maintained above +217°C: 60 to 150 seconds
- Time within +5°C of peak temperature: 30 to 40 seconds
- Peak temperature: +260°C with +5/0°C tolerance
- Ramp-down rate (peak to +217°C): +6°C/sec max
- Time within +25°C to peak temperature: 8 minutes max
- Cycle interval 5 minutes

Figure 7-1 illustrates the reflow profile of the BM78 module.

FIGURE 7-1: REFLOW PROFILE

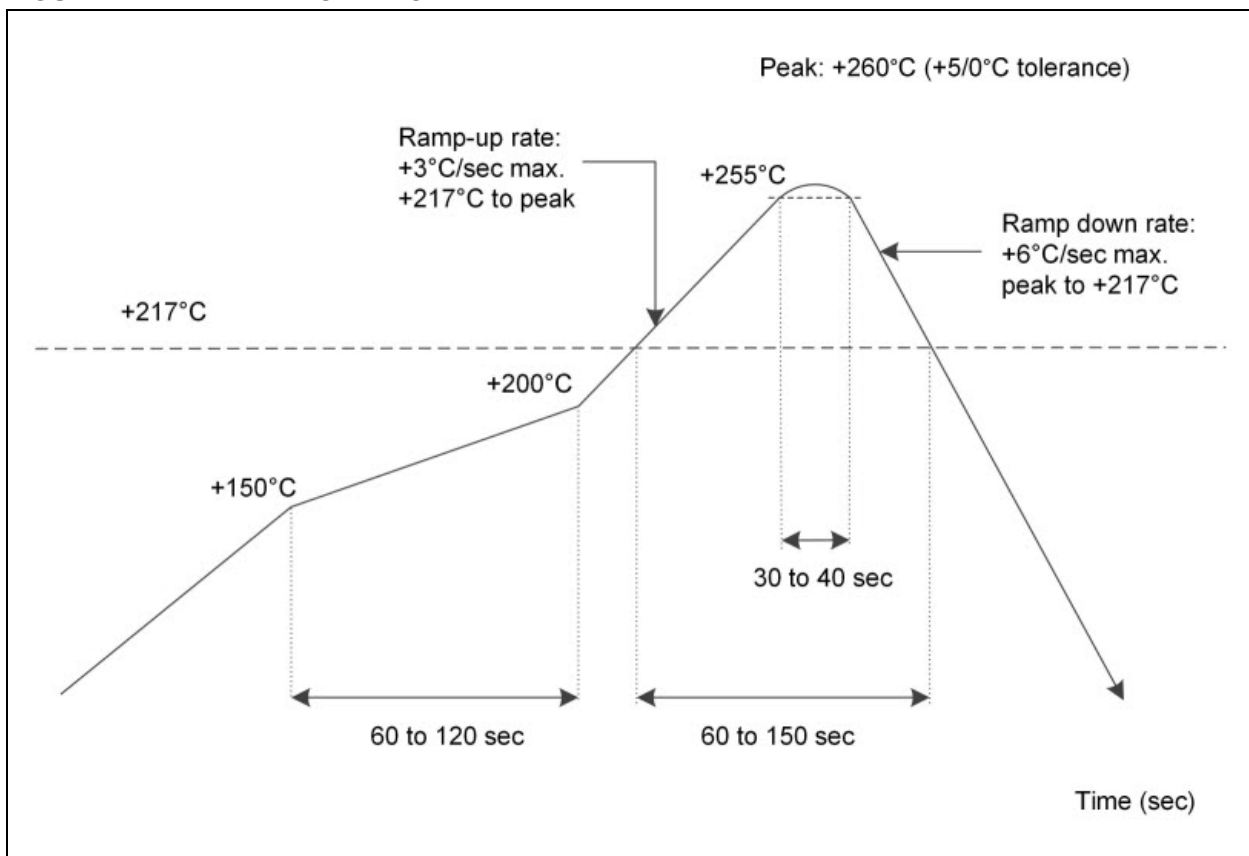

BM78

NOTES:

8.0 MODULE PLACEMENT GUIDELINES

For a Bluetooth wireless product, the antenna placement affects the performance of the whole system. The antenna requires free space to radiate the RF signal and it cannot be surrounded by the ground plane. Microchip recommends that the areas underneath the antenna on the host PCB do not contain copper on the top, inner, or bottom layer.

The ground plane can be extended beyond the minimum recommendation as required for the main PCB EMC noise reduction. For the best range performance, keep all external metal at least 15 mm away from the ceramic chip antenna.

Figure 8-1 illustrates an example of good and poor module placement on a host PCB with the ground plane.

FIGURE 8-1: MODULE PLACEMENT EXAMPLES

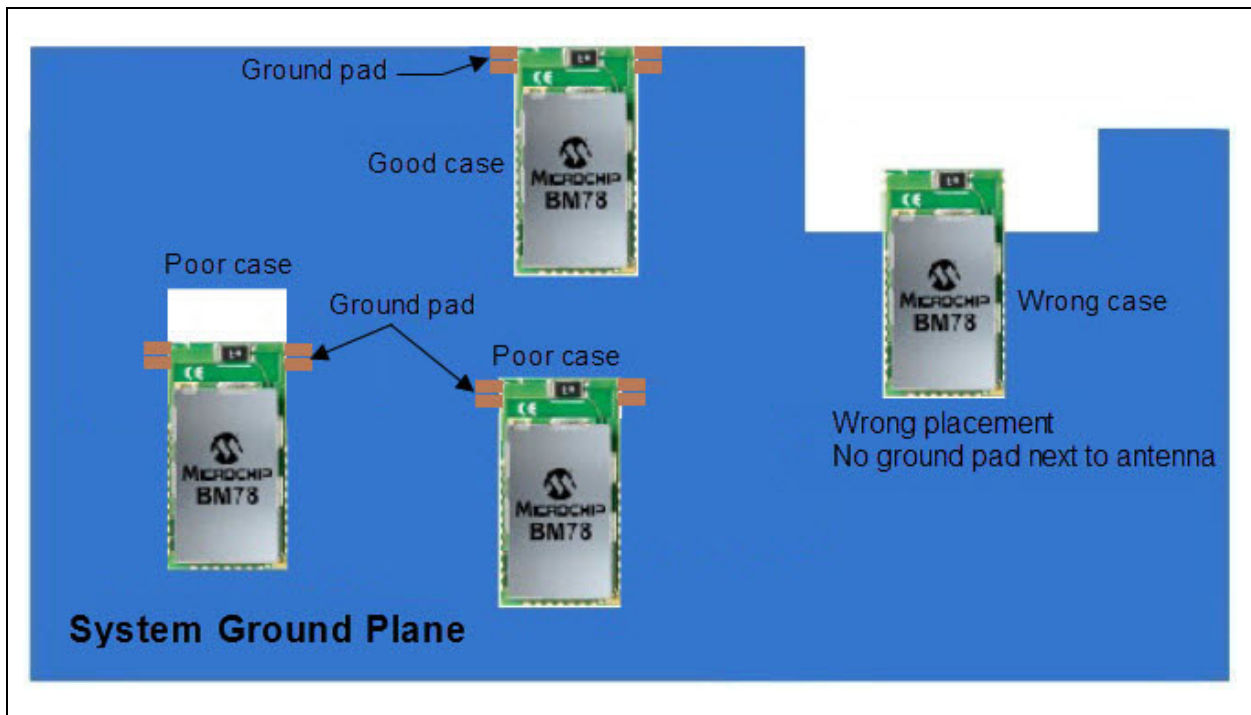

TABLE 8-1: RECOMMENDED ANTENNA

Description	Manufacturer Part Number	Manufacturer
ANT ANT3216A063R2400A PIFA 2.4GHZ L3.2W1.6	ANT3216A063R2400A	YAGEO

BM78

Figure 8-2 illustrates the BM78 module, mounted on the BM78 Evaluation Board (EVB). It also shows the recommended keep out area for the antenna.

FIGURE 8-2: KEEP OUT AREA RECOMMENDED FOR ANTENNA

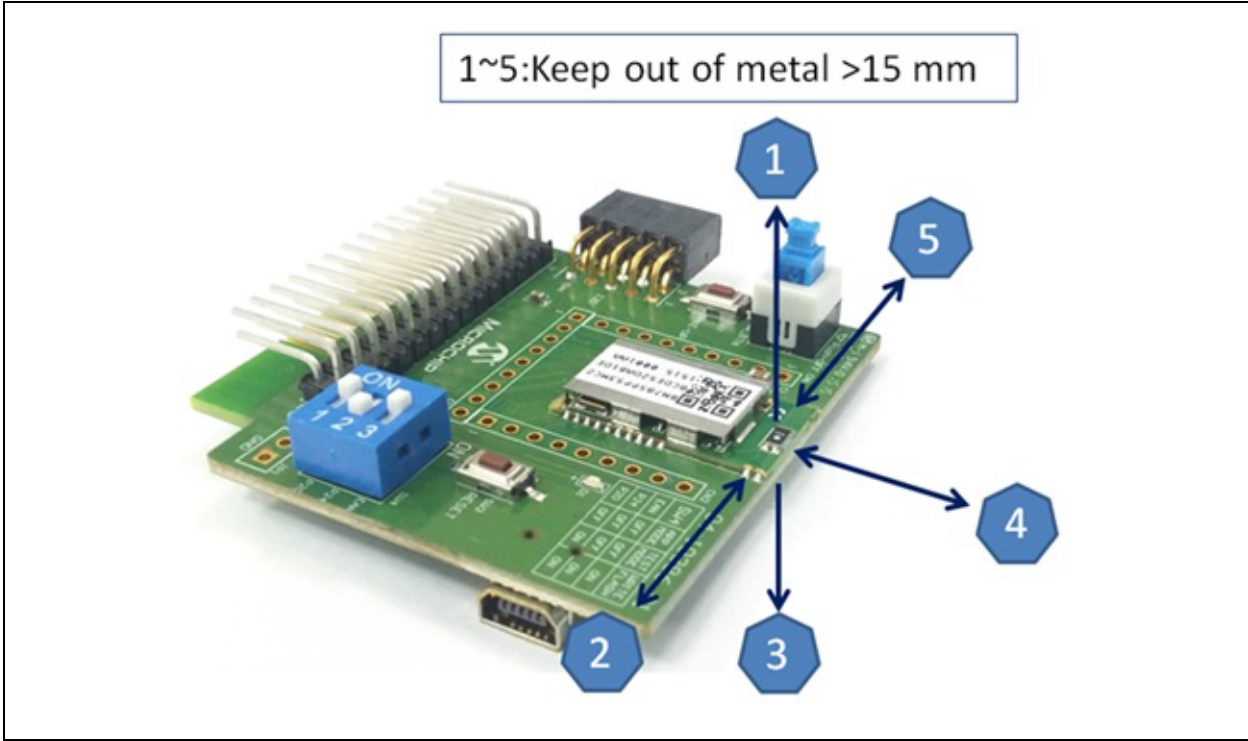

Note: For additional information on free space for antenna placement design, refer to the antenna manufacturer's design rule document.

8.1 BM78SPPS5MC2/NC2 Ceramic Chip Antenna

The BM78SPPS5MC2/NC2 contains an integral ceramic chip antenna. Figure 8-3 illustrates the antenna radiation pattern of the ceramic chip antenna on the BM78SPPS5MC2/NC2.

FIGURE 8-3: BM78SPPS5MC2/NC2 ANTENNA RADIATION PATTERN

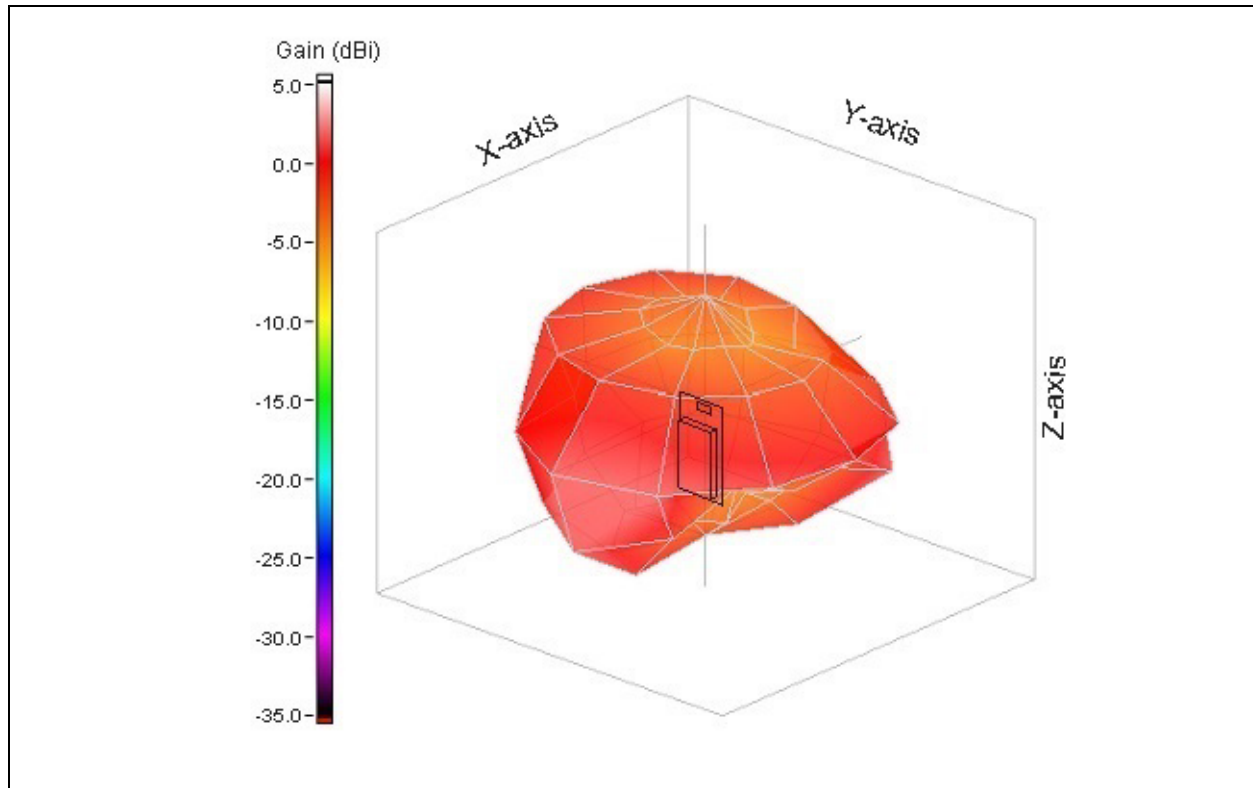

TABLE 8-2: ANTENNA RADIATION PATTERN DETAILS

Parameter	Values
Frequency	2450 MHz
Peak Gain	1.63 dBi
Efficiency	71.55%

BM78

NOTES:

9.0 ORDERING INFORMATION

Table 9-1 provides the various SKUs of the BM78 module.

TABLE 9-1: BM78 MODULE SKUs

Device	Microchip IC	Antenna	Description	Shield	Regulatory Certification
BM78SPPS5MC2	IS1678SM-151	On-board	Bluetooth Dual mode, Class 2, Flash variant	Yes	FCC, ISED, CE, MIC, KCC, NCC, SRRC
BM78SPP05MC2	IS1678SM-151	External	Bluetooth Dual mode, Class 2, Flash variant	No	No
BM78SPPS5NC2	IS1678S-152	On-board	Bluetooth Dual mode, Class 2, ROM variant	Yes	FCC, ISED, CE, MIC, KCC, NCC, SRRC
BM78SPP05NC2	IS1678S-152	External	Bluetooth Dual mode, Class 2, ROM variant	No	No
BM78SPPS5MC2	IS1678SM-152	On-board	Bluetooth Dual mode, Class 2, Flash variant. Firmware Rev 1.35	Yes	FCC, ISED, CE, MIC, KCC, NCC, SRRC
BM78SPP05MC2	IS1678SM-152	External	Bluetooth Dual mode, Class 2, Flash variant. Firmware Rev 1.35	No	No

Note: The BM78 module can be purchased through a Microchip representative. Contact Microchip sales office for information on Blue the BM78 module. Visit www.microchip.com for current pricing and a list of distributors for the product.

BM78

NOTES:

APPENDIX A: CERTIFICATION NOTICES

The **BM78** module (BM78SPPS5MC2) has received regulatory approval for the following countries:

- Bluetooth SIG/QDID: 110108
- United States/FCC ID: A8TBM78ABCDEFGH
- Canada:
 - IC: 12246A-BM78SPPS5M2
 - HVIN: BM78SPPS5M2
 - PMN: Bluetooth Module
- Europe/CE
- Japan/MIC: 202-SMD070
- Korea/KCC: MSIP-CRM-mcp-BM78SPPS5MC2
- Taiwan/NCC No: CCAN15LP0510T4
- China/SRRC: CMIIT ID: 2015DJ7133

The **BM78 ROM** module (BM78SPPS5NC2) will cover regulatory approval for the following countries:

- Bluetooth SIG/QDID: 110108
- United States/FCC ID: A8TBM78ABCDEFGH
- Canada:
 - IC: 12246A-BM78SPPS5M2
 - HVIN: BM78SPPS5M2
 - PMN: BM78SPPS5NC2
- Europe/CE
- Japan/MIC: 202-SMD070
- Korea/KCC: MSIP-CRM-mcp-BM78SPPS5MC2
- Taiwan/NCC No: CCAN18LP0800T1
- China/SRRC: CMIIT ID: 2018DJ3812

A.1 REGULATORY APPROVAL

This section outlines the regulatory information for the BM78 module for the following countries:

- United States
- Canada
- Europe
- Japan
- Korea
- Taiwan
- China
- Other Regulatory Jurisdictions

A.1.1 UNITED STATES

The BM78/BM78 ROM module has received Federal Communications Commission (FCC) CFR47 Telecommunications, Part 15 Subpart C "Intentional Radiators" single-modular approval in accordance with Part 15.212 Modular Transmitter approval. Single-modular transmitter approval is defined as a complete RF transmission sub-assembly, designed to be incorporated into another device, that must demonstrate compliance with FCC rules and policies independent of any host. A

transmitter with a modular grant can be installed in different end-use products (referred to as a host, host product, or host device) by the grantee or other equipment manufacturer, then the host product may not require additional testing or equipment authorization for the transmitter function provided by that specific module or limited module device.

The user must comply with all of the instructions provided by the Grantee, which indicate installation and/or operating conditions necessary for compliance.

The host product itself is required to comply with all applicable FCC equipment authorizations regulations, requirements and equipment functions that are not associated with the transmitter module portion. For example, compliance must be demonstrated to regulations for other transmitter components within a host product; to requirements for unintentional radiators (Part 15 Subpart B), such as digital devices, computer peripherals, radio receivers, etc.; and to additional authorization requirements for the non-transmitter functions on the transmitter module (i.e., Verification, or Declaration of Conformity) (e.g., Bluetooth and Wi-Fi transmitter modules may also contain digital logic functions).

A.1.2 LABELING AND USER INFORMATION REQUIREMENTS

The BM78/BM78 ROM module has been labeled with its own FCC ID number, and if the FCC ID is not visible when the module is installed inside another device, then the outside of the finished product into which the module is installed must also display a label referring to the enclosed module. This exterior label can use wordings as follows:

Contains Transmitter Module
FCC ID: A8TBM78ABCDEFGH

or

Contains FCC ID:A8TBM78ABCDEFGH

This device complies with Part 15 of the FCC Rules. Operation is subject to the following two conditions: (1) this device may not cause harmful interference, and (2) this device must accept any interference received, including interference that may cause undesired operation.

BM78

A user's manual for the product must include the following statement:

This equipment has been tested and found to comply with the limits for a Class B digital device, pursuant to part 15 of the FCC Rules. These limits are designed to provide reasonable protection against harmful interference in a residential installation. This equipment generates, uses and can radiate radio frequency energy, and if not installed and used in accordance with the instructions, may cause harmful interference to radio communications. However, there is no guarantee that interference will not occur in a particular installation. If this equipment does cause harmful interference to radio or television reception, which can be determined by turning the equipment off and on, the user is encouraged to try to correct the interference by one or more of the following measures:

- Reorient or relocate the receiving antenna
- Increase the separation between the equipment and receiver
- Connect the equipment into an outlet on a circuit different from that to which the receiver is connected
- Consult the dealer or an experienced radio/TV technician for help

Additional information on labeling and user information requirements for Part 15 devices can be found in KDB Publication 784748 available at the FCC Office of Engineering and Technology (OET) Laboratory Division Knowledge Database (KDB)
<http://apps.fcc.gov/oetcf/kdb/index.cfm>.

A.1.3 RF EXPOSURE

All transmitters regulated by FCC must comply with RF exposure requirements. KDB 447498 General RF Exposure Guidance provides guidance in determining whether proposed or existing transmitting facilities, operations or devices comply with limits for human exposure to Radio Frequency (RF) fields adopted by the Federal Communications Commission (FCC).

From the FCC Grant: Output power listed is conducted. This grant is valid only when the module is sold to OEM integrators and must be installed by the OEM or OEM integrators. This transmitter is restricted for use with the specific antenna(s) tested in this application for Certification and must not be co-located or operating in conjunction with any other antenna or transmitters within a host device, except in accordance with FCC multi-transmitter product procedures.

A.1.4 HELPFUL WEB SITES

Federal Communications Commission (FCC):
<http://www.fcc.gov>

FCC Office of Engineering and Technology (OET) Laboratory Division Knowledge Database (KDB):
<http://apps.fcc.gov/oetcf/kdb/index.cfm>

A.2 Canada

The BM78/BM78 ROM module has been certified for use in Canada under Innovation, Science and Economic Development Canada (ISED, formerly Industry Canada) Radio Standards Procedure (RSP) RSP-100, Radio Standards Specification (RSS) RSS-Gen and RSS-247. Modular approval permits the installation of a module in a host device without the need to recertify the device.

A.2.1 LABELING AND USER INFORMATION REQUIREMENTS

Labeling Requirements (from RSP-100, Issue 11, Section 3): The host product shall be properly labeled to identify the module within the host device.

The Innovation, Science and Economic Development Canada certification label of a module shall be clearly visible at all times when installed in the host product, otherwise the host device must be labeled to display the Innovation, Science and Economic Development Canada certification number of the module, preceded by the word "Contains", or similar wording expressing the same meaning, as follows:

Contains IC: 12246A-BM78SPPS5M2

User Manual Notice for License-Exempt Radio Apparatus (from Section 8.4 RSS-Gen, Issue 4, November 2014): User manuals for license-exempt radio apparatus shall contain the following or equivalent notice in a conspicuous location in the user manual or alternatively on the device or both:

This device complies with Industry Canada's license-exempt RSS standard(s). Operation is subject to the following two conditions:

- (1) This device may not cause interference, and**
- (2) This device must accept any interference, including interference that may cause undesired operation of the device.**

Le présent appareil est conforme aux CNR d'Industrie Canada applicables aux appareils radio exempts de licence. L'exploitation est autorisée aux deux conditions suivantes:

- (1) l'appareil ne doit pas produire de brouillage, et**
- (2) l'utilisateur de l'appareil doit accepter tout brouillage radioélectrique subi, même si le brouillage est susceptible d'en compromettre le fonctionnement.**

Guidelines on Transmitter Antenna for License Exempt Radio Apparatus:

Under Industry Canada regulations, this radio transmitter may only operate using an antenna of a type and maximum (or lesser) gain approved for the transmitter by Industry Canada. To reduce potential radio interference to other users, the antenna type and its gain must be so chosen that the equivalent isotropically radiated power (e.i.r.p.) is not more than that necessary for successful communication.

Conformément à la réglementation d'Industrie Canada, le présent émetteur radio peut fonctionner avec une antenne d'un type et d'un gain maximal (ou inférieur) approuvé pour l'émetteur par Industrie Canada. Dans le but de réduire les risques de brouillage radioélectrique à l'intention des autres utilisateurs, il faut choisir le type d'antenne et son gain de sorte que la puissance isotrope rayonnée équivalente (p.i.r.e.) ne dépasse pas l'intensité nécessaire à l'établissement d'une communication satisfaisante.

The ETSI provides guidance on modular devices in “*Guide to the application of harmonised standards covering Article 3.1(b) and Article 3.2 of the Directive 2014/53/EU RED to multi-radio and combined radio and non-radio equipment*” document available at: http://www.etsi.org/deliver/etsi_eg/203300_203399/203367/01.01.01_60/eg_203367v010101p.pdf

Note: To maintain conformance to the testing listed in [Table A-1](#), the module shall be installed in accordance with the installation instructions in this data sheet and shall not be modified.
When integrating a radio module into a completed product the integrator becomes the manufacturer of the final product and is therefore responsible for demonstrating compliance of the final product with the essential requirements against the RED.

A.2.2 RF EXPOSURE

All transmitters regulated by the Innovation, Science and Economic Development Canada (ISED) must comply with RF exposure requirements listed in RSS-102 - Radio Frequency (RF) Exposure Compliance of Radio communication Apparatus (All Frequency Bands).

This transmitter is restricted for use with a specific antenna tested in this application for certification, and must not be co-located or operating in conjunction with any other antenna or transmitters, except in accordance with Innovation, Science and Economic Development Canada multi-transmitter guidelines.

The device operates at an output power level which is within the ISED SAR test exemption limits at any user distance.

A.2.3 HELPFUL WEB SITES

Innovation, Science and Economic Development Canada (ISED): <http://www.ic.gc.ca/>

A.3 Europe

The BM78/BM78 ROM module is an Radio Equipment Directive (RED) assessed radio module that is CE marked and has been manufactured and tested with the intention of being integrated into a final product.

The BM78/BM78 ROM module has been tested to RED 2014/53/EU Essential Requirements for Health and Safety (Article (3.1(a)), Electromagnetic Compatibility (EMC) (Article 3.1(b)), and Radio (Article 3.2) and are summarized in [Table A-1](#).

BM78

A.3.1 LABELING AND USER INFORMATION REQUIREMENTS

The label on the final product which contains the BM78/BM78 ROM module must follow CE marking requirements.

TABLE A-1: EUROPEAN COMPLIANCE TESTING

Certification	Standards	Article	Laboratory	Report Number	Date
Safety	EN 60950-1:2006+A11:2009 +A1:2010 +A12:2011+A2:2013	[3.1(a)]	TUV Rheinland	10052799 001	2015-10-30
Health	EN 300 328 V1.9.1 EN 62479:2010			10052796 001 10052797 001	2015-12-21
EMC	EN 301 489-1 V1.9.2	[3.1(b)]		10052437 001	2015-09-14
	EN 301 489-17 V2.2.1				
	EN 301 489-1 V2.1.1				
	EN 301 489-1 V2.2.0				
	EN 301 489-17 V3.1.1				
	EN 301 489-17 V3.2.0			10052437 002	2017-05-26
Radio	EN 300 328 V1.9.1	(3.2)		10052796 001 10052797 001	2015-12-21
	EN 300 328 V2.1.1			10052796 002 10052797 002	2017-05-26

A.3.2 CONFORMITY ASSESSMENT

From ETSI Guidance Note EG 203367, section 6.1 Non-radio products are combined with a radio product: If the manufacturer of the combined equipment installs the radio product in a host non-radio product in equivalent assessment conditions (i.e. host equivalent to the one used for the assessment of the radio product) and according to the installation instructions for the radio product, then no additional assessment of the combined equipment against article 3.2 of the RED is required.

The European Compliance Testing listed in [Table A-1](#) was performed using the Integral Ceramic Chip antenna.

A.3.2.1 Simplified EU Declaration of Conformity

Hereby, Microchip Technology Inc. declares that the radio equipment type BM78/BM78 ROM is in compliance with Directive 2014/53/EU.

The full text of the EU declaration of conformity, for this product, is available at:

<http://www.microchip.com/design-centers/wireless-connectivity>

A.3.3 HELPFUL WEBSITES

A document that can be used as a starting point in understanding the use of Short Range Devices (SRD) in Europe is the European Radio Communications

Committee (ERC) Recommendation 70-03 E, which can be downloaded from the European Communications Committee (ECC) at: <http://www.ecodocdb.dk/>

Additional helpful web sites are:

- Radio Equipment Directive (RED):
https://ec.europa.eu/growth/single-market/european-standards/harmonised-standards/red_en
- European Conference of Postal and Telecommunications Administrations (CEPT):
<http://www.cept.org>
- European Telecommunications Standards Institute (ETSI):
<http://www.etsi.org>
- The Radio Equipment Directive (RED):
<http://www.redca.eu/>

A.4 Japan

The BM78/BM78 ROM module has received type certification and is labeled with its own technical conformity mark and certification number as required to conform to the technical standards regulated by the Ministry of Internal Affairs and Communications (MIC) of Japan pursuant to the Radio Act of Japan.

Integration of this module into a final product does not require additional radio certification provided installation instructions are followed and no modifications of the module are allowed. Additional testing may be required:

- If the host product is subject to electrical appli-

ance safety (for example, powered from an AC mains), the host product may require Product Safety Electrical Appliance and Material (PSE) testing. The integrator must contact their conformance laboratory to determine if this testing is required

- There is an voluntary Electromagnetic Compatibility (EMC) test for the host product administered by VCCI: http://www.vcci.jp/vcci_e/index.html

A.4.1 LABELING AND USER INFORMATION REQUIREMENTS

The label on the final product which contains the BM78 module must follow Japan marking requirements. The integrator of the module must refer to the labeling requirements for Japan available at the Ministry of Internal Affairs and Communications (MIC) website.

The BM78 module is labeled with its own technical conformity mark and certification number. The final product in which this module is being used must have a label referring to the type certified module inside:

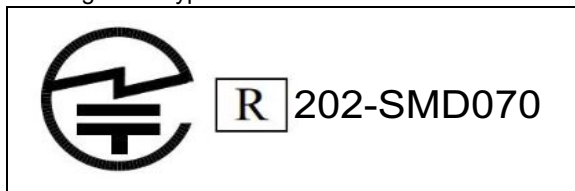

A.4.2 HELPFUL WEB SITES

Ministry of Internal Affairs and Communications (MIC): <http://www.tele.soumu.go.jp/e/index.htm>

Association of Radio Industries and Businesses (ARIB): <http://www.arib.or.jp/english/>

A.5 Korea

The BM78/BM78 ROM module has received certification of conformity in accordance with the Radio Waves Act. Integration of this module into a final product does not require additional radio certification provided installation instructions are followed and no modifications of the module are allowed.

A.5.1 LABELING AND USER INFORMATION REQUIREMENTS

The label on the final product which contains the BM78/BM78 ROM module must follow KC marking requirements. The integrator of the module must refer to the labeling requirements for Korea available on the Korea Communications Commission (KCC) website.

The BM78 module is labeled with its own KC mark. The final product requires the KC mark and certificate number of the module:

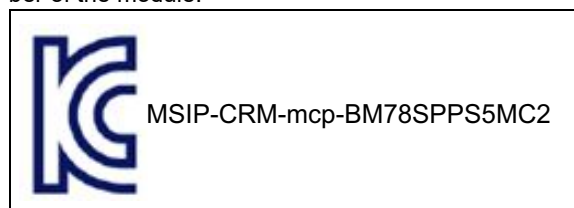

A.5.2 HELPFUL WEB SITES

Korea Communications Commission (KCC): <http://www.kcc.go.kr>

National Radio Research Agency (RRA): <http://rra.go.kr>

A.6 Taiwan

The BM78/BM78 ROM module has received compliance approval in accordance with the Telecommunications Act. Customers seeking to use the compliance approval in their product must contact Microchip Technology Inc. sales or distribution partners to obtain a Letter of Authority.

Integration of this module into a final product does not require additional radio certification provided installation instructions are followed and no modifications of the module are allowed.

A.6.1 LABELING AND USER INFORMATION REQUIREMENTS

For the BM78 module, due to limited module size, the NCC mark and ID are displayed in the data sheet and/or packaging and cannot be displayed on the module label:

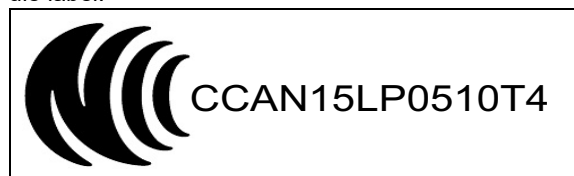

For the BM78 ROM module, due to limited module size, the NCC mark and ID are displayed in the data sheet and/or packaging and cannot be displayed on the module label:

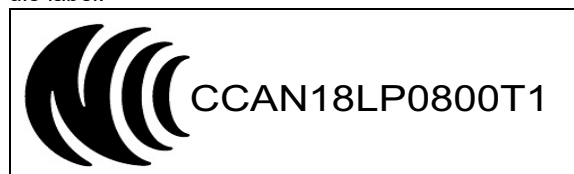

The user's manual must contain below warning (for RF device) in traditional Chinese:

注意！

依據 低功率電波輻射性電機管理辦法

BM78

第十二條 經型式認證合格之低功率射頻電機，非經許可，

公司、商號或使用者均不得擅自變更頻率、加大功率或變更原設計

之特性及功能。

第十四條 低功率射頻電機之使用不得影響飛航安全及干擾合法通信；

經發現有干擾現象時，應立即停用，並改善至無干擾時方得繼續使用。

前項合法通信，指依電信規定作業之無線電信。

低功率射頻電機須忍受合法通信或工業、科學及醫療用電波輻射性

電機設備之干擾。

A.6.2 HELPFUL WEB SITES

National Communications Commission (NCC):
<http://www.ncc.gov.tw>

A.7 China

The BM78/BM78 ROM module has received certification of conformity in accordance with the China MIIT Notice 2014-01 of State Radio Regulation Committee (SRRC) certification scheme. Integration of this module into a final product does not require additional radio certification, provided installation instructions are followed and no modifications of the module are allowed.

A.7.1 LABELING AND USER INFORMATION REQUIREMENTS

The BM78 module is labeled with its own CMIIT ID as follows:

CMIIT ID: 2015DJ7133

When Host system is using an approved Full Modular Approval (FMA) radio: The host must bear a label containing the statement “This device contains SRRC approved Radio module CMIIT ID: 2015DJ7133”.

The BM78 ROM module is labeled with its own CMIIT ID as follows:

CMIIT ID: 2018DJ3812

When Host system is using an approved Full Modular Approval (FMA) radio: The host must bear a label containing the statement “This device contains SRRC approved Radio module CMIIT ID: 2018DJ3812”.

A.8 Other Regulatory Information

- For information on the other countries jurisdictions covered, refer to the <http://www.microchip.com/design-centers/wireless-connectivity>.
- Should other regulatory jurisdiction certification be required by the customer, or the customer need to recertify the module for other reasons, contact Microchip for the required utilities and documentation.

APPENDIX B: REVISION HISTORY

Revision A (January 2016)

This is the initial released version of this document.

Revision B (April 2019)

This revision includes the following changes and minor updates to text and formatting, which were incorporated throughout the document.

TABLE B-1: MAJOR SECTION UPDATES

Section	Update Description
Document	Updated Bluetooth version from 4.2 to 5.0.
“Features”	<ul style="list-style-type: none"> Updated certification information. Updated Figure 1.
“Data Throughput”	Updated Kbytes/s.
1.0 “System Overview”	Updated Table 1-1 , Figure 1-1 and Figure 1-3 .
2.0 “Application Information”	Added Table 2-3 . Updated Table 2-2 , Figure 2-1 and Figure 2-8 .
3.0 “Operating Modes”	Updated this section.
4.0 “Electrical Characteristics”	Updated Storage temperature.
6.0 “Physical Dimensions”	Updated Figure 6-1 , Figure 6-2 , Figure 6-4 and Figure 6-5 .
8.0 “Module Placement Guidelines”	Updated Figure 8-1 .
9.0 “Ordering Information”	Updated Table 9-1 with certification information and added two part numbers.
Appendix A: “Certification Notices”	Updated this section.

BM78

NOTES:

THE MICROCHIP WEBSITE

Microchip provides online support via our WWW site at www.microchip.com. This website is used as a means to make files and information easily available to customers. Accessible by using your favorite Internet browser, the website contains the following information:

- **Product Support** – Data sheets and errata, application notes and sample programs, design resources, user's guides and hardware support documents, latest software releases and archived software
- **General Technical Support** – Frequently Asked Questions (FAQ), technical support requests, online discussion groups, Microchip consultant program member listing
- **Business of Microchip** – Product selector and ordering guides, latest Microchip press releases, listing of seminars and events, listings of Microchip sales offices, distributors and factory representatives

CUSTOMER CHANGE NOTIFICATION SERVICE

Microchip's customer notification service helps keep customers current on Microchip products. Subscribers will receive e-mail notification whenever there are changes, updates, revisions or errata related to a specified product family or development tool of interest.

To register, access the Microchip website at www.microchip.com. Under "Support", click on "Customer Change Notification" and follow the registration instructions.

CUSTOMER SUPPORT

Users of Microchip products can receive assistance through several channels:

- Distributor or Representative
- Local Sales Office
- Field Application Engineer (FAE)
- Technical Support

Customers should contact their distributor, representative or Field Application Engineer (FAE) for support. Local sales offices are also available to help customers. A listing of sales offices and locations is included in the back of this document.

Technical support is available through the website at: <http://microchip.com/support>

BM78

NOTES:

Note the following details of the code protection feature on Microchip devices:

- Microchip products meet the specification contained in their particular Microchip Data Sheet.
- Microchip believes that its family of products is one of the most secure families of its kind on the market today, when used in the intended manner and under normal conditions.
- There are dishonest and possibly illegal methods used to breach the code protection feature. All of these methods, to our knowledge, require using the Microchip products in a manner outside the operating specifications contained in Microchip's Data Sheets. Most likely, the person doing so is engaged in theft of intellectual property.
- Microchip is willing to work with the customer who is concerned about the integrity of their code.
- Neither Microchip nor any other semiconductor manufacturer can guarantee the security of their code. Code protection does not mean that we are guaranteeing the product as “unbreakable.”

Code protection is constantly evolving. We at Microchip are committed to continuously improving the code protection features of our products. Attempts to break Microchip's code protection feature may be a violation of the Digital Millennium Copyright Act. If such acts allow unauthorized access to your software or other copyrighted work, you may have a right to sue for relief under that Act.

Information contained in this publication regarding device applications and the like is provided only for your convenience and may be superseded by updates. It is your responsibility to ensure that your application meets with your specifications. MICROCHIP MAKES NO REPRESENTATIONS OR WARRANTIES OF ANY KIND WHETHER EXPRESS OR IMPLIED, WRITTEN OR ORAL, STATUTORY OR OTHERWISE, RELATED TO THE INFORMATION, INCLUDING BUT NOT LIMITED TO ITS CONDITION, QUALITY, PERFORMANCE, MERCHANTABILITY OR FITNESS FOR PURPOSE. Microchip disclaims all liability arising from this information and its use. Use of Microchip devices in life support and/or safety applications is entirely at the buyer's risk, and the buyer agrees to defend, indemnify and hold harmless Microchip from any and all damages, claims, suits, or expenses resulting from such use. No licenses are conveyed, implicitly or otherwise, under any Microchip intellectual property rights unless otherwise stated.

Microchip received ISO/TS-16949:2009 certification for its worldwide headquarters, design and wafer fabrication facilities in Chandler and Tempe, Arizona; Gresham, Oregon and design centers in California and India. The Company's quality system processes and procedures are for its PIC® MCUs and dsPIC® DSCs, KEELOQ® code hopping devices, Serial EEPROMs, microperipherals, nonvolatile memory and analog products. In addition, Microchip's quality system for the design and manufacture of development systems is ISO 9001:2000 certified.

**QUALITY MANAGEMENT SYSTEM
CERTIFIED BY DNV
= ISO/TS 16949 =**

Trademarks

The Microchip name and logo, the Microchip logo, AnyRate, AVR, AVR logo, AVR Freaks, BitCloud, chipKIT, chipKIT logo, CryptoMemory, CryptoRF, dsPIC, FlashFlex, flexPWR, Helder, JukeBlox, KeeLoq, Klear, LANCheck, LINK MD, maXStylus, maXTouch, MediaLB, megaAVR, MOST, MOST logo, MPLAB, OptoLyzer, PIC, picoPower, PICSTART, PIC32 logo, Prochip Designer, QTouch, SAM-BA, SpyNIC, SST, SST Logo, SuperFlash, tinyAVR, UNI/O, and XMEGA are registered trademarks of Microchip Technology Incorporated in the U.S.A. and other countries.

ClockWorks, The Embedded Control Solutions Company, EtherSynch, Hyper Speed Control, HyperLight Load, IntellIMOS, mTouch, Precision Edge, and Quiet-Wire are registered trademarks of Microchip Technology Incorporated in the U.S.A.

Adjacent Key Suppression, AKS, Analog-for-the-Digital Age, Any Capacitor, AnyIn, AnyOut, BodyCom, CodeGuard, CryptoAuthentication, CryptoAutomotive, CryptoCompanion, CryptoController, dsPICDEM, dsPICDEM.net, Dynamic Average Matching, DAM, ECAN, EtherGREEN, In-Circuit Serial Programming, ICSP, INICnet, Inter-Chip Connectivity, JitterBlocker, KlearNet, KlearNet logo, memBrain, Mindi, MiWi, motorBench, MPASM, MPF, MPLAB Certified logo, MPLIB, MPLINK, MultiTRAK, NetDetach, Omniscient Code Generation, PICDEM, PICDEM.net, PICKit, PICtail, PowerSmart, PureSilicon, QMatrix, REAL ICE, Ripple Blocker, SAM-ICE, Serial Quad I/O, SMART-I.S., SQI, SuperSwitcher, SuperSwitcher II, Total Endurance, TSHARC, USBCheck, VariSense, ViewSpan, WiperLock, Wireless DNA, and ZENA are trademarks of Microchip Technology Incorporated in the U.S.A. and other countries.

SQTP is a service mark of Microchip Technology Incorporated in the U.S.A.

Silicon Storage Technology is a registered trademark of Microchip Technology Inc. in other countries.

GestIC is a registered trademark of Microchip Technology Germany II GmbH & Co. KG, a subsidiary of Microchip Technology Inc., in other countries.

All other trademarks mentioned herein are property of their respective companies.

© 2018, Microchip Technology Incorporated, All Rights Reserved.
ISBN: 978-1-5224-4418-3



MICROCHIP

Worldwide Sales and Service

AMERICAS

Corporate Office
2355 West Chandler Blvd.
Chandler, AZ 85224-6199
Tel: 480-792-7200
Fax: 480-792-7277
Technical Support:
<http://www.microchip.com/support>
Web Address:
www.microchip.com

Atlanta

Duluth, GA
Tel: 678-957-9614
Fax: 678-957-1455

Austin, TX

Tel: 512-257-3370

Boston

Westborough, MA
Tel: 774-760-0087
Fax: 774-760-0088

Chicago

Itasca, IL
Tel: 630-285-0071
Fax: 630-285-0075

Dallas

Addison, TX
Tel: 972-818-7423
Fax: 972-818-2924

Detroit

Novi, MI
Tel: 248-848-4000

Houston, TX

Tel: 281-894-5983

Indianapolis

Noblesville, IN
Tel: 317-773-8323
Fax: 317-773-5453
Tel: 317-536-2380

Los Angeles

Mission Viejo, CA
Tel: 949-462-9523
Fax: 949-462-9608
Tel: 951-273-7800

Raleigh, NC

Tel: 919-844-7510

New York, NY

Tel: 631-435-6000

San Jose, CA

Tel: 408-735-9110
Tel: 408-436-4270

Canada - Toronto

Tel: 905-695-1980
Fax: 905-695-2078

ASIA/PACIFIC

Australia - Sydney
Tel: 61-2-9868-6733

China - Beijing
Tel: 86-10-8569-7000

China - Chengdu
Tel: 86-28-8665-5511

China - Chongqing
Tel: 86-23-8980-9588

China - Dongguan
Tel: 86-769-8702-9880

China - Guangzhou
Tel: 86-20-8755-8029

China - Hangzhou
Tel: 86-571-8792-8115

China - Hong Kong SAR
Tel: 852-2943-5100

China - Nanjing
Tel: 86-25-8473-2460

China - Qingdao
Tel: 86-532-8502-7355

China - Shanghai
Tel: 86-21-3326-8000

China - Shenyang
Tel: 86-24-2334-2829

China - Shenzhen
Tel: 86-755-8864-2200

China - Suzhou
Tel: 86-186-6233-1526

China - Wuhan
Tel: 86-27-5980-5300

China - Xian
Tel: 86-29-8833-7252

China - Xiamen
Tel: 86-592-2388138

China - Zhuhai
Tel: 86-756-3210040

ASIA/PACIFIC

India - Bangalore
Tel: 91-80-3090-4444

India - New Delhi
Tel: 91-11-4160-8631

India - Pune
Tel: 91-20-4121-0141

Japan - Osaka
Tel: 81-6-6152-7160

Japan - Tokyo
Tel: 81-3-6880-3770

Korea - Daegu
Tel: 82-53-744-4301

Korea - Seoul
Tel: 82-2-554-7200

Malaysia - Kuala Lumpur
Tel: 60-3-7651-7906

Malaysia - Penang
Tel: 60-4-227-8870

Philippines - Manila
Tel: 63-2-634-9065

Singapore
Tel: 65-6334-8870

Taiwan - Hsin Chu
Tel: 886-3-577-8366

Taiwan - Kaohsiung
Tel: 886-7-213-7830

Taiwan - Taipei
Tel: 886-2-2508-8600

Thailand - Bangkok
Tel: 66-2-694-1351

Vietnam - Ho Chi Minh
Tel: 84-28-5448-2100

EUROPE

Austria - Wels
Tel: 43-7242-2244-39
Fax: 43-7242-2244-393

Denmark - Copenhagen
Tel: 45-4450-2828
Fax: 45-4485-2829

Finland - Espoo
Tel: 358-9-4520-820

France - Paris
Tel: 33-1-69-53-63-20
Fax: 33-1-69-30-90-79

Germany - Garching
Tel: 49-8931-9700

Germany - Haan
Tel: 49-2129-3766400

Germany - Heilbronn
Tel: 49-7131-67-3636

Germany - Karlsruhe
Tel: 49-721-625370

Germany - Munich
Tel: 49-89-627-144-0
Fax: 49-89-627-144-44

Germany - Rosenheim
Tel: 49-8031-354-560

Israel - Ra'anana
Tel: 972-9-744-7705

Italy - Milan
Tel: 39-0331-742611
Fax: 39-0331-466781

Italy - Padova
Tel: 39-049-7625286

Netherlands - Drunen
Tel: 31-416-690399
Fax: 31-416-690340

Norway - Trondheim
Tel: 47-7288-4388

Poland - Warsaw
Tel: 48-22-3325737

Romania - Bucharest
Tel: 40-21-407-87-50

Spain - Madrid
Tel: 34-91-708-08-90
Fax: 34-91-708-08-91



Sweden - Gothenberg
Tel: 46-31-704-60-40

Sweden - Stockholm
Tel: 46-8-5090-4654

UK - Wokingham
Tel: 44-118-921-5800
Fax: 44-118-921-5820

Looking for pricing, stock, or lifecycle information?

Click below to explore more details on WIN SOURCE:

-  [View BM78SPPS5MC2-0002AA on WIN SOURCE](#)
-  [Microchip Technology](#) Information

Optimize Your Supply Chain with WIN SOURCE Solutions

-  Global Sourcing Solution
-  Obsolete Management
-  Cost Control Management
-  Shortage Management
-  Alternative Solution
-  Excess Inventory Management