



THE DATASHEET OF TPIC2030DBTRG4



TPIC2030 Serial I/F Controlled 7-Channel Motor-Driver With 1-Channel Step Down Regulator

1 Features

- Serial Peripheral Interface
 - Maximum Read/Write 35 MHz
 - 3.3-V Digital I/O
- Actuator and Motor Driver
 - PWM Control With H-Bridge Output
 - Focus / Tracking / Tilt Actuator Driver With 12-Bit DAC Control
 - Sled Motor Drivers With Current Mode, 10-Bit DAC Control
 - Load Driver With 12-Bit DAC Control
 - End Position Sensing for Sled Without Position Sensor
- Spindle Motor Driver
 - Integrated Spindle Current Sense Resistor
 - Sensor-Less: Rotor Position Sense by Motor BEMF
 - 12-Bit Spindle DAC
 - Quick Stop by Automatic Controlled Brake (Auto Short Brake)
 - LS Mode: Restricted to 25% of Normal Speed
- On-Chip Thermometer (15°C to 165°C/1.2°C)
- Software Controlled Switch for LED Driver With 0.1-A OCP
- Switch
 - CSW: Low $R_{DS(ON)}$ Current Switch With Selectable OCP Limit (Supposing Use <0.2 A)
 - LED: Software Control Current Output Port With 0.1-A OCP
- DC-DC Converter
 - Pin Selectable Conversion Voltage 1.0 V/ 1.2 V/ 1.5 V/ 3.3 V (or Disable)
 - Improved Efficiency at Low Current With Discontinuous Regulation Mode
- Protection
 - Individual Thermal Protect Circuit on LED/CSW, Switch, DCDC Converter, SPM, and Actuator
 - Overcurrent Protection
 - Undervoltage Lockout (UVLO) and Overvoltage Protection (OVP)

2 Applications

- DVD Player
- CD Player
- Optical Disk Drive

3 Description

TPIC2030 is very-low noise type motor driver IC suitable for slim or ultra-slim DVD reader/writer. The integrated current sense resistance for the spindle motor reduces cost and board area in designs. The TPIC2030 is an integrated solution for driving the spindle motor, sled motor, load motor, and Focus / Tracking / Tilt actuators in an optical disk drive. It also integrates a synchronous DC-DC converter to supply 1.0 or 3.3 V. The discontinuous mode regulation feature on the DC-DC converter improves efficiency at low power consumption.

Device Information⁽¹⁾

PART NUMBER	PACKAGE	BODY SIZE (NOM)
TPIC2030DBT	TSSOP (44)	11.10 mm x 4.40 mm

(1) For all available packages, see the orderable addendum at the end of the data sheet.

Simplified Block Diagram

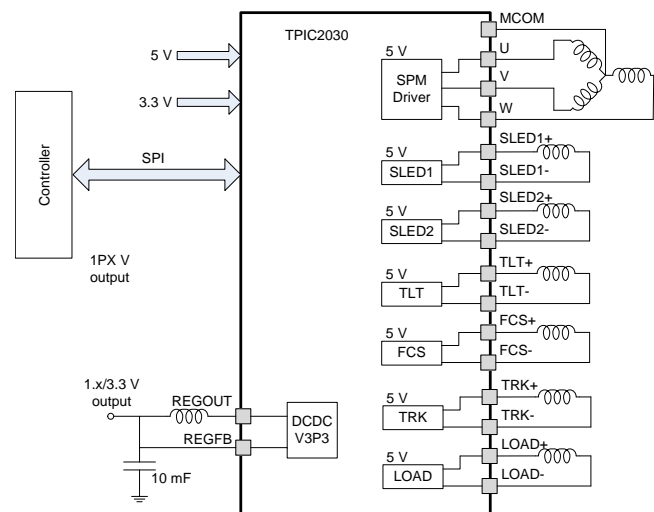

Table of Contents

1 Features	1	7.17 Serial Port I/F Write Timing Requirements	11
2 Applications	1	7.18 Serial I/F Read Timing Requirements	11
3 Description	1	7.19 Typical Characteristics	12
4 Revision History	2	8 Detailed Description	13
5 Description (continued)	3	8.1 Overview	13
6 Pin Configuration and Functions	3	8.2 Functional Block Diagram	14
7 Specifications	5	8.3 Feature Description	15
7.1 Absolute Maximum Ratings	5	8.4 Device Functional Modes	21
7.2 ESD Ratings	5	8.5 Programming	24
7.3 Recommended Operating Conditions	5	8.6 Register Maps	26
7.4 Thermal Information	6	9 Application and Implementation	43
7.5 Electrical Characteristics – Common Part	7	9.1 Application Information	43
7.6 Electrical Characteristics – Charge Pump Part	7	9.2 Typical Application	52
7.7 Electrical Characteristics – DC-DC Converter	8	10 Power Supply Recommendations	54
7.8 Electrical Characteristics – Spindle Motor Driver Part	8	11 Layout	54
7.9 Electrical Characteristics – Sled Motor Driver Part ...	9	11.1 Layout Guidelines	54
7.10 Electrical Characteristics – Focus/ Tilt/Tracking/Driver Part	9	11.2 Layout Example	54
7.11 Electrical Characteristics – Load Driver Part	9	12 Device and Documentation Support	55
7.12 Electrical Characteristics – Current Switch Part	9	12.1 Device Support	55
7.13 Electrical Characteristics – LED Switch Part	10	12.2 Community Resources	55
7.14 Electrical Characteristics – Thermometer Part	10	12.3 Trademarks	55
7.15 Electrical Characteristics – Actuator Protection	10	12.4 Electrostatic Discharge Caution	55
7.16 Electrical Characteristics – Serial Port Voltage Levels	10	12.5 Glossary	55
		13 Mechanical, Packaging, and Orderable Information	55

4 Revision History

DATE	REVISION	NOTES
December 2015	*	Initial release.

5 Description (continued)

Sensorless control using BEMF allows for self-starting and low-noise operation of the spindle motor without requiring external sensors. In addition, the TPIC2030 has many built-in protection features including: spindle driver output current limiting, thermal shutdown, sled-end detection, and power-reset circuit. It also integrates a thermometer to measure IC temperature.

6 Pin Configuration and Functions

**DBT Package
44-Pin TSSOP
Top View**

1	PGND_1	LOAD-	44
2	PGND_SW	LOAD+	43
3	REGOUT	SLED2-	42
4	P5V_SW	SLED2+	41
5	REGFB	SLED1-	40
6	SIOV	SLED1+	39
7	SWR_VSEL1	LEDO	38
8	SWR_VSEL2	CSWO	37
9	SSZ	MCOM	36
10	SCLK	P5V_1	35
11	SIMO	P5V_SPM	34
12	SOMI	W	33
13	XMUTE	U	32
14	XFG	V	31
15	XRESET	PGND_SPM	30
16	GPOUT	TRK-	29
17	CP1	TRK+	28
18	CP2	FCS-	27
19	CP3	FCS+	26
20	AGND	TLT-	25
21	CV3P3A	TLT+	24
22	P5V_2	PGND_2	23

Pin Functions

PIN		I/O ⁽¹⁾	DESCRIPTION
NO.	NAME		
1	PGND_1	PS	GND terminal
2	PGND_SW	PS	GND terminal for DC-DC converters
3	REGOUT	O	DC-DC converter switching output. Possible GPOUT pin in disable DC-DC
4	P5V_SW	PS	Power supply terminal for DC-DC converters
5	REGFB	I	Feedback input terminal for DC-DC converter
6	SIOV	PS	Power supply terminal for serial port typical 3.3 V
7	SWR_VSEL1	I	Setting DC-DC converter output voltage
8	SWR_VSEL2	I	Setting DC-DC converter output voltage setting
9	SSZ	I	SIO slave select low active input terminal
10	SCLK	I	SIO serial clock input terminal
11	SIMO	I	SIO slave input master output terminal
12	SOMI	O	SIO slave output master input terminal
13	XMUTE	I	XMUTE input terminal to disable driver output
14	XFG	O	Motor speed signal output
15	XRESET	O	Power on reset output. Internally pulled up to SIOV
16	GPOUT	O	General-purpose output (test monitor)
17	CP1	MISC	Capacitance connection for charge pump
18	CP2	MISC	Capacitance connection for charge pump
19	CP3	MISC	Capacitance connection for charge pump
20	AGND	PS	Ground terminal for internal logic
21	CV3P3A	MISC	Capacitance terminal for internal 3.3-V regulator
22	P5V_2	PS	Power supply terminal
23	PGND_2	PS	GND terminal
24	TLT+	O	Tilt positive output terminal
25	TLT-	O	Tilt negative output terminal
26	FCS+	O	Focus positive output terminal
27	FCS-	O	Focus negative output terminal
28	TRK+	O	Tracking positive output terminal
29	TRK-	O	Tracking negative output terminal
30	PGND_SPM	PS	GND terminal for spindle driver
31	V	O	V phase output terminal for spindle motor
32	U	O	U phase output terminal for spindle motor
33	W	O	W phase output terminal for spindle motor
34	P5V_SPM	PS	Power supply terminal for Spindle driver
35	P5V_1	PS	Power supply terminal
36	MCOM	I	Motor center tap connection
37	CSWO	O	Power switch output for 5V OEIC in OPU
38	LEDO	O	LED output terminal
39	SLED1+	O	Sled1 positive output terminal
40	SLED1-	O	Sled1 negative output terminal
41	SLED2+	O	Sled2 positive output terminal
42	SLED2-	O	Sled2 negative output terminal
43	LOAD+	O	Load positive output terminal
44	LOAD-	O	Load negative output terminal

(1) I: Input; O: Output; PS: Power; MISC: Miscellaneous

7 Specifications

7.1 Absolute Maximum Ratings

over operating free-air temperature range (unless otherwise noted)⁽¹⁾

	MIN	MAX	UNIT
+ 5 V supply voltage P5V, P5V_SW, P5V_SPM		6	V
Voltage		7	V
Spindle output current		1.0	A
Spindle output peak current (PW ≤ 2 ms, Duty ≤ 30%)		2.5	A
Current		0.8	A
Focus/tilt/tracking driver output peak current		1.5	A
Current		0.8	A
Input/output voltage	-0.3	V _{CC} + 0.3 V	V
Power dissipation		1438	mW
Operating temperature	-20	75	°C
T _{stg} Storage temperature	-50	150	°C

(1) Stresses beyond those listed under *Absolute Maximum Ratings* may cause permanent damage to the device. These are stress ratings only, which do not imply functional operation of the device at these or any other conditions beyond those indicated under *Recommended Operating Conditions*. Exposure to absolute-maximum-rated conditions for extended periods may affect device reliability.

7.2 ESD Ratings

		VALUE	UNIT
V _(ESD) Electrostatic discharge	Human-body model (HBM), per ANSI/ESDA/JEDEC JS-001 ⁽¹⁾	±2000	V
	Charged-device model (CDM), per JEDEC specification JESD22-C101 ⁽²⁾	±500	

(1) JEDEC document JEP155 states that 500-V HBM allows safe manufacturing with a standard ESD control process.

(2) JEDEC document JEP157 states that 250-V CDM allows safe manufacturing with a standard ESD control process.

7.3 Recommended Operating Conditions

over operating free-air temperature range (unless otherwise noted)

	MIN	NOM	MAX	UNIT
P5V Operating supply voltage(Apply for P5V)	4.5	5.0	5.5	V
V _{SIOV} SIOV voltage	3.0	3.3	3.6	V
V _{SIFH} XMUTE, SIMO, SSZ, SCLK pin H level input voltage range			SIOV + 0.2	V
V _{SIFL} XMUTE, SIMO, SSZ, SCLK pin L level input voltage range	-0.2		0.8	V
V _{IHB} SWR_VSEL1, SWR_VSEL2 pin H level input voltage	2.2		P5V + 0.1	V
V _{ILB} SWR_VSEL1, SWR_VSEL2 pin L level input voltage range	-0.1		0.8	V
V _{disRFB} REGFB input level for DC-DC converter disable	P5V - 0.1	P5V	P5V + 0.1	V
I _{SPMOA} Spindle output average current (U, V, W total)			700	mA
I _{SPMO} Spindle output current			700	mA
I _{SLDOA} Sled output average current			400	mA
I _{Ld1Px} DC-DC converter load current 1.x V			700	mA
I _{Ld3P3} DC-DC converter load current 3.3 V			500	mA
I _{ACTOA} Focus / tracking / tilt / loading output average current			400	mA
I _{LEDOA} LED output average current			50	mA
I _{CSWOA} CSWO output average current			200	mA
F _{ck} SCLK frequency	30	33.8688	35	MHz
T _O Operating	-20	25	75	°C

7.4 Thermal Information

THERMAL METRIC ⁽¹⁾		TPIC2030	
		DBT (TSSOP)	
		TBD PINS	
			UNIT
$R_{\theta JA}$	Junction-to-ambient thermal resistance ⁽²⁾	71.9	°C/W
$R_{\theta JC(top)}$	Junction-to-case (top) thermal resistance	19.1	°C/W
$R_{\theta JB}$	Junction-to-board thermal resistance	34.3	°C/W
ψ_{JT}	Junction-to-top characterization parameter	0.5	°C/W
ψ_{JB}	Junction-to-board characterization parameter	33.9	°C/W
$R_{\theta JC(bot)}$	Junction-to-case (bottom) thermal resistance	N/A	°C/W

(1) For more information about traditional and new thermal metrics, see the *Semiconductor and IC Package Thermal Metrics* application report, [SPRA953](#).

(2) The JEDEC specification low K (1 s) board design used to derive this data

7.5 Electrical Characteristics – Common Part

over recommended operating free-air temperature range; (P5V ≈ 4.5 to 5.5 V, T_A ≈ –20°C to 75°C, unless otherwise noted)

PARAMETER		TEST CONDITIONS	MIN	TYP	MAX	UNIT
ISTBY	Standby supply current	REGFB = P5V, XSLEEP = L			0.2	mA
VCV3	CV3P3 output voltage	Iload = 25 mA, REGFB < 3.7 V	2.97	3.3	3.63	V
RXM	XMUTE pulldown resistor		80	200	320	kΩ
RSW1	SWR_VSEL1 pulldown resistor		80	200	320	kΩ
RSW2	SWR_VSEL2 pulldown resistor		80	200	320	kΩ
RXRST	XRESET pullup resistor		13.2	33	52.8	kΩ
VXRSTL	XRESET low level output voltage	SIOV = 3.3 V, IOL = –100 μA			0.3	V
TPOR	Power on reset delay		15	20	25	ms
RXFG	XFG output resistor		100	200	300	Ω
VXFGH	XFG high level output voltage	SIOV = 3.3 V, XSLEEP = 1, IOH = 100 μA	SIOV – 0.3			V
VXFGL	XFG low level output voltage	SIOV = 3.3 V, XSLEEP = 1, IOL = –100 μA			0.3	V
RGPO	GPOUT output resistor		100	200	300	Ω
VGPOH	GPOUT high level output voltage	SIOV = 3.3 V, XSLEEP = 1, GPOUT_ENA = 1, GPOUT_HL = 1, IOH = 100 μA	SIOV – 0.3			V
VGPOL	GPOUT low level output voltage	SIOV = 3.3 V, XSLEEP = 1, GPOUT_ENA = 1, GPOUT_HL = 0, IOH = 100 μA			0.3	V
tTSD	Thermal protect on temperature	Design specified value	135	150	165	°C
hytTSD	Thermal protect hys temperature		5	15	25	°C
Vonvcc	P5V Reset on voltage		3.4	3.65	3.9	V
Voffvcc	P5V Reset off voltage		3.6	3.85	4.1	V
VonCV3	CV3P3 reset on voltage		2.4	2.6	2.8	V
VoffCV3	CV3P3 reset off voltage		2.5	2.7	2.9	V
VonSIO	SIOV reset on voltage		2.3	2.5	2.7	V
VoffSIO	SIOV reset off voltage		2.4	2.6	2.8	V
VovpspmOn	OVP detection voltage (spindle) ⁽¹⁾		6.0	6.2	6.5	V
VovpspmOff	OVP release voltage (spindle) ⁽¹⁾		5.8	6.0	6.3	V
VovpSpmHys	OVP voltage hysteresis (spindle) ⁽¹⁾		110	230	350	mV
VovpOn	OVP detection voltage (except spindle) ⁽¹⁾		6.3	6.5	6.8	V
VovpOff	OVP release voltage (except spindle) ⁽¹⁾		6.1	6.3	6.6	V
VovpHys	OVP voltage hysteresis (except Spindle) ⁽¹⁾		120	240	360	mV

(1) Those are value as protection functions only, and stress beyond those listed under *Recommended Operating Conditions* may cause permanent damage to the device.

7.6 Electrical Characteristics – Charge Pump Part

over recommended operating free-air temperature range; (P5V ≈ 4.5 to 5.5 V, T_A ≈ –20°C to 75°C, unless otherwise noted)

PARAMETER		TEST CONDITIONS	MIN	TYP	MAX	UNIT
FCHGP	Frequency	XSLEEP = 1	132.6	156	179.4	kHz
VCHGP	Output Voltage	Ccp1 = Ccp3 = 0.1 μF IO = –1 mA	7.76	9.7	11.64	V

7.7 Electrical Characteristics – DC-DC Converter

 over recommended operating free-air temperature range; (P5V ≈ 4.5 to 5.5 V, T_A ≈ –20°C to 75°C, unless otherwise noted)

PARAMETER		TEST CONDITIONS	MIN	TYP	MAX	UNIT
Rds1pxH	High Side FET RDSON	REGFB = 0 V REGOUT + 100 mA, +300 mA		0.42	0.62	Ω
Rds1pxL	Low Side FET RDSON	REGFB = 1.2 V REGOUT – 100 mA, –300 mA		0.2	0.4	Ω
VO1p0	Output Voltage(1p0V)	[SWR_VSEL2, SWR_VSEL1] = 10	0.95	1.0	1.05	V
VO1p2	Output Voltage(1p2V)	[SWR_VSEL2, SWR_VSEL1] = 01	1.14	1.2	1.26	V
VO1p5	Output Voltage(1p5V)	[SWR_VSEL2, SWR_VSEL1] = 11	1.425	1.5	1.575	V
VO3p3	Output Voltage(3p3V)	[SWR_VSEL2, SWR_VSEL1] = 00	3.13	3.3	3.47	V
Tdly1p2	Soft start time	[SWR_VSEL2, SWR_VSEL1] = 01 From P5V reset off to target 90%	0.66	0.82	0.98	ms
RdsO1p2	Output Pull down transistor Rdson	REGFB = 1 V (at DC-DC enable)	616	880	1144	Ω
Fsw1px	Switching frequency		2.125	2.5	2.875	MHz
Vrston1px	Reset on voltage threshold level		75%	80%	85%	
Vrstoff1px	Reset off voltage threshold level		85%	90%	95%	
VrstHys	Reset off voltage threshold Hys		5%	10%	15%	
PSRRDCDC	PSRR ratio	P5V_SW = 5 V + 200 mVpp, I _O = 200 mA, F ≈ 100 kHz	26	–	–	dB
I _{ovc} DCDC	Overcurrent protective level ⁽¹⁾⁽²⁾	[SWR_VSEL2, SWR_VSEL1] ≠ 00 SWR_BSTAUTON = 0	1.3	1.85	2.4	A
		[SWR_VSEL2, SWR_VSEL1] = 00 SWR_BSTAUTON = 0	0.65	1.15	1.65	A
T _{mskovctpic}	mask time of over current protection ⁽¹⁾		0.7	1.0	1.3	ms

(1) Those are value as protection functions only, and stress beyond those listed under *Recommended Operating Conditions* may cause permanent damage to the device.

(2) These value may fall in low temperature at selecting auto discontinuous mode (SWR_BSTAUTON = 1)

7.8 Electrical Characteristics – Spindle Motor Driver Part

 over recommended operating free-air temperature range; (P5V ≈ 4.5 to 5.5 V, T_A ≈ –20°C to 75°C, unless otherwise noted)

PARAMETER		TEST CONDITIONS	MIN	TYP	MAX	UNIT
R _{ttl} SPM	Total output resistance High side + low side (IncldRcs)	I _{OUT} = 0.5 A		0.37	0.7	Ω
ResSPM	Resolution			12		bit
GnSPM	Gain	Magnification to 1.0 input	5.2	6.0	6.8	times
WidDZSPM	Spindle dead band	Forward	12h	52h	92h	
		Reverse	–92h	–52h	–12h	
WidDZSPMLS	Spindle dead band (LS mode)		–40h	0h	40h	
SPM _{Clim}	Current limit	SPM_RCOM_SEL = 00	801	890	979	mA
		SPM_RCOM_SEL = 01	882	980	1078	mA
		SPM_RCOM_SEL = 10	652	725	798	mA
		SPM_RCOM_SEL = 11	705	784	863	mA

7.9 Electrical Characteristics – Sled Motor Driver Part

over recommended operating free-air temperature range; (P5V ≈ 4.5 to 5.5 V, T_A ≈ –20°C to 75°C, unless otherwise noted)

PARAMETER		TEST CONDITIONS	MIN	TYP	MAX	UNIT
RttISLD	Total output resistance High side + low side	I _O = 0.5 A		0.8	1.2	Ω
ResSLD	Resolution			10		bit
WidDZSLD	input Dead band	Forward	2h	1Fh	60h	
		Reverse	–60h	–1Fh	–2h	
GnSLD	Sled current gain	P5V = 5 V R _L = 10 Ω, 2.2 mH VSLED = 7FFh	380	440	500	mA
VthEdetSLD	END_DET BEMF threshold voltage	SLEDENDTH<1:0> = 00	26	46	66	mV
		SLEDENDTH<1:0> = 01	42	82	122	mV
		SLEDENDTH<1:0> = 11	9	22	35	mV

7.10 Electrical Characteristics – Focus/ Tilt/Tracking/Driver Part

over recommended operating free-air temperature range; (P5V ≈ 4.5 to 5.5 V, T_A ≈ –20°C to 75°C, unless otherwise noted)

PARAMETER		TEST CONDITIONS	MIN	TYP	MAX	UNIT
RttIAct	Total output resistance High side + low side	I _O = 0.5 A		0.7	1.1	Ω
ResACT	Resolution			12		bit
VOfstACT	Each channel output offset voltage	DAC_code = 000h	–30	0	30	mV
VOfstDACT	Output offset voltage focus and tilt	DIFF_TLT = 1	–50	0	50	mV
GnDACT	Difference gain focus and tilt	DIFF_TLT = 1	–1	0	1	db
GnAct	Gain	magnification to 1.0 input	5.2	6	6.8	times

7.11 Electrical Characteristics – Load Driver Part

over recommended operating free-air temperature range; (P5V ≈ 4.5 to 5.5 V, T_A ≈ –20°C to 75°C, unless otherwise noted)

PARAMETER		TEST CONDITIONS	MIN	TYP	MAX	UNIT
RttILOD	Total output resistance High side + low side	I _O = 0.5 A		0.7	1.1	Ω
ResLOD	Resolution			12		bit
GnLOD	Gain	Magnification to 1.0 input	5.2	6	6.8	times
WidDZLOD	Dead band	Forward		20h		
		Reverse		–21h		
TocpLOD	Output 100% limit time	LOAD_05CH = 0	0.64	0.8	0.96	s
IocpLOD	Overcurrent protective Level	LOAD_05CH = 1 at Load_OCP_IUP = 0	120	240	360	mA
		LOAD_05CH = 1 at Load_OCP_IUP = 1	215	430	645	mA
DlyocpLOD	Overcurrent protection delay time	LOAD_05CH = 1	0.64	0.8	0.96	s

7.12 Electrical Characteristics – Current Switch Part

over recommended operating free-air temperature range; (P5V ≈ 4.5 to 5.5 V, T_A ≈ –20°C to 75°C, unless otherwise noted)

PARAMETER		TEST CONDITIONS	MIN	TYP	MAX	UNIT
RdsCSW	Rds(on)	I _O = 0.2 A		200	500	mΩ
lImltCSW	Current limit threshold level		0.25	0.5	0.75	A
ThICSW	Protection hold time		1.47	1.6	2.0	ms

7.13 Electrical Characteristics – LED Switch Part

 over recommended operating free-air temperature range; (P5V ≈ 4.5 to 5.5 V, T_A ≈ –20°C to 75°C, unless otherwise noted)

PARAMETER		TEST CONDITIONS	MIN	TYP	MAX	UNIT
RdsLED	Rds(on)	I _O = 10 mA		4.4	10	Ω
IlmtLED	Current limit threshold level	P5V = 5 V	0.055	0.1	0.145	A
ThLED	Protection hold time		0.35	0.4	0.66	ms

7.14 Electrical Characteristics – Thermometer Part

 over recommended operating free-air temperature range; (P5V ≈ 4.5 to 5.5 V, T_A ≈ –20°C to 75°C, unless otherwise noted)

PARAMETER		TEST CONDITIONS	MIN	TYP	MAX	UNIT
ResTEMP	Resolution			7		bit
TEMPrng	Temperature range	CHIPTEMP[6:0] = 00	8	15	22	°C
		CHIPTEMP[6:0] = 7Fh	155	165	175	
FTEMP	Update cycle		8	10	12	KHz

7.15 Electrical Characteristics – Actuator Protection

 over recommended operating free-air temperature range; (P5V ≈ 4.5 to 5.5 V, T_A ≈ –20°C to 75°C, unless otherwise noted)

PARAMETER		TEST CONDITIONS	MIN	TYP	MAX	UNIT
TintACTTEMP	Update cycle		21	26	31	ms

7.16 Electrical Characteristics – Serial Port Voltage Levels

 over recommended operating free-air temperature range; (P5V ≈ 4.5 to 5.5 V, T_A ≈ –20°C to 75°C, unless otherwise noted)

PARAMETER		TEST CONDITIONS	MIN	TYP	MAX	UNIT
SOMI	High-level output voltage, V _{OH}	I _{OH} = 1 mA	80 % SIOV			V
SOMI	Low-level output voltage, V _{OL}	I _{OL} = 1 mA			20% SIOV	V
SIMO	High-level input voltage, V _{IH}		70% SIOV			V
SIMO	Low level input voltage, V _{IL}				20% SIOV	V
SIMO	Input rise/fall time	10% → 90% SIOV			3.5	ns
SOMI	Output rise/fall time ⁽¹⁾	Cload = 30 pF, 10% 90% SIOV			10	ns
SCLK	Internal pulldown resistance		80	200	320	kΩ
SSZ	Internal pullup resistance		80	200	320	kΩ

(1) Specified by design

7.17 Serial Port I/F Write Timing Requirements

			MIN	NOM	MAX	UNIT
F_{ck}	SCLK clock frequency	SIOV = 3.3 V			35	MHz
t_{ckl}	SCLK low time		11			ns
t_{ckh}	SCLK high time		11			ns
t_{sens}	SSZ setup time		7			ns
t_{senh}	SSZ hold time		7			ns
t_{sl}	SSZ disable high time		11			ns
t_{ds}	SIMO setup time (Write)		7			ns
t_{dh}	SIMO hold time (Write)		7			ns

7.18 Serial I/F Read Timing Requirements

			MIN	NOM	MAX	UNIT
F_{ck}	SCLK clock frequency	SIOV = 3.3 V			35	MHz
t_{ckl}	SCLK low time		11			ns
t_{ckh}	SCLK high time		11			ns
t_{sens}	SSZ setup time		7			ns
t_{senh}	SSZ hold time		7			ns
t_{sl}	SSZ disable high time		11			ns
t_{ds}	SIMO setup time (Write)		7			ns
t_{dh}	SIMO hold time (Write)		7			ns
t_{rdly}	SOMI delay time (Read)	CLOAD = 10 pF, SIOV = 3.3 V	2		9	ns
t_{sendl}	SOMI hold time (Read)	CLOAD = 10 pF, SIOV = 3.3 V	2		9	ns
t_{rls}	SOMI release time (Read)	CLOAD = 10 pF, SIOV = 3.3 V From SSZ rise to SOMI HIZ	0		9	ns

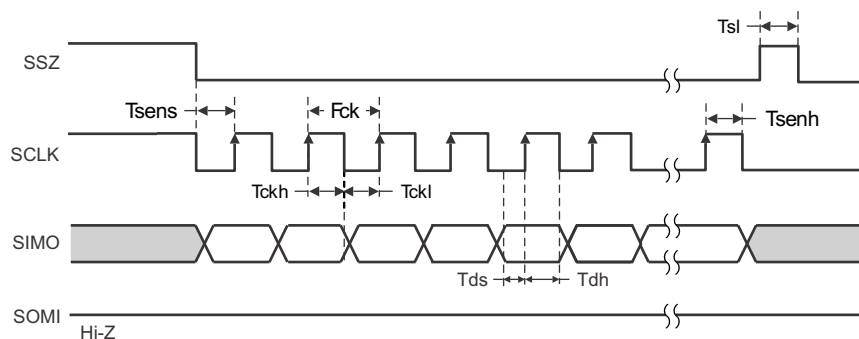

Figure 1. Serial Port Write Timing

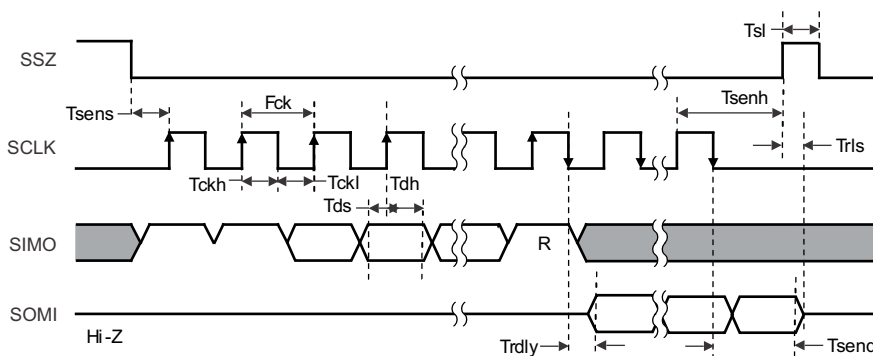
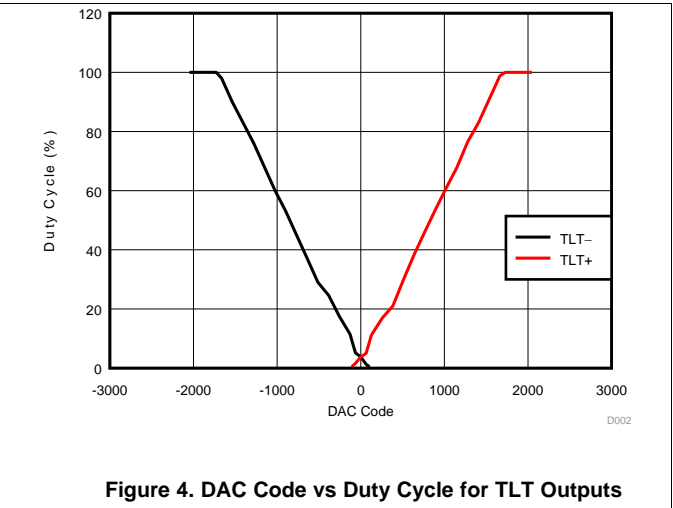
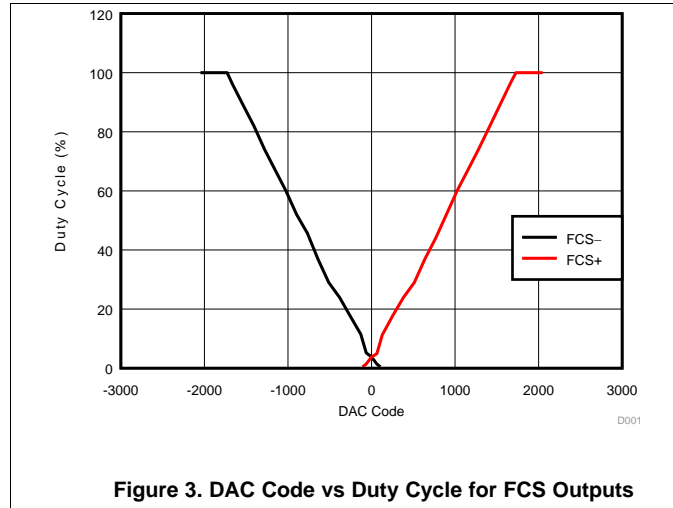

Figure 2. Serial Port Read Timings

7.19 Typical Characteristics



8 Detailed Description

8.1 Overview

TPIC2030 is low noise type motor driver IC suitable for 5V optical disk drives. The 7-channel driver IC controlled by serial I/F is optimum for driving a spindle motor, a sled motor (stepping motor applicable), a load motor, and Focus / Tracking / Tilt actuators. The integrated current sense resistance for spindle motor current measurement reduces drive system cost. The spindle motor driver part uses integrated sensorless logic to attain very low-noise operation during startup and runtime. By using BEMF feedback, external sensors, such as a Hall device, are not needed to carry out self-starting by the starting circuit or perform position detection. By using the efficient PWM drivers, low-power operation can be achieved by controlling the PWM outputs. Dead zone less control is possible for a Focus / Tracking / Tilt actuator driver. In addition, the spindle part output current limiting circuit, the thermal shut down circuit, and the sled end-detection circuit offer protection for all actuators and motors.

8.2 Functional Block Diagram

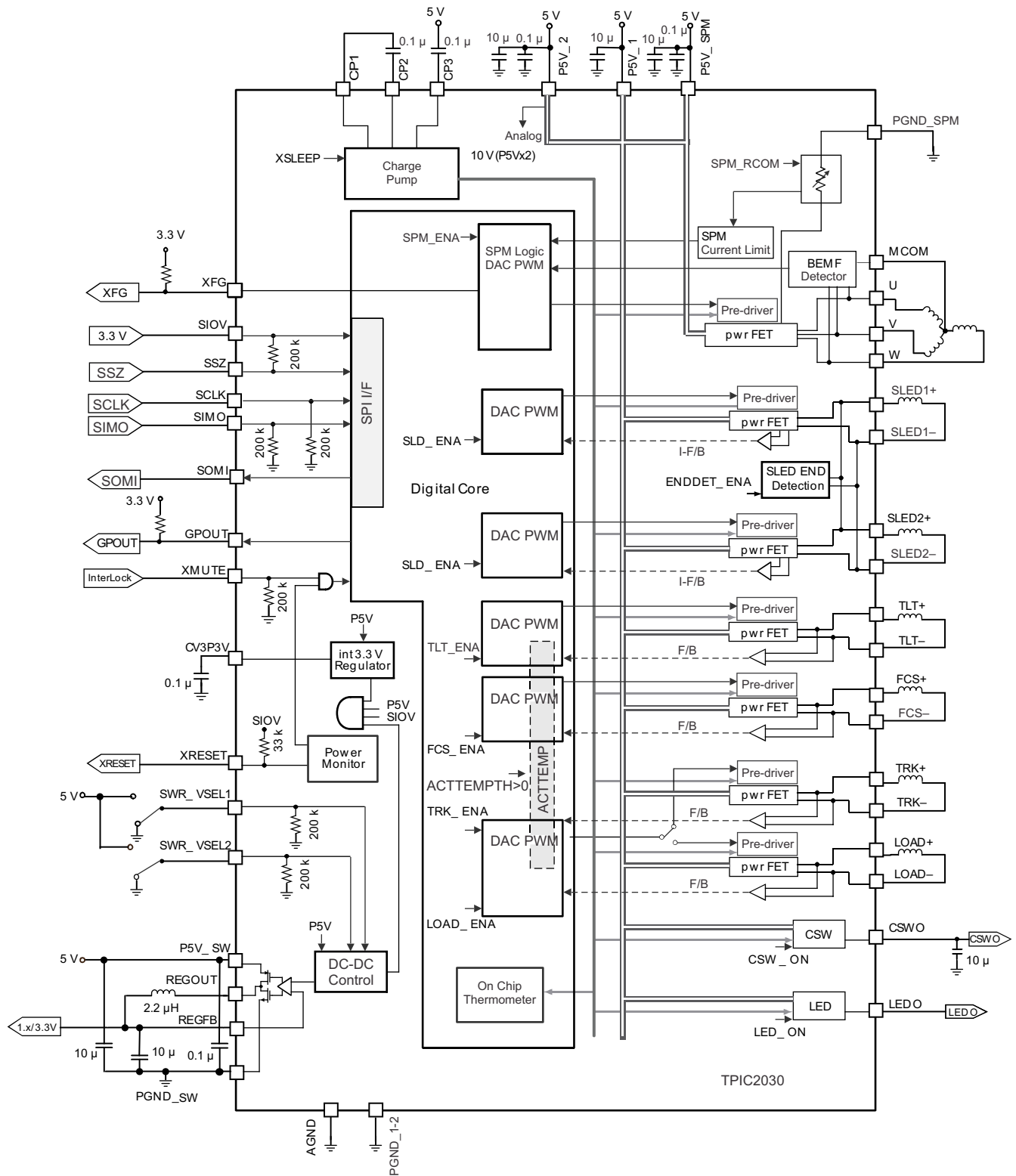

8.3 Feature Description

8.3.1 Protection Functions

TPIC2030 has five protection features, under voltage lock out (UVLO), over voltage protection (OVP), short circuit protection (SCP), thermal protection (TSD), and actuator temperature protection (ACTTIMER) in order to protect target equipment. A protect behavior differ by generated events.

8.3.1.1 Undervoltage Lockout (UVLO)

Power faults are reported in the UVLOMon register. Each UVLOMon bit will be initialized to zero upon a cold power up.

After a fault is detected the appropriate fault bit will be latched high. Writing to the RST_ERRFLG (REG77) will clear all UVLOMon bits. The power device faults and actions are summarized in [Table 1](#).

Table 1. Power Fault Monitor

FAULT TYPE	LATCHED REGISTER	XRESET	CRITERIA	SPM	ACTUATOR	DC-DC
P5V under voltage	UVLO_P5V	Yes	<3.7 V	Hi-Z	Hi-Z	REGOUT = Hi-Z REGFB = GND (enable DC-DC)
Internal 3.3 V under voltage	UVLO_INT3P3	Yes	<2.6 V	Hi-Z	Hi-Z	Hi-Z
DC-DC output under voltage	UVLO_SWR	Yes	<80%	Hi-Z	Hi-Z	
SIOV under voltage	UVLO_SIOV	Yes	<2.5 V	Hi-Z	Hi-Z	
P5V over voltage	OVP_P5V		>6.2 V	Brake	–	–
			>6.5 V	Hi-Z	Hi-Z	Hi-Z

8.3.1.2 Overvoltage Protection (OVP)

Over voltage protect function is aimed to protect the unit from the supplying hi-voltage.

When the supply voltage exceeds 6.5 V, all driver and DC-DC converter output goes Hi-Z. When the supply voltage falls below typical 6.2 V, (6.0 V for SPM) all output start to operate again. The OVP and POR (XRESET) function is not interlocking. However, DC-DC converter output falls by Hi-Z operations, output voltage falls to 80% then XRESET signal goes low.

Moreover, when power supply exceeds 6.2 V, especially SPM enter short brake mode. This operation is offered supposing a voltage rising by motor BEMF of the high velocity revolution.

This function is for insurance, so it can not assure that the device is safety in the condition. Because the absolute maximum ratings range of the supply voltage is 6 V. When this function works, the feed back terminals are not shorted to GND.

[Figure 5](#) shows the behavior of over voltage protection.

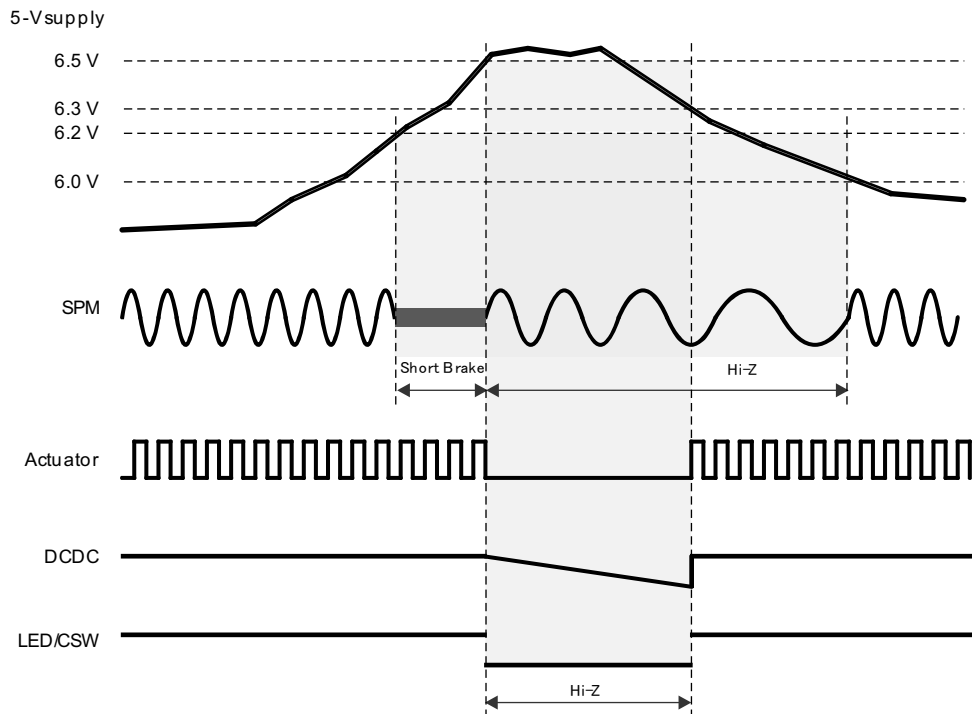

Figure 5. Overvoltage Protection

8.3.1.3 Overcurrent Protection (OCP)

The over current protect function serve to protect the device from break down by large current. The OCP is provided for four circuit blocks, and each threshold are on [Table 2](#).

Table 2. OCP Threshold

BLOCK	DETECTION CURRENT	MONITOR TIME	PROTECTION TIME	LATCHED FLAG
DC-DC converter	1850 mA (1.x V) 1200 mA (3.3 V)	1 ms	Forever (P5V power recycle)	OCP_SWR
Load driver 1 channel	Continue 100% duty	800 ms	forever	OCP_LOAD
Load driver 0.5 channel	240 mA	800 ms	forever	OCP_LOAD
LED driver	100 mA	20 μ s	0.4 ms	OCP_LED
CSW driver	500 mA	20 μ s	1.6 ms	OCP_CSW

When the large current is detected on each block, device put the output FET to Hi-Z.

The amounts of currents and time have specified the detection threshold for every circuit block.

When OCP occurs, it returns automatically after expiring set Hi-Z period. However, it restricts, the POR is performed at OCP for DC-DC converter. It keeps XRESET = L and does not return forever. It's necessary power ON/OFF actuation in order to make it release.

OCPERR (REG7F) and OCP flag (REG7B) are set at OCP detection.

8.3.1.3.1 OCP for DC-DC Converter

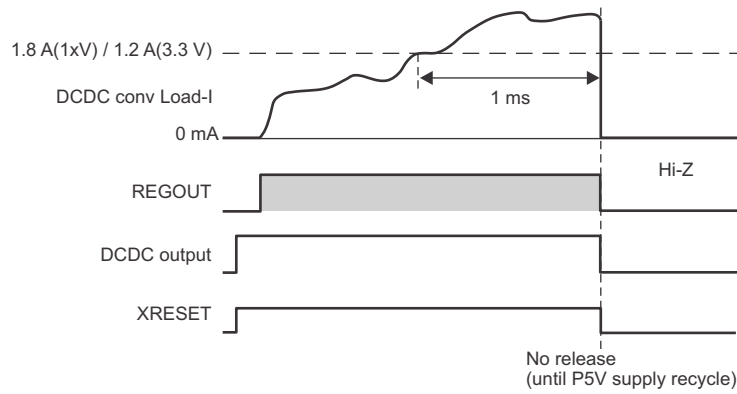

Figure 6. Overcurrent Protection DC-DC Converter

8.3.1.3.2 OCP for Load Driver

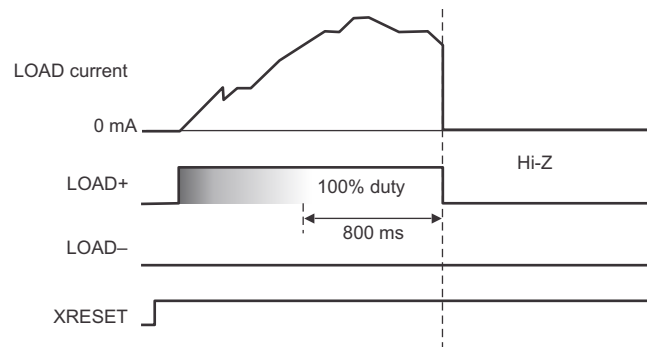

Figure 7. Overcurrent Protection Load 1-Channel

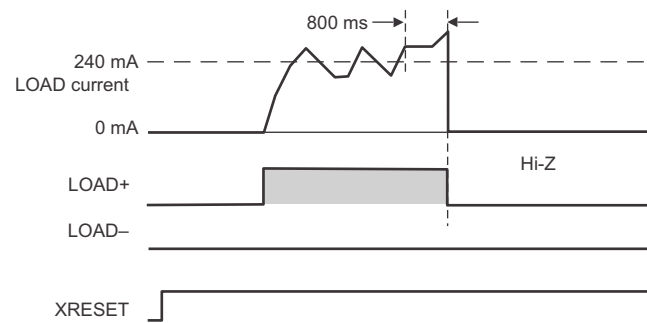

Figure 8. Overcurrent Protection Load 0.5-Channel

8.3.1.3.3 OCP for LED Driver

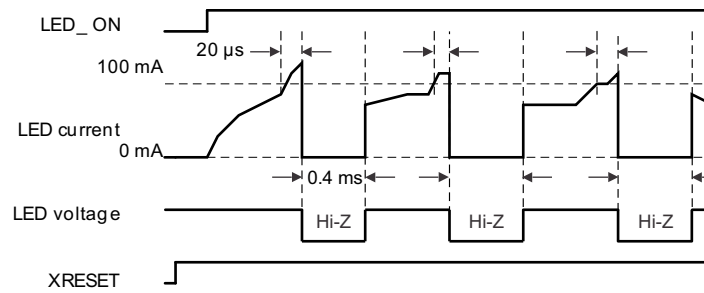

Figure 9. Overcurrent Protection LED Driver

8.3.1.3.4 OCP for CSW

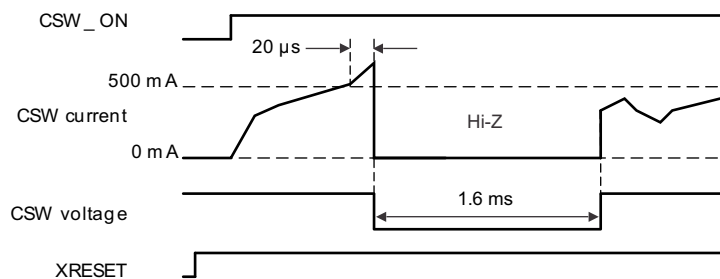

Figure 10. Overcurrent Protection Current Switch

8.3.1.3.4.1 Short Circuit Protection (SCP)

SCP function always monitors the output voltage of high-side and low-side FET of output driver, and when the setting voltage is not outputted, it recognizes as SCP and changed output Hi-Z. It returns to the original state automatically 1.6 ms after.

Table 3. SCP Condition

BLOCK	FUNCTION	DETECTION CONDITION	DETECT TIME	HI-Z HOLD TIME
SPM driver	SCP	Monitor driver output voltage High-side FET output V = GND Low-side FET output V = Supply V	0.8 to 1.6 μ s	1.6 ms
Sled driver				
Load driver				
Actuator driver				

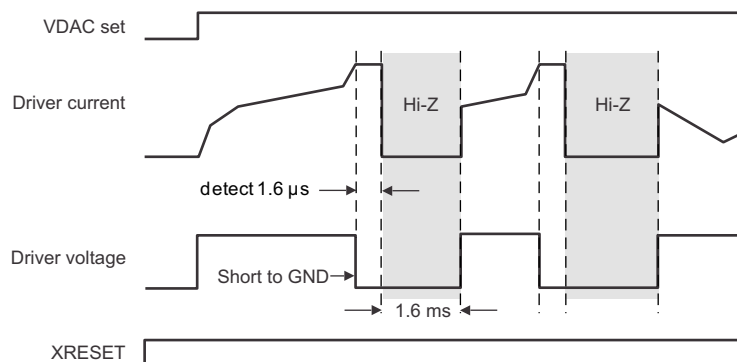

Figure 11. Example of SCP (Driver Short to GND)

8.3.1.4 Thermal Protection (TSD)

The thermal protection (TSD) is a protect function which intercepts an output and suspends an operation when the IC temperature exceed a maximum permissible on a safety. TSD makes an output Hi-Z when the temperature rises up and a threshold value is exceeded. There are two levels for threshold Alert and Trip. Alarm is given by status register TSD_FAULT_ on Alert level with 135°C. It continues rising up temperature, the register TSD_ is set at 150°C and the driver output changes HI-Z. If temperature falls and is reached 135 degrees, it will output again.

TPIC2030 has total 11 temperature sensors in each circuit block. Particular sensor is assigned to appropriate status flag in [Table 4](#).

Table 4. Thermal Sensor Assignment

CIRCUIT	ALERT (°C)	TRIP (°C)	RELEASE (°C)	ALERT FLAG	TRIP FLAG
U	135	150	135	TSD_FAULT_SPM	TSD_SPM
V	135	150	135	TSD_FAULT_SPM	TSD_SPM
W	135	150	135	TSD_FAULT_SPM	TSD_SPM
TLT	135	150	135	TSD_FAULT_ACT	TSD_ACT
FCS	135	150	135	TSD_FAULT_ACT	TSD_ACT
TRK	135	150	135	TSD_FAULT_ACT	TSD_ACT
SLED1	135	150	135	TSD_FAULT_ACT	TSD_ACT
SLED2	135	150	135	TSD_FAULT_ACT	TSD_ACT
LOAD	135	150	135	TSD_FAULT_ACT	TSD_ACT
LED/CSW	135	150	135	TSD_FAULT_LEDCSW	TSD_LEDCSW
DCDC	135	150	135	TSD_FAULT_SWR	TSD_SWR

8.3.1.5 Actuator Temperature Protection (ACTTIMER)

TPIC2030 has an actuator protect function named ACTTIMER. This function protects the IC by setting actuator channel output to HIZ when actuator coil current exceeds the specific value. This circuitry calculates heat accumulation to protect the actuators. When this function operates, sled1, 2 and load channel output will be Hi-Z, too. And spindle channel will be forced Auto short brake and disc motor will stop.

It's able to know the protection has occurred by checking Fault register ACTTIMER_FAULT (REG7F) and ACT_TIMER_PROT (REG78). ACTTIMER_FAULT has a character of advance notice, is set before detecting ACT_TIMER_PROT. Once an ACT_TIMER_PROT is set, even if temperature falls, it will not release protection automatically. It is necessary to clear the flag by setting RST_ERR_FLAG (REG77) or setting 0 to ACTTEMPH (REG72). ACTTIMER function is able to disable by setting H to ACTPROT_OFF (REG72) or setting 0 to ACTTEMPH (REG72).

In order to acquire the optimal value for ACTTEMPH, you should set device into the condition of the detection level, and reading the value of ACTTEMP. Because of the present value can be read from ACTTEMP (REG78).

(1)

(1) The ACTTEMP data is updated on Register in ACTPROT_OFF = 0 and ACTTEMPH > 0.

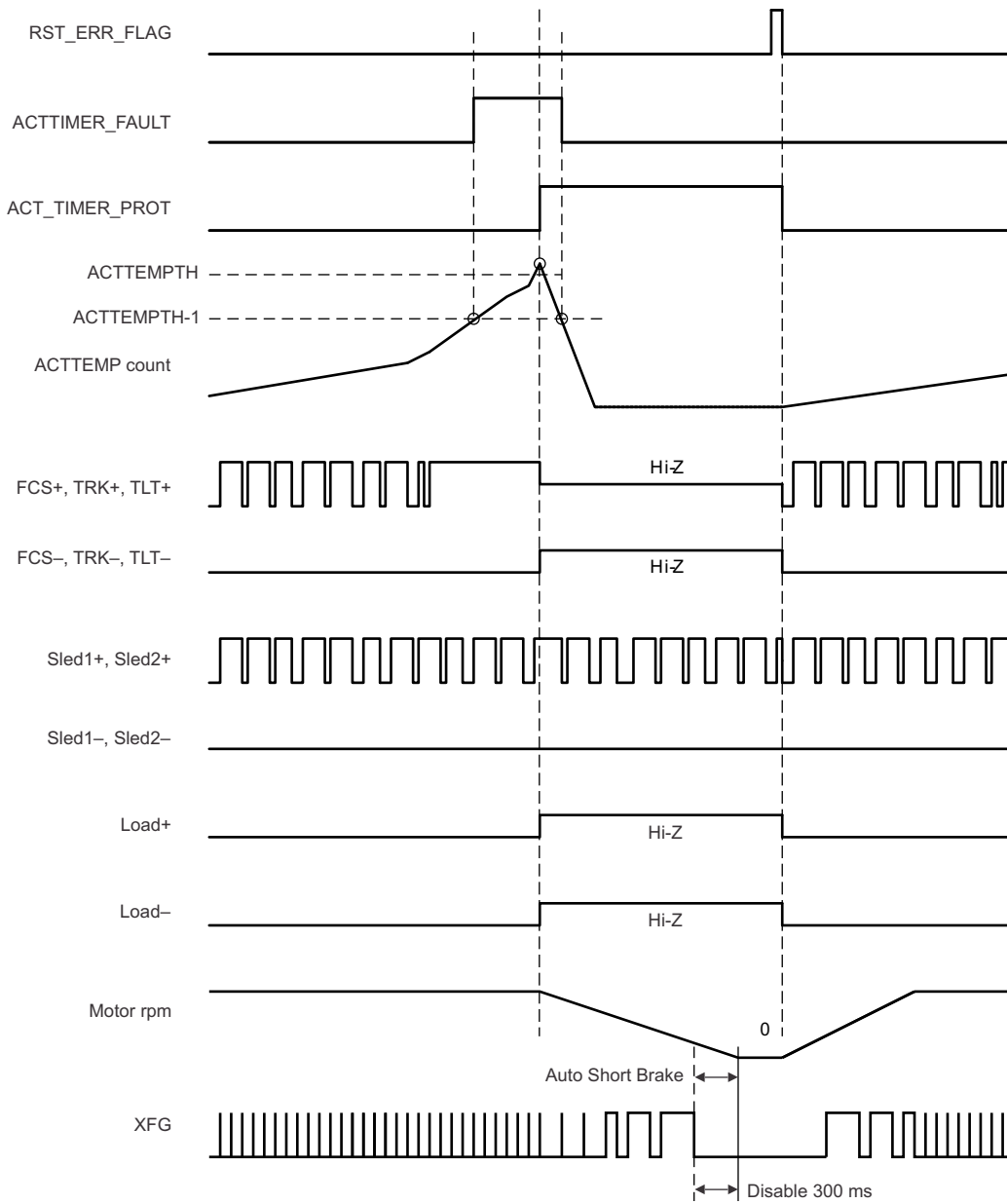

Figure 12. Actuator Temperature Protections

8.4 Device Functional Modes

8.4.1 Power-On Reset (POR)

8.4.1.1 Power-Up Sequences

In TPIC2030, the normal sequence is to wait for 5-V supply to come up to 2.2 V. After 5 V establish, the internal 3.3 V will start and wait until stabilize. Now the voltage monitors start to work and begin to look for the DC-DC converter output. DC-DC converters stabilize the power up sequence finishes and the part starts to function. Once the part finishes all of its power up tasks, it takes XRESET high to indicate that the part is no longer in reset and ready to communicate to the outside world. All the DC-DC converter have soft-start features to avoid rush current and voltage over shoot. Each soft-start sequence takes about 0.8 ms.

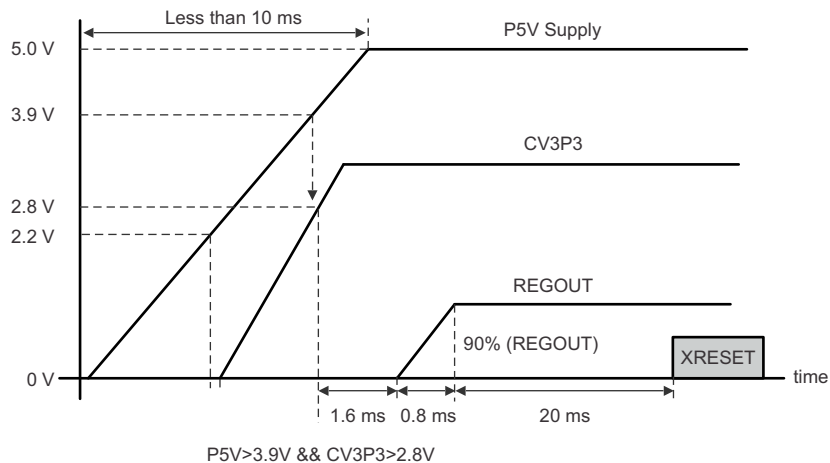

Figure 13. POR (Enable DCDC)

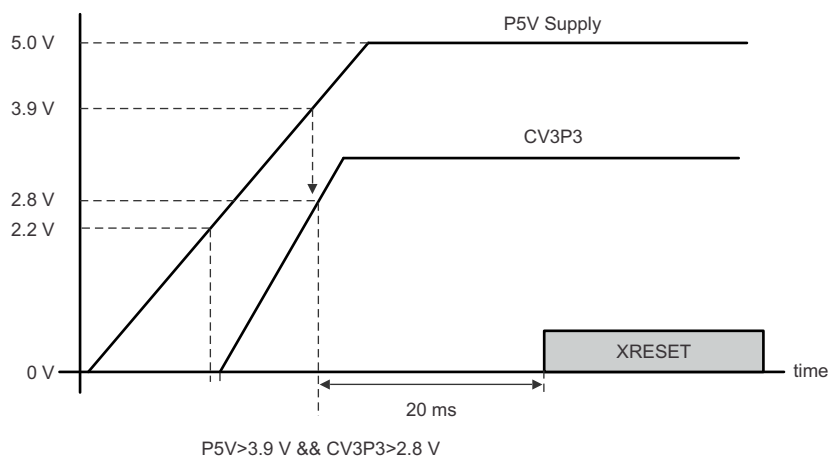

Figure 14. POR (Disable DCDC)

Device Functional Modes (continued)

8.4.1.2 XRESET

TPIC2030 is preparing XRESET pin in order to notify an own status to DSP. TPIC2030 set XRESET to L when the event which has a serious effect on DSP occurs such like the power failure, the over temperature and the drop of DCDC converter output. If all the exception is removed, it will tell that XRESET pin would be set to H and it would be in the ready state. The POR (power-on reset) condition is shown in Figure 15. All the behavior of XRESET is shown in Figure 16.

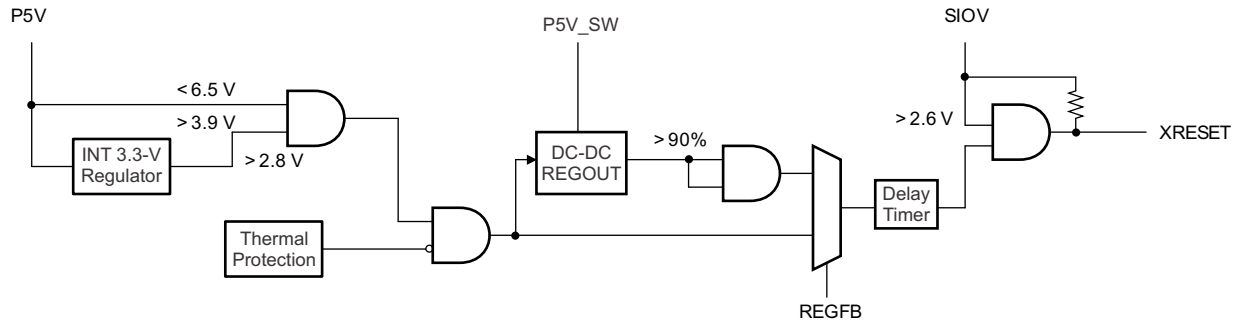
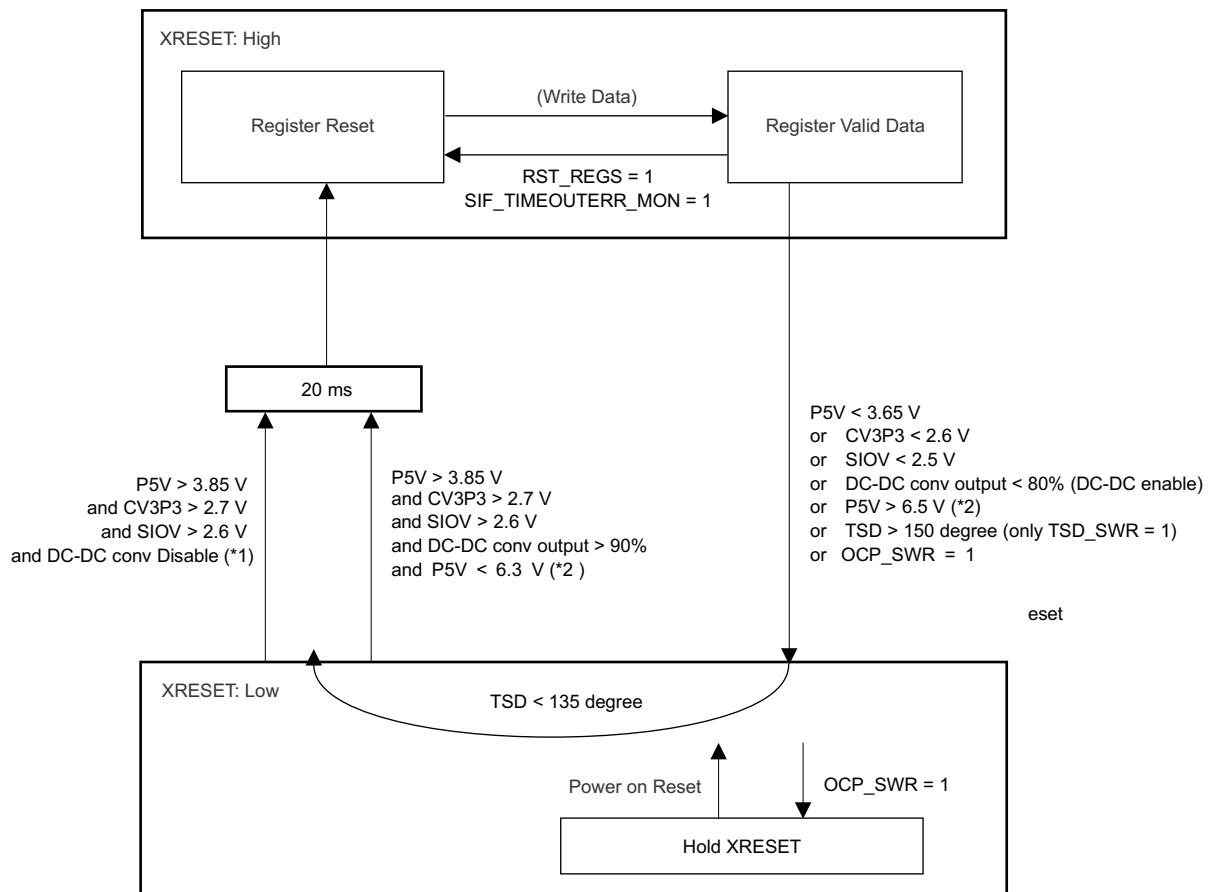

Figure 15. POR Block Diagram



(*1) DC-DC converter disable is REGFB>3.7 V

(*2) When exceed 6.5 V, DC-DC converter output changed Hi-Z and output falling <80%. Consequently force RESET event. (Released > 90%)

Figure 16. XRESET Behavior

Device Functional Modes (continued)

8.4.2 XMUTE

If XMUTE signal is inputted during operation, all the outputs will be suspended and the danger will be avoided.

TPIC2030 will turn off all enable bits, actuator (TLT_ENA/FCS_ENA/TRK_ENA), SPM_ENA, SLD_ENA, LOAD_ENA and CSW_ON when XMUTE input change to L. LOAD_ENA bit will be disabled only when LOAD_05CH = 1. Also log this event to error latch flag XMUTE_DETECT (REG79) and PWRERR (REG7F).

If XMUTE_NORST (REG7F) = 1, change of XMUTE will not influence to enable bits.

8.5 Programming

8.5.1 Serial Port Functional Description

The serial communication of TPIC2030 is based on a SPI communications protocol. TPIC2030 is put on the slave side.

All 16-bit transmission data is effective in SSZ=L period.

The bit stream sent through SIMO from a master (DSP) is latched to an internal shift register by the rising edge of SCLK. All the data is transmitted in a total of 16-bit format of a command and data. A format has two types of data, 8 bits and 12 bits length. In order to access specific registers, an address and R/W flag are specified as a command part. In addition, 12 bit data do not have R/W flag in the packet because DAC register (=12bit data form) are Write only. A transfer packet, command and data, is transmitted sequentially from MSB to LSB. A packet is distinguished in MSB 2 bits of command. In the case of 11, it handles a packet for control register access, and the other processed as a packet for a DAC data setting.

There are the following four kinds of serial-data communication packets.

1. Write 12 bits DAC data (MSB two bit \neq 11)
2. Write 8 bits control register (MSB two bit = 11)
3. Read 8 bits control register (MSB two bit = 11)
4. Write 12 bits Focus DAC data + Read 8 bits status register at the same time (MSB two bit \neq 11)

8.5.2 Write Operation

For write operation, DSP transmits 16 bit (command + address + data) data a bit every in an order from MSB.

Only the 16-bit data which means 16 SCLK sent from the master during SSZ=L becomes effective. If more than 17 or less than 15 SCLK pulses are received during the time that SSZ is low, the whole packet will be ignored. For all valid write operations, the data of the shift register is latched into its designated internal register at rising edge of 16th SCLK. All internal register bits, except indicated otherwise, are reset to their default states upon power-on-reset.

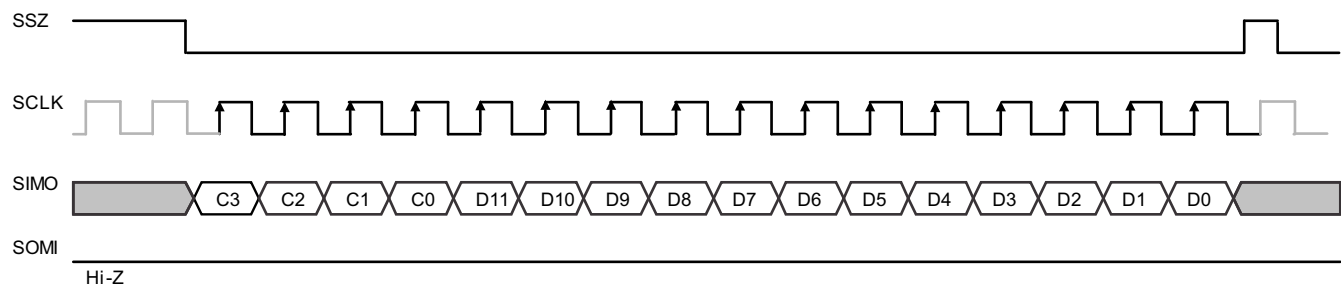

Figure 17. Write 12-Bits DAC Data

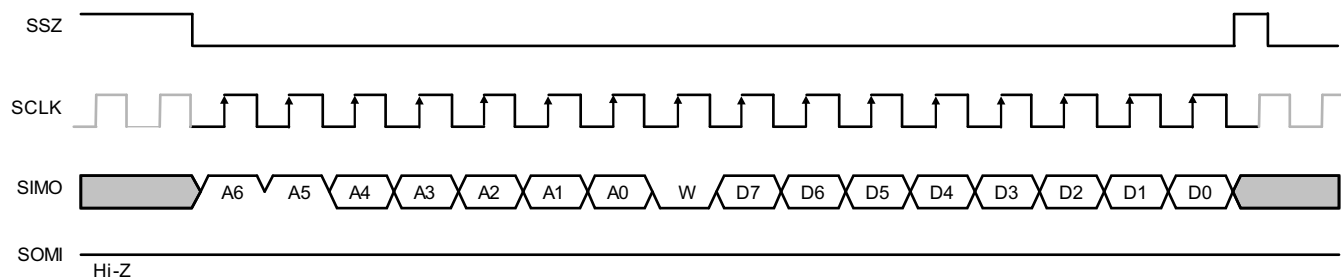

Figure 18. Write 8-Bits Control Register

Programming (continued)

8.5.3 Read Operation

DSP sends 8-bit header through SIMO, in order to perform Read operation. TPIC2030 will start to drive the SOMI line upon the eighth falling edge of SCLK and shift out eight data bits. The master DSP inputs 8-bits data from SOMI after the ninth rising edge of SCLK. There is optional read mode that SOMI data is advanced a half clock cycle of SCLK. This mode becomes effective by setting ADVANCE_RD (REG74) = H.

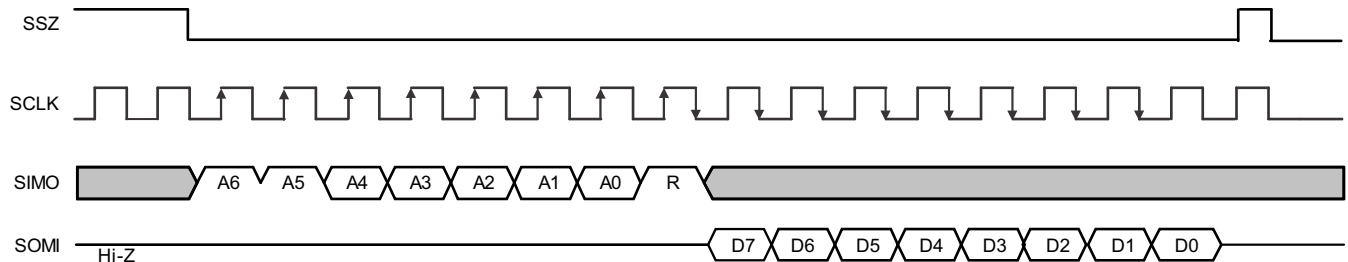

Figure 19. Read 8-Bits Control Register

8.5.4 Write and Read Operation

Optionally, the master DSP can read Status register during writing 12 bits DAC (Focus DAC) packet. It's enabled by setting bit RDSTAT_ON_VFCS (REG74) = H.

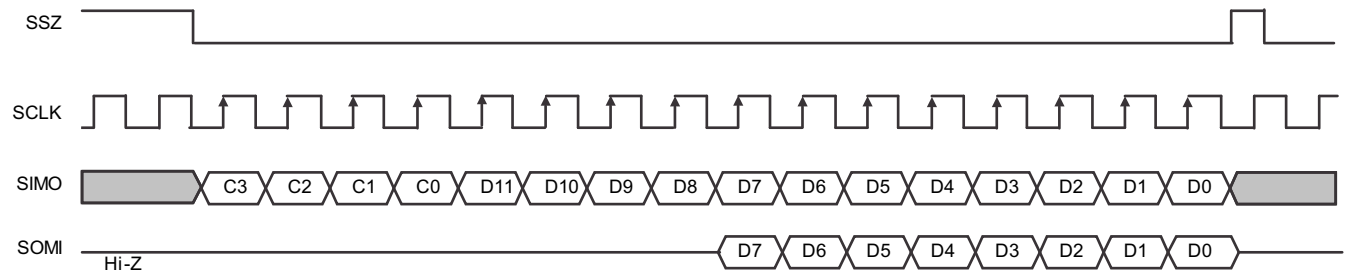

Figure 20. Write 12-Bits Focus DAC Data + Read 8-Bits Status Data

8.6 Register Maps

All registers are in WRITE-protect mode after XRESET release. WRITE_ENA bit (REG76) = H is required before writing data in register.

8.6.1 Register State Transition

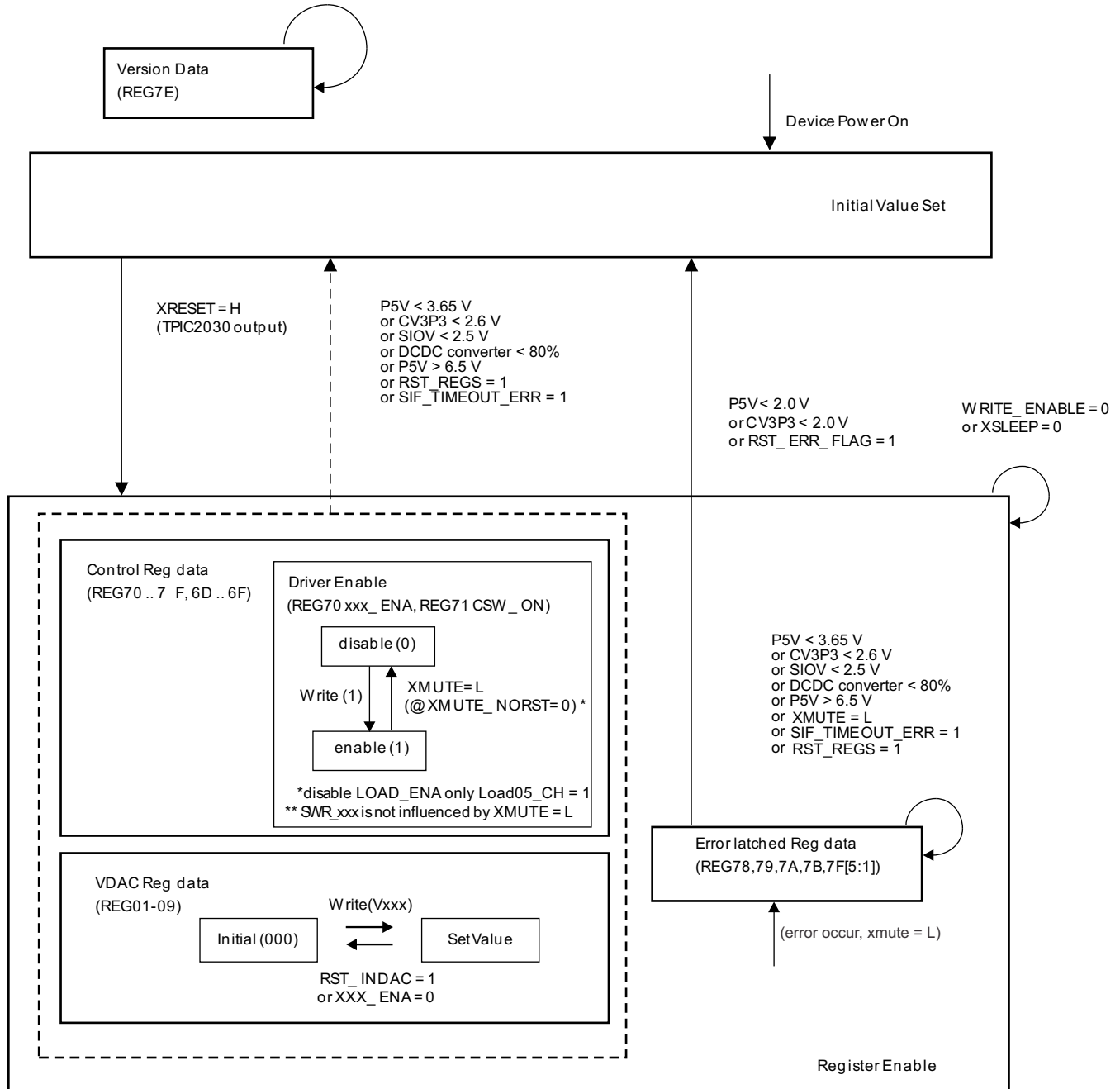

Figure 21. Register State Transition Chart

8.6.2 DAC Register (12-Bit Write Only)

Two difference forms are prepared in 12-bit DAC register, and the forms can be selected by setting VDAC_MAPSW (REG74h).

Table 5. DAC Register (VDAC_MAPSW = 0)

REG	NAME	F	11	10	9	8	7	6	5	4	3	2	1	0
00h	N/A	W	N/A				N/A				N/A			
01h	VTLT	W	VTLT[11]	VTLT[10]	VTLT[9]	VTLT[8]	VTLT[7]	VTLT[6]	VTLT[5]	VTLT[4]	VTLT[3]	VTLT[2]	VTLT[1]	VTLT[0]
02h	VFCS	W	VFCS[11]	VFCS[10]	VFCS[9]	VFCS[8]	VFCS[7]	VFCS[6]	VFCS[5]	VFCS[4]	VFCS[3]	VFCS[2]	VFCS[1]	VFCS[0]
03h	VTRK	W	VTRK[11]	VTRK[10]	VTRK[9]	VTRK[8]	VTRK[7]	VTRK[6]	VTRK[5]	VTRK[4]	VTRK[3]	VTRK[2]	VTRK[1]	VTRK[0]
04h	VSLD1	W	VSLD1[11]	VSLD1[10]	VSLD1[9]	VSLD1[8]	VSLD1[7]	VSLD1[6]	VSLD1[5]	VSLD1[4]	VSLD1[3]	VSLD1[2]	VSLD1[1] ⁽¹⁾	VSLD1[0] ⁽¹⁾
05h	VSLD2	W	VSLD2[11]	VSLD2[10]	VSLD2[9]	VSLD2[8]	VSLD2[7]	VSLD2[6]	VSLD2[5]	VSLD2[4]	VSLD2[3]	VSLD2[2]	VSLD2[1] ⁽¹⁾	VSLD2[0] ⁽¹⁾
06h	N/A	W	N/A				N/A				N/A			
07h	N/A	W	N/A				N/A				N/A			
08h	VSPM	W	VSPM[11]	VSPM[10]	VSPM[9]	VSPM[8]	VSPM[7]	VSPM[6]	VSPM[5]	VSPM[4]	VSPM[3]	VSPM[2]	VSPM[1]	VSPM[0]
09h	VLOAD	W	VLOAD[11]	VLOAD[10]	VLOAD[9]	VLOAD[8]	VLOAD[7]	VLOAD[6]	VLOAD[5]	VLOAD[4]	VLOAD[3]	VLOAD[2]	VLOAD[1]	VLOAD[0]
0Ah	N/A	W	N/A				N/A				N/A			
0Bh	N/A	W	N/A				N/A				N/A			

(1) TPIC2030 process as 0 even if set 1.

Table 6. DAC Register (VDAC_MAPSW = 1)

REG	NAME	F	11	10	9	8	7	6	5	4	3	2	1	0
00h	N/A	W	N/A				N/A				N/A			
01h	VTLT	W	VTRK[11]	VTRK[10]	VTRK[9]	VTRK[8]	VTRK[7]	VTRK[6]	VTRK[5]	VTRK[4]	VTRK[3]	VTRK[2]	VTRK[1]	VTRK[0]
02h	VFCS	W	VFCS[11]	VFCS[10]	VFCS[9]	VFCS[8]	VFCS[7]	VFCS[6]	VFCS[5]	VFCS[4]	VFCS[3]	VFCS[2]	VFCS[1]	VFCS[0]
03h	VTRK	W	VTLT[11]	VTLT[10]	VTLT[9]	VTLT[8]	VTLT[7]	VTLT[6]	VTLT[5]	VTLT[4]	VTLT[3]	VTLT[2]	VTLT[1]	VTLT[0]
04h	VSLD1	W	VSLD1[11]	VSLD1[10]	VSLD1[9]	VSLD1[8]	VSLD1[7]	VSLD1[6]	VSLD1[5]	VSLD1[4]	VSLD1[3]	VSLD1[2]	VSLD1[1] (1)	VSLD1[0] (1)
05h	VSLD2	W	VSLD2[11]	VSLD2[10]	VSLD2[9]	VSLD2[8]	VSLD2[7]	VSLD2[6]	VSLD2[5]	VSLD2[4]	VSLD2[3]	VSLD2[2]	VSLD2[1] (1)	VSLD2[0] (1)
06h	VSPM	W	VSPM[11]	VSPM[10]	VSPM[9]	VSPM[8]	VSPM[7]	VSPM[6]	VSPM[5]	VSPM[4]	VSPM[3]	VSPM[2]	VSPM[1]	VSPM[0]
07h	N/A	W	N/A				N/A				N/A			
08h	N/A	W	N/A				N/A				N/A			
09h	VLOAD	W	N/A				VLOAD[11]	VLOAD[10]	VLOAD[9]	VLOAD[8]	VLOAD[7]	VLOAD[6]	VLOAD[5]	VLOAD[4]
0Ah	N/A	W	N/A				N/A				N/A			
0Bh	N/A	W	N/A				N/A				N/A			

(1) TPIC2030 process as 0 even if set 1.

8.6.3 Control Register

Table 7. Control Register (8bit Read/Write) ⁽¹⁾

REG	NAME	F	7	6	5	4	3	2	1	0	
70h	DriverEna	R/W	TLT_ENA	FCS_ENA	TRK_ENA	SPM_ENA	SLD_ENA	SWR_MD_BURST	LOAD_ENA	XSLEEP	
71h	FuncEna	R/W	SPM_LSMODE	ENDDT_ENA	SWR_BSTAUTON	LED_ON	CSW_ON	TEMPMON_ENA	TI reserved		
72h	ACTCfg	R/W	LOAD_O5CH_HIGH	LOADPROT_OFF	ACTPROT_OFF	ACTTEMPH					
73h	Parm0	R/W	SIF_TIMEOUT_TH		SLEDEND_HZTIME	SLDENDTH		SPM_RCOM_SEL		XMUTE_NORST	
74h	OptSet	R/W	DIFF_TLT	LOAD05_CH	STATUS_ON_VFCS	VSLD2_POL	LOAD_OCP_IUP	TI reserved	SOMI_HIZ	VDAC_MAPSW	
75h	Protect	R/W	TI reserved								
76h	WriteEna	R/W	WRITE_ENABLE	TI reserved							
77h	ClrReg	W	RST_INDAC	RST_REGS	RST_ERR_FLAG	TI reserved					
78h	ActTemp	R	TI reserved		ACT_TIMER_PROT	ACTTEMP					
79h	UVLOMon	R	TI reserved		XMUTE_DETECT	UVLO_P5V	UVLO_INT3P3	UVLO_SIOV	UVLO_SWR	OVP_P5V	
7Ah	TsdMon	R	TSD_FAULT_SWR	TSD_FAULT_SPM	TSD_FAULT_ACT	TSD_FAULT_LEDCSW	TSD_SWR	TSD_SPM	TSD_ACT	TSD_LEDCSW	
7Bh	ProtMon	R	OCP_SWR	OCP_LOAD	OCP_LED	OCP_CSW	SCP_SPM	SCP_SLED	SCP_LOAD	SCP_ACT	
7Ch	TempMon	R	CHIPTMP_STATUS	CHIPTMP							
7Dh	Protect	R	TI reserved								
7Eh	Version	R	Version								
7Fh	Status	R	ACTTIMER_FAULT	ENDDT	SIF_TIMEOUTERR	PWRERR	TSDERR	OCPSCPERR	TSDFAULT	FG	
60h	Protect	R/W	TI reserved								
61h	Protect	R/W	TI reserved								
62h	Protect	R/W	TI reserved								
63h	Protect	R/W	TI reserved								
64h	Protect	R/W	TI reserved								
65h	Protect	R/W	TI reserved						FBSVR_SBRK_OFF	TI reserved	
66h	Protect	R/W	TI reserved								
6Ah	Protect	R/W	TI reserved								
6Ch	Protect	R/W	TI reserved								
6Dh	DCCfg	R/W	TI reserved		SWR_BST_HEFF	TI reserved			SWR_VOUTUP		
6Eh	UtilCfg	R/W	GPOUT_HL	GPOUT_ENA	TI reserved	SWR_GPIO_CNTL	TI reserved				
6Fh	MonitorSet	R/W	ACTTIMER_FLT_MON	ENDDT_MON	SIF_TIMEOUTERR_M ON	PWRERR_MON	TSDERR_MON	OCPSCPERR_MON	TSDFAULT_MON	TI reserved	

(1) VTRK and VLOAD is exclusive, using same DAC block

8.6.4 Detailed Description of Registers

8.6.4.1 REG01 12-bit DAC for Tilt (VDAC_MAPSW = 0)

Figure 22. Tilt (REG01)

15	14	13	12	11	10	9	8
				VTLT			
				w-0	w-0	w-0	w-0
7	6	5	4	3	2	1	0
VTLT							
w-0	w-0	w-0	w-0	w-0	w-0	w-0	w-0

LEGEND: R/W = Read/Write; R = Read only; -n = value after reset

Table 8. Tilt (REG01) Field Descriptions

Bit	Field	Type	Default	Description
11-0	VTLT	w	0	Digital input code for Tilt. 2's compliment format 0x800(-2048) to 0x7ff(+2047) Output is changed by differential Tilt mode (REG74[7]) $TLT_OUT = VTLT * (6.0/2048)$ (DIFF_TLT=0) $TLT_OUT = (VFCS - VTLT) * (6.0/2048)$ (DIFF_TLT=1) TLT_OUT should be changed after writing VFCS. In DIFF_TLT mode (DIFF_TLT=1), TLT_OUT should be changed after writing VFCS.

8.6.4.2 REG02 12-bit DAC for Focus (VDAC_MAPSW = 0)

Figure 23. Focus (REG02)

15	14	13	12	11	10	9	8
				VFCS			
				w-0	w-0	w-0	w-0
7	6	5	4	3	2	1	0
VFCS							
w-0	w-0	w-0	w-0	w-0	w-0	w-0	w-0

LEGEND: R/W = Read/Write; R = Read only; -n = value after reset

Table 9. Focus (REG02) Field Descriptions

Bit	Field	Type	Default	Description
11-0	VFCS	w	0	Digital input code for Focus. 2's compliment format 0x800(-2048) to 0x7ff(+2047) Output is changed by differential Tilt mode (REG74[7]) $FCS_OUT = VFCS * (6.0/2048)$ (DIFF_TLT=0) $FCS_OUT = (VFCS + VTLT) * (6.0/2048)$ (DIFF_TLT=1)

8.6.4.3 REG03 12-bit DAC for Track (VDAC_MAPSW = 0)
Figure 24. Track (REG03)

15	14	13	12	11	10	9	8
				VTRK			
				w-0	w-0	w-0	w-0
7	6	5	4	3	2	1	0
VTRK							
w-0	w-0	w-0	w-0	w-0	w-0	w-0	w-0

LEGEND: R/W = Read/Write; R = Read only; -n = value after reset

Table 10. Track (REG03) Field Descriptions

Bit	Field	Type	Default	Description
11-0	VTRK	w	0	Digital input code for Tracking. 2's compliment format 0x800(-2048) to 0x7ff(+2047) TRK_OUT = VTRK* (6.0/2048)

8.6.4.4 REG04 10bit DAC for Sled1 (VDAC_MAPSW = 0)
Figure 25. Sled1 (REG04)

15	14	13	12	11	10	9	8
				VSLD1			
				w-0	w-0	w-0	w-0
7	6	5	4	3	2	1	0
VSLD1							
w-0	w-0	w-0	w-0	w-0	w-0	w-0	w-0

LEGEND: R/W = Read/Write; R = Read only; -n = value after reset

Table 11. Sled1 (REG04) Field Descriptions

Bit	Field	Type	Default	Description
11-2	VSLD1	w	0	Digital input code for Sled1. 2's compliment format 0x800(-2048) to 0x7ff(+2047) Two bits on LSB, VSLD1[1:0], will be handled with zero. SLD1_OUT = VSLD1* (440mA/2048)
1-0	TI reserved			

8.6.4.5 REG05 10bit DAC for Sled2 (VDAC_MAPSW = 0)
Figure 26. Sled2 (REG05)

15	14	13	12	11	10	9	8
				VSLD2			
		w-0		w-0		w-0	
7	6	5	4	3	2	1	0
				VSLD2			
w-0		w-0		w-0		w-0	

LEGEND: R/W = Read/Write; R = Read only; -n = value after reset

Table 12. Sled2 (REG05) Field Descriptions

Bit	Field	Type	Default	Description
11-2	VSLD2	w	0	Digital input code for Sled2. 2's compliment format 0x800(-2048) to 0x7ff(+2047) Two bits on LSB, VSLD2[1:0], will be handled with zero. SLD2_OUT = VSLD2* (440mA/2048)
1-0	TI reserved			

8.6.4.6 REG08 12-bit DAC for Spindle (VDAC_MAPSW = 0)
Figure 27. Spindle (REG08)

15	14	13	12	11	10	9	8
				VSPM			
		w-0		w-0		w-0	
7	6	5	4	3	2	1	0
				VSPM			
w-0		w-0		w-0		w-0	

LEGEND: R/W = Read/Write; R = Read only; -n = value after reset

Table 13. Spindle (REG08) Field Descriptions

Bit	Field	Type	Default	Description
11-0	VSPM	w	0	Digital input code for Spindle. 2's compliment format 0x800(-2048) to 0x7ff(+2047) SPM_OUT = VSPM* (6.0/2048)

8.6.4.7 REG09 12-bit DAC for Load (VDAC_MAPSW = 0)
Figure 28. Load (REG09)

15	14	13	12	11	10	9	8
				VLOAD			
		w-0		w-0		w-0	
7	6	5	4	3	2	1	0
				VLOAD			
w-0		w-0		w-0		w-0	

LEGEND: R/W = Read/Write; R = Read only; -n = value after reset

Table 14. Load (REG09) Field Descriptions

Bit	Field	Type	Default	Description
11-0	VLOAD	w	0	Digital input code for Load. 2's compliment format 0x800(-2048) to 0x7ff(+2047) LOAD_OUT = VLOAD* (6.0/2048)

8.6.4.8 REG65 8bit Control Register for FBSVR
Figure 29. FBSVR (REG65)

7	6	5	4	3	2	1	0
TI reserved						FBSVR_SBRK _OFF	TI reserved
rw-0	rw-0	rw-0	rw-0	rw-0	rw-0	rw-0	rw-0

LEGEND: R/W = Read/Write; R = Read only; -n = value after reset

Table 15. FBSVR (REG65) Field Descriptions⁽¹⁾

Bit	Field	Type	Default	Description
7-2	TI reserved	rw	0	
1	FBSVR_SBRK_OFF	rw	0	SPM FB saver mode 0: Reset only when F/R transition (Default) 1: Reset all time when SBRK (Recommend)
0	TI reserved	rw	0	

(1) To improve FG behavior, we strongly recommend FBSVR_SBRK_OFF = 1

8.6.4.9 REG6D 8bit Control Register for DCCfg
Figure 30. DCCfg (REG6D)

7	6	5	4	3	2	1	0
TI reserved		SWR_BST_HE FF	TI reserved			SWR_VOUTUP	
rw-0	rw-0	rw-0	rw-0	rw-0	rw-0	rw-0	rw-0

LEGEND: R/W = Read/Write; R = Read only; -n = value after reset

Table 16. DCCfg (REG6D) Field Descriptions

Bit	Field	Type	Default	Description
7-6	TI reserved	rw	0	
5	SWR_BST_HEFF	rw	0	Select high efficiency mode in discontinuous mode (for 1.xV only) 0: normal regulation 1: high efficiency mode
4-2	TI reserved	rw	0	
1-0	SWR_VOUTUP	rw	0	DCDC converter output voltage up. (for 1.xV only) 00: 0%, 01: 2% 10: 3.8% 11: 5.4% (for 1.2V, 1.5V) 00: 0%, 01: 1.3% 10: 2.4% 11: 3.3% (for 1.0V) Prohibit setting in 3.3V output mode.

8.6.4.10 REG6E 8bit Control Register for UtilCfg
Figure 31. UtilCfg (REG6E)

7	6	5	4	3	2	1	0
GPOUT_HL	GPOUT_ENA	TI reserved	SWR_GPIO_C NTL			TI reserved	
rw-0	rw-0	rw-0	rw-0	rw-0	rw-0	rw-0	rw-0

LEGEND: R/W = Read/Write; R = Read only; -n = value after reset

Table 17. UtilCfg (REG6E) Field Descriptions

Bit	Field	Type	Default	Description
7	GPOUT_HL	rw	0	GPOUT (General Purpose Output) pin output selection 0: low output 1: high output valid only REG6F=00h
6	GPOUT_ENA	rw	0	Enable monitor signal output to GPOUT pin 0: No signal output, Hi-Z 1: output signal selected in REG6F with CMOS output Output is Logical OR when selected two more signals
4	SWR_GPIO_CNTL	rw	0	Set GPOUT output value (disable DCDC converter) 0: output L in REGOUT pin (open drain) 1: output H in REGOUT pin (open drain)
3-0	TI reserved	rw	0	

8.6.4.11 REG6F 8bit Control Register for MonitorSet (REG6F)
Figure 32. MonitorSet (REG6F)

7	6	5	4	3	2	1	0
ACTTIMER_FL T_MON	ENDDDET_MON	SIF_TIMEOUT ERR_MON	PWRERR_MO N	TSDERR_MON	OCPPER_M N	TSDFAULT_M ON	TI reserved
rw-0	rw-0	rw-0	rw-0	rw-0	rw-0	rw-0	rw-0

LEGEND: R/W = Read/Write; R = Read only; -n = value after reset

Table 18. MonitorSet (REG6F) Field Descriptions

Bit	Field	Type	Default	Description
7	ACTTIMER_FLT_MON	rw	0	Assign signal to GPIO pin 1: ACTTIMER fault output to GPOUT pin
6	ENDDDET_MON	rw	0	Assign signal to GPIO pin 1: ENDDDET monitor output to GPOUT pin
5	SIF_TIMEOUTERR_MON	rw	0	Assign signal to GPIO pin 1: SIF timeout monitor output to GPOUT pin
4	PWRERR_MON	rw	0	Assign signal to GPIO pin 1: PWRERR monitor output to GPOUT pin
3	TSDERR_MON	rw	0	Assign signal to GPIO pin 1: TSDERR fault output to GPOUT pin
2	OCPPER_MON	rw	0	Assign signal to GPIO pin 1: OCPERR fault output to GPOUT pin
1	TSDFAULT_MON	rw	0	Assign signal to GPIO pin 1: TSDFAULT fault output to GPOUT pin
0	TI reserved	rw	0	

8.6.4.12 REG70 8bit Control Register for DriverEna
Figure 33. DriverEna (REG70)

7	6	5	4	3	2	1	0
TLT_ENA	FCS_ENA	TRK_ENA	SPM_ENA	SLD_ENA	SWR_MD_BURST	LOAD_ENA	XSLEEP
rw-0	rw-0	rw-0	rw-0	rw-0	rw-0	rw-0	rw-0

LEGEND: R/W = Read/Write; R = Read only; -n = value after reset

Table 19. DriverEna (REG70) Field Descriptions

Bit	Field	Type	Default	Description
7	TLT_ENA	rw	0	1 : Tilt enable (with XSLEEP=1) It's reset when XMUTE changes to L.
6	FCS_ENA	rw	0	1: Focus enable (with XSLEEP=1) It's reset when XMUTE changes to L.
5	TRK_ENA	rw	0	1: Track enable (with XSLEEP=1) It's reset when XMUTE changes to L.
4	SPM_ENA	rw	0	1: Spindle enable (with XSLEEP=1) It's reset when XMUTE changes to L.
3	SLD_ENA	rw	0	1: Sled enable (with XSLEEP=1) It's reset when XMUTE changes to L.
2	SWR_MD_BURST	rw	0	1 : Enable DCDC converter discontinuous regulation mode. Regardless of the amount of current consumption, it will always be in discontinuous mode. Holds a former value after XMUTE = L event.
1	LOAD_ENA	rw	0	1 : LOAD enable (with XSLEEP=1) Track (bit5:TRK_ENA) will be disabled at LOAD_ENA=1 because of sharing the DAC PWM module. Load priority is higher than TRK_ENA. It's reset when XMUTE changes to L. (with LOAD_05CH=1)
0	XSLEEP	rw	0	1: Operation mode 0 : Power save mode Charge pump enable bit. All driver enable bit (Bit[7:1]) change disabled and output change to Hi-Z (regardless of setting xxx_ENA bit is 1) when setting XSLEEP to 0. Therefore set 1 to XSLEEP before setting each enable bits.

8.6.4.13 REG71 8bit Control Register for FuncEna

Figure 34. FuncEna (REG71)

7	6	5	4	3	2	1	0
SPM_LSMODE	ENDDT_ENA	SWR_BSTAUT ON	LED_ON	CSW_ON	TEMPMON_EN A	TI reserved	
rw-0	rw-0	rw-0	rw-0	rw-0	rw-0	rw-0	rw-0

LEGEND: R/W = Read/Write; R = Read only; -n = value after reset

Table 20. FuncEna (REG71) Field Descriptions

Bit	Field	Type	Default	Description
7	SPM_LSMODE	rw	0	0 : Spindle rotation mode 1 : Light Scribe mode (slow rotation mode)
6	ENDDT_ENA	rw	0	1 : use Sled end detection enable (with SLD_ENA=1)
5	SWR_BSTAUTON	rw	0	1 : Enable auto DCDC converter discontinuous regulation mode. At low current consumption, it changes to discontinuous mode automatically. Holds a former value after XMUTE = L event. SWR_BSTAUTON mode is chosen when both bit SWR_BSTAUTON and SWR_MD_BURST are set.
4	LED_ON	rw	0	1 : LEDO enable (with XSLEEP=1)
3	CSW_ON	rw	0	1 : CSWO enable (with XSLEEP=1) It's reset when XMUTE changes to L
2	TEMPMON_ENA	rw	0	1: enable chip temperature monitoring (with XSLEEP=1)
1-0	TI reserved	rw	0	

8.6.4.14 REG72 8bit Control Register for ACTCfg

Figure 35. ACTCfg (REG72)

7	6	5	4	3	2	1	0
LOAD_O5CH_ HIGH	LOADPROT_O FF	ACTPROT_OF F			ACTTEMPH		
rw-0	rw-0	rw-0	rw-0	rw-0	rw-0	rw-0	rw-0

LEGEND: R/W = Read/Write; R = Read only; -n = value after reset

Table 21. ACTCfg (REG72) Field Descriptions

Bit	Field	Type	Default	Description
7	LOAD_O5CH_HIGH	rw	0	LOAD output polarity at 0.5CH (REG74h[6]=1) 0: LOADP=Low 1: LOADP=High
6	LOADPROT_OFF	rw	0	1: Load Overcurrent Protection OFF
5	ACTPROT_OFF	rw	0	0 : Actuator protection ON 1 : Actuator Fault monitor disable (No protection for ACT channel)
4-0	ACTTEMPH	rw	0	Actuator thermal protection (=ACT Timer) threshold level ACT Timer Protection enable except ACTTEMPH[4:0]=0x00 ACTTEMPH = 0x00 equal to ACTPROT_OFF = 1 By writing value 0x00, ACTTIMER_PROT flag is cleared.

8.6.4.15 REG73 8bit Control Register for Parm0
Figure 36. Parm0 (REG73)

7	6	5	4	3	2	1	0
SIF_TIMEOUT_TH	SLEDEND_HZ TIME	SLDENDTH	SPM_RCOM_SEL	XMUTE_NORST			
rw-0	rw-0	rw-0	rw-0	rw-0	rw-0	rw-0	rw-0

LEGEND: R/W = Read/Write; R = Read only; -n = value after reset

Table 22. Parm0 (REG73) Field Descriptions

Bit	Field	Type	Default	Description
7-6	SIF_TIMEOUT_TH	rw	0	Watch dog timer for Serial communication 0: disable 1: 1 ms 2: 100 μ s 3: 10 μ s Set SIF_TIMEOUTERR (REG7F) if communication is suspended for this time period. XRESET processing will be performed if a SIF_TIMEOUTERR occurs.
5	SLEDEND_HZTIME	rw	0	Time window for sled end detection. 0: 400 μ s 1: 200 μ s Caution) Need to recycle ENDDT_ENA=0→1 after writing this bit.
4-3	SLDENDTH	rw	0	Sled end detection sensibility setting. Detection threshold for motor BEMF 00: 46 mV; 01: 86 mV; 10: 0 mV; 11: 22 mV
2-1	SPM_RCOM_SEL	rw	0	Select resistor value of spindle current sense resistor. Current limit is set as following current. 00: 890 mA; 01: 980 mA; 10: 725 mA; 11: 784 mA
0	XMUTE_NORST	rw	0	Reset driver enable bit (XXX_ENA and CSW_ON) register at XMUTE = L. 0: Reset enable bit at XMUTE = L 1: XMUTE status does not influence enable bit.

8.6.4.16 REG74 8bit Control Register for OptSet
Figure 37. OptSet (REG74)

7	6	5	4	3	2	1	0
DIFF_TLT	LOAD_05CH	RDSTAT_ON_VFCS	VSLD2_POL	LOAD_OCP_IUP	TI reserved	SOMI_HIZ	VDAC_MAPSW
rw-0	rw-0	rw-0	rw-0	rw-0	rw-0	rw-0	rw-0

LEGEND: R/W = Read/Write; R = Read only; -n = value after reset

Table 23. OptSet (REG74) Field Descriptions

Bit	Field	Type	Default	Description
7	DIFF_TLT	rw	0	1 : Differential Tilt mode enable (with TLT_ENA=FCS_ENA=1) Differential Tilt mode (DIFF_TLT=1), DAC value setting as follows FCS_OUT = (VFCS + VTLT) × 6 / 2048 TLT_OUT = (VFCS – VTLT) × 6 / 2048 In DIFF_TLT mode (DIFF_TLT = 1), TLT_OUT should be changed after writing VFCS.
6	LOAD_05CH	rw	0	The setting of Load motor driving type. Load output changes as follow 0: step down mode (LOAD output is controlled by DAC code, VLOAD) Use for Slot-in model or step down tray model. 1: 0.5Ch mode (LOAD is only controlled by LOAD_05CH_HIGH) Use for Tray model
5	RDSTAT_ON_VFCS	rw	0	Set Read status data (REG7F) at VFCS write command (REG02) 1: enable Write and Read mode (Write 12-bits Focus DAC data + Read 8bits status data)
4	VSLD2_POL	rw	0	change direction of SLED rotation
3	LOAD_OCP_IUP	rw	0	Select over current protection (OCP) threshold for Load channel current 0: 250mA 1: 425mA
2	TI reserved	rw	0	
1	SOMI_HIZ	rw	0	0: SOMI line High-Z at bus idling time. 1: SOMI line Pull Down at bus idling time.
0	VDAC_MAPSW	rw	0	Selection of DAC register channel assignments (REG01–09)

8.6.4.17 REG76 8bit Control Register for WriteEna
Figure 38. WriteEna (REG76)

7	6	5	4	3	2	1	0
WRITE_ENABLE						TI reserved	
rw-0	rw-0	rw-0	rw-0	rw-0	rw-0	rw-0	rw-0

LEGEND: R/W = Read/Write; R = Read only; -n = value after reset

Table 24. WriteEna (REG76) Field Descriptions

Bit	Field	Type	Default	Description
7	WRITE_ENABLE		0	0: Register Write disable except REG76 1: Write enable for registers REG01–0B, REG70–7F, REG6C–6F
6-0	TI reserved			

8.6.4.18 REG77 8bit Control Register for ClrReg
Figure 39. ClrReg (REG77)

7	6	5	4	3	2	1	0
RST_INDAC	RST_REGS	RST_ERR_FLAG	RST_REGS_WO3			TI reserved	
w-0	w-0	w-0	w-0	w-0	w-0	w-0	w-0

LEGEND: R/W = Read/Write; R = Read only; -n = value after reset

Table 25. ClrReg (REG77) Field Descriptions

Bit	Field	Type	Default	Description
7	RST_INDAC	w	0	1 : Reset all 12-bit input DAC register (REG01–0B) *Self clear bit
6	RST_REGS	w	0	1 : Reset all 8bit R/W Registers (REG70h–77h, 60h–6Fh) *Self clear bit
5	RST_ERR_FLAG	w	0	1 : Reset Fault Flag Latch (REG7F[5:1], REG79–REG7B) *Self clear bit
4-0	TI reserved	w	0	

8.6.4.19 REG78 8bit Control Register for ActTemp
Figure 40. ActTemp (REG78)

7	6	5	4	3	2	1	0
TI reserved		ACT_TIMER_PROT			ACTTEMP		
r-0	r-0	r-0	r-0	r-0	r-0	r-0	r-0

LEGEND: R/W = Read/Write; R = Read only; -n = value after reset

Table 26. ActTemp (REG78) Field Descriptions

Bit	Field	Type	Default	Description
7-6	TI reserved	r	0	
5	ACT_TIMER_PROT	r	0	ACT timer protection flag 1: ACT Timer Protection has detected and latched. (ACTTEMP > ACTTEMPH) This bit holds data after temperature change to low since this is a latch bit. Also driver output keep Hi-Z until setting RST_ERR_FLAG or ACTTEMPH=0.
4-0	ACTTEMP	r	0	An integrated value of ACT_TIMER counters at present.

8.6.4.20 REG79 8bit Control Register for UVLOMon
Figure 41. UVLOMon (REG79)

7	6	5	4	3	2	1	0
TI reserved		XMUTE_DETECT	UVLO_P5V	UVLO_INT3P3	UVLO_SIOV	UVLO_SWR	OVP_P5V
r-0	r-0	r-0	r-0	r-0	r-0	r-0	r-0

LEGEND: R/W = Read/Write; R = Read only; -n = value after reset

Table 27. UVLOMon (REG79) Field Descriptions

Bit	Field	Type	Default	Description
7-6	TI reserved	r	0	
5	XMUTE_DETECT	r	0	XMUTE flag for detection Lo input. (>20 μ s) ⁽¹⁾
4	UVLO_P5V	r	0	UVLO (Under Voltage Lock Out) flag for detection Low P5V supply ⁽¹⁾
3	UVLO_INT3P3	r	0	UVLO flag for detection Low internal 3.3-V regulator ⁽¹⁾
2	UVLO_SIOV	r	0	UVLO flag for detection Low SIOV ⁽¹⁾
1	UVLO_SWR	r	0	UVLO flag for detection Low DCDC ⁽¹⁾
0	OVP_P5V	r	0	Over voltage protection flag for P5Vsply ⁽¹⁾

(1) Latched first event only. Cleared by RST_ERR_FLG (REG77)

8.6.4.21 REG7A 8bit Control Register for TsdMon
Figure 42. TsdMon (REG7A)

7	6	5	4	3	2	1	0
TSD_FAULT_S WR	TSD_FAULT_S PM	TSD_FAULT_A CT	TSD_FAULT_L EDCSW	TSD_SWR	TSD_SPM	TSD_ACT	TSD_ LEDCSW
r-0	r-0	r-0	r-0	r-0	r-0	r-0	r-0

LEGEND: R/W = Read/Write; R = Read only; -n = value after reset

Table 28. TsdMon (REG7A) Field Descriptions

Bit	Field	Type	Default	Description
7	TSD_FAULT_SWR	r	0	Pre alert of thermal protection for DCDC converter block ⁽¹⁾
6	TSD_FAULT_SPM	r	0	Pre alert of thermal protection of Spindle block ⁽¹⁾
5	TSD_FAULT_ACT	r	0	Pre alert of thermal protection of Focus /Track /Tilt Sled1 /Sled2 / /Load ⁽¹⁾
4	TSD_FAULT_LEDCSW	r	0	Pre alert of thermal protection of CSW/LED ⁽¹⁾
3	TSD_SWR	r	0	Thermal protection flag for DCDC converter block ⁽¹⁾ DCDC converter output Hi-Z until temperature falls on release level 1: detect (latch)
2	TSD_SPM	r	0	Thermal protection flag for Spindle ⁽¹⁾ SPM output Hi-Z until temperature falls on release level 1: detect (latch)
1	TSD_ACT	r	0	Thermal protection flag for Focus /Track /Tilt Sled1 /Sled2 /Load ⁽¹⁾ Actuator output Hi-Z until temperature falls on release level 1: detect (latch)
0	TSD_LEDCSW	r	0	Thermal protection flag for CSW/LED ⁽¹⁾ LED/CSW output Hi-Z until temperature falls on release level 1: detect (latch)

(1) Cleared by RST_ERR_FLAG bit (REG77)

8.6.4.22 REG7B 8bit Control Register for ProtMon

Figure 43. ProtMon (REG7B)

7	6	5	4	3	2	1	0
OCP_SWR	OCP_LOAD	OCP_LED	OCP_CSW	SCP_SPM	SCP_SLED	SCP_LOAD	SCP_ACT
r-0	r-0	r-0	r-0	r-0	r-0	r-0	r-0

LEGEND: R/W = Read/Write; R = Read only; -n = value after reset

Table 29. ProtMon (REG7B) Field Descriptions

Bit	Field	Type	Default	Description
7	OCP_SWR	r	0	Overcurrent protection flag bit for DCDC converter ⁽¹⁾
6	OCP_LOAD	r	0	Overcurrent protection flag bit for Load channel ⁽¹⁾
5	OCP_LED	r	0	Overcurrent protection flag bit for LED channel ⁽¹⁾
4	OCP_CSW	r	0	Overcurrent protection flag bit for CSW channel ⁽¹⁾
3	SCP_SPM	r	0	Short circuit protection flag bit for spindle channel ⁽¹⁾
2	SCP_SLED	r	0	Short circuit protection flag bit for sled channel ⁽¹⁾
1	SCP_LOAD	r	0	Short circuit protection flag bit for load channel ⁽¹⁾
0	SCP_ACT	r	0	Short circuit protection flag bit for Fcs/Trk/Tilt channel ⁽¹⁾

(1) Cleared by RST_ERR_FLAG bit (REG77)

8.6.4.23 REG7C 8bit Control Register for TempMon

Figure 44. TempMon (REG7C)

7	6	5	4	3	2	1	0
CHIPTEMP_ST ATUS				CHIPTEMP			
r-0	r-0	r-0	r-0	r-0	r-0	r-0	r-0

LEGEND: R/W = Read/Write; R = Read only; -n = value after reset

Table 30. TempMon (REG7C) Field Descriptions

Bit	Field	Type	Default	Description
7	CHIPTEMP_STATUS	r	0	1: New data CHIPTEMP[6:0] is updated It will be cleared after reading.
6-0	CHIPTEMP	r	0	Chip temperature monitor (1.2deg/LSB) 15(0) to 165(127) degrees. For monitoring, TEMPMON_ENA=1 and XSLEEP=1 is required

8.6.4.24 REG7E 8bit Control Register for Version

Figure 45. Version (REG7E)

7	6	5	4	3	2	1	0
Version							
r-0	r-0	r-0	r-0	r-0	r-0	r-0	r-0

LEGEND: R/W = Read/Write; R = Read only; -n = value after reset

Table 31. Version (REG7E) Field Descriptions

Bit	Field	Type	Default	Description
7-0	Version	r	X	Version[7:4] = revision number of TPIC2030 Version[3:0] = option

8.6.4.25 REG7F 8bit Control Register for Status
Figure 46. Status (REG7F)

7	6	5	4	3	2	1	0
ACTTIMER_FAULT	ENDDDET	SIF_TIMEOUT_ERR	PWRERR	TSDERR	OCPEERR	TSDFAULT	FG
r-0	r-0	r-0	r-0	r-0	r-0	r-0	r-0

LEGEND: R/W = Read/Write; R = Read only; -n = value after reset

Table 32. Status (REG7F) Field Descriptions

Bit	Field	Type	Default	Description
7	ACTTIMER_FAULT	r	0	Status flag of ACTTIMER protection 1: Pre alert of ACTTIMER protection. It is close to the threshold level. You can get current ACTTIMER value in REG78. Both of this bit and ACT_TIMER_PROT (REG78) will be set when over the threshold.
6	ENDDDET	r	0	status flag of END detection 1: end position detected (not latch bit)
5	SIF_TIMEOUTERR	r	0	error flag of serial I/F watch dog timer 1: SIF communication was interrupted, expired watch dog timer
4	PWRERR	r	0	error flag of Power 1 : Voltage problem occurred, details in REG79
3	TSDERR	r	0	error flag of any over thermal protections 1: Dispatched thermal protection, details in REG7A
2	OCPEERR	r	0	error flag of any over current protection 1: Dispatched OCP, details in REG7Bh
1	TSDFAULT	r	0	warning of TSD of any thermal protection 1 : Detect pre thermal protection details in REG7A
0	FG	r	0	FG signal. Spindle rotation pulse for speed monitor

9 Application and Implementation

NOTE

Information in the following applications sections is not part of the TI component specification, and TI does not warrant its accuracy or completeness. TI's customers are responsible for determining suitability of components for their purposes. Customers should validate and test their design implementation to confirm system functionality.

NOTE

- Operate every driver channel after 5-V power supplied and stable.
- Appropriate capacity of de-coupling capacitor is required enough value of over 10 μ F due to reduce influence of PWM switching noise. And the P5V pin needs to connect a filter of 1 μ F. It is effective to put bypass capacitor(about 0.1 μ F) near Power pin (P5V_1,P5V_2, P5V_SW,P5V_SPM) for PWM switching noise reduction on power and GND line.
- Much current flow to driver circuits, to consider as below matters.
 - Pattern-lay-out and line-impedance. And noise influence from supply line.

9.1 Application Information

9.1.1 DAC Type

TPIC2030 has nine channels of Actuator. Each channel is assigned to the most suitable DAC engine with a different type respectively. ACT(F/T/Ti) has 12-bit DAC. Upper 8 (MSB sign bit) are converted at a time in 5 MHz and LSB 4 bits are output in sequence with 1.25-MHz PWM. SPIN, SLED, and Load DAC has same DAC types and sampling rate with 312 kHz. All channels except SLED have x6 gain. [Table 33](#) shows configuration of each actuator.

Table 33. DAC Type

	FCS/TRK/TLT	SLED	SPIN	LOAD
Resolution	12 bit	10 bit	12 bit	12 bit
Type	8-bit oversampling	10-bit voltage	8-bit oversampling	8-bit oversampling
Sampling	1.25M / 10bit 312K / 12bit		312K	312K
PWM frequency	312 kHz	About 156 kHz(variable)	156 kHz	312 kHz
Out range	± 6 V	± 440 mA	± 6 V	± 6 V
Feedback	Voltage feedback	Current feedback	Power supply compensation	Voltage feedback Shared with TRK

9.1.2 Example Sampling Rate of 12-Bit DAC for FCS/TRK/TLT

The input data is separated in the upper 8 bits and the lower 4 bits. Upper 8 bits (MSB sign 1 bit) will be put into 8bit current DAC in every 5 MHz. The lower 4bits will be put into one bit current DAC in sequence from upper to lower bit. This one-bit DAC output with PWM in 1.25 MHz. At any PWM duty, 100%, 75%, 50%, 25%, or 0%, will be summed in 8-bit current DAC in every 1.25 MHz. Thus, it takes 3.2 μ s for all lower 4bits summing to PWM output. As a result, 12 bit data is sampled in every PWM cycle. Example of sampling rate for FCS/TRK/TLT is [Figure 47](#).

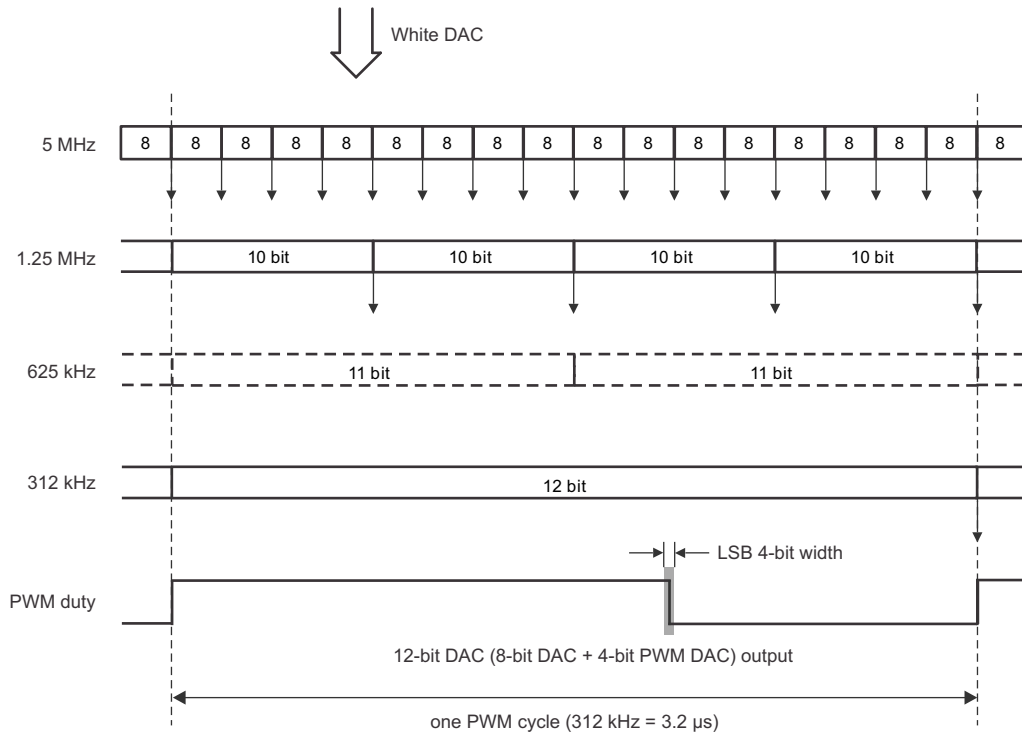

Figure 47. Example of 12-Bit DAC Conversion Time (FCS/TRK/TLT)

9.1.3 Digital Input Coding

The output voltage (current) is commanded via programming to the DAC. All of the DAC input format is 12bit in 2's complement though some DAC has a low resolution. When 12 bits data is input 8 bits DAC, TPIC2030 recognizes four subordinate position bits (LSB) as 0. To arrange for 12-bit DAC format, DSP should shift 8bit or 10 bit data to an appropriate bit position. The full scale is ±1.0 V and driver gain is set 6. The output voltage (Vout) is given by the following equation:

$$V_{out} = DACcode \times \frac{6.0}{2048} \tag{1}$$

$$V_{dac} = 1.0 \times (bit[10] \times 0.5^1 + bit[9] \times 0.5^2 + bit[8] \times 0.5^3 + \dots + bit[0] \times 0.5^{11})$$

$$V_{dac} = (-1.0) \times (bit[10] \times 0.5^1 + bit[9] \times 0.5^2 + bit[8] \times 0.5^3 + \dots + bit[0] \times 0.5^{11} + 0.5^{12})$$

$$V_{out} = V_{dac} \times 6.0 \text{ (V)}$$

$$SLEDI_{out} = V_{dac} \times 0.44 \text{ (A)}$$

where

- bit[11:0] is the digital input value, range 000000000000b to 111111111111b. (2)

Table 34. DAC Format

MSB DIGITAL INPUT (BIN) LSB	HEX	DEC	VDAC	ANALOG OUTPUT
1000_0000_0000	0x800	-2048	-0.9995	-5.997
1000_0000_0001	0x801	-2047	-0.9995	-5.997
1111_1111_1111	0xFFF	-1	-0.0005	-0.003
0000_0000_0000	0x000	0	0	0.000
0000_0000_0001	0x001	+1	+0.0005	+0.003
0111_1111_1110	0x7FE	+2046	+0.9990	+5.994
0111_1111_1111	0x7FF	+2047	+0.9995	+5.997

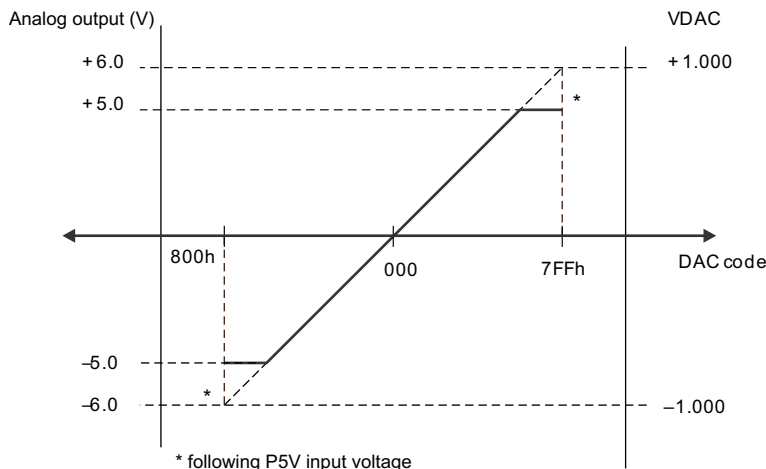

Figure 48. Output Voltage vs DAC Code

9.1.4 Example Timing of Target Control System

TPIC2030 is designed for that meets the requirements updating control data in 400 kHz. The example of control system parameter is listed in . It takes 0.51 μ s for transmit a 16-bit data packet to TPIC2030 with 35 MHz SCLK. Therefore, DSP can be sent four packets a 400-kHz interval. If SCLK is lower than 28.8 MHz, it is required reducing packet quantity under three. For example, Focus/Track command is updating in every 2.5 μ s (400 kHz), and it is able to send another two kind of packet in this same slot. shows the example of the control timing when TPIC2030 is used.

Table 35. Example Timing of Target Control System

SIGNAL	BIT	UPDATE CYCLE (kHz)
Focus	12	400
Track	12	400
Tilt	12	200
Sled1	10	100
Sled2	10	100
Spindle	12	100
Load	12	—

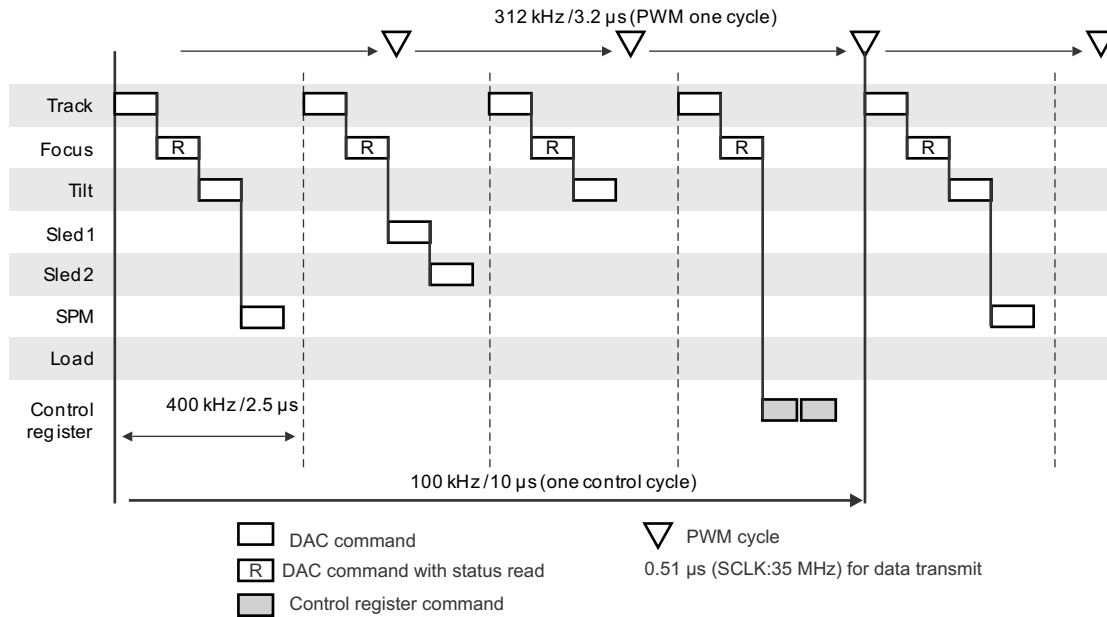

Figure 49. Example DAC Control

9.1.5 Spindle Motor Driver Part

When VSPM is set to a positive DAC code then the part will be in acceleration mode. IS mode operates then the start-up circuit offers the special start-up pattern sequence to the driver in start-up, and then switches to spin-up mode by detecting the rotor position by BEMF signal from the spindle motor coil.

The spin-down and brake function also be controlled by VSPM DAC value. When it is set the brake command to VSPM, driver goes into active-brake mode, then switch to short-brake mode in slow revolution speed, and then stop automatically. The FG signal is composed from EXOR of three-phase signal, and is output from XFG pin shown in Figure 50.

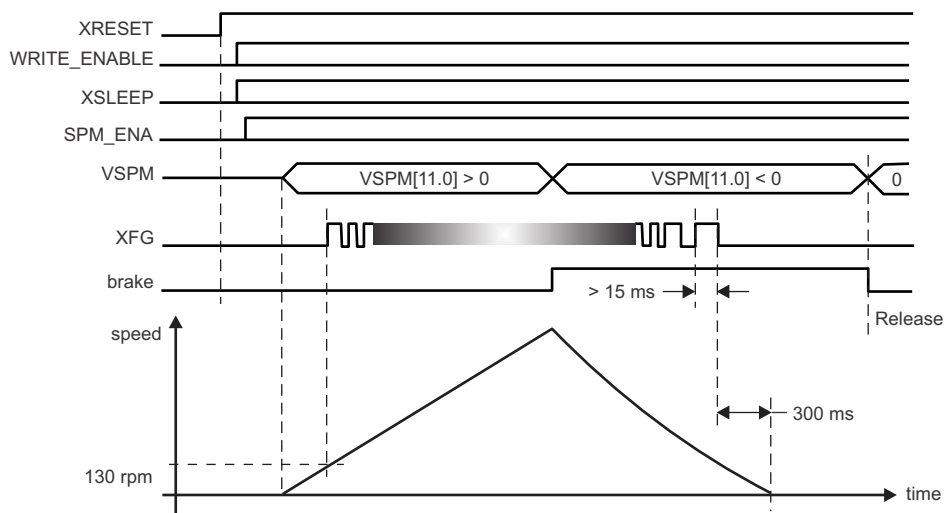

Figure 50. Spindle Operating Sequence

- It is recommended to use down-edge of FG signal for monitoring FG frequency. The FG terminal needs to be pull up to the appropriate supply voltage by external resistor.
- Short Brake mode is asserted after 300 ms of FG signal stays L-level in deceleration.
- The FG output is set to H-level in sleep mode in order to reduce sleep mode current.
- This value is the nominal number of using motor with 16-poles.

- First of all, power supply voltage of P5V must be supplied before any signals input.

9.1.5.1 Spindle PWM Control

The output PWM duty of Spindle is controlled by DAC code (VSPM). The gain in acceleration setting is always six times. However, the maximum output is restricted to P5V_SPM voltage. A dead band which output = 0 exists in the width of plus or minus 0x52 focusing on zero.

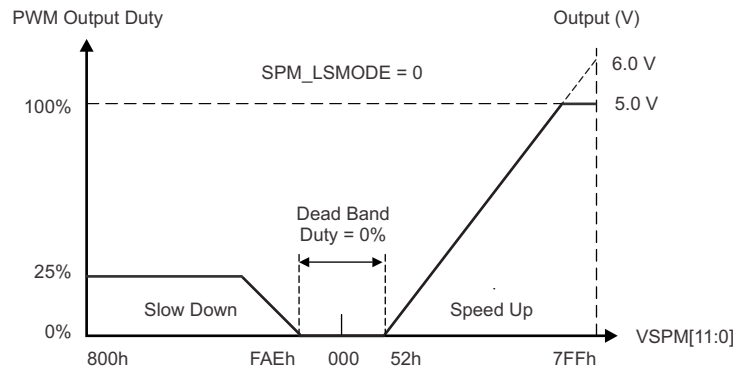

Figure 51. Spindle PWM Control

9.1.5.2 Auto Short Brake Function

TPIC2030 provides auto short brake function which is selecting brake mode automatically by motor speed.

Auto Short Brake is the intelligent brake function that includes 2 modes, Short Brake and Active Brake.

When VSPM value is controlled more than equivalent 75% duty brake, deceleration is done by short brake under the rotation speed is over 3000 rpm. After deceleration, driver goes into Active-brake mode automatically by internal logic circuit under rotation speed is lower 2000 rpm. This function enables low power consumption and silent during braking.

Table 36. Brake Mode

VSPM[11:0]	ROTATION SPEED (RPM)	
	ABOUT 0 TO 2000	ABOUT 3000
0x000 - 0xFAE	2-phase short Brake	2-phase short Brake
0xFAE - 0xA00	Active Brake	Active Brake
0xA00 - 0x800	Active Brake	3-phase short Brake

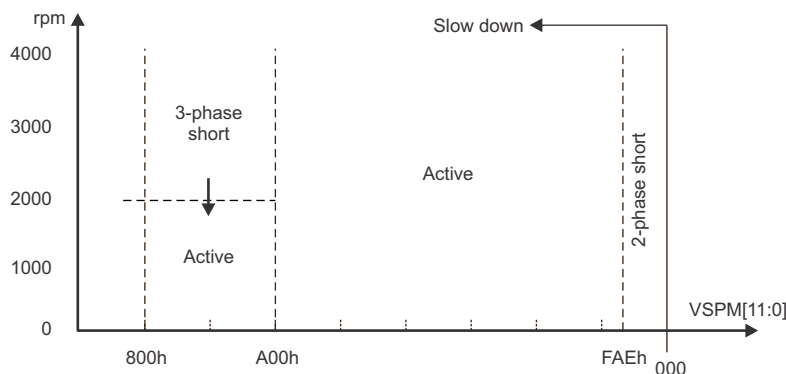

Figure 52. Brake Mode Selections

This value is the nominal number of using motor with 16-poles motor.

9.1.5.3 Spindle Low Speed Mode

LS mode is the low rotation mode which made the maximum 25% duty. When using SPM_LSMODE = 1, brake mode is always SHORT BRAKE. shows the output duty of LS mode.

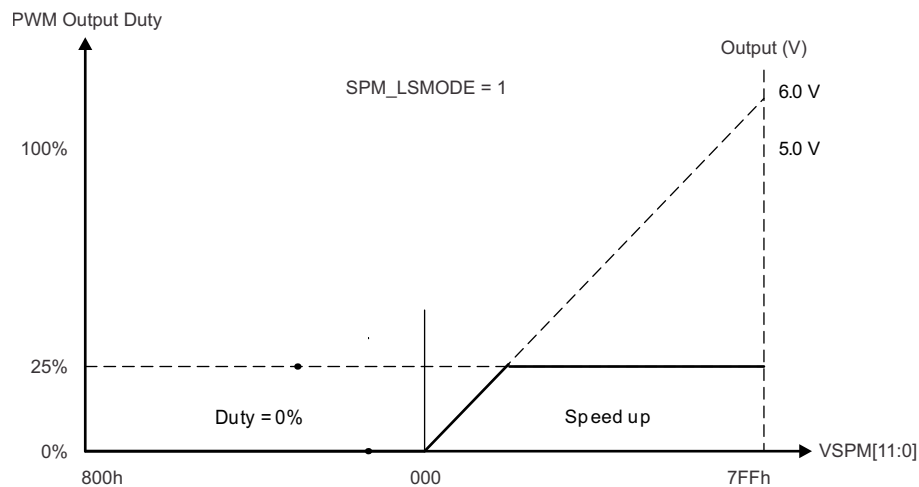

Figure 53. Spindle PWM Control (Low Speed Mode)

9.1.5.4 Spindle Driver Current Limit Circuit

This IC builds in the SPM current sense resistor which can select resistor value. .

The spindle current limit circuit monitors motor current which flows through this resistance, and limits the output current by reducing PWM duty when detecting over current conditions. shows resistor value.

A limit current value can be calculated from following formulas.

Limit current = 196mV / resistor value

Table 37. SPM Current Sense Resistor

SPM_RCOM_SEL[1:0]	RESISTOR VALUE (Ω)	LIMIT CURRENT (mA)
00	0.22	890
01	0.20	980
10	0.27	725
11	0.25	784

9.1.6 Sled Driver Part

9.1.6.1 Sled Channel Input vs Output PWM Duty

The Sled driver outputs the PWM pulse set as DAC code (VSLDx) with current feed back. The maximum output is restricted to 440mA at 0x7FF and 0x800. A dead band which output = 0 exists in the width of plus or minus focusing on zero.

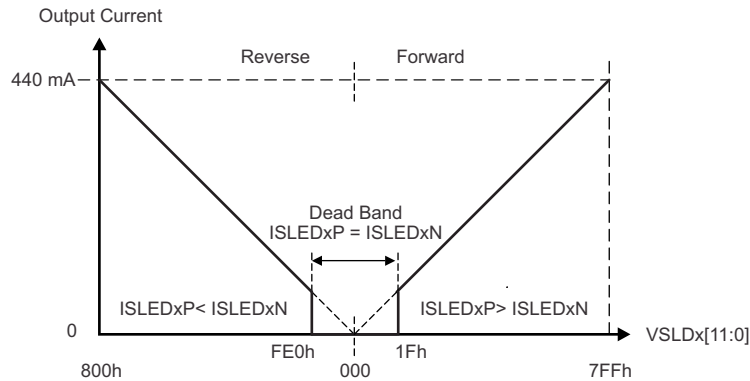

Figure 54. Sled Output Current

- Both outputs of SLED1/2 are L when input code is in dead band.

9.1.6.2 Sled End Detect Function

This device has the function of end position detection for Sled. By this function aim to eliminate the position switch at PUH inner. When this function is enabled, internal logic will detect the sled out zero-cross point and at that time, internal BEMF detect circuit measures the BEMF level of stepping motor. There're four threshold levels. If BEMF is lower than selected threshold, device recognizes motor at stop and ENDDDET bit to 1. ENDDDET bit will be cleared at the BEMF voltage exceed threshold again.

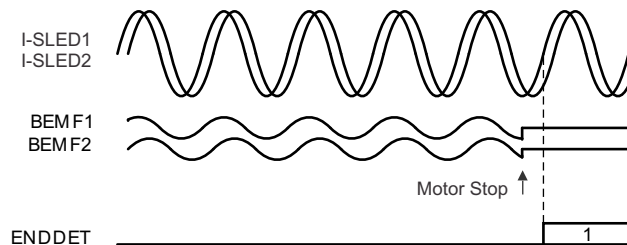

Figure 55. Timing of Sled End Detection

- In order to perform high-precision detection, the sled motor needs to generate higher BEMF voltage. BEMF level depends on the stepping motor characteristic and its speed.
- BEMF detection level is selectable 22, 46, 86 mV.

9.1.7 Load Driver Part

9.1.7.1 Load Channel Input vs Output PWM Duty

Load driver outputs the voltage with voltage feed back corresponding to the input DAC value. This channel has power voltage compensation thus it is suit for Slot-in type load control. This channel becomes active exclusively to other actuator channels. Load driver is shared with the TRK driver.

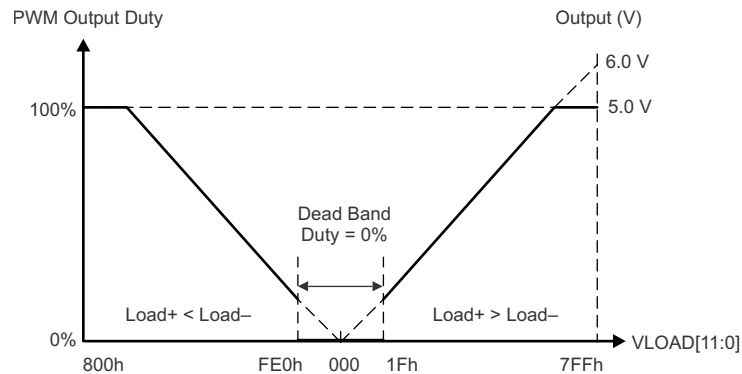
Figure 56. Load Output Duty

- Output voltage is controlled by PWM
- Both LOAD+ and LOAD- are connected to PGND through the internal clamp diode respectively.

9.1.8 Focus/Track/Tilt Driver Part

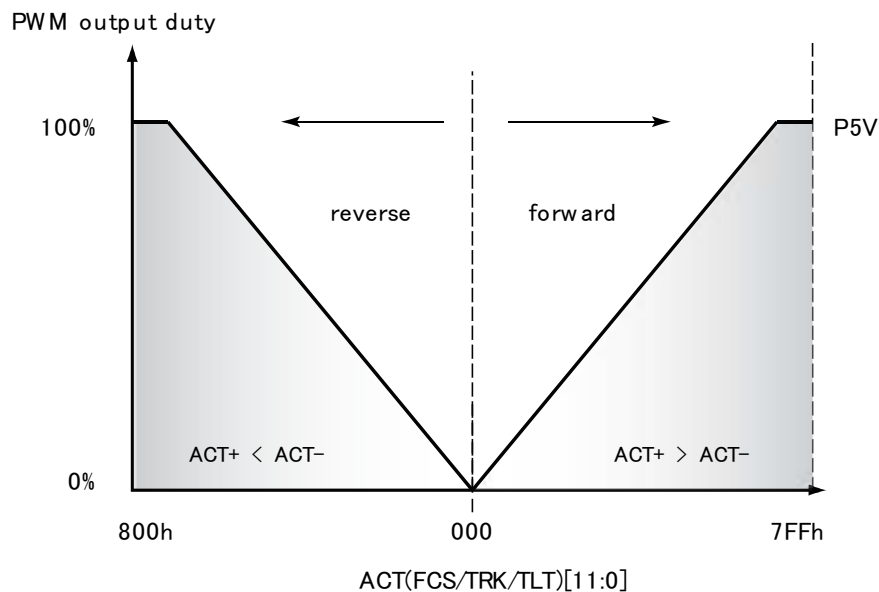
Figure 57. FCS/TRK/TLT Output Duty

9.1.8.1 Differential Tilt Mode

TPIC2030 support differential Tilt mode which output the value calculated from Focus and Tilt. Focus and Tilt can be set in differential mode by DIFF_TLT (REG74) = 1. Because Focus and Tilt are updated at the same time, the update interval of Tilt can be thinned out. Output data changes at after writing VFCS data. Therefore it is necessary to write VFCS data when set VTILT. In differential mode, the output value is calculated as follows.

9.1.9 Step-Down Synchronous DC-DC Converter

TPIC2030 has a synchronous step-down DC-DC converter which can output various voltages. Switching frequency is 2.5MHz. Because the ripple current in the coil can reduce, the smaller inductor value can be selected. And the inductor with lowest DC resistance can be selected for highest efficiency. And the regulators have fast transient response.

Step-down DC-DC converter produces an output 1.0, 1.2, 1.5, and 3.3 V. It only requires an external inductor and bypass capacitor(s). The gate drivers and compensations are all internal to the chip. The required input supply is 5 V for P5V_SW. It has a soft start approximately about 0.8 ms to limit the in-rush current when the regulator comes alive. The soft-start circuit uses the internal clock to profile its ramp.

It's able to up 2%, 3.8% and 5.4% of the output voltage by setting SWR_VOUTUP (REG6D) for 1.2 V and 1.5 V, up 1.3%, 2.4%, and 3.3% for 1.0V.

Table 38. Output Voltage Setting

SWR_VSEL2	SWR_VSEL1	INPUT REGFB	DCDC CONVERTER OUTPUT
0	0	<3.7 V	3.3 V
0	1	<3.7 V	1.2 V
1	0	<3.7 V	1.0 V
1	1	<3.7 V	1.5 V
X	X	over 3.7V	Disable ⁽¹⁾

(1) It is necessary to maintain REGFB > 3.7 V for 100 μs in DC-DC working.

9.1.9.1 Discontinuous Regulation Mode

Provide a regulation mode named discontinuous regulation mode, which improves the conversion efficiency at a low current loading by changing regulation timing. Discontinuous mode is able to set 1 to SWR_MD_BURST (REG6D) bit. Furthermore by setting SWR_BSTAUTON (REG6D), the discontinuous mode is automatically chosen at the time of low power consumption. shows the discontinuous regulation action. The current consumption has been reduced by shortening the energizing time of driving FET. On the other hand, DC voltage ripple grows.

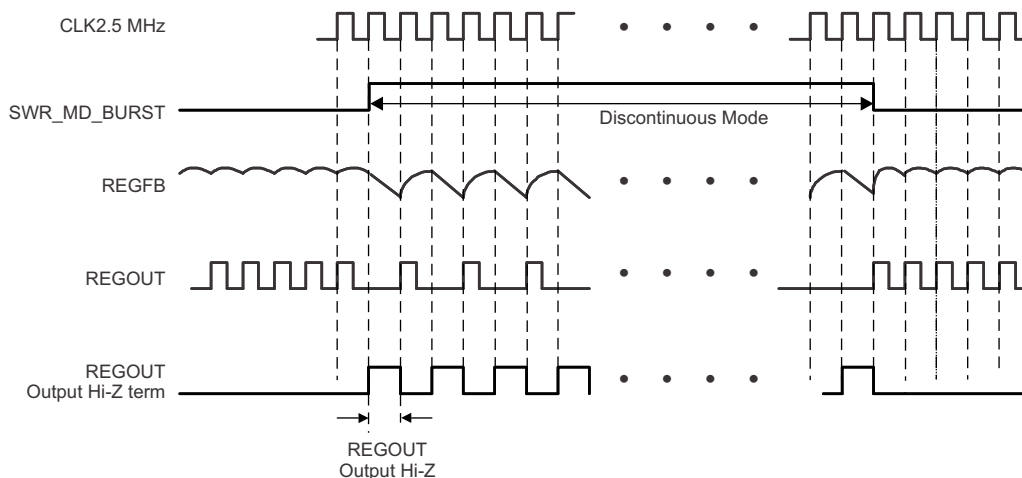

Figure 58. Discontinuous Regulation Mode

9.1.9.2 High Efficiency Mode (in Discontinuous Regulation Mode)

The high efficiency mode which raises efficiency further at the time of low consumption can be chosen for 1.0 V, 1.2 V, and 1.5 V. This mode is selected by SWR_BST_HEFF = 1 (REG6D) in discontinuous mode.

9.1.10 Monitor Signal on GPOUT

The device can output a specific signal to the GPOUT pin. To output a signal, choose a signal from REG6F by enabling first, then enable GPOUT_ENA. When two or more signals are set for GPOUT, the output is a logical sum.

9.2 Typical Application

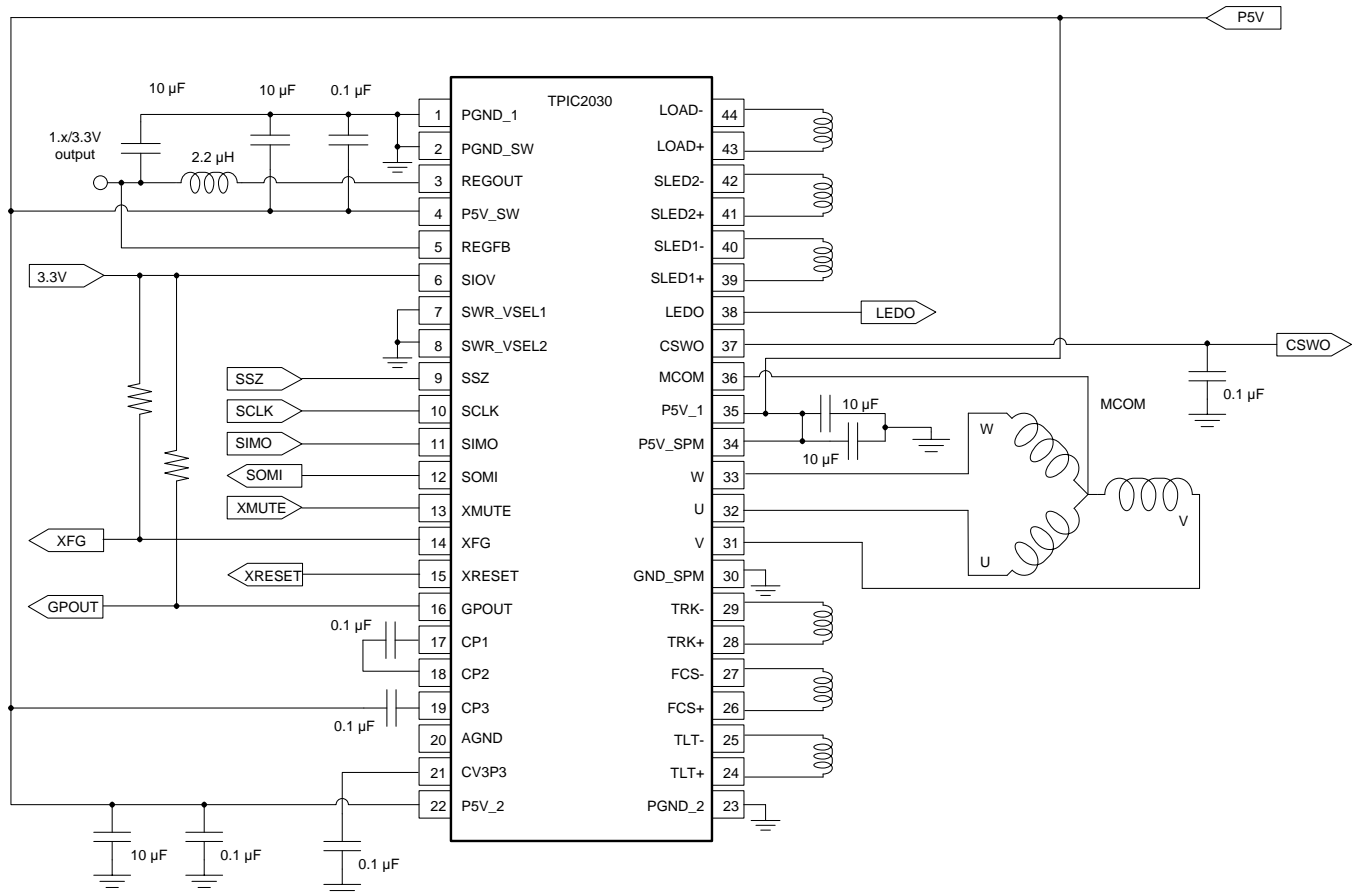

Figure 59. Example of Application Circuit

Table 39. Pin Connection When Specific Function is not Applied

FUNCTION	PIN	NUMBER	CONNECTION
DC-DC converter	SWR_VSEL1	7	GND
	SWR_VSEL2	8	GND
	P5V_SW	4	P5V
	PGND_SW	2	GND
	REGOUT	3	Open
	REGFB	5	P5V

9.2.1 Design Requirements

To begin the design process, determine the following:

1. Motor configuration: The user can use all motor channels or some of them.
2. Power up devices with a 5-V supply.

9.2.2 Detailed Design Procedure

After power up on 5-V supply, the following values may be written to the following registers to enable motors.

1. Set WRITE_ENABLE = 1 on REG76 via SPI.
2. Set XSLEEP = 1 at REG70
3. Enable motor channel by ENA_XXX bits on REG70

4. Change the DAC settings for each motor in REG01-0B. Then, output channels will start driving load.

Table 40. Recommended External Components

PIN	TO	FUNCTION	VALUE (rate)	UNIT
P5V_1	PGND	Noise decoupling	10.0 (10%16 V)	μF
P5V_2	PGND	Noise decoupling	10.0 (10%16 V)	μF
P5V_SW	PGND_SW	Noise decoupling	10.0 (10%16 V)	μF
P5V_SPM	PGND	Noise decoupling	10.0 (10%16 V)	μF
SIOV	PGND	Noise decoupling	1.0 (10%10 V)	μF
REGOUT	REGFB	Inductor (ESR = 0.1 Ω) for DC-DC converter	2.2 (20% 1.2 A)	μH
REGFB	PGND_SW	Capacitor (ESR = 0.025 Ω)	10.0 (10%10 V)	μF
LOAD_P	PGND	Prevent surge current	10000 (10% 16 V)	pF
LOAD_N	PGND	Prevent surge current	10000(10% 16 V)	pF
CP1	CP2	Charge pump capacitor	0.1 (10% 16 V)	μF
CP3	P5V	Charge pump capacitor (P5V only, prohibit other power supply)	0.1 (10% 16 V)	μF

Table 41. Specific for DCDC Converter Components

COMPONENTS	RECOMMENDED VALUE	RECOMMENDED SUPPLIER	PART NUMBER
Inductor	2.2 (μH)	TAIYO YUDEN	BRL2518T2R2M
Capacitor	10 (μF)	MURATA	GRM21BB31A106KE18L

9.2.3 Application Curves

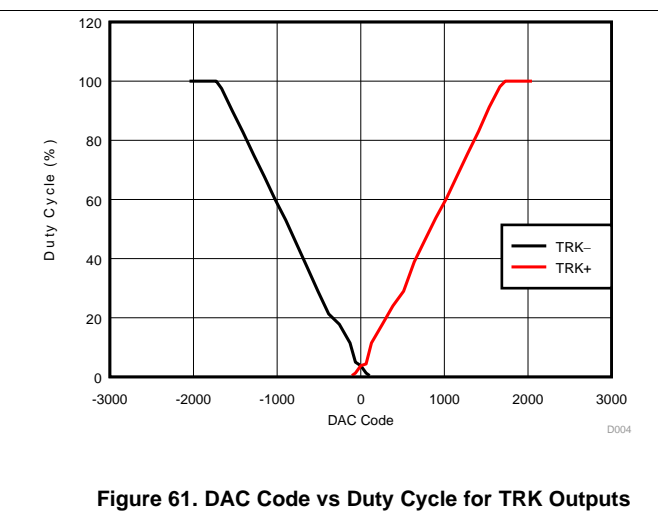
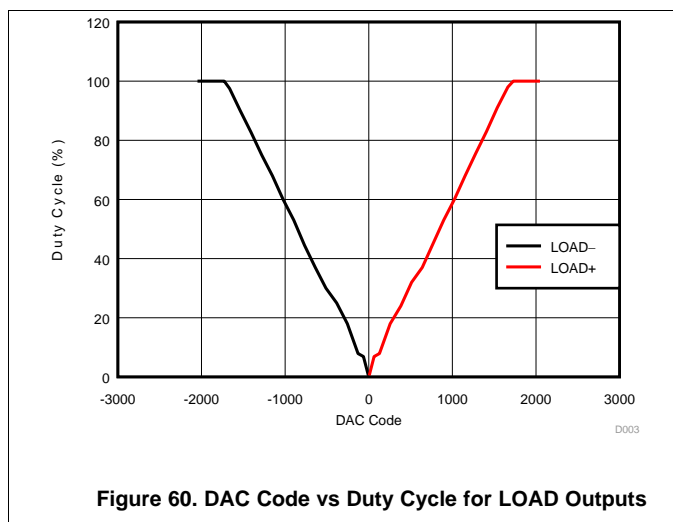

10 Power Supply Recommendations

All driver channels should be operated after the required power is supplied and stable.

The appropriate capacity of the decoupling capacitor requires a value over 10 μF to reduce the influence of PWM switching noise. The P5V1, P5V2, P5V_SW, and P5V_SPM pins must connect to 10- μF decoupling capacitors.

Current flow to the driver circuits takes both pattern-layout, line-impedance, and noise influence from the supply line into consideration.

11 Layout

11.1 Layout Guidelines

1. CV3P3V requires an external capacitor. Because these are reference voltage for device, locate the capacitor as close to device as possible. Keep away from noise sources.
2. TI recommends SCLK ground shielding.
3. Place the inductor for the DC-DC converter as close to the chip as possible, and keep the feedback line to the REGFB pin as short as possible.

11.2 Layout Example

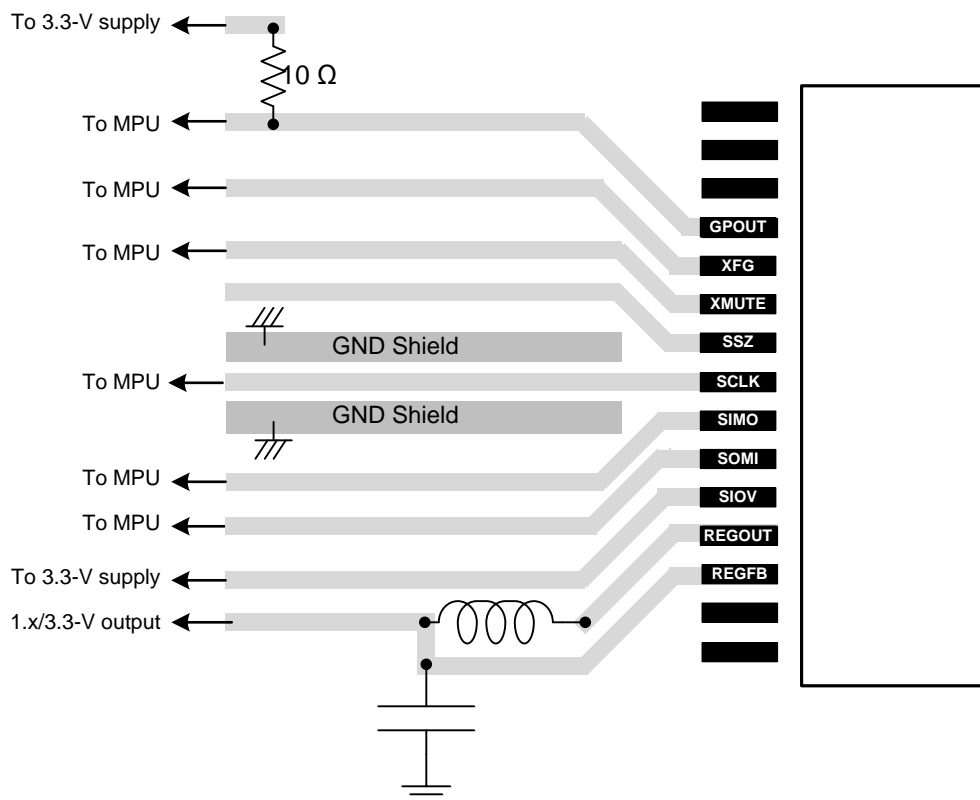

Figure 62. Layout Recommendation

12 Device and Documentation Support

12.1 Device Support

12.1.1 Third-Party Products Disclaimer

TI'S PUBLICATION OF INFORMATION REGARDING THIRD-PARTY PRODUCTS OR SERVICES DOES NOT CONSTITUTE AN ENDORSEMENT REGARDING THE SUITABILITY OF SUCH PRODUCTS OR SERVICES OR A WARRANTY, REPRESENTATION OR ENDORSEMENT OF SUCH PRODUCTS OR SERVICES, EITHER ALONE OR IN COMBINATION WITH ANY TI PRODUCT OR SERVICE.

12.2 Community Resources

The following links connect to TI community resources. Linked contents are provided "AS IS" by the respective contributors. They do not constitute TI specifications and do not necessarily reflect TI's views; see TI's [Terms of Use](#).

TI E2E™ Online Community *TI's Engineer-to-Engineer (E2E) Community*. Created to foster collaboration among engineers. At e2e.ti.com, you can ask questions, share knowledge, explore ideas and help solve problems with fellow engineers.

Design Support *TI's Design Support* Quickly find helpful E2E forums along with design support tools and contact information for technical support.

12.3 Trademarks

E2E is a trademark of Texas Instruments.
All other trademarks are the property of their respective owners.

12.4 Electrostatic Discharge Caution



These devices have limited built-in ESD protection. The leads should be shorted together or the device placed in conductive foam during storage or handling to prevent electrostatic damage to the MOS gates.

12.5 Glossary

[SLYZ022](#) — *TI Glossary*.

This glossary lists and explains terms, acronyms, and definitions.

13 Mechanical, Packaging, and Orderable Information

The following pages include mechanical, packaging, and orderable information. This information is the most current data available for the designated devices. This data is subject to change without notice and revision of this document. For browser-based versions of this data sheet, refer to the left-hand navigation.

PACKAGING INFORMATION

Orderable Device	Status (1)	Package Type	Package Drawing	Pins	Package Qty	Eco Plan (2)	Lead/Ball Finish (6)	MSL Peak Temp (3)	Op Temp (°C)	Device Marking (4/5)	Samples
TPIC2030DBTRG4	ACTIVE	TSSOP	DBT	44	2000	Green (RoHS & no Sb/Br)	CU NIPDAU	Level-2-260C-1 YEAR	-20 to 75	TPIC2030	Samples

(1) The marketing status values are defined as follows:

ACTIVE: Product device recommended for new designs.

LIFEBUY: TI has announced that the device will be discontinued, and a lifetime-buy period is in effect.

NRND: Not recommended for new designs. Device is in production to support existing customers, but TI does not recommend using this part in a new design.

PREVIEW: Device has been announced but is not in production. Samples may or may not be available.

OBSOLETE: TI has discontinued the production of the device.

(2) Eco Plan - The planned eco-friendly classification: Pb-Free (RoHS), Pb-Free (RoHS Exempt), or Green (RoHS & no Sb/Br) - please check <http://www.ti.com/productcontent> for the latest availability information and additional product content details.

TBD: The Pb-Free/Green conversion plan has not been defined.

Pb-Free (RoHS): TI's terms "Lead-Free" or "Pb-Free" mean semiconductor products that are compatible with the current RoHS requirements for all 6 substances, including the requirement that lead not exceed 0.1% by weight in homogeneous materials. Where designed to be soldered at high temperatures, TI Pb-Free products are suitable for use in specified lead-free processes.

Pb-Free (RoHS Exempt): This component has a RoHS exemption for either 1) lead-based flip-chip solder bumps used between the die and package, or 2) lead-based die adhesive used between the die and leadframe. The component is otherwise considered Pb-Free (RoHS compatible) as defined above.

Green (RoHS & no Sb/Br): TI defines "Green" to mean Pb-Free (RoHS compatible), and free of Bromine (Br) and Antimony (Sb) based flame retardants (Br or Sb do not exceed 0.1% by weight in homogeneous material)

(3) MSL, Peak Temp. - The Moisture Sensitivity Level rating according to the JEDEC industry standard classifications, and peak solder temperature.

(4) There may be additional marking, which relates to the logo, the lot trace code information, or the environmental category on the device.

(5) Multiple Device Markings will be inside parentheses. Only one Device Marking contained in parentheses and separated by a "~" will appear on a device. If a line is indented then it is a continuation of the previous line and the two combined represent the entire Device Marking for that device.

(6) Lead/Ball Finish - Orderable Devices may have multiple material finish options. Finish options are separated by a vertical ruled line. Lead/Ball Finish values may wrap to two lines if the finish value exceeds the maximum column width.

Important Information and Disclaimer: The information provided on this page represents TI's knowledge and belief as of the date that it is provided. TI bases its knowledge and belief on information provided by third parties, and makes no representation or warranty as to the accuracy of such information. Efforts are underway to better integrate information from third parties. TI has taken and continues to take reasonable steps to provide representative and accurate information but may not have conducted destructive testing or chemical analysis on incoming materials and chemicals. TI and TI suppliers consider certain information to be proprietary, and thus CAS numbers and other limited information may not be available for release.

In no event shall TI's liability arising out of such information exceed the total purchase price of the TI part(s) at issue in this document sold by TI to Customer on an annual basis.

TAPE AND REEL INFORMATION



QUADRANT ASSIGNMENTS FOR PIN 1 ORIENTATION IN TAPE



*All dimensions are nominal

Device	Package Type	Package Drawing	Pins	SPQ	Reel Diameter (mm)	Reel Width W1 (mm)	A0 (mm)	B0 (mm)	K0 (mm)	P1 (mm)	W (mm)	Pin1 Quadrant
TPIC2030DBTRG4	TSSOP	DBT	44	2000	330.0	24.4	6.8	11.7	1.6	12.0	24.0	Q1

TAPE AND REEL BOX DIMENSIONS



*All dimensions are nominal

Device	Package Type	Package Drawing	Pins	SPQ	Length (mm)	Width (mm)	Height (mm)
TPIC2030DBTRG4	TSSOP	DBT	44	2000	350.0	350.0	43.0

EXAMPLE BOARD LAYOUT

DBT0044A

TSSOP - 1.2 mm max height

SMALL OUTLINE PACKAGE

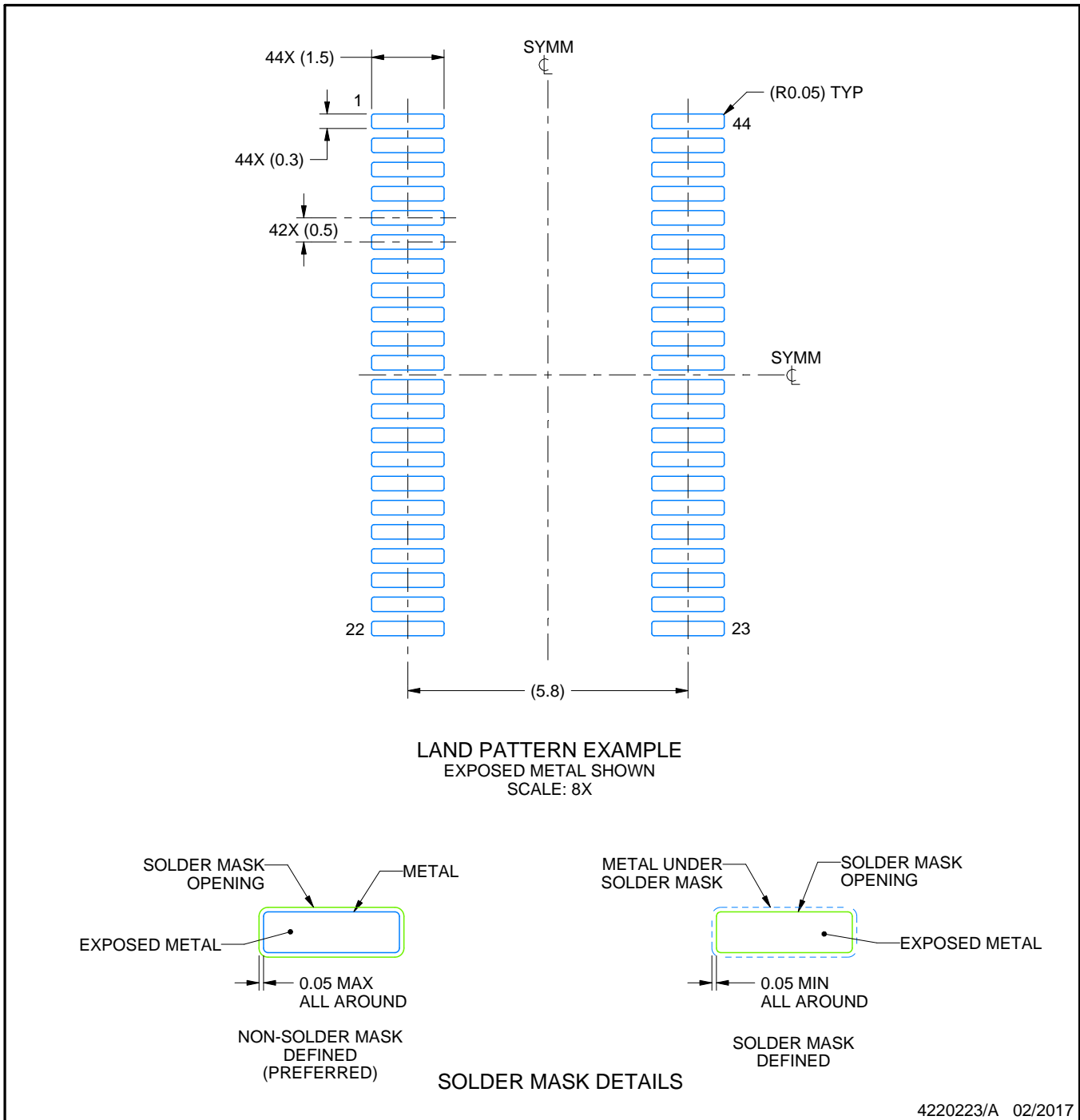

NOTES: (continued)

- Publication IPC-7351 may have alternate designs.
- Solder mask tolerances between and around signal pads can vary based on board fabrication site.

EXAMPLE STENCIL DESIGN

DBT0044A

TSSOP - 1.2 mm max height

SMALL OUTLINE PACKAGE

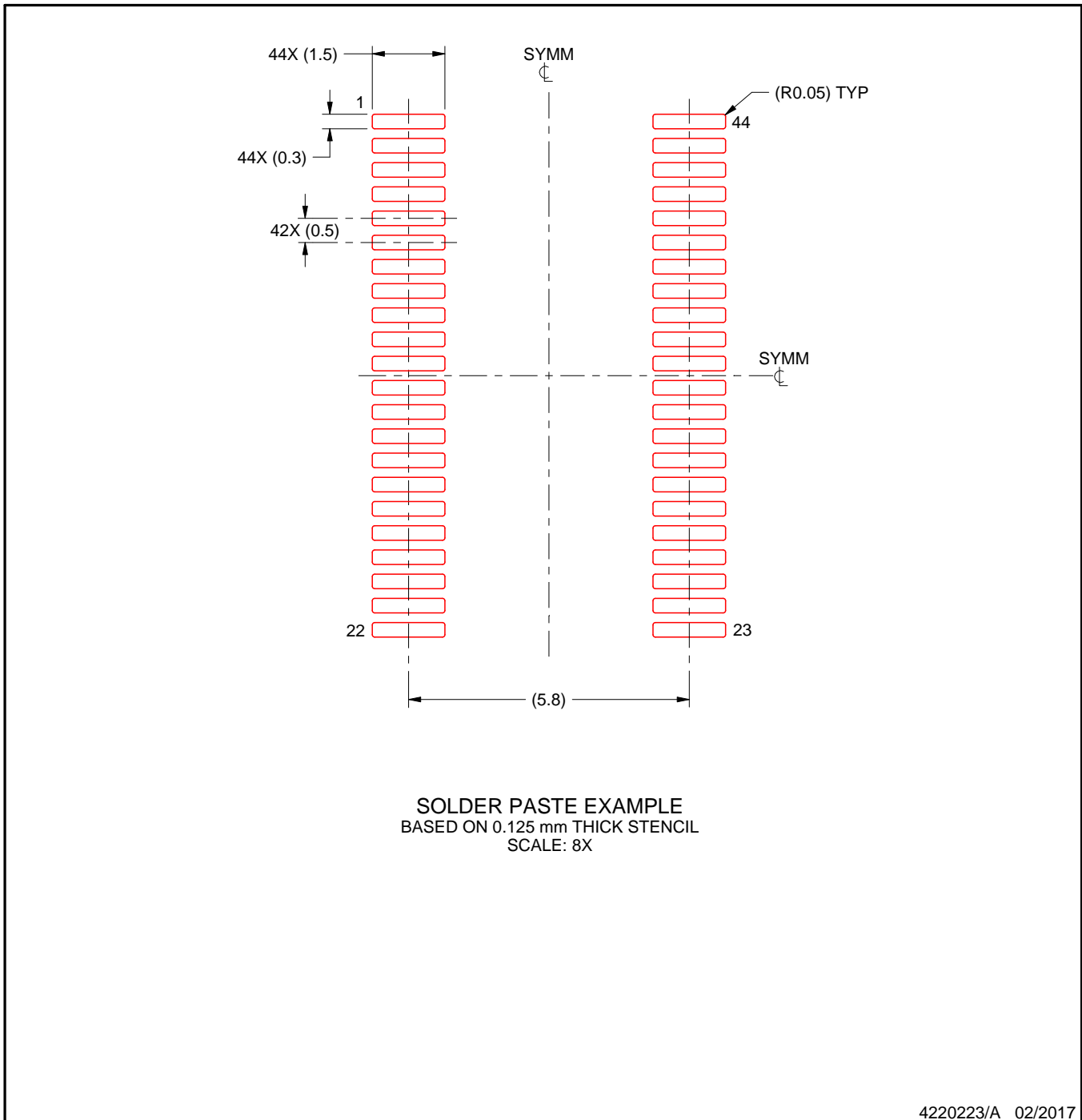

NOTES: (continued)

7. Laser cutting apertures with trapezoidal walls and rounded corners may offer better paste release. IPC-7525 may have alternate design recommendations.
8. Board assembly site may have different recommendations for stencil design.

IMPORTANT NOTICE AND DISCLAIMER

TI PROVIDES TECHNICAL AND RELIABILITY DATA (INCLUDING DATASHEETS), DESIGN RESOURCES (INCLUDING REFERENCE DESIGNS), APPLICATION OR OTHER DESIGN ADVICE, WEB TOOLS, SAFETY INFORMATION, AND OTHER RESOURCES "AS IS" AND WITH ALL FAULTS, AND DISCLAIMS ALL WARRANTIES, EXPRESS AND IMPLIED, INCLUDING WITHOUT LIMITATION ANY IMPLIED WARRANTIES OF MERCHANTABILITY, FITNESS FOR A PARTICULAR PURPOSE OR NON-INFRINGEMENT OF THIRD PARTY INTELLECTUAL PROPERTY RIGHTS.

These resources are intended for skilled developers designing with TI products. You are solely responsible for (1) selecting the appropriate TI products for your application, (2) designing, validating and testing your application, and (3) ensuring your application meets applicable standards, and any other safety, security, or other requirements. These resources are subject to change without notice. TI grants you permission to use these resources only for development of an application that uses the TI products described in the resource. Other reproduction and display of these resources is prohibited. No license is granted to any other TI intellectual property right or to any third party intellectual property right. TI disclaims responsibility for, and you will fully indemnify TI and its representatives against, any claims, damages, costs, losses, and liabilities arising out of your use of these resources.

TI's products are provided subject to TI's Terms of Sale (www.ti.com/legal/termsofsale.html) or other applicable terms available either on ti.com or provided in conjunction with such TI products. TI's provision of these resources does not expand or otherwise alter TI's applicable warranties or warranty disclaimers for TI products.

Mailing Address: Texas Instruments, Post Office Box 655303, Dallas, Texas 75265
Copyright © 2019, Texas Instruments Incorporated

Looking for pricing, stock, or lifecycle information?

Click below to explore more details on WIN SOURCE:

 [View TPIC2030DBTRG4 on WIN SOURCE](#)

 [Texas Instruments](#) Information

Optimize Your Supply Chain with WIN SOURCE Solutions

-  Global Sourcing Solution
-  Obsolete Management
-  Cost Control Management
-  Shortage Management
-  Alternative Solution
-  Excess Inventory Management