



THE DATASHEET OF NBSG53ABAR2



NBSG53A

2.5 V/3.3 V SiGe Selectable Differential Clock and Data D Flip-Flop/Clock Divider with Reset and OLS*

The NBSG53A is a multi-function differential D flip-flop (DFF) or fixed divide by two (DIV/2) clock generator. This is a part of the GigaComm™ family of high performance Silicon Germanium products. A strappable control pin is provided to select between the two functions. The device is housed in a low profile 4x4 mm 16-pin Flip-Chip BGA (FCBGA) or a 3x3 mm 16 pin QFN package.

The NBSG53A is a device with data, clock, OLS*, reset, and select inputs. Differential inputs incorporate internal 50 Ω termination resistors and accept NECL (Negative ECL), PECL (Positive ECL), LVCMOS/LVTTL, CML, or LVDS. The OLS* input is used to program the peak-to-peak output amplitude between 0 and 800 mV in five discrete steps. The RESET and SELECT inputs are single-ended and can be driven with either LVECL or LVCMOS/LVTTL input levels.

Data is transferred to the outputs on the positive edge of the clock. The differential clock inputs of the NBSG53A allow the device to also be used as a negative edge triggered device.

Features

- Maximum Input Clock Frequency (DFF) > 8 GHz Typical (See Figures 3, 5, 7, 9, and 10)
- Maximum Input Clock Frequency (DIV/2) > 10 GHz Typical (See Figures 4, 6, 8, 9, and 10)
- 210 ps Typical Propagation Delay (OLS = FLOAT)
- 45 ps Typical Rise and Fall Times (OLS = FLOAT)
- DIV/2 Mode (Active with Select Low)
- DFF Mode (Active with Select High)
- Selectable Swing PECL Output with Operating Range: $V_{CC} = 2.375$ V to 3.465 V with $V_{EE} = 0$ V
- Selectable Swing NECL Output with NECL Inputs with Operating Range: $V_{CC} = 0$ V with $V_{EE} = -2.375$ V to -3.465 V
- Selectable Output Level (0 V, 200 mV, 400 mV, 600 mV, or 800 mV Peak-to-Peak Output)
- 50 Ω Internal Input Termination Resistors on all Differential Inputs
- These are Pb-Free Devices

*Output Level Select



ON Semiconductor®

<http://onsemi.com>



QFN-16
MN SUFFIX
CASE 485G

MARKING DIAGRAM*

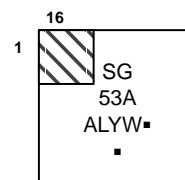

A = Assembly Location
L = Wafer Lot
Y = Year
W = Work Week
▪ = Pb-Free Package

(Note: Microdot may be in either location)

*For additional marking information, refer to Application Note AND8002/D.

ORDERING INFORMATION

See detailed ordering and shipping information in the package dimensions section on page 16 of this data sheet.

NBSG53A

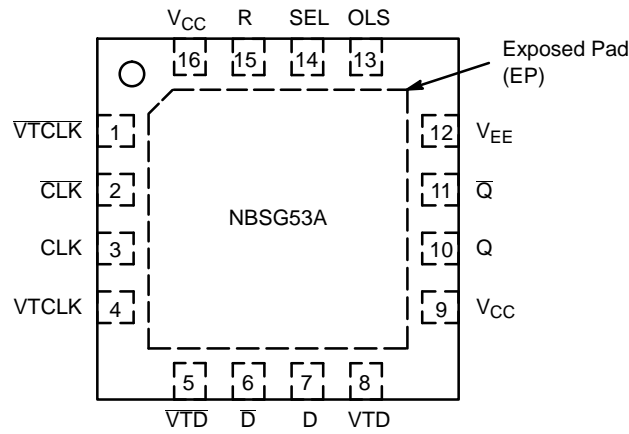

Figure 1. QFN-16 Pinout (Top View)

Table 1. PIN DESCRIPTION

Pin	Name	I/O	Description
1	\overline{VTCLK}	–	Internal 50 Ω Termination Pin. See Table 4.
2	\overline{CLK}	ECL, CML, LVCMOS, LVDS, LVTTTL Input	Inverted Differential Input.
3	CLK	ECL, CML, LVCMOS, LVDS, LVTTTL Input	Noninverted Differential Input.
4	VTCLK	–	Internal 50 Ω Termination Pin. See Table 4.
5	\overline{VTD}	–	Internal 50 Ω termination pin. See Table 4.
6	\overline{D}	ECL, CML, LVCMOS, LVDS, LVTTTL Input	Inverted Differential Input.
7	D	ECL, CML, LVCMOS, LVDS, LVTTTL Input	Noninverted Differential Input.
8	VTD	–	Internal 50 Ω Termination Pin. See Table 4.
9,16	V_{CC}	–	Positive Supply Voltage
10	Q	RSECL Output	NonInverted Differential Output. Typically Terminated with 50 Ω Resistor to $V_{TT} = V_{CC} - 2V$.
11	\overline{Q}	RSECL Output	Inverted Differential Output. Typically Terminated with 50 Ω Resistor to $V_{TT} = V_{CC} - 2V$.
12	V_{EE}	–	Negative Supply Voltage
13	OLS*	Input	Input Pin for the Output Level Select (OLS). See Table 2.
14	SEL	LVECL, LVCMOS, LVTTTL Input	Select Logic Input. Internal 75 k Ω to V_{EE} .
15	R	LVECL, LVCMOS, LVTTTL Input	Reset D Flip-Flop. Internal 75 k Ω to V_{EE} .
–	EP		The Exposed Pad (EP) on the QFN-16 package bottom is thermally connected to the die for improved heat transfer out of package. The exposed pad must be attached to a heat-sinking conduit. The pad is not electrically connected to the die but may be electrically and thermally connected to V_{EE} on the PC board.

1. All V_{CC} and V_{EE} pins must be externally connected to Power Supply to guarantee proper operation. The thermally exposed pad (EP) on package bottom (see case drawing) must be attached to a heat-sinking conduit.
2. In the differential configuration when the input termination pins (\overline{VTD} , \overline{VTD} , \overline{VTCLK} , \overline{VTCLK}) are connected to a common termination voltage, and if no signal is applied then the device will be susceptible to self-oscillation.
3. When an output level of 400 mV is desired and $V_{CC} - V_{EE} > 3.0V$, 2 k Ω resistor should be connected from OLS pin to V_{EE} .

NBSG53A

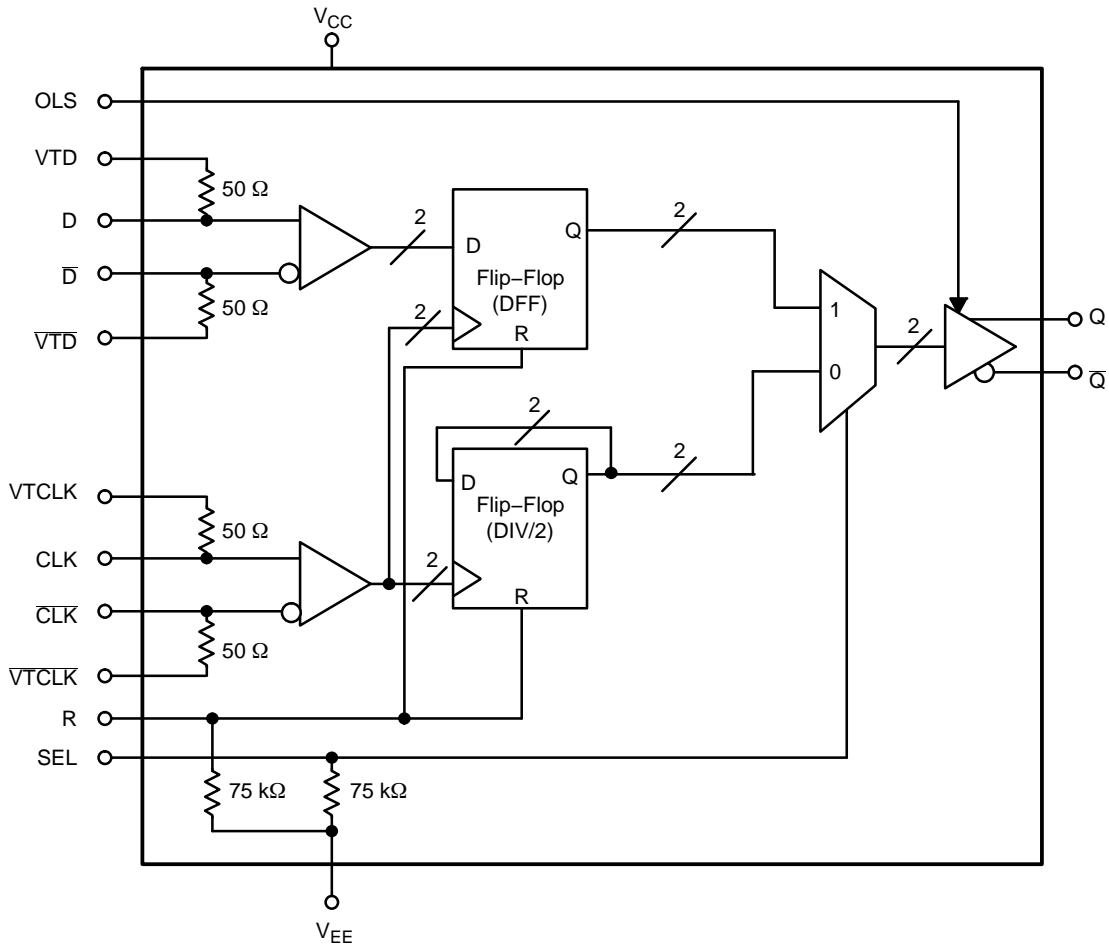

Figure 2. Simplified Logic Diagram

Table 2. OUTPUT LEVEL SELECT (OLS)

OLS	Q/Q̄ VPP	OLS Sensitivity
V _{CC}	800 mV	OLS - 75 mV
V _{CC} - 0.4 V	200 mV	OLS ± 150 mV
V _{CC} - 0.8 V	600 mV	OLS ± 100 mV
V _{CC} - 1.2 V	0	OLS ± 75 mV
V _{EE} (Note 4)	400 mV	OLS + 100 mV
Float	600 mV	N/A

4. When an output level of 400 mV is desired and V_{CC} - V_{EE} > 3.0 V, 2.0 kΩ resistor should be connected from OLS to V_{EE}.

Table 3. TRUTH TABLE

R	SEL	D	CLK	Q	Function
H	x	x	x	L	Reset
L	H	L	Z	L	DFF
L	H	H	Z	H	DFF
L	L	x	Z	Q̄	DIV/2

Z = LOW to HIGH Transition

Table 4. INTERFACING OPTIONS

INTERFACING OPTIONS	CONNECTIONS
CML	Connect VTCLK, VTD and VTCLK, VTD to V _{CC}
LVDS	Connect VTCLK, VTD and VTCLK, VTD Together
AC-COUPLED	Bias VTCLK, VTD and VTCLK, VTD Inputs within Common Mode Range (V _{IHCMR})
RSECL, PECL, NECL	Standard ECL Termination Techniques
LVTTL, LVCMOS	An External Voltage (V _{th}) should be Applied to the Unused Complementary Differential Input. Nominal V _{th} is 1.5 V for LVTTL and V _{CC} /2 for LVCMOS Inputs. This Voltage must be within the V _{th} Specification.

NBSG53A

Table 5. ATTRIBUTES

Characteristics	Value
Positive Operating Voltage Range for V_{CC} ($V_{EE} = 0$ V)	2.375 V to 3.465 V
Negative Operating Voltage Range for V_{EE} ($V_{CC} = 0$ V)	-2.375 V to -3.465 V
Internal Input Pulldown Resistor (R, SEL)	75 k Ω
ESD Protection	Human Body Model Machine Model Charged Device Model
	> 1.5 kV > 50 V > 4 kV
Moisture Sensitivity (Note 5)	Level 1
Flammability Rating	UL 94 V-0 @ 0.125 in
Oxygen Index	28 to 34
Transistor Count	482
Meets or exceeds JEDEC Spec EIA/JESD78 IC Latchup Test	

5. For additional information, refer to Application Note AND8003/D.

Table 6. MAXIMUM RATINGS

Symbol	Parameter	Condition 1	Condition 2	Rating	Units
V_{CC}	Positive Power Supply	$V_{EE} = 0$ V		3.6	V
V_{EE}	Negative Power Supply	$V_{CC} = 0$ V		-3.6	V
V_I	Positive Input Negative Input	$V_{EE} = 0$ V $V_{CC} = 0$ V	$V_I \leq V_{CC}$ $V_I \geq V_{EE}$	3.6 -3.6	V
V_{INPP}	Differential Input Voltage $ D - \bar{D} $	$V_{CC} - V_{EE} \geq 2.8$ V $V_{CC} - V_{EE} < 2.8$ V		2.8 $ V_{CC} - V_{EE} $	V
I_{IN}	Input Current Through R_T (50 Ω Resistor)	Static Surge		45 80	mA
I_{OUT}	Output Current	Continuous Surge		25 50	mA
T_A	Operating Temperature Range			-40 to +85	$^{\circ}$ C
T_{stg}	Storage Temperature Range			-65 to +150	$^{\circ}$ C
θ_{JA}	Thermal Resistance (Junction-to-Ambient) (Note 6)	0 lfpm 500 lfpm		41.6 35.2	$^{\circ}$ C/W
θ_{JC}	Thermal Resistance (Junction-to-Case)	2S2P (Note 6)		4.0	$^{\circ}$ C/W
T_{sol}	Wave Solder Pb-Free	< 3 sec @ 260 $^{\circ}$ C		265	$^{\circ}$ C

Stresses exceeding those listed in the Maximum Ratings table may damage the device. If any of these limits are exceeded, device functionality should not be assumed, damage may occur and reliability may be affected.

6. JEDEC standard multilayer board – 2S2P (2 signal, 2 power) with 8 filled thermal vias under exposed pad.

NBSG53A

Table 7. DC CHARACTERISTICS, INPUT WITH PECL OUTPUT ($V_{CC} = 2.5\text{ V}$; $V_{EE} = 0\text{ V}$) (Note 7)

Symbol	Characteristic	-40°C			25°C			85°C			Unit
		Min	Typ	Max	Min	Typ	Max	Min	Typ	Max	

POWER SUPPLY CURRENT

I_{EE}	Negative Power Supply Current	33	45	57	33	45	57	33	45	57	mA
----------	-------------------------------	----	----	----	----	----	----	----	----	----	----

PECL OUTPUTS (Note 8)

V_{OH}	Output HIGH Voltage	1460	1510	1560	1490	1540	1590	1515	1565	1615	mV
V_{OL}	Output LOW Voltage										mV
	(OLS = V_{CC})	555	705	855	595	745	895	625	775	925	
	(OLS = $V_{CC} - 0.4\text{ V}$)	1235	1295	1385	1270	1330	1420	1295	1355	1445	
	(OLS = $V_{CC} - 0.8\text{ V}$, OLS = FLOAT)	775	895	1015	810	930	1050	840	960	1080	
	(OLS = $V_{CC} - 1.2\text{ V}$)	1455	1505	1585	1490	1540	1620	1510	1560	1640	
	(OLS = V_{EE})	1005	1095	1215	1040	1130	1250	1065	1155	1275	
V_{OUTPP}	Output Voltage Amplitude										mV
	(OLS = V_{CC})	670	800		660	795		655	790		
	(OLS = $V_{CC} - 0.4\text{ V}$)	125	215		120	210		120	210		
	(OLS = $V_{CC} - 0.8\text{ V}$, OLS = FLOAT)	510	615		505	610		500	605		
	(OLS = $V_{CC} - 1.2\text{ V}$)	0	5		0	0		0	0		
	(OLS = V_{EE})	325	415		320	410		320	410		

DIFFERENTIAL CLOCK INPUTS DRIVEN SINGLE-ENDED (Figures 13 & 15) (Note 9)

V_{IH}	Input HIGH Voltage	CLK, invCLK, D, \bar{D} R, SEL	1200 1290		V_{CC} V_{CC}	1200 1355		V_{CC} V_{CC}	1200 1415		V_{CC} V_{CC}	mV
V_{IL}	Input LOW Voltage	CLK, invCLK, D, \bar{D} R, SEL	0 0		$V_{IH} - 150$ 890	0 0		$V_{IH} - 150$ 955	0 0		$V_{IH} - 150$ 1015	mV
V_{th}	Input Threshold Voltage Range (Note 10)		1125		$V_{CC} - 75$	1125		$V_{CC} - 75$	1125		$V_{CC} - 75$	mV
V_{ISE}	Single-Ended Input Voltage ($V_{IH} - V_{IL}$)		150		2600	150		2600	150		260	mV

DIFFERENTIAL INPUTS DRIVEN DIFFERENTIALLY (Figures 14 & 16) (Note 11)

V_{IHD}	Differential Input HIGH Voltage		1200		V_{CC}	1200		V_{CC}	1200		V_{CC}	mV
V_{ILD}	Differential Input LOW Voltage		0		$V_{IHD} - 75$	0		$V_{IHD} - 75$	0		$V_{IHD} - 75$	mV
V_{ID}	Differential Input Voltage ($V_{IHD} - V_{ILD}$)		75		2600	75		2600	75		2600	mV
V_{IHCMR}	Input HIGH Voltage Common Mode Range (Note 12) (Figure 17)		1200		2500	1200		2500	1200		2500	mV
I_{IH}	Input HIGH Current (@ V_{IH}) R, SEL CLK, inv_CLK, D, inv_D		35 5	100 50		35 5	100 50		35 5	100 50	μA	
I_{IL}	Input LOW Current (@ V_{IL}) R, SEL CLK, inv_CLK, D, inv_D		20 5	100 50		20 5	100 50		20 5	100 50	μA	

TERMINATION RESISTORS

R_{TIN}	Internal Input Termination Resistor	45	50	55	45	50	55	45	50	55	Ω
-----------	-------------------------------------	----	----	----	----	----	----	----	----	----	----------

Product parametric performance is indicated in the Electrical Characteristics for the listed test conditions, unless otherwise noted. Product performance may not be indicated by the Electrical Characteristics if operated under different conditions.

NOTE: Device will meet the specifications after thermal equilibrium has been established when mounted in a test socket or printed circuit board with maintained transverse airflow greater than 500 lfm. Electrical parameters are guaranteed only over the declared operating temperature range. Functional operation of the device exceeding these conditions is not implied. Device specification limit values are applied individually under normal operating conditions and not valid simultaneously.

- Input and output parameters vary 1:1 with V_{CC} .
- All outputs loaded with $50\ \Omega$ to $V_{CC} - 2.0\text{ V}$.
- V_{th} , V_{IH} , V_{IL} , and V_{ISE} parameters must be complied with simultaneously.
- V_{th} is applied to the complementary input when operating in single-ended mode. $V_{th} = (V_{IH} - V_{IL}) / 2$.
- V_{IHD} , V_{ILD} , V_{ID} and V_{IHCMR} parameters must be complied with simultaneously.
- V_{IHCMR} min varies 1:1 with V_{EE} , V_{IHCMR} max varies 1:1 with V_{CC} . The V_{IHCMR} range is referenced to the most positive side of the differential input signal.

NBSG53A

Table 8. DC CHARACTERISTICS, INPUT WITH PECL OUTPUT ($V_{CC} = 3.3\text{ V}$; $V_{EE} = 0\text{ V}$) (Note 13)

Symbol	Characteristic	-40°C			25°C			85°C			Unit
		Min	Typ	Max	Min	Typ	Max	Min	Typ	Max	

POWER SUPPLY CURRENT

I_{EE}	Negative Power Supply Current	35	47	59	35	47	59	35	47	59	mA
----------	-------------------------------	----	----	----	----	----	----	----	----	----	----

PECL OUTPUTS (Note 14)

V_{OH}	Output HIGH Voltage	2260	2310	2360	2290	2340	2390	2315	2365	2415	mV
V_{OL}	Output LOW Voltage										mV
	(OLS = V_{CC})	1320	1470	1620	1360	1510	1660	1390	1540	1690	
	(OLS = $V_{CC} - 0.4\text{ V}$)	2030	2090	2180	2065	2125	2215	2090	2150	2240	
	(OLS = $V_{CC} - 0.8\text{ V}$, OLS = FLOAT)	1550	1670	1790	1585	1705	1825	1615	1735	1855	
	(OLS = $V_{CC} - 1.2\text{ V}$)	2260	2310	2390	2290	2340	2420	2315	2365	2445	
	** (OLS = V_{EE})	1785	1875	1995	1820	2030	2030	1850	1940	2060	
V_{OUTPP}	Output Voltage Amplitude										mV
	(OLS = V_{CC})	705	815		695	805		590	800		
	(OLS = $V_{CC} - 0.4\text{ V}$)	130	220		125	215		125	215		
	(OLS = $V_{CC} - 0.8\text{ V}$, OLS = FLOAT)	535	640		530	635		525	630		
	(OLS = $V_{CC} - 1.2\text{ V}$)	0	0		0	0		0	0		
	** (OLS = V_{EE})	345	435		340	430		335	425		

DIFFERENTIAL CLOCK INPUTS DRIVEN SINGLE-ENDED (Figures 13 & 15) (Note 15)

V_{IH}	Input HIGH Voltage (Single-Ended)	1200		V_{CC}	1200		V_{CC}	1200		V_{CC}	mV
	CLK, invCLK, D, \bar{D} R, SEL	2090		V_{CC}	2155		V_{CC}	2215		V_{CC}	
V_{IL}	Input LOW Voltage (Single-Ended)	0		$V_{IH} - 150$	0		$V_{IH} - 150$	0		$V_{IH} - 150$	mV
	CLK, invCLK, D, \bar{D} R, SEL	0		1690	0		1755	0		1815	
V_{th}	Input Threshold Voltage Range (Note 16)	1125		$V_{CC} - 75$	1125		$V_{CC} - 75$	1125		$V_{CC} - 75$	mV
V_{ISE}	Single-Ended Input Voltage ($V_{IH} - V_{IL}$)	150		2600	150		2600	150		260	mV

DIFFERENTIAL INPUTS DRIVEN DIFFERENTIALLY (Figures 14 & 16) (Note 17)

V_{IHD}	Differential Input HIGH Voltage	1200		V_{CC}	1200		V_{CC}	1200		V_{CC}	mV
V_{ILD}	Differential Input LOW Voltage	0		$V_{IHD} - 75$	0		$V_{IHD} - 75$	0		$V_{IHD} - 75$	mV
V_{ID}	Differential Input Voltage ($V_{IHD} - V_{ILD}$)	75		2600	75		2600	75		2600	mV
V_{IHCMR}	Input HIGH Voltage Common Mode Range (Note 18) (Figure 17)	1200		3300	1200		3300	1200		3300	mV
I_{IH}	Input HIGH Current (@ V_{IH})		35	100		35	100		35	100	μA
	CLK, inv_CLK, D, inv_D R, SEL		5	50		5	50		5	50	
I_{IL}	Input LOW Current (@ V_{IL})		20	100		20	100		20	100	μA
	CLK, inv_CLK, D, inv_D R, SEL		5	50		5	50		5	50	

TERMINATION RESISTORS

R_{TIN}	Internal Input Termination Resistor	45	50	55	45	50	55	45	50	55	Ω
-----------	-------------------------------------	----	----	----	----	----	----	----	----	----	----------

Product parametric performance is indicated in the Electrical Characteristics for the listed test conditions, unless otherwise noted. Product performance may not be indicated by the Electrical Characteristics if operated under different conditions.

NOTE: Device will meet the specifications after thermal equilibrium has been established when mounted in a test socket or printed circuit board with maintained transverse airflow greater than 500 lfm. Electrical parameters are guaranteed only over the declared operating temperature range. Functional operation of the device exceeding these conditions is not implied. Device specification limit values are applied individually under normal operating conditions and not valid simultaneously.

**When an output level of 400 mV is desired and $V_{CC} - V_{EE} > 3.0\text{ V}$, a 2 k Ω resistor should be connected from OLS to V_{EE} .

13. Input and output parameters vary 1:1 with V_{CC} .

14. All outputs loaded with 50 Ω to $V_{CC} - 2.0\text{ V}$.

15. V_{th} , V_{IH} , V_{IL} , and V_{ISE} parameters must be complied with simultaneously.

16. V_{th} is applied to the complementary input when operating in single-ended mode. $V_{th} = (V_{IH} - V_{IL}) / 2$.

17. V_{IHD} , V_{ILD} , V_{ID} and V_{IHCMR} parameters must be complied with simultaneously.

18. V_{IHCMR} min varies 1:1 with V_{EE} , V_{IHCMR} max varies 1:1 with V_{CC} . The V_{IHCMR} range is referenced to the most positive side of the differential input signal.

NBSG53A

Table 9. DC CHARACTERISTICS, NECL INPUT WITH NECL OUTPUT

($V_{CC} = 0\text{ V}$; $V_{EE} = -3.465\text{ V}$ to -2.375 V) (Note 19)

Symbol	Characteristic	-40°C			25°C			85°C			Unit
		Min	Typ	Max	Min	Typ	Max	Min	Typ	Max	

POWER SUPPLY CURRENT

I_{EE}	Negative Power Supply Current	35	47	59	35	47	59	35	47	59	mA
----------	-------------------------------	----	----	----	----	----	----	----	----	----	----

NECL OUTPUTS (Note 20)

V_{OH}	Output HIGH Voltage	-1040	-990	-940	-1010	-960	-910	-985	-935	-885	mV
V_{OL}	Output LOW Voltage										mV
	$-3.465\text{ V} \leq V_{EE} \leq -3.0\text{ V}$										
	(OLS = V_{CC})	-1980	-1830	-1680	-1940	-1790	-1640	-1910	-1760	-1610	
	(OLS = $V_{CC} - 0.4\text{ V}$)	-1270	-1210	-1120	-1235	-1175	-1085	-1210	-1150	-1060	
	(OLS = $V_{CC} - 0.8\text{ V}$, OLS = FLOAT)	-1750	-1630	-1510	-1715	-1595	-1475	-1685	-1565	-1445	
	(OLS = $V_{CC} - 1.2\text{ V}$)	-1040	-990	-910	-1010	-960	-880	-985	-935	-855	
	** (OLS = V_{EE})	-1515	-1425	-1305	-1480	-1390	-1270	-1450	-1360	-1240	
	$-3.0\text{ V} < V_{EE} \leq -2.375\text{ V}$										
	(OLS = V_{CC})	-1945	-1795	-1645	-1905	-1755	-1605	-1875	-1725	-1575	
	(OLS = $V_{CC} - 0.4\text{ V}$)	-1265	-1205	-1115	-1230	-1170	-1080	-1205	-1145	-1055	
	(OLS = $V_{CC} - 0.8\text{ V}$, OLS = FLOAT)	-1725	-1605	-1485	-1690	-1570	-1450	-1660	-1540	-1420	
	(OLS = $V_{CC} - 1.2\text{ V}$)	-1045	-995	-915	-1010	-960	-880	-900	-940	-860	
(OLS = V_{EE})	-1495	-1405	-1285	-1460	-1370	-1250	-1435	-1345	-1225		
V_{OUTPP}	Output Voltage Amplitude										mV
	$-3.465\text{ V} \leq V_{EE} \leq -3.0\text{ V}$										
	(OLS = V_{CC})	705	815		695	805		690	800		
	(OLS = $V_{CC} - 0.4\text{ V}$)	130	220		125	215		125	215		
	(OLS = $V_{CC} - 0.8\text{ V}$, OLS = FLOAT)	535	640		530	635		525	630		
	(OLS = $V_{CC} - 1.2\text{ V}$)	0	0		0	0		0	0		
	** (OLS = V_{EE})	345	435		340	430		335	425		
	$-3.0\text{ V} < V_{EE} \leq -2.375\text{ V}$										
	(OLS = V_{CC})	670	800		660	795		655	790		
	(OLS = $V_{CC} - 0.4\text{ V}$)	125	215		120	210		120	210		
	(OLS = $V_{CC} - 0.8\text{ V}$, OLS = FLOAT)	510	615		505	610		500	605		
	(OLS = $V_{CC} - 1.2\text{ V}$)	0	5		0	0		0	5		
(OLS = V_{EE})	325	415		320	410		320	410			

DIFFERENTIAL CLOCK INPUTS DRIVEN SINGLE-ENDED (Figures 13 & 15) (Note 21)

V_{IH}	Input HIGH Voltage (Single-Ended) CLK, invCLK, D, \bar{D} R, SEL	$V_{EE} + 1200$ -1210		V_{CC} V_{CC}	$V_{EE} + 1200$ -1145		V_{CC} V_{CC}	$V_{EE} + 1200$ -1085		V_{CC} V_{CC}	mV
V_{IL}	Input LOW Voltage (Single-Ended) CLK, invCLK, D, \bar{D} R, SEL	V_{EE} V_{EE}		$V_{IH} - 150$ -1690	V_{EE} V_{EE}		$V_{IH} - 150$ -1545	V_{EE} V_{EE}		$V_{IH} - 150$ -1485	mV
V_{th}	Input Threshold Voltage (Note 22)	$V_{EE} + 1125$		$V_{CC} - 75$	$V_{EE} + 1125$		$V_{CC} - 75$	$V_{EE} + 1125$		$V_{CC} - 75$	mV
V_{ISE}	Single-Ended Input Voltage ($V_{IH} - V_{IL}$)	150		2600	150		2600	150		260	mV

DIFFERENTIAL INPUTS DRIVEN DIFFERENTIALLY (Figures 14 & 16) (Note 23)

V_{IHD}	Differential Input HIGH Voltage	$V_{EE} + 1200$		V_{CC}	$V_{EE} + 1200$		V_{CC}	$V_{EE} + 1200$		V_{CC}	mV
V_{ILD}	Differential Input LOW Voltage	V_{EE}		$V_{IHD} - 75$	V_{EE}		$V_{IHD} - 75$	V_{EE}		$V_{IHD} - 75$	mV
V_{ID}	Differential Input Voltage ($V_{IHD} - V_{ILD}$)	75		2600	75		2600	75		2600	mV
V_{IHCMR}	Input HIGH Voltage Common Mode Range (Differential Configuration) (Note 24) (Figure 17)	$V_{EE} + 1200$		0.0	$V_{EE} + 1200$		0.0	$V_{EE} + 1200$		0.0	mV
I_{IH}	Input HIGH Current (@ V_{IH}) R, SEL CLK, inv_CLK, D, inv_D		35 5	100 50		35 5	100 50		35 5	100 50	μA

NBSG53A

Table 9. DC CHARACTERISTICS, NECL INPUT WITH NECL OUTPUT (continued)

($V_{CC} = 0\text{ V}$; $V_{EE} = -3.465\text{ V}$ to -2.375 V) (Note 19)

Symbol	Characteristic	-40°C			25°C			85°C			Unit
		Min	Typ	Max	Min	Typ	Max	Min	Typ	Max	
DIFFERENTIAL INPUTS DRIVEN DIFFERENTIALLY (Figures 14 & 16) (Note 23)											
I_{IL}	Input LOW Current (@ V_{IL}) R, SEL CLK, inv_CLK, D, inv_D		20 5	100 50		20 5	100 50		20 5	100 50	μA
I_{OLS}	OLS Input Current (see Figure 11) (OLS = V_{CC}) (OLS = $V_{CC} - 0.4\text{ V}$) (OLS = $V_{CC} - 0.8\text{ V}$, OLS = FLOAT) (OLS = $V_{CC} - 1.2\text{ V}$) $-3.465\text{ V} \leq V_{EE} \leq -3.0\text{ V}$ *(OLS = V_{EE}) $-3.0\text{ V} < V_{EE} \leq -2.375\text{ V}$ (OLS = V_{EE})		300 100 5 -100 -1500 -1000	900 300 100 -100 -600 -400		300 100 5 -100 -1500 -1000	900 300 100 -100 -600 -400		300 100 5 -100 -1500 -1000	900 300 100 -100 -600 -400	μA

TERMINATION RESISTORS

R_{TIN}	Internal Input Termination Resistor	45	50	55	45	50	55	45	50	55	Ω

Product parametric performance is indicated in the Electrical Characteristics for the listed test conditions, unless otherwise noted. Product performance may not be indicated by the Electrical Characteristics if operated under different conditions.

NOTE: Device will meet the specifications after thermal equilibrium has been established when mounted in a test socket or printed circuit board with maintained transverse airflow greater than 500 lfm. Electrical parameters are guaranteed only over the declared operating temperature range. Functional operation of the device exceeding these conditions is not implied. Device specification limit values are applied individually under normal operating conditions and not valid simultaneously.

*Typicals used for testing purposes.

**When an output level of 400 mV is desired and $V_{CC} - V_{EE} > 3.0\text{ V}$, a 2 k Ω resistor should be connected from OLS to V_{EE} .

19. Input and output parameters vary 1:1 with V_{CC} .

20. All outputs loaded with 50 Ω to $V_{CC} - 2.0\text{ V}$.

21. V_{th} , V_{IH} , V_{IL} , and V_{ISE} parameters must be complied with simultaneously.

22. V_{th} is applied to the complementary input when operating in single-ended mode. $V_{th} = (V_{IH} - V_{IL}) / 2$.

23. V_{IHD} , V_{ILD} , V_{ID} and V_{IHCMR} parameters must be complied with simultaneously.

24. V_{IHCMR} min varies 1:1 with V_{EE} , V_{IHCMR} max varies 1:1 with V_{CC} . The V_{IHCMR} range is referenced to the most positive side of the differential input signal.

NBSG53A

Table 10. AC CHARACTERISTICS

($V_{CC} = 0\text{ V}$; $V_{EE} = -3.465\text{ V}$ to -2.375 V or $V_{CC} = 2.375\text{ V}$ to 3.465 V ; $V_{EE} = 0\text{ V}$)

Symbol	Characteristic	-40°C			25°C			85°C			Unit
		Min	Typ	Max	Min	Typ	Max	Min	Typ	Max	
f_{max}	Maximum Input Clock Frequency (See Figures 3, 5, 7, 9, and 10) DFF (See Figures 4, 6, 8, 9, and 10) (Note 25) DIV/2		8		8		8		8		GHz
t_{PLH} , t_{PHL}	Propagation Delay to Output Differential (Note 29) CLK→Q, \bar{Q} SEL→Q, \bar{Q} R→Q, \bar{Q} $D_{IN}/2$ DFF	150 100 215 195	215 190 280 270	285 280 375 345	150 100 215 195	215 190 280 270	285 280 375 345	150 100 215 195	215 190 280 270	285 280 375 345	ps
t_{SKEW}	Duty Cycle Skew (Notes 26 and 28) DFF		5	20		5	20		5	20	ps
t_{JITTER}	RMS Random Clock Jitter $f_{in} \leq 8\text{ GHz}$ (See Figures 3 and 5) (Note 25) Peak-to-Peak Data Dependent Jitter $f_{in} = 8\text{ Gb/s}$		0.5	1		0.5	1		0.5	1	ps
V_{INPP}	Input Voltage Swing/Sensitivity (Differential Configuration) (Note 27)	75		2600	75		2600	75		2600	mV
t_r t_f	Output Rise/Fall Times (20% – 80%) @ 1 GHz Q, \bar{Q} (OLS = V_{CC}) (OLS = $V_{CC} - 0.4\text{ V}$) (OLS = $V_{CC} - 0.8\text{ V}$, OLS = FLOAT) **(OLS = V_{EE})	28 15 25 20	40 40 35 35	65 65 65 65	28 15 25 20	40 40 35 35	65 65 65 65	28 15 25 20	40 40 35 35	65 65 65 65	ps
t_s	Setup Time D→CLK	30	14		30	10		30	13		ps
t_h	Hold Time D→CLK	25	12		25	7		25	0		ps
t_{rr}	Reset Recovery DFF, DIV/2	40	9		40	12		40	10		ps

NOTE: Device will meet the specifications after thermal equilibrium has been established when mounted in a test socket or printed circuit board with maintained transverse airflow greater than 500 lfm. Electrical parameters are guaranteed only over the declared operating temperature range. Functional operation of the device exceeding these conditions is not implied. Device specification limit values are applied individually under normal operating conditions and not valid simultaneously.

25. Measured using a 500 mV source, 50% duty cycle clock source. Repetitive 1010 input data pattern. All outputs loaded with 50 Ω to $V_{CC} - 2.0\text{ V}$. Input edge rates is 40 ps (20% – 80%).

26. See Figure 18. $t_{SKEW} = |t_{PLH} - t_{PHL}|$ for a nominal 50% differential clock input waveform.

27. V_{INPP} (MAX) cannot exceed $V_{CC} - V_{EE}$ (Applicable only when $V_{CC} - V_{EE} < 2600\text{ mV}$).

28. See Figure 9. Duty Cycle % vs. Frequency.

29. For all OLS Configuration.

**When an output level of 400 mV is desired and $V_{CC} - V_{EE} > 3.0\text{ V}$, a 2 k Ω resistor should be connected from OLS to V_{EE} .

NBSG53A

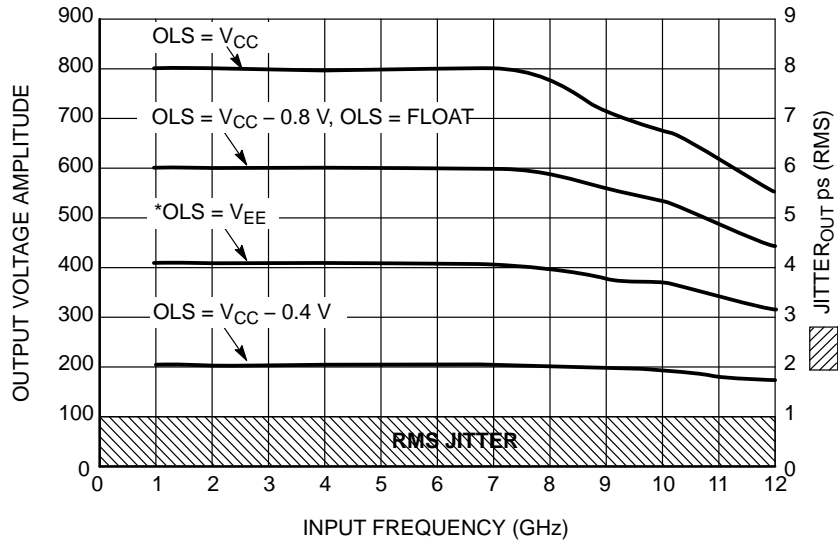

Figure 3. Output Voltage Amplitude (V_{OUTPP}) / RMS Jitter vs. Input Frequency (f_{in}) for DFF Mode ($V_{CC} - V_{EE} = 3.3V @ 25^{\circ}C$; Repetitive 1010 Input Data Pattern)

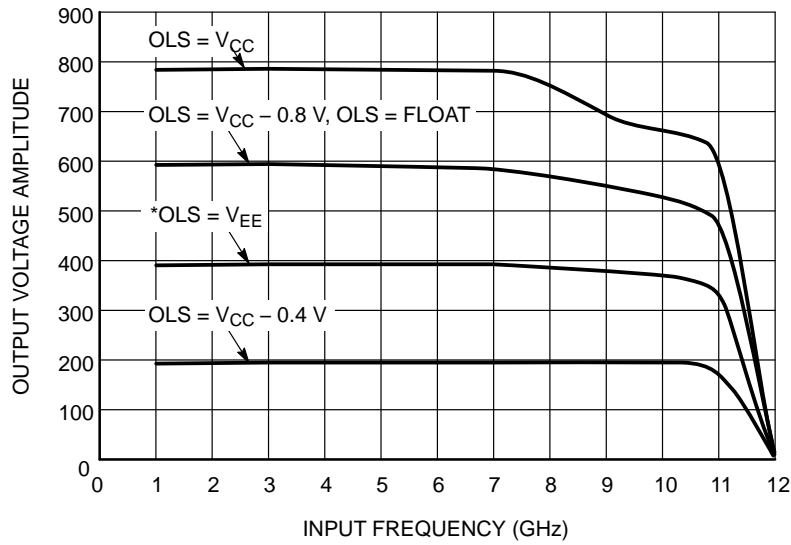

Figure 4. Output Voltage Amplitude (V_{OUTPP}) / RMS Jitter vs. Input Frequency (f_{in}) for DIV/2 Mode ($V_{CC} - V_{EE} = 3.3V @ 25^{\circ}C$)

*When an output level of 400 mV is desired and $V_{CC} - V_{EE} > 3.0V$, a $2k\Omega$ resistor should be connected from OLS to V_{EE} .

NBSG53A

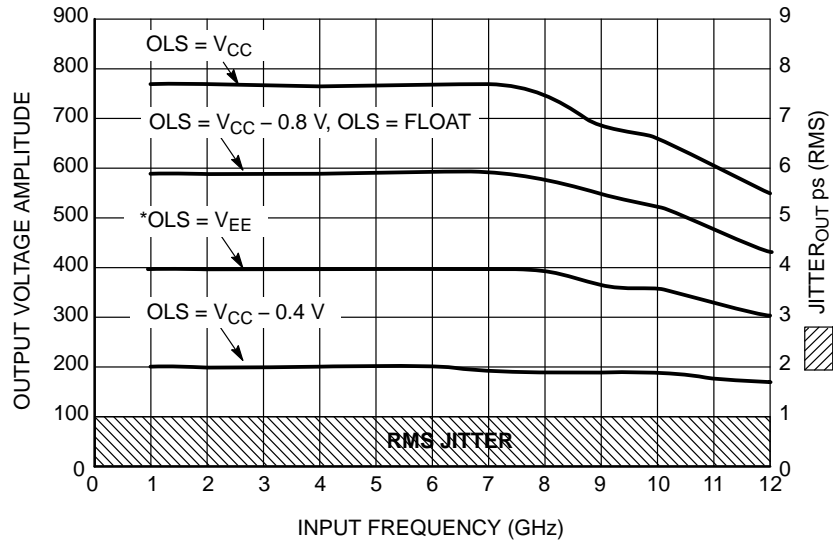

Figure 5. Output Voltage Amplitude (V_{OUTPP}) / RMS Jitter vs. Input Frequency (f_{in}) for DFF Mode ($V_{CC} - V_{EE} = 2.5\text{ V}$ @ 25°C ; Repetitive 1010 Input Data Pattern)

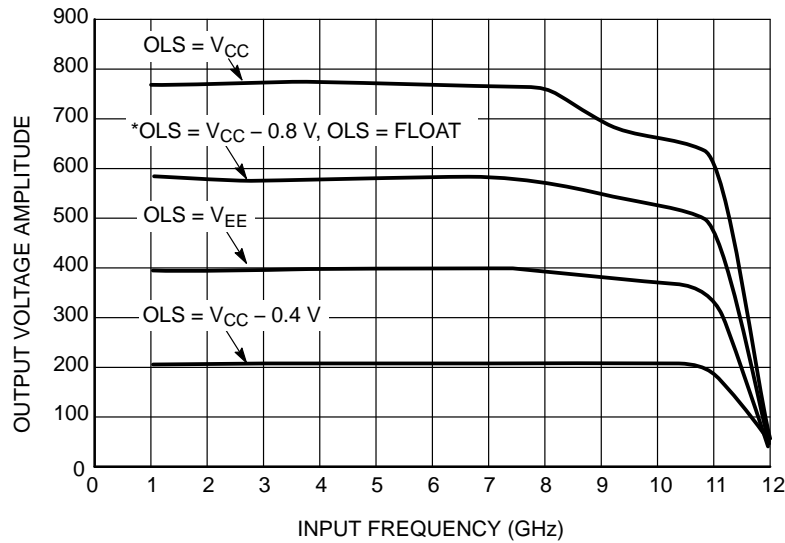

Figure 6. Output Voltage Amplitude (V_{OUTPP}) / RMS Jitter vs. Input Frequency (f_{in}) for DIV/2 Mode ($V_{CC} - V_{EE} = 2.5\text{ V}$ @ 25°C)

*When an output level of 400 mV is desired and $V_{CC} - V_{EE} > 3.0\text{ V}$, a $2\text{ k}\Omega$ resistor should be connected from OLS to V_{EE} .

NBSG53A

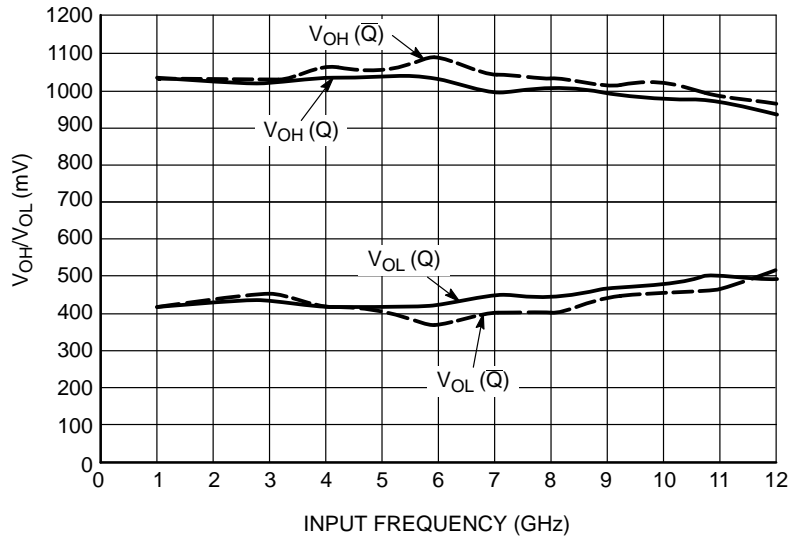

Figure 7. V_{OH}/V_{OL} (Q/ \bar{Q}) vs. Input Frequency (f_{in}) for DFF Mode ($V_{CC} - V_{EE} = 3.3$ V @ 25°C and OLS = $V_{CC} - 0.8$ V, OLS = FLOAT)

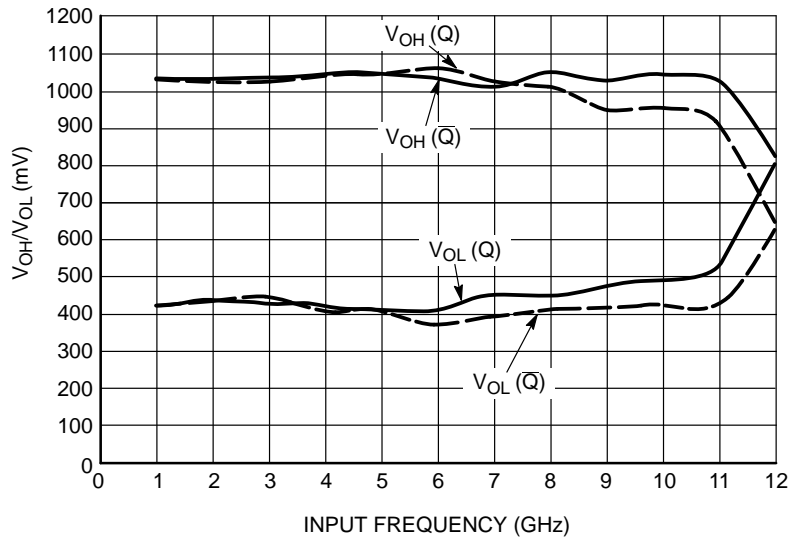

Figure 8. V_{OH}/V_{OL} (Q/ \bar{Q}) vs. Input Frequency (f_{in}) for DIV/2 Mode ($V_{CC} - V_{EE} = 3.3$ V @ 25°C and OLS = $V_{CC} - 0.8$ V, OLS = FLOAT)

NBSG53A

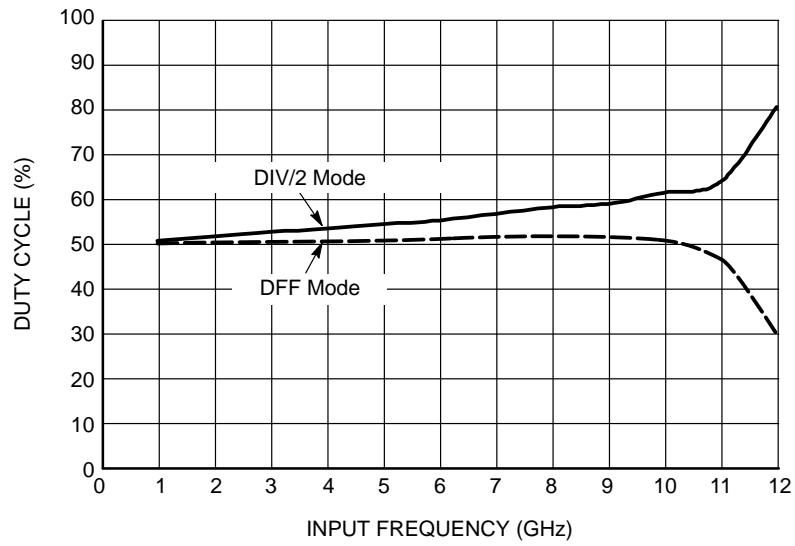

Figure 9. Duty Cycle % vs. Input Frequency (f_{in})
($V_{CC} - V_{EE} = 3.3 \text{ V @ } 25^{\circ}\text{C}$)

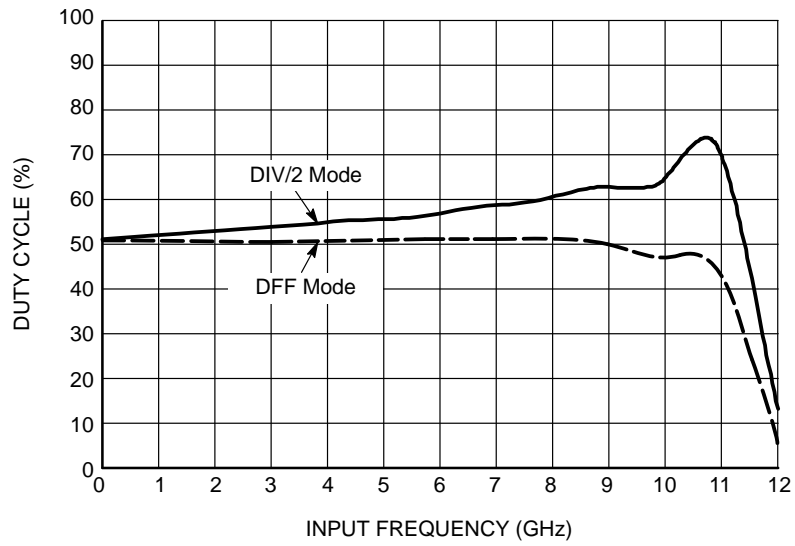

Figure 10. Duty Cycle % vs. Input Frequency (f_{in})
($V_{CC} - V_{EE} = 2.5 \text{ V @ } 70^{\circ}\text{C}$)

NBSG53A

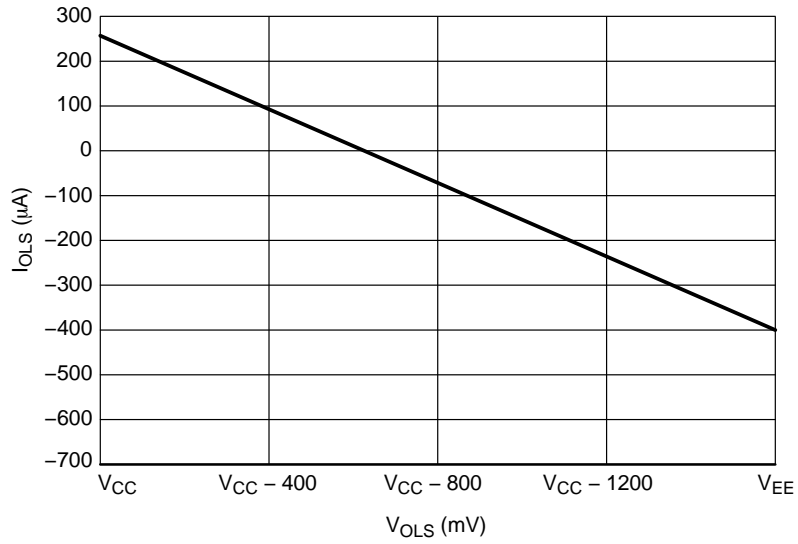

Figure 11. Typical OLS Input Current vs. OLS Input Voltage ($V_{CC} - V_{EE} = 3.3$ V @ 25°C)

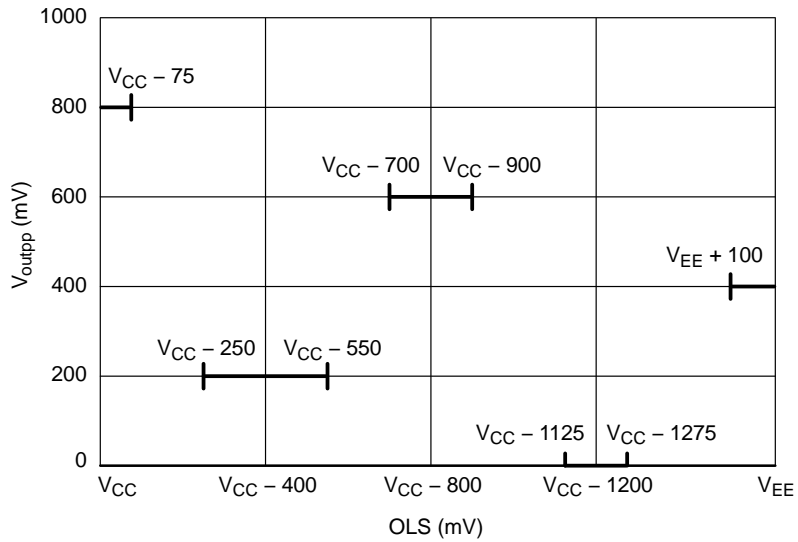

Figure 12. OLS Operating Area

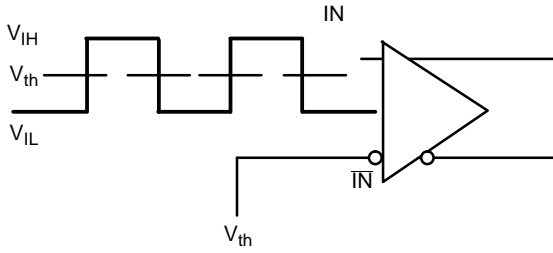

Figure 13. Differential Input Driven Single-Ended

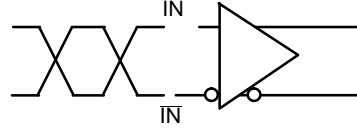

Figure 14. Differential Inputs Driven Differentially

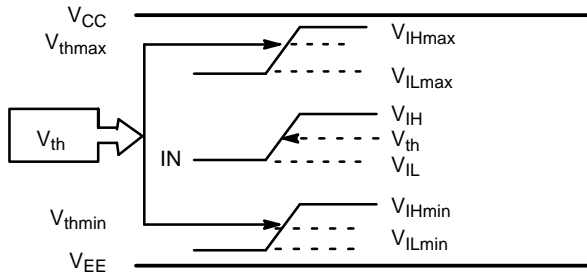

Figure 15. V_{th} Diagram

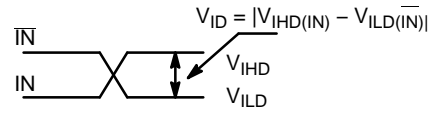

Figure 16. Differential Inputs Driven Differentially

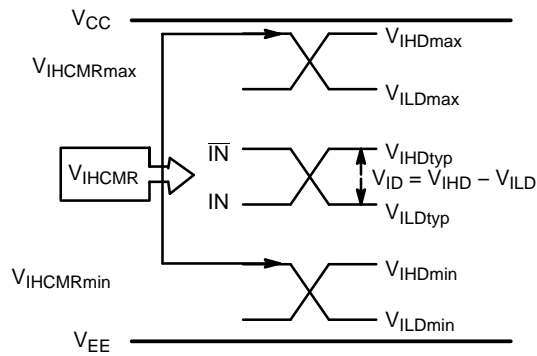

Figure 17. V_{IHCMR} Diagram

NBSG53A

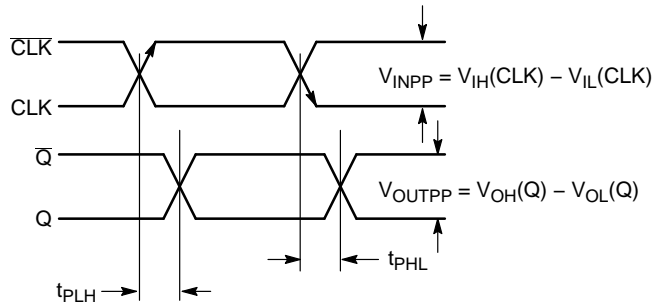

Figure 18. AC Reference Measurement

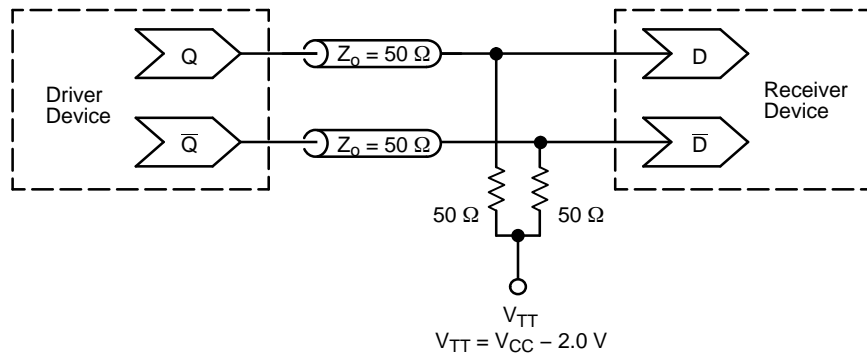

Figure 19. Typical Termination for Output Driver and Device Evaluation
(Refer to Application Note AND8020/D – Termination of ECL Logic Devices)

ORDERING INFORMATION

Device	Package Type	Shipping†
NBSG53AMNG	QFN-16, 3x3 mm (Pb-Free / Halide-Free)	123 Units / Tube
NBSG53AMNR2G	QFN-16, 3x3 mm (Pb-Free / Halide-Free)	3000 / Tape & Reel
NBSG53AMNHTBG	QFN-16 (Pb-Free / Halide-Free)	100 / Tape & Reel

†For information on tape and reel specifications, including part orientation and tape sizes, please refer to our Tape and Reel Packaging Specifications Brochure, BRD8011/D.

NBSG53A

PACKAGE DIMENSIONS

QFN16 3x3, 0.5P
CASE 485G
ISSUE F

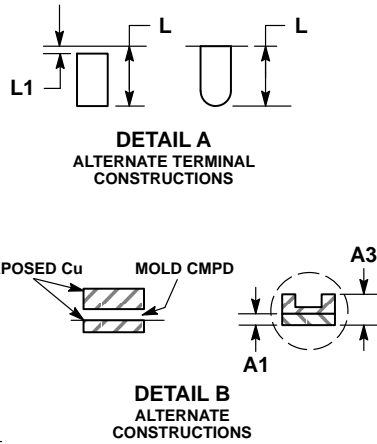
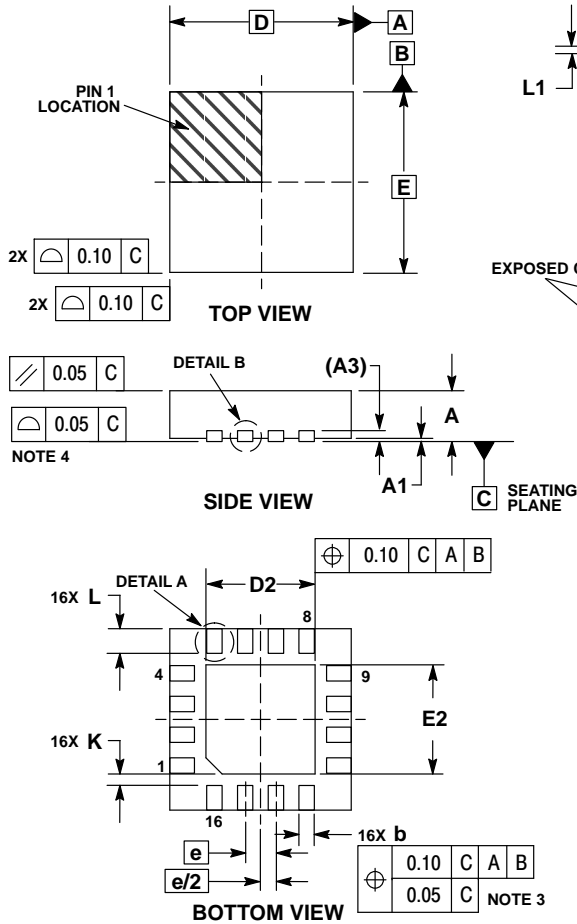

NOTES:

1. DIMENSIONING AND TOLERANCING PER ASME Y14.5M, 1994.
2. CONTROLLING DIMENSION: MILLIMETERS.
3. DIMENSION b APPLIES TO PLATED TERMINAL AND IS MEASURED BETWEEN 0.25 AND 0.30 MM FROM TERMINAL.
4. COPLANARITY APPLIES TO THE EXPOSED PAD AS WELL AS THE TERMINALS.

DIM	MILLIMETERS		
	MIN	NOM	MAX
A	0.80	0.90	1.00
A1	0.00	0.03	0.05
A3	0.20 REF		
b	0.18	0.24	0.30
D	3.00 BSC		
D2	1.65	1.75	1.85
E	3.00 BSC		
E2	1.65	1.75	1.85
e	0.50 BSC		
K	0.18 TYP		
L	0.30	0.40	0.50
L1	0.00	0.08	0.15

RECOMMENDED SOLDERING FOOTPRINT*

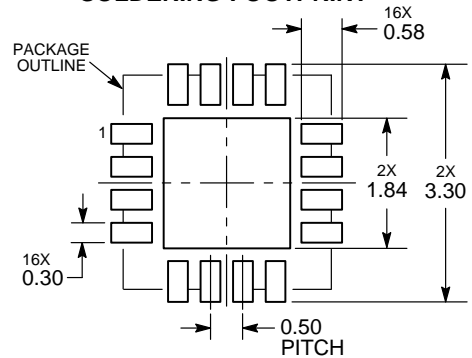

DIMENSIONS: MILLIMETERS

*For additional information on our Pb-Free strategy and soldering details, please download the ON Semiconductor Soldering and Mounting Techniques Reference Manual, SOLDERRM/D.

The products described herein (NBSG53A), may be covered by U.S. patents including 6,362,644. There may be other patents pending. GigaComm is a trademark of Semiconductor Components Industries, LLC.

ON Semiconductor and are registered trademarks of Semiconductor Components Industries, LLC (SCILLC). SCILLC owns the rights to a number of patents, trademarks, copyrights, trade secrets, and other intellectual property. A listing of SCILLC's product/patent coverage may be accessed at www.onsemi.com/site/pdf/Patent-Marking.pdf. SCILLC reserves the right to make changes without further notice to any products herein. SCILLC makes no warranty, representation or guarantee regarding the suitability of its products for any particular purpose, nor does SCILLC assume any liability arising out of the application or use of any product or circuit, and specifically disclaims any and all liability, including without limitation special, consequential or incidental damages. "Typical" parameters which may be provided in SCILLC data sheets and/or specifications can and do vary in different applications and actual performance may vary over time. All operating parameters, including "Typicals" must be validated for each customer application by customer's technical experts. SCILLC does not convey any license under its patent rights nor the rights of others. SCILLC products are not designed, intended, or authorized for use as components in systems intended for surgical implant into the body, or other applications intended to support or sustain life, or for any other application in which the failure of the SCILLC product could create a situation where personal injury or death may occur. Should Buyer purchase or use SCILLC products for any such unintended or unauthorized application, Buyer shall indemnify and hold SCILLC and its officers, employees, subsidiaries, affiliates, and distributors harmless against all claims, costs, damages, and expenses, and reasonable attorney fees arising out of, directly or indirectly, any claim of personal injury or death associated with such unintended or unauthorized use, even if such claim alleges that SCILLC was negligent regarding the design or manufacture of the part. SCILLC is an Equal Opportunity/Affirmative Action Employer. This literature is subject to all applicable copyright laws and is not for resale in any manner.

PUBLICATION ORDERING INFORMATION

LITERATURE FULFILLMENT:
Literature Distribution Center for ON Semiconductor
P.O. Box 5163, Denver, Colorado 80217 USA
Phone: 303-675-2175 or 800-344-3860 Toll Free USA/Canada
Fax: 303-675-2176 or 800-344-3867 Toll Free USA/Canada
Email: orderlit@onsemi.com

N. American Technical Support: 800-282-9855 Toll Free USA/Canada
Europe, Middle East and Africa Technical Support:
Phone: 421 33 790 2910
Japan Customer Focus Center
Phone: 81-3-5817-1050

ON Semiconductor Website: www.onsemi.com
Order Literature: <http://www.onsemi.com/orderlit>
For additional information, please contact your local Sales Representative

Looking for pricing, stock, or lifecycle information?

Click below to explore more details on WIN SOURCE:

- ⊖ [View NBSG53ABAR2 on WIN SOURCE](#)
- ⊖ [ON Semiconductor Information](#)

Optimize Your Supply Chain with WIN SOURCE Solutions

- ✓ Global Sourcing Solution
- ✓ Obsolete Management
- ✓ Cost Control Management
- ✓ Shortage Management
- ✓ Alternative Solution
- ✓ Excess Inventory Management