



THE DATASHEET OF LM158DR



Dual operational amplifier

The LM158 consists of two independent high gain operational amplifiers. It can work with a single power supply or with a dual power supply, and the current consumption of the power supply has nothing to do with the power supply voltage. Applications include variable frequency amplifiers, DC gain sections and all conventional op amp circuits.

Available in DIP8 or SOP8 packages.

main features :

- Can work with single or dual power supply
- Two internally compensated op amps in one package.
- logic circuit matching.
- Low power consumption.
- Wide frequency range

Functional Block Diagram and Pinout Diagram

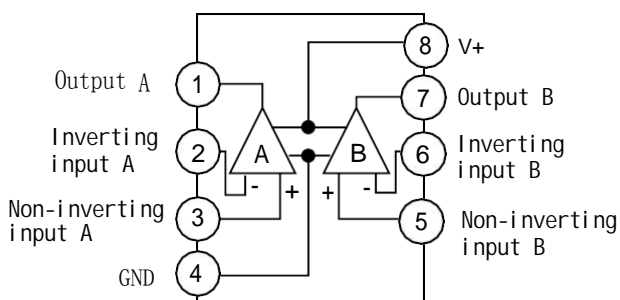

Package Outline Drawing

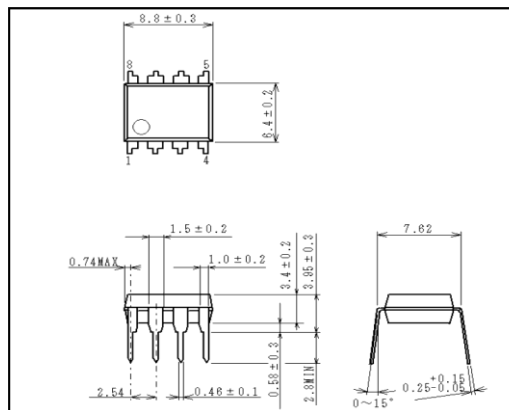

DIP-8

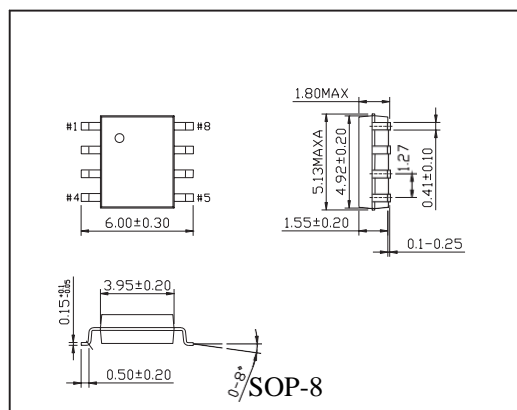

Limit value (absolute maximum rating, if not otherwise specified, Tamb=25°C)

parameter name		value	unit
voltage		32 or ± 18	V
Differential input voltage		32	V
Input voltage		-0.3~32	V
Power consumption (Note 1)	DIP package	550	mW
	SOP package	530	
Output short-circuit current to ground (1 amplifier) (Note 2) (V ⁺ ≤ 15V, Ta=25°C)		continued	
Input current (VIN < -0.3V) (Note 3)		50	mA
Working temperature		-55~125	°C
Storage temperature		-65~150	°C

Electrical characteristics (if not otherwise specified, $V^+=5.0V$)

Features	Test Conditions		Specification value			Unit
			MIN	TYP	MAX	
Input offset voltage	$T_a = 25$			2	5	mV
input bias current	$T_a = 25\text{ }^\circ\text{C}$, $I_{IN(+)}$ or $I_{IN(-)}$, $V_{CM} = 0V$			45	150	nA
Input offset current	$T_a=25\text{ }^\circ\text{C}$, $I_{IN(+)} - I_{IN(-)}$, $V_{CM}=0V$			3	30	nA
Input Common Mode Voltage Range	$T_a=25\text{ }^\circ\text{C}$, $V^+=30V$		0		$V^+-1.5$	V
supply current	Over the entire temperature range, $R_L = \infty$ on all operational amplifiers	$V^+=30V$		1	2	mA
		$V^+=5V$		0.5	1.2	
Large signal voltage gain	$V^+ = 15V$, $T_a=25\text{ }^\circ\text{C}$, $R_L \geq 2k\Omega$ (for $V_o=1\sim 11V$)		50	100		V/mV
Common Mode Rejection Ratio	DC, $T_a=25\text{ }^\circ\text{C}$, $V_{CM}=0\sim V^+-1.5V$		70	85		dB
power supply rejection ratio	DC, $T_a=25\text{ }^\circ\text{C}$, $V^+=5\sim 30V$		65	100		dB
Coupling system between amplifiers number	$T_a=25\text{ }^\circ\text{C}$, $f=1\sim 20kHz$ (all inputs)			-120		dB
Output source current	$V_{IN(+)}=1V$, $V_{IN(-)}=0V$, $V^+=15V$, $V_o=2V$, $T_a=25\text{ }^\circ\text{C}$		20	40		mA
output current sink	$V_{IN(-)}=1V$, $V_{IN(+)}=0V$, $V^+=15V$, $V_o=2V$, $T_a=25\text{ }^\circ\text{C}$		10	20		mA
	$V_{IN(-)}=1V$, $V_{IN(+)}=0V$, $V^+=15V$, $V_o=200mV$, $T_a=25\text{ }^\circ\text{C}$		12	50		μA
short-circuit current to ground	$V^+=15V$, $T_a=25\text{ }^\circ\text{C}$			40	60	mA
Input offset voltage					7	mV
Input offset voltage drift	$R_s=0\Omega$			7		$\mu V/^\circ C$
Input offset current	$I_{IN(+)} - I_{IN(-)}$				100	on
Input offset current drift	$R_s=0\Omega$			10		$pA/^\circ C$
Input bias current	$I_{IN(+)}$ or $I_{IN(-)}$			40	300	nA
Input Common Mode Voltage Range	$V^+=30V$		0		V^+-2	V
Large signal voltage gain	$V^+=15V$, ($V_o = 1 \sim 11V$),		25			V/mV
Output voltage swing	V_{OH}	$V^+=30V$	$R_L=2k\Omega$	26		V
			$R_L=10k\Omega$	27	28	V
	V_{OL}	$V^+=5V$, $R_L=10k\Omega$		5	20	mV
Output current	source current	$V_{IN(+)} = 1V$, $V_{IN(-)} = 0V$, $V^+ = 15V$, $V_o = 2V$	10	20		mA
	current sink	$V_{IN(-)} = 1V$, $V_{IN(+)} = 0V$, $V^+ = 15V$, $V_o = 2V$	5	8		mA

typical application

Non-inverting DC gain
(0V input = 0V output)

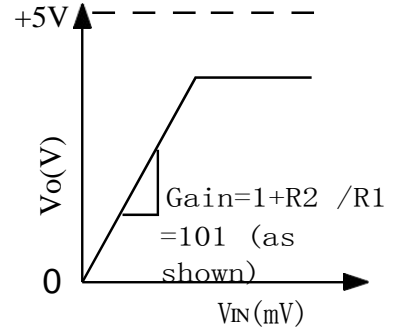
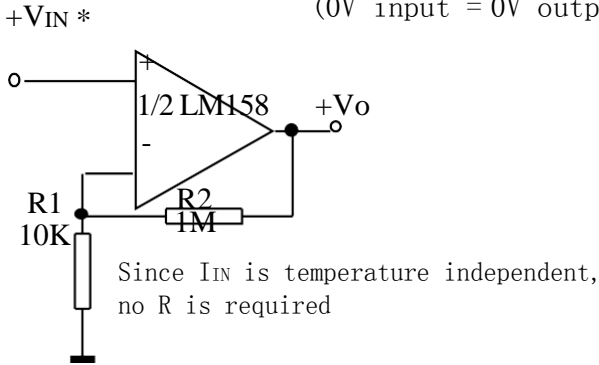

DC Summing Amplifier
(VIN'S ≥ 0V, and Vo ≥ 0V)

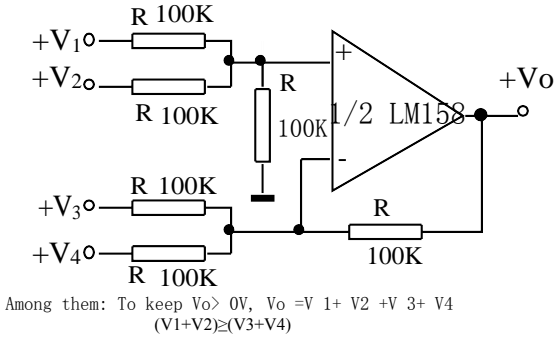

power amplifier

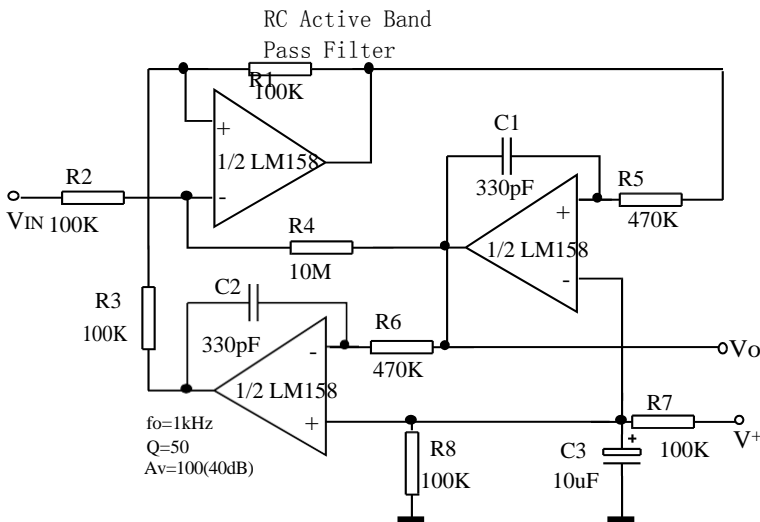
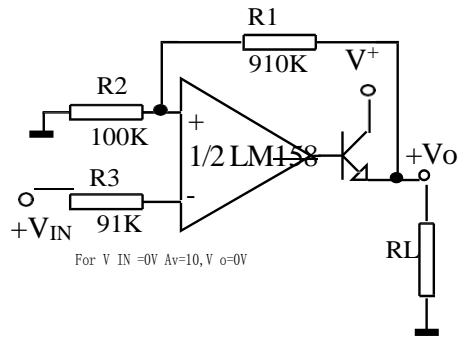

Fixed current source

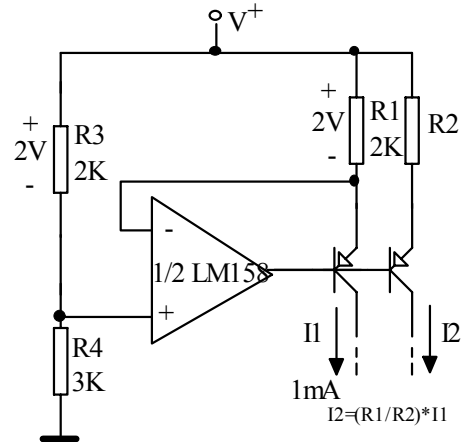

Typical characteristic curve

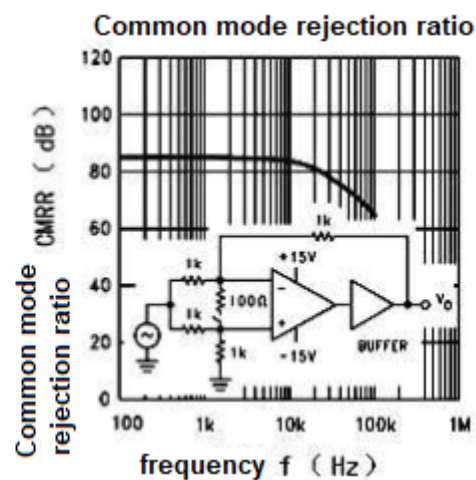
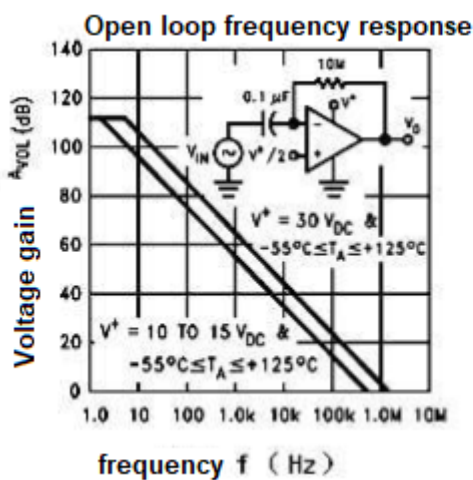
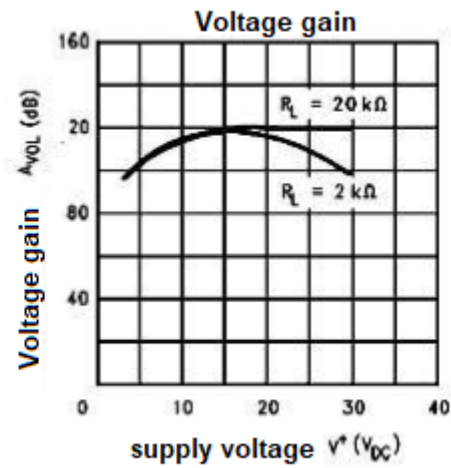
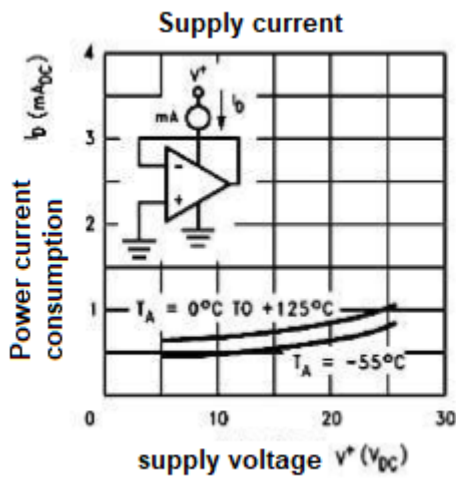
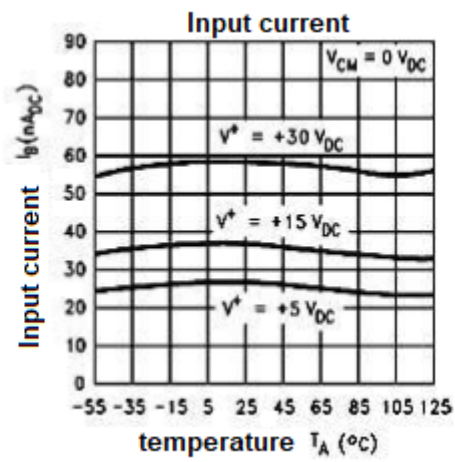
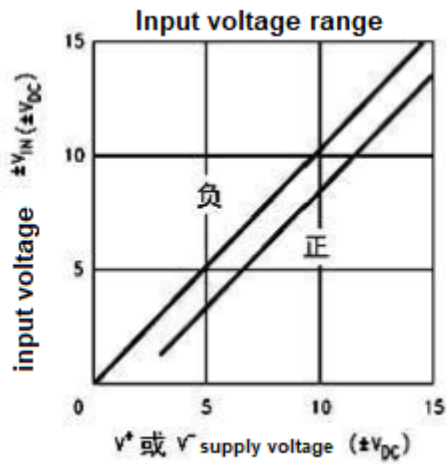

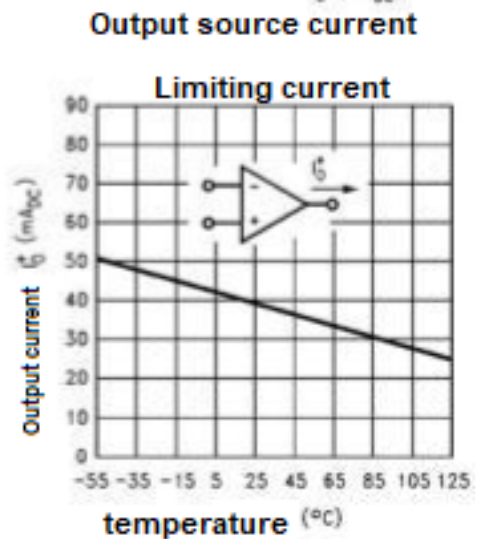
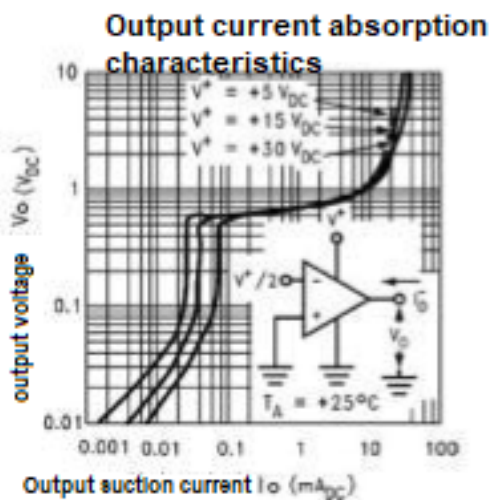
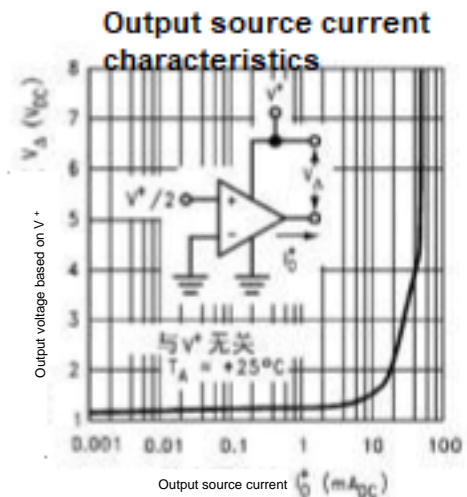
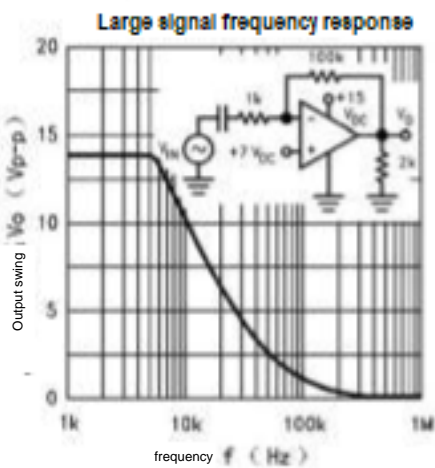
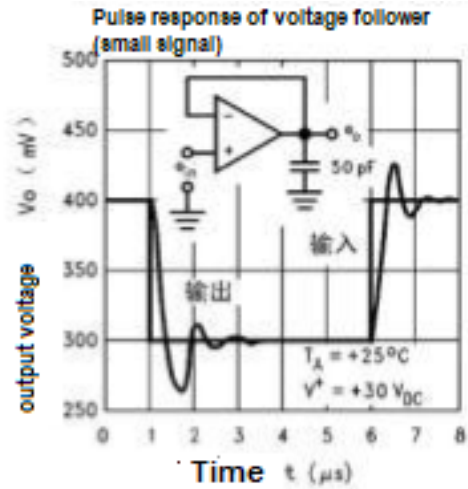
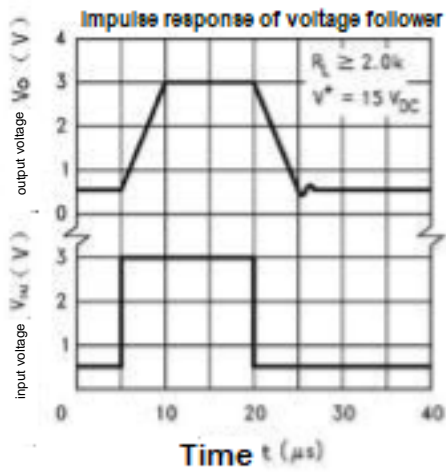



SOP 8

Looking for pricing, stock, or lifecycle information?

Click below to explore more details on WIN SOURCE:

-  [View LM158DR on WIN SOURCE](#)
-  [NXP / Nexperia Information](#)

Optimize Your Supply Chain with WIN SOURCE Solutions

-  Global Sourcing Solution
-  Obsolete Management
-  Cost Control Management
-  Shortage Management
-  Alternative Solution
-  Excess Inventory Management