



**THE DATASHEET OF
TPS7B7701QPWPRQ1**



TPS7B770x-Q1, Automotive, Single- and Dual-Channel Antenna LDO With Current Sense

1 Features

- Qualified for Automotive Applications
- AEC-Q100 Qualified With the Following Results:
 - Device Temperature Grade 1: -40°C to 125°C Ambient Operating Temperature Range
 - Device HBM ESD Classification 2
 - Device CDM ESD Classification C4B
- Single and Dual-Channel LDO With Current Sense and Adjustable Current-Limit
- 4.5-V to 40-V Wide Input Voltage Range, 45-V Load Dump
- Power Switch Mode When Tying FB to GND
- 1.5-V to 20-V Adjustable Output Voltage
- Up to 300-mA Output Current per Channel
- Adjustable Current-Limit With External Resistor
- High Accuracy Current-Sense to Detect Antenna Open Condition at Low Current Without Further Calibration
- High Power-Supply Rejection Ratio: Typical 73 dB at 100 Hz
- Integrated Reverse-Polarity Protection, Down to -40 V and No Need for External Diode
- 500-mV Max Dropout Voltage at 100-mA Load
- Stable With Output Capacitor in 2.2- μF to 100- μF Range (ESR 1 m Ω to 5 Ω)
- Integrated Protection and Diagnostics
 - Thermal Shutdown
 - Undervoltage Lockout (UVLO)
 - Short-Circuit Protection
 - Reverse Battery Polarity Protection
 - Reverse-Current Protection
 - Output Short-to-Battery Protection
 - Output Inductive Load Clamp
 - Multiplexing Current Sense Between Channels and Devices
 - Ability to Distinguish All Faults With Current Sense
- 16-Pin HTSSOP PowerPAD™ Package

2 Applications

- Infotainment Active-Antenna Power Supplies
- Surround-View Camera Power Supplies
- High-Side Power Switch For Small-Current Applications

3 Description

The TPS7B770x-Q1 family of devices feature a single and dual, high-voltage low-dropout regulator (LDO) with current sensing, designed to operate with a wide input-voltage range from 4.5 V to 40 V (45-V load dump protection). These devices provide power to the low-noise amplifiers of the active antenna through a coax cable with 300 mA per channel current. Each channel also provides an adjustable output voltage from 1.5 V to 20 V.

These devices provide diagnostics through the current sense and error pins. To monitor the load current, a high-side current-sense circuitry provides a proportional analog output to the sensed load current. The accurate current sense allows detection of open, normal, and short-circuit conditions without the need for further calibration. Current sense can be multiplexed between channels and devices to save analog-to-digital converter (ADC) resources. Each channel also implements adjustable current limit with an external resistor.

An integrated reverse polarity diode eliminates the need for an external diode. These devices feature standard thermal shutdown, short-to-battery protection on the output, and reverse current protection. Each channel has internal inductive clamp protection on the output during inductive switch off.

These devices operate over a -40°C to $+125^{\circ}\text{C}$ ambient temperature range.

Device Information⁽¹⁾

PART NUMBER	PACKAGE	CHANNEL
TPS7B7701-Q1	HTSSOP (16)	Single
TPS7B7702-Q1	HTSSOP (16)	Dual

(1) For all available packages, see the package option addendum at the end of the data sheet.

Application Diagram

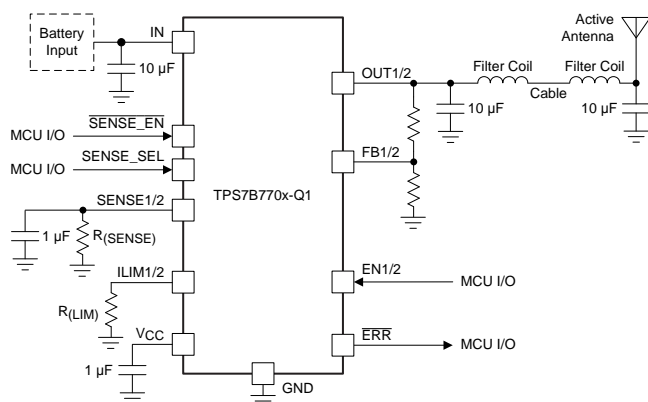

Table of Contents

1 Features	1	7.4 Device Functional Modes.....	14
2 Applications	1	8 Application and Implementation	15
3 Description	1	8.1 Application Information.....	15
4 Revision History	2	8.2 Typical Application	15
5 Pin Configuration and Functions	3	9 Power Supply Recommendations	18
6 Specifications	4	10 Layout	18
6.1 Absolute Maximum Ratings	4	10.1 Layout Guidelines	18
6.2 ESD Ratings.....	4	10.2 Layout Example	19
6.3 Recommended Operating Conditions.....	4	11 Device and Documentation Support	20
6.4 Thermal Information	5	11.1 Documentation Support	20
6.5 Electrical Characteristics.....	5	11.2 Related Links	20
6.6 Switching Characteristics	6	11.3 Receiving Notification of Documentation Updates	20
6.7 Typical Characteristics	7	11.4 Community Resources.....	20
7 Detailed Description	10	11.5 Trademarks	20
7.1 Overview	10	11.6 Electrostatic Discharge Caution.....	20
7.2 Functional Block Diagram	10	11.7 Glossary	20
7.3 Feature Description.....	11	12 Mechanical, Packaging, and Orderable Information	20

4 Revision History

NOTE: Page numbers for previous revisions may differ from page numbers in the current version.

Changes from Revision B (November 2015) to Revision C	Page
• Changed NC pin description in <i>Pin Functions</i> table to clarify which pins are internally connected	3
• Added row to <i>Recommended Operating Conditions</i> for OUT1, OUT2, and OUT regarding switched-mode operation	4
• Changed <i>Current-Limit Resistor Selection</i> section for clarity	17

Changes from Revision A (May 2015) to Revision B	Page
• Deleted the min and max limits of –4% and 4% from the current-limit threshold voltage parameter in the <i>Electrical Characteristics</i> table	6
• Added to the current-limit accuracy table note for the programmable current-limit accuracy parameter in the <i>Electrical Characteristics</i> table	6
• Added graphs for the TPS7B7701-Q1 device in the <i>Typical Characteristics</i> section	7
• Deleted the channel 2 PSRR graph in the <i>Typical Characteristics</i> section	7
• Added additional test conditions for the 9- to 16-V <i>Line Transient</i> and <i>Power Up</i> graphs in the <i>Typical Characteristics</i> section	9
• Added additional test conditions of the <i>Power Up</i> graphs in the <i>Application Curves</i> section	18

Changes from Original (January 2015) to Revision A	Page
• Released full version of data sheet	1

5 Pin Configuration and Functions

Single-Channel TPS7B7701-Q1 PWP Package
16-Pin HTSSOP With PowerPAD
Top View

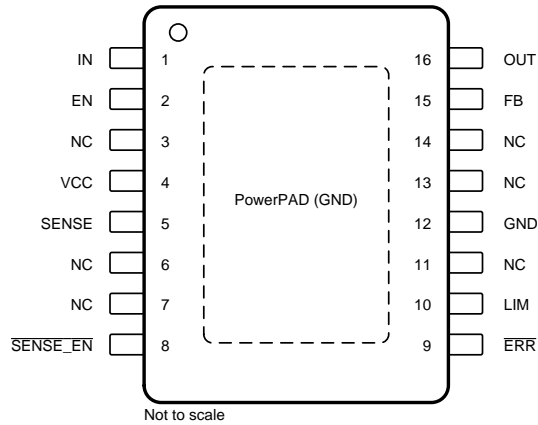

Dual-Channel TPS7B7702-Q1 PWP Package
16-Pin HTSSOP With PowerPAD
Top View

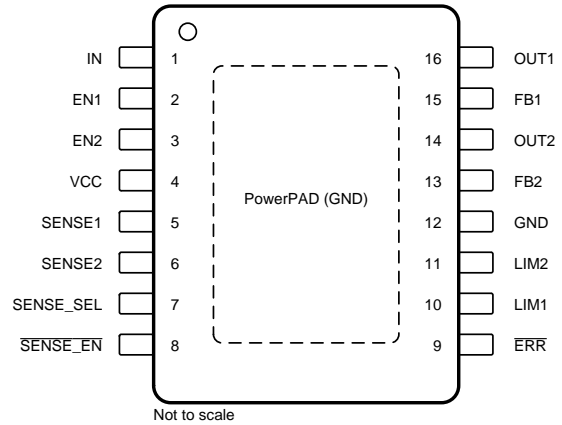

Pin Functions

NAME	PIN		TYPE	DESCRIPTION
	SINGLE-CHANNEL	DUAL-CHANNEL		
EN	2	—	Input	Active-high enable input for the OUT pin with internal pulldown.
EN1	—	2	Input	Active-high enable input for the OUT1 pin with internal pulldown.
EN2	—	3	Input	Active-high enable input for the OUT2 pin with internal pulldown.
ERR	9	9	Output	This pin is an open-drain fault indicator for general faults.
FB	15	—	Input	Feedback input for setting OUT voltage. Connect FB to GND for current-limited switch operation.
FB1	—	15	Input	Feedback input for setting OUT1 voltage. Connect FB1 to GND for current-limited switch operation.
FB2	—	13	Input	Feedback input for setting OUT2 voltage. Connect FB2 to GND for current-limited switch operation.
GND	12	12	Ground	Ground reference
IN	1	1	Power	Input power-supply voltage
LIM	10	—	Output	Programmable current-limit pin. Connect a resistor to GND to set the current limitation level. This pin does not need an external capacitor. To set to internal current limit, short this pin to GND.
LIM1	—	10	Output	Programmable current-limit pin for channel 1. Connect a resistor to GND to set the current limitation level for channel 1. This pin does not need an external capacitor. To set to internal current limit, short this pin to GND.
LIM2	—	11	Output	Programmable current-limit pin for channel 2. Connect a resistor to GND to set the current limitation level for channel 2. This pin does not need an external capacitor. To set to internal current limit, short this pin to GND.
NC	3, 13, 14	—	—	Not connected. Connect the NC pins to ground or leave floating.
	6, 7, 11	—	—	Internally connected. These pins must either be floated or connected to GND.
OUT	16	—	Power	Output voltage
OUT1	—	16	Power	Output voltage 1
OUT2	—	14	Power	Output voltage 2
SENSE	5	—	Output	Output of current sense for sensing. To set the SENSE output voltage level, connect a resistor between this pin and GND. In addition, connect a 1- μ F capacitor from this pin to GND for frequency compensation of the current-sense loop. Short this pin to GND if not used.
SENSE1	—	5	Output	Output of current sense for sensing. SENSE1 current is proportional to the current flow through OUT1 and SENSE 2 current is proportional to OUT2 current when SENSE_SEL and SENSE_EN are low. To set the SENSEx output voltage level, connect a resistor between this pin and GND. In addition, connect a 1- μ F capacitor from the SENSEx pin to GND for frequency compensation of the current-sense loop. Short the SENSEx pin to GND if not used.
SENSE2	—	6	Output	
SENSE_EN	8	8	Input	This pin is the enable and disable of the current-sense pin for multiplexing, active-low enable.
SENSE_SEL	—	7	Input	This pin selects the current sense between channel 1 and channel 2. See Table 2 for details.
V _{CC}	4	4	Output	Internal 4.5-V regulator. Connect 1- μ F ceramic capacitor between V _{CC} and GND for frequency compensation.

6 Specifications

6.1 Absolute Maximum Ratings

 over operating free-air temperature range (unless otherwise noted)⁽¹⁾

		MIN	MAX	UNIT
Input voltage	Unregulated input, IN	-40	45	V
	EN, EN1, and EN2	-0.3	45	V
Regulated output ⁽²⁾	V _{CC} ⁽³⁾⁽⁴⁾	-0.3	6	V
	OUT1 and OUT2	-0.3	45	V
Low-voltage pins	SENSE, SENSE1, and SENSE2 ⁽³⁾⁽⁴⁾	-0.3	V _{CC} + 0.3	V
	LIM, LIM1, LIM2, $\overline{\text{SENSE_EN}}$, SENSE_SEL, $\overline{\text{ERR}}$, FB, FB1, and FB2 ⁽³⁾⁽⁴⁾	-0.3	7	V
Operating junction temperature, T _J		-40	150	°C
Operating ambient temperature, T _A		-40	125	°C
Storage Temperature, T _{stg}		-65	150	°C

- (1) Stresses beyond those listed under *Absolute Maximum Ratings* may cause permanent damage to the device. These are stress ratings only, which do not imply functional operation of the device at these or any other conditions beyond those indicated under *Recommended Operating Conditions*. Exposure to absolute-maximum-rated conditions for extended periods may affect device reliability.
- (2) There is an internal diode connects between the OUT and GND pins with 300-mA DC current capability for inductive clamp protection.
- (3) All voltage values are with respect to GND.
- (4) Absolute maximum voltage.

6.2 ESD Ratings

		VALUE	UNIT	
V _(ESD) Electrostatic discharge	Human body model (HBM), per AEC Q100-002 ⁽¹⁾	±2000	V	
	Charged device model (CDM), per AEC Q100-011	Corner pins (1, 8, 9, and 16)		±750
		Other pins		±500

- (1) AEC Q100-002 indicates HBM stressing is done in accordance with the ANSI/ESDA/JEDEC JS-001 specification.

6.3 Recommended Operating Conditions

over operating free-air temperature range (unless otherwise noted)

		MIN	MAX	UNIT
V _I	Unregulated input	4.5	40	V
	EN, EN1, and EN2	0	40	V
Low-voltage pins	SENSE, SENSE1, SENSE2, $\overline{\text{SENSE_EN}}$, SEN_SEL, $\overline{\text{ERR}}$, FB, FB1, FB2, LIM, LIM1, LIM2, and V _{CC}	0	5.3	V
OUT1, OUT2, and OUT	Normal-mode operation	1.5	20	V
	Switched-mode operation	1.5	35	
C _O	Output capacitor stability range	2.2	100	μF
C _{O(ESR)}	Output capacitor ESR stability range	0.001	5	Ω
T _J	Junction temperature	-40	150	°C
T _A	Ambient temperature	-40	125	°C

6.4 Thermal Information

THERMAL METRIC ⁽¹⁾		TPS7B7701-Q1	TPS7B7702-Q1	UNIT
		PWP (HTSSOP)	PWP (HTSSOP)	
		16 PINS	16 PINS	
R _{θJA}	Junction-to-ambient thermal resistance ⁽²⁾	45.9	40.3	°C/W
R _{θJC(top)}	Junction-to-case (top) thermal resistance	29.2	27.7	°C/W
R _{θJB}	Junction-to-board thermal resistance	24.7	22.3	°C/W
Ψ _{JT}	Junction-to-top characterization parameter	1.3	0.8	°C/W
Ψ _{JB}	Junction-to-board characterization parameter	24.5	22	°C/W
R _{θJC(bot)}	Junction-to-case (bottom) thermal resistance	3.7	2.7	°C/W

- (1) For more information about traditional and new thermal metrics, see the [Semiconductor and IC Package Thermal Metrics](#) application report.
- (2) The thermal data is based on JEDEC standard high K profile – JESD 51-7. The copper pad is soldered to the thermal land pattern. Also correct attachment procedure must be incorporated

6.5 Electrical Characteristics

at V_I = 14 V and T_J = –40°C to +150°C (unless otherwise stated)

PARAMETER		TEST CONDITIONS	MIN	TYP	MAX	UNIT
SUPPLY VOLTAGE AND CURRENT (IN)						
V _I	Input voltage		4.5		40	V
I _Q	Quiescent current	TPS7B7701-Q1: V _I = 4.5 to 40 V, V _(EN) ≥ 2 V, I _(OUT) = 0.1 mA TPS7B7702-Q1: V _I = 4.5 to 40 V, V _(EN1) and V _(EN2) ≥ 2 V, I _(OUT1) and I _(OUT2) = 0.1 mA		0.6	1	mA
I _(shutdown)	Shutdown current	TPS7B7701-Q1: EN = GND TPS7B7702-Q1: EN1 = EN2 = GND			5	μA
I _{nom}	Operating current	TPS7B7701-Q1: V _(EN) ≥ 2 V, I _(OUT) ≤ 300 mA, GND current TPS7B7702-Q1: V _(EN1) and V _(EN2) ≥ 2 V, I _(OUT1) and I _(OUT2) ≤ 300 mA, GND current			4.5	mA
V _(BG)	Bandgap	Reference voltage for FB	–2%	1.233	2%	V
V _(UVLO)	Undervoltage lockout falling	Ramp IN down until the output turns off			4	V
V _{hys}	Hysteresis			0.4		V
INPUT CONTROL PINS (EN, EN1, EN2, SENSE_EN, AND SENSE_SEL)						
V _{IL}	Logic input low level	For EN, EN1, EN2, SENSE_EN, and SENSE_SEL	0		0.7	V
V _{IH}	Logic input high level	For EN, EN1, EN2, SENSE_EN, and SENSE_SEL	2			V
I _{I(SENSE_EN)}	SENSE_EN input current	V _(SENSE_EN) = 5 V, V _(ENx) ≥ 2 V			10	μA
I _{I(SENSE_SEL)}	SENSE_SEL input current	V _(SENSE_EN) = 5 V, V _(ENx) ≥ 2 V			10	μA
I _{I(EN)}	Enable input current	V _(ENx) ≤ 40 V			10	μA
REGULATED OUTPUT (OUT, OUT1, AND OUT2)						
V _O	Regulated output	40 V ≥ V _I ≥ V _O + 1.5 V and V _I ≥ 4.5 V, I _O = 1 to 300 mA ⁽¹⁾	–2%		2%	
ΔV _{O(ΔVI)}	Line regulation	V _I = V _O + 1.5 V to 40 V and V _I ≥ 6 V, I _O = 10 mA, voltage variation on FB pin			10	mV
ΔV _{O(ΔIO)}	Load regulation	I _O = 1 mA to 200 mA, voltage variation on FB pin			20	mV
V _(DROPOUT)	Dropout voltage	Measured between IN and OUTx, I _O = 100 mA			500	mV
I _O	Output current	V _O in regulation	0		300	mA
PSRR	Power supply ripple rejection ⁽²⁾	I _O = 100 mA, C _O = 2.2 μF, f = 100 Hz		73		dB
CURRENT SENSE AND CURRENT-LIMIT						
I _O /I _{SENSE}	OUTx to SENSEx current ratio (I _O / I _{SENSEx})	V _I = 4.5 V to 40 V, 5 mA ≤ I _O ≤ 300 mA		198		

- (1) External feedback resistor is not considered.
- (2) Design information; specified by design, not production tested.

Electrical Characteristics (continued)

 at $V_I = 14\text{ V}$ and $T_J = -40^\circ\text{C}$ to $+150^\circ\text{C}$ (unless otherwise stated)

PARAMETER	TEST CONDITIONS	MIN	TYP	MAX	UNIT	
OUTx to SENSEx current ratio accuracy	$I_O = 100$ to 300 mA	-3%		3%		
	$I_O = 50$ to 100 mA	-5%		5%		
	$I_O = 10$ to 50 mA	-10%		10%		
	$I_O = 5$ to 10 mA	-20%		20%		
I_O/I_{LIM}	OUTx to LIMx current ratio (I_O / I_{LIM})	$V_I = 4.5\text{ V}$ to 40 V , $50\text{ mA} \leq I_{(LIMx)} \leq 300\text{ mA}$		198		
$I_{(LIMx)}$	Programmable current-limit accuracy ⁽³⁾	$V_I = 4.5\text{ V}$ to 40 V , $50\text{ mA} \leq I_{(LIMx)} \leq 300\text{ mA}$		-8%	8%	
$I_{L(LIMx)}$	Internal current-limit	LIMx shorted to GND		340	550	
I_{lkg}	SENSE, SENSE1, SENSE2, LIM, LIM1, and LIM2 leakage current	ENx = GND, $T_A = 25^\circ\text{C}$			2	
$V_{(LIMx_th)}$	Current-limit threshold voltage	Voltage on the LIM, LIM1, and LIM2 pins when output current is limited		1.233	V	
$V_{(SENSEx_stb)}$	Current-sense short-to-battery fault voltage	When short-to-battery or reverse current conditions are detected		3.05	3.2	3.3
$V_{(SENSEx_tsd)}$	Current-sense thermal shutdown fault voltage	When thermal shutdown is detected		2.7	2.85	3
$V_{(SENSEx_cl)}$	Current-sense current-limit fault voltage	When current-limit conditions are detected		2.4	2.55	2.65
$I_{(SENSEx_H)}$	Current-sense fault condition current	When short-to-battery, reverse current, thermal shutdown, or current-limit conditions are detected		3.3		mA
FAULT DETECTION						
$V_{(stb_th)}$	Short-to-battery threshold	$V_{(OUTx)} - V_I$, checked during turnon sequence		-500	-55	110
$I_{(REV)}$	Reverse current detection level	Power FET on (SW or LDO mode)		-100	-40	-1
T_{SD}	Thermal shutdown	Junction temperature			175	$^\circ\text{C}$
$T_{SD(hys)}$	Thermal shutdown hysteresis				15	$^\circ\text{C}$
INTERFACE CIRCUITRY						
V_{OL}	$\overline{\text{ERR}}$ output low	$I_{(SINK)} = 5\text{ mA}$			0.4	V
I_{lkg}	$\overline{\text{ERR}}$ open-drain leakage current	$\overline{\text{ERR}}$ high impedance, 5-V external voltage is applied at $\overline{\text{ERR}}$			1	μA
$R_{(OUTx_off)}$	OUT pulldown resistor ⁽²⁾	ENx = GND			50	k Ω
$I_{R(lkg)}$	Reverse leakage current	$-40\text{ V} < V_I < 0\text{ V}$, reverse current to IN			0.6	mA
V_{CC}	Internal voltage regulator	$V_I = 5.5$ to 40 V , $I_{CC} = 0\text{ mA}$		4.25	4.5	4.75
$I_{CC(lim)}$	Internal voltage-regulator current-limit			15		70

(3) The current-limit accuracy is maintained when the current limit is set between 50 mA and 300 mA, and it includes the deviation of the current-limit threshold voltage $V_{(LIMx_th)}$.

6.6 Switching Characteristics

PARAMETER	TEST CONDITIONS	MIN	TYP	MAX	UNIT	
CURRENT SENSE AND CURRENT-LIMIT						
$t_{d(SENSE_SEL_r)}$	Current-sense delay time from the rising edge of SENSE_SEL ⁽¹⁾	$V_{(ENx)} \geq 2\text{ V}$, $\overline{\text{SENSE_EN}} = \text{GND}$, SENSE_SEL rise from 0 to 5 V			10	μs
$t_{d(SENSE_SEL_f)}$	Current-sense delay time from the falling edge of SENSE_SEL ⁽¹⁾	$V_{(ENx)} \geq 2\text{ V}$, $\overline{\text{SENSE_EN}} = \text{GND}$, SENSE_SEL fall from 5 to 0 V			10	μs
$t_{d(SENSE_EN_r)}$	Current-sense delay time from rising edge of SENSE_EN ⁽¹⁾	$V_{(ENx)} \geq 2\text{ V}$, $\overline{\text{SENSE_EN}}$ rise from 0 to 5 V			10	μs
$t_{d(SENSE_EN_f)}$	Current-sense delay time from falling edge of SENSE_EN ⁽¹⁾	$V_{(ENx)} \geq 2\text{ V}$, $\overline{\text{SENSE_EN}}$ fall from 5 to 0 V			10	μs
FAULT DETECTION						
$t_{(PD_RC)}$	Reverse current (Short-to-BAT) shutdown deglitch time	Delay to shut down the switch or LDO after a drop over r_{on} becomes negative, $I_{(OUTx)} = -200\text{ mA}$ (typical), $T_A = 25^\circ\text{C}$			5	20
$t_{(BLK_RC)}$	Reverse current blanking time	Blanking time for reverse-current detection after power up, the rising edge of the ENx pin, or the current limiting event is over			16	ms

(1) Design information; specified by design; not production tested.

6.7 Typical Characteristics

at $V_I = 14\text{ V}$ (unless otherwise specified)

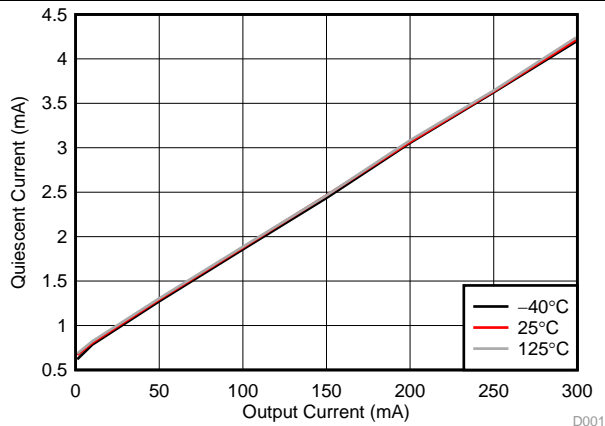

Figure 1. Quiescent Current vs Output Current (TPS7B7702-Q1)

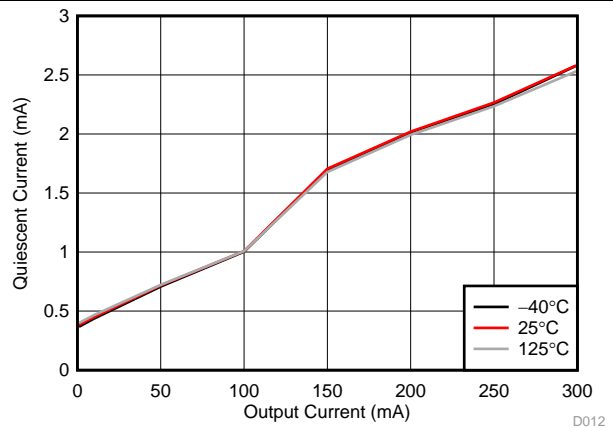

Figure 2. Quiescent Current vs Output Current (TPS7B7701-Q1)

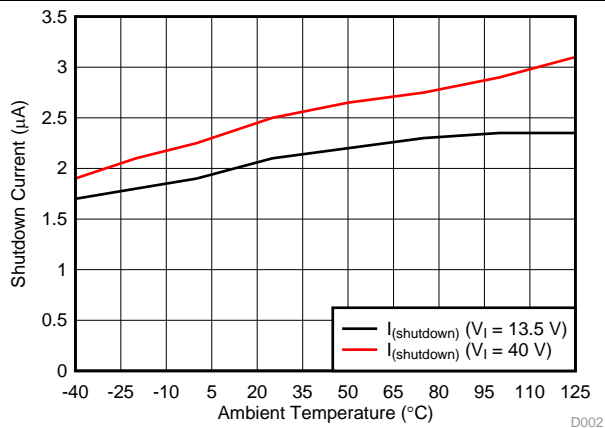

Figure 3. Shutdown Current vs Ambient Temperature (TPS7B7702-Q1)

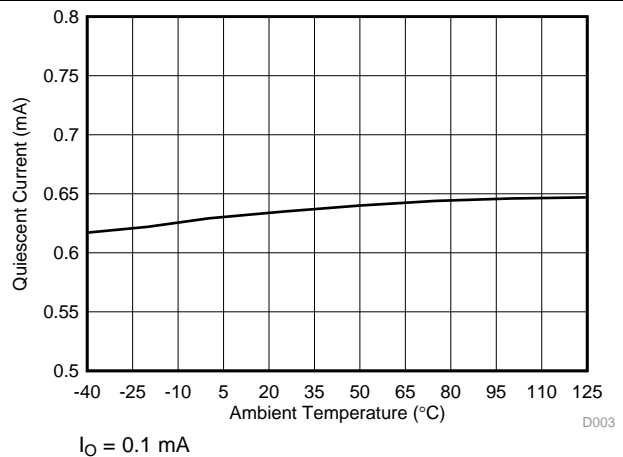

Figure 4. Quiescent Current vs Ambient Temperature (TPS7B7702-Q1)

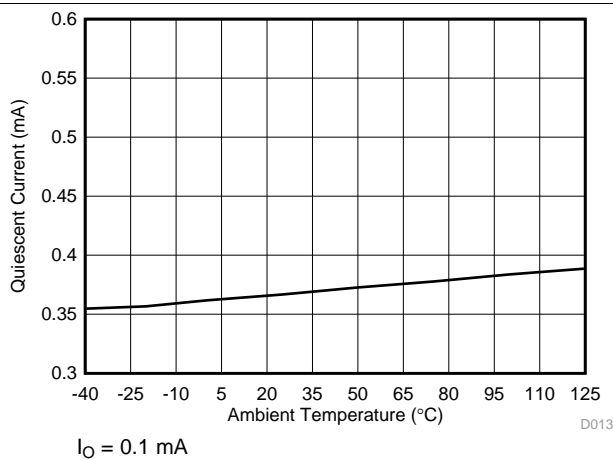

Figure 5. Quiescent Current vs Ambient Temperature (TPS7B7701-Q1)

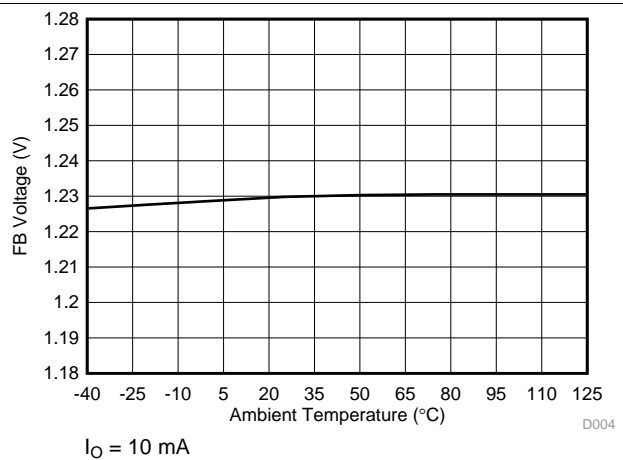

Figure 6. FB Voltage vs Ambient Temperature (TPS7B7701-Q1)

Typical Characteristics (continued)

at $V_I = 14\text{ V}$ (unless otherwise specified)

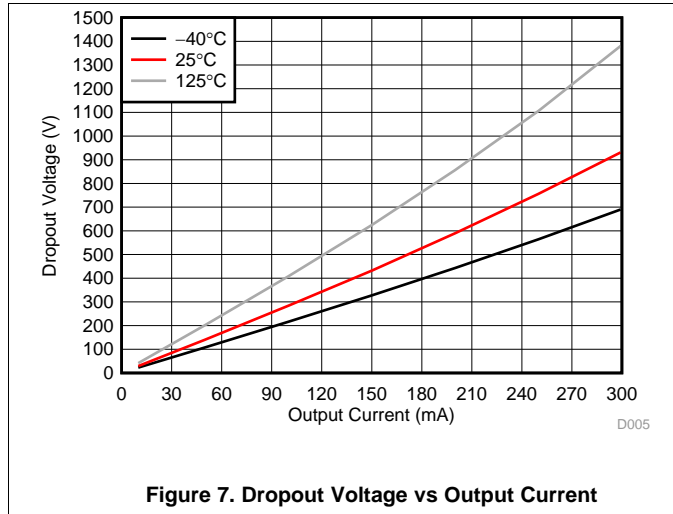

Figure 7. Dropout Voltage vs Output Current

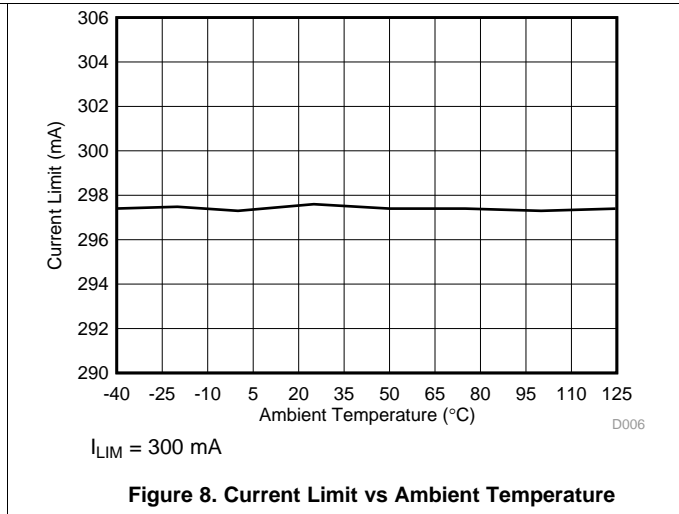

Figure 8. Current Limit vs Ambient Temperature

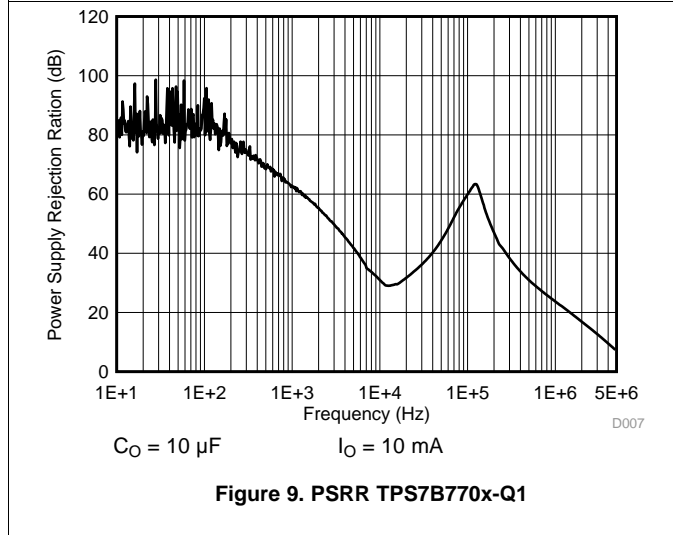

Figure 9. PSRR TPS7B770x-Q1

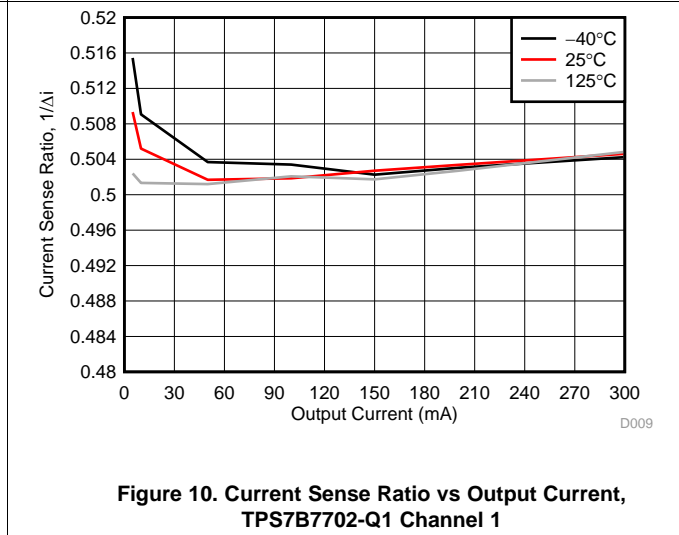

Figure 10. Current Sense Ratio vs Output Current, TPS7B7702-Q1 Channel 1

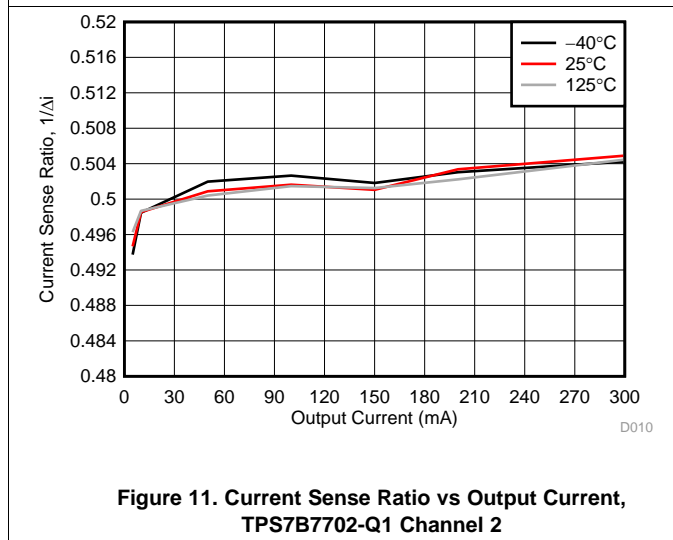

Figure 11. Current Sense Ratio vs Output Current, TPS7B7702-Q1 Channel 2

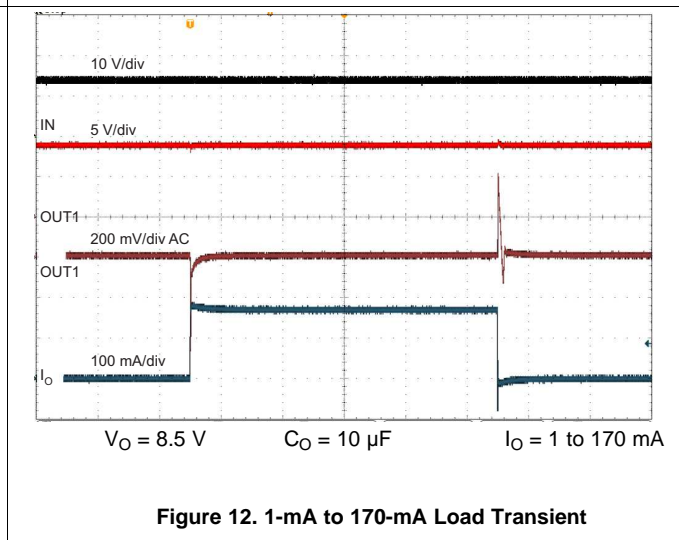

Figure 12. 1-mA to 170-mA Load Transient

Typical Characteristics (continued)

at $V_I = 14\text{ V}$ (unless otherwise specified)

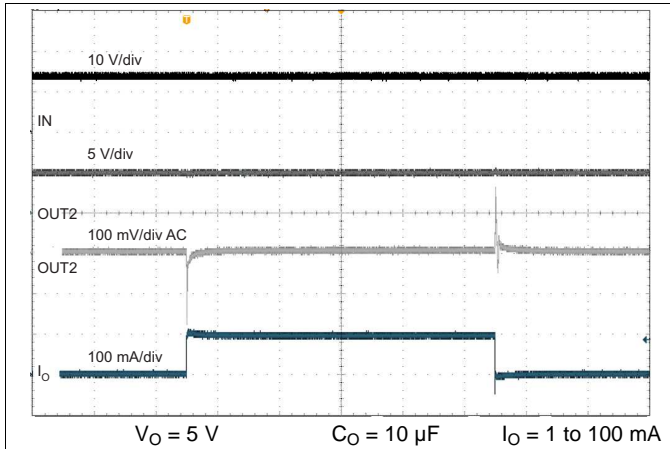

Figure 13. 1-mA to 100-mA Load Transient

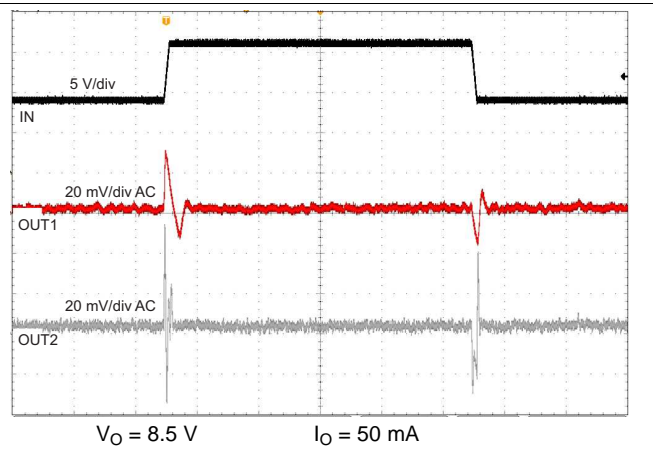

Figure 14. 9-V to 16-V Line Transient (1 V/μs)

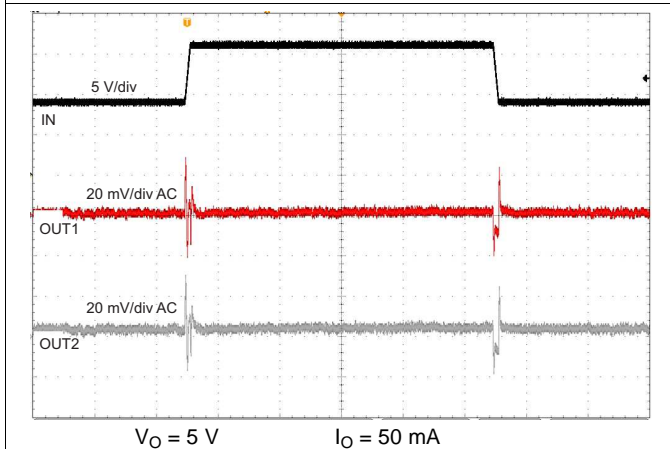

Figure 15. 9-V to 16-V Line Transient (1 V/μs)

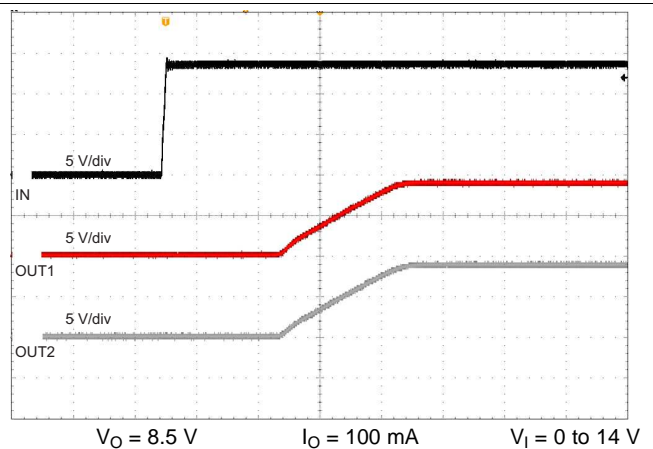

Figure 16. Power Up (1 V/μs)

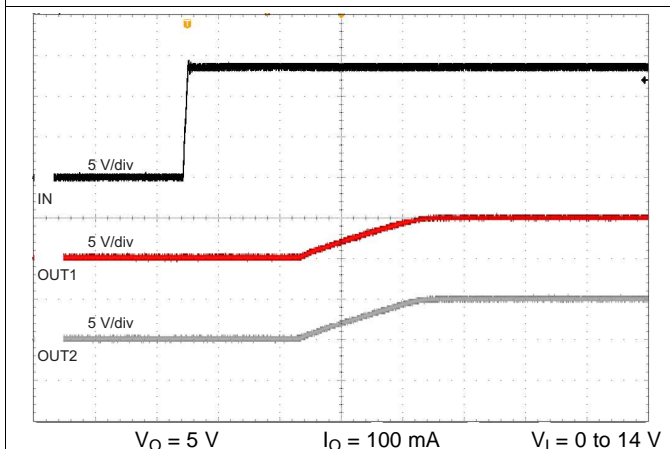

Figure 17. Power Up (1 V/μs)

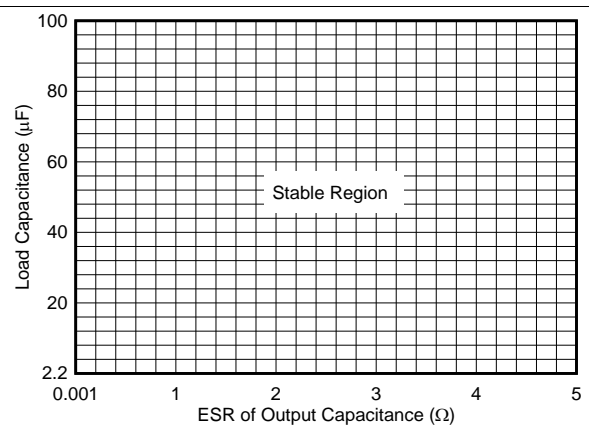

Figure 18. Load Capacitance vs ESR of Output Capacitance

7 Detailed Description

7.1 Overview

The TPS7B770x-Q1 family of devices feature a single- or dual-channel, high voltage LDO with a current-sense function. These devices operate with a wide input-voltage range of 4.5 V to 40 V (45-V load dump protection). These devices also offers protection of antenna lines against electrostatic discharge (ESD) and from short-to-ground, short-to-battery, and thermal overstress. Device output voltage is adjustable from 1.5 V to 20 V through an external resistor divider. Alternatively, each channel can be configured as a switch.

These devices monitor the load. Accurate current sense allows for detection of open, normal, and short-circuit conditions without the need of further calibration. The current sense can also be multiplexed between channels and devices to save ADC resources. Each channel also provides an adjustable current limit with external resistor.

7.2 Functional Block Diagram

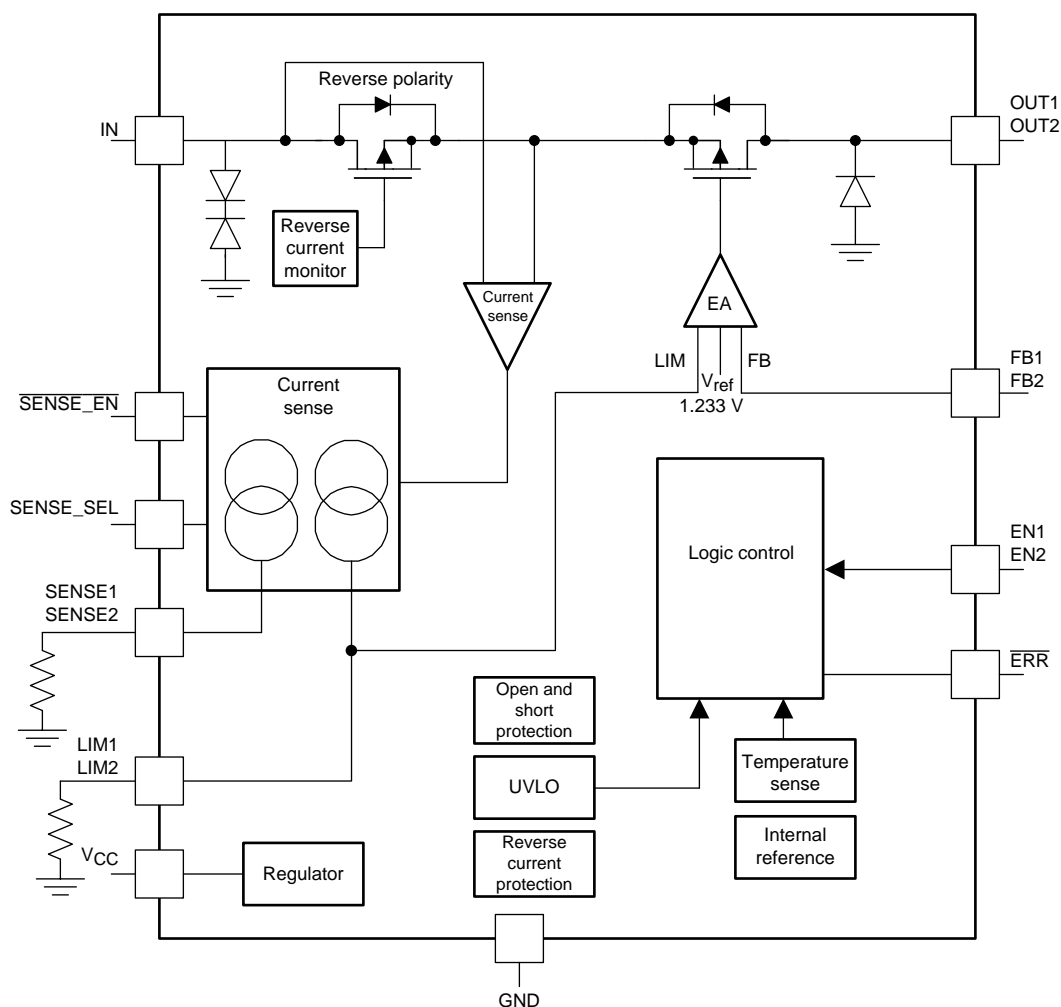

7.3 Feature Description

7.3.1 Fault Detection and Protection

The device includes both analog current sense and digital fault pins for full diagnostics of different fault conditions.

The current-sense voltage scale is selected based on the output-current range of interest. Figure 19 shows a recommended setting that allows for full diagnostics of each fault. Before the device goes into current-limit mode, the output current-sense voltage is linearly proportional to the actual load current. During a thermal-shutdown (TSD) and short-to-battery (STB) condition, the current-sense voltage is set to the fault voltage level that is specified in the [Electrical Characteristics](#) table.

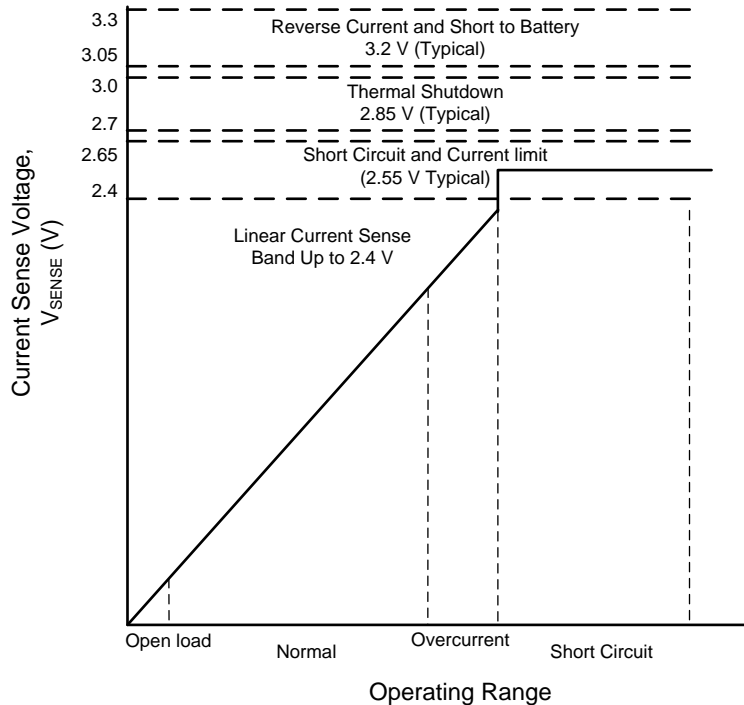

Figure 19. Functionality of the Current-Sense Output

7.3.2 Short-Circuit and Overcurrent Protection

The current limit on each channel is programmed by selecting the external resistor. The voltage on LIMx pin is compared with an internal voltage reference. When the threshold is exceeded, the current limit is triggered. The output of the current limited channel continues to remain on and the current is limited.

Under current-limit status, the \overline{ERR} pin asserts low and the SENSE voltage of the fault channel is internally pulled up to a voltage rail between 2.4 V and 2.65 V as shown in Figure 19. At this moment, the output voltage is not disabled. The microcontroller (MCU) should monitor the voltage at the SENSEx pin or \overline{ERR} pin to disable the faulted channel by pulling the \overline{ENx} pin low. If a current-limit condition exists for a long period of time, thermal shutdown can be triggered and shutdown the output.

7.3.3 Short-to-Battery and Reverse Current Detection

Shorting the OUT pin to the battery because of a fault in the system is possible. Each channel detects this failure by comparing the voltage at the OUT and IN pins before the switch turns on. Each time the LDO switch is enabled on the rising edge of the EN pin or during the exiting of the thermal shutdown, the short-to-battery detection occurs. At this moment, if the device detects the short-to-battery fault, the LDO switch is latched off, the \overline{ERR} pin is asserted low, and the fault-channel SENSE voltage is pulled up internally to a voltage rail between 3.05 V and 3.3 V. The device operates normally when the short-to-battery is removed and the EN pin is toggled.

Feature Description (continued)

During normal operation if a short-to-battery fault results in reverse current for more than 5 μ s (typical), the LDO switch is latched off and the $\overline{\text{ERR}}$ pin is asserted low. To remove the latched condition after a short-to-battery (reverse current) fault, the condition must first be removed and then the EN pin must be toggled.

Series inductance and the output capacitor can produce ringing during power up or recovery from current limit, resulting in an output voltage that temporarily exceeds the input voltage. The 16-ms (typical) reverse-current blanking can help filter this ringing.

For the dual-channel antenna LDO application, if both channels are enabled and one channel is shorted to ground after power up, the current drawn from the input capacitor can result in a temporary dip in the input voltage, which can trigger the reverse-current detection fault. To avoid this false trigger event, care must be taken when selecting the input capacitor; an increase of the input capacitor value is recommended.

7.3.4 Thermal Shutdown

The device incorporates a TSD circuit as a protection from overheating. For continuous normal operation, the junction temperature should not exceed the TSD trip point. If the junction temperature exceeds the TSD trip point, the output is turned off. When the junction temperature decreases by 15°C (typical) than the TSD trip point, the output is turned on again. The SENSE voltage is internally pulled up to a voltage rail between 2.7 V and 3 V during TSD status.

NOTE

The purpose of the design of the internal protection circuitry of the TPS7B770x-Q1 family of devices is to protect against overload conditions and is not intended as a replacement for proper heat-sinking. Continuously running the device into thermal shutdown degrades device reliability.

7.3.5 Integrated Reverse-Polarity Protection

The device integrates a reverse-connected PMOS to block the reverse current during reverse polarity at the input and output short-to-battery condition. A special ESD structure at the input is specified to withstand –40 V.

7.3.6 Integrated Inductive Clamp

During output turnoff, the cable inductance continues to source the current from the output of the device. The device integrates an inductive clamp to help dissipate the inductive energy stored in the cable. An internal diode is connected between OUT and GND pins with a DC-current capability of 300 mA for inductive clamp protection.

7.3.7 Undervoltage Lockout

The device includes an undervoltage lockout (UVLO) threshold that is internally fixed. The undervoltage lockout activates when the input voltage on the IN pin drops below $V_{(\text{UVLO})}$. The UVLO makes sure that the regulator is not latched into an unknown state during low input-supply voltage. If the input voltage has a negative transient that drops below the UVLO threshold and then recovers, the regulator shuts down and powers up with a normal power-up sequence when the input voltage is above the required levels.

Table 1. Fault Table

FAILURE MODE	$V_{(\text{SENSE})}$	$\overline{\text{ERR}}$	LDO SWITCH OUTPUT	LATCHED
Open load	$I_O \times R_{(\text{SENSE})}$ 198	HIGH	Enabled	No
Normal		HIGH	Enabled	No
Overcurrent		HIGH	Enabled	No
Short-circuit or current limit	2.4 to 2.65 V	LOW	Enabled	No
Thermal shutdown	2.7 to 3 V	LOW	Disabled	No
Output short-to-battery	3.05 to 3.3 V	LOW	Disabled	Yes
Reverse current	3.05 to 3.3 V	LOW	Disabled	Yes

7.3.8 Enable (EN, EN1, and EN2)

The TPS7B7702-Q1 device features two active-high enable inputs, EN1 and EN2. The EN1 pin controls output voltage 1, OUT1, and the EN2 pin controls output voltage 2, OUT2. The device consumes a maximum of shutdown current 5- μ A when the ENx pins are low. Both the EN1 and EN2 pins have a maximum internal pulldown of 10 μ A.

The TPS7B7701-Q1 device features one active-high enable input. The device consumes a maximum shutdown current of 5 μ A when the EN pin is low. The EN pin has a maximum internal pull down of 10 μ A.

7.3.9 Internal Voltage Regulator (V_{CC})

The device features an internal regulator that regulates the input voltage to 4.5 V to power all internal circuitry. Bypass a 1- μ F ceramic capacitor from the V_{CC} pin to the GND pin for frequency compensation. The V_{CC} pin can be used as a power supply for external circuitry with up to 15-mA current capability.

7.3.10 Current Sense Multiplexing

The two, independent current sense pins (one for each channel) provide flexibility in the system design. When the ADC resource is limited, the device allows the multiplexing of the current sense pins by only using one current sense pin and one ADC to monitor all the antenna outputs.

The SENSE_SEL pin (TPS7B7702-Q1 only) selects the channels to monitor the current. The $\overline{\text{SENSE_EN}}$ pin enables and disables the SENSE pin, allowing multiplexing between chips. Therefore, only one ADC and one resistor is needed for current-sense diagnostics of multiple outputs. When the SENSE1 pin is connected to an ADC, the current flow through both channels can be sensed by changing the electrical level at the SENSE_SEL pin.

Table 2 lists the selection logic for the current sense.

Table 2. $\overline{\text{SENSE_EN}}$ and SEN_SEL Logic Table

$\overline{\text{SENSE_EN}}$	SEN_SEL	SENSE1 Status	SENSE2 Status
LOW	LOW	CH1 current	CH2 current
LOW	HIGH	CH2 current	HIGH impedance
HIGH	—	HIGH impedance	HIGH impedance

Figure 20 shows the application of four antenna channels sharing one ADC resource.

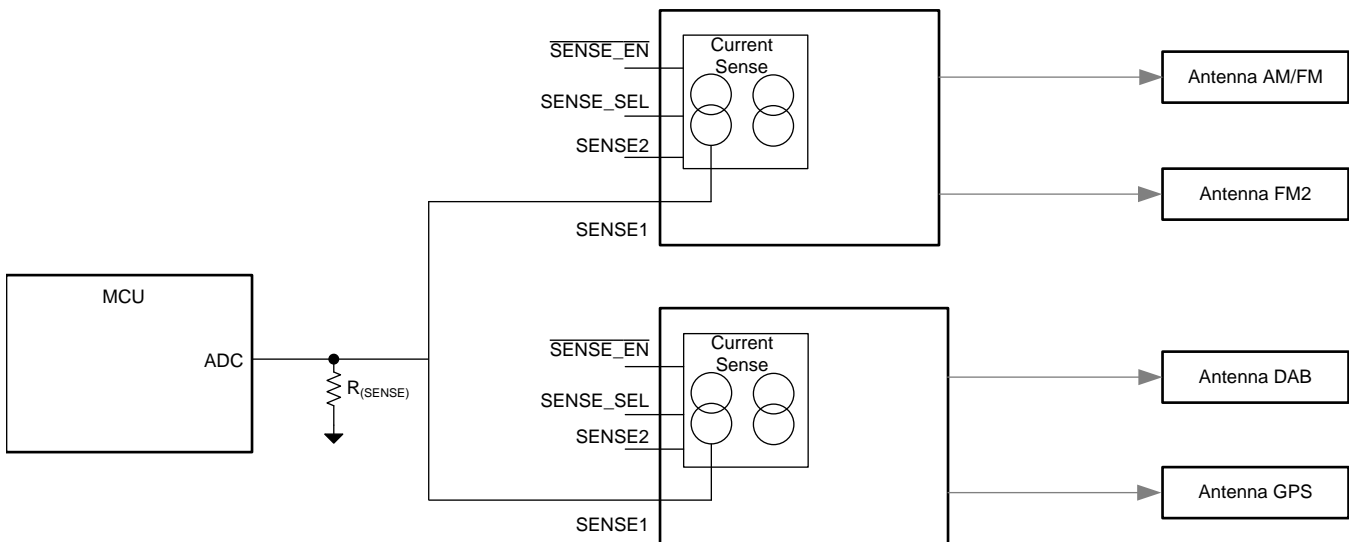

Figure 20. Current Multiplexing Application Block

7.3.11 Adjustable Output Voltage (FB, FB1, and FB2)

Using an external resistor divider selects an output voltage between 1.5 V and 20 V. Use [Table 2](#) to calculate the output voltage (V_O). The recommended value for both R1 and R2 is less than 100 k Ω .

$$V_O = \frac{V_{(FB)} \times (R1 + R2)}{R2}$$

where

- $V_{(FB)} = 1.233 \text{ V}$ (1)

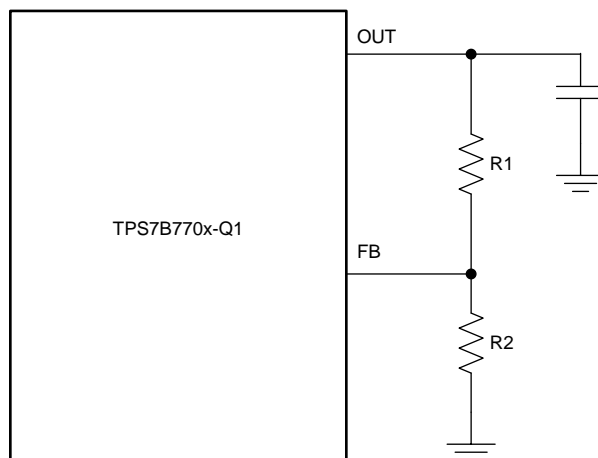

Figure 21. TPS7B770x-Q1 Output Voltage Setting Connection

The TPS7B770x-Q1 family of devices can also be used as a current-limited switch by connecting the FB pin to the GND pin.

7.4 Device Functional Modes

7.4.1 Operation With $IN < 4.5 \text{ V}$

The maximum UVLO voltage is 4 V and the device operates at an input voltage above 4.5V. The device can also operate at lower input voltage. No minimum UVLO voltage is specified. At an input voltage below the actual UVLO voltage, the device does not operate.

7.4.2 Operation With EN Control

The threshold of EN rising edge is 2 V (maximum). With the EN pin held above that voltage and the input voltage above 4.5 V, the device becomes active. The EN falling edge is 0.7 V (minimum). Holding the EN pin below that voltage disables the device which therefore reduces the quiescent current of the device.

8 Application and Implementation

NOTE

Information in the following applications sections is not part of the TI component specification, and TI does not warrant its accuracy or completeness. TI's customers are responsible for determining suitability of components for their purposes. Customers should validate and test their design implementation to confirm system functionality.

8.1 Application Information

The TPS7B770x-Q1 family of devices is a single- or dual-channel 300-mA LDO regulator with high, accurate current sense and a programmable current-limit function. Use the PSPICE transient model to evaluate the base function of the devices. Go to www.ti.com to download the PSPICE model and user's guide for the devices.

8.2 Typical Application

Figure 22 shows the typical application circuit for the TPS7B770x-Q1 family of devices. Different values of external components can be used depending on the end application. An application can require a larger output capacitor during fast load steps to prevent large drops on output voltage. TI recommends a low-ESR ceramic capacitor with a dielectric of type X5R or X7R.

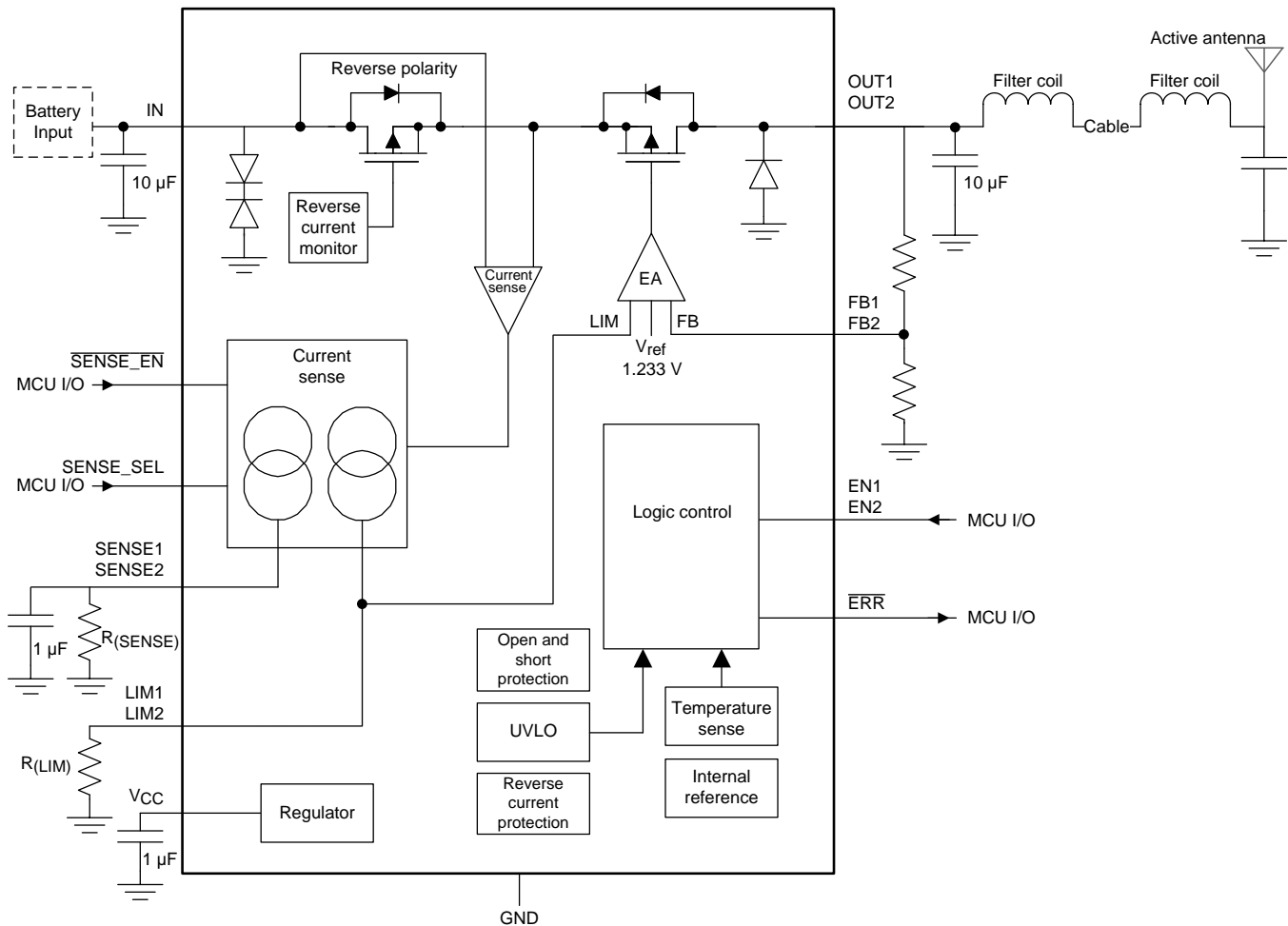

Figure 22. TPS7B770x-Q1 Typical Application

Typical Application (continued)

8.2.1 Design Requirements

For this design example, use the parameters listed in [Table 3](#) as the design parameters.

Table 3. Design Parameters

DESIGN PARAMETER	EXAMPLE VALUE
Input voltage range	4.5 to 40 V
Output voltage	1.5 to 20 V
Output capacitor range	2.2 to 100 μ F
Output Capacitor ESR range	0.001 to 5 Ω
SENSE resistor	See the Current Sense Resistor Selection section
Programmable current limit	50 to 300 mA

8.2.2 Detailed Design Procedure

To begin the design process, determine the following:

- Input voltage
- Output voltage
- Output current
- Current limit
- ADC voltage rating

8.2.2.1 Input Capacitor

The device requires an input decoupling capacitor, the value of which depends on the application. The typical recommended value for the decoupling capacitor is 10 μ F. The voltage rating must be greater than the maximum input voltage.

8.2.2.2 Output Capacitor

The device requires an output capacitor to stabilize the output voltage. The capacitor value should be between 2.2 μ F and 100 μ F. The ESR range should be between 1 m Ω and 5 Ω . TI recommends selecting a ceramic capacitor with low ESR to improve the load transient response.

8.2.2.3 Current Sense Resistor Selection

The current-sense outputs, SENSE_x (SENSE, SENSE1, and SENSE2), are proportional to the output current at the OUT, OUT1, and OUT2 pins with a factor of 1/198. An output resistor, R_(SENSE_x), must be connected between the SENSE_x pin and ground to generate a current sense voltage to be sampled by ADC. Use [Equation 2](#) to calculate the voltage at SENSE_x pin ($V_{(SENSEx)}$).

$$V_{(SENSEx)} = I_{(SENSEx)} \times R_{(SENSEx)}$$

where

$$I_{(SENSEx)} = \frac{I_{(OUTx)}}{198} \quad (2)$$

For this example, select 1.5 k Ω as a value for R_(SENSE_x). Do not consider the resistor and current-sense accuracy.

For a load current of 198 mA, use [Equation 3](#) to calculate the value of $V_{(SENSEx)}$.

$$I_{(SENSEx)} = \frac{198 \text{ mA}}{198} = 1 \text{ mA} \rightarrow V_{(SENSEx)} = 1 \text{ mA} \times 1.5 \text{ k}\Omega = 1.5 \text{ V} \quad (3)$$

To avoid any overlap between normal operation and current-limit or short-to-ground phase, using [Equation 4](#) to select the value of the SENSE resistor is recommended.

$$R_{(\text{SENSE}x)} \leq \frac{198 \times 2.4 \text{ V}}{I_{\text{Omax}}}$$

where

- 198 is the output current to current-sense ratio
- 2.4 V is the minimum possible voltage at the SENSE_x pin under a short-circuit fault case
- I_{Omax} is the maximum possible output current under normal operation (4)

To stabilize the current-sense loop, connecting a 1- μF ceramic capacitor at the SENSE, SENSE1, or SENSE2 pin is required. [Table 4](#) lists the current sense accuracy across temperature.

Table 4. Current Sense Accuracy

OUTPUT CURRENT	CURRENT SENSE ACCURACY
5 mA to 10 mA	20%
10 mA to 50 mA	10%
50 mA to 100 mA	5%
100 mA to 300 mA	3%

8.2.2.4 Current-Limit Resistor Selection

The current at the LIM_x pins (LIM, LIM1, and LIM2) is proportional to the load current at the OUT_x (OUT, OUT1, and OUT2) pins and is internally connected to a current-limit comparator referenced to 1.233 V. The current limit is programmable through the external resistor connected at LIM_x pin. Use [Equation 5](#) to calculate the value of the external resistor, $R_{(\text{LIM}x)}$. The programmable current limit accuracy is 8% maximum across all conditions. The internal current limit of the device is set by shorting the LIM pin to ground. Because the current limit varies by 8%, [Equation 6](#) shows how to calculate the minimum current limit value, and [Equation 7](#) shows how to calculate the maximum current limit value.

$$R_{(\text{LIM}x)} = \frac{1.233 \text{ V}}{I_{(\text{LIM}x)}} \times 198$$

where

$$\bullet \quad I_{(\text{LIM}x)(\text{typ})} = \frac{1.233 \text{ V}}{R_{(\text{LIM}x)}} \times 198 \quad (5)$$

$$I_{(\text{LIM}x)(\text{min})} = I_{(\text{LIM}x)(\text{typ})} \times 0.92 = (0.92) \left(\frac{1.233 \text{ V}}{R_{(\text{LIM}x)}} \times 198 \right) \quad (6)$$

$$I_{(\text{LIM}x)(\text{max})} = I_{(\text{LIM}x)(\text{typ})} \times 1.08 = (1.08) \left(\frac{1.233 \text{ V}}{R_{(\text{LIM}x)}} \times 198 \right) \quad (7)$$

Select a maximum current-limit value of 200 mA and use [Equation 8](#) to calculate the value of $R_{(\text{LIM}x)}$.

$$R_{(\text{LIM}x)} = \frac{1.08 \times 198 \times 1.233 \text{ V}}{I_{(\text{LIM}x)(\text{max})}} \quad (8)$$

Using [Equation 8](#) yields a $R_{\text{LIM}x}$ value of 1.318 k Ω . The closest 1% resistor that can be selected is 1.33 k Ω . Now using [Equation 7](#) and plugging in 1.33 k Ω for $R_{\text{LIM}x}$ yields a maximum current of 198.2 mA. Keep in mind this result does not include resistor tolerance in the calculation. To make sure that the current does not exceed the set amount, resistor tolerance must also be included in the equation.

8.2.3 Application Curves

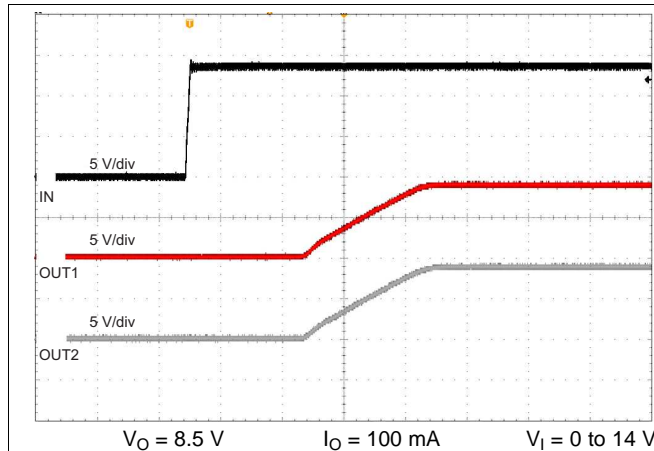
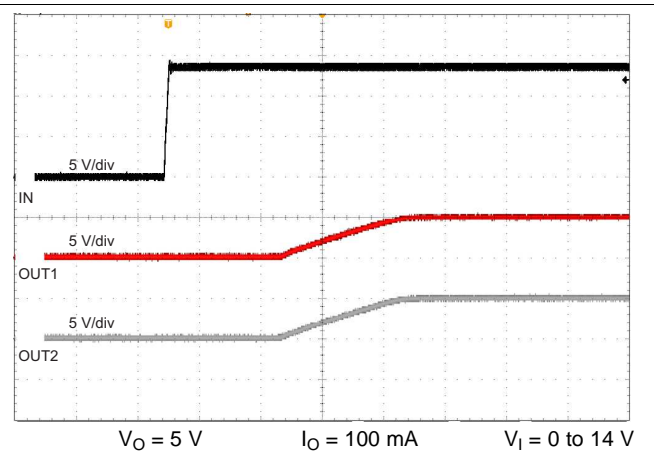
Figure 23. Power Up (1 V/μs)

Figure 24. Power Up (1 V/μs)

9 Power Supply Recommendations

The device is designed to operate from an input voltage supply with a range between 4.5 V and 40 V. This input supply must be well regulated. If the input supply is located more than a few inches from the TPS7B770x-Q1 device, TI recommends adding an 10-μF electrolytic capacitor and a ceramic bypass capacitor at the input.

10 Layout

10.1 Layout Guidelines

For the layout of TPS7B770x-Q1 device, place the input and output capacitors close to the device as shown in [Figure 25](#). To enhance the thermal performance, TI recommends surrounding the device with some vias.

Minimize equivalent-series inductance (ESL) and ESR to maximize performance and provide stability. Place every capacitor as close as possible to the device and on the same side of the PCB as the regulator.

Do not place any of the capacitors on the opposite side of the PCB from where the regulator is installed. TI strongly discourages the use long traces because they can negatively impact system performance and cause instability.

If possible, and to maintain the maximum performance specified in this device data sheet, use the same layout pattern used for the TPS7B770x-Q1 evaluation board, available online at www.ti.com/tool/TPS7B7702EVM.

10.2 Layout Example

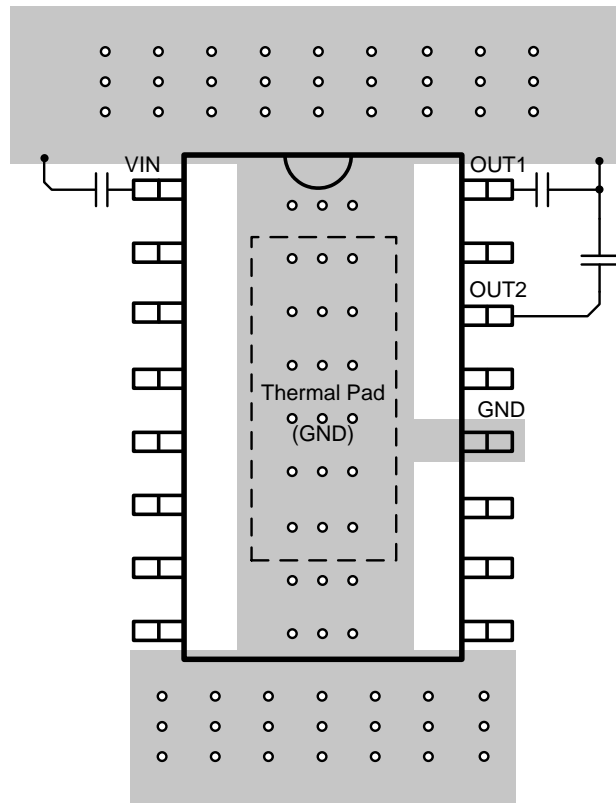

Figure 25. TPS7B770x-Q1 Layout Example

11 Device and Documentation Support

11.1 Documentation Support

11.1.1 Related Documentation

For related documentation see the following:

[TPS7B7702-Q1 Evaluation Module User's Guide](#)

11.2 Related Links

[Table 5](#) lists quick access links. Categories include technical documents, support and community resources, tools and software, and quick access to sample or buy.

Table 5. Related Links

PARTS	PRODUCT FOLDER	SAMPLE & BUY	TECHNICAL DOCUMENTS	TOOLS & SOFTWARE	SUPPORT & COMMUNITY
TPS7B7701-Q1	Click here	Click here	Click here	Click here	Click here
TPS7B7702-Q1	Click here	Click here	Click here	Click here	Click here

11.3 Receiving Notification of Documentation Updates

To receive notification of documentation updates, navigate to the device product folder on ti.com. In the upper right corner, click on *Alert me* to register and receive a weekly digest of any product information that has changed. For change details, review the revision history included in any revised document.

11.4 Community Resources

The following links connect to TI community resources. Linked contents are provided "AS IS" by the respective contributors. They do not constitute TI specifications and do not necessarily reflect TI's views; see TI's [Terms of Use](#).

TI E2E™ Online Community *TI's Engineer-to-Engineer (E2E) Community*. Created to foster collaboration among engineers. At e2e.ti.com, you can ask questions, share knowledge, explore ideas and help solve problems with fellow engineers.

Design Support *TI's Design Support* Quickly find helpful E2E forums along with design support tools and contact information for technical support.

11.5 Trademarks

PowerPAD, E2E are trademarks of Texas Instruments.
All other trademarks are the property of their respective owners.

11.6 Electrostatic Discharge Caution



These devices have limited built-in ESD protection. The leads should be shorted together or the device placed in conductive foam during storage or handling to prevent electrostatic damage to the MOS gates.

11.7 Glossary

[SLYZ022](#) — *TI Glossary*.

This glossary lists and explains terms, acronyms, and definitions.

12 Mechanical, Packaging, and Orderable Information

The following pages include mechanical, packaging, and orderable information. This information is the most current data available for the designated devices. This data is subject to change without notice and revision of this document. For browser-based versions of this data sheet, refer to the left-hand navigation.

PACKAGING INFORMATION

Orderable Device	Status (1)	Package Type	Package Drawing	Pins	Package Qty	Eco Plan (2)	Lead/Ball Finish (6)	MSL Peak Temp (3)	Op Temp (°C)	Device Marking (4/5)	Samples
TPS7B7701QPWPRQ1	ACTIVE	HTSSOP	PWP	16	2000	Green (RoHS & no Sb/Br)	CU NIPDAU	Level-3-260C-168 HR	-40 to 125	7B7701	Samples
TPS7B7702QPWPRQ1	ACTIVE	HTSSOP	PWP	16	2000	Green (RoHS & no Sb/Br)	CU NIPDAU	Level-3-260C-168 HR	-40 to 125	7B7702	Samples

(1) The marketing status values are defined as follows:

ACTIVE: Product device recommended for new designs.

LIFEBUY: TI has announced that the device will be discontinued, and a lifetime-buy period is in effect.

NRND: Not recommended for new designs. Device is in production to support existing customers, but TI does not recommend using this part in a new design.

PREVIEW: Device has been announced but is not in production. Samples may or may not be available.

OBSOLETE: TI has discontinued the production of the device.

(2) **RoHS:** TI defines "RoHS" to mean semiconductor products that are compliant with the current EU RoHS requirements for all 10 RoHS substances, including the requirement that RoHS substance do not exceed 0.1% by weight in homogeneous materials. Where designed to be soldered at high temperatures, "RoHS" products are suitable for use in specified lead-free processes. TI may reference these types of products as "Pb-Free".

RoHS Exempt: TI defines "RoHS Exempt" to mean products that contain lead but are compliant with EU RoHS pursuant to a specific EU RoHS exemption.

Green: TI defines "Green" to mean the content of Chlorine (Cl) and Bromine (Br) based flame retardants meet JS709B low halogen requirements of <=1000ppm threshold. Antimony trioxide based flame retardants must also meet the <=1000ppm threshold requirement.

(3) MSL, Peak Temp. - The Moisture Sensitivity Level rating according to the JEDEC industry standard classifications, and peak solder temperature.

(4) There may be additional marking, which relates to the logo, the lot trace code information, or the environmental category on the device.

(5) Multiple Device Markings will be inside parentheses. Only one Device Marking contained in parentheses and separated by a "~" will appear on a device. If a line is indented then it is a continuation of the previous line and the two combined represent the entire Device Marking for that device.

(6) Lead/Ball Finish - Orderable Devices may have multiple material finish options. Finish options are separated by a vertical ruled line. Lead/Ball Finish values may wrap to two lines if the finish value exceeds the maximum column width.

Important Information and Disclaimer:The information provided on this page represents TI's knowledge and belief as of the date that it is provided. TI bases its knowledge and belief on information provided by third parties, and makes no representation or warranty as to the accuracy of such information. Efforts are underway to better integrate information from third parties. TI has taken and continues to take reasonable steps to provide representative and accurate information but may not have conducted destructive testing or chemical analysis on incoming materials and chemicals. TI and TI suppliers consider certain information to be proprietary, and thus CAS numbers and other limited information may not be available for release.

In no event shall TI's liability arising out of such information exceed the total purchase price of the TI part(s) at issue in this document sold by TI to Customer on an annual basis.

TAPE AND REEL INFORMATION



QUADRANT ASSIGNMENTS FOR PIN 1 ORIENTATION IN TAPE



*All dimensions are nominal

Device	Package Type	Package Drawing	Pins	SPQ	Reel Diameter (mm)	Reel Width W1 (mm)	A0 (mm)	B0 (mm)	K0 (mm)	P1 (mm)	W (mm)	Pin1 Quadrant
TPS7B7701QPWPRQ1	HTSSOP	PWP	16	2000	330.0	12.4	6.9	5.6	1.6	8.0	12.0	Q1
TPS7B7702QPWPRQ1	HTSSOP	PWP	16	2000	330.0	12.4	6.9	5.6	1.6	8.0	12.0	Q1

TAPE AND REEL BOX DIMENSIONS

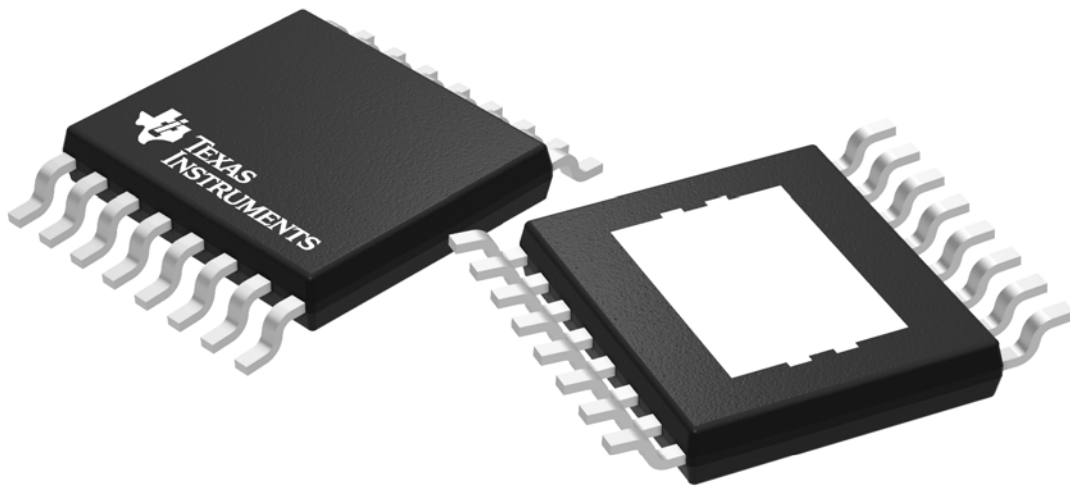

*All dimensions are nominal

Device	Package Type	Package Drawing	Pins	SPQ	Length (mm)	Width (mm)	Height (mm)
TPS7B7701QPWPRQ1	HTSSOP	PWP	16	2000	350.0	350.0	43.0
TPS7B7702QPWPRQ1	HTSSOP	PWP	16	2000	350.0	350.0	43.0

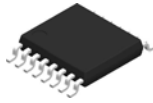

Images above are just a representation of the package family, actual package may vary.
Refer to the product data sheet for package details.

PWP0016J



PACKAGE OUTLINE

PowerPAD™ TSSOP - 1.2 mm max height

SMALL OUTLINE PACKAGE

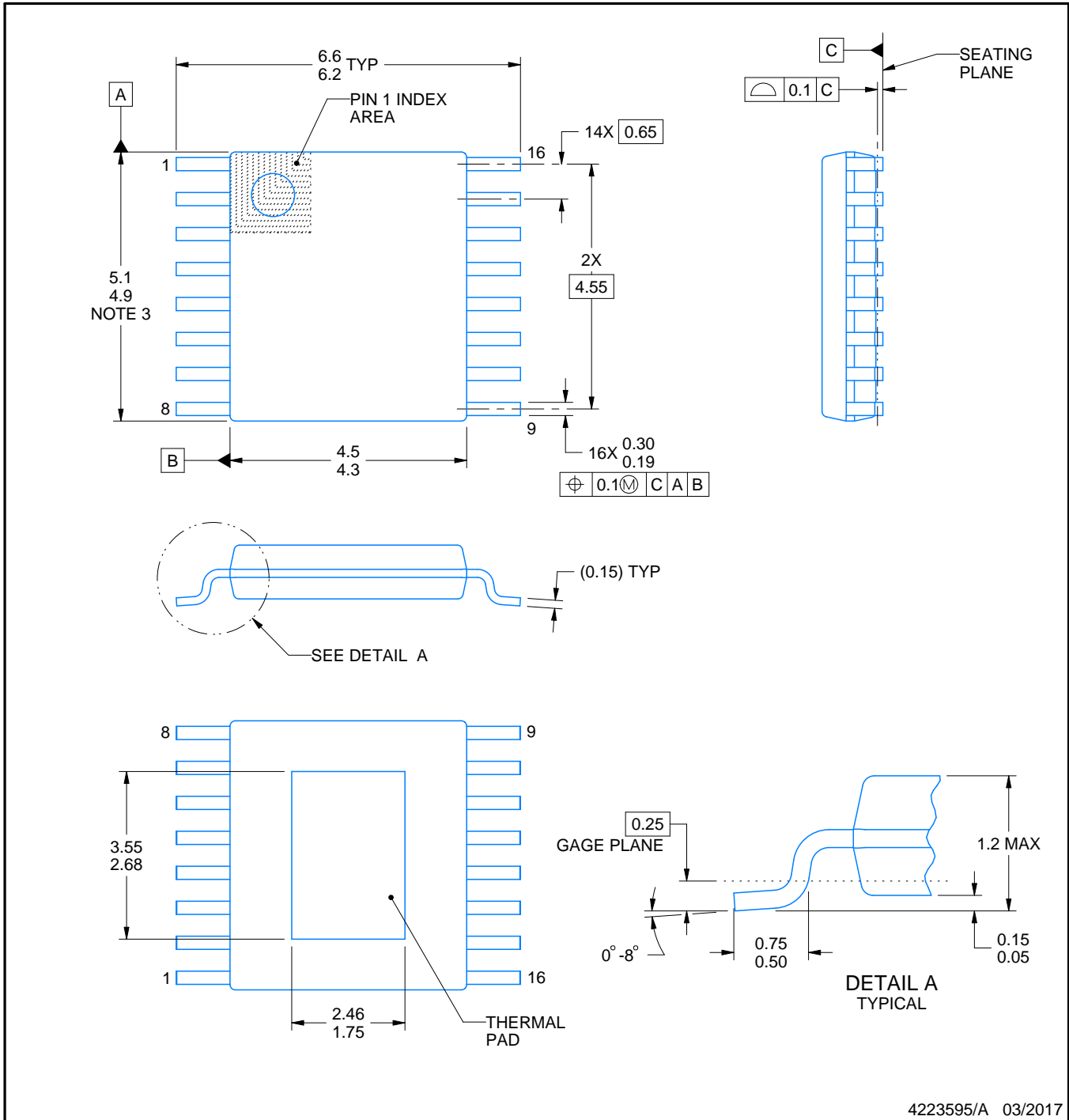

4223595/A 03/2017

NOTES:

PowerPAD is a trademark of Texas Instruments.

1. All linear dimensions are in millimeters. Any dimensions in parenthesis are for reference only. Dimensioning and tolerancing per ASME Y14.5M.
2. This drawing is subject to change without notice.
3. This dimension does not include mold flash, protrusions, or gate burrs. Mold flash, protrusions, or gate burrs shall not exceed 0.15 mm per side.
4. Reference JEDEC registration MO-153.

EXAMPLE BOARD LAYOUT

PWP0016J

PowerPAD™ TSSOP - 1.2 mm max height

SMALL OUTLINE PACKAGE

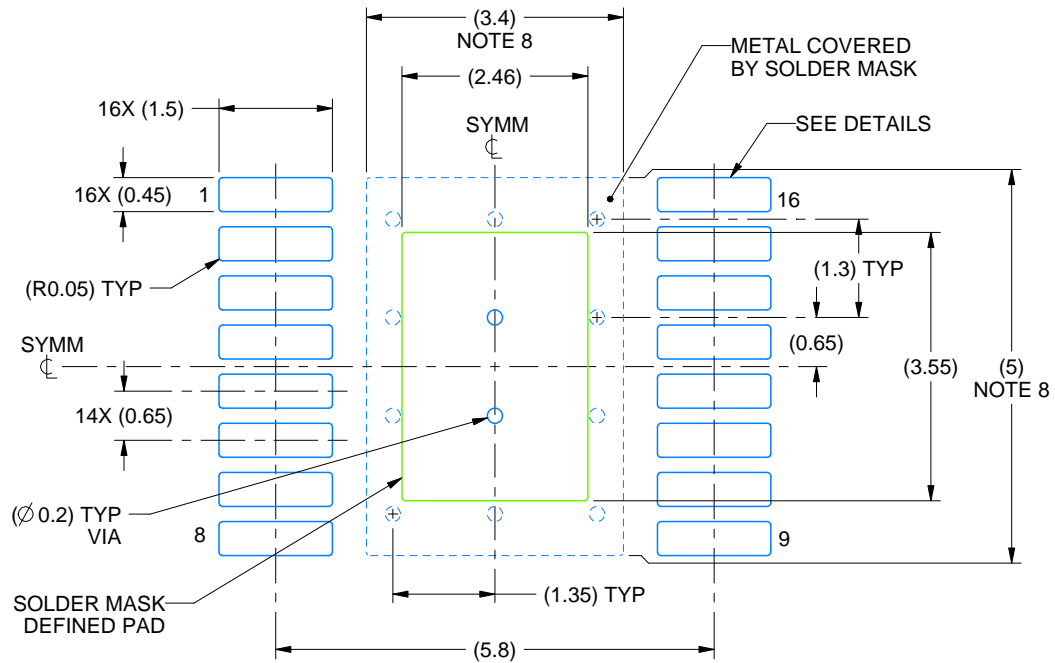

LAND PATTERN EXAMPLE
EXPOSED METAL SHOWN
SCALE: 10X

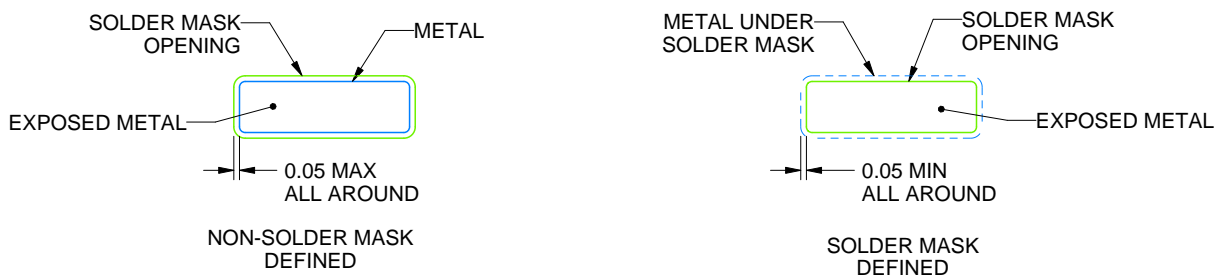

SOLDER MASK DETAILS

4223595/A 03/2017

NOTES: (continued)

5. Publication IPC-7351 may have alternate designs.
6. Solder mask tolerances between and around signal pads can vary based on board fabrication site.
7. This package is designed to be soldered to a thermal pad on the board. For more information, see Texas Instruments literature numbers SLMA002 (www.ti.com/lit/slma002) and SLMA004 (www.ti.com/lit/slma004).
8. Size of metal pad may vary due to creepage requirement.
9. Vias are optional depending on application, refer to device data sheet. It is recommended that vias under paste be filled, plugged or tented.

EXAMPLE STENCIL DESIGN

PWP0016J

PowerPAD™ TSSOP - 1.2 mm max height

SMALL OUTLINE PACKAGE

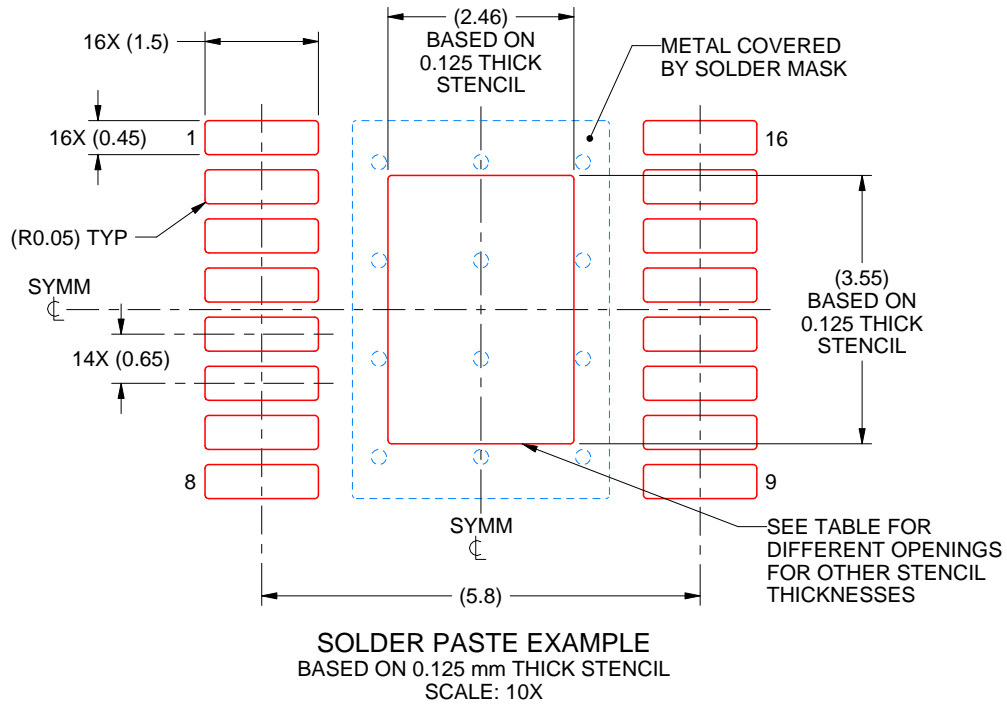

STENCIL THICKNESS	SOLDER STENCIL OPENING
0.1	2.75 X 3.97
0.125	2.46 X 3.55 (SHOWN)
0.15	2.25 X 3.24
0.175	2.08 X 3.00

4223595/A 03/2017

NOTES: (continued)

10. Laser cutting apertures with trapezoidal walls and rounded corners may offer better paste release. IPC-7525 may have alternate design recommendations.
11. Board assembly site may have different recommendations for stencil design.

IMPORTANT NOTICE AND DISCLAIMER

TI PROVIDES TECHNICAL AND RELIABILITY DATA (INCLUDING DATASHEETS), DESIGN RESOURCES (INCLUDING REFERENCE DESIGNS), APPLICATION OR OTHER DESIGN ADVICE, WEB TOOLS, SAFETY INFORMATION, AND OTHER RESOURCES "AS IS" AND WITH ALL FAULTS, AND DISCLAIMS ALL WARRANTIES, EXPRESS AND IMPLIED, INCLUDING WITHOUT LIMITATION ANY IMPLIED WARRANTIES OF MERCHANTABILITY, FITNESS FOR A PARTICULAR PURPOSE OR NON-INFRINGEMENT OF THIRD PARTY INTELLECTUAL PROPERTY RIGHTS.

These resources are intended for skilled developers designing with TI products. You are solely responsible for (1) selecting the appropriate TI products for your application, (2) designing, validating and testing your application, and (3) ensuring your application meets applicable standards, and any other safety, security, or other requirements. These resources are subject to change without notice. TI grants you permission to use these resources only for development of an application that uses the TI products described in the resource. Other reproduction and display of these resources is prohibited. No license is granted to any other TI intellectual property right or to any third party intellectual property right. TI disclaims responsibility for, and you will fully indemnify TI and its representatives against, any claims, damages, costs, losses, and liabilities arising out of your use of these resources.

TI's products are provided subject to TI's Terms of Sale (www.ti.com/legal/termsofsale.html) or other applicable terms available either on ti.com or provided in conjunction with such TI products. TI's provision of these resources does not expand or otherwise alter TI's applicable warranties or warranty disclaimers for TI products.

Mailing Address: Texas Instruments, Post Office Box 655303, Dallas, Texas 75265
Copyright © 2019, Texas Instruments Incorporated

Looking for pricing, stock, or lifecycle information?

Click below to explore more details on WIN SOURCE:

 [View TPS7B7701QPWPRQ1 on WIN SOURCE](#)

 [Texas Instruments](#) Information

Optimize Your Supply Chain with WIN SOURCE Solutions

-  Global Sourcing Solution
-  Obsolete Management
-  Cost Control Management
-  Shortage Management
-  Alternative Solution
-  Excess Inventory Management