



**THE DATASHEET OF
TPS7A6333QPWPRQ1**



TPS7A63-Q1, TPS7A6401-Q1

300-mA, 40-V, Low-Dropout Regulator With Ultra-Low I_Q

1 Features

- Qualified for Automotive Applications
- AEC-Q100 Test Guidance With the Following Results:
 - Device Temperature Grade 1: -40°C to 125°C Ambient Operating Temperature
 - Device HBM ESD Classification Level H2
 - Device CDM ESD Classification Level C2
- Low Dropout Voltage
 - 300 mV at $I_{\text{OUT}} = 150$ mA
- 11-V to 40-V Wide Input-Voltage Range With up to 45-V Transients
- 300-mA Maximum Output Current
- Ultralow Quiescent Current
 - $I_{\text{QUIESCENT}} = 35$ μA (Typical) at Light Loads
 - $I_{\text{SLEEP}} < 2$ μA When EN = Low
- Fixed (3.3-V and 5-V) and Adjustable (2.5-V to 7-V) Output Voltages
- Integrated Watchdog With Fault/Flag
- Stable With Low-ESR Ceramic Output Capacitor
- Integrated Power-On Reset
 - Programmable Delay
 - Open-Drain Reset Output
- Integrated Fault Protection
 - Short-Circuit and Overcurrent Protection
 - Thermal Shutdown
- Low Input-Voltage Tracking
- Thermally Enhanced 14-Pin HTSSOP-PWP Package and 10-Pin VSON-DRK Package

2 Applications

- Infotainment Systems With Sleep Mode
- Body Control Modules
- Always-On Battery Applications
 - Gateway Applications
 - Remote Keyless Entry Systems
 - Immobilizers

3 Description

The TPS7A63-Q1 and TPS7A6401-Q1 are a family of low-dropout linear voltage regulators designed for low power consumption and quiescent current less than 35 μA in light-load applications. These devices, designed to achieve stable operation even with a low-ESR ceramic output capacitor, feature an integrated programmable window watchdog and overcurrent protection. Designers can program the output voltage using external resistors. A low-voltage tracking feature allows for a smaller input capacitor and can possibly eliminate the need of using a boost converter during cold-crank conditions. The power-on-reset delay is fixed (250 μs typical), or an external capacitor can program the delay. Because of such features, these devices are well-suited in power supplies for various automotive applications.

Device Information⁽¹⁾

PART NUMBER	PACKAGE	BODY SIZE (NOM)
TPS7A63-Q1, TPS7A6401-Q1	HTSSOP (14)	5.00 mm x 4.40 mm
TPS7A63-Q1	VSON (10)	4.00 mm x 3.00 mm

(1) For all available packages, see the orderable addendum at the end of the data sheet.

Fixed Output Voltage Option

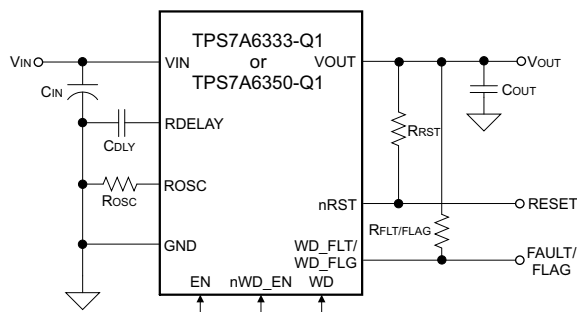

Adjustable Output Voltage Option

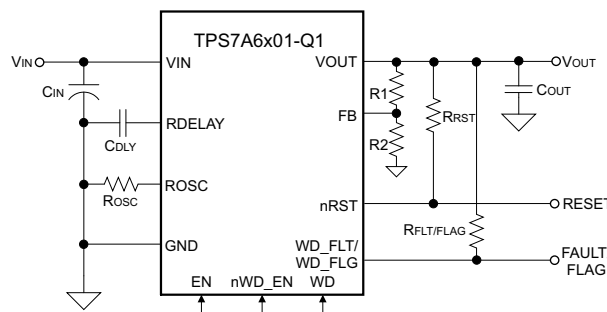

Table of Contents

1 Features	1	7.4 Device Functional Modes.....	20
2 Applications	1	8 Application and Implementation	21
3 Description	1	8.1 Application Information.....	21
4 Revision History	2	8.2 Typical Applications	21
5 Pin Configuration and Functions	4	9 Power Supply Recommendations	24
6 Specifications	5	10 Layout	24
6.1 Absolute Maximum Ratings	5	10.1 Layout Guidelines	24
6.2 ESD Ratings.....	5	10.2 Layout Example	27
6.3 Recommended Operating Conditions.....	5	11 Device and Documentation Support	28
6.4 Thermal Information	6	11.1 Related Links	28
6.5 Electrical Characteristics.....	6	11.2 Receiving Notification of Documentation Updates	28
6.6 Typical Characteristics	8	11.3 Community Resources.....	28
7 Detailed Description	10	11.4 Trademarks	28
7.1 Overview	10	11.5 Electrostatic Discharge Caution.....	28
7.2 Functional Block Diagrams	10	11.6 Glossary	28
7.3 Feature Description.....	12	12 Mechanical, Packaging, and Orderable Information	28

4 Revision History

NOTE: Page numbers for previous revisions may differ from page numbers in the current version.

Changes from Revision E (September 2015) to Revision F	Page
• Changed device names to TPS7A63-Q1 TPS7A6401-Q1	1
• Changed 4 V to 11 V in fourth <i>Features</i> bullet	1
• Changed V_{IN} , V_{EN} parameter row in <i>Recommended Operating Conditions</i> table: separated V_{IN} and V_{EN} into different rows, changed V_{IN} minimum specification from 4 V to 11 V	5
• Changed V_{IN} minimum specification from $V_{OUT} + 0.3$ V to 11 V in <i>Electrical Characteristics</i> table	6
• Changed 4 V to 11 V in <i>Example values</i> column of <i>Input voltage range</i> row of <i>Design Parameters</i> table	22
• Changed 4 V to 11 V in <i>Example values</i> column of <i>Input voltage range</i> row of <i>Design Parameters</i> table	23
• Changed 4 V to 11 V in first sentence of <i>Power Supply Recommendations</i> section	24

Changes from Revision D (July 2012) to Revision E	Page
• Added <i>ESD Ratings</i> table, <i>Feature Description</i> section, <i>Device Functional Modes</i> , <i>Application and Implementation</i> section, <i>Power Supply Recommendations</i> section, <i>Layout</i> section, <i>Device and Documentation Support</i> section, and <i>Mechanical, Packaging, and Orderable Information</i> section	5

Changes from Revision C (April 2012) to Revision D	Page
• Added new bullets at top of <i>Features</i> list	1
• Corrected part number in numerous locations throughout the data sheet.....	1
• Deleted the NO. column from the electrical tables.....	5
• Deleted two Typical Characteristics graphs	8

Changes from Revision B (December 2011) to Revision C	Page
• Changed regulated output voltage (6.1), added text to the test conditions (10mA to 200mA, $V_{IN} = V_{OUT} + 1$ V to 16V)	6

Changes from Revision A (August 2011) to Revision B**Page**

-
- Deleted devices TPS7A64333-Q1 and TPSA6450-Q1 1
-

Changes from Original (June 2011) to Revision A**Page**

-
- Deleted the Ordering Information Table 4
 - Changed values for V_{IL} and V_{IH} in the Watchdog Enable Input (nWD_EN pin) section..... 7
 - Changed values for V_{IL} and V_{IH} in the Watchdog Input Pulse (WD pin) section 7
-

5 Pin Configuration and Functions

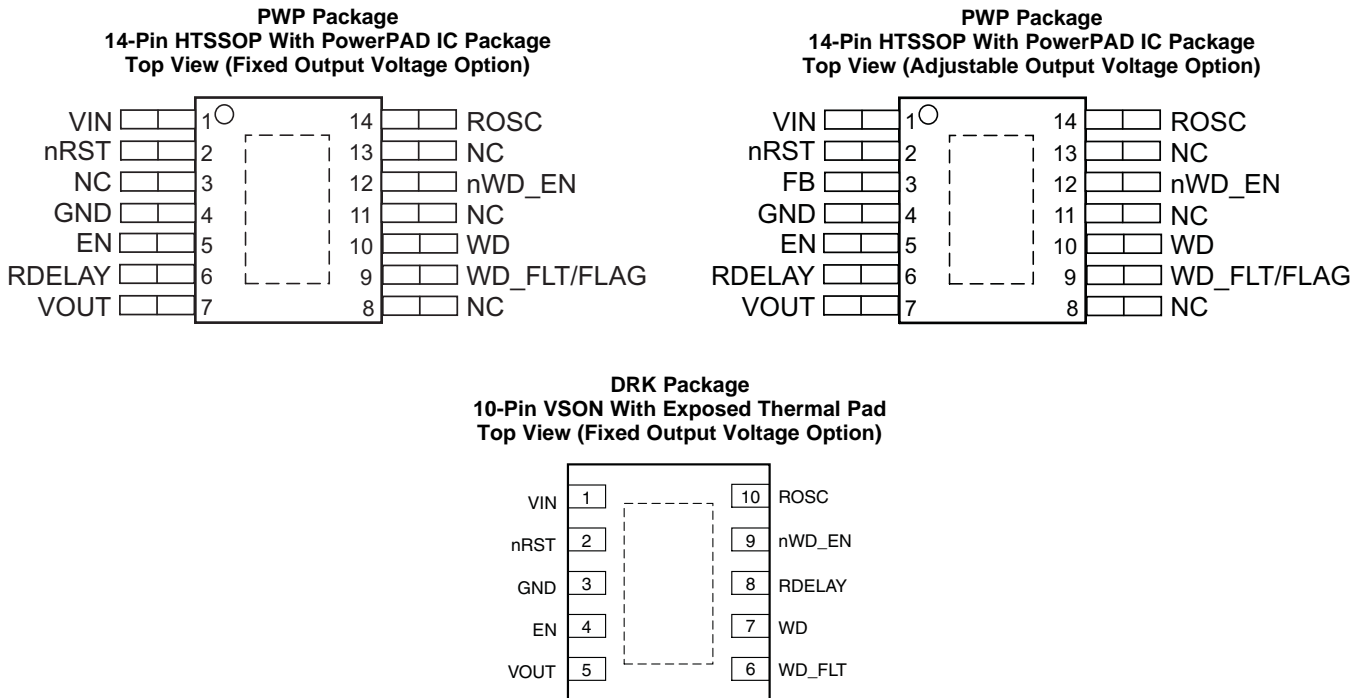

Pin Functions

PIN		I/O	DESCRIPTION	
NAME	PWP			DRK
EN	5	4	I	Chip enable pin: This is a high-voltage-tolerant input pin with an internal pull-down. A high input to this pin activates the device and turns the regulator ON. Connect this input to the VIN terminal for self-bias applications. If this pin remains unconnected, the device stays disabled.
FB	3	—	I	Feedback pin (only applicable for TPS7A6x01-Q1): Sense voltage for error amplifier
GND	4	3	I/O	Ground pin: This is signal ground pin of the device.
NC	3	—	—	Not connected (only applicable for TPS7A6333-Q1 and TPS7A6350-Q1)
NC	8	—	—	Not connected
NC	11	—	—	Not connected
NC	13	—	—	Not connected
nRST	2	2	O	Reset pin: This is an open-drain reset output pin with an external pullup resistor connected to the VOUT pin.
nWD_EN	12	9	I	Watchdog enable pin: A high input to this pin disables the watchdog, and vice versa. This is an active-low input pin with an internal pull-down. Leaving this pin is unconnected and floating keeps the watchdog enabled. An external microcontroller can pull this pin high momentarily to disable and reinitialize the watchdog.
RDELAY	6	8	O	Reset delay timer pin: This pin programs the reset delay timer using an external capacitor (C_{DLY}) to ground.
ROSC	14	10	O	ROscillator pin: This pin programs the internal oscillator frequency (and hence the duration of the watchdog window) by connecting an external resistor to ground.
WD	10	7	I	Watchdog service pin: This is an input pin to provide a service signal to the watchdog.
WD_FLAG	9	6	O	Watchdog flag pin (for TPS7A6401-Q1 only): This is an active-high latched fault (that is, flag) output pin with an external pullup resistor connected to VOUT pin.
WD_FLT	9	6	O	Watchdog fault pin (for TPS7A63-Q1 only): This is an active-low fault output pin with an external pullup resistor connected to the VOUT pin.
VIN	1	1	I	Input voltage pin: The unregulated input voltage is supplied to this pin. A bypass capacitor connected between the VIN pin and GND pin dampens line transients on the input.
VOUT	7	5	O	Regulated output voltage pin: This is a regulated voltage output ($V_{OUT} = 3.3\text{ V}$ or 5 V or a programmed value) pin with a limitation on maximum output current. For devices with adjustable output voltage (TPS7A6x01-Q1), connecting an external resistor network programs the output voltage. In order to achieve stable operation and prevent oscillation, connect an external output capacitor (C_{OUT}) with low ESR between this pin and GND pin.

6 Specifications

6.1 Absolute Maximum Ratings

over operating free-air temperature range (unless otherwise noted)⁽¹⁾

DESCRIPTION		MIN	MAX	UNIT
V _{IN} , V _{EN}	Unregulated inputs ⁽²⁾⁽³⁾		45	V
V _{OUT}	Regulated output		7	V
FB	Sense voltage for error amplifier ⁽²⁾		7	V
ROSC	Constant-voltage reference ⁽²⁾		7	V
nWD_EN, WD, WD_FLAG, WD_FLT	Watchdog inputs and outputs ⁽²⁾		7	V
nRST	Open-drain reset output ⁽²⁾		7	V
RDELAY	Reset delay timer output ⁽²⁾		7	V
T _A	Operating ambient temperature		125	°C
T _{stg}	Storage temperature	-65	150	°C

- (1) Stresses beyond those listed under *Absolute Maximum Ratings* may cause permanent damage to the device. These are stress ratings only, and functional operation of the device at these or any other conditions beyond those indicated under *Recommended Operating Conditions* is not implied. Exposure to absolute-maximum-rated conditions for extended periods may affect device reliability. All voltage values are with respect to GND.
- (2) Absolute negative voltage on these pins not to go below -0.3 V.
- (3) Absolute maximum voltage for duration less than 480 ms.

6.2 ESD Ratings

		VALUE	UNIT
V _(ESD)	Electrostatic discharge	Human body model (HBM), per AEC Q100-002 ⁽¹⁾	±4000
		Charged device model (CDM), per AEC Q100-011	±1500

- (1) AEC Q100-002 indicates HBM stressing is done in accordance with the ANSI/ESDA/JEDEC JS-001 specification.

6.3 Recommended Operating Conditions

		MIN	MAX	UNIT
V _{IN}	Unregulated input voltage	11	40	V
V _{EN}	Enable pin voltage	4	40	V
nRST, RDELAY, nWD_EN, WD_FLT ⁽¹⁾ , WD_FLAG ⁽²⁾ , WD, FB ⁽³⁾	Low voltage input or output	0	5.25	V
T _J	Operating junction temperature range	-40	150	°C

- (1) Applicable for TPS7A63-Q1 only
- (2) Applicable for TPS7A6401-Q1 only
- (3) Applicable for TPS7A6301-Q1 and TPS7A6401-Q1 only

6.4 Thermal Information

THERMAL METRIC ⁽¹⁾		TPS7A6401-Q1 TPS7A63-Q1		UNIT
		PWP (HTTSOP)	DRK (VSON)	
		14 PINS	10 PINS	
R _{θJA}	Junction-to-ambient thermal resistance	46	36.5	°C/W
R _{θJC(top)}	Junction-to-case (top) thermal resistance	32.6	36.6	°C/W
R _{θJB}	Junction-to-board thermal resistance	27.4	11.6	°C/W
ψ _{JT}	Junction-to-top characterization parameter	1.2	0.5	°C/W
ψ _{JB}	Junction-to-board characterization parameter	27.2	11.7	°C/W
R _{θJC(bot)}	Junction-to-case (bottom) thermal resistance	2.5	3.8	°C/W

(1) For more information about traditional and new thermal metrics, see the [Semiconductor and IC Package Thermal Metrics](#) application report.

6.5 Electrical Characteristics

V_{IN} = 14 V, T_J = –40°C to 150°C (unless otherwise noted)

PARAMETER		TEST CONDITIONS	MIN	TYP	MAX	UNIT
INPUT VOLTAGE (VIN PIN)						
V _{IN}	Input voltage	V _{OUT} = 2.5 V to 7 V, I _{OUT} = 1 mA	11		40	V
I _{QUIESCENT}	Quiescent current	V _{IN} = 8.2 V to 18 V, V _{EN} = 5 V, I _{OUT} = 0.01 mA to 0.75 mA		35		μA
I _{SLEEP}	Sleep or shutdown current	V _{IN} = 8.2 V to 18 V, V _{EN} < 0.8 V, I _{OUT} = 0 mA (no load), T _A = 125°C			3	μA
V _{IN-UVLO}	Undervoltage lockout voltage	Ramp V _{IN} down until output is turned OFF		3.16		V
V _{IN(POWERUP)}	Power-up voltage	Ramp V _{IN} up until output is turned ON		3.45		V
DEVICE ENABLE INPUT (EN PIN)						
V _{IL}	Logic-input low level		0		0.8	V
V _{IH}	Logic-input high level		2.5		40	V
REGULATED OUTPUT VOLTAGE (VOUT PIN)						
V _{OUT}	Regulated output voltage	Fixed V _{OUT} value (3.3 V, 5 V or a programmed value), I _{OUT} = 10 mA to 200 mA, V _{IN} = V _{OUT} + 1 V to 16 V	–2%		2%	
ΔV _{LINE-REG}	Line regulation	V _{IN} = 6 V to 28 V, I _{OUT} = 10 mA, V _{OUT} = 5 V			15	mV
		V _{IN} = 6 V to 28 V, I _{OUT} = 10 mA, V _{OUT} = 3.3 V			20	
ΔV _{LOAD-REG}	Load regulation	I _{OUT} = 10 mA to 200 mA, V _{IN} = 14 V, V _{OUT} = 5 V			25	mV
		I _{OUT} = 10 mA to 200 mA, V _{IN} = 14 V, V _{OUT} = 3.3 V			35	
V _{DROPOUT}	Dropout voltage (V _{IN} – V _{OUT})	I _{OUT} = 200 mA			500	mV
		I _{OUT} = 150 mA			300	
R _{SW} ⁽¹⁾	Switch resistance	V _{IN} to V _{OUT} resistance			2	Ω
I _{OUT}	Output current	V _{OUT} in regulation	0		200	mA
		[V _{OUT} in regulation, V _{OUT} = 3.3 V, V _{IN} = 6 V] ⁽²⁾	0		300	
I _{CL}	Output current limit	V _{OUT} = 0 V (V _{OUT} pin is shorted to ground)	350		1000	mA
PSRR ⁽³⁾	Power-supply ripple rejection	V _{IN-RIPPLE} = 0.5 V _{pp} , I _{OUT} = 200 mA, frequency = 100 Hz, V _{OUT} = 5 V and V _{OUT} = 3.3 V		60		dB
		V _{IN-RIPPLE} = 0.5 V _{pp} , I _{OUT} = 200 mA, frequency = 150 kHz, V _{OUT} = 5 V and V _{OUT} = 3.3 V		30		

(1) This test is done with V_{OUT} in regulation, measuring the V_{IN} – V_{OUT} parameter when V_{OUT} drops by 100 mV from the programmed value (of V_{OUT}) at specified loads.

(2) Design Information - not tested; specified by characterization.

(3) Specified by design - not tested.

Electrical Characteristics (continued)
 $V_{IN} = 14\text{ V}$, $T_J = -40^{\circ}\text{C}$ to 150°C (unless otherwise noted)

PARAMETER		TEST CONDITIONS	MIN	TYP	MAX	UNIT
RESET (nRST PIN)						
V_{OL}	Reset pulled low	$I_{OL} = 5\text{ mA}$			0.4	V
I_{OH}	Leakage current	Reset pulled to V_{OUT} through a 5-k Ω resistor			1	μA
$V_{TH(POR)}$	Power-on-reset threshold	V_{OUT} powered up above internally set tolerance, $V_{OUT} = 5\text{ V}$	4.5	4.65	4.77	V
		V_{OUT} powered up above internally set tolerance, $V_{OUT} = 3.3\text{ V}$		3.07		
UV_{THRES}	Reset threshold	V_{OUT} falling below internally set tolerance, $V_{OUT} = 5\text{ V}$	4.5	4.65	4.77	V
		V_{OUT} falling below internally set tolerance, $V_{OUT} = 3.3\text{ V}$		3.07		
$t_{POR}^{(2)}$	Power-on-reset delay	$C_{DLY} = 100\text{ pF}$		300		μs
		$C_{DLY} = 100\text{ nF}$		300		ms
$t_{POR-PRESET}$	Internally preset Power-on-reset delay	C_{DLY} not connected, $V_{OUT} = 5\text{ V}$ and $V_{OUT} = 3.3\text{ V}$		250		μs
$t_{DEGLITCH}$	Reset deglitch time			5.5		μs
RESET DELAY (RDELAY PIN)						
$V_{TH(RDELAY)}$	Threshold to release nRST high	Voltage at RDELAY pin is ramped up		3	3.3	V
I_{DLY}	Delay capacitor charging current		0.75	1	1.25	μA
I_{OL}	Delay capacitor discharging current	Voltage at RDELAY pin = 1 V	5			mA
CURRENT VOLTAGE REFERENCE (ROSC PIN)						
V_{ROSC}	Voltage reference		0.95	1	1.05	V
WATCHDOG FAULT / FLAG OUTPUT (WD_FLT / WD_FLAG Pin)						
V_{OL}	Logic output low level	$I_{OL} = 5\text{ mA}$			0.4	V
I_{OH}	Leakage current	WD_FLT/WD_FLG pulled to V_{OUT} through 5-k Ω resistor			1	μA
WATCHDOG ENABLE INPUT (nWD_EN PIN)						
V_{IL}	Logic input low level				0.8	V
V_{IH}	Logic input high level	$3\text{ V} < V_{DD} < 5.25\text{ V}$	2.5			V
WATCHDOG INPUT PULSE (WD PIN)						
V_{IL}	Logic input low level				0.8	V
V_{IH}	Logic input high level	$3\text{ V} < V_{DD} < 5.25\text{ V}$	2.5			V
t_{WD}	Watchdog window duration	$R_{OSC} = 10\text{ k}\Omega \pm 1\%$		10		ms
		$R_{OSC} = 20\text{ k}\Omega \pm 1\%$		20		
t_{WD-tol}	Tolerance of watchdog period using external resistor	Excludes tolerance of R_{OSC} (external resistor connected to ROSC pin)	-10%		10%	
$t_{WD-DEFAULT}$	Default watchdog period	External resistor not connected, ROSC pin is floating or open	108	164	254	ms
$t_{WD-HOLD}$	Minimum pulse width for resetting watch dog timer			1.65		μs
OPERATING TEMPERATURE RANGE						
T_J	Operating junction temperature		-40		150	$^{\circ}\text{C}$
$T_{SHUTDOWN}$	Thermal shutdown trip point			165		$^{\circ}\text{C}$
T_{HYST}	Thermal shutdown hysteresis			10		$^{\circ}\text{C}$

6.6 Typical Characteristics

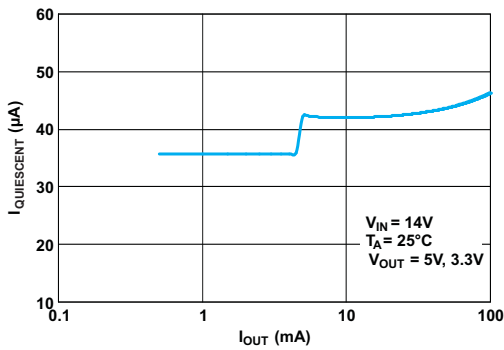

Figure 1. Quiescent Current vs Load Current

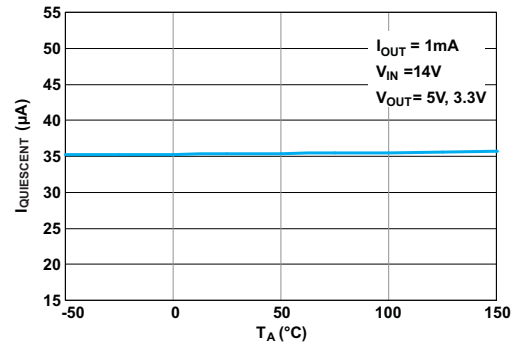

Figure 2. Quiescent Current vs Ambient Air Temperature

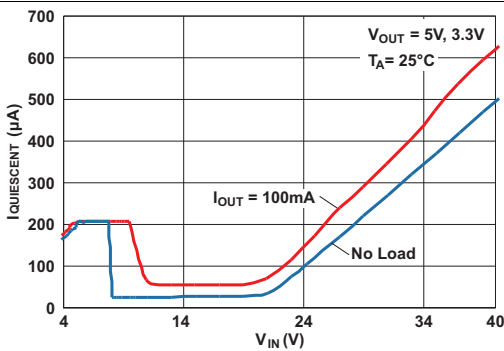
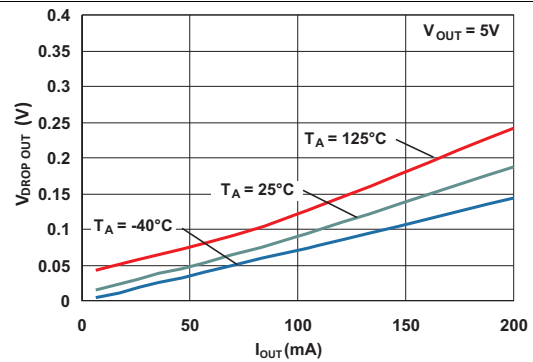

Figure 3. Quiescent Current vs Input Voltage



Measure dropout voltage when the output voltage drops by 100 mV from the regulated output-voltage level. (For example, for an output voltage programmed to be 5 V, measure the dropout voltage when the output voltage drops down to 4.9 V from 5 V.)

Figure 4. Dropout Voltage vs Load Current

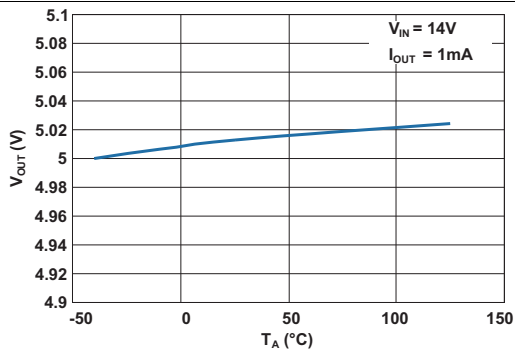

Figure 5. Output Voltage vs Ambient Air Temperature (V_{OUT} Set To 5 V)

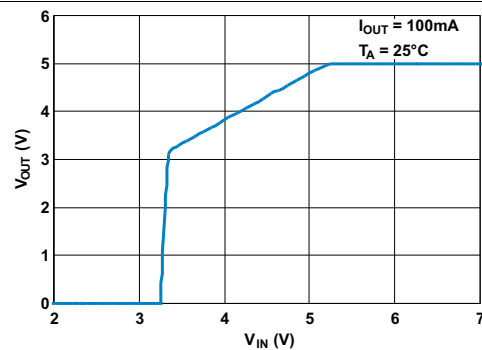

Figure 6. Output Voltage vs Input Voltage (V_{OUT} Set To 5 V)

Typical Characteristics (continued)

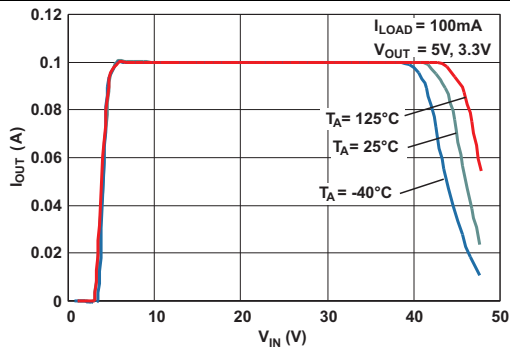

Figure 7. Output Voltage vs Input Voltage

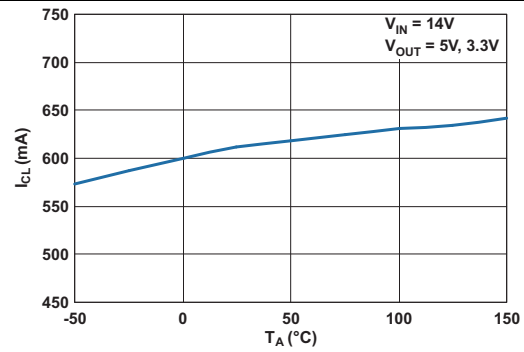

Figure 8. Output Current Limit vs Ambient Air Temperature

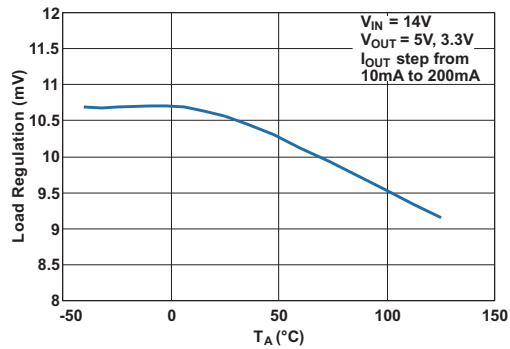

Figure 9. Load Regulation vs Ambient Air Temperature

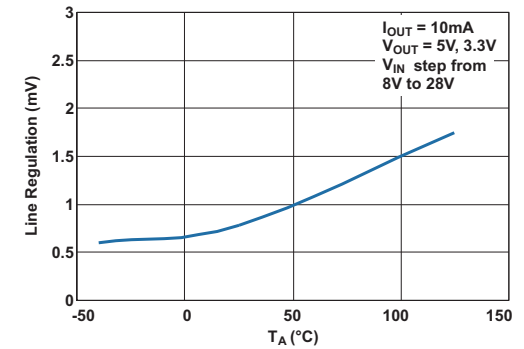

Figure 10. Line Regulation vs Ambient Air Temperature

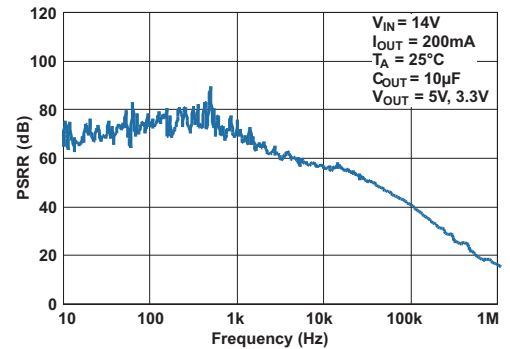

Figure 11. PSRR at Heavy Load Current

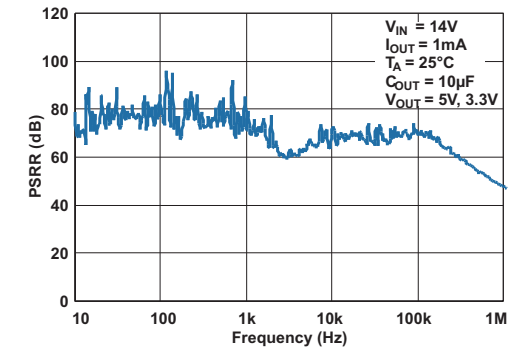

Figure 12. PSRR at Light Load Current

7 Detailed Description

7.1 Overview

The TPS7A63-Q1 and TPS7A6401-Q1 are a family of monolithic low-dropout linear voltage regulators with integrated watchdog and reset functionality. These voltage regulators are designed for low power consumption and quiescent current less than 25 μA in light-load applications. Because of a programmable reset delay (also called power-on-reset delay), these devices are well-suited in power supplies for microprocessors and microcontrollers.

These devices are available in two fixed and adjustable output-voltage versions as follows:

- Fault (WD_FLT) output version: TPS7A63-Q1
- Flag (WD_FLAG) output version: TPS7A6401-Q1

[Feature Description](#) describes the features of the TPS7A63-Q1 and TPS7A6401-Q1 voltage regulators in detail.

7.2 Functional Block Diagrams

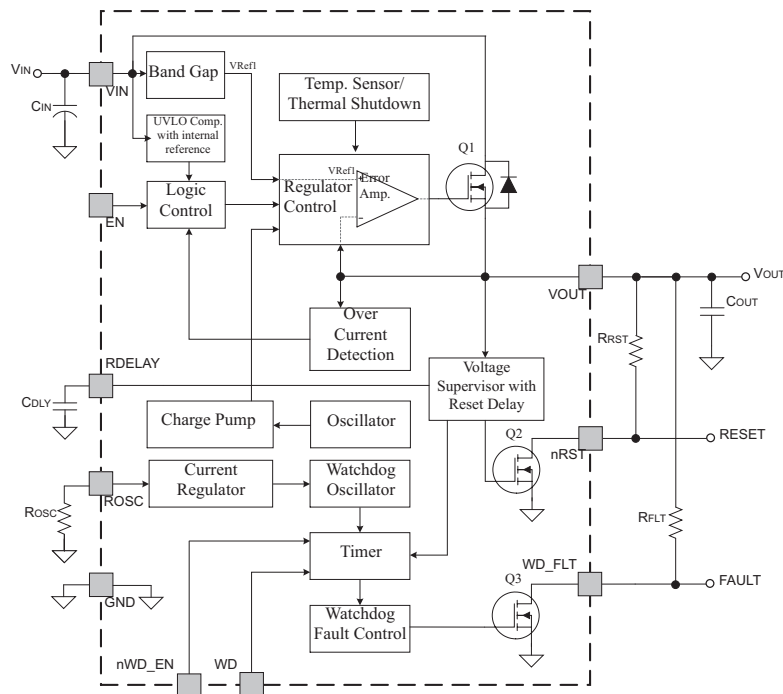

Figure 13. TPS7A6333-Q1 and TPS7A6350-Q1 (Fixed Output Voltage With Fault Output)

Functional Block Diagrams (continued)

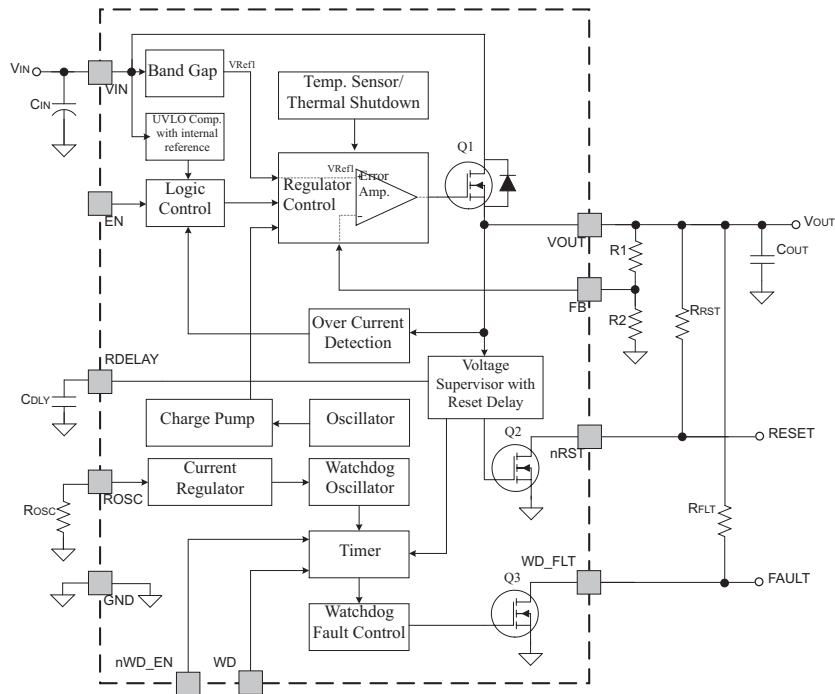

Figure 14. TPS7A6301 (Adjustable Output Voltage With Fault Output)

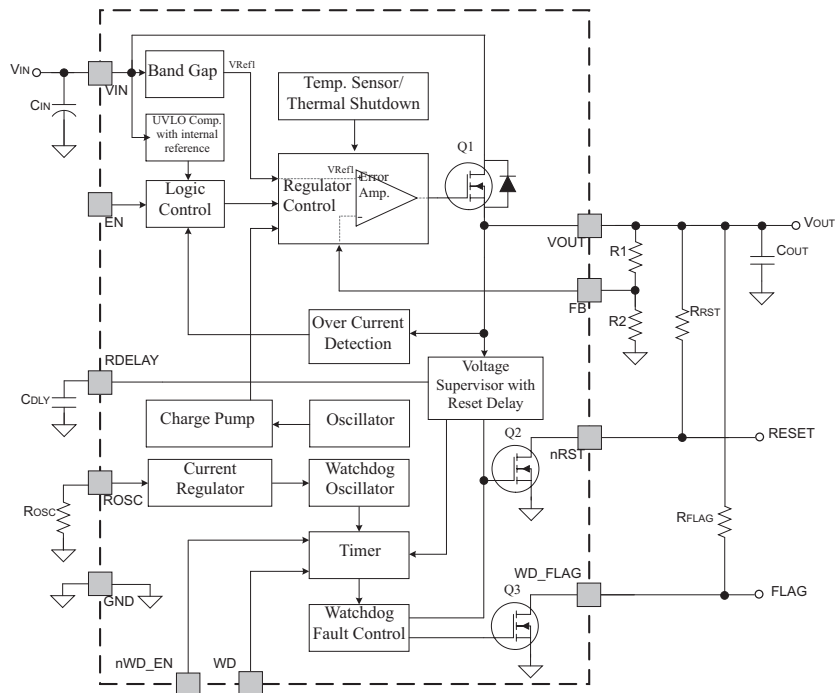

Figure 15. TPS7A6401-Q1 (Adjustable Output Voltage With Flag Output)

7.3 Feature Description

7.3.1 Power Up, Reset Delay, and Reset Output

During power up, the regulator incorporates a protection scheme to limit the current through the pass element and output capacitor. When the input voltage exceeds a certain threshold ($V_{IN(POWERUP)}$) level, the output voltage begins to ramp up as shown in [Figure 16](#).

When starting up, and also when the output recovers from a negative voltage spike due to a load step or a dip in the input voltage for a specified duration, the device implements reset delay to indicate that output voltage is stable and in regulation.

When the output voltage reaches the power-on-reset threshold ($V_{TH(POR)}$) level, that is, 93% of regulated output voltage (3.3 V or 5 V, or a programmed value), a constant output current charges an external capacitor (C_{DLY}) to an internal threshold ($V_{TH(RDELAY)}$) voltage level. Then, nRST asserts high and C_{DLY} discharges through an internal load. This allows C_{DLY} to charge from approximately 0 V during the next power cycle.

Program the reset delay time by connecting an external capacitor (C_{DLY} , 100 pF to 100 nF) to the RDELAY pin. [Equation 1](#) gives the delay time:

$$t_{POR} = \frac{C_{DLY} \times 3}{1 \times 10^{-6}}$$

where

- t_{POR} = reset delay time in seconds
- C_{DLY} = reset delay capacitor value in farads

(1)

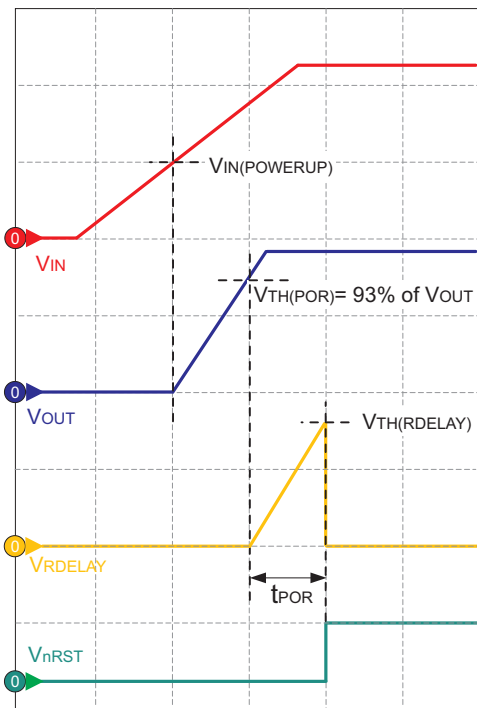

Figure 16. Power Up and Conditions for Activation of Reset

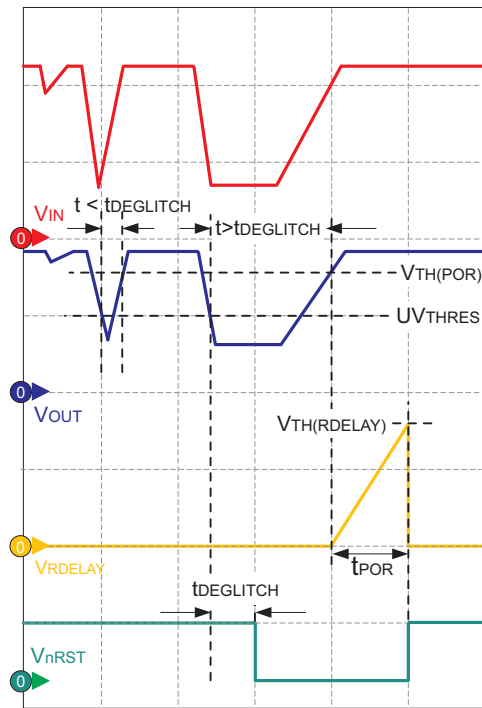

Figure 17. Reset Delay and Deglitch Filter

As [Figure 17](#) shows, if the regulated output voltage falls below 93% of the set level, nRST asserts low after a short de-glitch time of approximately 5.5 μ s (typical). In case of negative transients in the input voltage (V_{IN}), the reset signal asserts low only if the output (V_{OUT}) drops and stays below the reset threshold level ($V_{TH(POR)}$) for more than the deglitch time ($t_{DEGLITCH}$), as [Figure 17](#) and [Figure 20](#) illustrate. While nRST is low, if the input voltage returns to the nominal operating voltage, the normal power-up sequence ensues. nRST asserts high only if the output voltage exceeds the reset threshold voltage ($V_{TH(POR)}$) and the reset delay time (t_{POR}) has elapsed.

Feature Description (continued)

7.3.2 Adjustable Output Voltage

Program the regulated output voltage (V_{OUT}) by connecting external resistors to FB pin. Calculate the feedback resistor values using Equation 2.

$$V_{OUT} = V_{REF} \left[1 + \frac{R1}{R2} \right]$$

where

- V_{OUT} = desired output voltage
- V_{REF} = reference voltage ($V_{REF} = 1.23$ V, typically)
- R1, R2 = feedback resistors (see Figure 15)

Equation 3 gives the overall tolerance of the regulated output.

$$tol_{V_{OUT}} = tol_{V_{REF}} + \left[\frac{R1}{R1 + R2} \right] [tol_{R1} + tol_{R2}]$$

where

- $tol_{V_{OUT}}$ = tolerance of the output voltage
- $tol_{V_{REF}}$ = tolerance of the internal reference voltage ($tol_{V_{REF}} = \pm 1.5\%$ typically)
- tol_{R1}, tol_{R2} = tolerance of feedback resistors R1, R2

For a tighter tolerance on V_{OUT} , select lower-value feedback resistors. TI recommends to select feedback resistors such that the sum of R1 and R2 is from 20 k Ω to 200 k Ω .

7.3.3 Chip Enable

These devices have a high-voltage-tolerant EN pin that an external microcontroller or a digital control circuit can use to enable and disable them. A high input to this pin activates the device and turns the regulator on. For self bias applications, connect this input to the VIN terminal. An internal pulldown resistor is connected to this pin, and therefore if this pin remains unconnected, the device stays disabled.

7.3.4 Charge Pump Operation

These devices have an internal charge pump which turns on or off depending on the input voltage and the output current. The charge pump switching circuitry must not cause conducted emissions to exceed required thresholds on the input voltage line. For a given output current, the charge pump stays on at lower input voltages and turns off at higher input voltages. The charge pump switching thresholds are hysteretic. Figure 18 and Figure 19 show typical switching thresholds for the charge pump at light ($I_{OUT} < \text{approximately } 2$ mA) and heavy ($I_{OUT} > \text{approximately } 2$ mA) loads, respectively.

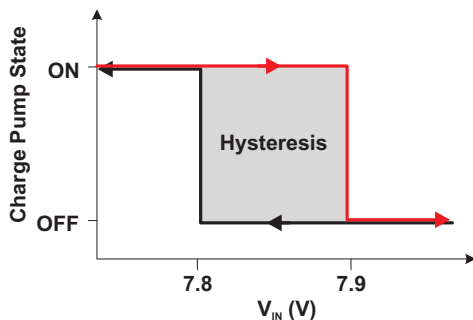

Figure 18. Charge Pump Operation at Light Loads

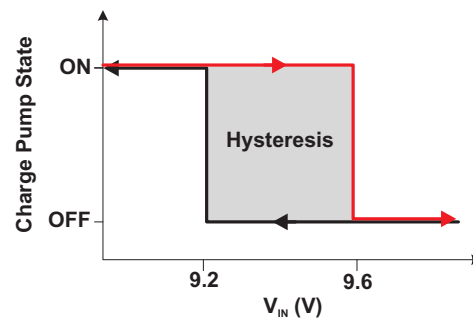

Figure 19. Charge Pump Operation at Heavy Loads

7.3.5 Low-Power Mode

At light loads and high input voltages ($V_{IN} >$ approximately 8 V, such that the charge pump is off), the device operates in low-power mode and the quiescent current consumption is reduced to 25 μ A (typical) as shown in [Table 1](#).

Table 1. Typical Quiescent Current Consumption

I_{OUT}	Charge Pump ON	Charge Pump OFF
$I_{OUT} <$ approximately 2 mA (Light load)	250 μ A	35 μ A (Low-power mode)
$I_{OUT} >$ approximately 2 mA (Heavy load)	280 μ A	70 μ A

7.3.6 Undervoltage Shutdown

These devices have an integrated undervoltage lockout (UVLO) circuit to shut down the output if the input voltage (V_{IN}) falls below an internally fixed UVLO threshold level ($V_{IN-UVLO}$). This ensures that the regulator does not latch into an unknown state during low input voltage conditions. The regulator powers up when the input voltage exceeds the $V_{IN(POWERUP)}$ level, as [Figure 20](#) shows.

7.3.7 Low-Voltage Tracking

At low input voltages, the regulator drops out of regulation, and the output voltage tracks the input minus a voltage based on the load current (I_{OUT}) and switch resistance (R_{SW}), as [Figure 20](#) shows. This feature allows for a smaller input capacitor and can possibly eliminate the need of using a boost converter during cold crank conditions, as [Figure 20](#) shows.

7.3.8 Integrated Fault Protection

These devices feature integrated fault protection to make them ideal for use in automotive applications. In order to remain in a safe area of operation during certain fault conditions, the devices use internal current-limit protection and current-limit foldback to limit the maximum output current. This protects them from excessive power dissipation. For example, during a short-circuit condition on the output, fault protection limits the current through the pass element to I_{CL} to protect the device from excessive power dissipation.

7.3.9 Thermal Shutdown

These devices incorporate a thermal shutdown (TSD) circuit as a protection from overheating. For continuous normal operation, the junction temperature should not exceed the TSD trip point. The junction temperature exceeding the TSD trip point causes the output to turn off. When the junction temperature falls below TSD trip point, the output turns on again, as [Figure 21](#) shows.

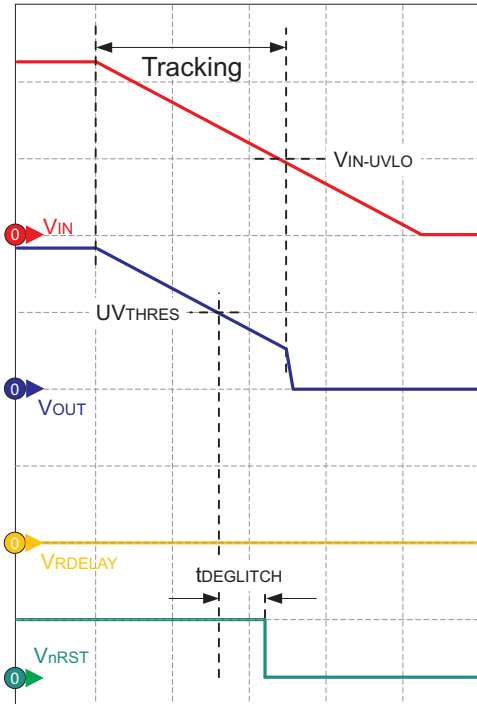

Figure 20. Low-Voltage Tracking and Undervoltage Lockout

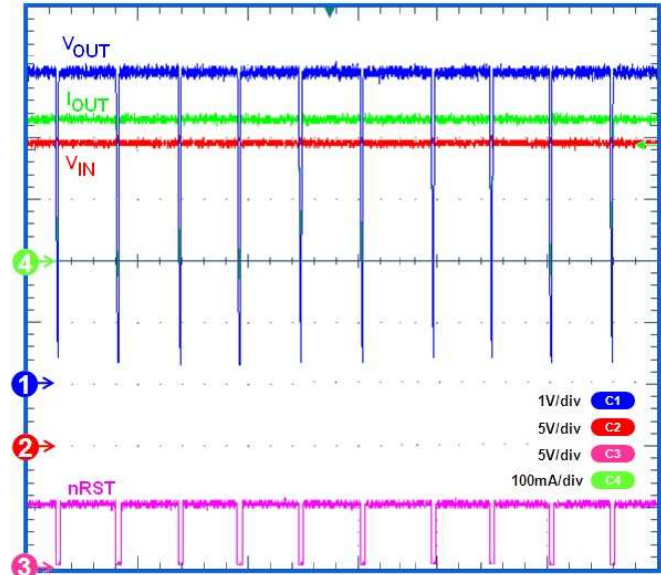

Figure 21. Thermal Cycling Waveform for TPS7A6350-Q1 ($V_{IN}= 24\text{ V}$, $I_{OUT}= 200\text{ mA}$, $V_{OUT}= 5\text{ V}$)

7.3.10 Integrated Window Watchdog

These devices have an integrated watchdog with fault (WD_FLT) and flag (WD_FLAG) output options. Both device options are available in fixed- and adjustable-output versions. The watchdog operation, service fault conditions, and difference between fault (TPS7A63-Q1) and flag (TPS7A6401-Q1) output versions are described as follows.

7.3.10.1 Programmable-Window Watchdog

Program the duration of the watchdog window by connecting an external resistor (R_{OSC}) to ground at the ROSC pin. The current through the resistor sets the clock frequency of the internal oscillator. The user can adjust the duration of the watchdog window (that is, the watchdog timer period) by changing the resistor value. The duration of the watchdog window and the duration of the fault output are multiples of the internal oscillator frequency and are given by the following equations:

$$t_{WD} = 10^{-6} \times R_{OSC} = 5000 \times 1 / f_{OSC} \quad (4)$$

$$t_{WD_OUT} = 1 / f_{OSC} \quad (5)$$

$$t_{CW} = t_{OW} = 1 / 2 t_{WD}$$

where

- t_{WD} = width of watchdog window
 - R_{OSC} = resistor connected at ROSC pin
 - t_{WD_OUT} = duration of fault output
 - f_{OSC} = frequency of internal oscillator
 - t_{CW} = duration of closed window
 - t_{OW} = duration of open window
- (6)

As shown in Figure 22, each watchdog window consists of an open window and a closed window, each having a width approximately 50% of the watchdog window. However, there is an exception to this; the first open window after watchdog initialization is eight times the duration of the watchdog window. All open windows except the one after watchdog initialization are one-half the width of the watchdog window. On initialization, the watchdog must receive service (by software, external microcontroller, and so forth) only during an open window. A watchdog serviced during a closed window, or not serviced during a open window, creates a watchdog fault condition.

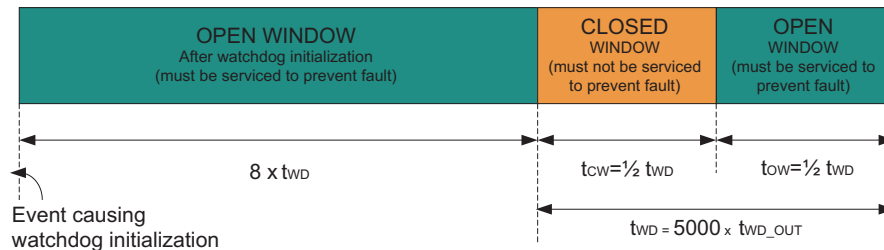
Figure 22. Watchdog Window Duration

7.3.10.2 Watchdog Enable

An external microcontroller or a digital circuit can apply an appropriate signal to the nWD_EN pin to enable or disable the watchdog. A low input to this pin turns the watchdog on. Because of an internal pulldown resistor connected to this pin, leaving the pin unconnected keeps the watchdog enabled.

7.3.10.3 Watchdog Service Signal

In order for the watchdog service signal (WD) to service an open window correctly, the service signal must stay high for a duration of at least t_{WD_HOLD} . The recommended value of t_{WD_HOLD} is given by [Equation 7](#):

$$t_{WD_HOLD} = 3 \times t_{WD_OUT} \quad (7)$$



7.3.10.4 Watchdog Fault Outputs

The WD_FLT pin and WD_FLAG pin are fault output terminals for the TPS7A63-Q1 and TPS7A6401-Q1 devices, respectively. Typically, one pulls these fault outputs high to a regulated output supply. In the case of a watchdog fault condition, the TPS7A63-Q1 momentarily pulls WD_FLT low for a duration of t_{WD_OUT} , whereas the TPS7A6401-Q1 latches the WD_FLAG high and momentarily pulls nRST low for a duration of t_{WD_OUT} .

7.3.10.5 Watchdog Initialization

On power up and during normal operation, the watchdog initializes under the conditions shown in [Table 2](#). The normal operation of the watchdog for the WD_FLT and WD_FLAG output device options is shown in [Figure 23](#) and [Figure 24](#), respectively.

Table 2. Conditions For Watchdog Initialization

Edge	What causes watchdog to initialize?	TPS7A63-Q1 (FAULT Option)	TPS7A6401-Q1 (FLAG Option)
	Rising edge of nRST (when V_{OUT} exceeds $V_{TH(POR)}$) while the watchdog is in the enabled state, for example, during soft power up	✓	✓
	Falling edge of nWD_EN while the nRST is already high, for example, when the microprocessor enables the watchdog after the device is powered up	✓	✓
	Rising edge of WD_FLT while the nRST is already high and the watchdog is in the enabled state, for example, right after a closed window is serviced	✓	X

7.3.10.6 Watchdog Operation

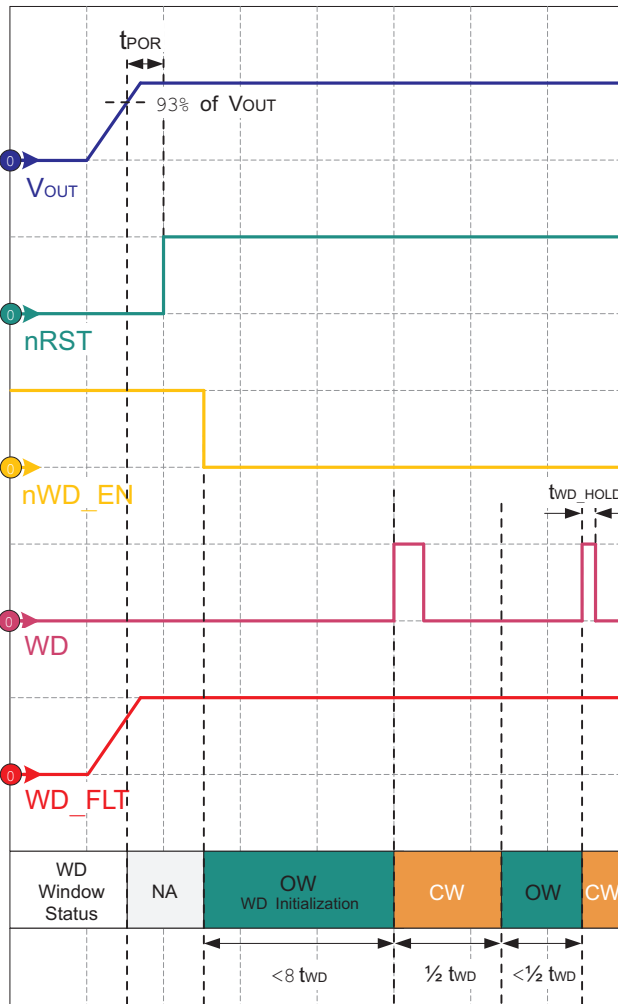

Figure 23. Power Up, Initialization, and Normal Operation for TPS7A63-Q1

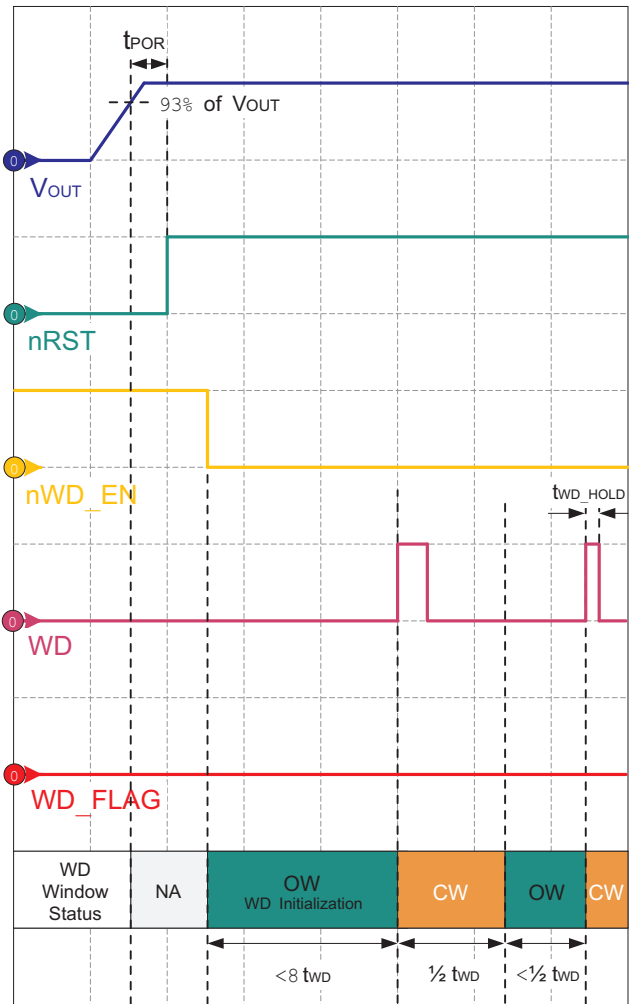

Figure 24. Power Up, Initialization, and Normal Operation for TPS7A6401-Q1

Figure 23 shows watchdog initialization and operation for the TPS7A63-Q1. After output voltage is in regulation and reset asserts high (clearly the chip-enable pin is high), the watchdog becomes enabled when an external signal pulls nWD_EN (the watchdog enable pin) low. This causes the watchdog to initialize and wait for a service signal during the first open window for 8x the duration of t_{WD}. A service signal applied to the WD pin during the first open window resets the watchdog counter and a closed window starts. To prevent a fault condition from occurring, watchdog service must not occur during the closed window. Watchdog service must occur during the following open window to prevent fault condition from occurring. The fault output (WD_FLT), externally pulled up to VOUT (typically), stays high as long as the watchdog receives proper serviced and there is no fault condition.

Figure 24 shows watchdog initialization and operation for FLAG output version (TPS7A6401-Q1). The fault output (WD_FLAG), externally pulled up to VOUT (typically), stays low as long as the watchdog receives proper service and there is no fault condition.

Likewise, enabling the watchdog before powering the device on (that is, pulling the nWD_EN pin low before power up), the watchdog initializes as soon as the output voltage is in regulation and reset asserts high (see Table 2 for Conditions for Watchdog Initialization).

7.3.10.7 Watchdog Fault Conditions

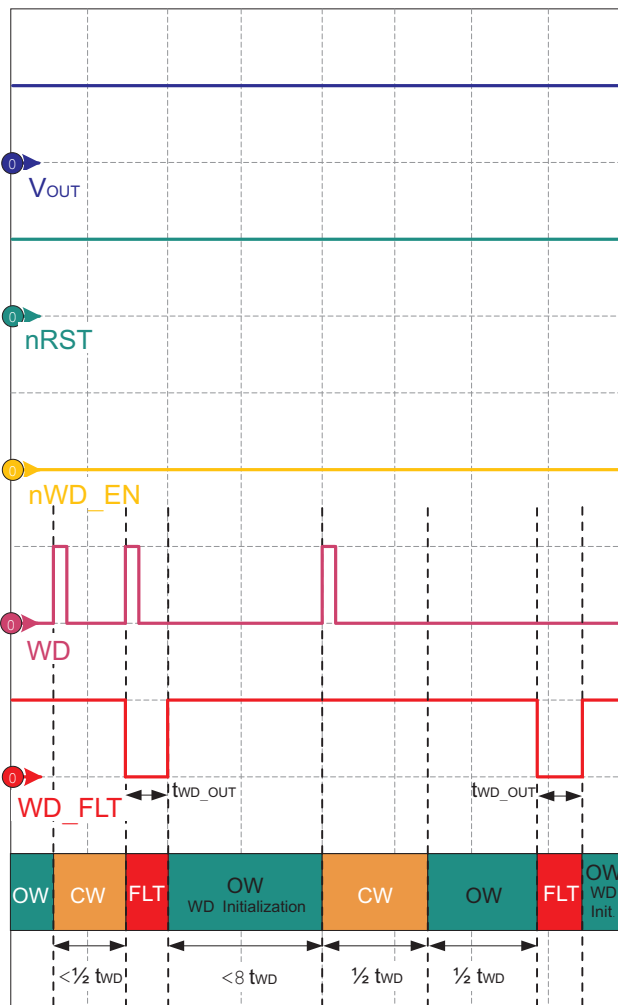

Figure 25. Watchdog Service Fault Conditions for TPS7A63-Q1

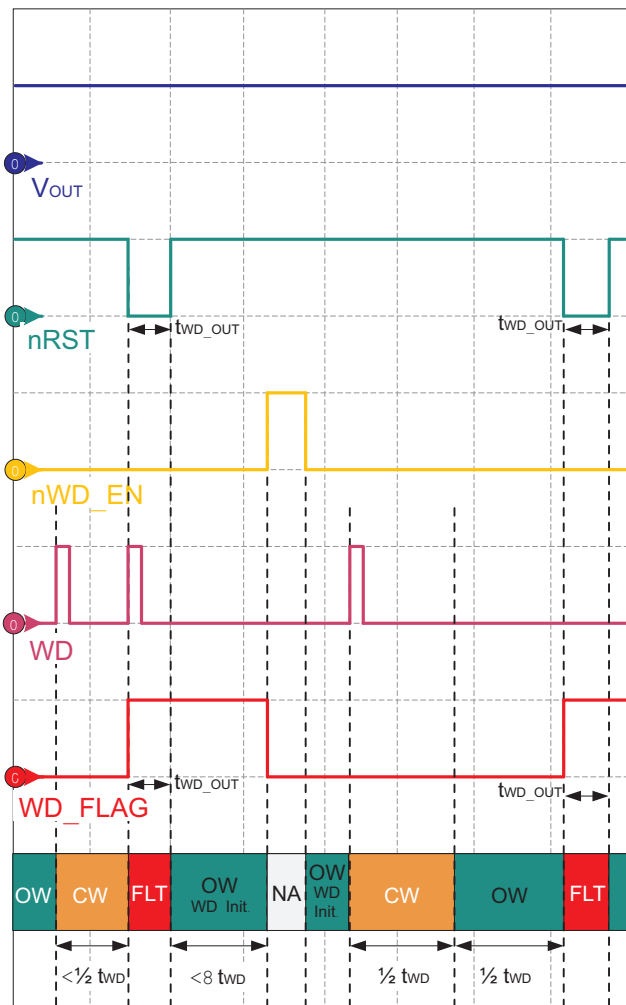

Figure 26. Watchdog Service Fault Conditions for TPS7A6401-Q1

For both device options, a watchdog fault condition occurs in following (non-exhaustive) cases:

- When the watchdog receives service during a closed window.
- When watchdog does not receive service during an open window (this open window could be the one after watchdog initialization, or the one following a closed window).

As shown in [Figure 25](#), for TPS7A63-Q1 the first watchdog fault registers when the watchdog receives service during a closed window. This causes the watchdog fault pin (WD_FLT) to go low temporarily for a duration of t_{WD_OUT} . Following the fault, the watchdog reinitializes. Likewise, the second fault registers when the watchdog does not receive service during an open window (following a closed window). Again, the fault pin (WD_FLT) asserts low for a duration of t_{WD_OUT} .

As shown in [Figure 26](#), for TPS7A6401-Q1 the first watchdog fault registers when watchdog receives service during a closes window. This causes the watchdog flag pin (WD_FLAG) to become high and stay latched. At the same time, nRST pin goes low temporarily for the duration of t_{WD_OUT} . WD_FLAG remains high until toggling the nWD_EN pin disables and re-enables the watchdog or the watchdog receives service properly (while nWD_EN is low and nRST is high). The second fault registers when the watchdog does not receive service during an open window (following a closed window). While WD_FLAG is high (that is, during a fault condition), if the watchdog stays enabled, and reset is high; a watchdog service signal can also bring WD_FLAG low (about 5 μ s after the watchdog receives service).

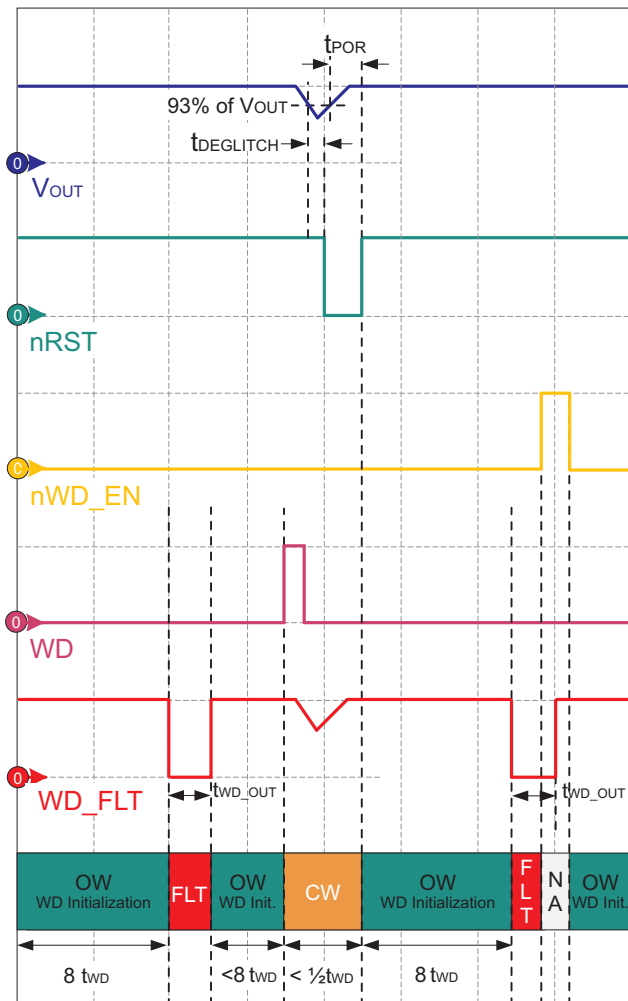

Figure 27. Watchdog Fault During Initialization, and Reinitialization During Reset for TPS7A63-Q1

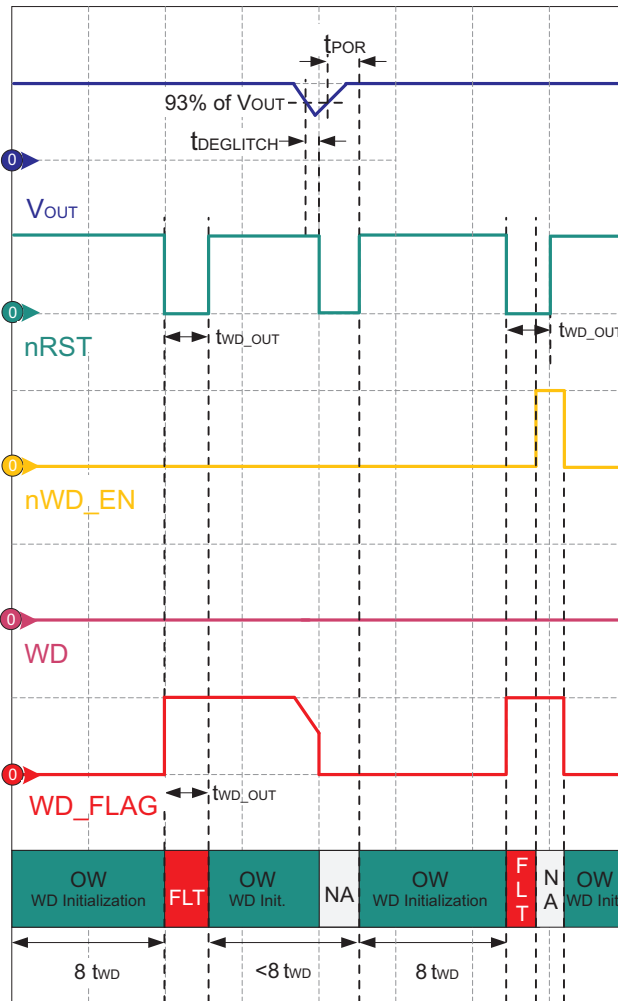

Figure 28. Watchdog Fault During Initialization, and Reinitialization During Reset for TPS7A6401-Q1

As shown in Figure 27 for the TPS7A6401-Q1, the watchdog fault condition also occurs if the watchdog does not receive service during the open window after watchdog initialization. That is, if the watchdog does not receive service during the first $8 \times t_{WD_OUT}$ period after initialization, a fault condition occurs. This causes the watchdog fault pin (WD_FLT) to go low temporarily for a duration of t_{WD_OUT} . In case of a load transient, if the regulated output voltage drops down causing reset (nRST) to go low, the rising edge on nRST causes the watchdog to reinitialize (that is, when reset becomes high with the watchdog still enabled). During a fault condition (that is, WD_FLT is low) with the watchdog disabled, the fault output continues to stay low until t_{WD_OUT} is elapsed. A falling edge on nWD_EN pin causes the watchdog to reinitialize while nRST is still high.

As shown in Figure 28 for the TPS7A6401-Q1, the watchdog fault condition also occurs if the watchdog does not receive service during the open window after watchdog initialization. That is, if the watchdog does not receive service in first $8 \times t_{WD_OUT}$ period after initialization, a fault condition occurs. This causes the watchdog flag pin (WD_FLAG) to become high and stay latched. At the same time, the nRST pin goes low temporarily for a duration of t_{WD_OUT} . In the case of a load transient, if the regulated output voltage drops down causing the reset output to go low, the WD_FLAG asserts low, and the rising edge on nRST causes the watchdog to reinitialize (while the watchdog remains enabled). During a fault condition (that is, WD_FLAG is high), and with a disabled watchdog, the flag output continues to stay high as long as the watchdog remains enabled or receives proper service. However, nRST stays low until t_{WD_OUT} elapses. Re-enabling the watchdog causes watchdog to reinitialize (while nRST is still high).

7.4 Device Functional Modes

7.4.1 Operation With V_{IN} Lower Than 4 V

The TPS7A63-Q1 and TPS7A6401-Q1 family devices operate with input voltage above 4 V. The typical UVLO voltage is 3.16 V. The device can operate at input voltage lower than 4 V, but at input voltage below the actual UVLO, the device will shut down.

7.4.2 Operation With V_{IN} Larger Than 4 V

When V_{IN} is greater than 4 V, if the input voltage is higher than V_{OUT} plus the dropout voltage, the output voltage is equal to the set value. Otherwise, the output voltage is equal to V_{IN} minus the dropout voltage.

8 Application and Implementation

NOTE

Information in the following applications sections is not part of the TI component specification, and TI does not warrant its accuracy or completeness. TI's customers are responsible for determining suitability of components for their purposes. Customers should validate and test their design implementation to confirm system functionality.

8.1 Application Information

Typical application circuits for TPS76333-Q1/TPS76350-Q1 and TPS7A6401-Q1 are shown in [Figure 29](#) and [Figure 32](#). Depending on the end application, one may use different values of external components. Carefully select feedback resistors (R1 and R2), used to program the output voltage. Using smaller resistors results in higher current consumption, whereas using very large resistors impacts the sensitivity of the regulator. Therefore, TI recommends selecting feedback resistors such that the sum of R1 and R2 is from 20 k Ω to 200 k Ω .

8.1.1 Example

If the desired regulated output voltage is 5 V, after selecting R2 then one can calculate R1 using (or vice versa) [Equation 2](#). Knowing $V_{REF} = 1.23$ V (typical), $V_{OUT} = 5$ V, selecting R2 = 20 k Ω , the calculated value of R1 is 61.3 k Ω .

During fast load steps, an application may require a larger output capacitor to prevent the output from temporarily dropping down. TI recommends a low-ESR ceramic capacitor with dielectric of type X5R or X7R. One can also connect a bypass capacitor at the output to decouple high-frequency noise as per the end application.

8.2 Typical Applications

8.2.1 Typical Application Using the TPS7A6333-Q1 or TPS7A6350-Q1

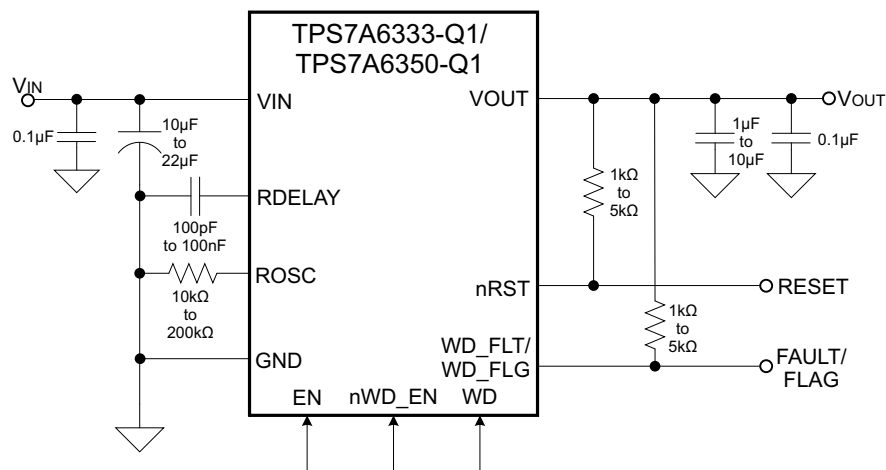

Figure 29. Typical Application Schematic, TPS7A6333-Q1/6350-Q1

Typical Applications (continued)

8.2.1.1 Design Requirements

For this design example, use the parameters listed in [Table 3](#).

Table 3. Design Parameters

DESIGN PARAMETER	EXAMPLE VALUES
Input voltage range	11 V - 40 V
Input capacitor range	10 μ F - 22 μ F
Output voltage	3.3 V, 5 V
Output current rating	300 mA maximum
Output capacitor range	1 μ F-10 μ F

8.2.1.2 Detailed Design Procedure

When using the TPS7A6333-Q1, TPS7A6350-Q1, TI recommends adding a 10- μ F to 22- μ F capacitor to the input to keep the input voltage stable. TI also recommends adding a 1- μ F to 10- μ F low ESR ceramic capacitor to get a stable output.

The reset delay time is set by an external capacitor (CDLY) to ground, capacitor value typical from 100 pF to 100 nF. [Equation 1](#) provides the method for the calculation.

Connecting an external resistor to ground at the ROSC pin can set the duration of the watchdog window. [Equation 4](#) provides the method for the calculation. Usually a 10-k Ω to 200-k Ω resistor can be used to set the time.

8.2.1.3 Application Curves

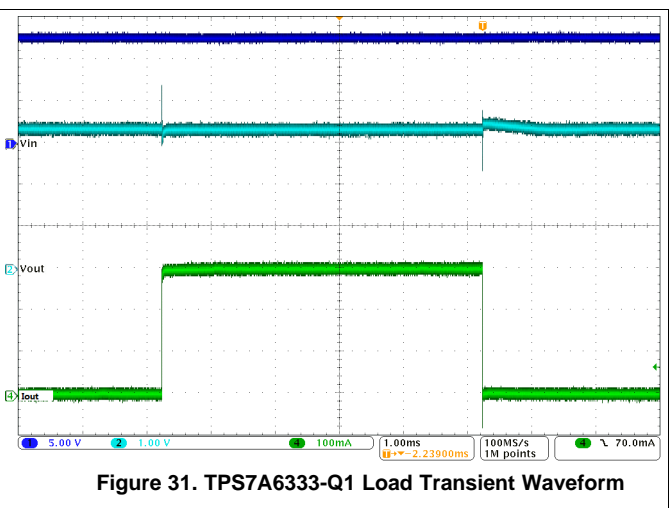
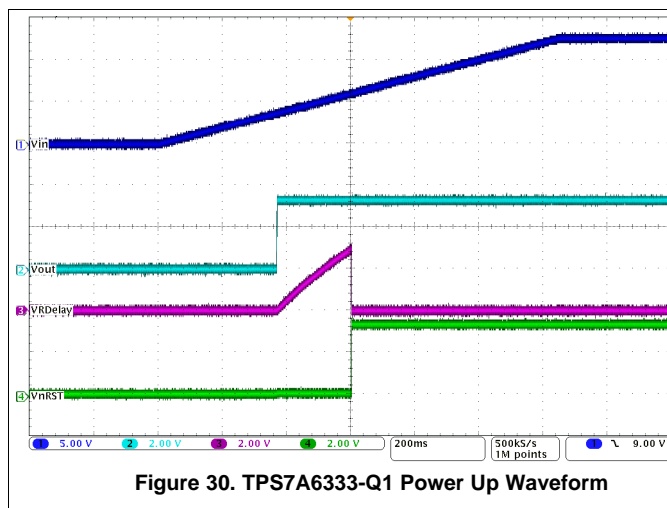

8.2.2 Typical Application Using the TPS7A6401-Q1

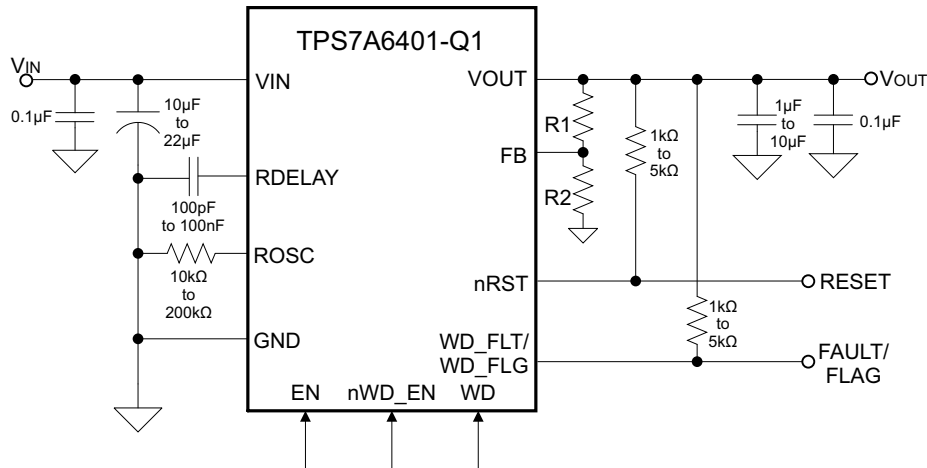

Figure 32. Typical Application Schematic TPS7A6401-Q1

8.2.2.1 Design Requirements

For this design example, use the parameters listed in [Table 4](#).

Table 4. Design Parameters

DESIGN PARAMETER	EXAMPLE VALUES
Input voltage range	11 V - 40 V
Input capacitor range	10 µF-22 µF
Output voltage	2.5 V - 7 V
Output current rating	300 mA maximum
Output capacitor range	1 µF-10 µF

8.2.2.2 Detailed Design Procedure

When using TPS7A6401-Q1, TI recommends adding a 10-µF to 22-µF capacitor to the input to keep the input voltage stable. TI also recommends adding a 1-µF to 10-µF low ESR ceramic capacitor to get a stable output.

The output voltage is set by the R1 and R2 resistor network. Output voltage can be calculated by [Equation 2](#).

The reset delay time is set by an external capacitor (CDLY) to ground, capacitor value typical from 100 pF to 100 nF. [Equation 1](#) provides the method for the calculation. Connecting an external resistor to ground at the ROSC pin can set the duration of the watchdog window. [Equation 4](#) provides the method for the calculation. Usually a 10-kΩ to 200-kΩ resistor can be used to set the time.

8.2.2.3 Application Curves

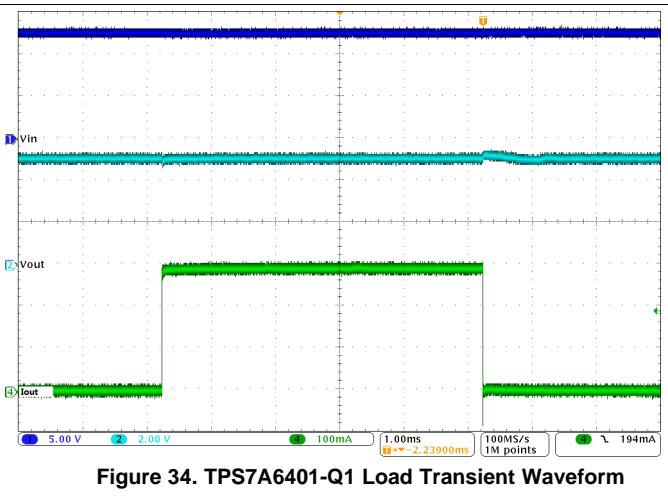
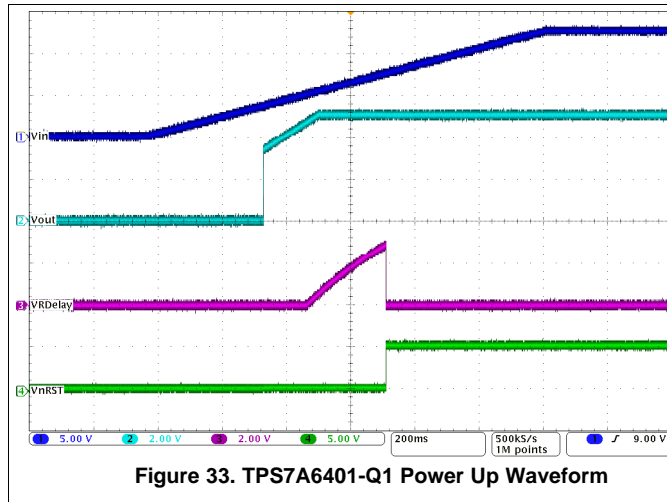

9 Power Supply Recommendations

The device is designed to operate from an input-voltage supply range from 11 V to 40 V. This input supply must be well regulated. If the input supply is located more than a few inches from the TPS7A63XX-Q1 or TPS7A64XX-Q1 device, TI recommends adding an electrolytic capacitor with a value of 10 μ F and a ceramic bypass capacitor at the input.

10 Layout

10.1 Layout Guidelines

For the LDO power supply, especially these high voltage and large current ones, layout is an important step. If layout is not carefully designed, the regulator could not deliver enough output current because of the thermal limitation. To improve the thermal performance of the device, and maximize the current output at high ambient temperature, it is recommended to spread the thermal pad as large as possible and put enough thermal vias on the thermal pad. [Figure 37](#) shows an example layout.

10.1.1 Power Dissipation and Thermal Considerations

Calculate the power dissipated in the device using [Equation 8](#).

$$P_D = I_{OUT} \times (V_{IN} - V_{OUT}) + I_{QUIESCENT} \times V_{IN}$$

where

- P_D = continuous power dissipation
- I_{OUT} = output current
- V_{IN} = input voltage
- V_{OUT} = output voltage
- $I_{QUIESCENT}$ = quiescent current

(8)

As $I_{QUIESCENT} \ll I_{OUT}$, therefore, ignore the term $I_{QUIESCENT} \times V_{IN}$ in [Equation 8](#).

For a device in operation at a given ambient air temperature (T_A), calculate the junction temperature (T_J) using [Equation 9](#).

$$T_J = T_A + (R_{\theta JA} \times P_D)$$

where

- $R_{\theta JA}$ = junction-to-ambient-air thermal impedance

(9)

Calculate the rise in junction temperature due to power dissipation using [Equation 10](#).

Layout Guidelines (continued)

$$\Delta T = T_J - T_A = (R_{\theta JA} \times P_D) \tag{10}$$

For a given maximum junction temperature (T_{J-Max}), calculate the maximum ambient air temperature (T_{A-Max}) at which the device can operate using [Equation 11](#).

$$T_{A-Max} = T_{J-Max} - (R_{\theta JA} \times P_D) \tag{11}$$

10.1.1.1 Example

If $I_{OUT} = 100\text{ mA}$, $V_{OUT} = 5\text{ V}$, $V_{IN} = 14\text{ V}$, $I_{QUIESCENT} = 250\text{ }\mu\text{A}$, and $R_{\theta JA} = 50^\circ\text{C/W}$, the continuous power dissipated in the device is 0.9 W. The rise in junction temperature due to power dissipation is 45°C. For a maximum junction temperature of 150°C, the maximum ambient air temperature at which the device can operate is 105°C.

For adequate heat dissipation, TI recommends soldering the thermal pad (exposed heat sink) to the thermal land pad on the PCB. Doing this provides a heat conduction path from the die to the PCB and reduces overall package thermal resistance. Power derating curves for the TPS7A63-Q1 and TPS7A6401-Q1 PWP package and TPS7A6333-Q1 DRK are comparable; see [Figure 35](#).

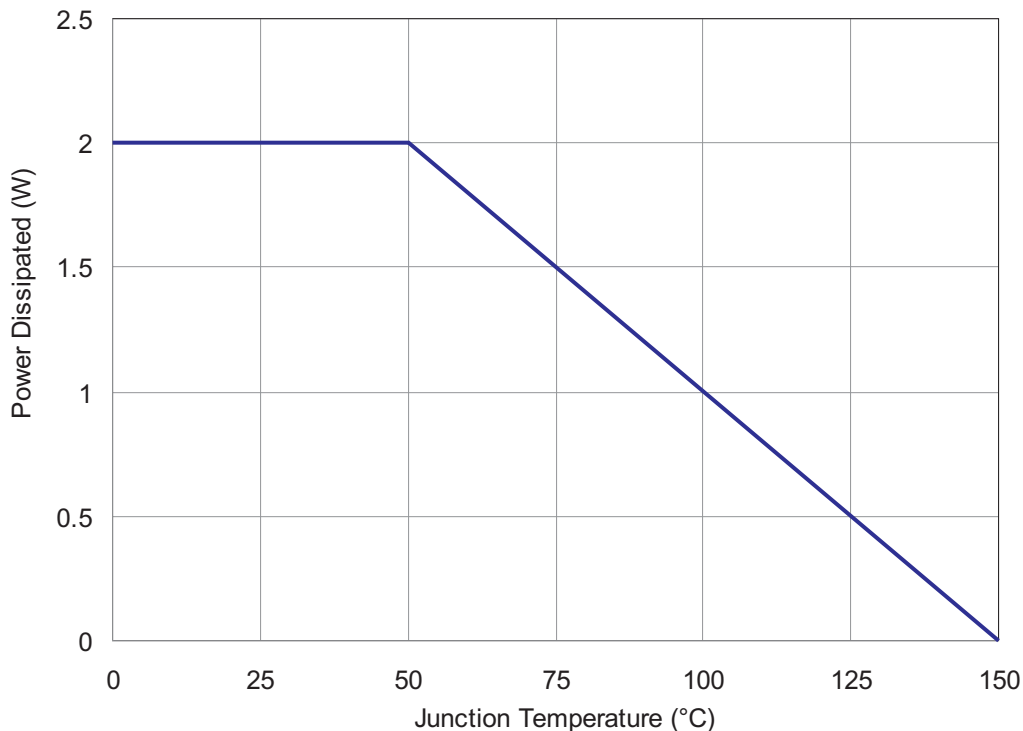
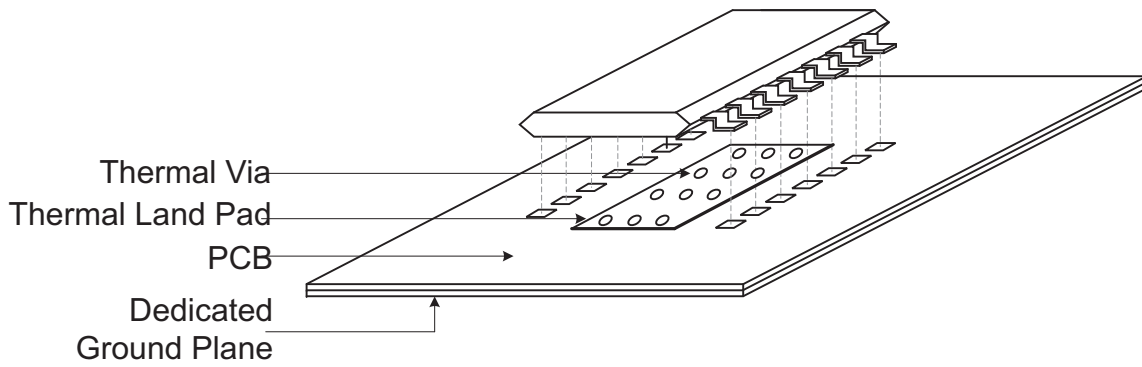

Figure 35. Power Derating Curve

For optimum thermal performance, TI recommends using a high-K PCB with thermal vias between the ground plane and solder pad or thermal land pad; see [Figure 36](#) (a) and (b). Further, use a thicker ground plane and a thermal land pad with a larger surface area to improve considerably the heat-spreading capabilities of a PCB. For a two-layer PCB, a bat wing layout can enhance the heat-spreading capabilities.

Layout Guidelines (continued)



(a) Multilayer PCB with a dedicated ground plane

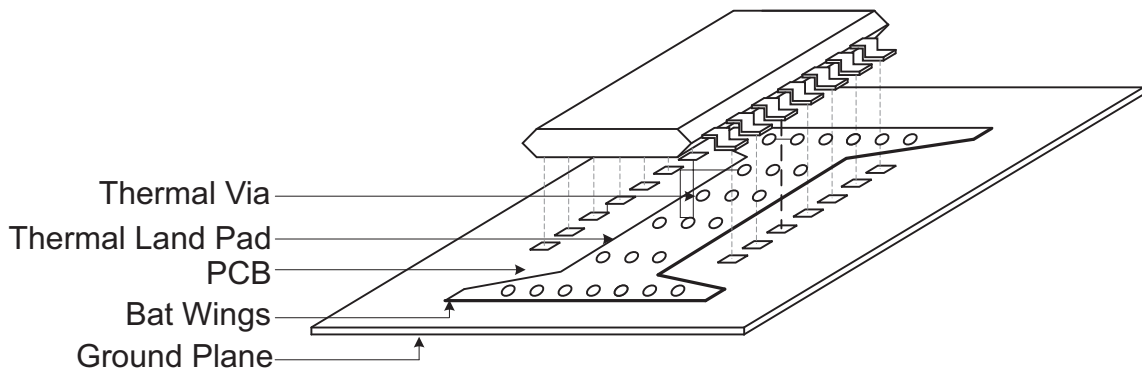

(b) Dual layer PCB with Bat wings for enhanced heat spreading

Figure 36. Using Multilayer PCB and Thermal Vias for Adequate Heat Dissipation

Keeping other factors constant, surface area of the thermal land pad contributes to heat dissipation only to a certain extent.

10.2 Layout Example

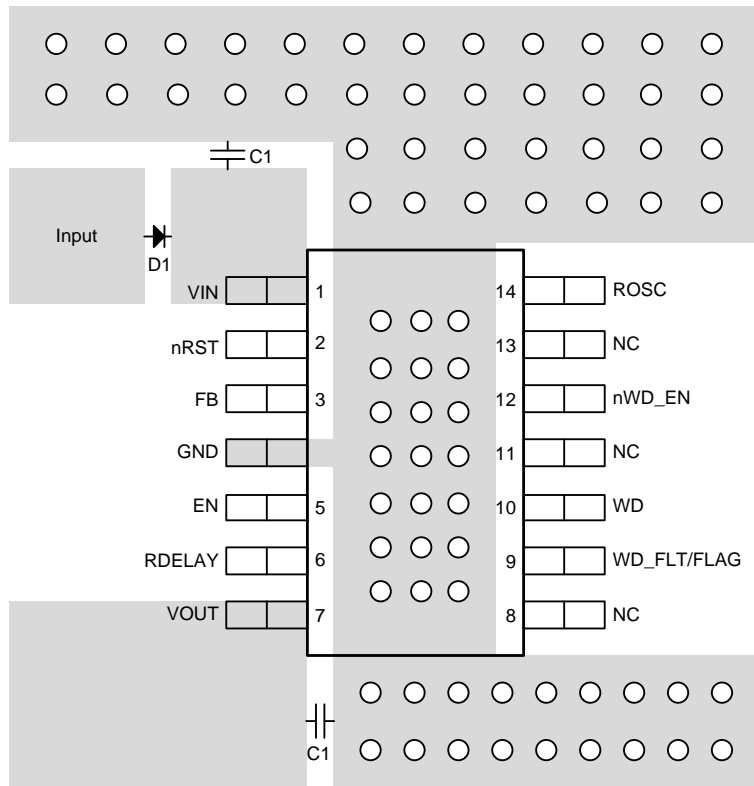

Figure 37. Layout Recommendation

11 Device and Documentation Support

11.1 Related Links

The table below lists quick access links. Categories include technical documents, support and community resources, tools and software, and quick access to order now.

Table 5. Related Links

PARTS	PRODUCT FOLDER	ORDER NOW	TECHNICAL DOCUMENTS	TOOLS & SOFTWARE	SUPPORT & COMMUNITY
TPS7A63-Q1	Click here	Click here	Click here	Click here	Click here
TPS7A6401-Q1	Click here	Click here	Click here	Click here	Click here

11.2 Receiving Notification of Documentation Updates

To receive notification of documentation updates, navigate to the device product folder on ti.com. In the upper right corner, click on *Alert me* to register and receive a weekly digest of any product information that has changed. For change details, review the revision history included in any revised document.

11.3 Community Resources

The following links connect to TI community resources. Linked contents are provided "AS IS" by the respective contributors. They do not constitute TI specifications and do not necessarily reflect TI's views; see TI's [Terms of Use](#).

TI E2E™ Online Community *TI's Engineer-to-Engineer (E2E) Community*. Created to foster collaboration among engineers. At e2e.ti.com, you can ask questions, share knowledge, explore ideas and help solve problems with fellow engineers.

Design Support *TI's Design Support* Quickly find helpful E2E forums along with design support tools and contact information for technical support.

11.4 Trademarks

E2E is a trademark of Texas Instruments.
All other trademarks are the property of their respective owners.

11.5 Electrostatic Discharge Caution



This integrated circuit can be damaged by ESD. Texas Instruments recommends that all integrated circuits be handled with appropriate precautions. Failure to observe proper handling and installation procedures can cause damage.

ESD damage can range from subtle performance degradation to complete device failure. Precision integrated circuits may be more susceptible to damage because very small parametric changes could cause the device not to meet its published specifications.

11.6 Glossary

[SLYZ022](#) — *TI Glossary*.

This glossary lists and explains terms, acronyms, and definitions.

12 Mechanical, Packaging, and Orderable Information

The following pages include mechanical, packaging, and orderable information. This information is the most current data available for the designated devices. This data is subject to change without notice and revision of this document. For browser-based versions of this data sheet, refer to the left-hand navigation.

PACKAGING INFORMATION

Orderable Device	Status (1)	Package Type	Package Drawing	Pins	Package Qty	Eco Plan (2)	Lead/Ball Finish (6)	MSL Peak Temp (3)	Op Temp (°C)	Device Marking (4/5)	Samples
TPS7A6301QPWPRQ1	ACTIVE	HTSSOP	PWP	14	2000	Green (RoHS & no Sb/Br)	CU NIPDAU	Level-3-260C-168 HR	-40 to 125	7A6301	Samples
TPS7A6333QDRKRQ1	ACTIVE	VSON	DRK	10	3000	Green (RoHS & no Sb/Br)	CU NIPDAU	Level-3-260C-168 HR	-40 to 125	PRGQ	Samples
TPS7A6333QPWPRQ1	ACTIVE	HTSSOP	PWP	14	2000	Green (RoHS & no Sb/Br)	CU NIPDAU	Level-3-260C-168 HR	-40 to 125	7A6333	Samples
TPS7A6350QPWPRQ1	ACTIVE	HTSSOP	PWP	14	2000	Green (RoHS & no Sb/Br)	CU NIPDAU	Level-3-260C-168 HR	-40 to 125	7A6350	Samples
TPS7A6401QPWPRQ1	ACTIVE	HTSSOP	PWP	14	2000	Green (RoHS & no Sb/Br)	CU NIPDAU	Level-3-260C-168 HR	-40 to 125	7A6401	Samples

(1) The marketing status values are defined as follows:

ACTIVE: Product device recommended for new designs.

LIFEBUY: TI has announced that the device will be discontinued, and a lifetime-buy period is in effect.

NRND: Not recommended for new designs. Device is in production to support existing customers, but TI does not recommend using this part in a new design.

PREVIEW: Device has been announced but is not in production. Samples may or may not be available.

OBSOLETE: TI has discontinued the production of the device.

(2) **RoHS:** TI defines "RoHS" to mean semiconductor products that are compliant with the current EU RoHS requirements for all 10 RoHS substances, including the requirement that RoHS substance do not exceed 0.1% by weight in homogeneous materials. Where designed to be soldered at high temperatures, "RoHS" products are suitable for use in specified lead-free processes. TI may reference these types of products as "Pb-Free".

RoHS Exempt: TI defines "RoHS Exempt" to mean products that contain lead but are compliant with EU RoHS pursuant to a specific EU RoHS exemption.

Green: TI defines "Green" to mean the content of Chlorine (Cl) and Bromine (Br) based flame retardants meet JS709B low halogen requirements of <=1000ppm threshold. Antimony trioxide based flame retardants must also meet the <=1000ppm threshold requirement.

(3) MSL, Peak Temp. - The Moisture Sensitivity Level rating according to the JEDEC industry standard classifications, and peak solder temperature.

(4) There may be additional marking, which relates to the logo, the lot trace code information, or the environmental category on the device.

(5) Multiple Device Markings will be inside parentheses. Only one Device Marking contained in parentheses and separated by a "-" will appear on a device. If a line is indented then it is a continuation of the previous line and the two combined represent the entire Device Marking for that device.

(6) Lead/Ball Finish - Orderable Devices may have multiple material finish options. Finish options are separated by a vertical ruled line. Lead/Ball Finish values may wrap to two lines if the finish value exceeds the maximum column width.

Important Information and Disclaimer: The information provided on this page represents TI's knowledge and belief as of the date that it is provided. TI bases its knowledge and belief on information provided by third parties, and makes no representation or warranty as to the accuracy of such information. Efforts are underway to better integrate information from third parties. TI has taken and continues to take reasonable steps to provide representative and accurate information but may not have conducted destructive testing or chemical analysis on incoming materials and chemicals. TI and TI suppliers consider certain information to be proprietary, and thus CAS numbers and other limited information may not be available for release.

In no event shall TI's liability arising out of such information exceed the total purchase price of the TI part(s) at issue in this document sold by TI to Customer on an annual basis.

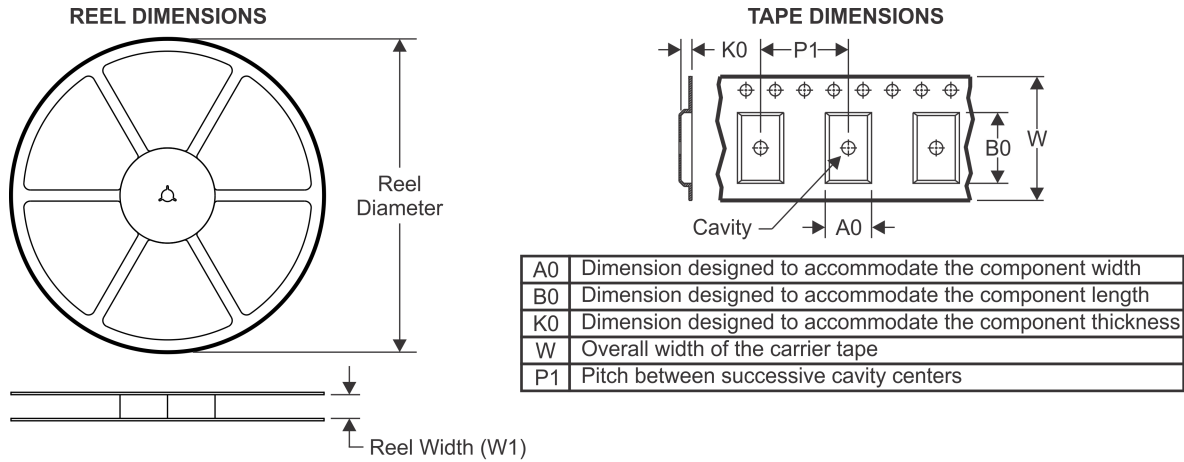
TAPE AND REEL INFORMATION

QUADRANT ASSIGNMENTS FOR PIN 1 ORIENTATION IN TAPE

*All dimensions are nominal

Device	Package Type	Package Drawing	Pins	SPQ	Reel Diameter (mm)	Reel Width W1 (mm)	A0 (mm)	B0 (mm)	K0 (mm)	P1 (mm)	W (mm)	Pin1 Quadrant
TPS7A6301QPWPRQ1	HTSSOP	PWP	14	2000	330.0	12.4	6.9	5.6	1.6	8.0	12.0	Q1
TPS7A6333QDRKRQ1	VSON	DRK	10	3000	330.0	12.4	3.3	4.3	1.1	8.0	12.0	Q2
TPS7A6333QPWPRQ1	HTSSOP	PWP	14	2000	330.0	12.4	6.9	5.6	1.6	8.0	12.0	Q1
TPS7A6350QPWPRQ1	HTSSOP	PWP	14	2000	330.0	12.4	6.9	5.6	1.6	8.0	12.0	Q1
TPS7A6401QPWPRQ1	HTSSOP	PWP	14	2000	330.0	12.4	6.9	5.6	1.6	8.0	12.0	Q1

TAPE AND REEL BOX DIMENSIONS

*All dimensions are nominal

Device	Package Type	Package Drawing	Pins	SPQ	Length (mm)	Width (mm)	Height (mm)
TPS7A6301QPWPRQ1	HTSSOP	PWP	14	2000	350.0	350.0	43.0
TPS7A6333QDRKRQ1	VSON	DRK	10	3000	367.0	367.0	35.0
TPS7A6333QPWPRQ1	HTSSOP	PWP	14	2000	350.0	350.0	43.0
TPS7A6350QPWPRQ1	HTSSOP	PWP	14	2000	350.0	350.0	43.0
TPS7A6401QPWPRQ1	HTSSOP	PWP	14	2000	350.0	350.0	43.0

THERMAL PAD MECHANICAL DATA

DRK (S-PVSON-N10)

PLASTIC SMALL OUTLINE NO-LEAD

THERMAL INFORMATION

This package incorporates an exposed thermal pad that is designed to be attached directly to an external heatsink. The thermal pad must be soldered directly to the printed circuit board (PCB). After soldering, the PCB can be used as a heatsink. In addition, through the use of thermal vias, the thermal pad can be attached directly to the appropriate copper plane shown in the electrical schematic for the device, or alternatively, can be attached to a special heatsink structure designed into the PCB. This design optimizes the heat transfer from the integrated circuit (IC).

For information on the Quad Flatpack No-Lead (QFN) package and its advantages, refer to Application Report, QFN/SON PCB Attachment, Texas Instruments Literature No. SLUA271. This document is available at www.ti.com.

The exposed thermal pad dimensions for this package are shown in the following illustration.

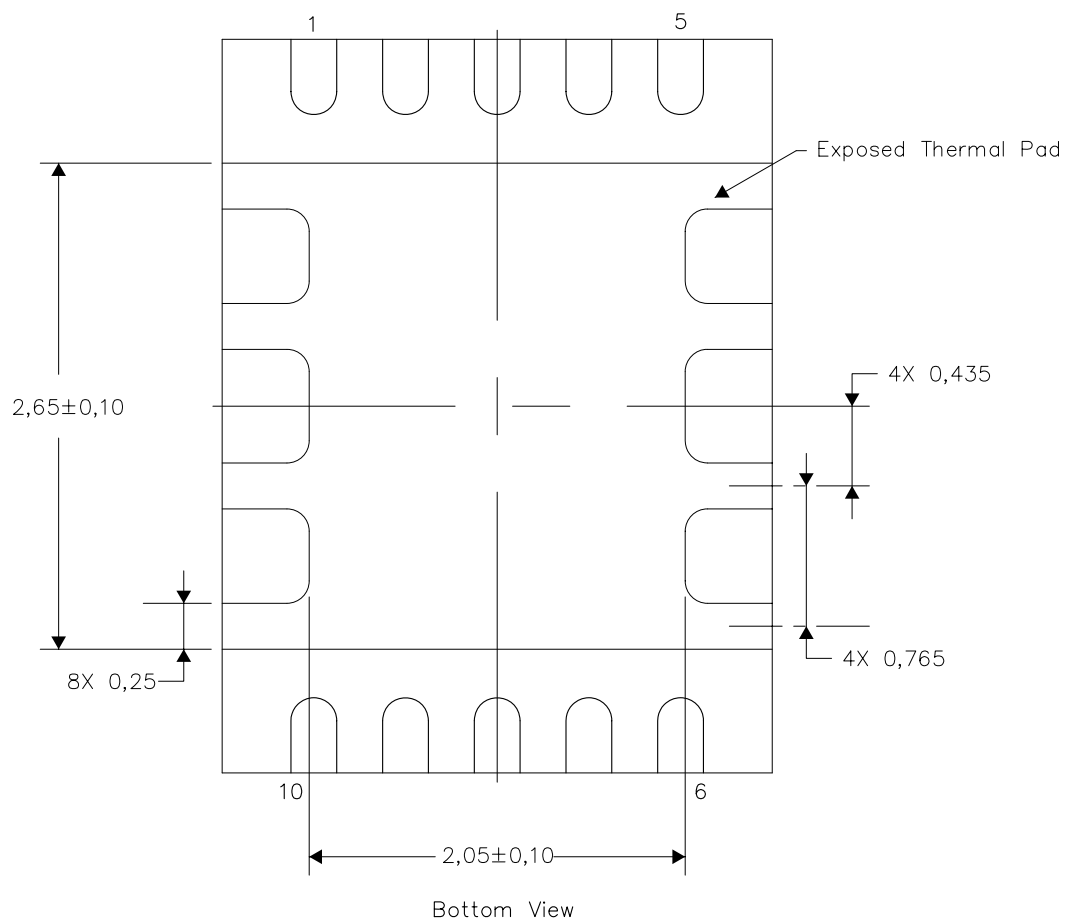

Exposed Thermal Pad Dimensions

4206317/F 08/10

NOTE: A. All linear dimensions are in millimeters

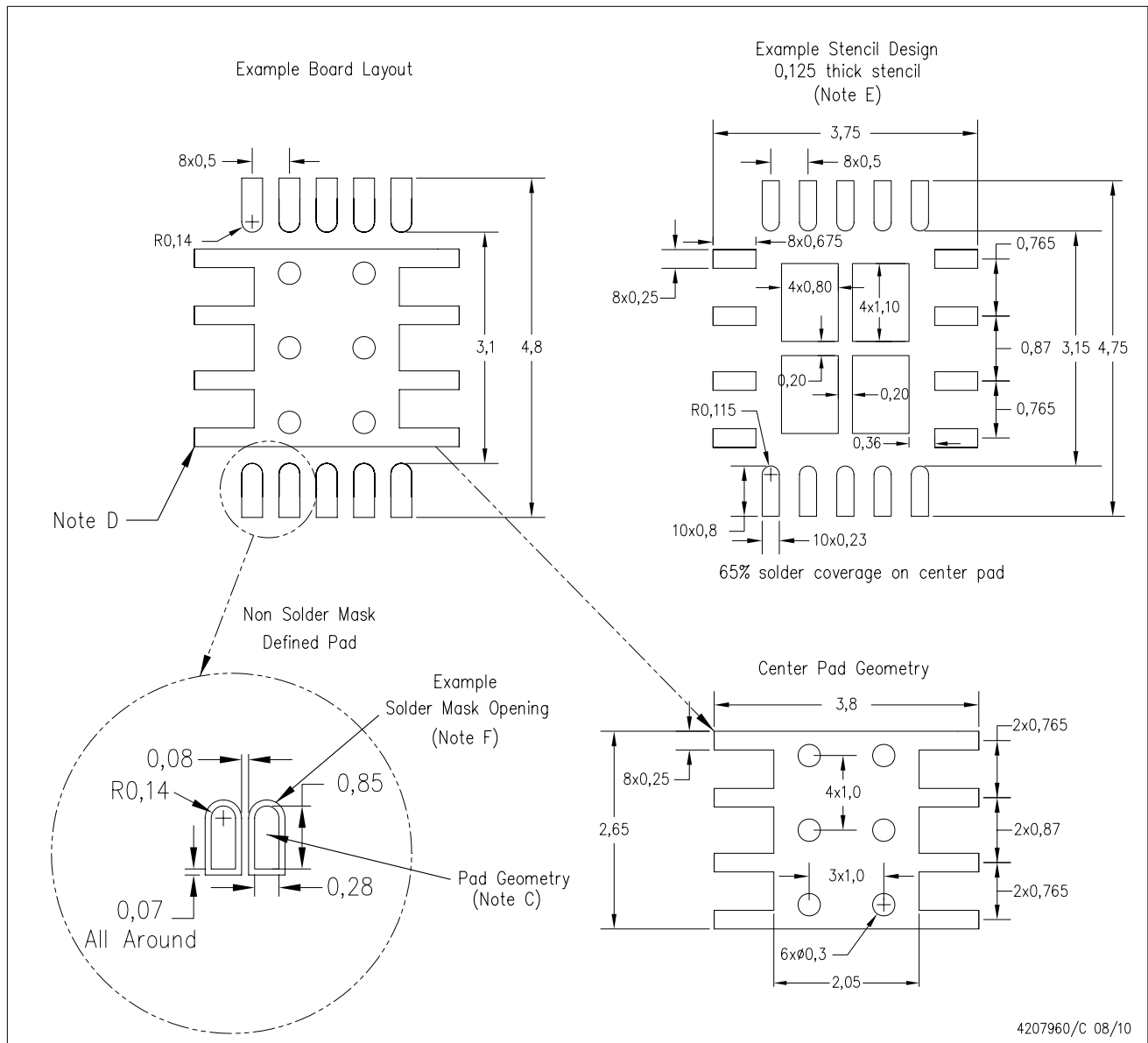

- NOTES:
- A. All linear dimensions are in millimeters.
 - B. This drawing is subject to change without notice.
 - C. Publication IPC-7351 is recommended for alternate designs.
 - D. This package is designed to be soldered to a thermal pad on the board. Refer to Application Note, Quad Flat-Pack Packages, Texas Instruments Literature No. SLUA271, and also the Product Data Sheets for specific thermal information, via requirements, and recommended board layout. These documents are available at www.ti.com <<http://www.ti.com>>.
 - E. Laser cutting apertures with trapezoidal walls and also rounding corners will offer better paste release. Customers should contact their board assembly site for stencil design recommendations. Refer to IPC 7525 for stencil design considerations.
 - F. Customers should contact their board fabrication site for minimum solder mask web tolerances between signal pads.

PWP (R-PDSO-G14)

PowerPAD™ PLASTIC SMALL OUTLINE

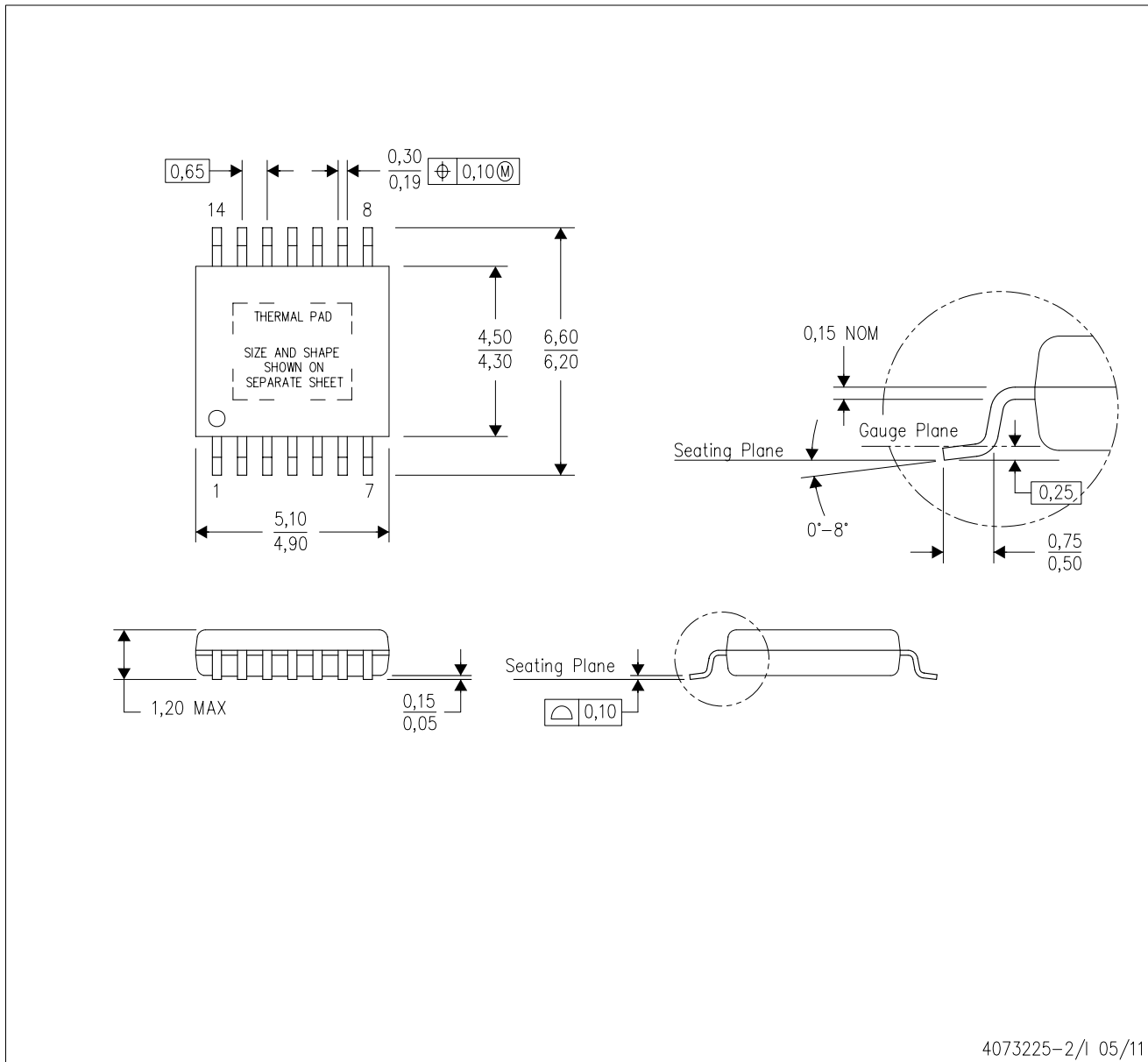

4073225-2/1 05/11

- NOTES:
- All linear dimensions are in millimeters.
 - This drawing is subject to change without notice.
 - Body dimensions do not include mold flash or protrusions. Mold flash and protrusion shall not exceed 0.15 per side.
 - This package is designed to be soldered to a thermal pad on the board. Refer to Technical Brief, PowerPad Thermally Enhanced Package, Texas Instruments Literature No. SLMA002 for information regarding recommended board layout. This document is available at www.ti.com <<http://www.ti.com>>.
 - See the additional figure in the Product Data Sheet for details regarding the exposed thermal pad features and dimensions.
 - Falls within JEDEC MO-153

PowerPAD is a trademark of Texas Instruments.

THERMAL PAD MECHANICAL DATA

PWP (R-PDSO-G14)

PowerPAD™ SMALL PLASTIC OUTLINE

THERMAL INFORMATION

This PowerPAD™ package incorporates an exposed thermal pad that is designed to be attached to a printed circuit board (PCB). The thermal pad must be soldered directly to the PCB. After soldering, the PCB can be used as a heatsink. In addition, through the use of thermal vias, the thermal pad can be attached directly to the appropriate copper plane shown in the electrical schematic for the device, or alternatively, can be attached to a special heatsink structure designed into the PCB. This design optimizes the heat transfer from the integrated circuit (IC).

For additional information on the PowerPAD package and how to take advantage of its heat dissipating abilities, refer to Technical Brief, PowerPAD Thermally Enhanced Package, Texas Instruments Literature No. SLMA002 and Application Brief, PowerPAD Made Easy, Texas Instruments Literature No. SLMA004. Both documents are available at www.ti.com.

The exposed thermal pad dimensions for this package are shown in the following illustration.

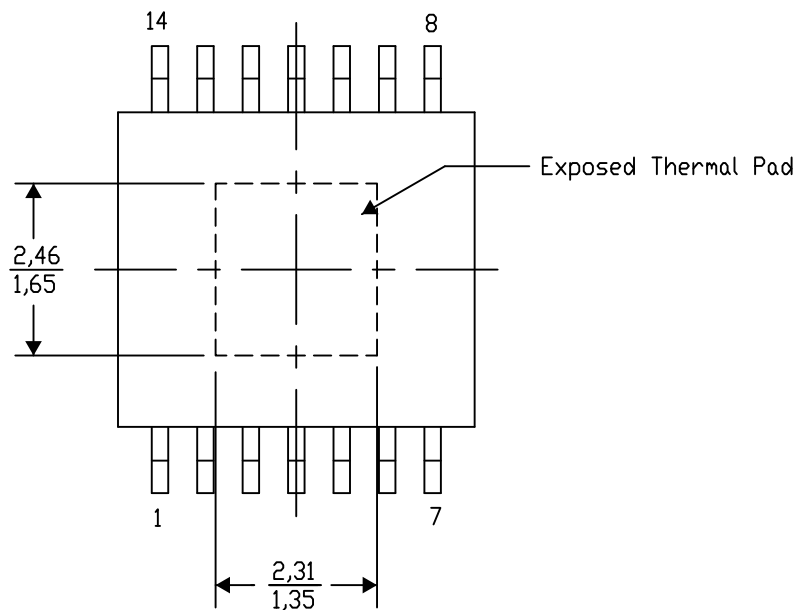

Top View

Exposed Thermal Pad Dimensions

4206332-2/AO 01/16

NOTE: A. All linear dimensions are in millimeters

PowerPAD is a trademark of Texas Instruments

PWP (R-PDSO-G14)

PowerPAD™ PLASTIC SMALL OUTLINE

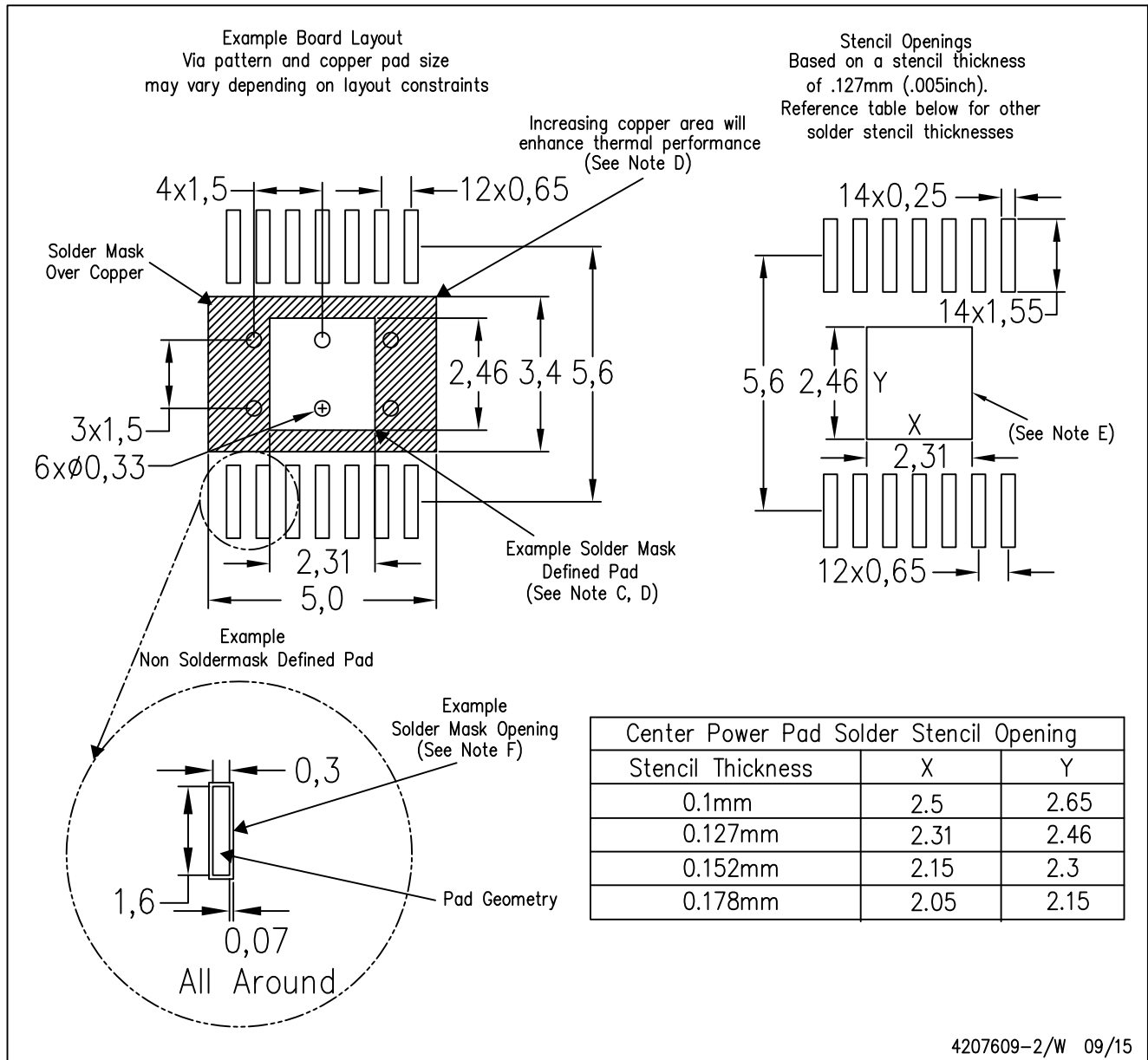

- NOTES:
- A. All linear dimensions are in millimeters.
 - B. This drawing is subject to change without notice.
 - C. Customers should place a note on the circuit board fabrication drawing not to alter the center solder mask defined pad.
 - D. This package is designed to be soldered to a thermal pad on the board. Refer to Technical Brief, PowerPAD Thermally Enhanced Package, Texas Instruments Literature No. SLMA002, SLMA004, and also the Product Data Sheets for specific thermal information, via requirements, and recommended board layout. These documents are available at www.ti.com <<http://www.ti.com>>. Publication IPC-7351 is recommended for alternate designs.
 - E. Laser cutting apertures with trapezoidal walls and also rounding corners will offer better paste release. Customers should contact their board assembly site for stencil design recommendations. Example stencil design based on a 50% volumetric metal load solder paste. Refer to IPC-7525 for other stencil recommendations.
 - F. Customers should contact their board fabrication site for solder mask tolerances between and around signal pads.

THERMAL PAD MECHANICAL DATA

PWP (R-PDSO-G14)

PowerPAD™ SMALL PLASTIC OUTLINE

THERMAL INFORMATION

This PowerPAD™ package incorporates an exposed thermal pad that is designed to be attached to a printed circuit board (PCB). The thermal pad must be soldered directly to the PCB. After soldering, the PCB can be used as a heatsink. In addition, through the use of thermal vias, the thermal pad can be attached directly to the appropriate copper plane shown in the electrical schematic for the device, or alternatively, can be attached to a special heatsink structure designed into the PCB. This design optimizes the heat transfer from the integrated circuit (IC).

For additional information on the PowerPAD package and how to take advantage of its heat dissipating abilities, refer to Technical Brief, PowerPAD Thermally Enhanced Package, Texas Instruments Literature No. SLMA002 and Application Brief, PowerPAD Made Easy, Texas Instruments Literature No. SLMA004. Both documents are available at www.ti.com.

The exposed thermal pad dimensions for this package are shown in the following illustration.

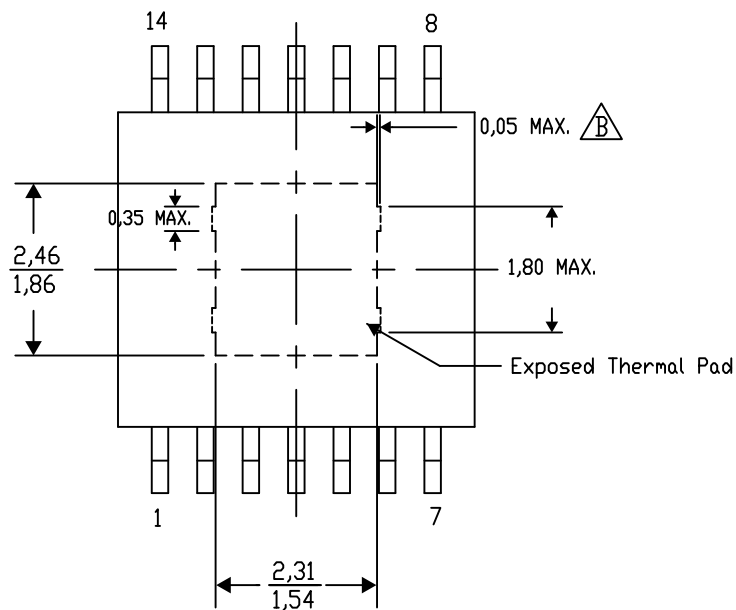

Top View

Exposed Thermal Pad Dimensions

4206332-44/AO 01/16

NOTE: A. All linear dimensions are in millimeters

 Exposed tie strap features may not be present.

PowerPAD is a trademark of Texas Instruments

PWP (R-PDSO-G14)

PowerPAD™ PLASTIC SMALL OUTLINE

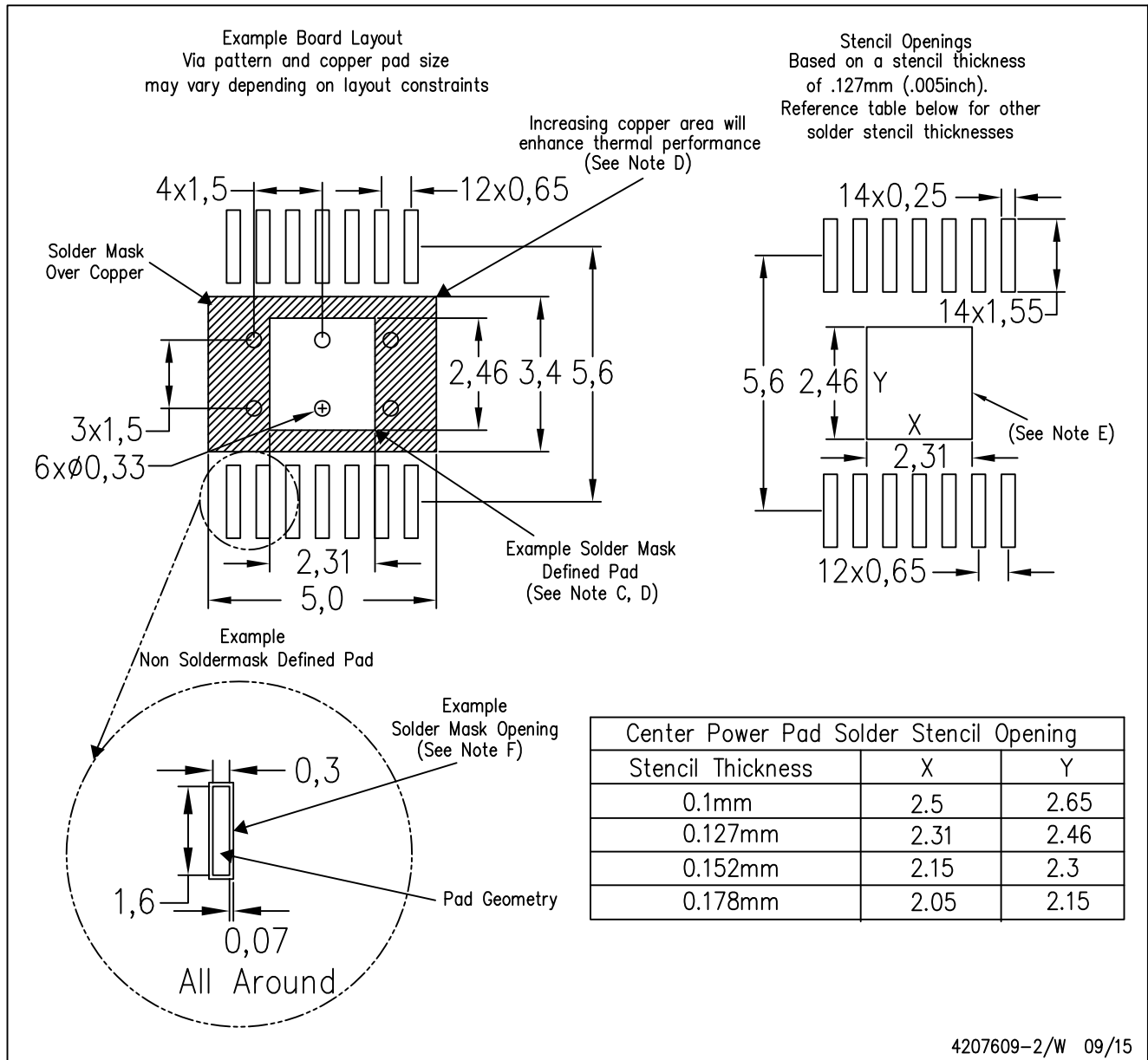

- NOTES:
- A. All linear dimensions are in millimeters.
 - B. This drawing is subject to change without notice.
 - C. Customers should place a note on the circuit board fabrication drawing not to alter the center solder mask defined pad.
 - D. This package is designed to be soldered to a thermal pad on the board. Refer to Technical Brief, PowerPAD Thermally Enhanced Package, Texas Instruments Literature No. SLMA002, SLMA004, and also the Product Data Sheets for specific thermal information, via requirements, and recommended board layout. These documents are available at www.ti.com <<http://www.ti.com>>. Publication IPC-7351 is recommended for alternate designs.
 - E. Laser cutting apertures with trapezoidal walls and also rounding corners will offer better paste release. Customers should contact their board assembly site for stencil design recommendations. Example stencil design based on a 50% volumetric metal load solder paste. Refer to IPC-7525 for other stencil recommendations.
 - F. Customers should contact their board fabrication site for solder mask tolerances between and around signal pads.

IMPORTANT NOTICE AND DISCLAIMER

TI PROVIDES TECHNICAL AND RELIABILITY DATA (INCLUDING DATASHEETS), DESIGN RESOURCES (INCLUDING REFERENCE DESIGNS), APPLICATION OR OTHER DESIGN ADVICE, WEB TOOLS, SAFETY INFORMATION, AND OTHER RESOURCES "AS IS" AND WITH ALL FAULTS, AND DISCLAIMS ALL WARRANTIES, EXPRESS AND IMPLIED, INCLUDING WITHOUT LIMITATION ANY IMPLIED WARRANTIES OF MERCHANTABILITY, FITNESS FOR A PARTICULAR PURPOSE OR NON-INFRINGEMENT OF THIRD PARTY INTELLECTUAL PROPERTY RIGHTS.

These resources are intended for skilled developers designing with TI products. You are solely responsible for (1) selecting the appropriate TI products for your application, (2) designing, validating and testing your application, and (3) ensuring your application meets applicable standards, and any other safety, security, or other requirements. These resources are subject to change without notice. TI grants you permission to use these resources only for development of an application that uses the TI products described in the resource. Other reproduction and display of these resources is prohibited. No license is granted to any other TI intellectual property right or to any third party intellectual property right. TI disclaims responsibility for, and you will fully indemnify TI and its representatives against, any claims, damages, costs, losses, and liabilities arising out of your use of these resources.

TI's products are provided subject to TI's Terms of Sale (www.ti.com/legal/termsofsale.html) or other applicable terms available either on ti.com or provided in conjunction with such TI products. TI's provision of these resources does not expand or otherwise alter TI's applicable warranties or warranty disclaimers for TI products.

Mailing Address: Texas Instruments, Post Office Box 655303, Dallas, Texas 75265
Copyright © 2019, Texas Instruments Incorporated

Looking for pricing, stock, or lifecycle information?

Click below to explore more details on WIN SOURCE:

 [View TPS7A6333QPWPRQ1](#) on WIN SOURCE

 [Texas Instruments](#) Information

Optimize Your Supply Chain with WIN SOURCE Solutions

-  Global Sourcing Solution
-  Obsolete Management
-  Cost Control Management
-  Shortage Management
-  Alternative Solution
-  Excess Inventory Management