



THE DATASHEET OF MOC3051TM



MOC3051-M

MOC3052-M

PACKAGE

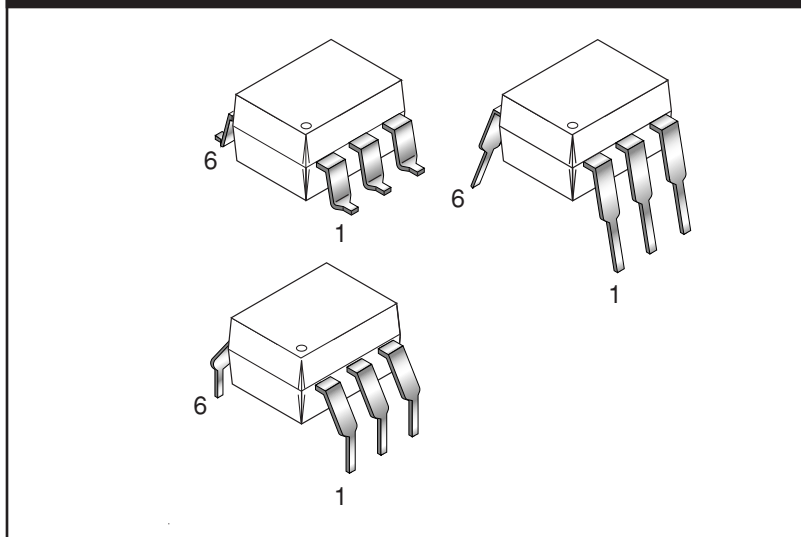

SCHEMATIC

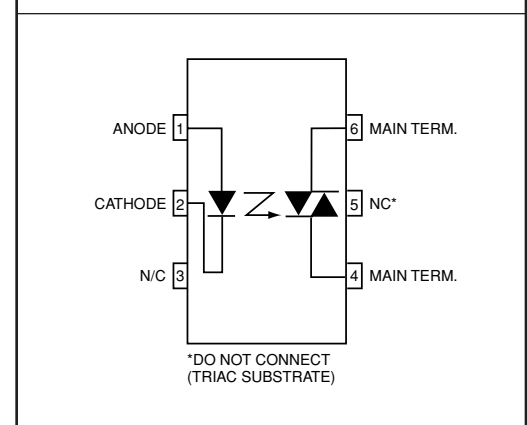

DESCRIPTION

The MOC3051-M and MOC3052-M consist of a AlGaAs infrared emitting diode optically coupled to a non-zero-crossing silicon bilateral AC switch (triac). These devices isolate low voltage logic from 115 and 240 Vac lines to provide random phase control of high current triacs or thyristors. These devices feature greatly enhanced static dv/dt capability to ensure stable switching performance of inductive loads.

FEATURES

- Excellent I_{FT} stability—IR emitting diode has low degradation
- High isolation voltage—minimum 7500 peak VAC
- Underwriters Laboratory (UL) recognized—File #E90700
- 600V peak blocking voltage
- VDE recognized (File #94766)
 - Ordering option V (e.g. MOC3052V-M)

APPLICATIONS

- Solenoid/valve controls
- Lamp ballasts
- Static AC power switch
- Interfacing microprocessors to 115 and 240 Vac peripherals
- Solid state relay
- Incandescent lamp dimmers
- Temperature controls
- Motor controls

MOC3051-M

MOC3052-M

ABSOLUTE MAXIMUM RATINGS ($T_A = 25^\circ\text{C}$ unless otherwise noted)				
Parameters	Symbol	Device	Value	Units
TOTAL DEVICE				
Storage Temperature	T_{STG}	All	-40 to +150	$^\circ\text{C}$
Operating Temperature	T_{OPR}	All	-40 to +85	$^\circ\text{C}$
Lead Solder Temperature	T_{SOL}	All	260 for 10 sec	$^\circ\text{C}$
Junction Temperature Range	T_J	All	-40 to +100	$^\circ\text{C}$
Isolation Surge Voltage ⁽³⁾ (peak AC voltage, 60Hz, 1 sec duration)	V_{ISO}	All	7500	Vac(pk)
Total Device Power Dissipation @ 25 $^\circ\text{C}$	P_D	All	330	mW
Derate above 25 $^\circ\text{C}$			4.4	mW/ $^\circ\text{C}$
EMITTER				
Continuous Forward Current	I_F	All	60	mA
Reverse Voltage	V_R	All	3	V
Total Power Dissipation 25 $^\circ\text{C}$ Ambient	P_D	All	100	mW
Derate above 25 $^\circ\text{C}$			1.33	mW/ $^\circ\text{C}$
DETECTOR				
Off-State Output Terminal Voltage	V_{DRM}	All	600	V
Peak Repetitive Surge Current (PW = 100 ms, 120 pps)	I_{TSM}	All	1	A
Total Power Dissipation @ 25 $^\circ\text{C}$ Ambient	P_D	All	300	mW
Derate above 25 $^\circ\text{C}$			4	mW/ $^\circ\text{C}$

MOC3051-M

MOC3052-M

ELECTRICAL CHARACTERISTICS ($T_A = 25^\circ\text{C}$ Unless otherwise specified)

INDIVIDUAL COMPONENT CHARACTERISTICS

Parameters	Test Conditions	Symbol	Device	Min	Typ*	Max	Units
EMITTER							
Input Forward Voltage	$I_F = 10\text{ mA}$	V_F	All		1.15	1.5	V
Reverse Leakage Current	$V_R = 3\text{ V}$	I_R	All		0.05	100	μA
DETECTOR							
Peak Blocking Current, Either Direction	$V_{\text{DRM}}, I_F = 0$ (note 1)	I_{DRM}	All		10	100	nA
Peak On-State Voltage, Either Direction	$I_{\text{TM}} = 100\text{ mA peak}, I_F = 0$	V_{TM}	All		1.7	2.5	V
Critical Rate of Rise of Off-State Voltage	$I_F = 0$ (figure 7, @400V)	dv/dt	All	1000			V/ μs

TRANSFER CHARACTERISTICS ($T_A = 25^\circ\text{C}$ Unless otherwise specified.)

DC Characteristics	Test Conditions	Symbol	Device	Min	Typ*	Max	Units
LED Trigger Current, either direction	Main terminal Voltage = 3V (note 2)	I_{FT}	MOC3051-M			15	mA
			MOC3052-M			10	
Holding Current, Either Direction		I_H	All		280		μA

*Typical values at $T_A = 25^\circ\text{C}$

Note

1. Test voltage must be applied within dv/dt rating.
2. All devices are guaranteed to trigger at an I_F value less than or equal to max I_{FT} . Therefore, recommended operating I_F lies between max 15 mA for MOC3051, 10 mA for MOC3052 and absolute max I_F (60 mA).
3. Isolation surge voltage, VISO, is an internal device breakdown rating. For this text, pins 1 and 2 are common, and pins 4, 5 and 6 are common.

MOC3051-M

MOC3052-M

Figure. 1 LED Forward Voltage vs. Forward Current

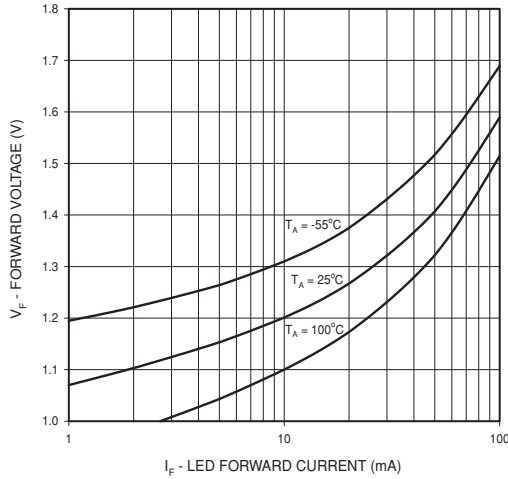

Figure. 2 On-State Characteristics

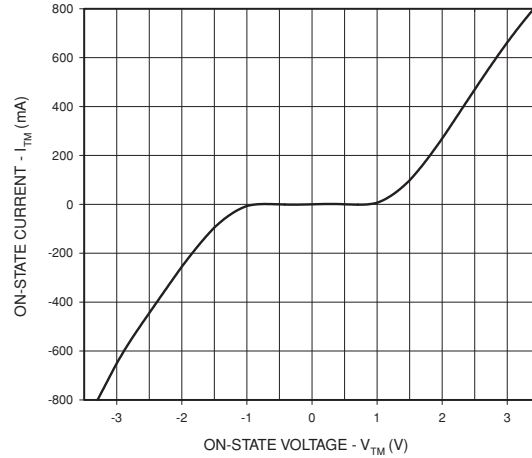

Figure. 3 Trigger Current vs. Ambient Temperature

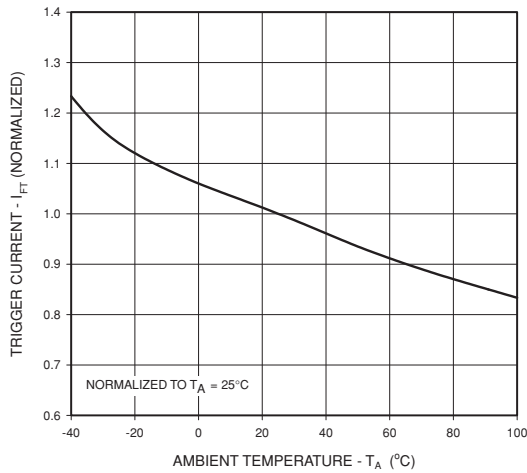
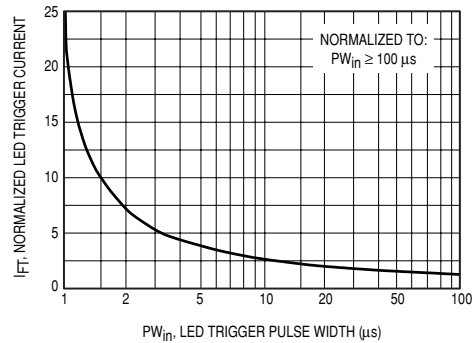

Figure. 4 LED Current Required to Trigger vs. LED Pulse Width



I_F versus Temperature (normalized)

This graph (figure 3) shows the increase of the trigger current when the device is expected to operate at an ambient temperature below 25°C. Multiply the normalized I_{FT} shown in this graph with the data sheet guaranteed I_{FT}.

Example:

T_A = -40°C, I_{FT} = 10 mA
I_{FT} @ -40°C = 10 mA x 1.4 = 14 mA

Phase Control Considerations

LED Trigger Current versus PW (normalized)

Random Phase Triac drivers are designed to be phase controllable. They may be triggered at any phase angle within the AC

sine wave. Phase control may be accomplished by an AC line zero cross detector and a variable pulse delay generator which is synchronized to the zero cross detector. The same task can be accomplished by a microprocessor which is synchronized to the AC zero crossing. The phase controlled trigger current may be a very short pulse which saves energy delivered to the input LED. LED trigger pulse currents shorter than 100 µs must have an increased amplitude as shown on Figure 4. This graph shows the dependency of the trigger current I_{FT} versus the pulse width can be seen on the chart delay t(d) versus the LED trigger current.

I_{FT} in the graph I_{FT} versus (PW) is normalized in respect to the minimum specified I_{FT} for static condition, which is specified in the device characteristic. The normalized I_{FT} has to be multiplied with the devices guaranteed static trigger current.

Example:

Guaranteed I_{FT} = 10 mA, Trigger pulse width PW = 3 µs
I_{FT} (pulsed) = 10 mA x 5 = 50 mA

MOC3051-M

MOC3052-M

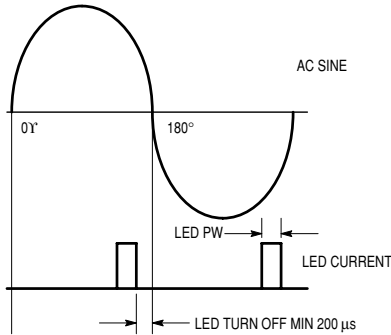

Figure 5. Minimum Time for LED Turn-Off to Zero Cross of AC Trailing Edge

Minimum LED Off Time in Phase Control Applications

In Phase control applications one intends to be able to control each AC sine half wave from 0 to 180 degrees. Turn on at zero degrees means full power and turn on at 180 degree means zero power. This is not quite possible in reality because triac driver and triac have a fixed turn on time when activated at zero degrees. At a phase control angle close to 180 degrees the driver's turn on pulse at the trailing edge of the AC sine wave must be limited to end 200 ms before AC zero cross as shown in Figure 5. This assures that the triac driver has time to switch off. Shorter times may cause loss of control at the following half cycle.

Figure 6 Holding Current, I_H vs. Temperature

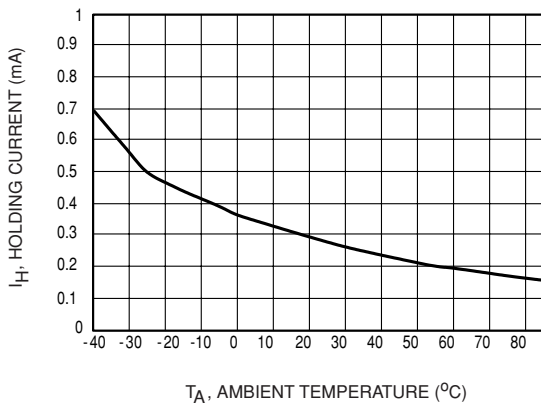

Figure 7 Leakage Current, I_{DRM} vs. Temperature

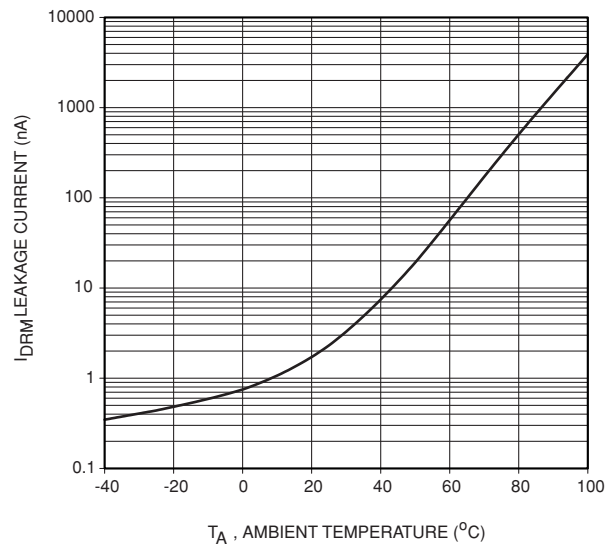
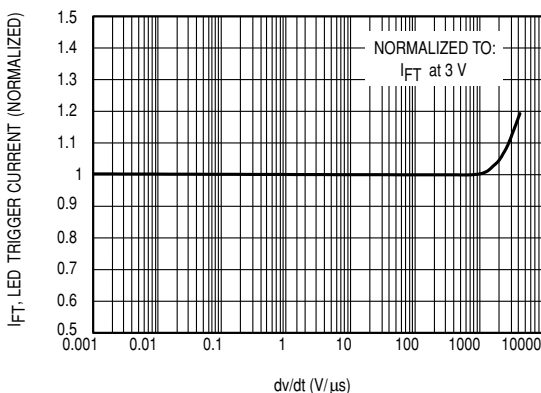

Figure 8 LED Trigger Current, I_{FT} vs. dv/dt



I_{FT} versus dv/dt

Triac drivers with good noise immunity (dv/dt static) have internal noise rejection circuits which prevent false triggering of the device in the event of fast raising line voltage transients. Inductive loads generate a commutating dv/dt that may activate the triac drivers noise suppression circuits. This prevents the device from turning on at its specified trigger current. It will in this case go into the mode of "half waving" of the load. Half waving of the load may destroy the power triac and the load.

Figure 8 shows the dependency of the triac drivers I_{FT} versus the reapplied voltage rise with a V_p of 400 V. This dv/dt condition simulates a worst case commutating dv/dt amplitude.

It can be seen that the I_{FT} does not change until a commutating dv/dt reaches 1000 V/ms. The data sheet specified I_{FT} is therefore applicable for all practical inductive loads and load factors.

MOC3051-M

MOC3052-M

Figure 9. Delay Time, t(d), and Fall Time, t(f), vs. LED Trigger Current

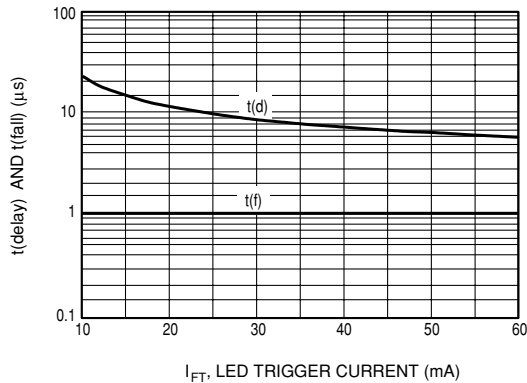

t(delay), t(f) versus I_{FT}

The triac driver's turn on switching speed consists of a turn on delay time $t(d)$ and a fall time $t(f)$. Figure 9 shows that the delay time depends on the LED trigger current, while the actual trigger transition time $t(f)$ stays constant with about one micro second.

The delay time is important in very short pulsed operation because it demands a higher trigger current at very short trigger pulses. This dependency is shown in the graph I_{FT} versus LED PW.

The turn on transition time $t(f)$ combined with the power triac's turn on time is important to the power dissipation of this device.

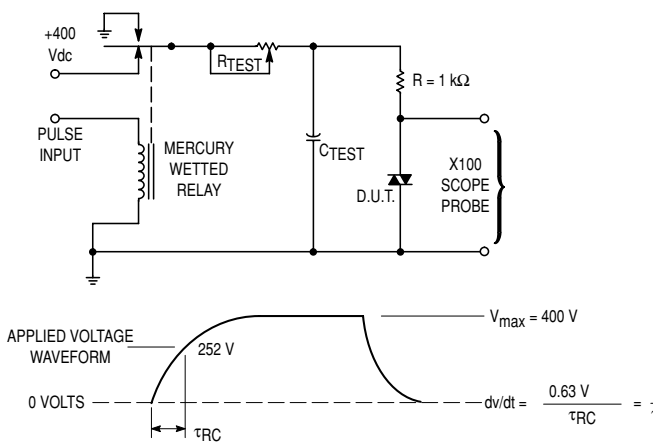
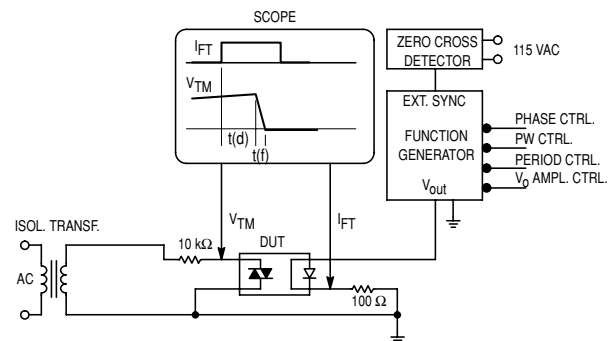

Figure 10. Static dv/dt Test Circuit



1. The mercury wetted relay provides a high speed repeated pulse to the D.U.T.
2. 100x scope probes are used, to allow high speeds and voltages.
3. The worst-case condition for static dv/dt is established by triggering the D.U.T. with a normal LED input current, then removing the current. The variable R_{TEST} allows the dv/dt to be gradually increased until the D.U.T. continues to trigger in response to the applied voltage pulse, even after the LED current has been removed. The dv/dt is then decreased until the D.U.T. stops triggering. τ_{RC} is measured at this point and recorded.

MOC3051-M

MOC3052-M

APPLICATIONS GUIDE

Basic Triac Driver Circuit

The new random phase triac driver family MOC3052-M and MOC3051-M are very immune to static dv/dt which allows snubberless operations in all applications where external generated noise in the AC line is below its guaranteed dv/dt withstand capability. For these applications a snubber circuit is not necessary when a noise insensitive power triac is used. Figure 11 shows the circuit diagram. The triac driver is directly connected to the triac main terminal 2 and a series Resistor R which limits the current to the triac driver. Current limiting resistor R must have a minimum value which restricts the current into the driver to maximum 1A.

$$R = V_p AC / I_{TM} \text{ max rep.} = V_p AC / 1A$$

The power dissipation of this current limiting resistor and the triac driver is very small because the power triac carries the load current as soon as the current through driver and current limiting resistor reaches the trigger current of the power triac. The switching transition times for the driver is only one micro second and for power triacs typical four micro seconds.

Triac Driver Circuit for Noisy Environments

When the transient rate of rise and amplitude are expected to exceed the power triacs and triac drivers maximum ratings a snubber circuit as shown in Figure 12 is recommended. Fast transients are slowed by the R-C snubber and excessive amplitudes are clipped by the Metal Oxide Varistor MOV.

Triac Driver Circuit for Extremely Noisy Environments, as specified in the noise standards IEEE472 and IEC255-4.

Industrial control applications do specify a maximum transient noise dv/dt and peak voltage which is superimposed onto the AC line voltage. In order to pass this environment noise test a modified snubber network as shown in Figure 13 is recommended.

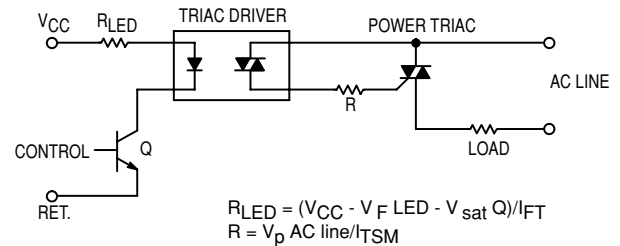
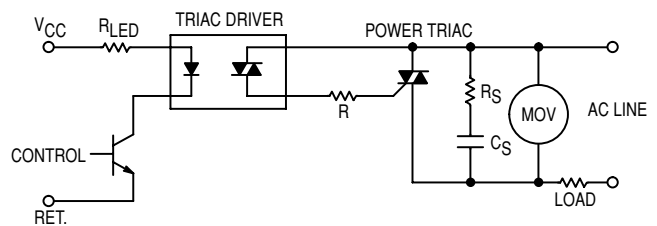

Figure 11. Basic Driver Circuit

$$R_{LED} = (V_{CC} - V_{F LED} - V_{sat Q}) / I_{FT}$$

$$R = V_p AC \text{ line} / I_{TSM}$$



Typical Snubber values $R_S = 33 \Omega$, $C_S = 0.01 \mu F$
MOV (Metal Oxide Varistor) protects triac and driver from transient overvoltages $> V_{DRM} \text{ max.}$

Figure 12. Triac Driver Circuit for Noisy Environments

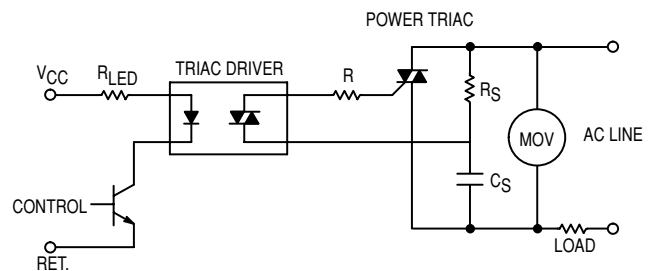

Recommended snubber to pass IEEE472 and IEC255-4 noise tests
 $R_S = 47 W$, $C_S = 0.01 mF$

Figure 13. Triac Driver Circuit for Extremely Noisy Environments

MOC3051-M

MOC3052-M

Package Dimensions (Through Hole)

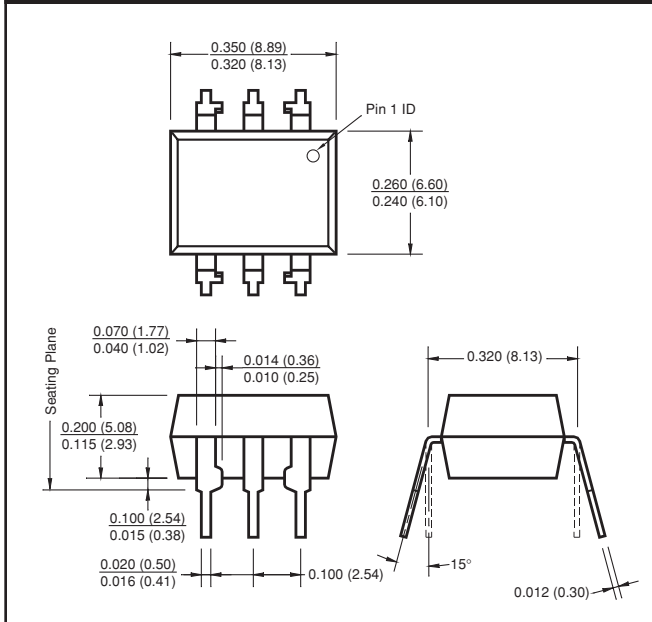

Package Dimensions (Surface Mount)

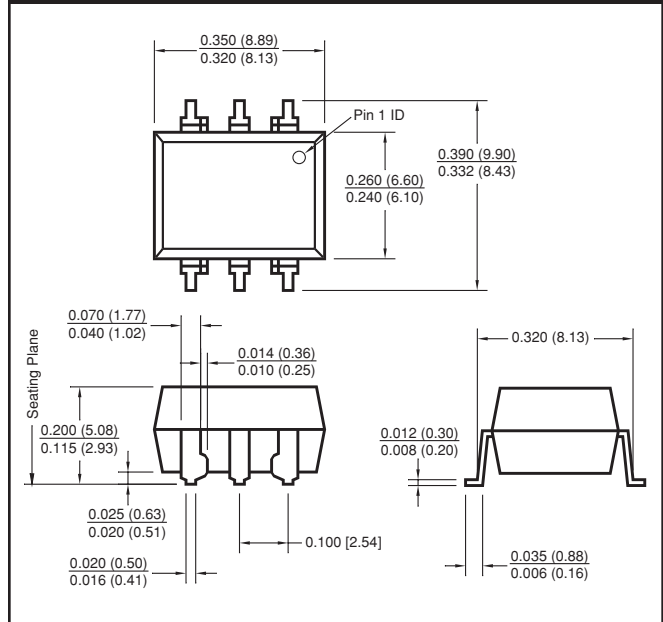

Package Dimensions (0.4" Lead Spacing)

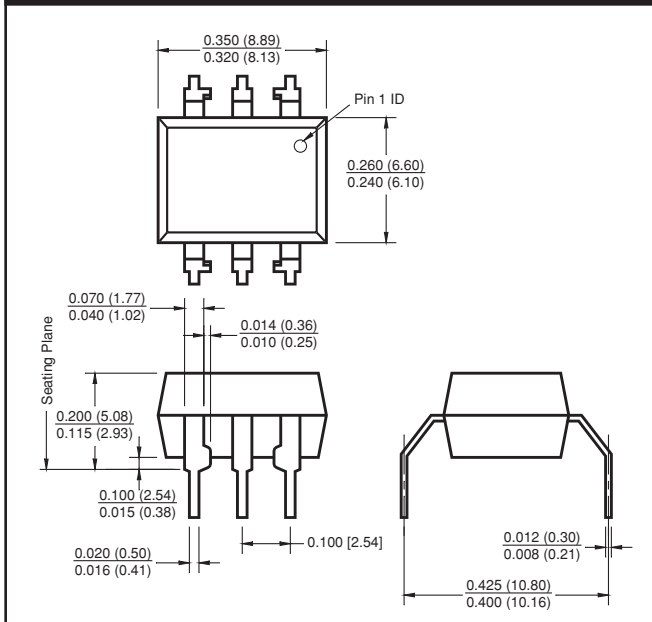

**Recommended Pad Layout for
Surface Mount Leadform**

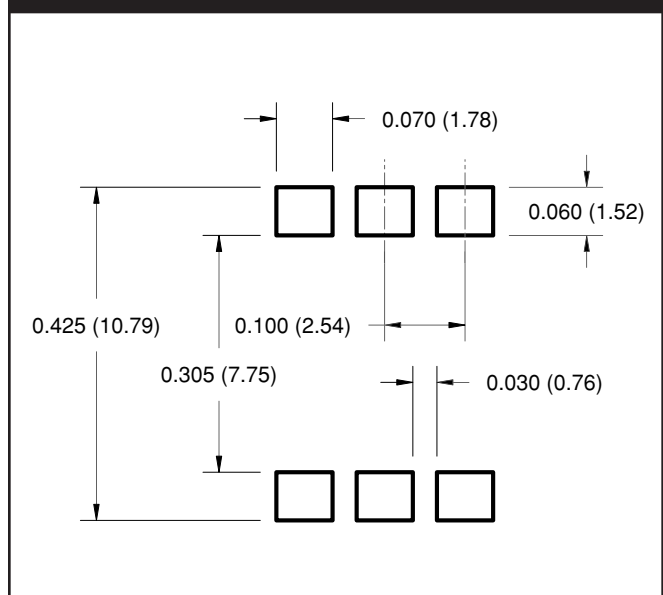

NOTE

All dimensions are in inches (millimeters)

MOC3051-M

MOC3052-M

ORDERING INFORMATION

Option	Order Entry Identifier	Description
S	S	Surface Mount Lead Bend
SD	SR2	Surface Mount; Tape and reel
W	T	0.4" Lead Spacing
300	V	VDE 0884
300W	TV	VDE 0884, 0.4" Lead Spacing
3S	SR2V	VDE 0884, Surface Mount
3SD	SR2V	VDE 0884, Surface Mount, Tape & Reel

MARKING INFORMATION

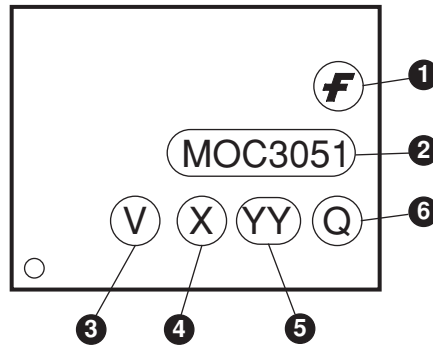

Definitions	
1	Fairchild logo
2	Device number
3	VDE mark (Note: Only appears on parts ordered with VDE option – See order entry table)
4	One digit year code, e.g., '3'
5	Two digit work week ranging from '01' to '53'
6	Assembly package code

*Note – Parts that do not have the 'V' option (see definition 3 above) that are marked with date code '325' or earlier are marked in portrait format.

MOC3051-M

MOC3052-M

Carrier Tape Specifications

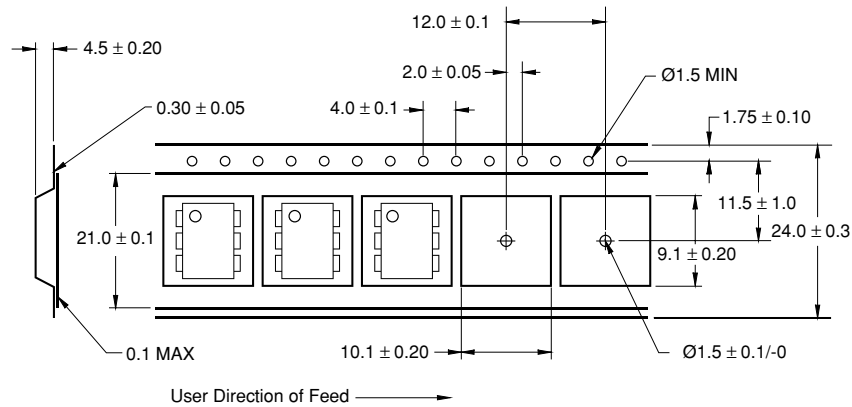

Reflow Profile (White Package, -M Suffix)

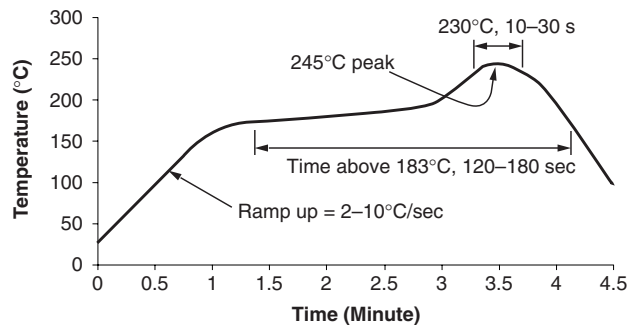

- Peak reflow temperature: 245°C (package surface temperature)
- Time of temperature higher than 183°C for 120–180 seconds
- One time soldering reflow is recommended

MOC3051-M

MOC3052-M

DISCLAIMER

FAIRCHILD SEMICONDUCTOR RESERVES THE RIGHT TO MAKE CHANGES WITHOUT FURTHER NOTICE TO ANY PRODUCTS HEREIN TO IMPROVE RELIABILITY, FUNCTION OR DESIGN. FAIRCHILD DOES NOT ASSUME ANY LIABILITY ARISING OUT OF THE APPLICATION OR USE OF ANY PRODUCT OR CIRCUIT DESCRIBED HEREIN; NEITHER DOES IT CONVEY ANY LICENSE UNDER ITS PATENT RIGHTS, NOR THE RIGHTS OF OTHERS.



LIFE SUPPORT POLICY

FAIRCHILD'S PRODUCTS ARE NOT AUTHORIZED FOR USE AS CRITICAL COMPONENTS IN LIFE SUPPORT DEVICES OR SYSTEMS WITHOUT THE EXPRESS WRITTEN APPROVAL OF THE PRESIDENT OF FAIRCHILD SEMICONDUCTOR CORPORATION. As used herein:

1. Life support devices or systems are devices or systems which, (a) are intended for surgical implant into the body, or (b) support or sustain life, and (c) whose failure to perform when properly used in accordance with instructions for use provided in the labeling, can be reasonably expected to result in a significant injury of the user.
2. A critical component in any component of a life support device or system whose failure to perform can be reasonably expected to cause the failure of the life support device or system, or to affect its safety or effectiveness.

Looking for pricing, stock, or lifecycle information?

Click below to explore more details on WIN SOURCE:

-  [View MOC3051TM on WIN SOURCE](#)
-  [Fairchild/ON Semiconductor Information](#)

Optimize Your Supply Chain with WIN SOURCE Solutions

-  Global Sourcing Solution
-  Obsolete Management
-  Cost Control Management
-  Shortage Management
-  Alternative Solution
-  Excess Inventory Management