



**THE DATASHEET OF
TPS70202PWPR**



DUAL-OUTPUT, LOW DROPOUT VOLTAGE REGULATORS WITH INTEGRATED SVS FOR SPLIT VOLTAGE SYSTEMS

FEATURES

- Dual Output Voltages for Split-Supply Applications
- Independent Enable Functions (See Part Number TPS701xx for Sequenced Outputs)
- Output Current Range of 500mA on Regulator 1 and 250mA on Regulator 2
- Fast Transient Response
- Voltage Options: 3.3V/2.5V, 3.3V/1.8V, 3.3V/1.5V, 3.3V/1.2V, and Dual Adjustable Outputs
- Open Drain Power-On Reset with 120ms Delay
- Open Drain Power Good for Regulator 1 and Regulator 2
- Ultralow 190µA (typ) Quiescent Current
- 1µA Input Current During Standby
- Low Noise: 65µV_{RMS} Without Bypass Capacitor
- Quick Output Capacitor Discharge Feature
- One Manual Reset Input
- 2% Accuracy Over Load and Temperature
- Undervoltage Lockout (UVLO) Feature
- 20-Pin PowerPAD™ TSSOP Package
- Thermal Shutdown Protection

DESCRIPTION

The TPS702xx is a low dropout voltage regulator with integrated SVS (RESET, POR, or power on reset) and power good (PG) functions. These devices are capable of supplying 500mA and 250mA by regulator 1 and regulator 2 respectively. Quiescent current is typically 190µA at full load. Differentiated features, such as accuracy, fast transient response, SVS supervisory circuit (power on reset), manual reset input, and independent enable functions provide a complete system solution.

**PWP PACKAGE
(TOP VIEW)**

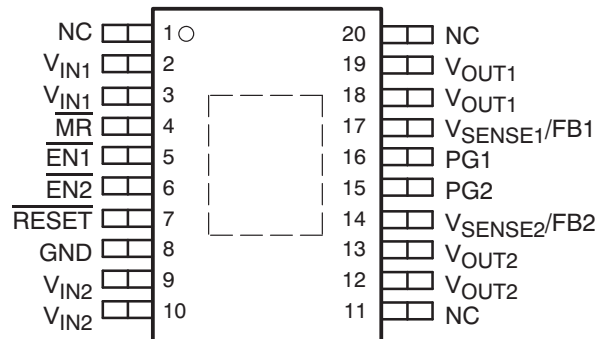

NC = No internal connection

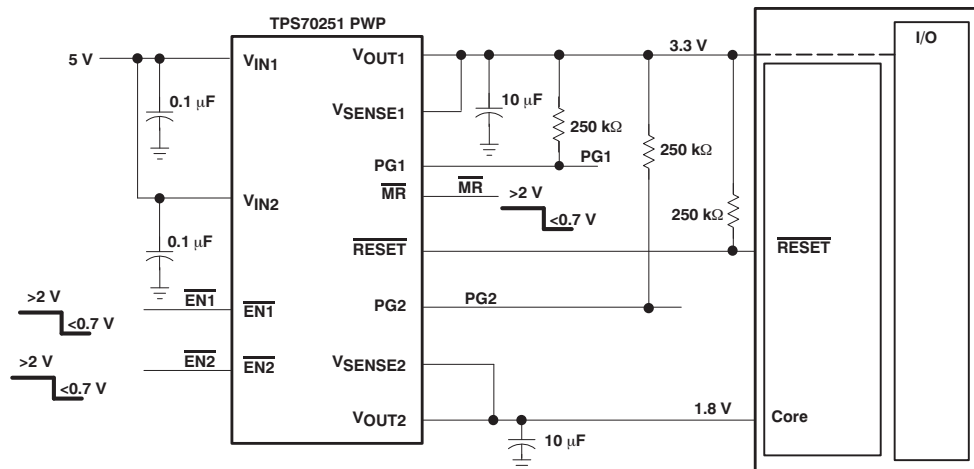

Please be aware that an important notice concerning availability, standard warranty, and use in critical applications of Texas Instruments semiconductor products and disclaimers thereto appears at the end of this data sheet.

PowerPAD is a trademark of Texas Instruments.
All other trademarks are the property of their respective owners.

The TPS702xx family of voltage regulators offers very low dropout voltage and dual outputs. These devices have extremely low noise output performance without using any added filter bypass capacitors and are designed to have a fast transient response and be stable with 10 μ F low ESR capacitors.

These devices have fixed 3.3V/2.5V, 3.3V/1.8V, 3.3V/1.5V, 3.3V/1.2V, and adjustable voltage options. Regulator 1 can support up to 500mA, and regulator 2 can support up to 250mA. Separate voltage inputs allow the designer to configure the source power.

Because the PMOS device behaves as a low-value resistor, the dropout voltage is very low (typically 170mV on regulator 1) and is directly proportional to the output current. Additionally, since the PMOS pass element is a voltage-driven device, the quiescent current is very low and independent of output loading (maximum of 230 μ A over the full range of output current and full range of temperature). This LDO family also features a sleep mode; applying a high signal to $\overline{\text{EN1}}$ or $\overline{\text{EN2}}$ (enable) shuts down regulator 1 or regulator 2, respectively. When a high signal is applied to both $\overline{\text{EN1}}$ and $\overline{\text{EN2}}$, both regulators enter sleep mode, thereby reducing the input current to 2 μ A at $T_J = +25^\circ\text{C}$.

For each regulator, there is an internal discharge transistor to discharge the output capacitor when the regulator is turned off (disabled).

The PG1 pin reports the voltage condition at V_{OUT1} . The PG1 pin can be used to implement a SVS ($\overline{\text{RESET}}$, POR, or power on reset) for the circuitry supplied by regulator 1. The PG2 pin reports the voltage conditions at V_{OUT2} . The PG2 pin can be used to implement a SVS (power on reset) for the circuitry supplied by regulator 2.

The TPS702xx features a $\overline{\text{RESET}}$ (SVS, POR, or power on reset). $\overline{\text{RESET}}$ output initiates a reset in the event of an undervoltage condition. $\overline{\text{RESET}}$ also indicates the status of the manual reset pin ($\overline{\text{MR}}$). When $\overline{\text{MR}}$ is in the logic high state, $\overline{\text{RESET}}$ goes to a high impedance state after a 120ms delay. To monitor V_{OUT1} , the PG1 output pin can be connected to $\overline{\text{MR}}$. To monitor V_{OUT2} , the PG2 output pin can be connected to $\overline{\text{MR}}$.

The device has an undervoltage lockout UVLO circuit that prevents the internal regulators from turning on until V_{IN1} reaches 2.5V.



This integrated circuit can be damaged by ESD. Texas Instruments recommends that all integrated circuits be handled with appropriate precautions. Failure to observe proper handling and installation procedures can cause damage.

ESD damage can range from subtle performance degradation to complete device failure. Precision integrated circuits may be more susceptible to damage because very small parametric changes could cause the device not to meet its published specifications.

ORDERING INFORMATION⁽¹⁾

| PRODUCT | VOLTAGE (V) ⁽²⁾ | | PACKAGE-LEAD (DESIGNATOR) | SPECIFIED TEMPERATURE RANGE (T _J) | ORDERING NUMBER | TRANSPORT MEDIA, QUANTITY |
|----------|----------------------------|-------------------|---------------------------|---|-----------------|---------------------------|
| | V _{OUT1} | V _{OUT2} | | | | |
| TPS70202 | Adjustable | Adjustable | HTSSOP-20 (PWP) | -40°C to +125°C | TPS70202PWP | Tube, 70 |
| | | | | | TPS70202PWPR | Tape and Reel, 2000 |
| TPS70245 | 3.3V | 1.2V | HTSSOP-20 (PWP) | -40°C to +125°C | TPS70245PWP | Tube, 70 |
| | | | | | TPS70245PWPR | Tape and Reel, 2000 |
| TPS70248 | 3.3V | 1.5V | HTSSOP-20 (PWP) | -40°C to +125°C | TPS70248PWP | Tube, 70 |
| | | | | | TPS70248PWPR | Tape and Reel, 2000 |
| TPS70251 | 3.3V | 1.8V | HTSSOP-20 (PWP) | -40°C to +125°C | TPS70251PWP | Tube, 70 |
| | | | | | TPS70251PWPR | Tape and Reel, 2000 |
| TPS70258 | 3.3V | 2.5V | HTSSOP-20 (PWP) | -40°C to +125°C | TPS70258PWP | Tube, 70 |
| | | | | | TPS70258PWPR | Tape and Reel, 2000 |

- (1) For the most current package and ordering information see the Package Option Addendum located at the end of this document, or see the TI web site at www.ti.com.
- (2) For fixed 1.20V operation, tie FB to OUT.

ABSOLUTE MAXIMUM RATINGS⁽¹⁾

Over operating free-air temperature range (unless otherwise noted).

| | TPS702xx | UNIT |
|---|---|------|
| Input voltage range: V _{IN1} , V _{IN2} ⁽²⁾ | -0.3 to +7 | V |
| Voltage range at $\overline{EN1}$, $\overline{EN2}$ | -0.3 to +7 | V |
| Output voltage range (V _{OUT1} , V _{SENSE1}) | 5.5 | V |
| Output voltage range (V _{OUT2} , V _{SENSE2}) | 5.5 | V |
| Maximum RESET, PG1, PG2 voltage | 7 | V |
| Maximum MR voltage | V _{IN1} | V |
| Peak output current | Internally limited | — |
| Continuous total power dissipation | See Dissipation Ratings Table | — |
| Operating virtual junction temperature range, T _J | -40 to +150 | °C |
| Storage temperature range, T _{stg} | -65 to +150 | °C |
| ESD rating, HBM | 2 | kV |

- (1) Stresses beyond those listed under absolute maximum ratings may cause permanent damage to the device. These are stress ratings only, and functional operation of the device at these or any other conditions beyond those indicated under recommended operating conditions is not implied. Exposure to absolute-maximum-rated conditions for extended periods may affect device reliability.
- (2) All voltages are tied to network ground.

DISSIPATION RATINGS

| PACKAGE | AIR FLOW (CFM) | T _A ≤ +25°C | DERATING FACTOR | T _A = +70°C | T _A = +85°C |
|--------------------|----------------|------------------------|-----------------|------------------------|------------------------|
| PWP ⁽¹⁾ | 0 | 3.067W | 30.67mW/°C | 1.687W | 1.227W |
| | 250 | 4.115W | 41.15mW/°C | 2.265W | 1.646W |

(1) This parameter is measured with the recommended copper heat sink pattern on a 4-layer PCB, 1 oz. copper on a 4-in by 4-in ground layer. For more information, refer to TI technical brief [SLMA002](#).

RECOMMENDED OPERATING CONDITIONS

Over operating temperature range (unless otherwise noted).

| | MIN | MAX | UNIT |
|--|------|------|------|
| Input voltage, V _I ⁽¹⁾ (regulator 1 and 2) | 2.7 | 6 | V |
| Output current, I _O (regulator 1) | 0 | 500 | mA |
| Output current, I _O (regulator 2) | 0 | 250 | mA |
| Output voltage range (for adjustable option) | 1.22 | 5.5 | V |
| Operating virtual junction temperature, T _J | -40 | +125 | °C |

(1) To calculate the minimum input voltage for maximum output current, use the following equation: $V_{I(\min)} = V_{O(\max)} + V_{DO(\max \text{ load})}$.

ELECTRICAL CHARACTERISTICS

Over recommended operating junction temperature range ($T_J = -40^\circ\text{C}$ to $+125^\circ\text{C}$), V_{IN1} or $V_{IN2} = V_{OUT(nom)} + 1\text{V}$, $I_O = 1\text{mA}$, $\overline{\text{EN}}1 = 0\text{V}$, $\overline{\text{EN}}2 = 0\text{V}$, and $C_O = 33\mu\text{F}$ (unless otherwise noted).

| PARAMETER | | TEST CONDITIONS | | MIN | TYP | MAX | UNIT | |
|--|--------------------------------------|---|--|---------------------------------|-------|-------|----------------------------|---------------|
| V_O | Reference voltage | $2.7\text{V} < V_{IN} < 6\text{V}$, $T_J = +25^\circ\text{C}$ | FB connected to V_O | | 1.22 | | V | |
| | | $2.7\text{V} < V_{IN} < 6\text{V}$, | FB connected to V_O | 1.196 | | 1.244 | | |
| | 1.2V Output | $2.7\text{V} < V_{IN} < 6\text{V}$, | $T_J = +25^\circ\text{C}$ | | 1.2 | | | |
| | | $2.7\text{V} < V_{IN} < 6\text{V}$, | | 1.176 | | 1.224 | | |
| | 1.5V Output | $2.7\text{V} < V_{IN} < 6\text{V}$, | $T_J = +25^\circ\text{C}$ | | 1.5 | | | |
| | | $2.7\text{V} < V_{IN} < 6\text{V}$, | | 1.47 | | 1.53 | | |
| | 1.8V Output | $2.8\text{V} < V_{IN} < 6\text{V}$, | $T_J = +25^\circ\text{C}$ | | 1.8 | | | |
| | | $2.8\text{V} < V_{IN} < 6\text{V}$, | | 1.764 | | 1.836 | | |
| | 2.5V Output | $3.5\text{V} < V_{IN} < 6\text{V}$, | $T_J = +25^\circ\text{C}$ | | 2.5 | | | |
| | | $3.5\text{V} < V_{IN} < 6\text{V}$, | | 2.45 | | 2.55 | | |
| 3.3V Output | $4.3\text{V} < V_{IN} < 6\text{V}$, | $T_J = +25^\circ\text{C}$ | | 3.3 | | | | |
| | $4.3\text{V} < V_{IN} < 6\text{V}$, | | 3.234 | | 3.366 | | | |
| Quiescent current (GND current) for regulator 1 and regulator 2, $\overline{\text{EN}}1 = \overline{\text{EN}}2 = 0\text{V}^{(1)}$ | | See ⁽²⁾ | $T_J = +25^\circ\text{C}$ | | 190 | | μA | |
| | | See ⁽²⁾ | | | | 230 | | |
| Output voltage line regulation ($\Delta V_O/V_O$) for regulator 1 and regulator 2 ⁽³⁾ | | $V_O + 1\text{V} < V_{IN} \leq 6\text{V}$, | $T_J = +25^\circ\text{C}^{(1)}$ | | 0.01 | | %V | |
| | | $V_O + 1\text{V} < V_{IN} \leq 6\text{V}$ | ⁽¹⁾ | | | 0.1 | | |
| Load regulation for V_{OUT1} and V_{OUT2} | | $T_J = +25^\circ\text{C}$ | | | 1 | | mV | |
| V_n | Output noise voltage | Regulator 1 | $\text{BW} = 300\text{Hz to } 50\text{kHz}$, $C_O = 33\mu\text{F}$, $T_J = +25^\circ\text{C}$ | | 65 | | μV_{RMS} | |
| | | Regulator 2 | | | 65 | | | |
| Output current limit | | Regulator 1 | $V_{OUT} = 0\text{V}$ | | 1.6 | 1.9 | A | |
| | | Regulator 2 | | | 0.750 | 1 | | |
| Thermal shutdown junction temperature | | | | | +150 | | $^\circ\text{C}$ | |
| I_I (standby) | Standby current | Regulator 1 | $\overline{\text{EN}}1 = V_{IN}$, $\overline{\text{EN}}2 = V_I$ | $T_J = +25^\circ\text{C}$ | | 2 | μA | |
| | | Regulator 2 | $\overline{\text{EN}}1 = V_{IN}$, $\overline{\text{EN}}2 = V_I$ | | | 6 | | |
| PSRR | Power-supply ripple rejection | Regulator 1 | $f = 1\text{kHz}$, $C_O = 33\mu\text{F}$, $I_{OUT1} = 500\text{mA}$ | $T_J = +25^\circ\text{C}^{(1)}$ | | 60 | dB | |
| | | Regulator 2 | $f = 1\text{kHz}$, $C_O = 33\mu\text{F}$, $I_{OUT2} = 250\text{mA}$ | $T_J = +25^\circ\text{C}^{(1)}$ | | 50 | | |
| UVLO threshold | | | | | 2.4 | 2.65 | V | |
| RESET Terminal | | | | | | | | |
| Minimum input voltage for valid $\overline{\text{RESET}}$ | | $I_{\text{RESET}} = 300\mu\text{A}$, | $V_{(\text{RESET})} \leq 0.8\text{V}$ | | 1.0 | 1.3 | V | |
| $t_{(\text{RESET})}$ | | $\overline{\text{RESET}}$ pulse duration | | | 80 | 120 | 160 | ms |
| Output low voltage | | $V_{IN} = 3.5\text{V}$, | $I_{(\text{RESET})} = 1\text{mA}$ | | | 0.15 | 0.4 | V |
| Leakage current | | $V_{(\text{RESET})} = 6\text{V}$ | | | | | 1 | μA |

(1) Minimum input operating voltage is 2.7V or $V_{O(\text{typ})} + 1\text{V}$, whichever is greater. Maximum input voltage = 6V, minimum output current = 1mA.

(2) $I_O = 1\text{mA}$ to 500mA for Regulator 1 and 1mA to 250mA for Regulator 2.

(3) If $V_O < 1.8\text{V}$ then $V_{\text{Imax}} = 6\text{V}$, $V_{\text{Imin}} = 2.7\text{V}$:
Line regulation (mV) = (%/V) $\times V_O \frac{(V_{\text{Imax}} - 2.7)}{100} \times 1000$
If $V_O > 2.5\text{V}$ then $V_{\text{Imax}} = 6\text{V}$, $V_{\text{Imin}} = V_O + 1\text{V}$:
Line regulation (mV) = (%/V) $\times V_O \frac{[V_{\text{Imax}} - (V_O + 1)]}{100} \times 1000$

ELECTRICAL CHARACTERISTICS (continued)

Over recommended operating junction temperature range ($T_J = -40^\circ\text{C}$ to $+125^\circ\text{C}$), V_{IN1} or $V_{IN2} = V_{OUT(nom)} + 1\text{V}$, $I_O = 1\text{mA}$, $\overline{EN1} = 0\text{V}$, $\overline{EN2} = 0\text{V}$, and $C_O = 33\mu\text{F}$ (unless otherwise noted).

| PARAMETER | TEST CONDITIONS | MIN | TYP | MAX | UNIT |
|---|--|-----|------|-----|---------------|
| PG1/PG2 Terminal | | | | | |
| Minimum input voltage for valid PGx | $I_{(PGx)} = 300\mu\text{A}$, $V_{(PGx)} \leq 0.8\text{V}$ | | 1.0 | 1.3 | V |
| Trip threshold voltage | V_O decreasing | 92 | 95 | 98 | % V_{OUT} |
| Hysteresis voltage | Measured at V_O | | 0.5 | | % V_{OUT} |
| $t_{r(PGX)}$ | Rising edge deglitch | | 30 | | μs |
| Output low voltage | $V_{IN} = 2.7\text{V}$, $I_{(PGx)} = 1\text{mA}$ | | 0.15 | 0.4 | V |
| Leakage current | $V_{(PGx)} = 6\text{V}$ | | | 1 | μA |
| EN1/EN2 Terminal | | | | | |
| High-level \overline{ENx} input voltage | | 2 | | | V |
| Low-level \overline{ENx} input voltage | | | | 0.7 | V |
| Input current (\overline{ENx}) | | -1 | | 1 | μA |
| MR Terminal | | | | | |
| High-level input voltage | | 2 | | | V |
| Low-level input voltage | | | | 0.7 | V |
| Pull-up current source | | | 6 | | μA |
| V_{OUT1} Terminal | | | | | |
| Dropout voltage ⁽⁴⁾ | $I_O = 500\text{mA}$, $V_{IN1} = 3.2\text{V}$ $T_J = +25^\circ\text{C}$ | | 170 | | mV |
| | $I_O = 500\text{mA}$, $V_{IN1} = 3.2\text{V}$ | | | 275 | |
| Peak output current | 2ms pulse width | | 750 | | mA |
| Discharge transistor current | $V_{OUT1} = 1.5\text{V}$ | | 7.5 | | mA |
| V_{OUT2} Terminal | | | | | |
| Peak output current | 2ms pulse width | | 375 | | mA |
| Discharge transistor current | $V_{OUT2} = 1.5\text{V}$ | | 7.5 | | mA |
| FB Terminal | | | | | |
| Input current: TPS70202 | FB = 1.8V | | 1 | | μA |

(4) Input voltage (V_{IN1} or V_{IN2}) = $V_{O(typ)} - 100\text{mV}$. For 1.5V, 1.8V and 2.5V regulators, the dropout voltage is limited by input voltage range. The 3.3V regulator input is set to 3.2V to perform this test.

DEVICE INFORMATION

Fixed Voltage Version

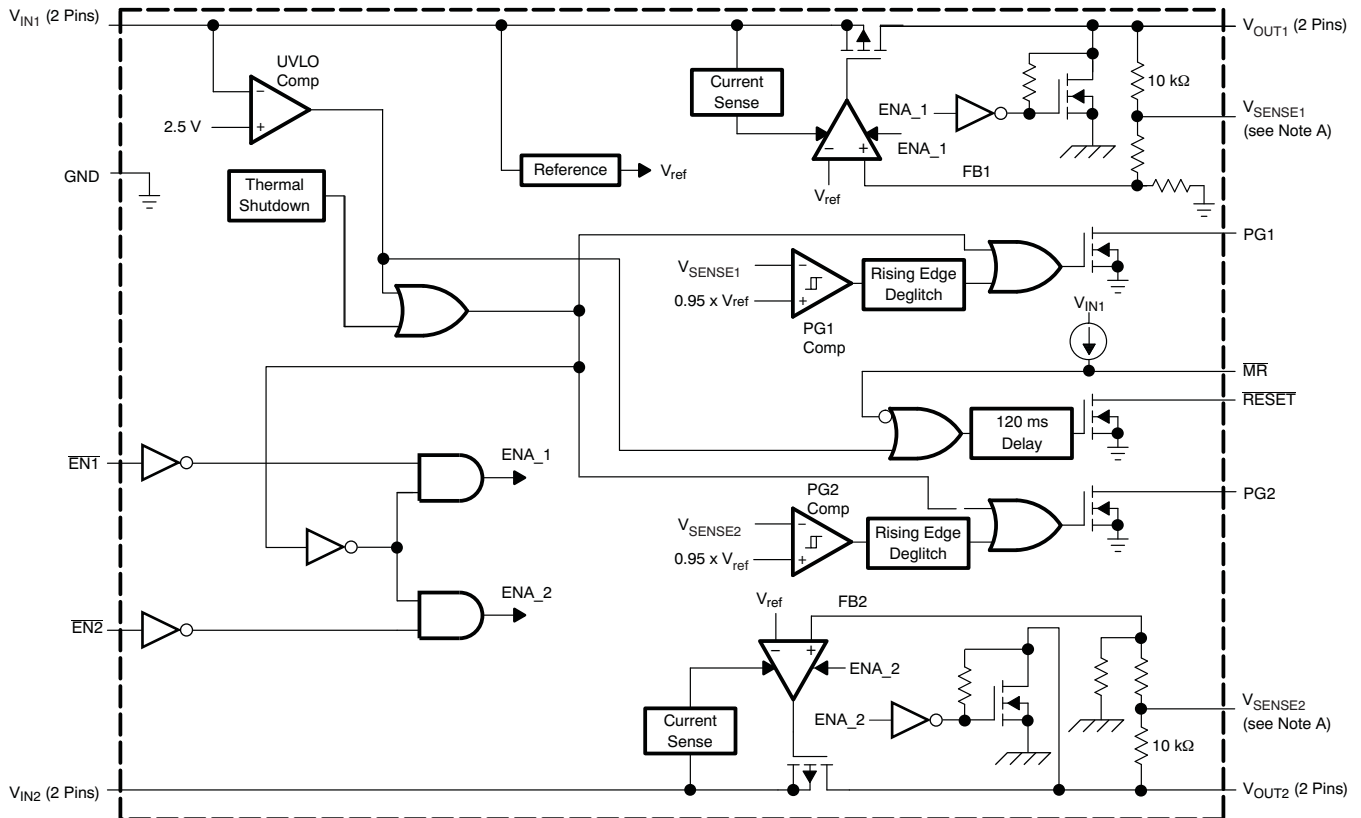

- A. For most applications, V_{SENSE1} and V_{SENSE2} should be externally connected to V_{OUT1} and V_{OUT2} , respectively, as close as possible to the device. For other implementations, refer to SENSE terminal connection discussion in the [Application Information](#) section.

Adjustable Voltage Version

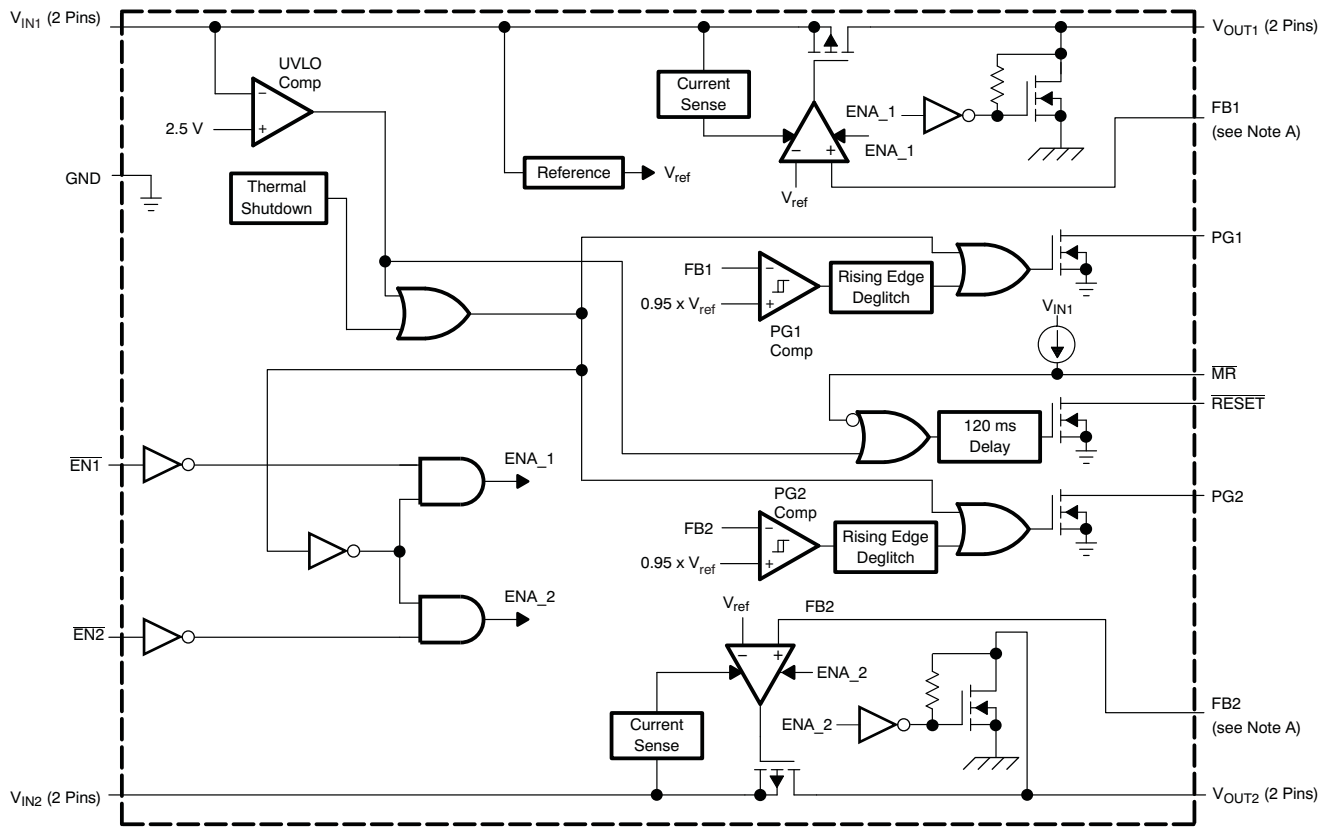

- A. For most applications, FB1 and FB2 should be externally connected to resistor dividers as close as possible to the device. For other implementations, refer to FB terminals connection discussion in the [Application Information](#) section.

RESET Timing Diagram



NOTE A: V_{RES} is the minimum input voltage for a valid \overline{RESET} . The symbol V_{RES} is not currently listed within EIA or JEDEC standards for semiconductor symbology.

PG1 Timing Diagram

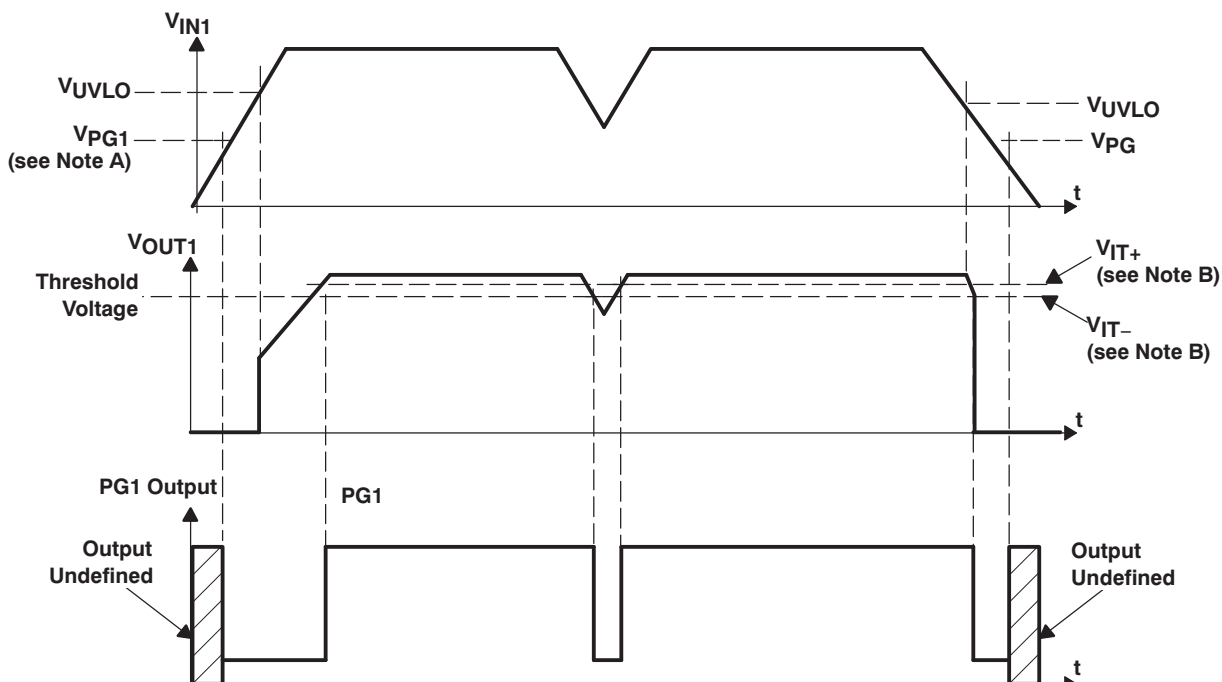

NOTES: A. V_{PG1} is the minimum input voltage for a valid $PG1$. The symbol V_{PG1} is not currently listed within EIA or JEDEC standards for semiconductor symbology.

B. V_{IT-} trip voltage is typically 5% lower than the output voltage ($95\%V_O$). V_{IT-} to V_{IT+} is the hysteresis voltage.

PG2 Timing Diagram (assuming V_{IN1} already powered up)

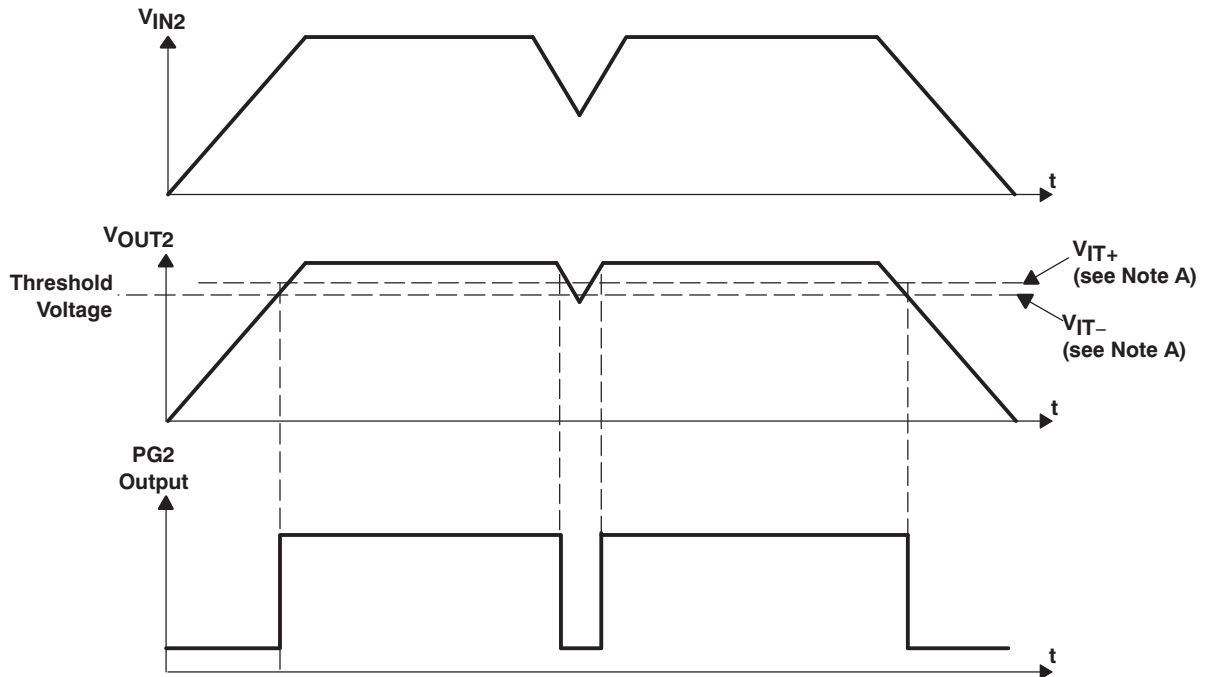

NOTE A: V_{IT-} trip voltage is typically 5% lower than the output voltage ($95\%V_O$). V_{IT-} to V_{IT+} is the hysteresis voltage.

TERMINAL FUNCTIONS

| TERMINAL | | I/O | DESCRIPTION |
|--------------------|-----------|-----|--|
| NAME | NO. | | |
| $\overline{EN1}$ | 5 | I | Active low enable for V_{OUT1} |
| $\overline{EN2}$ | 6 | I | Active low enable for V_{OUT2} |
| GND | 8 | — | Ground |
| \overline{MR} | 4 | I | Manual reset input, active low, pulled up internally |
| NC | 1, 11, 20 | — | No connection |
| PG1 | 16 | O | Open drain output, low when V_{OUT1} voltage is less than 95% of the nominal regulated voltage |
| PG2 | 15 | O | Open drain output, low when V_{OUT2} voltage is less than 95% of the nominal regulated voltage |
| \overline{RESET} | 7 | I | Open drain output, SVS (power-on reset) signal, active low |
| V_{IN1} | 2, 3 | I | Input voltage of regulator 1 |
| V_{IN2} | 9, 10 | I | Input voltage of regulator 2 |
| V_{OUT1} | 18, 19 | O | Output voltage of regulator 1 |
| V_{OUT2} | 12, 13 | O | Output voltage of regulator 2 |
| $V_{SENSE2}/FB2$ | 14 | I | Regulator 2 output voltage sense/regulator 2 feedback for adjustable |
| $V_{SENSE1}/FB1$ | 17 | I | Regulator 1 output voltage sense/regulator 1 feedback for adjustable |

Detailed Description

The TPS702xx low dropout regulator family provides dual regulated output voltages with independent enable functions. These devices provide fast transient response and high accuracy with small output capacitors, while drawing low quiescent current. Other features are integrated SVS (power-on reset, $\overline{\text{RESET}}$) and power good (PG1, PG2) that monitor output voltages and provide logic output to the system. These differentiated features provide a complete power solution.

The TPS702xx, unlike many other LDOs, features very low quiescent current that remains virtually constant even with varying loads. Conventional LDO regulators use a pnp pass element, the base current of which is directly proportional to the load current through the regulator ($I_B = I_C/\beta$). The TPS702xx uses a PMOS transistor to pass current; the gate of the PMOS is voltage-driven, so operating current is low and stable over the full load range.

Pin Functions

Enable ($\overline{\text{EN1}}$, $\overline{\text{EN2}}$)

The $\overline{\text{EN}}$ terminals are inputs that enable or shut down each respective regulator. If $\overline{\text{EN}}$ is at a voltage high signal, the respective regulator is in shutdown mode. When $\overline{\text{EN}}$ goes to voltage low, the respective regulator is enabled.

Power-Good (PG1, PG2)

The PG terminals are open drain, active high output terminals that indicate the status of each respective regulator. When V_{OUT1} reaches 95% of its regulated voltage, PG1 goes to a high impedance state. When V_{OUT2} reaches 95% of its regulated voltage, PG2 goes to a high impedance state. Each PG goes to a low impedance state when its respective output voltage is pulled below 95% (that is, goes to an overload condition) of its regulated voltage. The open drain outputs of the PG terminals require a pull-up resistor.

Manual Reset Pin

$\overline{\text{MR}}$ is an active low input terminal used to trigger a reset condition. When $\overline{\text{MR}}$ is pulled to logic low, a POR ($\overline{\text{RESET}}$) occurs. The terminal has a 6 μA pull-up current to V_{IN1} .

Sense (V_{SENSE1} , V_{SENSE2})

The sense terminals of fixed-output options must be connected to the regulator outputs, and the connection should be as short as possible. Internally, the sense terminal connects to high-impedance, wide-bandwidth amplifiers through a resistor-divider network and noise pickup feeds through to the regulator output. It is essential to route the sense connection in such a way as to minimize or avoid noise pickup. Adding RC networks between sense terminals and V_{OUT} terminals to filter noise is not recommended because these networks can cause the regulators to oscillate.

FB1 and FB2

FB1 and FB2 are input terminals used for adjustable-output devices and must be connected to the external feedback resistor divider. FB1 and FB2 connections should be as short as possible. It is essential to route them in such a way as to minimize or avoid noise pickup. Adding RC networks between FB terminals and V_{OUT} terminals to filter noise is not recommended because these networks can cause the regulators to oscillate.

RESET Indicator

The TPS702xx features a $\overline{\text{RESET}}$ (SVS, POR, or power on reset). $\overline{\text{RESET}}$ can be used to drive power on reset circuitry or a low-battery indicator. $\overline{\text{RESET}}$ is an active low, open drain output that indicates the status of the manual reset pin (MR). When MR is in a high impedance state, $\overline{\text{RESET}}$ goes to a high impedance state after a 120 ms delay. To monitor V_{OUT1} , the PG1 output pin can be connected to MR. To monitor V_{OUT2} , the PG2 output pin can be connected to MR. The open drain output of the $\overline{\text{RESET}}$ terminal requires a pull-up resistor. If $\overline{\text{RESET}}$ is not used, it can be left floating.

V_{IN1} and V_{IN2}

V_{IN1} and V_{IN2} are inputs to each regulator. **Internal bias voltages are powered by V_{IN1} .**

V_{OUT1} and V_{OUT2}

V_{OUT1} and V_{OUT2} are output terminals of each regulator.

TYPICAL CHARACTERISTICS

Table of Graphs

| | | | FIGURE |
|-------|--|------------------------------------|-------------------------|
| V_O | Output voltage | vs Output current | Figure 1 to Figure 3 |
| | | vs Junction temperature | Figure 4 to Figure 5 |
| | Ground current | vs Junction temperature | Figure 6 |
| PSRR | Power-supply rejection ratio | vs Frequency | Figure 7 to Figure 10 |
| | | Output spectral noise density | vs Frequency |
| Z_O | Output impedance | vs Frequency | Figure 15 to Figure 18 |
| | | vs Temperature | Figure 19 and Figure 20 |
| | | vs Input voltage | Figure 21 and Figure 22 |
| | Load transient response | | Figure 23 and Figure 24 |
| | Line transient response (V_{OUT1}) | | Figure 25 |
| | Line transient response (V_{OUT2}) | | Figure 26 |
| V_O | Output voltage | vs Time (start-up) | Figure 27 and Figure 28 |
| | | Equivalent series resistance (ESR) | vs Output current |

TPS70251
OUTPUT VOLTAGE
vs
OUTPUT CURRENT

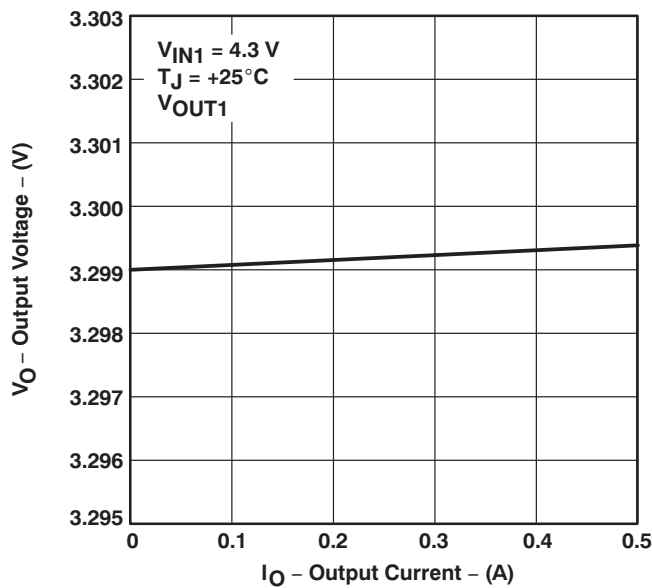

Figure 1.

TPS70251
OUTPUT VOLTAGE
vs
OUTPUT CURRENT

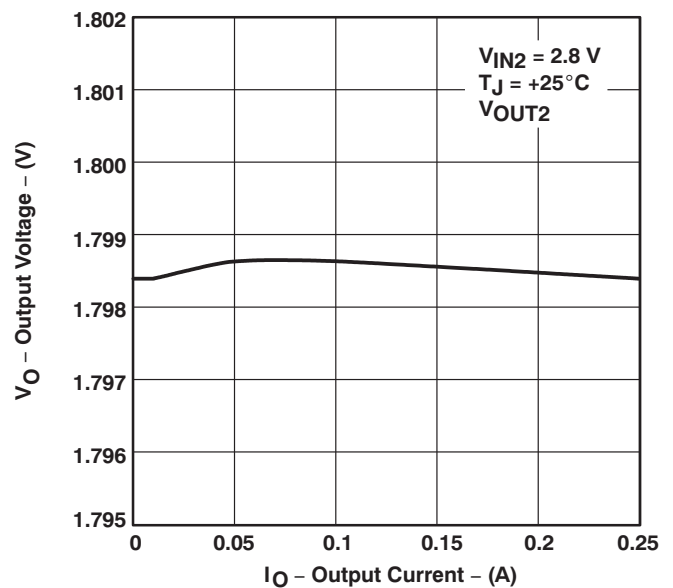

Figure 2.

TYPICAL CHARACTERISTICS (continued)

TPS70245
 OUTPUT VOLTAGE
 vs
 OUTPUT CURRENT

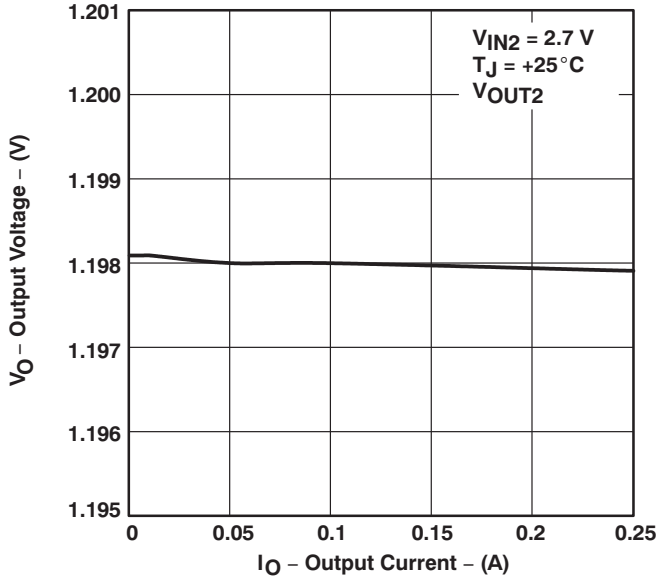

Figure 3.

TPS70251
 OUTPUT VOLTAGE
 vs
 JUNCTION TEMPERATURE

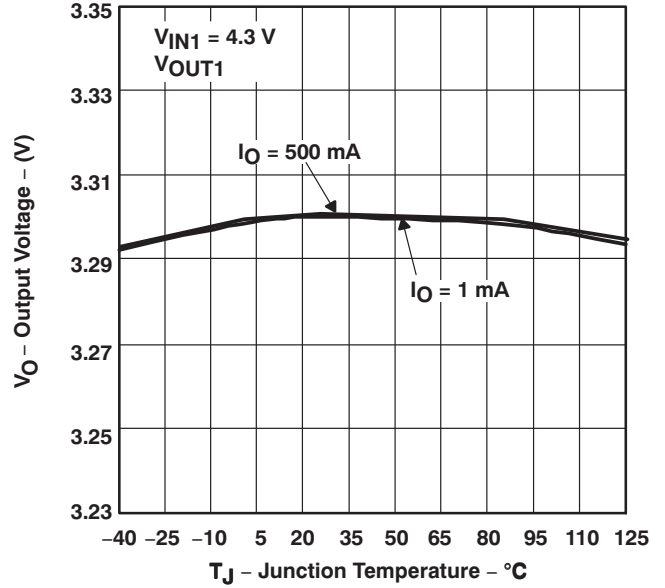

Figure 4.

TPS70251
 OUTPUT VOLTAGE
 vs
 JUNCTION TEMPERATURE

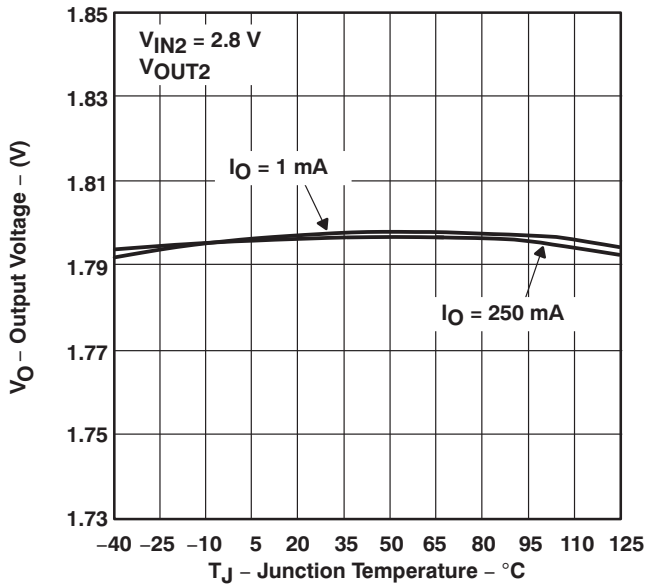

Figure 5.

GROUND CURRENT
 vs
 JUNCTION TEMPERATURE

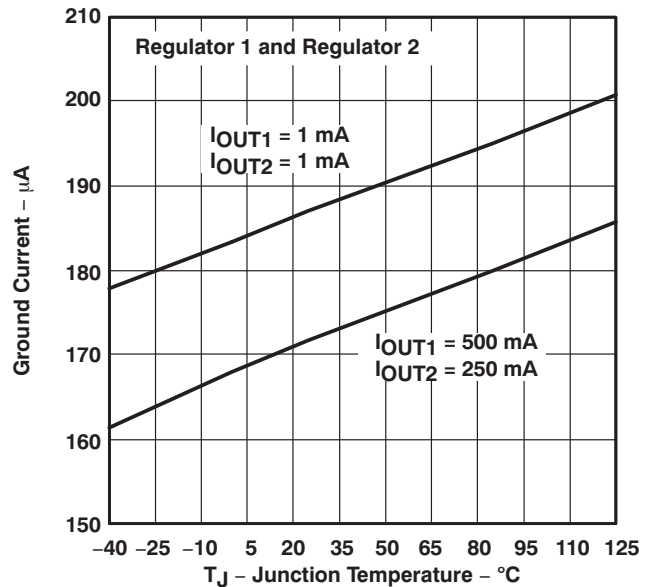

Figure 6.

TYPICAL CHARACTERISTICS (continued)

TPS70251
POWER-SUPPLY REJECTION RATIO
vs
FREQUENCY

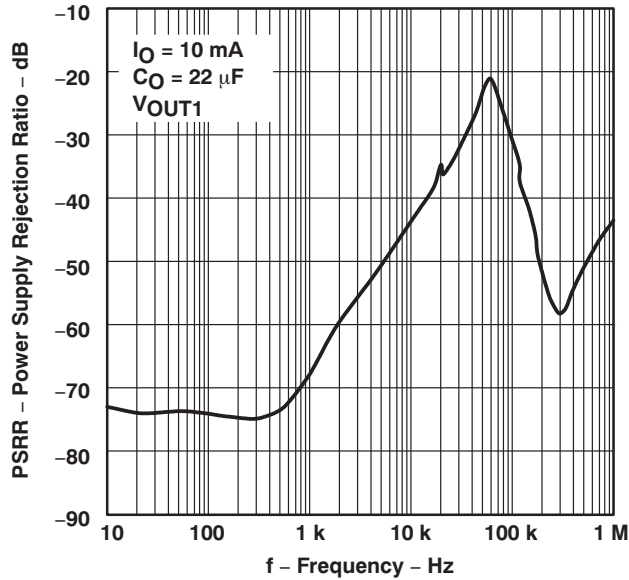

Figure 7.

TPS70251
POWER-SUPPLY REJECTION RATIO
vs
FREQUENCY

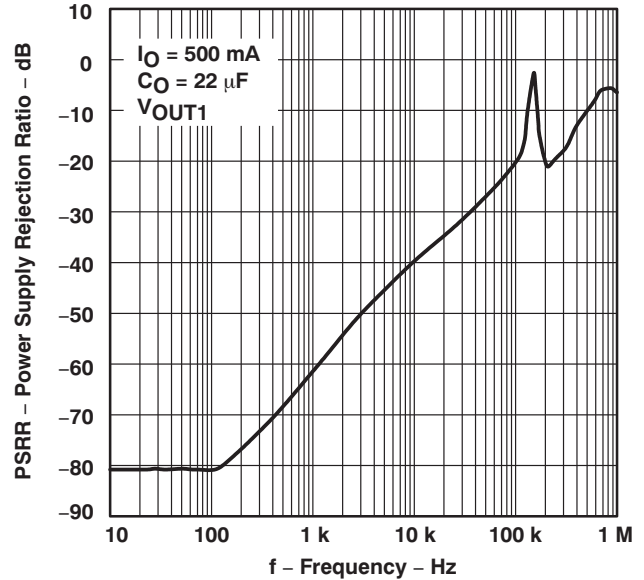

Figure 8.

TPS70251
POWER-SUPPLY REJECTION RATIO
vs
FREQUENCY

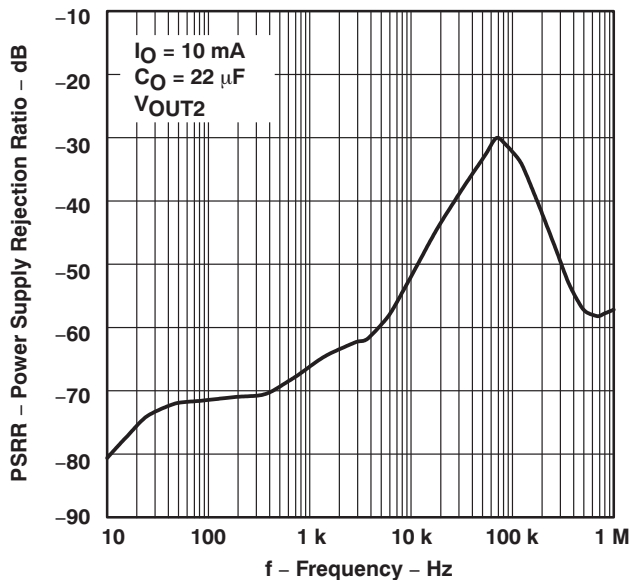

Figure 9.

TPS70251
POWER-SUPPLY REJECTION RATIO
vs
FREQUENCY

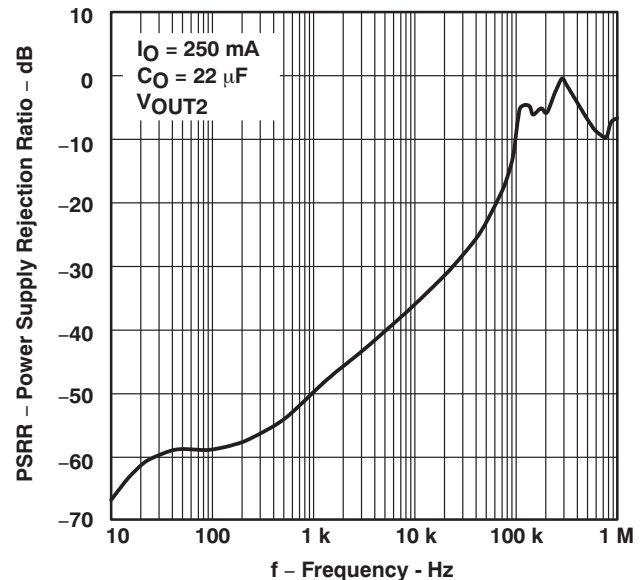

Figure 10.

TYPICAL CHARACTERISTICS (continued)

OUTPUT SPECTRAL NOISE DENSITY
 VS
 FREQUENCY

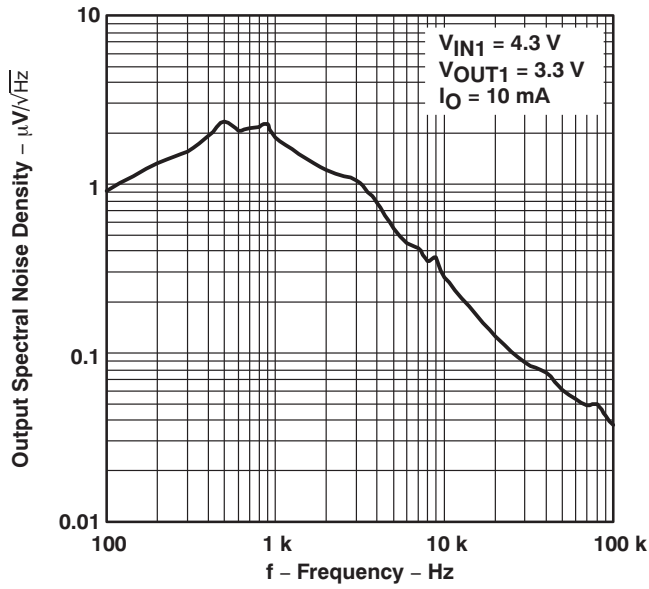

Figure 11.

OUTPUT SPECTRAL NOISE DENSITY
 VS
 FREQUENCY

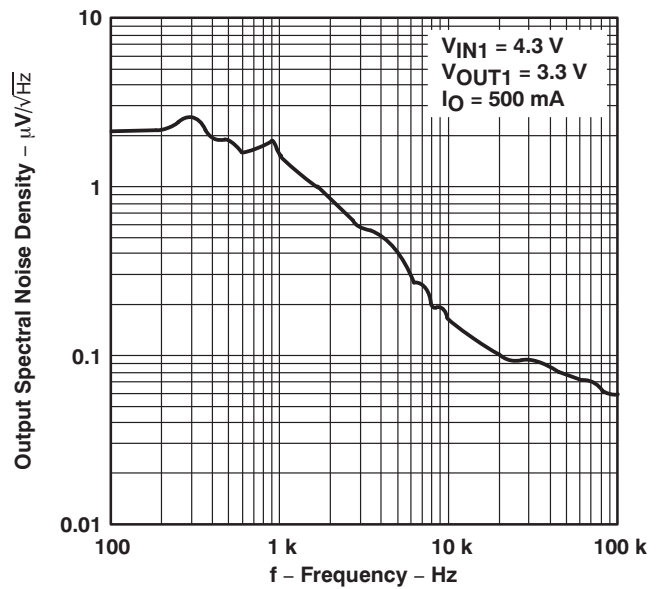

Figure 12.

OUTPUT SPECTRAL NOISE DENSITY
 VS
 FREQUENCY

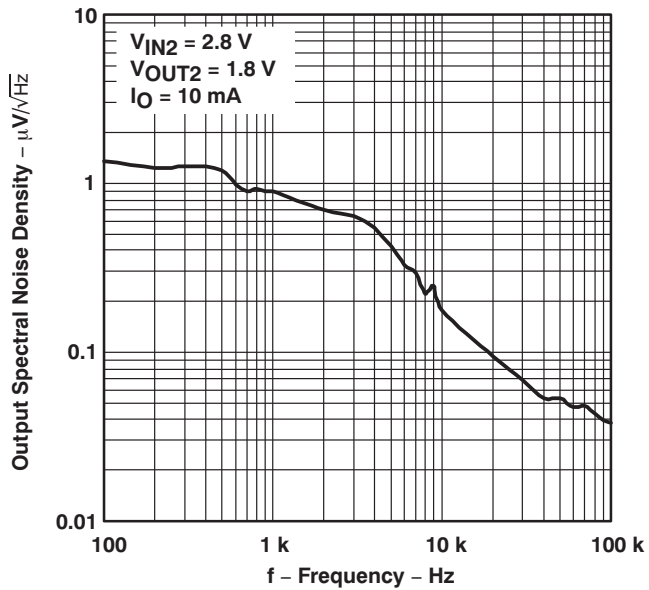

Figure 13.

OUTPUT SPECTRAL NOISE DENSITY
 VS
 FREQUENCY

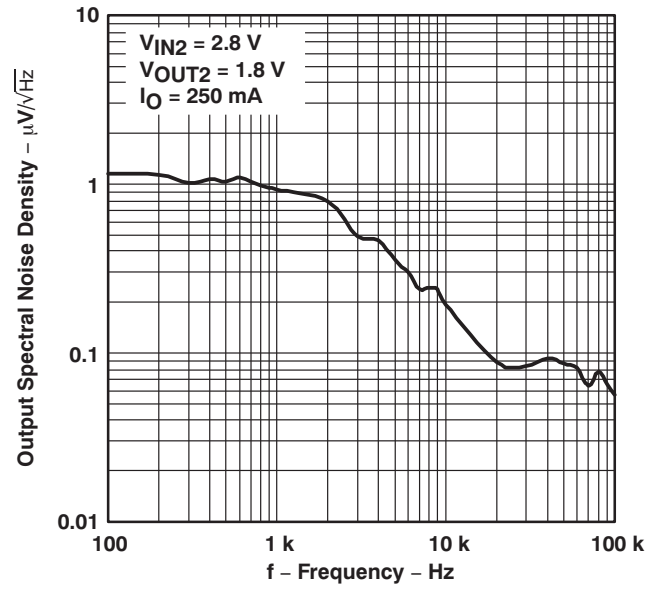

Figure 14.

TYPICAL CHARACTERISTICS (continued)

OUTPUT IMPEDANCE
vs
FREQUENCY

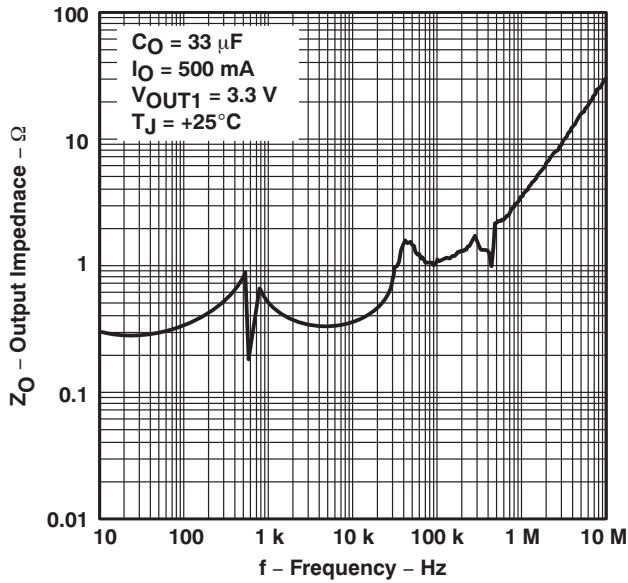

Figure 15.

OUTPUT IMPEDANCE
vs
FREQUENCY

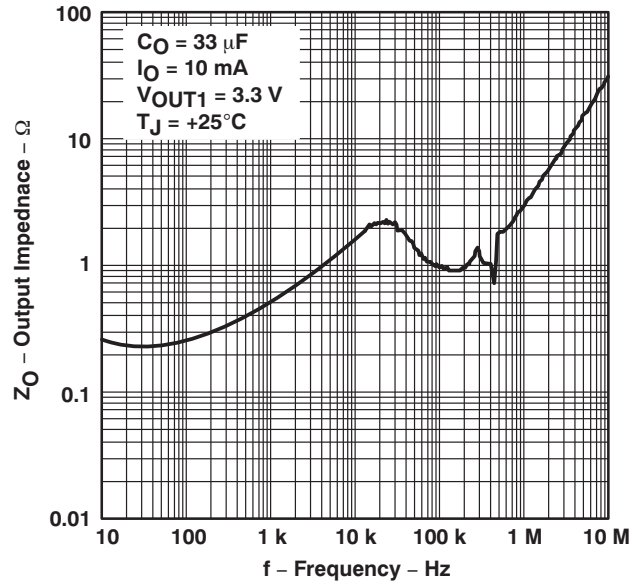

Figure 16.

OUTPUT IMPEDANCE
vs
FREQUENCY

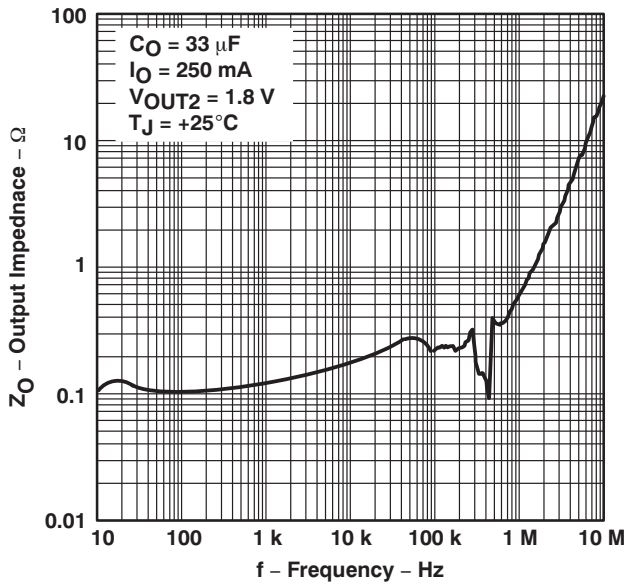

Figure 17.

OUTPUT IMPEDANCE
vs
FREQUENCY

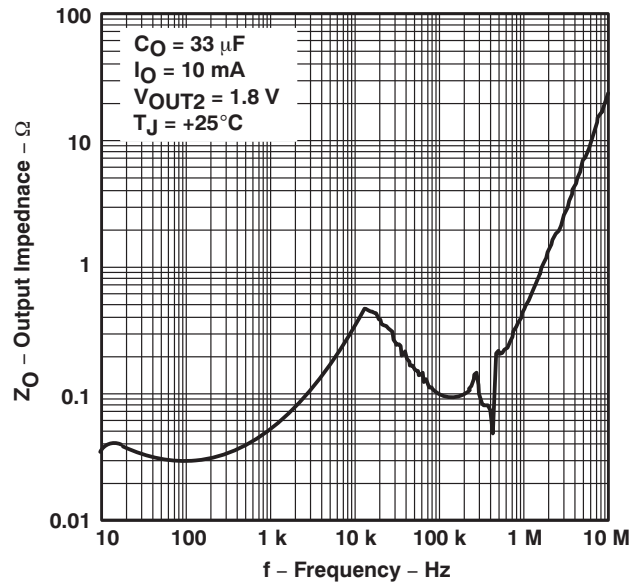

Figure 18.

TYPICAL CHARACTERISTICS (continued)

DROPOUT VOLTAGE
 vs
 TEMPERATURE

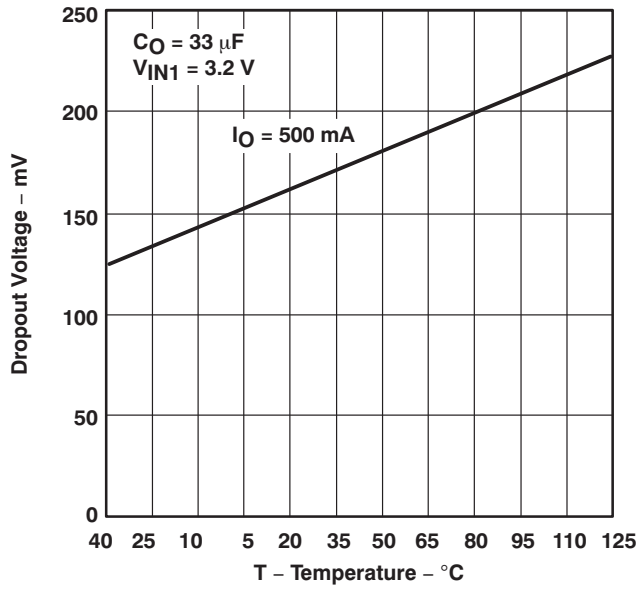

Figure 19.

DROPOUT VOLTAGE
 vs
 TEMPERATURE

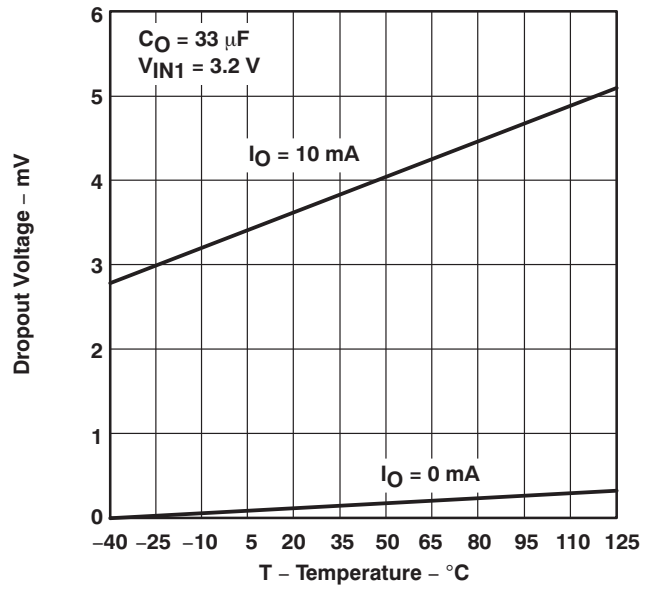

Figure 20.

TPS70202
 DROPOUT VOLTAGE
 vs
 INPUT VOLTAGE

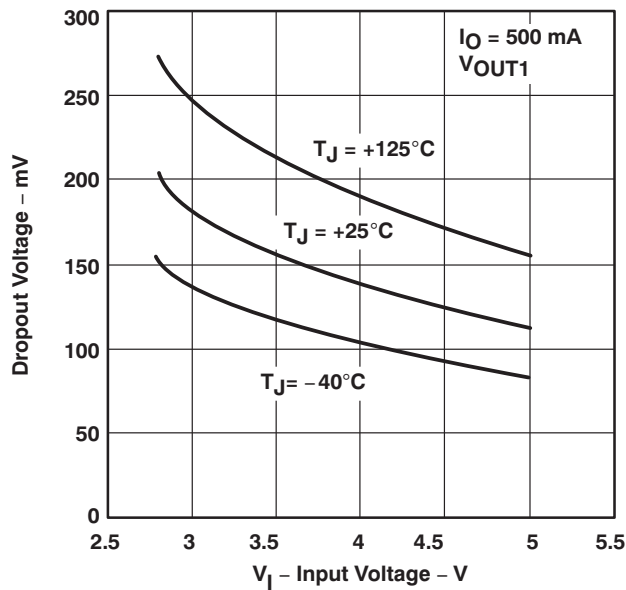

Figure 21.

TPS70202
 DROPOUT VOLTAGE
 vs
 INPUT VOLTAGE

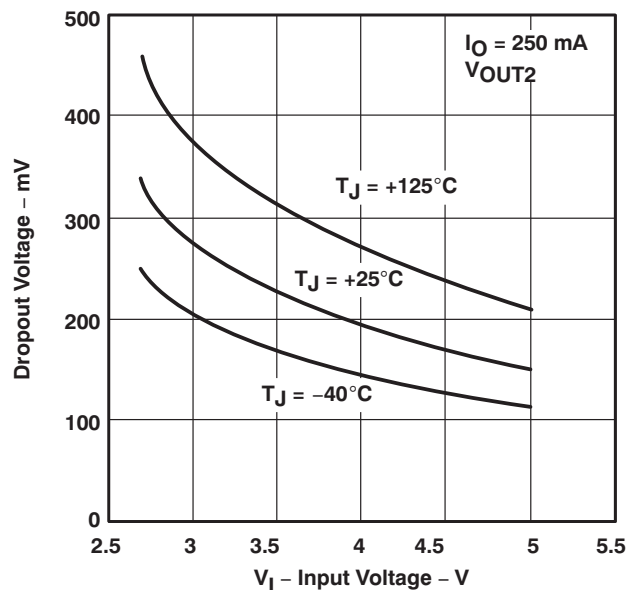

Figure 22.

TYPICAL CHARACTERISTICS (continued)

LOAD TRANSIENT RESPONSE

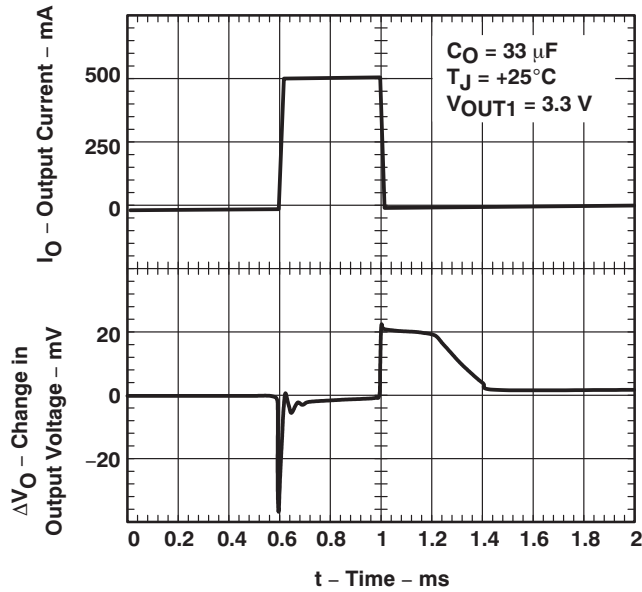

Figure 23.

LOAD TRANSIENT RESPONSE

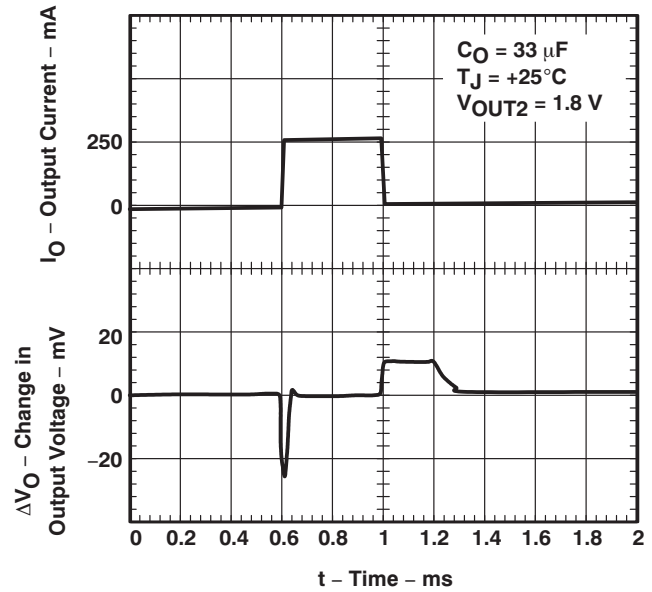

Figure 24.

LINE TRANSIENT RESPONSE

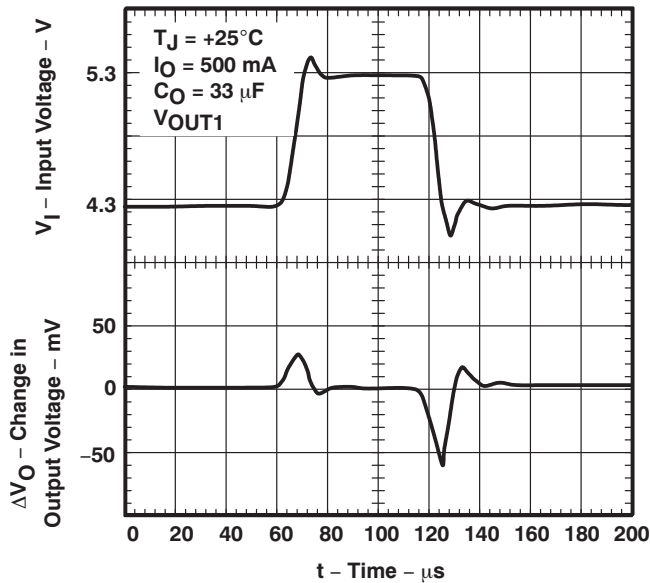

Figure 25.

LINE TRANSIENT RESPONSE

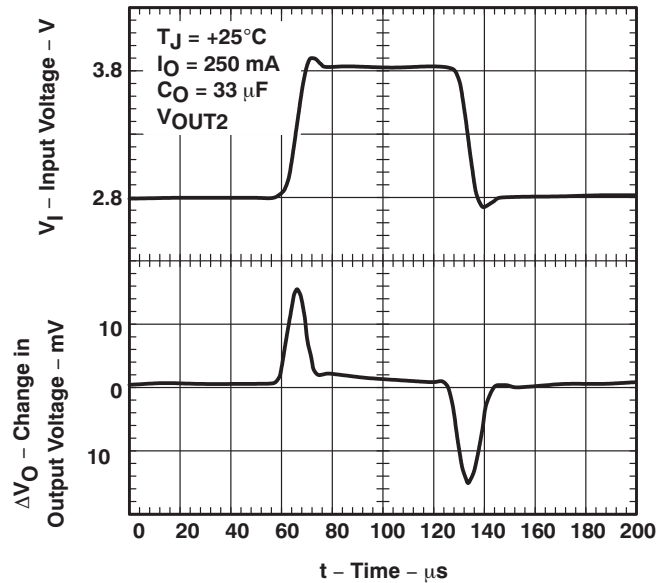

Figure 26.

TYPICAL CHARACTERISTICS (continued)

OUTPUT VOLTAGE AND ENABLE VOLTAGE
 VS
 TIME (START-UP)

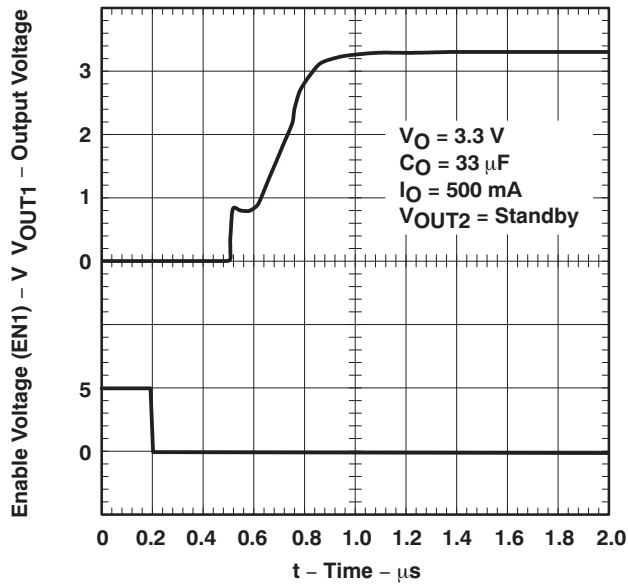

Figure 27.

OUTPUT VOLTAGE AND ENABLE VOLTAGE
 VS
 TIME (START-UP)

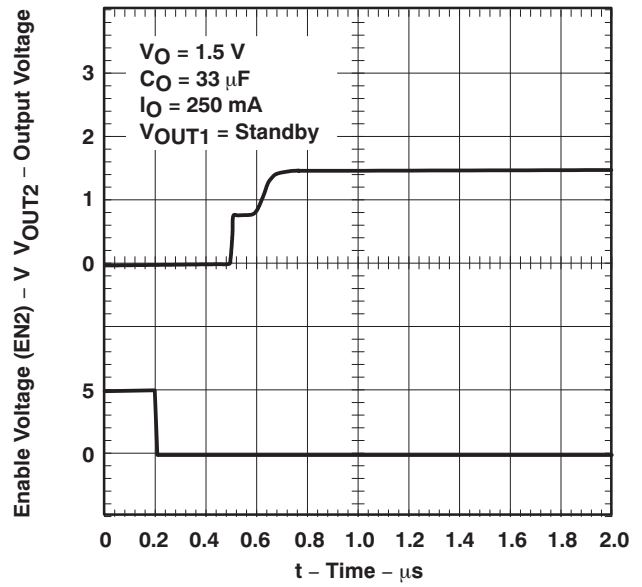

Figure 28.

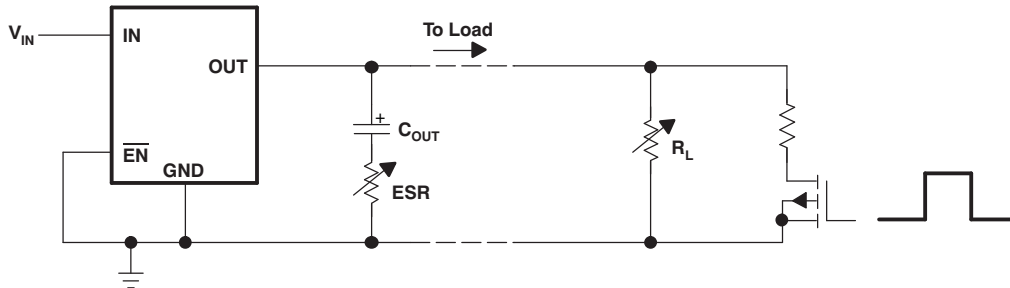

Figure 29. Test Circuit for Typical Regions of Stability

TYPICAL CHARACTERISTICS (continued)

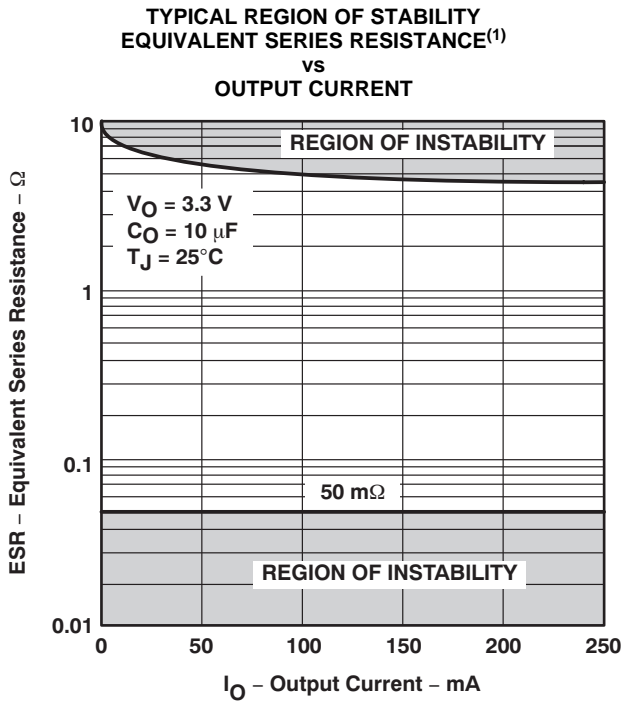

Figure 30.

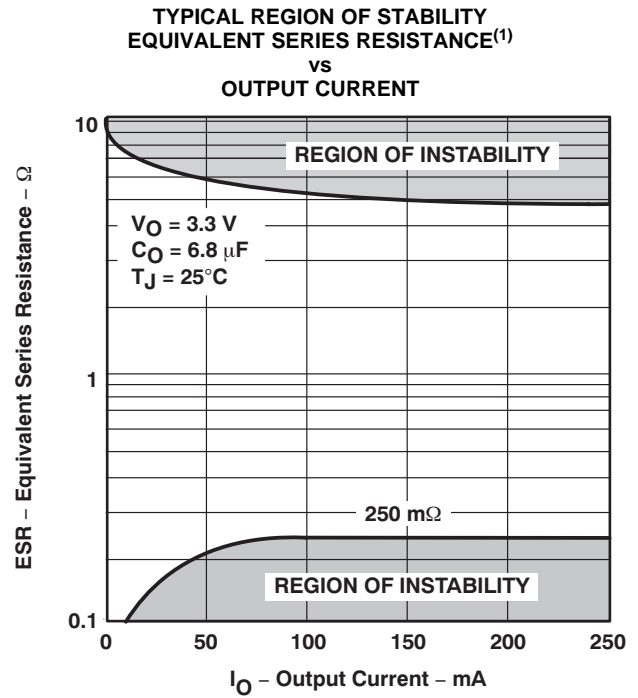

Figure 31.

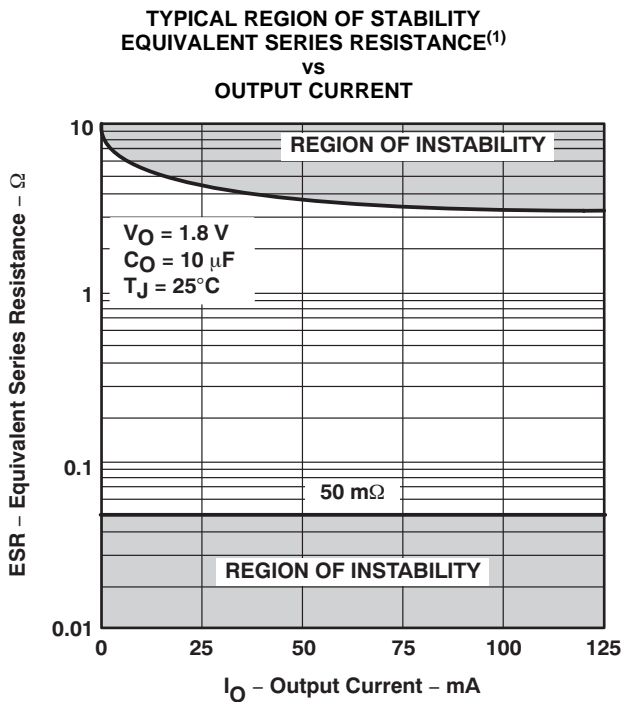

Figure 32.

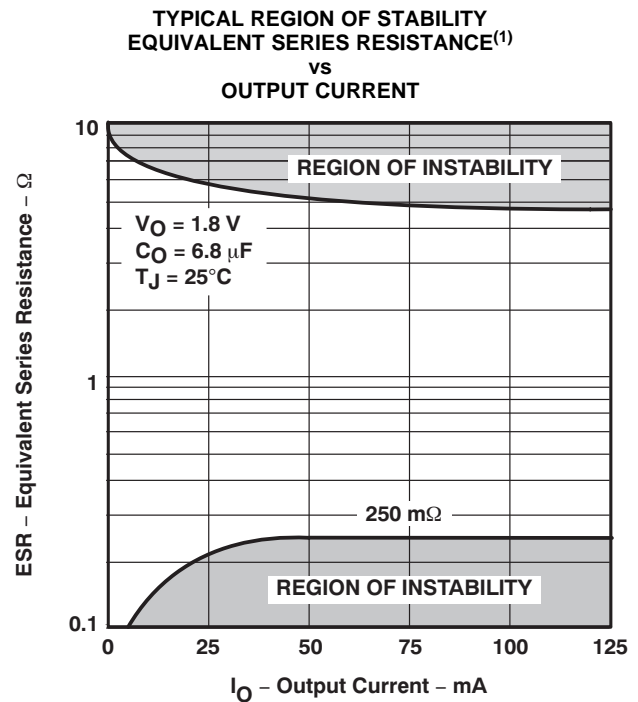

Figure 33.

⁽¹⁾ Equivalent series resistance (ESR) refers to the total series resistance, including the ESR of the capacitor, any series resistance added externally, and PWB trace resistance to C_O .

APPLICATION INFORMATION

Sequencing Timing Diagrams

This section provides a number of timing diagrams showing how this device functions in different configurations.

Application condition: V_{IN1} and V_{IN2} are tied to the same fixed input voltage greater than V_{UVLO} . $\overline{PG2}$ is tied to \overline{MR} .

$\overline{EN1}$ and $\overline{EN2}$ are initially high; therefore, both regulators are off, and $\overline{PG1}$ and $\overline{PG2}$ (tied to \overline{MR}) are at logic low. Since \overline{MR} is at logic low, \overline{RESET} is also at logic low. When $\overline{EN1}$ is taken to logic low, V_{OUT1} turns on. Later, when $\overline{EN2}$ is taken to logic low, V_{OUT2} turns on. When V_{OUT1} reaches 95% of its regulated output voltage, $\overline{PG1}$ goes to logic high. When V_{OUT2} reaches 95% of its regulated output voltage, $\overline{PG2}$ (tied to \overline{MR}) goes to logic high. When V_{IN1} is greater than V_{UVLO} and \overline{MR} (tied to $\overline{PG2}$) is at logic high, \overline{RESET} is pulled to logic high after a 120ms delay. When $\overline{EN1}$ and $\overline{EN2}$ are returned to logic high, both devices power down and both $\overline{PG1}$, $\overline{PG2}$ (tied to $\overline{MR2}$), and \overline{RESET} return to logic low.

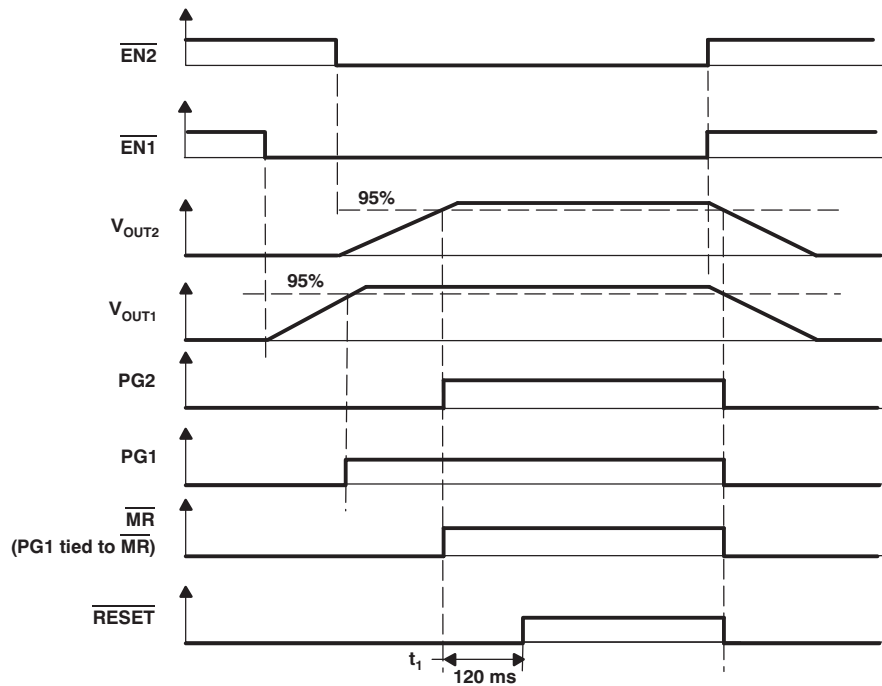
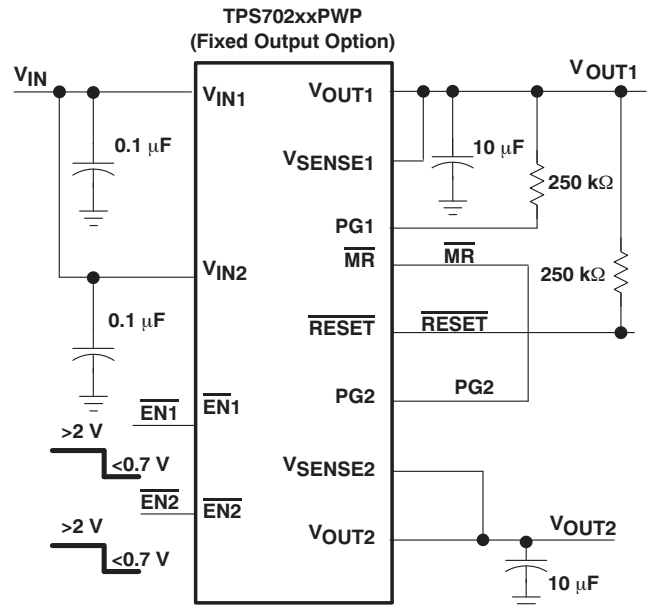

NOTES: A. t_1 : Time at which V_{IN} is greater than V_{UVLO} and \overline{MR} is logic high.
 B. The timing diagram is not drawn to scale.

Figure 34. Timing When V_{OUT1} Is Enabled Before V_{OUT2}

Application condition: V_{IN1} and V_{IN2} are tied to the same fixed input voltage greater than V_{UVLO} . \overline{MR} is initially logic high but is eventually toggled.

$\overline{EN1}$ and $\overline{EN2}$ are initially high; therefore, both regulators are off, and PG1 and PG2 are at logic low. Since V_{IN1} is greater than V_{UVLO} and \overline{MR} is at logic high, \overline{RESET} is also at logic high. When $\overline{EN2}$ is taken to logic low, V_{OUT2} turns on. Later, when $\overline{EN1}$ is taken to logic low, V_{OUT1} turns on. When V_{OUT2} reaches 95% of its regulated output voltage, PG2 goes to logic high. When V_{OUT1} reaches 95% of its regulated output voltage, PG1 goes to logic high. When \overline{MR} is taken to logic low, \overline{RESET} is taken low. When \overline{MR} returns to logic high, \overline{RESET} returns to logic high after a 120ms delay.

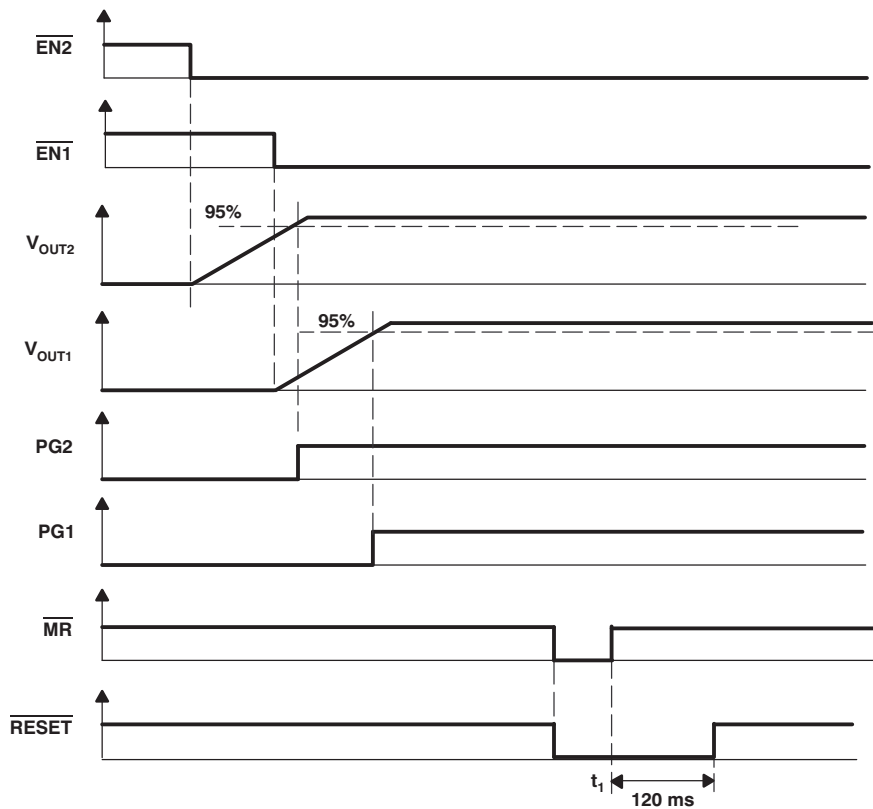
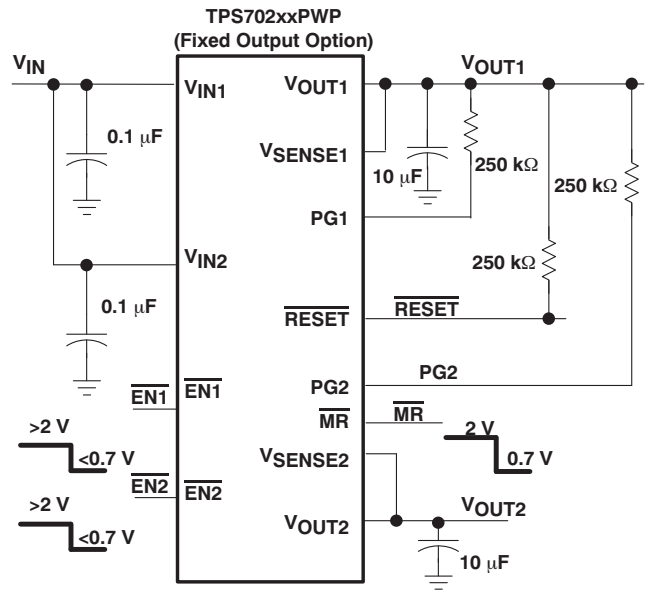

NOTES: A. t_1 : Time at which V_{IN} is greater than V_{UVLO} and \overline{MR} is logic high.
B. The timing diagram is not drawn to scale.

Figure 35. Timing When \overline{MR} is Toggled

Application condition: V_{IN1} and V_{IN2} are tied to same fixed input voltage greater than V_{UVLO} . $\overline{PG1}$ is tied to \overline{MR} .

$\overline{EN1}$ and $\overline{EN2}$ are initially high; therefore, both regulators are off, and $\overline{PG1}$ (tied to \overline{MR}) and $\overline{PG2}$ are at logic low. Since \overline{MR} is at logic low, \overline{RESET} is also at logic low. When $\overline{EN2}$ is taken to logic low, V_{OUT2} turns on. Later, when $\overline{EN1}$ is taken to logic low, V_{OUT1} turns on. When V_{OUT2} reaches 95% of its regulated output voltage, $\overline{PG2}$ goes to logic high. When V_{OUT1} reaches 95% of its regulated output voltage, $\overline{PG1}$ goes to logic high. When V_{IN1} is greater than V_{UVLO} and \overline{MR} (tied to $\overline{PG2}$) is at logic high, \overline{RESET} is pulled to logic high after a 120ms delay. When a fault on V_{OUT1} causes it to fall below 95% of its regulated output voltage, $\overline{PG1}$ (tied to \overline{MR}) goes to logic low. Since \overline{MR} is logic low, \overline{RESET} goes to logic low. V_{OUT2} is unaffected.

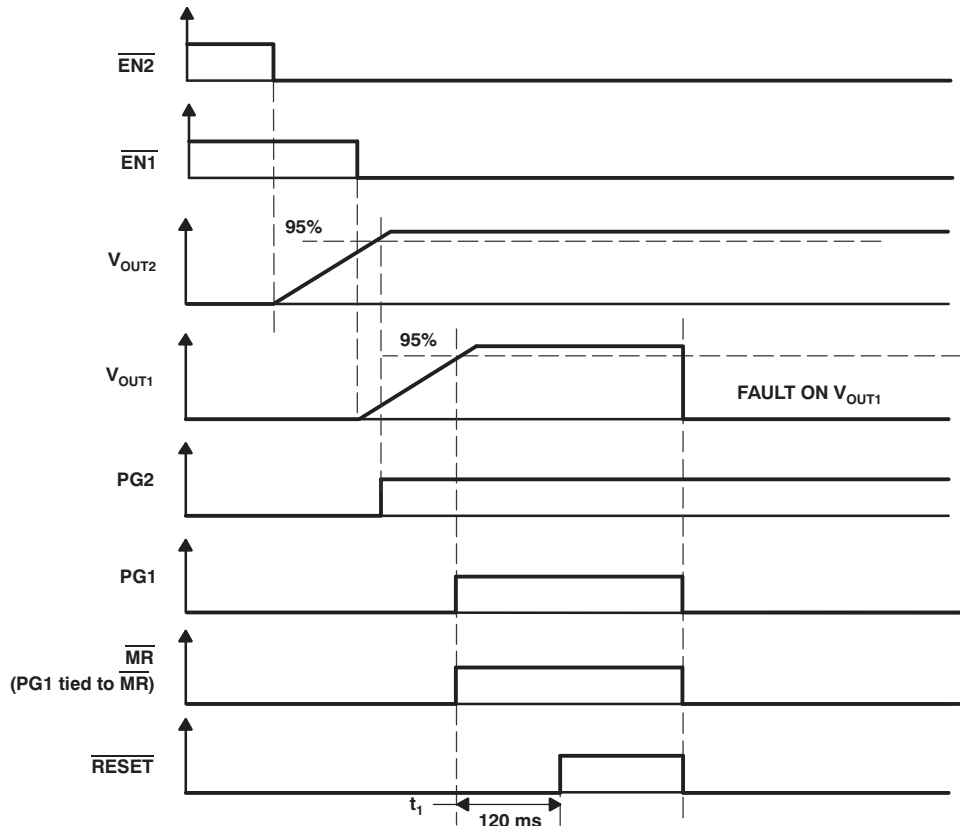
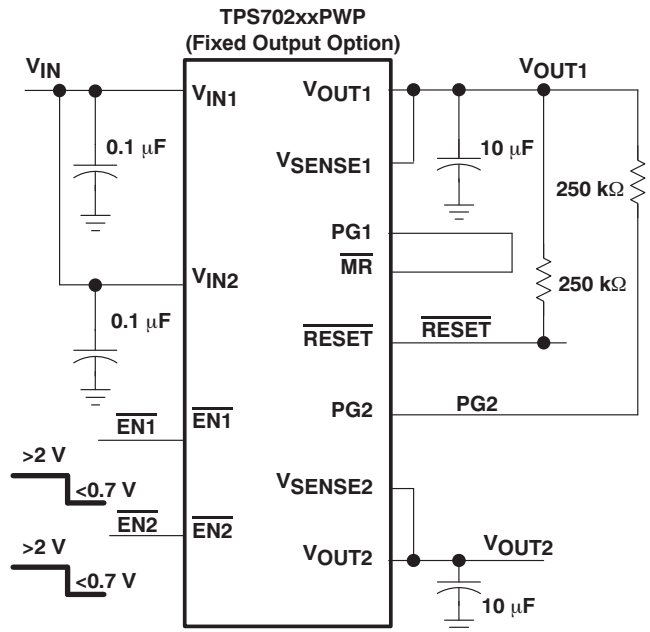

NOTES: A. t_1 : Time at which V_{IN} is greater than V_{UVLO} and \overline{MR} is logic high.
 B. The timing diagram is not drawn to scale.

Figure 36. Timing When V_{OUT1} Faults Out

APPLICATION INFORMATION

Input Capacitor

For a typical application, an input bypass capacitor (0.1 μ F to 1 μ F) is recommended. This capacitor filters any high-frequency noise generated in the line. For fast transient conditions where droop at the input of the LDO may occur because of high inrush current, it is recommended to place a larger capacitor at the input as well. The size of this capacitor depends on the output current and response time of the main power supply, as well as the distance to the V_I pins of the LDO.

Output Capacitor

As with most LDO regulators, the TPS702xx requires an output capacitor connected between OUT and GND to stabilize the internal control loop. The minimum recommended capacitance values are 10 μ F ceramic capacitors with an ESR (equivalent series resistance) between 50m Ω and 2.5 Ω or 6.8 μ F tantalum capacitors with ESR between 250m Ω and 4 Ω . Solid tantalum electrolytic, aluminum electrolytic, and multilayer ceramic capacitors with capacitance values greater than 10 μ F are all suitable, provided they meet the requirements described above. Larger capacitors provide a wider range of stability and better load transient response. [Table 1](#) gives a partial listing of surface-mount capacitors suitable for use with the TPS702xx for fast transient response applications.

This information, along with the ESR graphs, is included to assist in selection of suitable capacitance for user applications. When necessary to achieve low height requirements along with high output current and/or high load capacitance, several higher ESR capacitors can be used in parallel to meet the guidelines above.

Table 1. Partial Listing of TPS702xx-Compatible Surface-Mount Capacitors

| VALUE | MANUFACTURER | MAXIMUM ESR | MFR PART NO. |
|------------|--------------|---------------|-----------------|
| 22 μ F | Kemet | 345m Ω | 7495C226K0010AS |
| 33 μ F | Sanyo | 100m Ω | 10TPA33M |
| 47 μ F | Sanyo | 100m Ω | 6TPA47M |
| 68 μ F | Sanyo | 45m Ω | 10TPC68M |

ESR and Transient Response

LDOs typically require an external output capacitor for stability. In fast transient response applications, capacitors are used to support the load current while the LDO amplifier is responding. In most applications, one capacitor is used to support both functions.

Besides its capacitance, every capacitor also contains parasitic impedances. These parasitic impedances are resistive as well as inductive. The resistive impedance is called *equivalent series resistance* (ESR), and the inductive impedance is called *equivalent series inductance* (ESL). The equivalent schematic diagram of any capacitor can therefore be drawn as shown in [Figure 37](#).



Figure 37. ESR and ESL

In most cases one can neglect the effect of inductive impedance ESL. Therefore, the following application focuses mainly on the parasitic resistance ESR.

Figure 38 shows the output capacitor and its parasitic impedances in a typical LDO output stage.

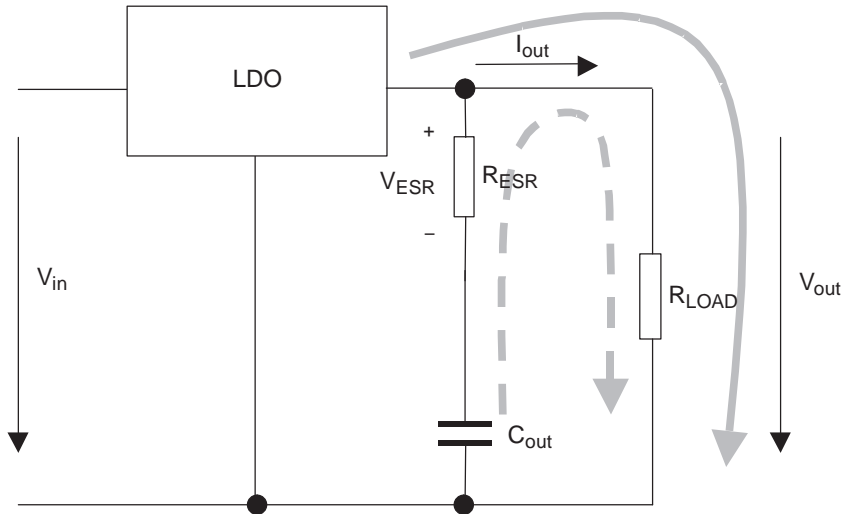

Figure 38. LDO Output Stage with Parasitic Resistances ESR

In steady state (dc state condition), the load current is supplied by the LDO (solid arrow) and the voltage across the capacitor is the same as the output voltage ($V_{(CO)} = V_{OUT}$). This condition means no current is flowing into the C_{OUT} branch. If I_{OUT} suddenly increases (a transient condition), the following results occur:

- The LDO is not able to supply the sudden current need because of its response time (t_1 in Figure 39). Therefore, capacitor C_{OUT} provides the current for the new load condition (dashed arrow). C_{OUT} now acts like a battery with an internal resistance, ESR. Depending on the current demand at the output, a voltage drop occurs at R_{ESR} . This voltage is shown as V_{ESR} in Figure 38.
- When C_{OUT} is conducting current to the load, initial voltage at the load will be $V_{OUT} = V_{(CO)} - V_{ESR}$. As a result of the discharge of C_{OUT} , the output voltage V_{OUT} drops continuously until the response time t_1 of the LDO is reached and the LDO resumes supplying the load. From this point, the output voltage starts rising again until it reaches the regulated voltage. This period is shown as t_2 in Figure 39.

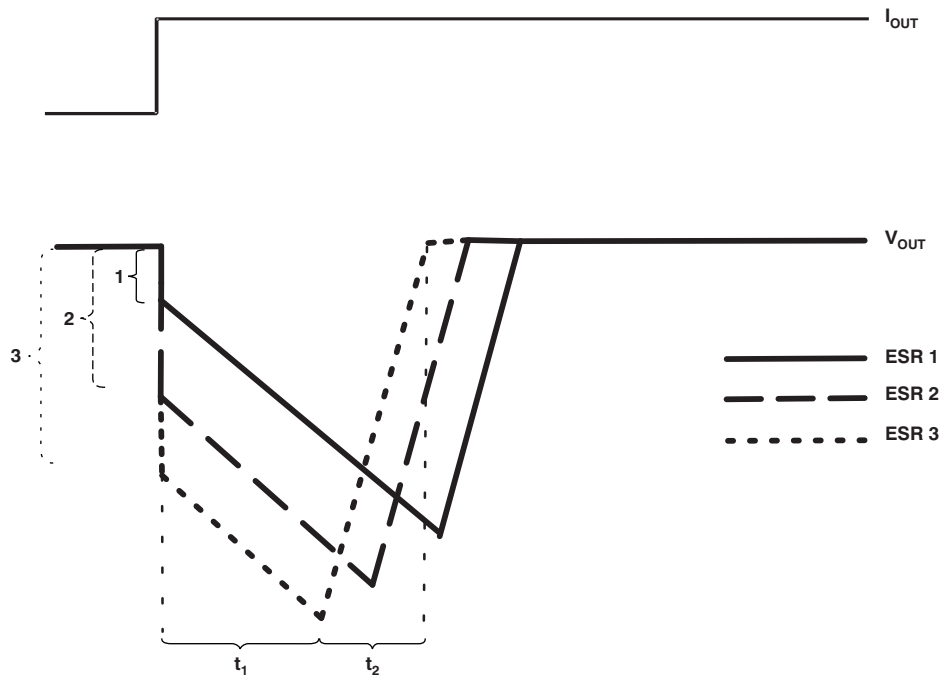

Figure 39. Correlation of Different ESRs and Their Influence on the Regulation of V_O at a Load Step from Low-to-High Output Current

Figure 39 also shows the impact of different ESRs on the output voltage. The left brackets show different levels of ESRs where number 1 displays the lowest and number 3 displays the highest ESR.

From above, the following conclusions can be drawn:

- The higher the ESR, the larger the droop at the beginning of the load transient.
- The smaller the output capacitor, the faster the discharge time and the greater the voltage droop during the LDO response period.

Conclusion

To minimize the transient output droop, capacitors must have a low ESR and be large enough to support the minimum output voltage requirement.

Programming the TPS70202 Adjustable LDO Regulator

The output voltage of the TPS70202 adjustable regulators is programmed using external resistor dividers as shown in Figure 40.

Resistors R1 and R2 should be chosen for approximately a 50µA divider current. Lower value resistors can be used, but offer no inherent advantage and waste more power. Higher values should be avoided as leakage currents at the sense terminal increase the output voltage error. The recommended design procedure is to choose R2 = 30.1kΩ to set the divider current at approximately 50µA, and then calculate R1 using Equation 1:

$$R1 = \left(\frac{V_{OUT}}{V_{REF}} - 1 \right) \times R2 \quad (1)$$

where:

- $V_{REF} = 1.224V$ typ (the internal reference voltage)

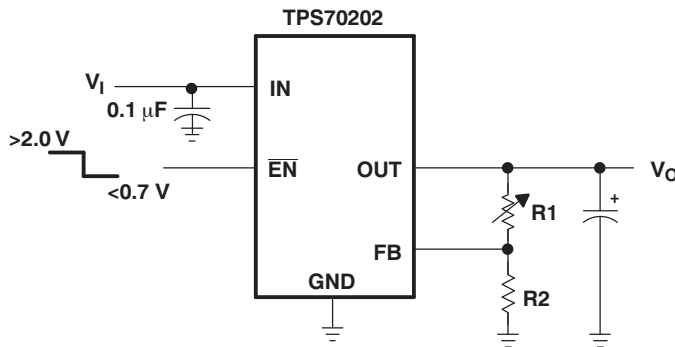

OUTPUT VOLTAGE
 PROGRAMMING GUIDE

| OUTPUT VOLTAGE | R1 | R2 | UNIT |
|----------------|------|------|------|
| 2.5 V | 31.6 | 30.1 | kΩ |
| 3.3 V | 51.1 | 30.1 | kΩ |
| 3.6 V | 59.0 | 30.1 | kΩ |

Figure 40. TPS70202 Adjustable LDO Regulator Programming

Regulator Protection

Both TPS702xx PMOS-pass transistors have built-in back diodes that conduct reverse currents when the input voltage drops below the output voltage (for example, during power-down). Current is conducted from the output to the input and is not internally limited. When extended reverse voltage is anticipated, external limiting may be appropriate.

The TPS702xx also features internal current limiting and thermal protection. During normal operation, the TPS702xx regulator 1 limits output current to approximately 1.6A (typ) and regulator 2 limits output current to approximately 750mA (typ). When current limiting engages, the output voltage scales back linearly until the overcurrent condition ends. While current limiting is designed to prevent gross device failure, care should be taken not to exceed the power dissipation ratings of the package. If the temperature of the device exceeds +150°C (typ), thermal-protection circuitry shuts it down. Once the device has cooled below +130°C (typ), regulator operation resumes.

Power Dissipation and Junction Temperature

Specified regulator operation is assured to a junction temperature of +125°C; the maximum junction temperature should be restricted to +125°C under normal operating conditions. This restriction limits the power dissipation the regulator can handle in any given application. To ensure the junction temperature is within acceptable limits, calculate the maximum allowable dissipation, $P_{D(max)}$, and the actual dissipation, P_D , which must be less than or equal to $P_{D(max)}$.

The maximum-power-dissipation limit is determined using [Equation 2](#):

$$P_{D(max)} = \frac{T_{Jmax} - T_A}{R_{\theta JA}} \quad (2)$$

where:

- T_{Jmax} is the maximum allowable junction temperature
- $R_{\theta JA}$ is the thermal resistance junction-to-ambient for the package; that is, 32.6°C/W for the 20-terminal PWP with no airflow
- T_A is the ambient temperature

The regulator dissipation is calculated using [Equation 3](#):

$$P_D = (V_I - V_O) \times I_O \quad (3)$$

Power dissipation resulting from quiescent current is negligible. Excessive power dissipation triggers the thermal protection circuit.

REVISION HISTORY

NOTE: Page numbers for previous revisions may differ from page numbers in the current version.

| Changes from Revision D (December, 2007) to Revision E | Page |
|---|------|
| • Corrected typo in <i>output current limit</i> specification units | 5 |
| • Deleted <i>falling edge delay</i> specification | 6 |
| • Updated <i>Fixed Voltage Version</i> block diagram | 7 |
| • Updated <i>Adjustable Voltage Version</i> block diagram | 8 |

PACKAGING INFORMATION

| Orderable Device | Status (1) | Package Type | Package Drawing | Pins | Package Qty | Eco Plan (2) | Lead/Ball Finish (6) | MSL Peak Temp (3) | Op Temp (°C) | Device Marking (4/5) | Samples |
|------------------|---------------|--------------|-----------------|------|-------------|-------------------------|-------------------------|----------------------|--------------|-------------------------|-------------------------|
| TPS70202PWP | ACTIVE | HTSSOP | PWP | 20 | 70 | Green (RoHS & no Sb/Br) | CU NIPDAU | Level-2-260C-1 YEAR | -40 to 125 | PT70202 | Samples |
| TPS70202PWPG4 | ACTIVE | HTSSOP | PWP | 20 | 70 | Green (RoHS & no Sb/Br) | CU NIPDAU | Level-2-260C-1 YEAR | -40 to 125 | PT70202 | Samples |
| TPS70202PWPR | ACTIVE | HTSSOP | PWP | 20 | 2000 | Green (RoHS & no Sb/Br) | CU NIPDAU | Level-2-260C-1 YEAR | -40 to 125 | PT70202 | Samples |
| TPS70202PWPRG4 | ACTIVE | HTSSOP | PWP | 20 | 2000 | Green (RoHS & no Sb/Br) | CU NIPDAU | Level-2-260C-1 YEAR | -40 to 125 | PT70202 | Samples |
| TPS70245PWP | ACTIVE | HTSSOP | PWP | 20 | 70 | Green (RoHS & no Sb/Br) | CU NIPDAU | Level-2-260C-1 YEAR | -40 to 125 | PT70245 | Samples |
| TPS70245PWPR | ACTIVE | HTSSOP | PWP | 20 | 2000 | Green (RoHS & no Sb/Br) | CU NIPDAU | Level-2-260C-1 YEAR | -40 to 125 | PT70245 | Samples |
| TPS70248PWP | ACTIVE | HTSSOP | PWP | 20 | 70 | Green (RoHS & no Sb/Br) | CU NIPDAU | Level-2-260C-1 YEAR | -40 to 125 | PT70248 | Samples |
| TPS70248PWPR | ACTIVE | HTSSOP | PWP | 20 | 2000 | Green (RoHS & no Sb/Br) | CU NIPDAU | Level-2-260C-1 YEAR | -40 to 125 | PT70248 | Samples |
| TPS70251PWP | ACTIVE | HTSSOP | PWP | 20 | 70 | Green (RoHS & no Sb/Br) | CU NIPDAU | Level-2-260C-1 YEAR | -40 to 125 | PT70251 | Samples |
| TPS70251PWPR | ACTIVE | HTSSOP | PWP | 20 | 2000 | Green (RoHS & no Sb/Br) | CU NIPDAU | Level-2-260C-1 YEAR | -40 to 125 | PT70251 | Samples |
| TPS70251PWPRG4 | ACTIVE | HTSSOP | PWP | 20 | 2000 | Green (RoHS & no Sb/Br) | CU NIPDAU | Level-2-260C-1 YEAR | -40 to 125 | PT70251 | Samples |
| TPS70258PWP | ACTIVE | HTSSOP | PWP | 20 | 70 | Green (RoHS & no Sb/Br) | CU NIPDAU | Level-2-260C-1 YEAR | -40 to 125 | PT70258 | Samples |
| TPS70258PWPR | ACTIVE | HTSSOP | PWP | 20 | 2000 | Green (RoHS & no Sb/Br) | CU NIPDAU | Level-2-260C-1 YEAR | -40 to 125 | PT70258 | Samples |

(1) The marketing status values are defined as follows:

ACTIVE: Product device recommended for new designs.

LIFEBUY: TI has announced that the device will be discontinued, and a lifetime-buy period is in effect.

NRND: Not recommended for new designs. Device is in production to support existing customers, but TI does not recommend using this part in a new design.

PREVIEW: Device has been announced but is not in production. Samples may or may not be available.

OBSOLETE: TI has discontinued the production of the device.

(2) **RoHS:** TI defines "RoHS" to mean semiconductor products that are compliant with the current EU RoHS requirements for all 10 RoHS substances, including the requirement that RoHS substance do not exceed 0.1% by weight in homogeneous materials. Where designed to be soldered at high temperatures, "RoHS" products are suitable for use in specified lead-free processes. TI may reference these types of products as "Pb-Free".

RoHS Exempt: TI defines "RoHS Exempt" to mean products that contain lead but are compliant with EU RoHS pursuant to a specific EU RoHS exemption.

Green: TI defines "Green" to mean the content of Chlorine (Cl) and Bromine (Br) based flame retardants meet JS709B low halogen requirements of ≤ 1000 ppm threshold. Antimony trioxide based flame retardants must also meet the ≤ 1000 ppm threshold requirement.

(3) MSL, Peak Temp. - The Moisture Sensitivity Level rating according to the JEDEC industry standard classifications, and peak solder temperature.

(4) There may be additional marking, which relates to the logo, the lot trace code information, or the environmental category on the device.

(5) Multiple Device Markings will be inside parentheses. Only one Device Marking contained in parentheses and separated by a "~" will appear on a device. If a line is indented then it is a continuation of the previous line and the two combined represent the entire Device Marking for that device.

(6) Lead/Ball Finish - Orderable Devices may have multiple material finish options. Finish options are separated by a vertical ruled line. Lead/Ball Finish values may wrap to two lines if the finish value exceeds the maximum column width.

Important Information and Disclaimer: The information provided on this page represents TI's knowledge and belief as of the date that it is provided. TI bases its knowledge and belief on information provided by third parties, and makes no representation or warranty as to the accuracy of such information. Efforts are underway to better integrate information from third parties. TI has taken and continues to take reasonable steps to provide representative and accurate information but may not have conducted destructive testing or chemical analysis on incoming materials and chemicals. TI and TI suppliers consider certain information to be proprietary, and thus CAS numbers and other limited information may not be available for release.

In no event shall TI's liability arising out of such information exceed the total purchase price of the TI part(s) at issue in this document sold by TI to Customer on an annual basis.

TAPE AND REEL INFORMATION

QUADRANT ASSIGNMENTS FOR PIN 1 ORIENTATION IN TAPE

*All dimensions are nominal

| Device | Package Type | Package Drawing | Pins | SPQ | Reel Diameter (mm) | Reel Width W1 (mm) | A0 (mm) | B0 (mm) | K0 (mm) | P1 (mm) | W (mm) | Pin1 Quadrant |
|--------------|--------------|-----------------|------|------|--------------------|--------------------|---------|---------|---------|---------|--------|---------------|
| TPS70202PWPR | HTSSOP | PWP | 20 | 2000 | 330.0 | 16.4 | 6.95 | 7.1 | 1.6 | 8.0 | 16.0 | Q1 |
| TPS70245PWPR | HTSSOP | PWP | 20 | 2000 | 330.0 | 16.4 | 6.95 | 7.1 | 1.6 | 8.0 | 16.0 | Q1 |
| TPS70248PWPR | HTSSOP | PWP | 20 | 2000 | 330.0 | 16.4 | 6.95 | 7.1 | 1.6 | 8.0 | 16.0 | Q1 |
| TPS70251PWPR | HTSSOP | PWP | 20 | 2000 | 330.0 | 16.4 | 6.95 | 7.1 | 1.6 | 8.0 | 16.0 | Q1 |
| TPS70258PWPR | HTSSOP | PWP | 20 | 2000 | 330.0 | 16.4 | 6.95 | 7.1 | 1.6 | 8.0 | 16.0 | Q1 |

TAPE AND REEL BOX DIMENSIONS



*All dimensions are nominal

| Device | Package Type | Package Drawing | Pins | SPQ | Length (mm) | Width (mm) | Height (mm) |
|--------------|--------------|-----------------|------|------|-------------|------------|-------------|
| TPS70202PWPR | HTSSOP | PWP | 20 | 2000 | 350.0 | 350.0 | 43.0 |
| TPS70245PWPR | HTSSOP | PWP | 20 | 2000 | 350.0 | 350.0 | 43.0 |
| TPS70248PWPR | HTSSOP | PWP | 20 | 2000 | 350.0 | 350.0 | 43.0 |
| TPS70251PWPR | HTSSOP | PWP | 20 | 2000 | 350.0 | 350.0 | 43.0 |
| TPS70258PWPR | HTSSOP | PWP | 20 | 2000 | 350.0 | 350.0 | 43.0 |

MECHANICAL DATA

PWP (R-PDSO-G20)

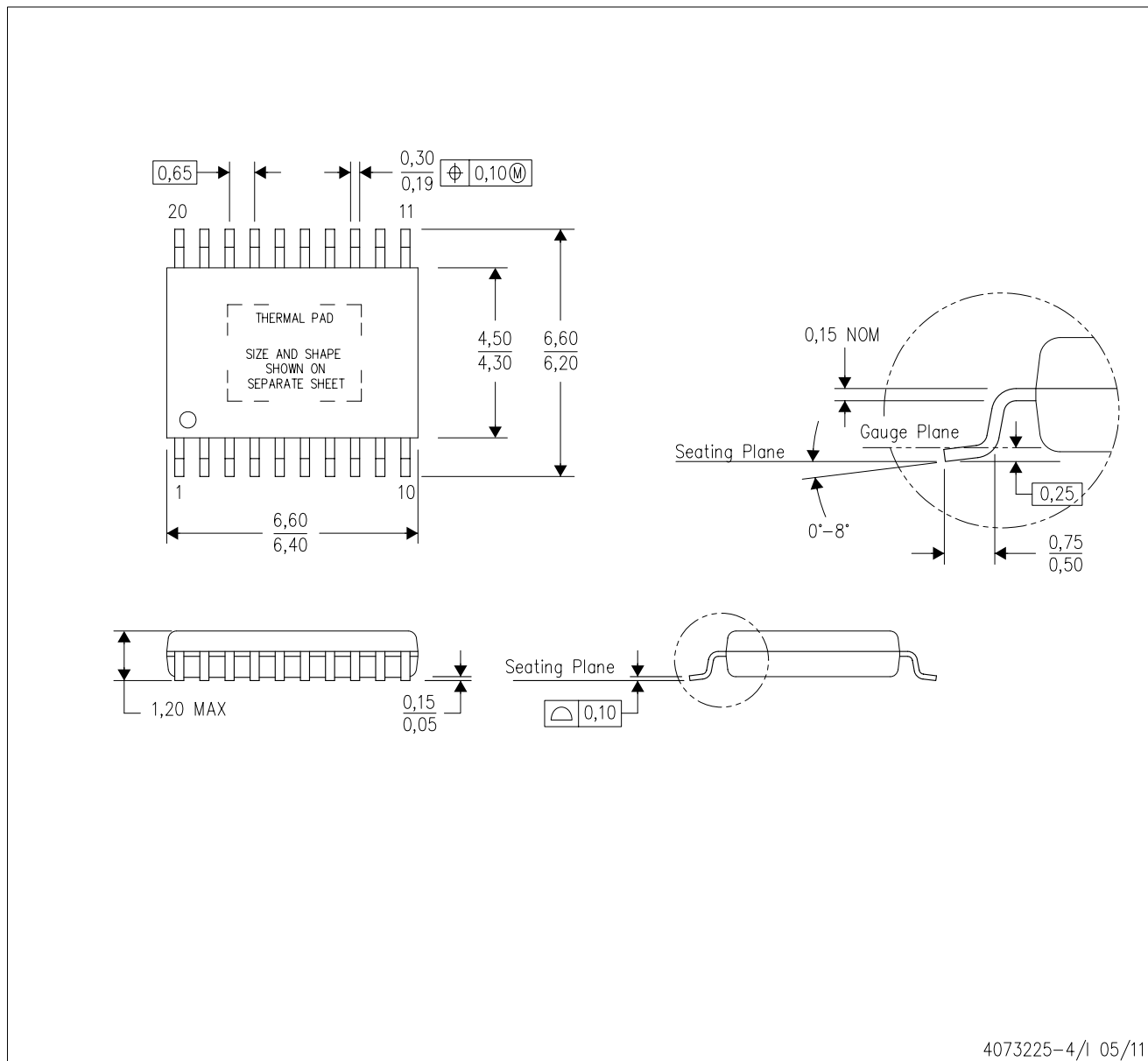
PowerPAD™ PLASTIC SMALL OUTLINE



4073225-4/1 05/11

- NOTES:
- All linear dimensions are in millimeters.
 - This drawing is subject to change without notice.
 - Body dimensions do not include mold flash or protrusions. Mold flash and protrusion shall not exceed 0.15 per side.
 - This package is designed to be soldered to a thermal pad on the board. Refer to Technical Brief, PowerPad Thermally Enhanced Package, Texas Instruments Literature No. SLMA002 for information regarding recommended board layout. This document is available at www.ti.com <<http://www.ti.com>>.
 - See the additional figure in the Product Data Sheet for details regarding the exposed thermal pad features and dimensions.
 - Falls within JEDEC MO-153

PowerPAD is a trademark of Texas Instruments.

THERMAL PAD MECHANICAL DATA

PWP (R-PDSO-G20) PowerPAD™ SMALL PLASTIC OUTLINE

THERMAL INFORMATION

This PowerPAD™ package incorporates an exposed thermal pad that is designed to be attached to a printed circuit board (PCB). The thermal pad must be soldered directly to the PCB. After soldering, the PCB can be used as a heatsink. In addition, through the use of thermal vias, the thermal pad can be attached directly to the appropriate copper plane shown in the electrical schematic for the device, or alternatively, can be attached to a special heatsink structure designed into the PCB. This design optimizes the heat transfer from the integrated circuit (IC).

For additional information on the PowerPAD package and how to take advantage of its heat dissipating abilities, refer to Technical Brief, PowerPAD Thermally Enhanced Package, Texas Instruments Literature No. SLMA002 and Application Brief, PowerPAD Made Easy, Texas Instruments Literature No. SLMA004. Both documents are available at www.ti.com.

The exposed thermal pad dimensions for this package are shown in the following illustration.

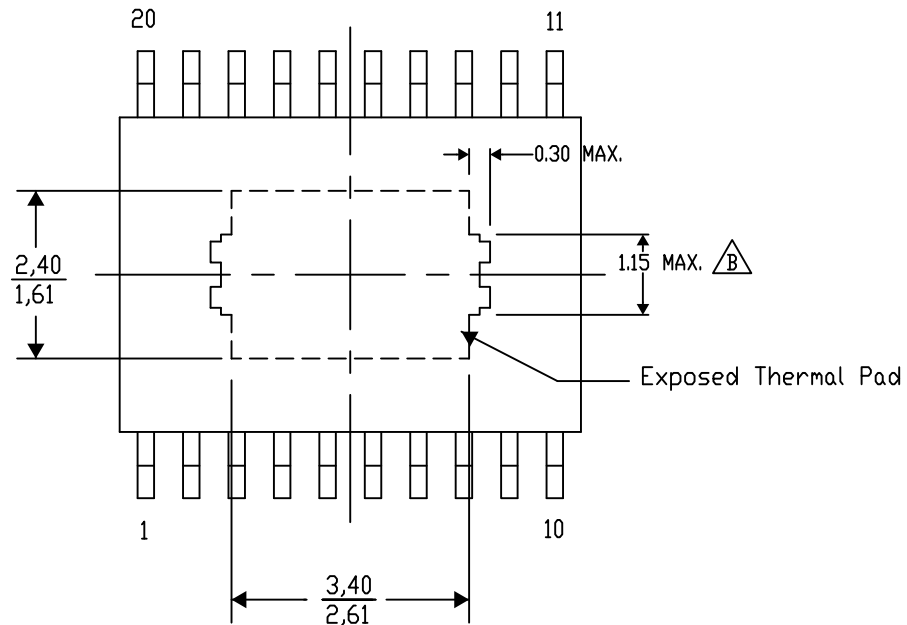

Top View

Exposed Thermal Pad Dimensions

4206332-15/AO 01/16

NOTE: A. All linear dimensions are in millimeters

$\triangle B$ Exposed tie strap features may not be present.

PowerPAD is a trademark of Texas Instruments

PWP (R-PDSO-G20)

PowerPAD™ PLASTIC SMALL OUTLINE

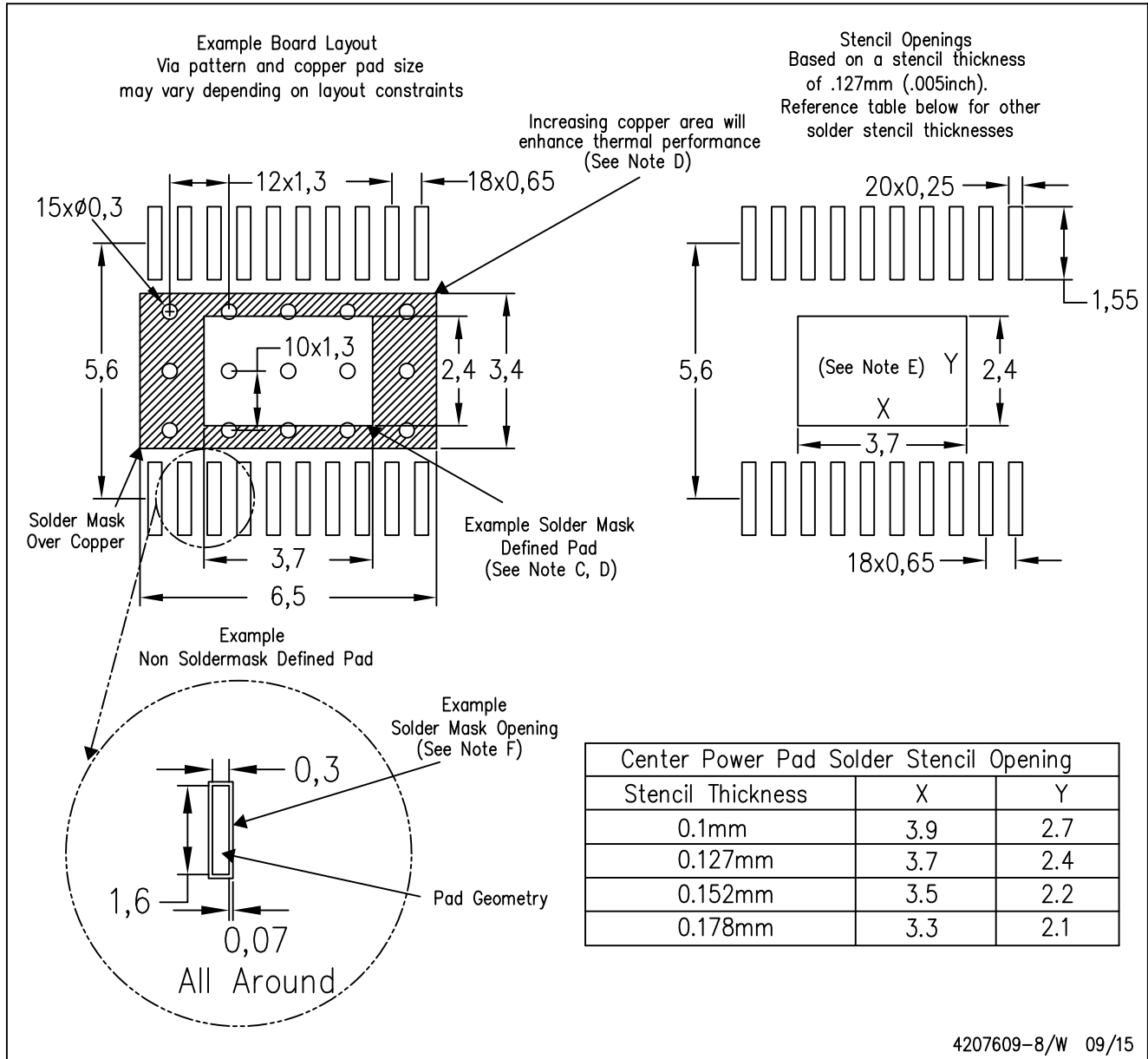

4207609-8/W 09/15

- NOTES:
- A. All linear dimensions are in millimeters.
 - B. This drawing is subject to change without notice.
 - C. Customers should place a note on the circuit board fabrication drawing not to alter the center solder mask defined pad.
 - D. This package is designed to be soldered to a thermal pad on the board. Refer to Technical Brief, PowerPad Thermally Enhanced Package, Texas Instruments Literature No. SLMA002, SLMA004, and also the Product Data Sheets for specific thermal information, via requirements, and recommended board layout. These documents are available at www.ti.com <<http://www.ti.com>>. Publication IPC-7351 is recommended for alternate designs.
 - E. Laser cutting apertures with trapezoidal walls and also rounding corners will offer better paste release. Customers should contact their board assembly site for stencil design recommendations. Example stencil design based on a 50% volumetric metal load solder paste. Refer to IPC-7525 for other stencil recommendations.
 - F. Customers should contact their board fabrication site for solder mask tolerances between and around signal pads.

IMPORTANT NOTICE AND DISCLAIMER

TI PROVIDES TECHNICAL AND RELIABILITY DATA (INCLUDING DATASHEETS), DESIGN RESOURCES (INCLUDING REFERENCE DESIGNS), APPLICATION OR OTHER DESIGN ADVICE, WEB TOOLS, SAFETY INFORMATION, AND OTHER RESOURCES "AS IS" AND WITH ALL FAULTS, AND DISCLAIMS ALL WARRANTIES, EXPRESS AND IMPLIED, INCLUDING WITHOUT LIMITATION ANY IMPLIED WARRANTIES OF MERCHANTABILITY, FITNESS FOR A PARTICULAR PURPOSE OR NON-INFRINGEMENT OF THIRD PARTY INTELLECTUAL PROPERTY RIGHTS.

These resources are intended for skilled developers designing with TI products. You are solely responsible for (1) selecting the appropriate TI products for your application, (2) designing, validating and testing your application, and (3) ensuring your application meets applicable standards, and any other safety, security, or other requirements. These resources are subject to change without notice. TI grants you permission to use these resources only for development of an application that uses the TI products described in the resource. Other reproduction and display of these resources is prohibited. No license is granted to any other TI intellectual property right or to any third party intellectual property right. TI disclaims responsibility for, and you will fully indemnify TI and its representatives against, any claims, damages, costs, losses, and liabilities arising out of your use of these resources.

TI's products are provided subject to TI's Terms of Sale (www.ti.com/legal/termsofsale.html) or other applicable terms available either on ti.com or provided in conjunction with such TI products. TI's provision of these resources does not expand or otherwise alter TI's applicable warranties or warranty disclaimers for TI products.

Mailing Address: Texas Instruments, Post Office Box 655303, Dallas, Texas 75265
Copyright © 2019, Texas Instruments Incorporated

Looking for pricing, stock, or lifecycle information?

Click below to explore more details on WIN SOURCE:

 [View TPS70202PWPR on WIN SOURCE](#)

 [Texas Instruments](#) Information

Optimize Your Supply Chain with WIN SOURCE Solutions

-  Global Sourcing Solution
-  Obsolete Management
-  Cost Control Management
-  Shortage Management
-  Alternative Solution
-  Excess Inventory Management