



# THE DATASHEET OF ISO1H802G



# ISOFACE™

ISO1H802G

Coreless Transformer Isolated  
Digital Output 8 Channel 0.625A  
High-Side Switch

**Power Management & Drives**



Never stop thinking.

---

**ISO1H802G****Revision History: 2009-09-16**

Version 2.4

Previous Version: V2.3

---

2.0	Final Datasheet
2.1	Final Datasheet
2.2	Page 16 creepage, clearance distance and $V_{ISO}$ adapted
2.3	Data for parallel channels and UL aproval added
2.4	Diagnostic output discontinued

---

**Edition 2009-09-16****Published by Infineon Technologies AG,  
Am Campeon 1-12,  
85579 Neubiberg, Germany****© Infineon Technologies AG 2009.  
All Rights Reserved.****Attention please!**

The information herein is given to describe certain components and shall not be considered as a guarantee of characteristics.

Terms of delivery and rights to technical change reserved.

We hereby disclaim any and all warranties, including but not limited to warranties of non-infringement, regarding circuits, descriptions and charts stated herein.

**Information**

For further information on technology, delivery terms and conditions and prices please contact your nearest Infineon Technologies Office ([www.infineon.com](http://www.infineon.com)).

**Warnings**

Due to technical requirements components may contain dangerous substances. For information on the types in question please contact your nearest Infineon Technologies Office.

Infineon Technologies Components may only be used in life-support devices or systems with the express written approval of Infineon Technologies, if a failure of such components can reasonably be expected to cause the failure of that life-support device or system, or to affect the safety or effectiveness of that device or system. Life support devices or systems are intended to be implanted in the human body, or to support and/or maintain and sustain and/or protect human life. If they fail, it is reasonable to assume that the health of the user or other persons may be endangered.

### Coreless Transformer Isolated Digital Output 8 Channel 0.625A High-Side Switch

#### Product Highlights

- Coreless transformer isolated data interface
- Galvanic isolation
- 8 High-side output switches 0.625A
- $\mu\text{C}$  compatible 8-bit serial peripheral
- UL508 compliant



#### Features

- Interface CMOS 5V operation compatible
- Serial Interface
- High common mode transient immunity
- Short circuit protection
- Maximum current internally limited
- Overload protection
- Overvoltage protection (including load dump)
- Undervoltage shutdown with autorestart and hysteresis
- Switching inductive loads
- Common output disable pin
- Thermal shutdown with restart
- Thermal independence of separate channels
- ESD protection
- Loss of  $\text{GND}_{\text{bb}}$  and loss of  $V_{\text{bb}}$  protection
- Very low standby current
- Reverse battery protection
- RoHS compliant

#### Typical Application

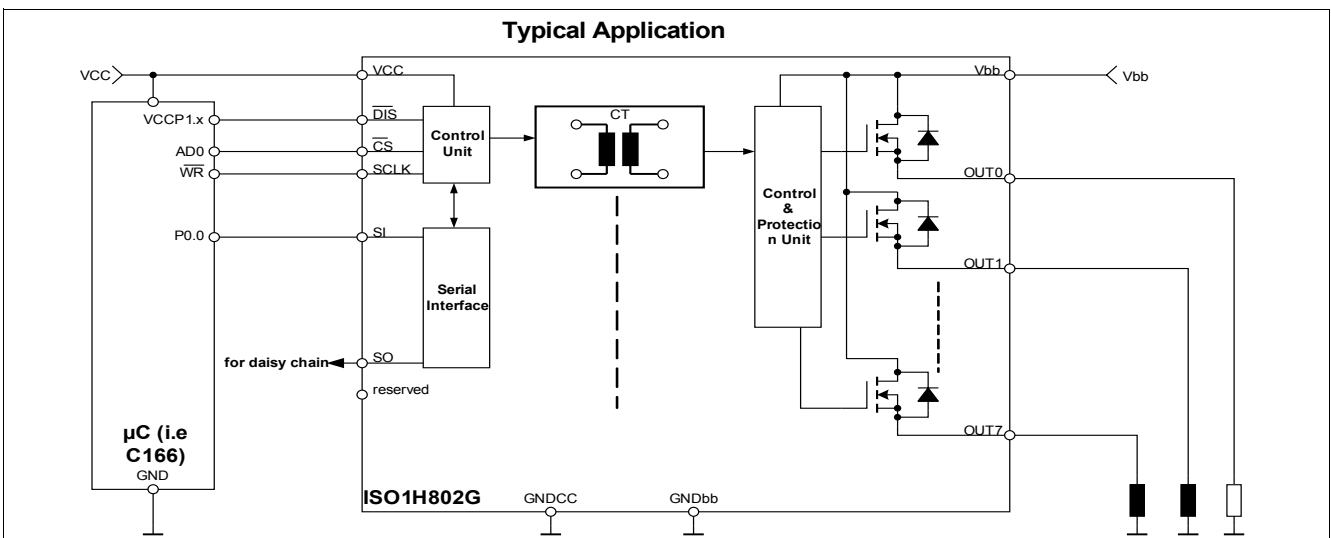
- Isolated switch for industrial applications (PLC)
- All types of resistive, inductive and capacitive loads
- $\mu\text{C}$  compatible power switch for 24V DC applications
- Driver for solenoid, relays and resistive loads

#### Description

The ISO1H802G is a galvanically isolated 8 bit data interface in PG-DSO-36 package that provides 8 fully protected high-side power switches that are able to handle currents up to 625 mA.

An serial  $\mu\text{C}$  compatible interface allows to connect the IC directly to a  $\mu\text{C}$  system. The input interface is designed to operate with 5V CMOS compatible levels.

The data transfer from input to output side is realized by the integrated Coreless Transformer Technology.

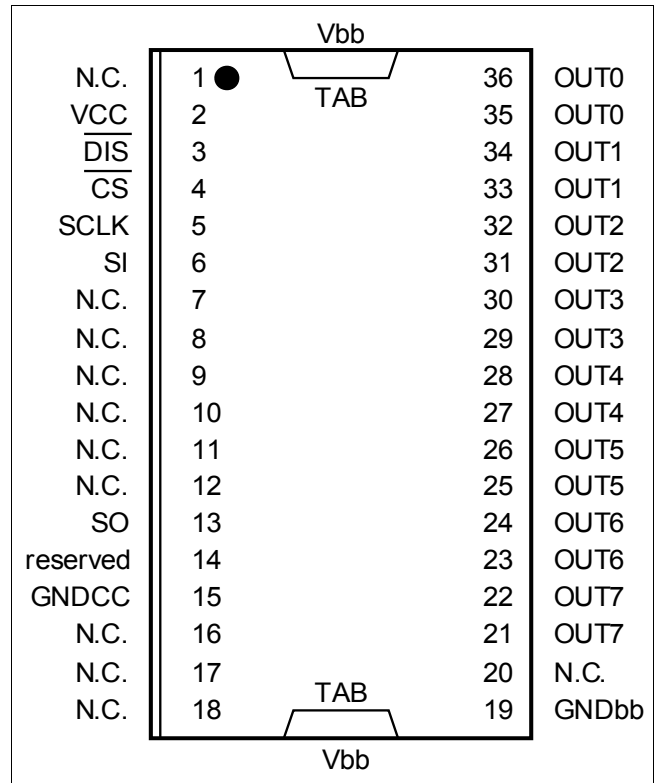


Type	On-state Resistance	Package
ISO1H802G	200m $\Omega$	PG-DSO-36

# 1 Pin Configuration and Functionality

## 1.1 Pin Configuration

Pin	Symbol	Function
1	N.C.	Not connected
2	VCC	Positive 5V logic supply
3	$\overline{\text{DIS}}$	Output disable
4	$\overline{\text{CS}}$	Chip select
5	SCLK	Serial Clock
6	SI	Serial Data input
7	N.C.	Not connected
8	N.C.	Not connected
9	N.C.	Not connected
10	N.C.	Not connected
11	N.C.	Not connected
12	N.C.	Not connected
13	SO	Serial Data Output
14	reserved	-
15	GNDCC	Input logic ground
16	N.C.	Not connected
17	N.C.	Not connected
18	N.C.	Not connected
19	GNDbb	Output driver ground
20	N.C	Not connected
21	OUT7	High-side output of channel 7
22	OUT7	High-side output of channel 7
23	OUT6	High-side output of channel 6
24	OUT6	High-side output of channel 6
25	OUT5	High-side output of channel 5
26	OUT5	High-side output of channel 5
27	OUT4	High-side output of channel 4
28	OUT4	High-side output of channel 4
29	OUT3	High-side output of channel 3
30	OUT3	High-side output of channel 3
31	OUT2	High-side output of channel 2
32	OUT2	High-side output of channel 2
33	OUT1	High-side output of channel 1
34	OUT1	High-side output of channel 1
35	OUT0	High-side output of channel 0
36	OUT0	High-side output of channel 0
TAB	Vbb	Positive driver power supply voltage



**Figure 1 Power SO-36 (430mil)**

## 1.2 Pin Functionality

### VCC (Positive 5V logic supply)

The VCC supplies the input interface that is galvanically isolated from the output driver stage. The input interface can be supplied with 5V.

### $\overline{\text{DIS}}$ (Output disable)

The high-side outputs OUT0...OUT7 can be immediately switched off by means of the low active pin  $\overline{\text{DIS}}$  that is an asynchronous signal. The input registers are also reset by the  $\overline{\text{DIS}}$  signal. The output remains switched off after low-high transient of  $\overline{\text{DIS}}$ , till new data is written into the input interface.

Current Sink to GNDCC

### $\overline{\text{CS}}$ (Chip select)

The system microcontroller selects the ISO1H802G by means of the low active pin  $\overline{\text{CS}}$  to activate the interface. Current Source to VCC

### SCLK (Serial shift clock)

SCLK (serial clock) is used to synchronize the data transfer between the master and the ISO1H802G. Data present at the SI pin are latched on the rising edge of the serial clock input, while data at the SO pin is updated after the falling edge of SCLK in serial mode. Current Source to VCC

### SI (Serial data input)

This pin is used to transfer data into the device. Data is latched on the rising edge of the serial clock. Current Sink to GNDCC

### SO (Serial data output)

This pin is used when the serial interface is activated. SO can be connected to a serial input of a further IC to build a daisy-chain configuration. It is only activated if  $\overline{\text{CS}}$  is in low state, otherwise this output is in high impedance state.

### GNDCC (Ground for VCC domain)

This pin acts as the ground reference for the input interface that is supplied by VCC.

### GNDbb (Output driver ground domain)

This pin acts as the ground reference for the output driver that is supplied by Vbb.

### OUT0 ... OUT7 (High side output channel 0 ... 7)

The output high side channels are internally connected

to Vbb and controlled by the corresponding data input.

### TAB (Vbb, Positive supply for output driver)

The heatslug is connected to the positive supply port of the output interface.

2 Blockdiagram

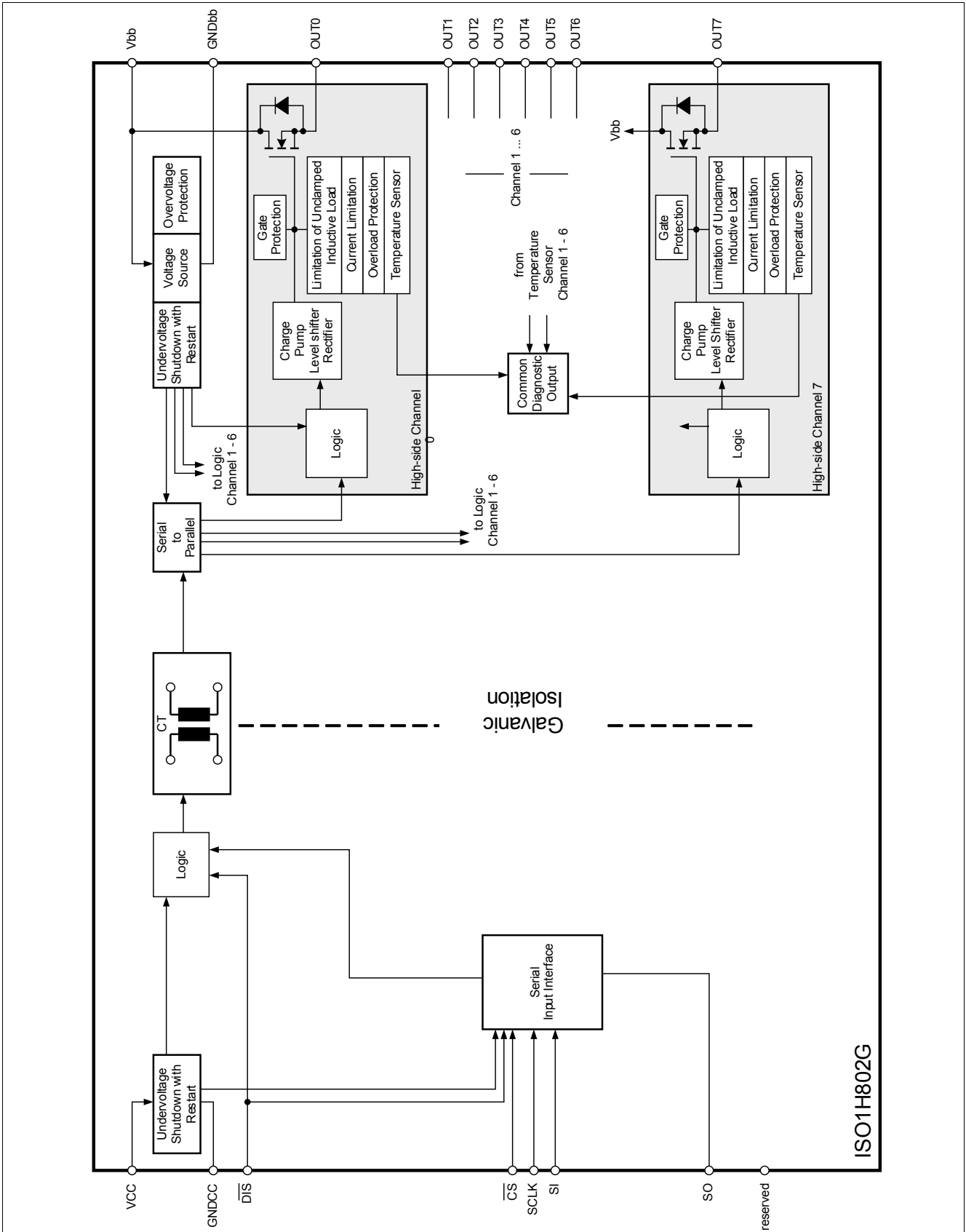


Figure 2 Blockdiagram

### 3 Functional Description

#### 3.1 Introduction

The ISOface ISO1H802G includes 8 high-side power switches that are controlled by means of the integrated  $\mu$ C compatible SPI interface. The outputs OUT0...OUT7 are controlled by the data of the serial input SI. The IC can replace 8 optocouplers and the 8 high-side switches in conventional I/O-Applications as a galvanic isolation is implemented by means of the integrated coreless transformer technology. The  $\mu$ C compatible interfaces allow a direct connection to the ports of a microcontroller without the need for other components. Each of the 8 high-side power switches is protected against short to V<sub>bb</sub>, overload, overtemperature and against overvoltage by an active zener clamp.

The diagnostic logic on the power chip recognizes the overtemperature information of each power transistor.

#### 3.2 Power Supply

The IC contains 2 galvanic isolated voltage domains that are independent from each other. The input interface is supplied at V<sub>CC</sub> and the output stage is supplied at V<sub>bb</sub>. The different voltage domains can be switched on at different time. The output stage is only enabled once the input stage enters a stable state.

#### 3.3 Output Stage

Each channel contains a high-side vertical power FET that is protected by embedded protection functions.

The continuous current for each channel is 625mA (all channels ON).

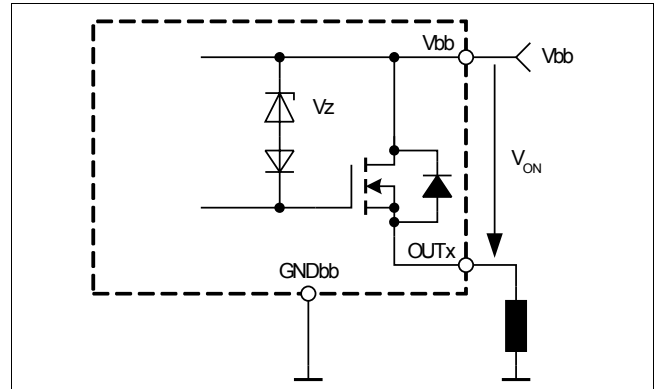
##### 3.3.1 Output Stage Control

Each output is independently controlled by an output latch and a common reset line via the pin DIS that disables all eight outputs and reset the latches. Serial data input (SI) is read on the rising edge of the serial clock SCLK. A logic high input data bit turns the respective output channel ON, a logic low data bit turns it OFF. CS must be low whilst shifting all the serial data into the device. A low-to-high transition of CS transfers the serial data input bits to the output buffer.

##### 3.3.2 Power Transistor Overvoltage Protection

Each of the eight output stages has its own zener clamp that causes a voltage limitation at the power transistor

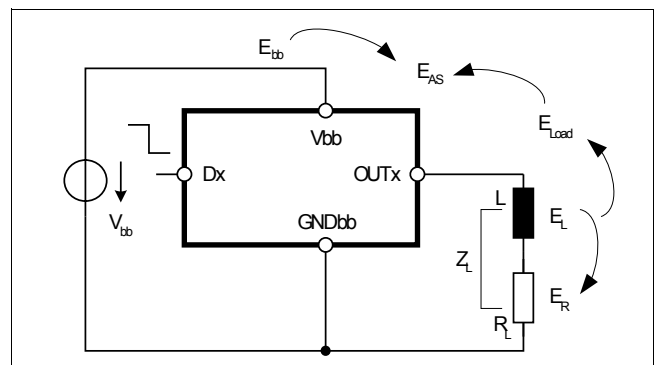
when solenoid loads are switched off. V<sub>ON</sub> is then clamped to 47V (min.).



**Figure 3 Inductive and overvoltage output clamp (each channel)**

Energy is stored in the load inductance during an inductive load switch-off.

$$E_L = 1/2 \times L \times I_L^2$$



**Figure 4 Inductive load switch-off energy dissipation (each channel)**

While demagnetizing the load inductance, the energy dissipation in the DMOS is

$$E_{AS} = E_{bb} + E_L - E_R = V_{ON(CL)} \times i_L(t)dt$$

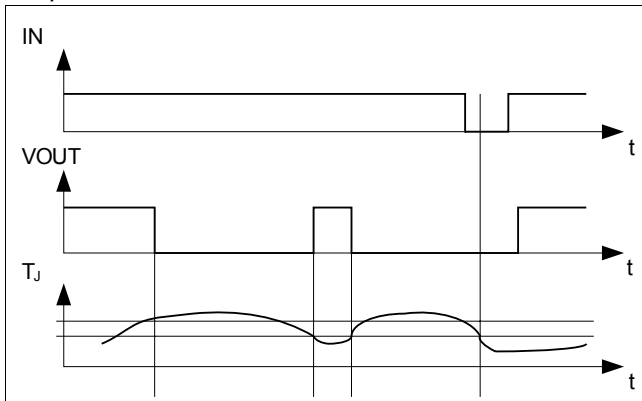
with an approximate solution for  $R_L > 0\Omega$ :

$$E_{AS} = \frac{I_L \times L}{2 \times R_L} \times (V_{bb} + |V_{ON(CL)}|) \times \ln\left(1 + \frac{I_L \times R_L}{|V_{ON(CL)}|}\right)$$

##### 3.3.3 Power Transistor Overcurrent Protection

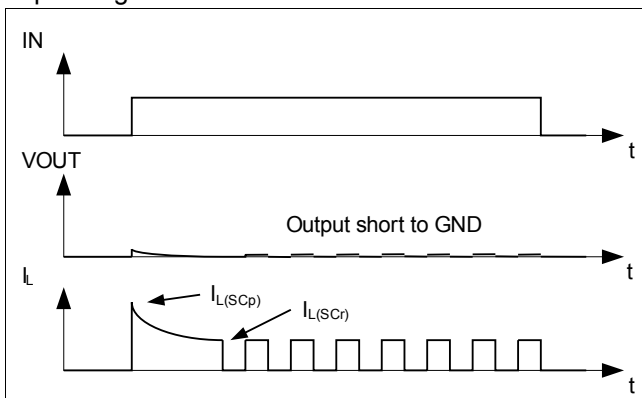
The outputs are provided with a current limitation that enters a repetitive switched mode after an initial peak current has been exceeded. The initial peak short circuit current limit is set to  $I_{L(SCP)}$  at  $T_j = 125^\circ\text{C}$ . During the repetitive mode short circuit current limit is set to  $I_{L(SCR)}$ . If this operation leads to an overtemperature

condition, a second protection level ( $T_j > 135^\circ\text{C}$ ) will change the output into a low duty cycle PWM (selective thermal shutdown with restart) to prevent critical chip temperatures.

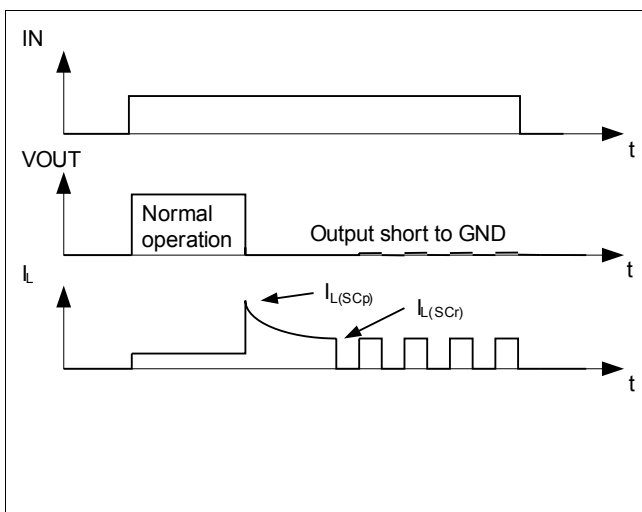


**Figure 5 Overtemperature detection**

The following figures show the timing for a turn on into short circuit and a short circuit in on-state. Heating up of the chip may require several milliseconds, depending on external conditions.



**Figure 6 Turn on into short circuit, shut down by overtemperature, restart by cooling**



**Figure 7 Short circuit in on-state, shut down**

**down by overtemperature, restart by cooling**

### 3.4 Reserved

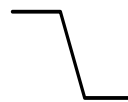
### 3.5 Serial Interface

The ISO1H802G contains a serial interface that can be directly controlled by the microcontroller output ports.

#### 3.5.1 SPI Signal Description

**CS** - Chip select. The system microcontroller selects the ISO1H802G by means of the CS pin. Whenever the pin is in a logic low state, data can be transferred from the  $\mu\text{C}$ .

CS High to low transition:



- Serial input data can be clocked in from then on
- SO changes from high impedance state to logic high or low state corresponding to the SO bit-state

CS Low to high transition:



- Transfer of SI bits from shift register into output buffers, if number of clock signals was an integer multiple of 8
- SO changes from the SO bit-state to high impedance state

To avoid any false clocking the serial input pin SCLK should be logic high state during high-to-low transition of CS. When CS is in a logic high state, any signals at the SCLK and SI pins are ignored and SO is forced into a high impedance state. The integrated modulo counter that counts the number of clocks avoids the take over of invalid commands caused by a spike on the clock line or wrong number of clock cycles. A command is only taken over if after the low-to-high transition of the CS signal the number of counted clock cycles is an integer multiple of 8.

**SCLK** - Serial clock. The system clock pin clocks the internal shift register of the ISO1H802G. The serial input (SI) accepts data into the input shift register on the rising edge of SCLK while the serial output (SO) shifts the output information out of the shift register on the falling edge of the serial clock. It is essential that the SCLK pin is in a logic high state whenever chip select

$\overline{CS}$  makes any transition. The number of clock pulses will be counted during a chip select cycle. The received data will only be accepted, if exactly an integer multiple of 8 clock pulses were counted during  $\overline{CS}$  is active.

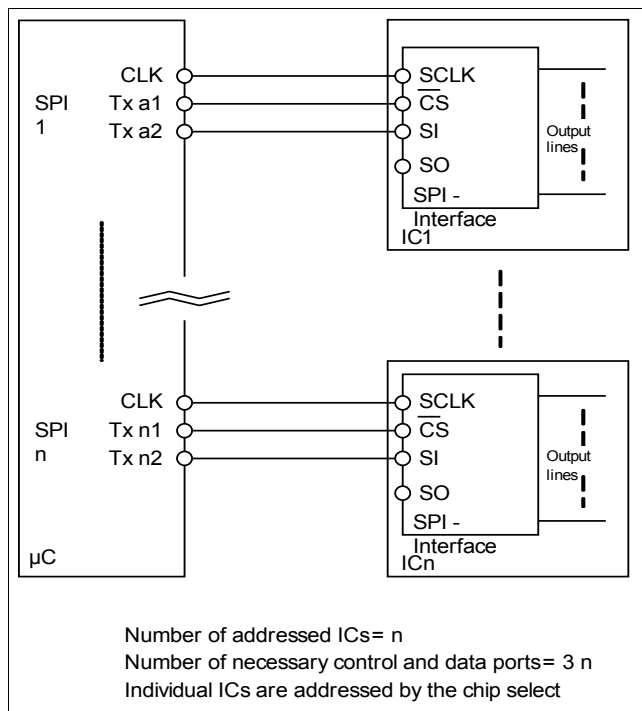
**SI** - Serial input. Serial data bits are shifted in at this pin, the most significant bit first. SI information is read in on the rising edge of the SCLK. Input data is latched in the shift register and then transferred to the control buffer of the output stages.

**SO** - Serial output. SO is in a high impedance state until the  $\overline{CS}$  pin goes to a logic low state. The data of the internal shift register are shifted out serially at this pin. The most significant bit will appear at first. The further bits will appear following the falling edge of SCLK.

### 3.5.2 SPI Bus Concepts

#### 3.5.2.1 Independent Individual Control

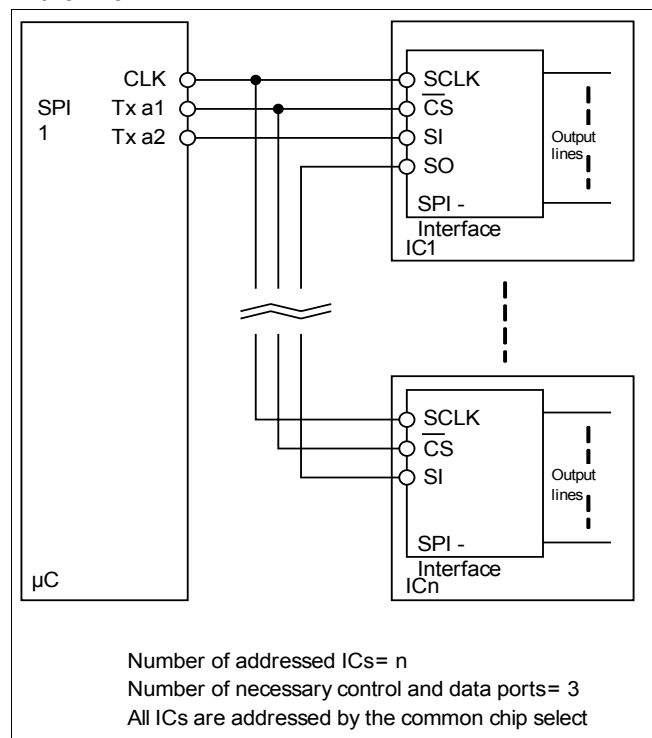
Each IC with a SPI is controlled individually and independently by an SPI master, as in a directional point-to-point communication. The port requirements for this topology are the greatest, because for each controlled IC an individual SPI at the  $\mu C$  is needed (SCLK,  $\overline{CS}$ , SI). All ICs can be addressed simultaneously with the full SPI bandwidth.



**Figure 8 Individual independent control of each IC with SPI**

#### 3.5.2.2 Daisy-chain Configuration

The connection of different ICs and a  $\mu C$  as shown in Fig. 11 is called a daisy-chain. For this type of bus-topology only one SPI interface of the  $\mu C$  for two or more ICs is needed. All ICs share the same clock and chip select port of the SPI master. That is all ICs are active and addressed simultaneously. The data out of the  $\mu C$  is connected to the SI of the first IC in the line. Each SO of an IC is connected to the SI of the next IC in the line.

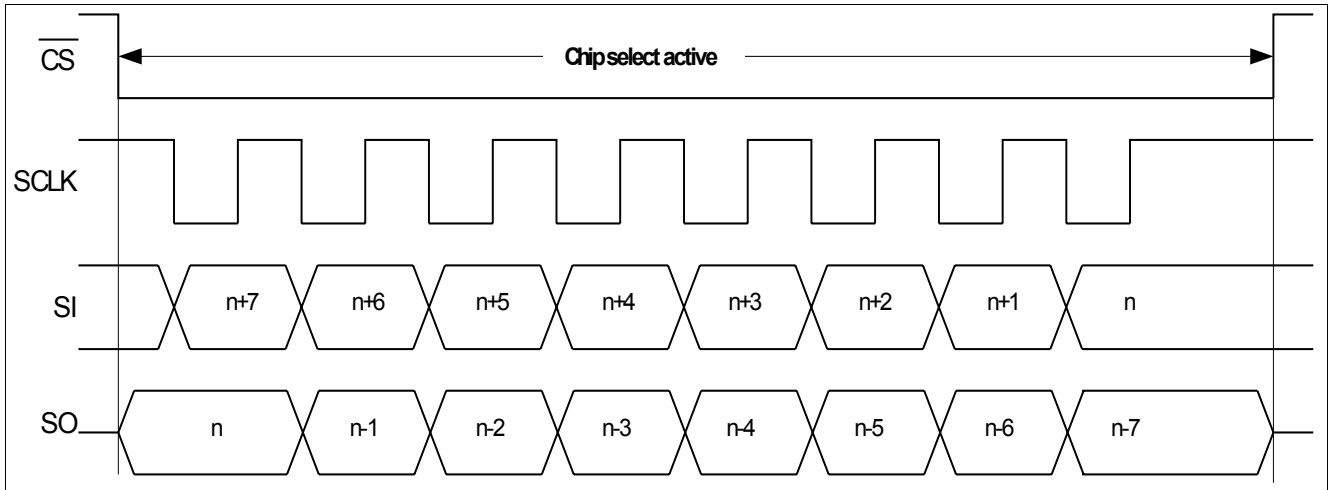
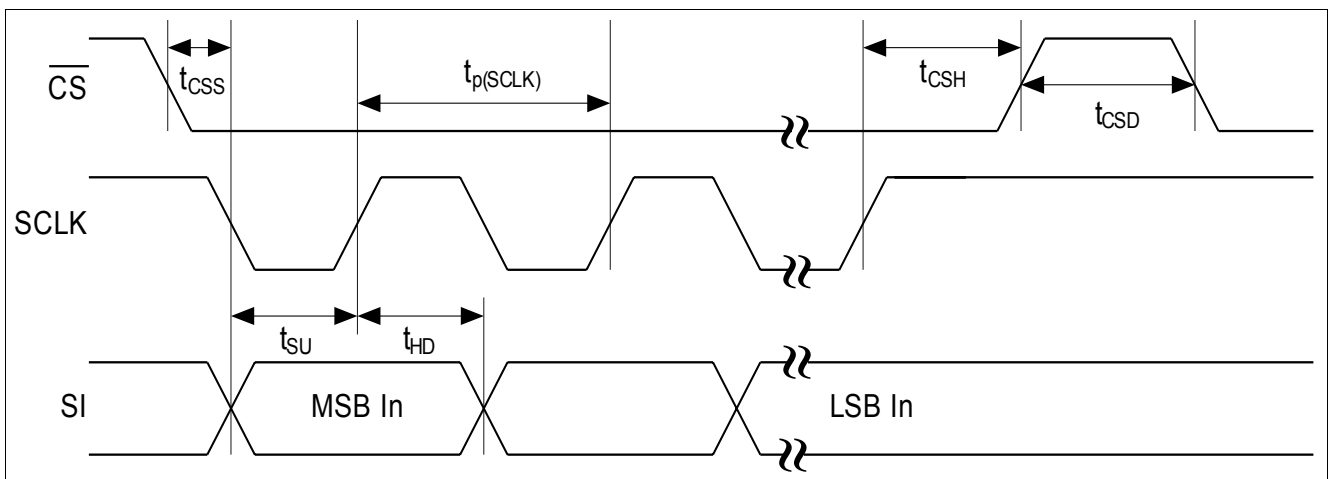
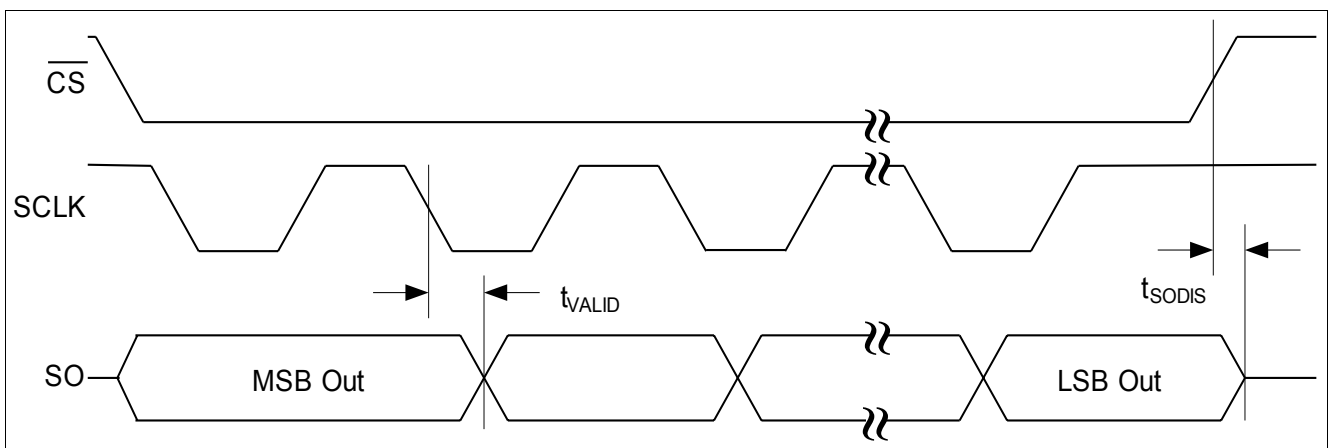


**Figure 9 SPI bus all ICs in a "daisy chain" configuration**

The  $\mu C$  feeds to data bits into the SI of IC1 (first IC in the chain). The bits coming from the SO of IC1 are directly shifted into the SI of the next IC. As long as the chip select is inactive (logic high) all the IC SPIs ignore the clock (SCLK) and input signals (SI) and all outputs (SO) are in tristate. As long as the chip select is active the SPI register works as a simple shift register. With each clock signal one input is shifted into the SPI register (SI), each bit in the shift register moves one position further within the register, and the last bit in the SPI shift register is shifted out of SO. This continuous as long as the chip select is active (logic low) and clock signals are applied. The data is then only taken over to the output buffers of each IC when the CS signal changes to high from low and recognized as valid data by the internal modulo counter.

### **3.6 Transmission Failure Detection**

There is a failure detection unit integrated to ensure also a stable functionality during the integrated coreless transformer transmission. This unit decides whether the transmitted data is valid or not. If four times serial data coming from the internal registers is not accepted the output stages are switched off until the next valid data is received.

**3.7 Serial Interface Timing**

**Figure 10 Serial interface**

**Figure 11 Serial input timing diagram**

**Figure 12 Serial output timing diagram**

## 4 Electrical Characteristics

Note: All voltages at pins 2 to 14 are measured with respect to ground GND<sub>CC</sub> (pin 15). All voltages at pin 20 to pin 36 and TAB are measured with respect to ground GND<sub>bb</sub> (pin 19). The voltage levels are valid if other ratings are not violated. The two voltage domains  $V_{CC}$ , GND<sub>CC</sub> and  $V_{bb}$ , GND<sub>bb</sub> are internally galvanic isolated.

### 4.1 Absolute Maximum Ratings

Note: Absolute maximum ratings are defined as ratings, which when being exceeded may lead to destruction of the integrated circuit. For the same reason make sure, that any capacitor that will be connected to pin 2 (VCC) and TAB (Vbb) is discharged before assembling the application circuit. Supply voltages higher than  $V_{bb(AZ)}$  require an external current limit for the GND<sub>bb</sub> pin, e.g. with a 15Ω resistor in GND<sub>bb</sub> connection. Operating at absolute maximum ratings can lead to a reduced lifetime.

Parameter at $T_j = -40 \dots 135^\circ\text{C}$ , unless otherwise specified	Symbol	Limit Values		Unit
		min.	max.	
Supply voltage input interface (VCC)	$V_{CC}$	-0.5	6.5	V
Supply voltage output interface (Vbb)	$V_{bb}$	-1 <sup>1)</sup>	45	
Continuous voltage at pin SI	$V_{Dx}$	-0.5	6.5	
Continuous voltage at pin CS	$V_{CS}$	-0.5	6.5	
Continuous voltage at pin SCLK	$V_{WR}$	-0.5	6.5	
Continuous voltage at pin DIS	$V_{DIS}$	-0.5	6.5	
Continuous voltage at pin SO	$V_{Dx}$	-0.5	6.5	
Continuous voltage at reserved pin	$V_{Reserved}$	-0.5	6.5	
Load current (short-circuit current)	$I_L$	---	self limited	
Reverse current through GND <sub>bb</sub> <sup>1)</sup>	$I_{GNDbb}$	-1.6	---	
Operating Temperature	$T_j$	-25	internal limited	°C
Storage Temperature	$T_{stg}$	-50	150	
Power Dissipation <sup>2)</sup>	$P_{tot}$	---	3.3	W
Inductive load switch-off energy dissipation <sup>3)</sup> single pulse, $T_j = 125^\circ\text{C}$ , $I_L = 0.625\text{A}$ one channel active all channel simultaneously active (each channel)	$E_{AS}$	---	10 1	J
Load dump protection <sup>3)</sup> $V_{loadDump}^{4)} = V_A + V_S$ $V_{IN} = \text{low or high}$ $t_d = 400\text{ms}$ , $R_I = 2\text{W}$ , $R_L = 27\text{W}$ , $V_A = 13.5\text{V}$ $t_d = 350\text{ms}$ , $R_I = 2\text{W}$ , $R_L = 57\text{W}$ , $V_A = 27\text{V}$	$V_{Loaddump}$	---	90 117	
Electrostatic discharge voltage (Human Body Model) according to JESD22-A114-B	$V_{ESD}$		2	kV
Electrostatic discharge voltage (Charge Device Model) according to ESD STM5.3.1 - 1999	$V_{ESD}$		1	kV
Continuous reverse drain current <sup>1)3)</sup> , each channel	$I_S$	---	4	A

1) defined by  $P_{tot}$

2) Device on 50mm\*50mm\*1.5mm epoxy PCB FR4 with 6cm<sup>2</sup> (one layer, 70μm thick) copper area for drain connection. PCB is vertical without blown air.

3) not subject to production test, specified by design

4)  $V_{Loaddump}$  is setup without the DUT connected to the generator per ISO7637-1 and DIN40839

## 4.2 Thermal Characteristics

Parameter at $T_j = -25 \dots 125^\circ\text{C}$ , $V_{bb}=15\dots30\text{V}$ , $V_{CC}=4.5\dots5.5\text{V}$ , unless otherwise specified	Symbol	Limit Values			Unit	Test Condition
		min.	typ.	max.		
Thermal resistance junction - case	$R_{thJC}$	---	---	1.5	K/W	
Thermal resistance @ min. footprint	$R_{th(JA)}$	---	---	50		
Thermal resistance @ $6\text{cm}^2$ cooling area <sup>1)</sup>	$R_{th(JA)}$	---	---	38		

1) Device on  $50\text{mm} \times 50\text{mm} \times 1.5\text{mm}$  epoxy PCB FR4 with  $6\text{cm}^2$  (one layer,  $70\mu\text{m}$  thick) copper area for drain connection. PCB is vertical without blown air.

## 4.3 Load Switching Capabilities and Characteristics

Parameter at $T_j = -25 \dots 125^\circ\text{C}$ , $V_{bb}=15\dots30\text{V}$ , $V_{CC}=4.5\dots5.5\text{V}$ , unless otherwise specified	Symbol	Limit Values			Unit	Test Condition
		min.	typ.	max.		
On-state resistance, $I_L = 0.5\text{A}$ , each channel $T_j = 25^\circ\text{C}$ $T_j = 125^\circ\text{C}$ two parallel channels, $T_j = 25^\circ\text{C}$ : <sup>1)</sup> four parallel channels, $T_j = 25^\circ\text{C}$ : <sup>1)</sup>	$R_{ON}$	---	150 270 75 38	200 320 100 50	mΩ	
Nominal load current Device on PCB $38\text{K/W}$ , $T_a = 85^\circ\text{C}$ , $T_j < 125^\circ\text{C}$ one channel: <sup>1)</sup> two parallel channels: <sup>1)</sup> four parallel channels: <sup>1)</sup>	$I_{L(NOM)}$		0.7 1.1 2.2			A
Turn-on time to 90% $V_{OUT}$ <sup>2)</sup> $R_L = 47\Omega$ , $V_{Dx} = 0$ to $5\text{V}$	$t_{on}$	---	64	120	μs	
Turn-off time to 10% $V_{OUT}$ <sup>1)</sup> $R_L = 47\Omega$ , $V_{Dx} = 5$ to $0\text{V}$	$t_{off}$	---	89	170		
Slew rate on 10 to 30% $V_{OUT}$ $R_L = 47\Omega$ , $V_{bb} = 15\text{V}$	$dV/dt_{on}$	---	1	2	V/μs	
Slew rate off 70 to 40% $V_{OUT}$ $R_L = 47\Omega$ , $V_{bb} = 15\text{V}$	$-dV/dt_{off}$	---	1	2		

1) not subject to production test, specified by design

2) The turn-on and turn-off time includes the switching time of the high-side switch and the transmission time via the coreless transformer in normal operating mode. During a failure on the coreless transformer transmission turn-on or turn-off time can increase by up to  $50\mu\text{s}$ .

## 4.4 Operating Parameters

Parameter at $T_j = -25 \dots 125^\circ\text{C}$ , $V_{bb}=15\dots30\text{V}$ , $V_{CC}=4.5\dots5.5\text{V}$ , unless otherwise specified	Symbol	Limit Values			Unit	Test Condition	
		min.	typ.	max.			
Common mode transient immunity <sup>1)</sup>	$dV_{ISO}/dt$	-25	-	25	kV/μs	$DV_{ISO} = 500\text{V}$	
Magnetic field immunity <sup>1)</sup>	$H_{IM}$	100			A/m	IEC61000-4-8	
Voltage domain $V_{bb}$ (Output interface)	Undervoltage shutdown	$V_{bb(under)}$	7	---	10.5	V	
	Undervoltage restart	$V_{bb(u_rst)}$	---	---	11		

**Electrical Characteristics**

	Undervoltage hysteresis	$\Delta V_{bb(\text{under})}$	---	0.5	---		
	Undervoltage current	$I_{bb(\text{uvlo})}$	---	1	2.5	mA	$V_{bb} < 7V$
	Operating current	$I_{GNDL}$	---	10	14	mA	All Channels ON - no load
	Leakage output current (included in $I_{bb(\text{off})}$ ) $V_{Dx} = \text{low}$ , each channel	$I_{L(\text{off})}$	---	5	30	$\mu\text{A}$	
Voltage domain $V_{CC}$ (Input interface)	Operating voltage	$V_{CC}$	4.5	---	5.5	V	
	Undervoltage shutdown	$V_{CC(\text{under})}$	2.5	---	2.9		
	Undervoltage restart	$V_{CC(\text{u_rst})}$	---	---	3		
	Undervoltage hysteresis	$\Delta V_{CC(\text{under})}$	---	0.1	---		
	Undervoltage current	$I_{CC(\text{uvlo})}$	---	1	2	mA	$V_{cc} < 2.5V$
	Operating current	$I_{CC(\text{on})}$	---	4.5	6	mA	

1) not subject to production test

#### 4.5 Output Protection Functions

Parameter <sup>1)</sup> at $T_j = -25 \dots 125^\circ\text{C}$ , $V_{bb} = 15 \dots 30V$ , $V_{CC} = 4.5 \dots 5.5V$ , unless otherwise specified	Symbol	Limit Values			Unit	Test Condition
		min.	typ.	max.		
Initial peak short circuit current limit, each channel $V_{bb} = 30V$ , $t_m = 700\mu\text{s}$ $T_j = -25^\circ\text{C}$ $T_j = 25^\circ\text{C}$ $T_j = 125^\circ\text{C}$  two parallel channels: <sup>3)</sup> four parallel channels: <sup>3)</sup>	$I_{L(\text{SCP})}$	---	---	1.9	A	
		---	1.4	---		
		0.7	---	---		
		twice the current of one channel four times the current of one channel				
Repetitive short circuit current limit <sup>3)</sup> $T_j = T_{jt}$ (see timing diagrams)  each channel: two parallel channels: <sup>3)</sup> four parallel channels: <sup>3)</sup>	$I_{L(\text{SCR})}$	---	1.1	---		
			1.1			
			1.1			
Output clamp (inductive load switch off) at $V_{OUT} = V_{bb} - V_{ON(\text{CL})}$	$V_{ON(\text{CL})}$	47	53	60	V	
Overshoot protection	$V_{bb(\text{AZ})}$	47	---	---		
Thermal overload trip temperature <sup>2) 3)</sup>	$T_{jt}$	135	---	---	$^\circ\text{C}$	
Thermal hysteresis <sup>3)</sup>	$\Delta T_{jt}$	---	10	---	K	

1) Integrated protection functions are designed to prevent IC destruction under fault conditions described in the data sheet. Fault conditions are considered as "outside" normal operating range. Protection functions are not designed for continuous repetitive operation.

2) Higher operating temperature at normal function for each channel available

3) not subject to production test, specified by design

#### 4.6 Reserved

**4.7 Input Interface**

Parameter at $T_j = -25 \dots 125^\circ\text{C}$ , $V_{bb} = 15 \dots 30\text{V}$ , $V_{CC} = 4.5 \dots 5.5\text{V}$ , unless otherwise specified	Symbol	Limit Values			Unit	Test Condition
		min.	typ.	max.		
Input low state voltage (SI, $\overline{\text{DIS}}$ , $\overline{\text{CS}}$ , SCLK)	$V_{IL}$	-0.3	---	$0.3 \times V_{CC}$	V	
Input high state voltage (SI, DIS, CS, SCLK)	$V_{IH}$	$0.7 \times V_{CC}$	---	$V_{CC} + 0.3$	V	
Input voltage hysteresis (SI, $\overline{\text{DIS}}$ , $\overline{\text{CS}}$ , SCLK)	$V_{IHys}$		100		mV	
Output low state voltage (SO)	$V_{OL}$	-0.3	---	$0.25 \times V_{CC}$	V	$C_L < 50\text{pF}$ , $R_L > 10\text{k}\Omega$
Output high state voltage (SO)	$V_{OH}$	$0.75 \times V_{CC}$	---	$V_{CC} + 0.3$	V	
Input pull down current (SI, DIS)	$I_{Idown}$		100		$\mu\text{A}$	
Input pull up current ( $\overline{\text{CS}}$ , SCLK)	$-I_{Iup}$		100		$\mu\text{A}$	
Output disable time (transition $\overline{\text{DIS}}$ to logic low) <sup>1)2)</sup> Normal operation Turn-off time to 10% $V_{OUT}$ $R_L = 47\Omega$	$t_{DIS}$	---	85	170	$\mu\text{s}$	
Output disable time (transition $\overline{\text{DIS}}$ to logic low) <sup>1)2)3)</sup> Disturbed operation Turn-off time to 10% $V_{OUT}$ $R_L = 47\Omega$	$t_{DIS}$	---	---	230	$\mu\text{s}$	

- 1) The time includes the turn-on/off time of the high-side switch and the transmission time via the coreless transformer.
- 2) If Pin  $\overline{\text{DIS}}$  is set to low the outputs are set to low; after  $\overline{\text{DIS}}$  set to high a new write cycle is necessary to set the output again.
- 3) The parameter is not subject to production test - verified by design/characterization

## 4.8 SPI Timing

Parameter at $T_j = -25 \dots 125^\circ\text{C}$ , $V_{bb} = 15 \dots 30\text{V}$ , $V_{CC} = 4.5 \dots 5.5\text{V}$ , unless otherwise specified	Symbol	Limit Values			Unit	Test Condition
		min.	typ.	max.		
Serial clock frequency	$f_{\text{SCLK}}$	DC	---	20	MHz	
Serial clock period (1/fclk)	$t_{p(\text{SLCK})}$	50	---	---	ns	
CS Setup time (falling edge of $\overline{\text{CS}}$ to falling edge of SCLK)	$t_{\text{CSS}}$	5	---	---		
CS Hold time (rising edge of SCLK to rising edge of $\overline{\text{CS}}$ )	$t_{\text{CSH}}$	10	---	---		
CS Disable time (CS high time between two accesses)	$t_{\text{CSD}}$	10	---	---		
Data setup time (required time SI to rising edge of SCLK)	$t_{\text{SU}}$	6	---	---		
Data hold time (falling edge of SCLK to SI)	$t_{\text{HD}}$	6	---	---		
SO Output valid time CL = 50pF	$t_{\text{VALID}}$	---	---	20		
SO Output disable time	$t_{\text{SODIS}}$			20		

## 4.9 Reverse Voltage

Parameter at $T_j = -25 \dots 125^\circ\text{C}$ , $V_{bb} = 15 \dots 30\text{V}$ , $V_{CC} = 4.5 \dots 5.5\text{V}$ , unless otherwise specified	Symbol	Limit Values			Unit	Test Condition
		min.	typ.	max.		
Reverse voltage <sup>1)2)</sup> $R_{\text{GND}} = 0 \Omega$ $R_{\text{GND}} = 150 \Omega$	$-V_{bb}$	---	---	1 45	V	
Diode forward on voltage IF = 1.25A, $V_{Dx} = \text{low}$ , each channel	$-V_{\text{ON}}$	---	---	1.2		

1) defined by  $P_{\text{tot}}$

2) not subject to production test, specified by design

#### 4.10 Isolation and Safety-Related Specification

Parameter	Value	Unit	Conditions
Rated dielectric isolation voltage $V_{ISO}$	500	$V_{AC}$	1 - minute duration <sup>1)</sup>
Short term temporary overvoltage	1250	V	5s acc. DIN EN60664-1 <sup>1)</sup>
Minimum external air gap (clearance)	2.6	mm	shortest distance through air.
Minimum external tracking (creepage)	2.6	mm	shortest distance path along body.
Minimum Internal Gap	0.01	mm	Insulation distance through insulation

1) not subject to production test, verified by characterization; Production Test with 1100V, 100ms duration

#### Approvals:

UL508, CSA C22.2 NO.14

Certificate Number: 20090514-E329661

#### 4.11 Reliability

For Qualification Report please contact your local Infineon Technologies office!

## 5 Package Outlines

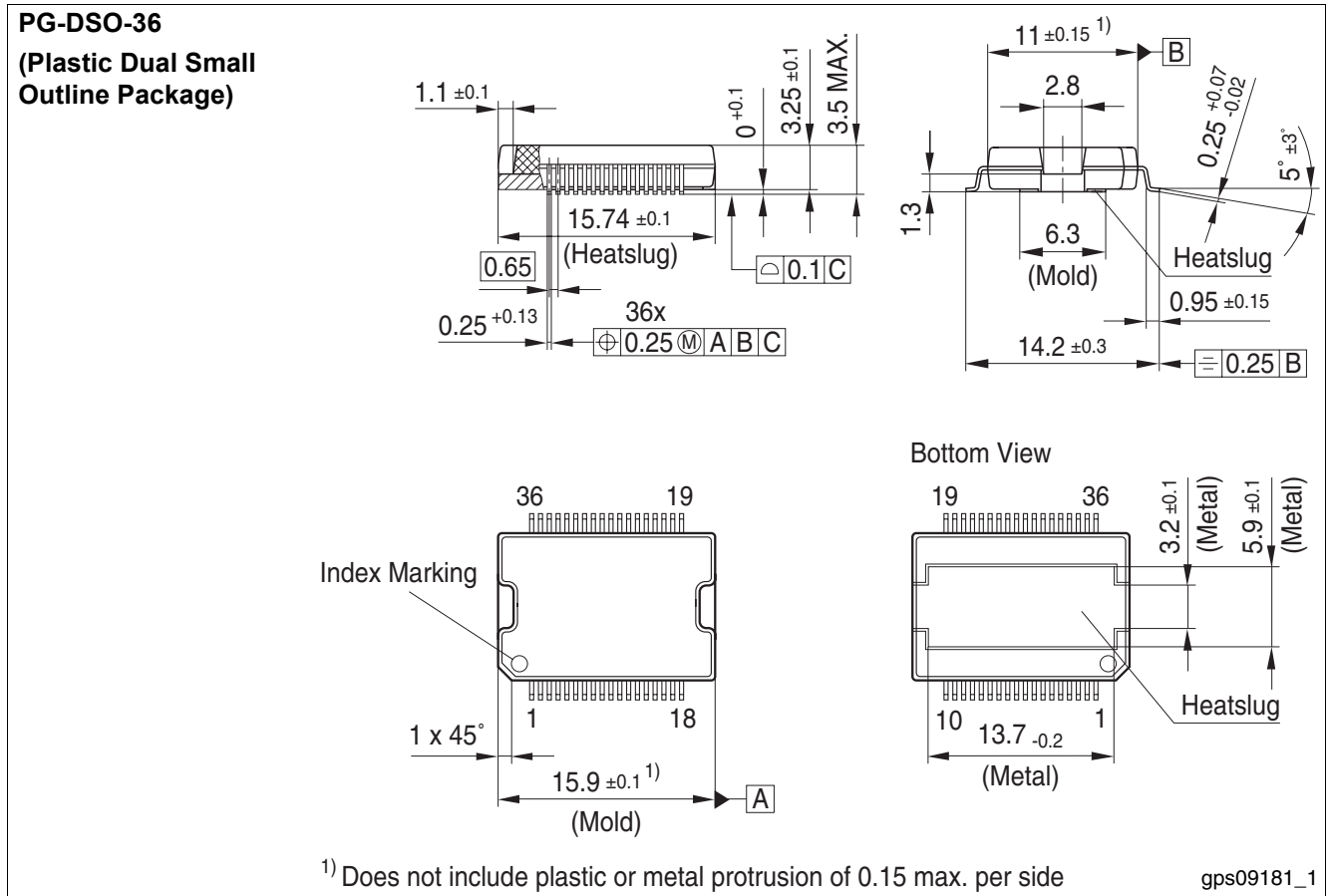
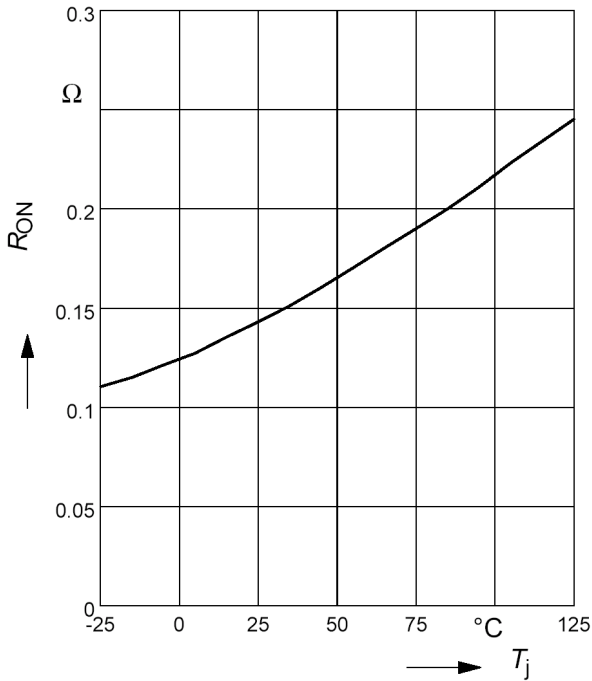


Figure 13 PG-DSO-36

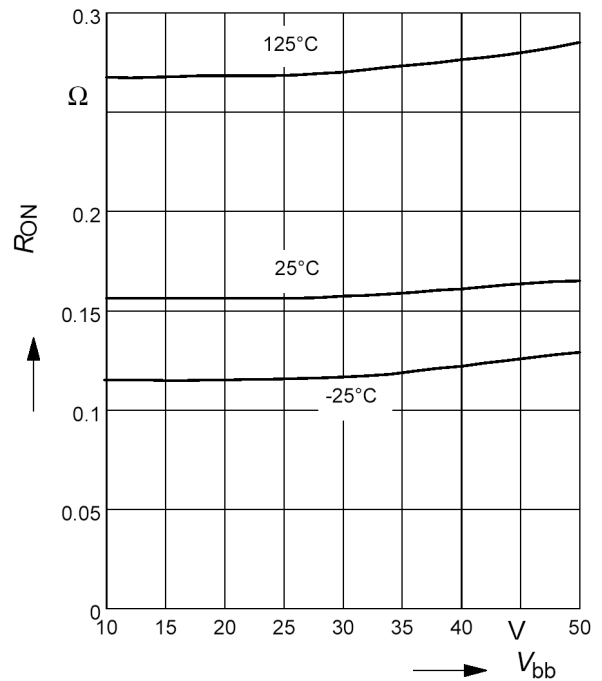
Typ. on-state resistance

$R_{ON} = f(T_j)$ ;  $V_{bb} = 15V$ ;  $V_{in} = \text{high}$



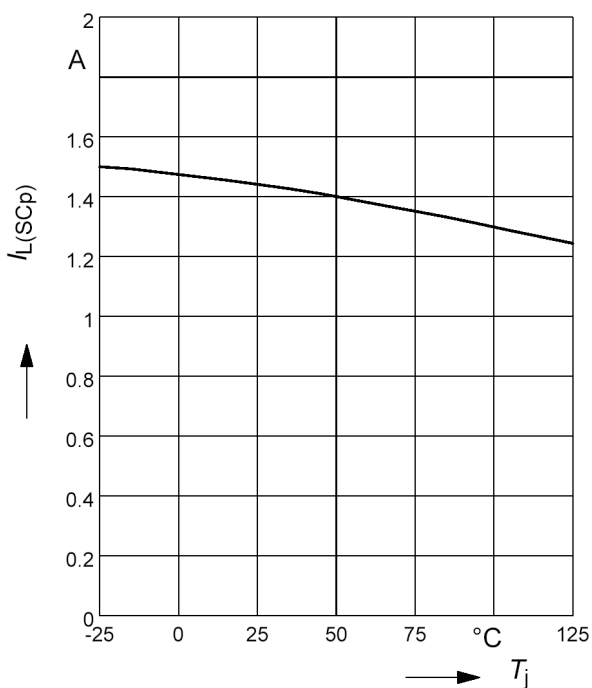
Typ. on-state resistance

$R_{ON} = f(V_{bb})$ ;  $I_L = 0.5A$ ;  $V_{in} = \text{high}$



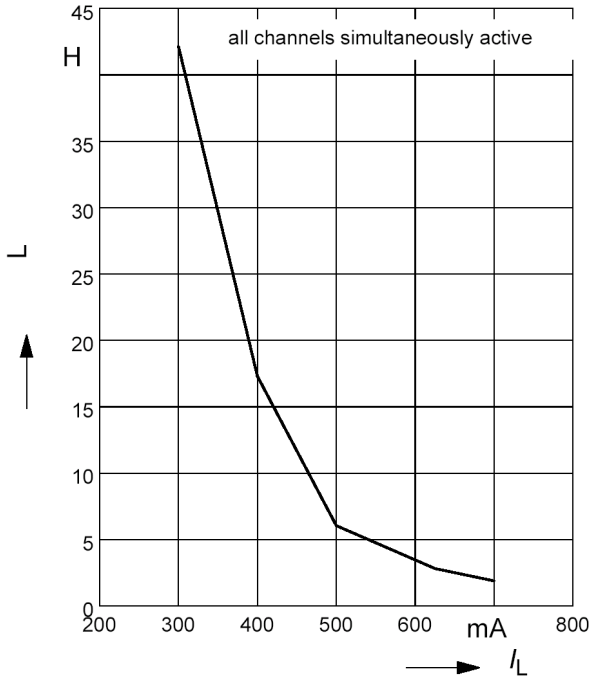
Typ. initial peak short circuit current limit

$I_{L(SCp)} = f(T_j)$ ;  $V_{bb} = 24V$



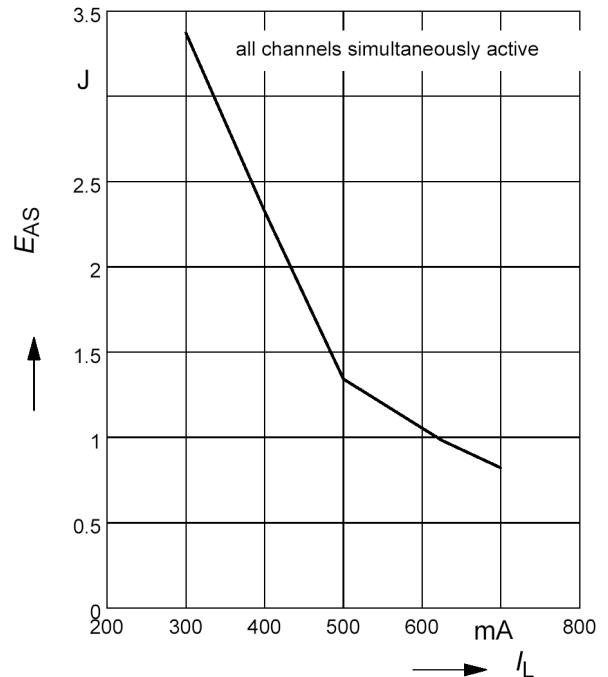
**Maximum allowable load inductance for a single switch off, calculated**

$L = f(I_L); T_{jstart}=125^{\circ}\text{C}, V_{bb}=24\text{V}, R_L=0\Omega$



**Maximum allowable inductive switch-off energy, single pulse**

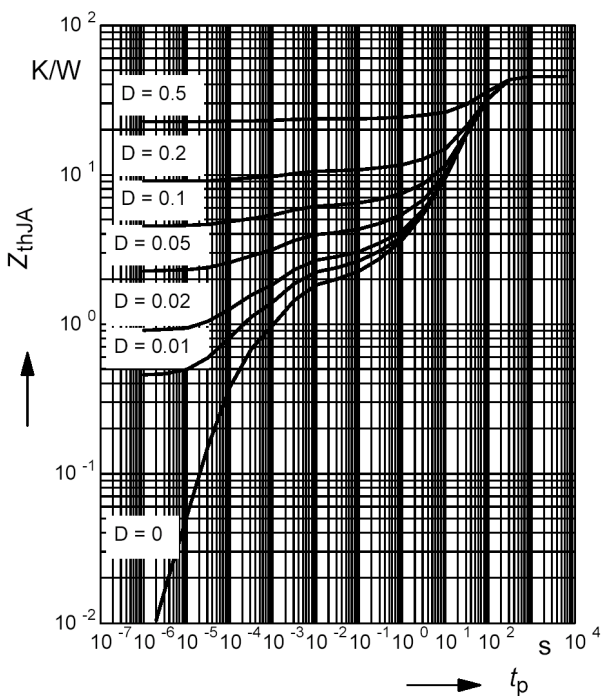
$E_{AS} = f(I_L); T_{jstart} = 125^{\circ}\text{C}, V_{bb} = 24\text{V}$



**Typ. transient thermal impedance**

$Z_{thJA}=f(t_p) @ \text{min. footprint}$

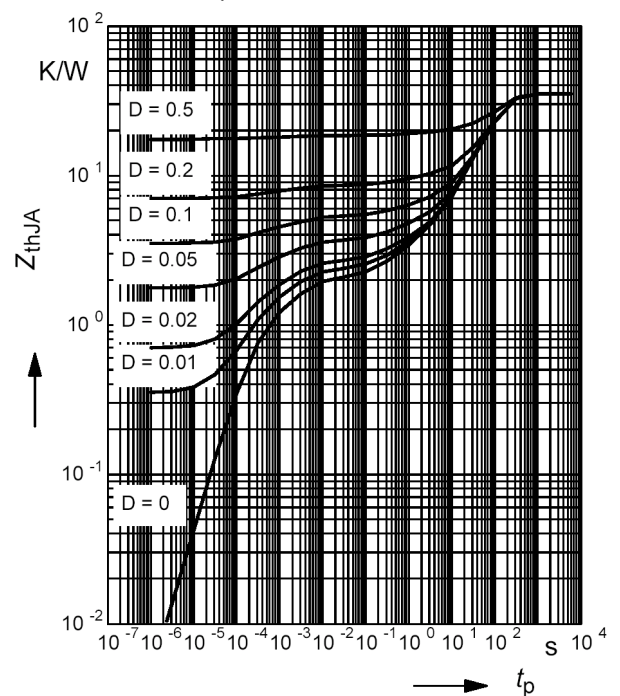
Parameter:  $D=t_p/T$



**Typ. transient thermal impedance**

$Z_{thJA}=f(t_p) @ 6\text{cm}^2 \text{ heatsink area}$

Parameter:  $D=t_p/T$





# Total Quality Management

Qualität hat für uns eine umfassende Bedeutung. Wir wollen allen Ihren Ansprüchen in der bestmöglichen Weise gerecht werden. Es geht uns also nicht nur um die Produktqualität – unsere Anstrengungen gelten gleichermaßen der Lieferqualität und Logistik, dem Service und Support sowie allen sonstigen Beratungs- und Betreuungsleistungen.

Dazu gehört eine bestimmte Geisteshaltung unserer Mitarbeiter. Total Quality im Denken und Handeln gegenüber Kollegen, Lieferanten und Ihnen, unserem Kunden. Unsere Leitlinie ist jede Aufgabe mit „Null Fehlern“ zu lösen – in offener Sichtweise auch über den eigenen Arbeitsplatz hinaus – und uns ständig zu verbessern.

Unternehmensweit orientieren wir uns dabei auch an „top“ (Time Optimized Processes), um Ihnen durch größere Schnelligkeit den entscheidenden Wettbewerbsvorsprung zu verschaffen. Geben Sie uns die Chance, hohe Leistung durch umfassende Qualität zu beweisen.

Wir werden Sie überzeugen.

Quality takes on an all encompassing significance at Semiconductor Group. For us it means living up to each and every one of your demands in the best possible way. So we are not only concerned with product quality. We direct our efforts equally at quality of supply and logistics, service and support, as well as all the other ways in which we advise and attend to you.



Part of this is the very special attitude of our staff. Total Quality in thought and deed, towards co-workers, suppliers and you, our customer. Our guideline is “do everything with zero defects”, in an open manner that is demonstrated beyond your immediate workplace, and to constantly improve.

Throughout the corporation we also think in terms of Time Optimized Processes (top), greater speed on our part to give you that decisive competitive edge.

Give us the chance to prove the best of performance through the best of quality – you will be convinced.

## Looking for pricing, stock, or lifecycle information?

Click below to explore more details on WIN SOURCE:

-  [View ISO1H802G on WIN SOURCE](#)
-  [Infineon Technologies Information](#)

## Optimize Your Supply Chain with WIN SOURCE Solutions

-  Global Sourcing Solution
-  Obsolete Management
-  Cost Control Management
-  Shortage Management
-  Alternative Solution
-  Excess Inventory Management