



**THE DATASHEET OF  
BQ29411PWR**





## VOLTAGE PROTECTION FOR 2-, 3-, OR 4-CELL Li-Ion BATTERIES (2<sup>nd</sup>-LEVEL PROTECTION)

Check for Samples: [bq29410](#), [bq29411](#), [bq29412](#), [bq29413](#), [bq29414](#), [bq29415](#), [bq29419](#)

### FEATURES

- 2-, 3-, or 4-Cell Secondary Protection
- Low Power Consumption  $I_{CC} < 2 \mu A$   
[ $V_{CELL(ALL)} < V_{(PROTECT)}$ ]
- Fixed High Accuracy Overvoltage Protection Threshold
  - bq29410 = 4.35 V
  - bq29411 = 4.40 V
  - bq29412 = 4.45 V
  - bq29413 = 4.50 V
  - bq29414 = 4.55 V
  - bq29415 = 4.60 V
  - bq29419 = 4.30 V
- Programmable Delay Time of Detection
- High Power Supply Ripple Rejection
- Stable During Pulse Charge Operation

### APPLICATIONS

- 2<sup>nd</sup>-Level Overvoltage Protection in Li-Ion Battery Packs in:
  - Notebook Computers
  - Portable Instrumentation
  - Portable Equipment

### DESCRIPTION

The bq2941x is a secondary overvoltage protection IC for 2-, 3-, or 4-cell lithium-ion battery packs that incorporates a high-accuracy precision overvoltage detection circuit. It includes a programmable delay circuit for overvoltage detection time.

### FUNCTION

Each cell in a multiple-cell pack is compared to an internal reference voltage. If one cell reaches an overvoltage condition, the protection sequence begins. The bq2941x device starts charging an external capacitor through the CD pin. When the CD pin voltage reaches 1.2 V, the OUT pin changes from a low level to a high level.

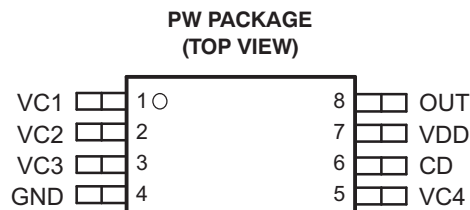
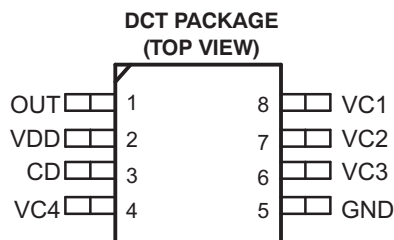

Please be aware that an important notice concerning availability, standard warranty, and use in critical applications of Texas Instruments semiconductor products and disclaimers thereto appears at the end of this data sheet.



This integrated circuit can be damaged by ESD. Texas Instruments recommends that all integrated circuits be handled with appropriate precautions. Failure to observe proper handling and installation procedures can cause damage.

ESD damage can range from subtle performance degradation to complete device failure. Precision integrated circuits may be more susceptible to damage because very small parametric changes could cause the device not to meet its published specifications.

### ORDERING INFORMATION<sup>(1)</sup>

T <sub>A</sub>	V <sub>(PROTECT)</sub> <sup>(2)</sup>	PACKAGE <sup>(3)</sup>			
		MSOP (DCT)	SYMBOL	SSOP (PW)	
–40°C to 110°C	4.30 V	bq29419DCTR	CJQ	bq29419PWG4	bq29419PWRG4
		bq29419DCTT			
	4.35 V	bq29410DCT3R	CJG	bq29410PW bq29410PWG4	bq29410PWR bq29410PWRG4
		bq29410DCTR			
		bq29410DCTT			
	4.40 V	bq29411DCT3R	CJH	bq29411PW bq29411PWG4	bq29411PWR bq29411PWRG4
		bq29411DCTR			
		bq29411DCTT			
	4.45 V	bq29412DCT3R	CJJ	bq29412PW bq29412PWG4	bq29412PWR bq29412PWRG4
		bq29412DCTR			
		bq29412DCTT			
	4.50 V	bq29413DCTR	CJk	bq29413PW	bq29413PWR
		bq29413DCTT			
	4.55 V	bq29414DCTR	CJL	bq29414PW	bq29414PWR
		bq29414DCTT			
	4.60 V	bq29415DCTR	CJM	bq29415PW	bq29415PWR
		bq29415DCTT			

- (1) For the most current package and ordering information, see the Package Option Addendum at the end of this document, or see the TI website at [www.ti.com](http://www.ti.com).
- (2) Contact your local Texas Instruments representative or sales office for alternative overvoltage threshold options.
- (3) The "R" suffix indicates tape-and-reel packaging.

### ABSOLUTE MAXIMUM RATINGS

over operating free-air temperature range unless otherwise noted<sup>(1) (2)</sup>

		UNIT
Supply voltage range	VDD	–0.3 V to 28 V
Input voltage range	VC1, VC2, VC3, VC4	–0.3 V to 28 V
	VC1 TO VC2, VC2 TO VC3, VC3 TO VC4, VC4 TO GND	–0.3 V to 8 V
Output voltage range	OUT	–0.3 V to 28 V
	CD	–0.3 V to 28 V
Continuous total power dissipation		See Dissipation Rating Table
Storage temperature range, T <sub>stg</sub>		–65°C to 150°C
Lead temperature (soldering, 10 s)		300°C

- (1) Stresses beyond those listed under "absolute maximum ratings" may cause permanent damage to the device. These are stress ratings only, and functional operation of the device at these or any other conditions beyond those indicated under "recommended operating conditions" is not implied. Exposure to absolute-maximum-rated conditions for extended periods may affect device reliability.
- (2) All voltages are with respect to ground of this device except the differential voltage of VC1-VC2, VC2-VC3, VC3-VC4, and VC4-GND.

### PACKAGE DISSIPATION RATINGS

PACKAGE	T <sub>A</sub> = 25°C POWER RATING	DERATING FACTOR ABOVE T <sub>A</sub> = 25°C	T <sub>A</sub> = 70°C POWER RATING	T <sub>A</sub> = 85°C POWER RATING
DCT	412 mW	3.3 mW/°C	264 mW	214 mW
PW	525 mW	4.2 mW/°C	336 mW	273 mW

**RECOMMENDED OPERATING CONDITIONS**

		MIN	NOM	MAX	UNIT	
$V_{DD}$	Supply voltage	4		25	V	
$V_I$	Input voltage range	VC1, VC2, VC3, VC4		0	25	V
		VCn – VC (n=1, (n=1, 2, 3), VC4 – GND		0	5	
$t_{d(CD)}$	Delay time capacitance		0.22		$\mu$ F	
$R_{IN}$	Voltage-monitor filter resistance	100	1k		$\Omega$	
$C_{IN}$	Voltage-monitor filter capacitance	0.01	0.1		$\mu$ F	
$R_{VD}$	Supply-voltage filter resistance	0		1	k $\Omega$	
$C_{VD}$	Supply-voltage filter capacitance		0.1		$\mu$ F	
$T_A$	Operating ambient temperature range	–40		110	$^{\circ}$ C	

**ELECTRICAL CHARACTERISTICS**

 over recommended operating free-air temperature range,  $T_A = 25^{\circ}$ C (unless otherwise noted)

PARAMETER	TEST CONDITION	MIN	NOM	MAX	UNIT			
$V_{(OA)}$	Overvoltage detection accuracy	$T_A = 25^{\circ}$ C		25	35	mV		
		$T_A = -20^{\circ}$ C to $85^{\circ}$ C		25	50			
		$T_A = -40^{\circ}$ C to $110^{\circ}$ C			80			
$V_{(PROTECT)}$	Overvoltage detection voltage	bq29410		4.35		V		
		bq29411		4.40				
		bq29412		4.45				
		bq29413		4.50				
		bq29414		4.55				
		bq29415		4.60				
		bq29419		4.30				
$V_{hys}$	Overvoltage detection hysteresis	bq29410/11/12/13/14/15		320		mV		
		bq29419		250	320		450	
$I_{IN}$	Input current	V2, V3, VC4 input, $V_{DD} = VC1$ VC1 = VC2 = VC3 = VC4 = 3.5 V (see Figure 1)			0.3	$\mu$ A		
$t_{D1}$	Overvoltage detection delay time	$V_{DD} = VC1$ , CD = 0.22 $\mu$ F			1	1.5	2	S
$I_{(CD\_dis)}$	CD GND clamp current	$V_{DD} = VC1$ , CD = 1 V			5	12		$\mu$ A
$I_{CC}$	Supply current	$V_{DD} = VC1$ , VC1–VC2 = VC2–VC3 = VC3–VC4 = VC4–GND = 3.5 V (see Figure 1)			2	3		$\mu$ A
		$V_{DD} = VC1$ , VC1–VC2 = VC2–VC3 = VC3–VC4 = VC4–GND = 2.3 V (see Figure 1)			1.5	2.5		
$V_{(OUT)}$	OUT pin drive voltage	VC1–VC2 = VC2–VC3 = VC3–VC4 = VC4–GND = $V_{(PROTECT)Max}$ , $V_{DD} = 14$ V, $I_{OH} = 0$ mA			7			V
		VC1 = VC2 = VC3 = VC4 = $V_{(PROTECT)Max}$ , $V_{DD} = 4.3$ V, $T_A = 0^{\circ}$ C to $70^{\circ}$ C, $I_{OH} = 40$ $\mu$ A			1.5	2	2.5	
$I_{OH}$	High-level output current	OUT = 3 V, VC1–VC2 = VC2–VC3 = VC3–VC4 = VC4–GND = $V_{(PROTECT)Max}$ , $V_{DD} = 14$ V					–1	mA
$I_{OL}$	Low-level output current	OUT = 0.1 V, $V_{DD} = VC1$ , VC1–VC2 = VC2–VC3 = VC3–VC4 = VC4–GND = 3.5 V			5			$\mu$ A

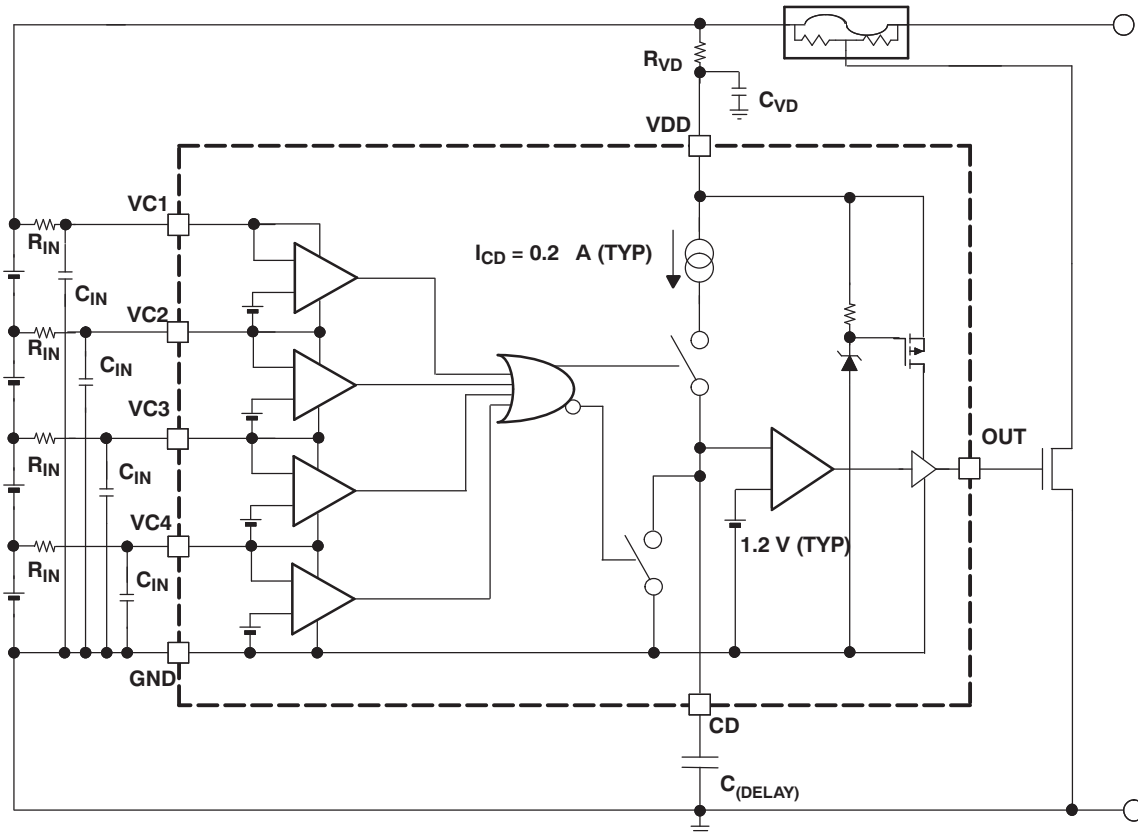

**Figure 1.  $I_{CC}$ ,  $I_{IN}$  Measurement (DCT Package)**

### Terminal Functions

TERMINAL			DESCRIPTION
MSOP (DCT)	TSSOP (PW)	NAME	
8	1	VC1	Sense voltage input for most positive cell
7	2	VC2	Sense voltage input for second most positive cell
6	3	VC3	Sense voltage input for third most positive cell
5	4	GND	Ground pin
4	5	VC4	Sense voltage input for least positive cell
3	6	CD	An external capacitor is connected to determine the programmable delay time
2	7	VDD	Power supply
1	8	OUT	Output

FUNCTIONAL BLOCK DIAGRAM



OVERVOLTAGE PROTECTION

When one of the cell voltages exceeds  $V_{(PROTECT)}$ , an internal current source begins to charge the capacitor,  $C_{(DELAY)}$ , connected to the CD pin. If the voltage at the CD pin,  $V_{CD}$ , reaches 1.2 V, the OUT pin is activated and transitions high. An externally connected NCH FET is activated and blows the external fuse in the positive battery rail; see the functional block diagram.

If all cell voltages fall below  $V_{(PROTECT)}$  before the voltage at pin CD reaches 1.2 V, the delay time does not run out. An internal switch clamps the CD pin to GND and discharges the capacitor,  $C_{(DELAY)}$ , and secures the full delay time for the next occurring overvoltage event.

Once the pin OUT is activated, it transitions back from high to low after all battery cells reach  $V_{(PROTECT)} - V_{hys}$ .

DELAY TIME CALCULATION

The delay time is calculated as follows:

$$t_d = \frac{1.2 \text{ V} \times C_{(DELAY)}}{I_{CD}}$$

$$C_{(DELAY)} = \frac{t_d \times I_{CD}}{1.2 \text{ V}}$$

Where  $I_{(CD)}$  = CD current source = 0.18  $\mu\text{A}$

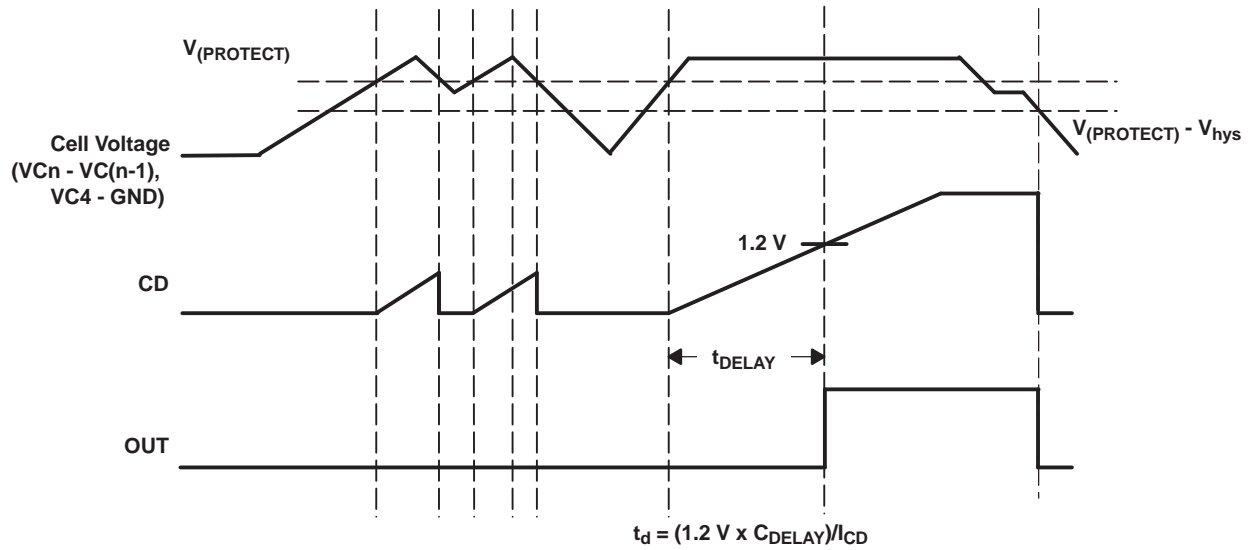

**Figure 2. Timing for Overvoltage Sensing**

## APPLICATION INFORMATION

### BATTERY CONNECTIONS

The following diagrams show the DCT package device in different cell configurations.



**Figure 3. 4-Series Cell Configuration**

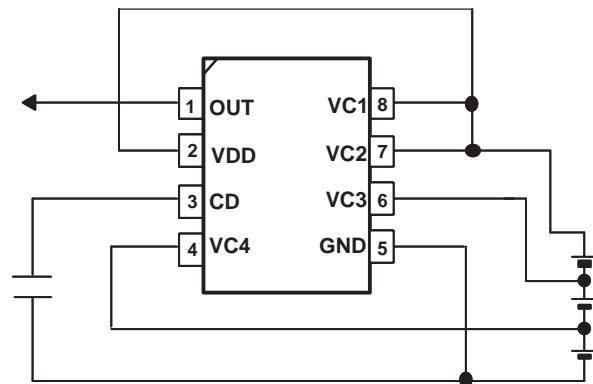

**Figure 4. 3-Series Cell Configuration  
(Connect together VC1 and VC2)**

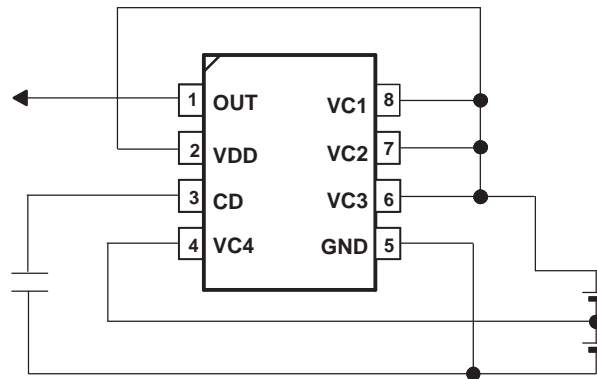

**Figure 5. 2-Series Cell Configuration**

## CELL CONNECTIONS

To prevent incorrect output activation, the following connection sequences must be used.

### 4-Series Cell Configuration

- VC1(=VDD) → VC2 → VC3 → VC4 → GND or
- GND → VC4 → VC3 → VC2 → VC1(=VDD)

### 3-Series Cell Configuration

- VC1(=VC2=VDD) → VC3 → VC4 → GND or
- GND → VC4 → VC3 → VC1(=VC2=VDD)

### 2-Series Cell Configuration

- VC1(=VC2=VC3=VDD) → VC4 → GND or
- GND → VC4 → VC1(=VC2=VC3=VDD)

**PACKAGING INFORMATION**

Orderable Device	Status (1)	Package Type	Package Drawing	Pins	Package Qty	Eco Plan (2)	Lead/Ball Finish (6)	MSL Peak Temp (3)	Op Temp (°C)	Device Marking (4/5)	Samples
BQ29410DCT3R	NRND	SM8	DCT	8	3000	Pb-Free (RoHS)	CU SNBI	Level-1-260C-UNLIM	-40 to 110	CJG W	
BQ29410DCT3RE6	NRND	SM8	DCT	8	3000	Pb-Free (RoHS)	CU SNBI	Level-1-260C-UNLIM	-40 to 110	CJG W	
BQ29410DCTR	NRND	SM8	DCT	8	3000	Green (RoHS & no Sb/Br)	CU NIPDAU	Level-1-260C-UNLIM	-40 to 110	CJG W	
BQ29410DCTRG4	NRND	SM8	DCT	8	3000	Green (RoHS & no Sb/Br)	CU NIPDAU	Level-1-260C-UNLIM	-40 to 110	CJG W	
BQ29410DCTT	NRND	SM8	DCT	8	250	Green (RoHS & no Sb/Br)	CU NIPDAU	Level-1-260C-UNLIM	-40 to 110	CJG W	
BQ29410DCTTG4	NRND	SM8	DCT	8	250	Green (RoHS & no Sb/Br)	CU NIPDAU	Level-1-260C-UNLIM	-40 to 110	CJG W	
BQ29410PW	NRND	TSSOP	PW	8	150	Green (RoHS & no Sb/Br)	CU NIPDAU	Level-1-260C-UNLIM	-40 to 110	29410	
BQ29410PWR	NRND	TSSOP	PW	8	2000	Green (RoHS & no Sb/Br)	CU NIPDAU	Level-1-260C-UNLIM	-40 to 110	29410	
BQ29410PW RG4	NRND	TSSOP	PW	8	2000	Green (RoHS & no Sb/Br)	CU NIPDAU	Level-2-260C-1 YEAR	-40 to 110	29410	
BQ29411DCT3R	NRND	SM8	DCT	8	3000	Pb-Free (RoHS)	CU SNBI	Level-1-260C-UNLIM	-40 to 110	CJH W	
BQ29411DCTR	NRND	SM8	DCT	8	3000	Green (RoHS & no Sb/Br)	CU NIPDAU	Level-1-260C-UNLIM	-40 to 110	CJH W	
BQ29411DCTRG4	NRND	SM8	DCT	8	3000	Green (RoHS & no Sb/Br)	CU NIPDAU	Level-1-260C-UNLIM	-40 to 110	CJH W	
BQ29411DCTT	NRND	SM8	DCT	8	250	Green (RoHS & no Sb/Br)	CU NIPDAU	Level-1-260C-UNLIM	-40 to 110	CJH W	
BQ29411PW	NRND	TSSOP	PW	8	150	Green (RoHS & no Sb/Br)	CU NIPDAU	Level-1-260C-UNLIM	-40 to 110	29411	
BQ29411PW RG4	NRND	TSSOP	PW	8	2000	Green (RoHS & no Sb/Br)	CU NIPDAU	Level-2-260C-1 YEAR	-40 to 110	29411	
BQ29412DCT3R	NRND	SM8	DCT	8	3000	Pb-Free (RoHS)	CU SNBI	Level-1-260C-UNLIM	-40 to 110	CJJ W	
BQ29412DCT3RE6	NRND	SM8	DCT	8	3000	Pb-Free (RoHS)	CU SNBI	Level-1-260C-UNLIM	-40 to 110	CJJ W	

Orderable Device	Status (1)	Package Type	Package Drawing	Pins	Package Qty	Eco Plan (2)	Lead/Ball Finish (6)	MSL Peak Temp (3)	Op Temp (°C)	Device Marking (4/5)	Samples
BQ29412DCTR	NRND	SM8	DCT	8	3000	Green (RoHS & no Sb/Br)	CU NIPDAU	Level-1-260C-UNLIM	-40 to 110	CJJ W	
BQ29412DCTRG4	NRND	SM8	DCT	8	3000	Green (RoHS & no Sb/Br)	CU NIPDAU	Level-1-260C-UNLIM	-40 to 110	CJJ W	
BQ29412DCTT	NRND	SM8	DCT	8	250	Green (RoHS & no Sb/Br)	CU NIPDAU	Level-1-260C-UNLIM	-40 to 110	CJJ W	
BQ29412DCTTG4	NRND	SM8	DCT	8	250	Green (RoHS & no Sb/Br)	CU NIPDAU	Level-1-260C-UNLIM	-40 to 110	CJJ W	
BQ29412PW	NRND	TSSOP	PW	8	150	Green (RoHS & no Sb/Br)	CU NIPDAU	Level-1-260C-UNLIM	-40 to 110	29412	
BQ29412PWR	NRND	TSSOP	PW	8	2000	Green (RoHS & no Sb/Br)	CU NIPDAU	Level-1-260C-UNLIM		29412	
BQ29412PWRG4	NRND	TSSOP	PW	8	2000	Green (RoHS & no Sb/Br)	CU NIPDAU	Level-2-260C-1 YEAR		29412	
BQ29413DCTR	NRND	SM8	DCT	8	3000	Green (RoHS & no Sb/Br)	CU NIPDAU	Level-1-260C-UNLIM	-40 to 110	CJK W	
BQ29413DCTRG4	NRND	SM8	DCT	8	3000	Green (RoHS & no Sb/Br)	CU NIPDAU	Level-1-260C-UNLIM	-40 to 110	CJK W	
BQ29413DCTT	NRND	SM8	DCT	8	250	Green (RoHS & no Sb/Br)	CU NIPDAU	Level-1-260C-UNLIM	-40 to 110	CJK W	
BQ29413PWR	NRND	TSSOP	PW	8	2000	Green (RoHS & no Sb/Br)	CU NIPDAU	Level-2-260C-1 YEAR	-40 to 110	29413	
BQ29415PWR	NRND	TSSOP	PW	8	2000	Green (RoHS & no Sb/Br)	CU NIPDAU	Level-2-260C-1 YEAR	-40 to 110	2915	
BQ29419PW	NRND	TSSOP	PW	8	150	Green (RoHS & no Sb/Br)	CU NIPDAU	Level-2-260C-1 YEAR	-40 to 110	29419	
BQ29419PWG4	NRND	TSSOP	PW	8	150	Green (RoHS & no Sb/Br)	CU NIPDAU	Level-2-260C-1 YEAR	-40 to 110	29419	
BQ29419PWR	NRND	TSSOP	PW	8	2000	Green (RoHS & no Sb/Br)	CU NIPDAU	Level-2-260C-1 YEAR	-40 to 110	29419	

(1) The marketing status values are defined as follows:

**ACTIVE:** Product device recommended for new designs.

**LIFEBUY:** TI has announced that the device will be discontinued, and a lifetime-buy period is in effect.

**NRND:** Not recommended for new designs. Device is in production to support existing customers, but TI does not recommend using this part in a new design.

**PREVIEW:** Device has been announced but is not in production. Samples may or may not be available.

**OBSELETE:** TI has discontinued the production of the device.

<sup>(2)</sup> **RoHS:** TI defines "RoHS" to mean semiconductor products that are compliant with the current EU RoHS requirements for all 10 RoHS substances, including the requirement that RoHS substance do not exceed 0.1% by weight in homogeneous materials. Where designed to be soldered at high temperatures, "RoHS" products are suitable for use in specified lead-free processes. TI may reference these types of products as "Pb-Free".

**RoHS Exempt:** TI defines "RoHS Exempt" to mean products that contain lead but are compliant with EU RoHS pursuant to a specific EU RoHS exemption.

**Green:** TI defines "Green" to mean the content of Chlorine (Cl) and Bromine (Br) based flame retardants meet JS709B low halogen requirements of  $\leq 1000$ ppm threshold. Antimony trioxide based flame retardants must also meet the  $\leq 1000$ ppm threshold requirement.

<sup>(3)</sup> MSL, Peak Temp. - The Moisture Sensitivity Level rating according to the JEDEC industry standard classifications, and peak solder temperature.

<sup>(4)</sup> There may be additional marking, which relates to the logo, the lot trace code information, or the environmental category on the device.

<sup>(5)</sup> Multiple Device Markings will be inside parentheses. Only one Device Marking contained in parentheses and separated by a "-" will appear on a device. If a line is indented then it is a continuation of the previous line and the two combined represent the entire Device Marking for that device.

<sup>(6)</sup> Lead/Ball Finish - Orderable Devices may have multiple material finish options. Finish options are separated by a vertical ruled line. Lead/Ball Finish values may wrap to two lines if the finish value exceeds the maximum column width.

**Important Information and Disclaimer:** The information provided on this page represents TI's knowledge and belief as of the date that it is provided. TI bases its knowledge and belief on information provided by third parties, and makes no representation or warranty as to the accuracy of such information. Efforts are underway to better integrate information from third parties. TI has taken and continues to take reasonable steps to provide representative and accurate information but may not have conducted destructive testing or chemical analysis on incoming materials and chemicals. TI and TI suppliers consider certain information to be proprietary, and thus CAS numbers and other limited information may not be available for release.

In no event shall TI's liability arising out of such information exceed the total purchase price of the TI part(s) at issue in this document sold by TI to Customer on an annual basis.

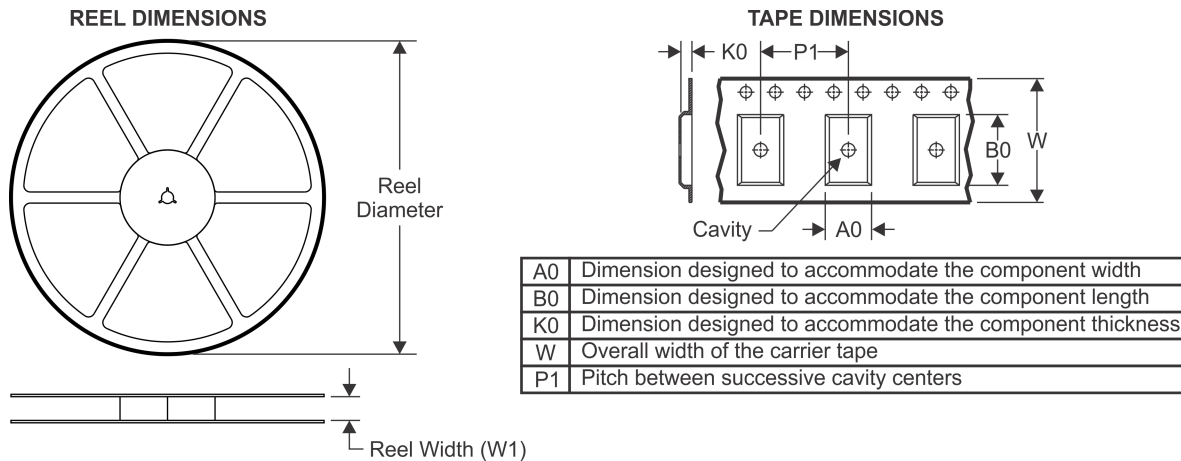
**TAPE AND REEL INFORMATION**

**QUADRANT ASSIGNMENTS FOR PIN 1 ORIENTATION IN TAPE**

\*All dimensions are nominal

Device	Package Type	Package Drawing	Pins	SPQ	Reel Diameter (mm)	Reel Width W1 (mm)	A0 (mm)	B0 (mm)	K0 (mm)	P1 (mm)	W (mm)	Pin1 Quadrant
BQ29410DCT3R	SM8	DCT	8	3000	180.0	13.0	3.35	4.5	1.55	4.0	12.0	Q3
BQ29410DCTR	SM8	DCT	8	3000	180.0	13.0	3.35	4.5	1.55	4.0	12.0	Q3
BQ29410DCTT	SM8	DCT	8	250	180.0	13.0	3.35	4.5	1.55	4.0	12.0	Q3
BQ29410PWR	TSSOP	PW	8	2000	330.0	12.4	7.0	3.6	1.6	8.0	12.0	Q1
BQ29410PWRG4	TSSOP	PW	8	2000	330.0	12.4	7.0	3.6	1.6	8.0	12.0	Q1
BQ29411DCT3R	SM8	DCT	8	3000	180.0	13.0	3.35	4.5	1.55	4.0	12.0	Q3
BQ29411DCTR	SM8	DCT	8	3000	180.0	13.0	3.35	4.5	1.55	4.0	12.0	Q3
BQ29411DCTT	SM8	DCT	8	250	180.0	13.0	3.35	4.5	1.55	4.0	12.0	Q3
BQ29411PWRG4	TSSOP	PW	8	2000	330.0	12.4	7.0	3.6	1.6	8.0	12.0	Q1
BQ29413DCTR	SM8	DCT	8	3000	180.0	13.0	3.35	4.5	1.55	4.0	12.0	Q3
BQ29413DCTT	SM8	DCT	8	250	180.0	13.0	3.35	4.5	1.55	4.0	12.0	Q3
BQ29413PWR	TSSOP	PW	8	2000	330.0	12.4	7.0	3.6	1.6	8.0	12.0	Q1
BQ29415PWR	TSSOP	PW	8	2000	330.0	12.4	7.0	3.6	1.6	8.0	12.0	Q1
BQ29419PWR	TSSOP	PW	8	2000	330.0	12.4	7.0	3.6	1.6	8.0	12.0	Q1

**TAPE AND REEL BOX DIMENSIONS**

\*All dimensions are nominal

Device	Package Type	Package Drawing	Pins	SPQ	Length (mm)	Width (mm)	Height (mm)
BQ29410DCT3R	SM8	DCT	8	3000	182.0	182.0	20.0
BQ29410DCTR	SM8	DCT	8	3000	182.0	182.0	20.0
BQ29410DCTT	SM8	DCT	8	250	182.0	182.0	20.0
BQ29410PWR	TSSOP	PW	8	2000	367.0	367.0	35.0
BQ29410PWRG4	TSSOP	PW	8	2000	367.0	367.0	35.0
BQ29411DCT3R	SM8	DCT	8	3000	182.0	182.0	20.0
BQ29411DCTR	SM8	DCT	8	3000	182.0	182.0	20.0
BQ29411DCTT	SM8	DCT	8	250	182.0	182.0	20.0
BQ29411PWRG4	TSSOP	PW	8	2000	367.0	367.0	35.0
BQ29413DCTR	SM8	DCT	8	3000	182.0	182.0	20.0
BQ29413DCTT	SM8	DCT	8	250	182.0	182.0	20.0
BQ29413PWR	TSSOP	PW	8	2000	367.0	367.0	35.0
BQ29415PWR	TSSOP	PW	8	2000	367.0	367.0	35.0
BQ29419PWR	TSSOP	PW	8	2000	367.0	367.0	35.0

DCT (R-PDSO-G8)

PLASTIC SMALL-OUTLINE PACKAGE

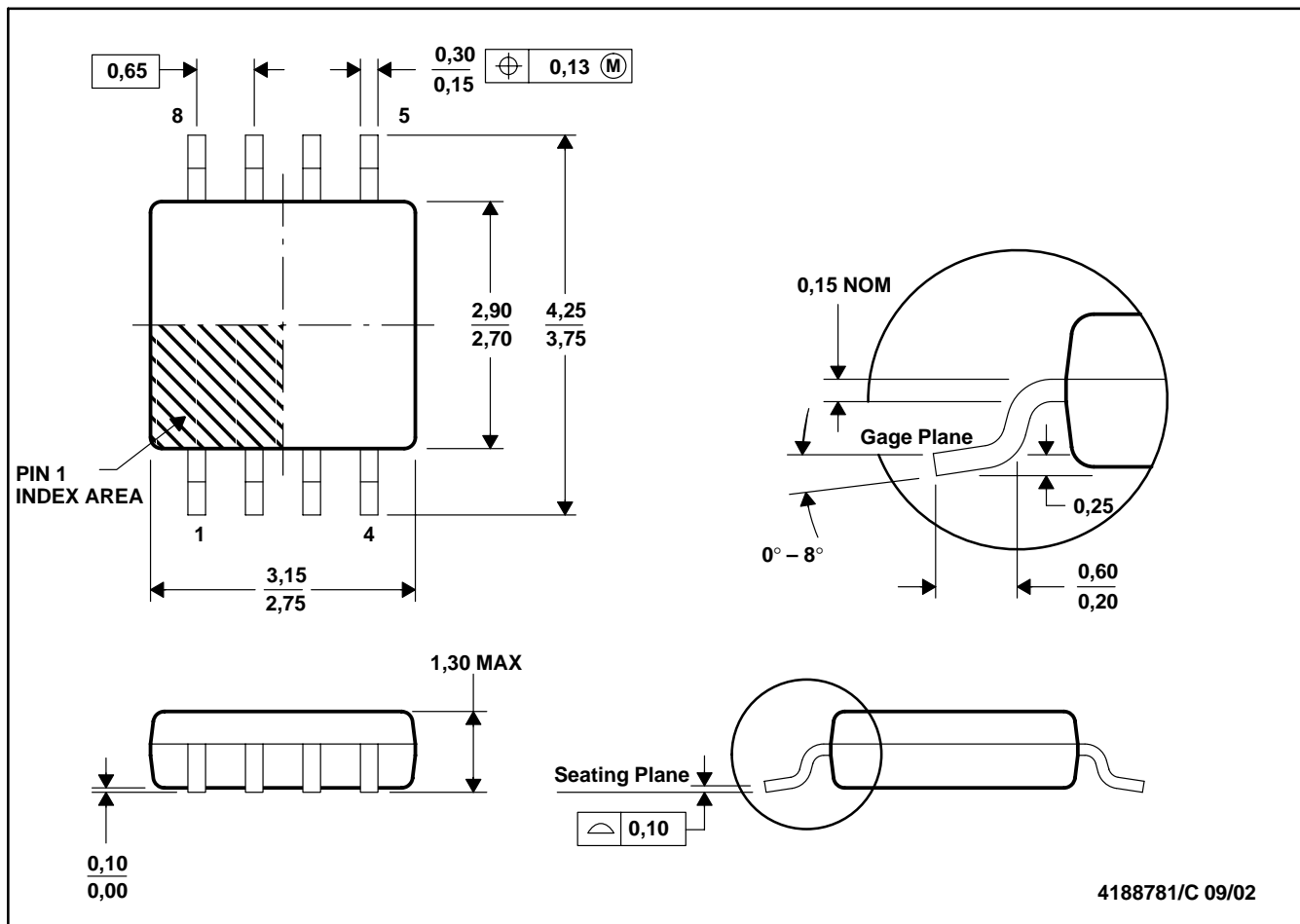

- NOTES:
- A. All linear dimensions are in millimeters.
  - B. This drawing is subject to change without notice.
  - C. Body dimensions do not include mold flash or protrusion
  - D. Falls within JEDEC MO-187 variation DA.

DCT (R-PDSO-G8)

PLASTIC SMALL OUTLINE

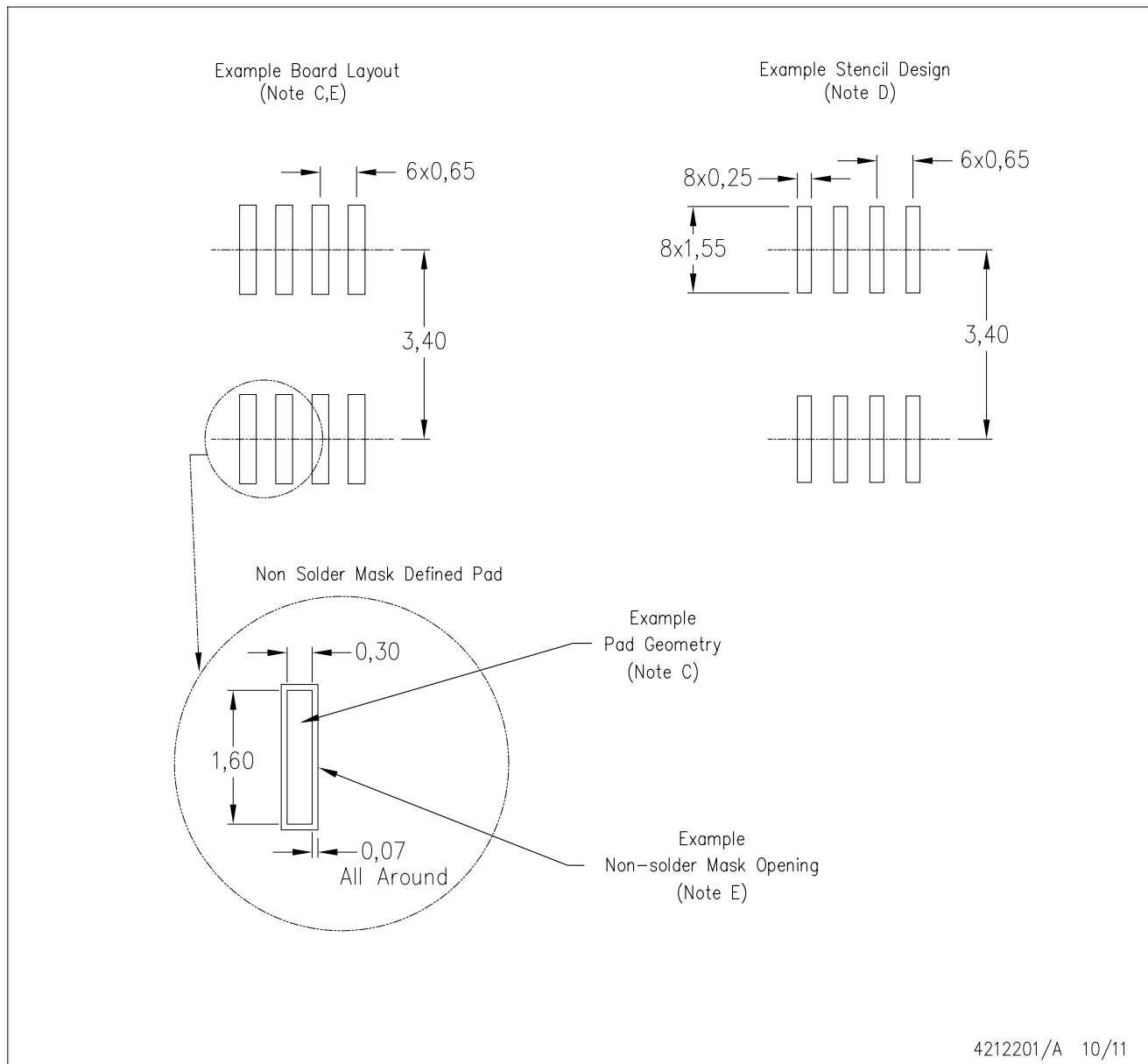

- NOTES: A. All linear dimensions are in millimeters.  
 B. This drawing is subject to change without notice.  
 C. Publication IPC-7351 is recommended for alternate designs.  
 D. Laser cutting apertures with trapezoidal walls and also rounding corners will offer better paste release. Customers should contact their board assembly site for stencil design recommendations. Refer to IPC-7525.  
 E. Customers should contact their board fabrication site for solder mask tolerances between and around signal pads.

PW0008A



PACKAGE OUTLINE  
TSSOP - 1.2 mm max height

SMALL OUTLINE PACKAGE

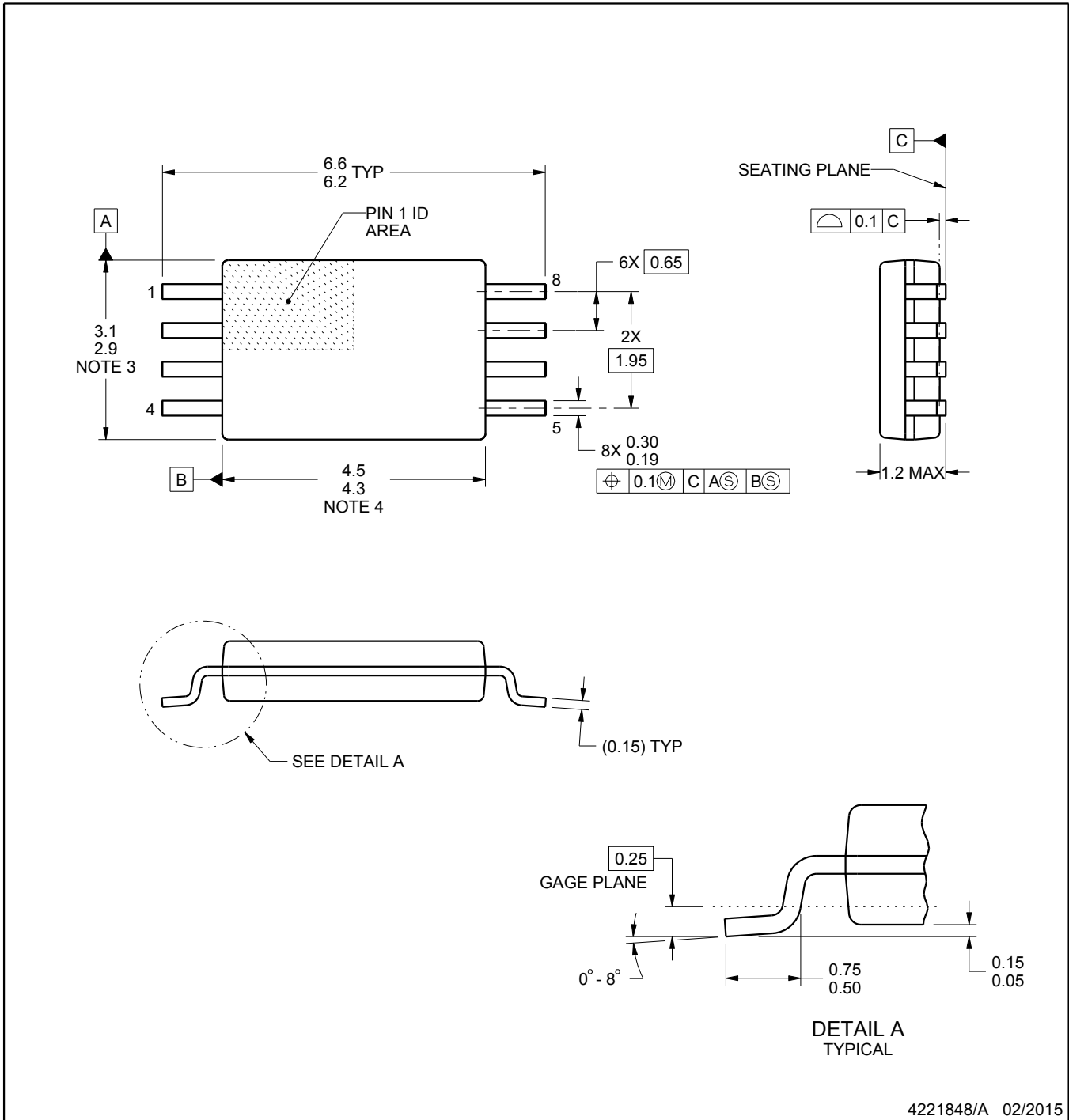

4221848/A 02/2015

NOTES:

1. All linear dimensions are in millimeters. Any dimensions in parenthesis are for reference only. Dimensioning and tolerancing per ASME Y14.5M.
2. This drawing is subject to change without notice.
3. This dimension does not include mold flash, protrusions, or gate burrs. Mold flash, protrusions, or gate burrs shall not exceed 0.15 mm per side.
4. This dimension does not include interlead flash. Interlead flash shall not exceed 0.25 mm per side.
5. Reference JEDEC registration MO-153, variation AA.

# EXAMPLE BOARD LAYOUT

PW0008A

TSSOP - 1.2 mm max height

SMALL OUTLINE PACKAGE

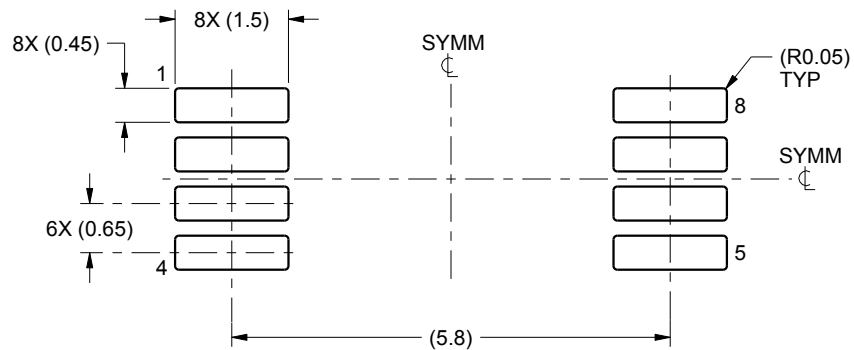

LAND PATTERN EXAMPLE  
SCALE:10X

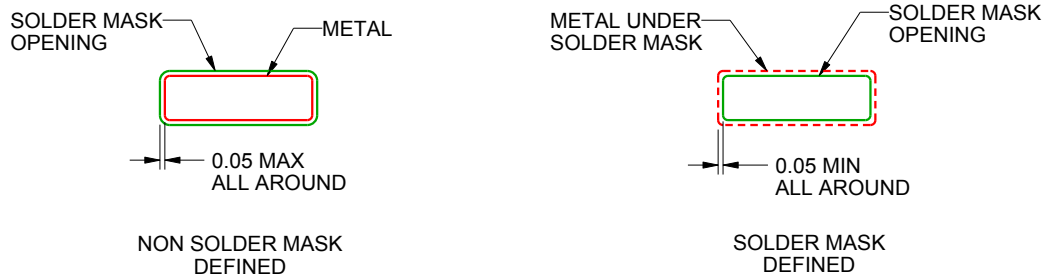

SOLDER MASK DETAILS  
NOT TO SCALE

4221848/A 02/2015

NOTES: (continued)

- 6. Publication IPC-7351 may have alternate designs.
- 7. Solder mask tolerances between and around signal pads can vary based on board fabrication site.

# EXAMPLE STENCIL DESIGN

PW0008A

TSSOP - 1.2 mm max height

SMALL OUTLINE PACKAGE



SOLDER PASTE EXAMPLE  
BASED ON 0.125 mm THICK STENCIL  
SCALE:10X

4221848/A 02/2015

NOTES: (continued)

8. Laser cutting apertures with trapezoidal walls and rounded corners may offer better paste release. IPC-7525 may have alternate design recommendations.
9. Board assembly site may have different recommendations for stencil design.

## IMPORTANT NOTICE

Texas Instruments Incorporated (TI) reserves the right to make corrections, enhancements, improvements and other changes to its semiconductor products and services per JESD46, latest issue, and to discontinue any product or service per JESD48, latest issue. Buyers should obtain the latest relevant information before placing orders and should verify that such information is current and complete.

TI's published terms of sale for semiconductor products (<http://www.ti.com/sc/docs/stdterms.htm>) apply to the sale of packaged integrated circuit products that TI has qualified and released to market. Additional terms may apply to the use or sale of other types of TI products and services.

Reproduction of significant portions of TI information in TI data sheets is permissible only if reproduction is without alteration and is accompanied by all associated warranties, conditions, limitations, and notices. TI is not responsible or liable for such reproduced documentation. Information of third parties may be subject to additional restrictions. Resale of TI products or services with statements different from or beyond the parameters stated by TI for that product or service voids all express and any implied warranties for the associated TI product or service and is an unfair and deceptive business practice. TI is not responsible or liable for any such statements.

Buyers and others who are developing systems that incorporate TI products (collectively, "Designers") understand and agree that Designers remain responsible for using their independent analysis, evaluation and judgment in designing their applications and that Designers have full and exclusive responsibility to assure the safety of Designers' applications and compliance of their applications (and of all TI products used in or for Designers' applications) with all applicable regulations, laws and other applicable requirements. Designer represents that, with respect to their applications, Designer has all the necessary expertise to create and implement safeguards that (1) anticipate dangerous consequences of failures, (2) monitor failures and their consequences, and (3) lessen the likelihood of failures that might cause harm and take appropriate actions. Designer agrees that prior to using or distributing any applications that include TI products, Designer will thoroughly test such applications and the functionality of such TI products as used in such applications.

TI's provision of technical, application or other design advice, quality characterization, reliability data or other services or information, including, but not limited to, reference designs and materials relating to evaluation modules, (collectively, "TI Resources") are intended to assist designers who are developing applications that incorporate TI products; by downloading, accessing or using TI Resources in any way, Designer (individually or, if Designer is acting on behalf of a company, Designer's company) agrees to use any particular TI Resource solely for this purpose and subject to the terms of this Notice.

TI's provision of TI Resources does not expand or otherwise alter TI's applicable published warranties or warranty disclaimers for TI products, and no additional obligations or liabilities arise from TI providing such TI Resources. TI reserves the right to make corrections, enhancements, improvements and other changes to its TI Resources. TI has not conducted any testing other than that specifically described in the published documentation for a particular TI Resource.

Designer is authorized to use, copy and modify any individual TI Resource only in connection with the development of applications that include the TI product(s) identified in such TI Resource. NO OTHER LICENSE, EXPRESS OR IMPLIED, BY ESTOPPEL OR OTHERWISE TO ANY OTHER TI INTELLECTUAL PROPERTY RIGHT, AND NO LICENSE TO ANY TECHNOLOGY OR INTELLECTUAL PROPERTY RIGHT OF TI OR ANY THIRD PARTY IS GRANTED HEREIN, including but not limited to any patent right, copyright, mask work right, or other intellectual property right relating to any combination, machine, or process in which TI products or services are used. Information regarding or referencing third-party products or services does not constitute a license to use such products or services, or a warranty or endorsement thereof. Use of TI Resources may require a license from a third party under the patents or other intellectual property of the third party, or a license from TI under the patents or other intellectual property of TI.

TI RESOURCES ARE PROVIDED "AS IS" AND WITH ALL FAULTS. TI DISCLAIMS ALL OTHER WARRANTIES OR REPRESENTATIONS, EXPRESS OR IMPLIED, REGARDING RESOURCES OR USE THEREOF, INCLUDING BUT NOT LIMITED TO ACCURACY OR COMPLETENESS, TITLE, ANY EPIDEMIC FAILURE WARRANTY AND ANY IMPLIED WARRANTIES OF MERCHANTABILITY, FITNESS FOR A PARTICULAR PURPOSE, AND NON-INFRINGEMENT OF ANY THIRD PARTY INTELLECTUAL PROPERTY RIGHTS. TI SHALL NOT BE LIABLE FOR AND SHALL NOT DEFEND OR INDEMNIFY DESIGNER AGAINST ANY CLAIM, INCLUDING BUT NOT LIMITED TO ANY INFRINGEMENT CLAIM THAT RELATES TO OR IS BASED ON ANY COMBINATION OF PRODUCTS EVEN IF DESCRIBED IN TI RESOURCES OR OTHERWISE. IN NO EVENT SHALL TI BE LIABLE FOR ANY ACTUAL, DIRECT, SPECIAL, COLLATERAL, INDIRECT, PUNITIVE, INCIDENTAL, CONSEQUENTIAL OR EXEMPLARY DAMAGES IN CONNECTION WITH OR ARISING OUT OF TI RESOURCES OR USE THEREOF, AND REGARDLESS OF WHETHER TI HAS BEEN ADVISED OF THE POSSIBILITY OF SUCH DAMAGES.

Unless TI has explicitly designated an individual product as meeting the requirements of a particular industry standard (e.g., ISO/TS 16949 and ISO 26262), TI is not responsible for any failure to meet such industry standard requirements.

Where TI specifically promotes products as facilitating functional safety or as compliant with industry functional safety standards, such products are intended to help enable customers to design and create their own applications that meet applicable functional safety standards and requirements. Using products in an application does not by itself establish any safety features in the application. Designers must ensure compliance with safety-related requirements and standards applicable to their applications. Designer may not use any TI products in life-critical medical equipment unless authorized officers of the parties have executed a special contract specifically governing such use. Life-critical medical equipment is medical equipment where failure of such equipment would cause serious bodily injury or death (e.g., life support, pacemakers, defibrillators, heart pumps, neurostimulators, and implantables). Such equipment includes, without limitation, all medical devices identified by the U.S. Food and Drug Administration as Class III devices and equivalent classifications outside the U.S.

TI may expressly designate certain products as completing a particular qualification (e.g., Q100, Military Grade, or Enhanced Product). Designers agree that it has the necessary expertise to select the product with the appropriate qualification designation for their applications and that proper product selection is at Designers' own risk. Designers are solely responsible for compliance with all legal and regulatory requirements in connection with such selection.

Designer will fully indemnify TI and its representatives against any damages, costs, losses, and/or liabilities arising out of Designer's non-compliance with the terms and provisions of this Notice.

## Looking for pricing, stock, or lifecycle information?

Click below to explore more details on WIN SOURCE:

 [View BQ29411PWR](#) on WIN SOURCE

 [Texas Instruments](#) Information

## Optimize Your Supply Chain with WIN SOURCE Solutions

-  Global Sourcing Solution
-  Obsolete Management
-  Cost Control Management
-  Shortage Management
-  Alternative Solution
-  Excess Inventory Management