



THE DATASHEET OF INA250A2PWR



INA250 36-V, Bidirectional, Precision Current Sense Amplifier With Integrated Shunt Resistor

1 Features

- Precision Integrated Shunt Resistor:
 - Shunt Resistor: 2 mΩ
 - Shunt Resistor Tolerance: 0.1% (Max)
 - 15 A Continuous from –40°C to 85°C
 - 0°C to 125°C Temperature Coefficient: 10 ppm/°C
- High Accuracy:
 - Gain Error (Shunt and Amplifier): 0.3% (Max)
 - Offset Current: 50 mA (Max, INA250A2)
- Four Available Gains:
 - INA250A1: 200 mV/A
 - INA250A2: 500 mV/A
 - INA250A3: 800 mV/A
 - INA250A4: 2 V/A
- Wide Common-Mode Range: –0.1 V to 36 V
- Specified Operating Temperature: –40°C to 125°C

2 Applications

- Test Equipment
- Power Supplies
- Servers
- Telecom Equipment
- Automotive
- Solar Inverters
- Power Management

3 Description

The INA250 is a voltage-output, current-sensing amplifier family that integrates an internal shunt resistor to enable high-accuracy current measurements at common-mode voltages that can vary from 0 V to 36 V, independent of the supply voltage. The device is a bidirectional, low- or high-side current-shunt monitor that allows an external reference to be used to measure current flowing in both directions through the internal current-sensing resistor sensor. The integration of the precision current-sensing resistor provides calibration equivalent measurement accuracy with ultra-low temperature drift performance and ensures an optimized Kelvin layout for the sensing resistor is always obtained.

The INA250 family is available in four output voltage scales: 200 mV/A, 500 mV/A, 800 mV/A, and 2 V/A. This device is fully tested and specified for continuous currents up to 10 amps at the maximum temperature of 125°C. The INA250 operates from a single 2.7-V to 36-V supply and draws a maximum of 300 μA of supply current. All INA250 gain versions are specified over the extended operating temperature range (–40°C to 125°C), and are available in a TSSOP-16 package.

Package Information

PART NUMBER	PACKAGE ⁽¹⁾	PACKAGE SIZE ⁽²⁾
INA250A1	PW (TSSOP, 16)	5.00 mm × 6.40 mm
INA250A2		
INA250A3		
INA250A4		

- (1) For all available packages, see the orderable addendum at the end of the datasheet.
- (2) The package size (length × width) is a nominal value and includes pins, where applicable.

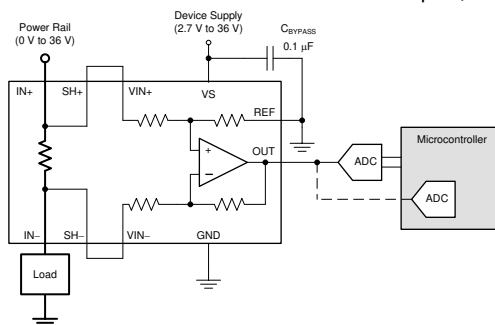

Simplified Schematic



Table of Contents

1 Features	1	7.4 Device Functional Modes.....	15
2 Applications	1	8 Applications and Implementation	19
3 Description	1	8.1 Application Information.....	19
4 Revision History	2	8.2 Typical Applications.....	19
5 Pin Configuration and Functions	3	8.3 Power Supply Recommendations.....	23
6 Specifications	4	8.4 Layout.....	23
6.1 Absolute Maximum Ratings.....	4	9 Device and Documentation Support	26
6.2 ESD Ratings.....	4	9.1 Documentation Support.....	26
6.3 Recommended Operating Conditions.....	4	9.2 Receiving Notification of Documentation Updates....	26
6.4 Thermal Information.....	4	9.3 Support Resources.....	26
6.5 Electrical Characteristics.....	5	9.4 Trademarks.....	26
6.6 Typical Characteristics.....	7	9.5 Electrostatic Discharge Caution.....	26
7 Detailed Description	12	9.6 Glossary.....	26
7.1 Overview.....	12	10 Mechanical, Packaging, and Orderable Information	26
7.2 Functional Block Diagram.....	12		
7.3 Feature Description.....	12		

4 Revision History

Changes from Revision B (December 2015) to Revision C (September 2023)	Page
• Changed the numbering format for tables, figures, and cross-references throughout the document.....	1
• Changed the <i>Device Information</i> table to <i>Package Information</i>	1
• Changed the <i>Shunt resistance (SH+ to SH-)</i> minimum value for use as stand-alone resistor from: 1.9 mΩ to 1.8 mΩ in the <i>Electrical Characteristics</i> table.....	5
• Changed the <i>Shunt resistance (SH+ to SH-)</i> minimum value for use as stand-alone resistor from: 2.1 mΩ to 2.2 mΩ in the <i>Electrical Characteristics</i> table.....	5
Changes from Revision A (May 2015) to Revision B (December 2015)	Page
• Released INA250A1, INA250A3, and INA250A4 to production.....	1
• Added TI Design	1
• Added parameters for INA250A1, INA250A3, and INA250A4 to <i>Electrical Characteristics</i> table.....	5
• Added ± to specifications for the <i>Shunt short time overload</i> , <i>Shunt thermal shock</i> , <i>Shunt resistance to solder heat</i> , <i>Shunt high temperature exposure</i> , and <i>Shunt cold temperature storage</i> parameters of <i>Electrical Characteristics</i> table.....	5
• Added curves for INA250A1, INA250A3, and INA250A4 to <i>Typical Characteristics</i> section	7
• Added <i>Amplifier Operation</i> section	15
Changes from Revision * (April 2015) to Revision A (May 2015)	Page
• INA250A2 released to production.....	1

5 Pin Configuration and Functions

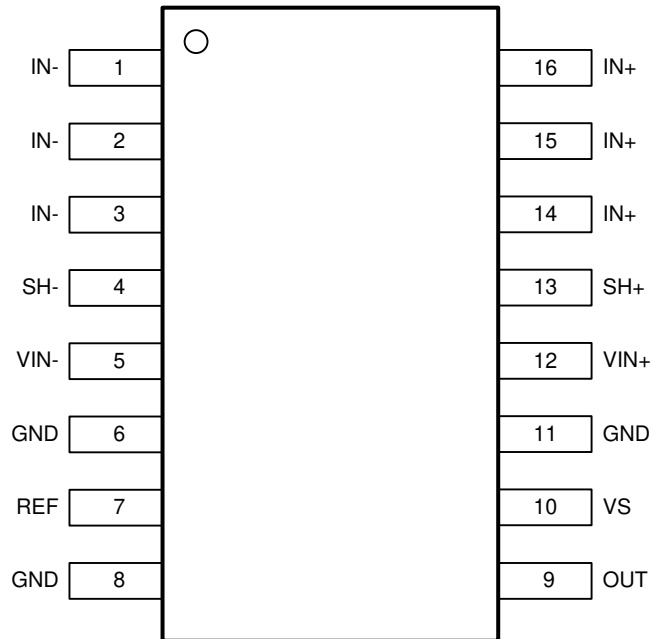

Figure 5-1. PW Package 16-Pin TSSOP Top View

Table 5-1. Pin Functions

PIN		I/O	DESCRIPTION
NAME	NO.		
GND	6, 8, 11	Analog	Ground
IN-	1, 2, 3	Analog input	Connect to load
IN+	14, 15, 16	Analog input	Connect to supply
OUT	9	Analog output	Output voltage
REF	7	Analog input	Reference voltage, 0 V to VS (up to 18 V)
SH-	4	Analog output	Kelvin connection to internal shunt. Connect to VIN- if no filtering is needed. See Figure 7-4 for filter recommendations.
SH+	13	Analog output	Kelvin connection to internal shunt. Connect to VIN+ if no filtering is needed. See Figure 7-4 for filter recommendations.
VIN-	5	Analog input	Voltage input from load side of shunt resistor.
VIN+	12	Analog input	Voltage input from supply side of shunt resistor.
VS	10	Analog	Device power supply, 2.7 V to 36 V

6 Specifications

6.1 Absolute Maximum Ratings

over operating free-air temperature range (unless otherwise noted)⁽¹⁾

		MIN	MAX	UNIT
Supply voltage (VS)			40	V
Analog input current	Continuous current		±15	A
Analog inputs (IN+, IN-)	Common-mode	GND – 0.3	40	V
Analog inputs (VIN+, VIN-)	Common-mode	GND – 0.3	40	V
	Differential (VIN+) – (VIN-)	–40	40	
Analog inputs (REF)		GND – 0.3	VS + 0.3	V
Analog outputs (SH+, SH-)	Common-mode	GND – 0.3	40	V
Analog outputs (OUT)		GND – 0.3	(VS + 0.3) up to 18	V
Temperature	Operating, TA	–55	150	°C
	Junction, TJ		150	
	Storage, Tstg	–65	150	

- (1) Stresses above these ratings may cause permanent damage. Exposure to absolute maximum conditions for extended periods may degrade device reliability. These are stress ratings only, and functional operation of the device at these or any other conditions beyond those specified is not implied.

6.2 ESD Ratings

		VALUE	UNIT
V(ESD)	Electrostatic discharge	Human-body model (HBM), per ANSI/ESDA/JEDEC JS-001 ⁽¹⁾	±2000
		Charged-device model (CDM), per JEDEC specification JESD22-C101 ⁽²⁾	±1000

- (1) JEDEC document JEP155 states that 500-V HBM allows safe manufacturing with a standard ESD control process.
(2) JEDEC document JEP157 states that 250-V CDM allows safe manufacturing with a standard ESD control process.

6.3 Recommended Operating Conditions

		MIN	NOM	MAX	UNIT
VCM	Common-mode input voltage	0		36	V
VS	Operating supply voltage	2.7		36	V
TA	Operating free-air temperature	–40		125	°C

6.4 Thermal Information

THERMAL METRIC ⁽¹⁾		INA250	UNIT
		PW (TSSOP)	
		16 PINS	
RθJA	Junction-to-ambient thermal resistance	104.4	°C/W
RθJC(top)	Junction-to-case (top) thermal resistance	42.3	°C/W
RθJB	Junction-to-board thermal resistance	48.5	°C/W
ψJT	Junction-to-top characterization parameter	4.5	°C/W
ψJB	Junction-to-board characterization parameter	48	°C/W
RθJC(bot)	Junction-to-case (bottom) thermal resistance	N/A	°C/W

- (1) For more information about traditional and new thermal metrics, see the *IC Package Thermal Metrics* application report, [SPRA953](#).

6.5 Electrical Characteristics

At $T_A = 25^\circ\text{C}$, $V_S = 5\text{ V}$, $V_{IN+} = 12\text{ V}$, $V_{REF} = 2.5\text{ V}$, $I_{SENSE} = I_{IN+} = 0\text{ A}$, unless otherwise noted.

PARAMETER		CONDITIONS	MIN	TYP	MAX	UNIT
INPUT						
V_{CM}	Common-mode input range		-0.1		36	V
CMR	Common-mode rejection	INA250A1, $V_{IN+} = 0\text{ V to }36\text{ V}$, $T_A = -40^\circ\text{C to }125^\circ\text{C}$	94	102		dB
		INA250A2, $V_{IN+} = 0\text{ V to }36\text{ V}$, $T_A = -40^\circ\text{C to }125^\circ\text{C}$	97	110		
		INA250A3, $V_{IN+} = 0\text{ V to }36\text{ V}$, $T_A = -40^\circ\text{C to }125^\circ\text{C}$	106	114		
		INA250A4, $V_{IN+} = 0\text{ V to }36\text{ V}$, $T_A = -40^\circ\text{C to }125^\circ\text{C}$	108	118		
I_{OS}	Offset current, RTI ⁽¹⁾	INA250A1, $I_{SENSE} = 0\text{ A}$		± 15	± 100	mA
		INA250A2, $I_{SENSE} = 0\text{ A}$		± 12.5	± 50	
		INA250A3, $I_{SENSE} = 0\text{ A}$		± 5	± 30	
		INA250A4, $I_{SENSE} = 0\text{ A}$		± 5	± 20	
dI_{OS}/dT	RTI versus temperature	$T_A = -40^\circ\text{C to }125^\circ\text{C}$		25	250	$\mu\text{A}/^\circ\text{C}$
PSR		$V_S = 2.7\text{ V to }36\text{ V}$, $T_A = -40^\circ\text{C to }125^\circ\text{C}$		± 0.03	± 1	mAV
I_B	Input bias current	I_{B+} , I_{B-} , $I_{SENSE} = 0\text{ A}$		± 28	± 35	μA
V_{REF}	Reference input range ⁽³⁾		0		(V_S) up to 18	V
SHUNT RESISTOR⁽⁵⁾						
R_{SHUNT}	Shunt resistance (SH+ to SH-)	Equivalent resistance when used with onboard amplifier	1.998	2	2.002	m Ω
		Used as stand-alone resistor ⁽⁷⁾	1.8	2	2.2	
	Package resistance	IN+ to IN-		4.5		m Ω
	Resistor temperature coefficient	$T_A = -40^\circ\text{C to }125^\circ\text{C}$		15		ppm/ $^\circ\text{C}$
$T_A = -40^\circ\text{C to }0^\circ\text{C}$			50			
$T_A = 0^\circ\text{C to }125^\circ\text{C}$			10			
I_{SENSE}	Maximum continuous current ⁽⁴⁾	$T_A = -40^\circ\text{C to }85^\circ\text{C}$			± 15	A
	Shunt short time overload	$I_{SENSE} = 30\text{ A}$ for 5 seconds		$\pm 0.05\%$		
	Shunt thermal shock	$-65^\circ\text{C to }150^\circ\text{C}$, 500 cycles		$\pm 0.1\%$		
	Shunt resistance to solder heat	260°C solder, 10 s		$\pm 0.1\%$		
	Shunt high temperature exposure	1000 hours, $T_A = 150^\circ\text{C}$		$\pm 0.15\%$		
	Shunt cold temperature storage	24 hours, $T_A = -65^\circ\text{C}$		$\pm 0.025\%$		

INA250A1, INA250A2, INA250A3, INA250A4

SBOS511C – APRIL 2015 – REVISED SEPTEMBER 2023

 At $T_A = 25^\circ\text{C}$, $V_S = 5\text{ V}$, $V_{IN+} = 12\text{ V}$, $V_{REF} = 2.5\text{ V}$, $I_{SENSE} = I_{N+} = 0\text{ A}$, unless otherwise noted.

PARAMETER		CONDITIONS	MIN	TYP	MAX	UNIT
OUTPUT						
G	Gain	INA250A1		200		mV/A
		INA250A2		500		
		INA250A3		800		
		INA250A4		2		V/A
	System gain error ⁽⁶⁾	$I_{SENSE} = -10\text{ A to }10\text{ A}$, $T_A = 25^\circ\text{C}$		$\pm 0.05\%$	$\pm 0.3\%$	ppm/°C
		$I_{SENSE} = -10\text{ A to }10\text{ A}$, $T_A = -40^\circ\text{C to }125^\circ\text{C}$			$\pm 0.75\%$	
		$T_A = -40^\circ\text{C to }125^\circ\text{C}$			45	
	Nonlinearity error	$I_{SENSE} = 0.5\text{ A to }10\text{ A}$		$\pm 0.03\%$		
R _O	Output impedance			1.5		Ω
	Maximum capacitive load	No sustained oscillation		1		nF
VOLTAGE OUTPUT⁽²⁾						
	Swing to VS power-supply rail	$R_L = 10\text{ k}\Omega$ to GND		$(V_S) - 0.1$	$(V_S) - 0.2$	V
	Swing to GND	$R_L = 10\text{ k}\Omega$ to GND		$(V_{GND}) + 25$	$(V_{GND}) + 50$	mV
FREQUENCY RESPONSE						
BW	Bandwidth	INA250A1, $C_L = 10\text{ pF}$		50		kHz
		INA250A2, $C_L = 10\text{ pF}$		50		
		INA250A3, $C_L = 10\text{ pF}$		35		
		INA250A4, $C_L = 10\text{ pF}$		11		
SR	Slew rate	$C_L = 10\text{ pF}$		0.2		V/μs
NOISE, RTI⁽¹⁾						
	Voltage noise density	INA250A1		51		nV/√Hz
		INA250A2		35		
		INA250A3		37		
		INA250A4		27		
POWER SUPPLY						
V _S	Operating voltage range		2.7		36	V
I _Q	Quiescent current	$T_A = -40^\circ\text{C to }125^\circ\text{C}$		200	300	μA
TEMPERATURE RANGE						
	Specified range		-40		125	°C

- (1) RTI = referred-to-input.
- (2) See *Typical Characteristics* curve, *Output Voltage Swing vs Output Current* (Figure 6-19).
- (3) The supply voltage range maximum is 36 V, but the reference voltage cannot be higher than 18 V.
- (4) See Figure 7-1 and the *Layout* section for additional information on the current derating and layout recommendations to improve the current handling capability of the device at higher temperatures.
- (5) See the *Section 7.3.1* section for additional information regarding the integrated current-sensing resistor.
- (6) System gain error includes amplifier gain error and the integrated sense resistor tolerance. System gain error does not include the stress related characteristics of the integrated sense resistor. These characteristics are described in the *Shunt Resistor* section of the *Electrical Characteristics* table.
- (7) The internal shunt resistor is intended to be used with the internal amplifier and is not intended to be used as a stand-alone resistor. See the *Integrated Shunt Resistor* section for more information.

6.6 Typical Characteristics

At $T_A = 25^\circ\text{C}$, $V_S = 5\text{ V}$, $V_{IN+} = 12\text{ V}$, $V_{REF} = 2.5\text{ V}$, $I_{SENSE} = I_{IN+} = 0\text{ A}$, unless otherwise noted.

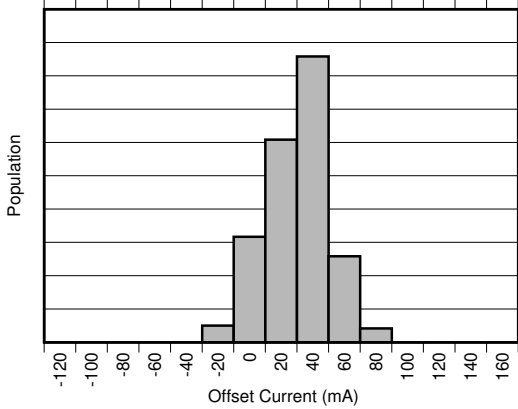

Figure 6-1. INA250A1 Input Offset Distribution

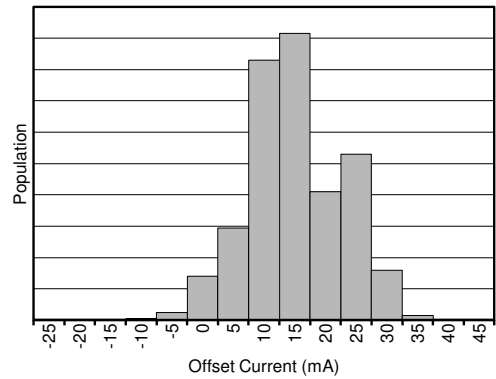

Figure 6-2. INA250A2 Input Offset Distribution

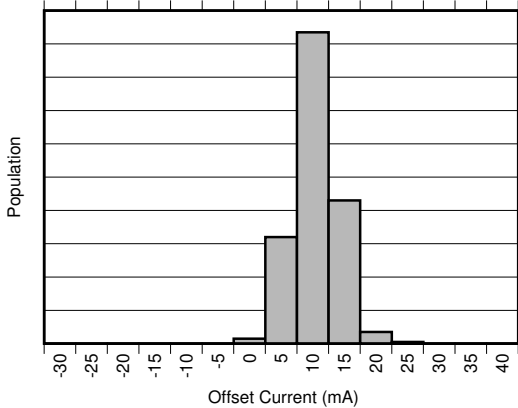

Figure 6-3. INA250A3 Input Offset Distribution

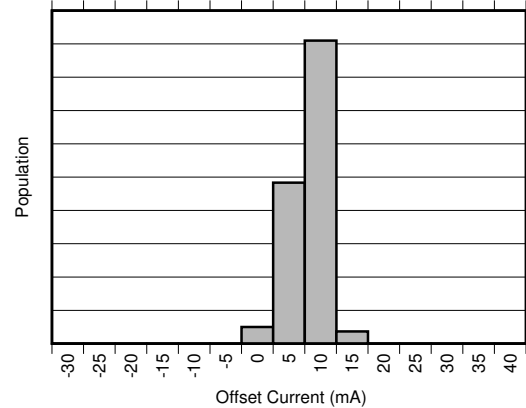

Figure 6-4. INA250A4 Input Offset Distribution

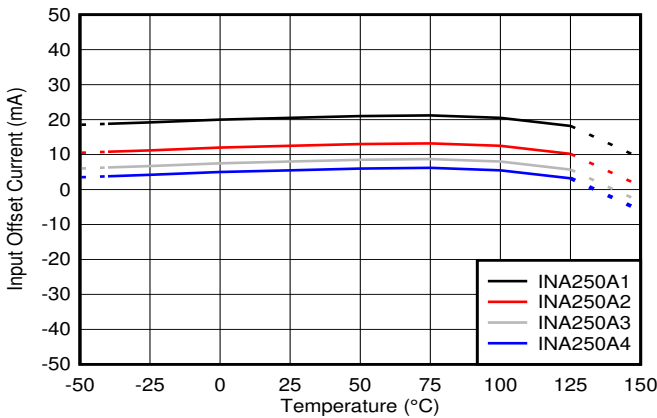

Figure 6-5. Input Offset vs Temperature

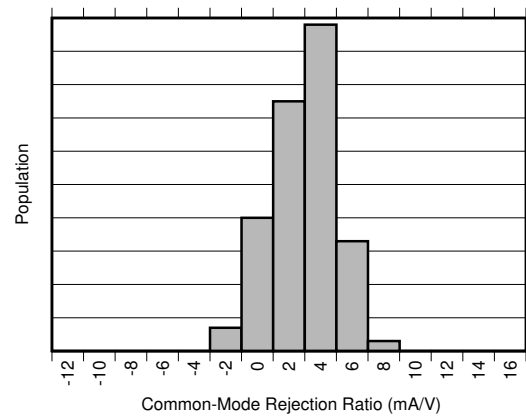

Figure 6-6. INA250A1 Common-Mode Rejection Ratio Distribution

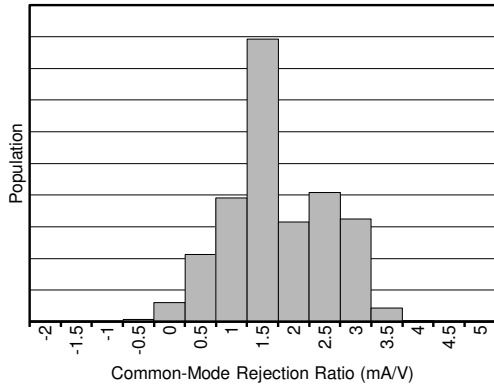

Figure 6-7. INA250A2 Common-Mode Rejection Ratio Distribution

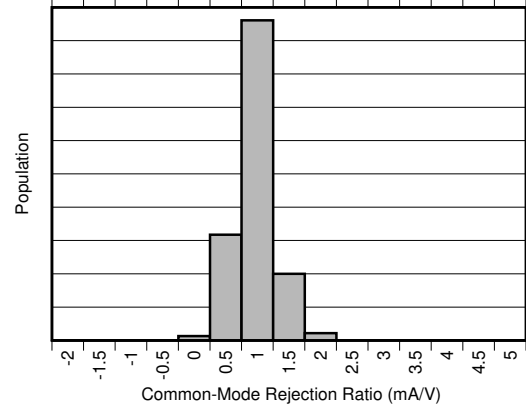

Figure 6-8. INA250A3 Common-Mode Rejection Ratio Distribution

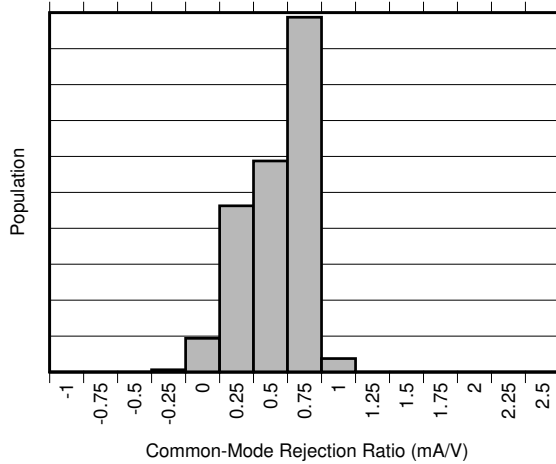

Figure 6-9. INA250A4 Common-Mode Rejection Ratio Distribution

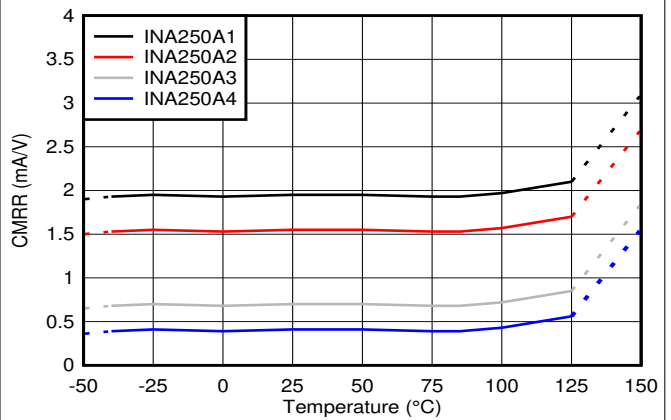

Figure 6-10. Common-Mode Rejection Ratio vs Temperature

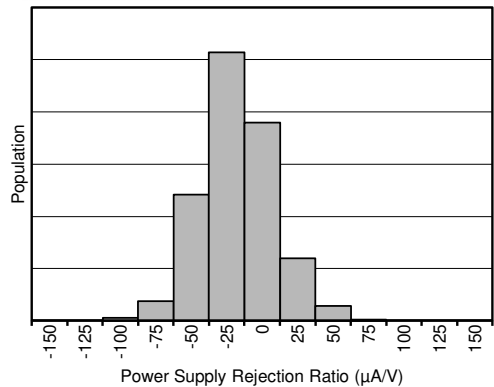

Figure 6-11. Power-Supply Rejection Ratio Distribution

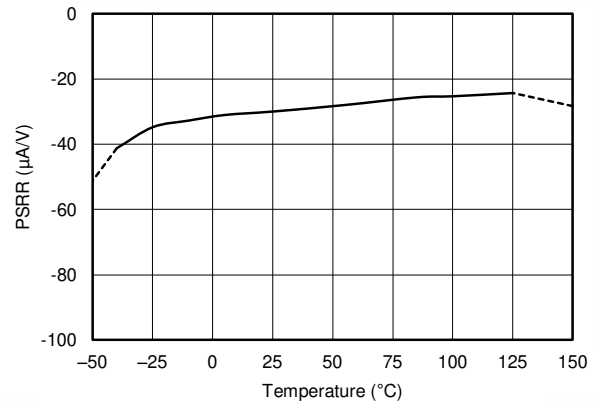

Figure 6-12. Power-Supply Rejection Ratio vs Temperature

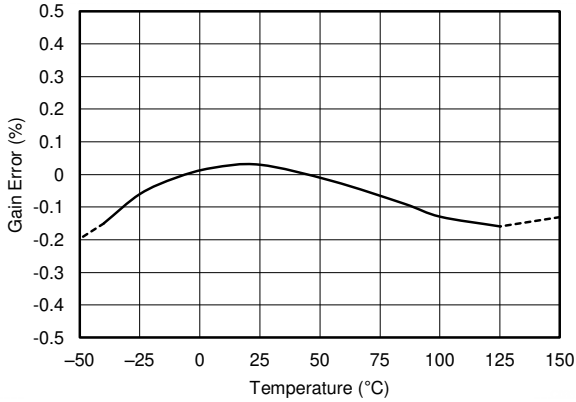
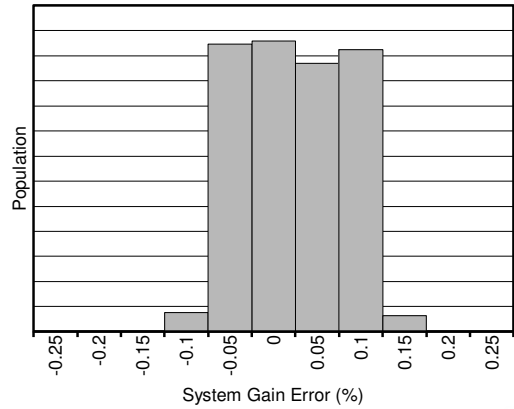

Figure 6-13. System Gain Error vs Temperature



System gain error = R_{SHUNT} error + amplifier gain error, load current = 10 A

Figure 6-14. System Gain Error Distribution

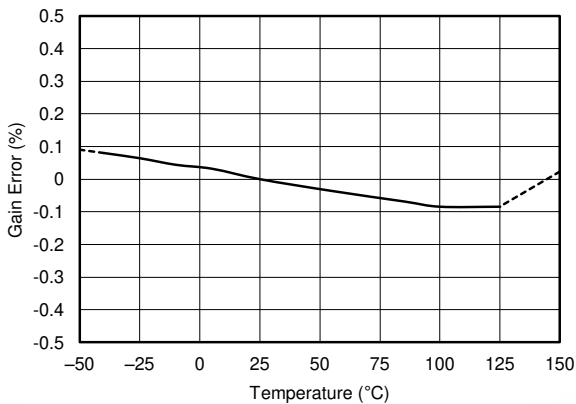
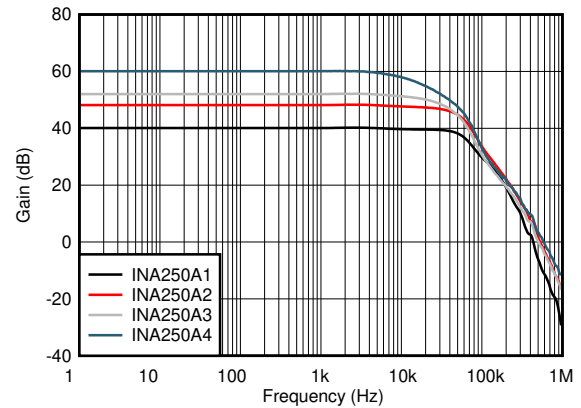
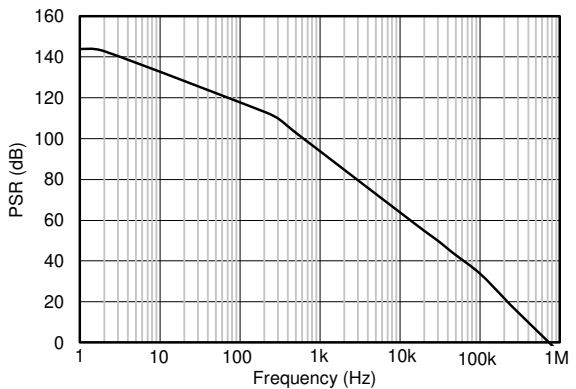

Figure 6-15. Amplifier Gain Error vs Temperature



$V_{CM} = 12\text{ V}$, $I_{SENSE} = 500\text{ mA}_{APP}$

Figure 6-16. Amplifier Gain vs Frequency



$V_{CM} = 12\text{ V}$, $V_{REF} = 2.5\text{ V}$, $I_{SENSE} = 0\text{ A}$, $V_S = 5\text{ V} + 250\text{-mV}$ sine disturbance

Figure 6-17. Power-Supply Rejection vs Frequency

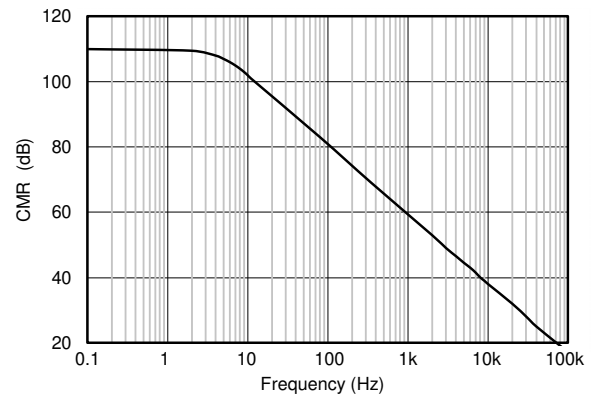

$V_S = 5\text{ V}$, $V_{REF} = 2.5\text{ V}$, $I_{SENSE} = 0\text{ A}$, $V_{CM} = 1\text{-V}$ sine wave

Figure 6-18. Common-Mode Rejection vs Frequency

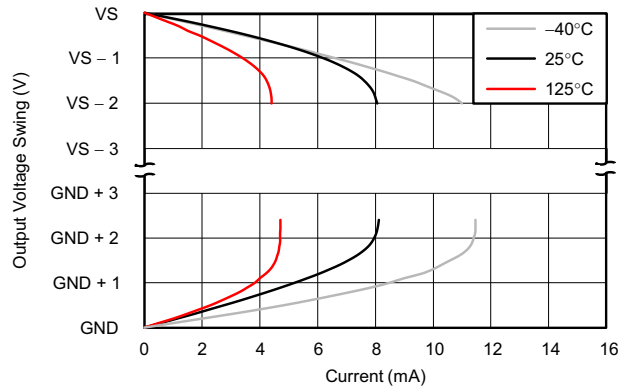

Figure 6-19. Output Voltage Swing vs Output Current

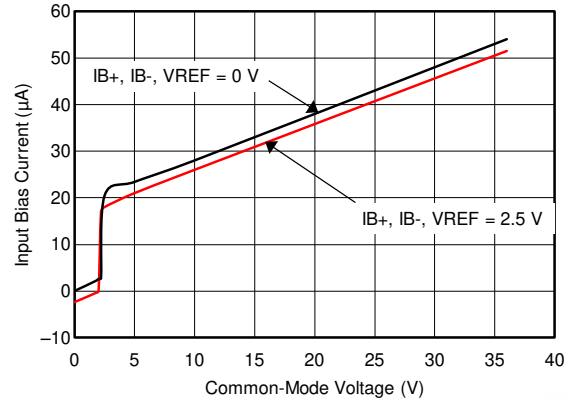

Figure 6-20. Input Bias Current vs Common-Mode Voltage (VS = 5 V)

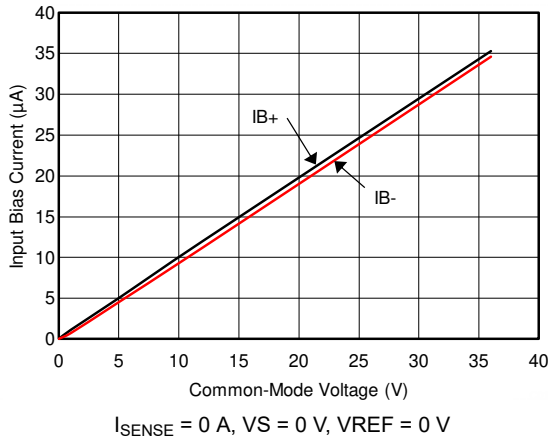

Figure 6-21. Input Bias Current vs Common-Mode Voltage (VS = 0 V)

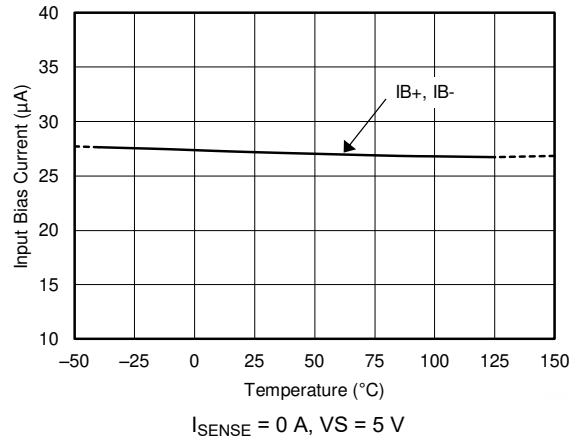

Figure 6-22. Input Bias Current vs Temperature

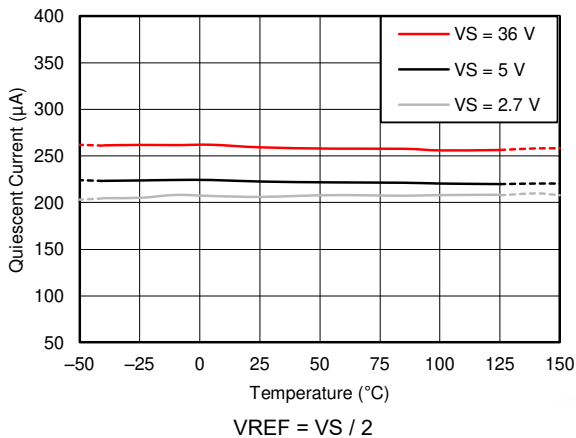

Figure 6-23. Quiescent Current vs Temperature

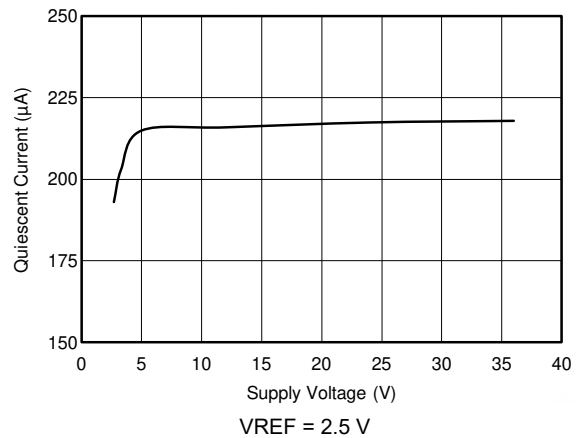
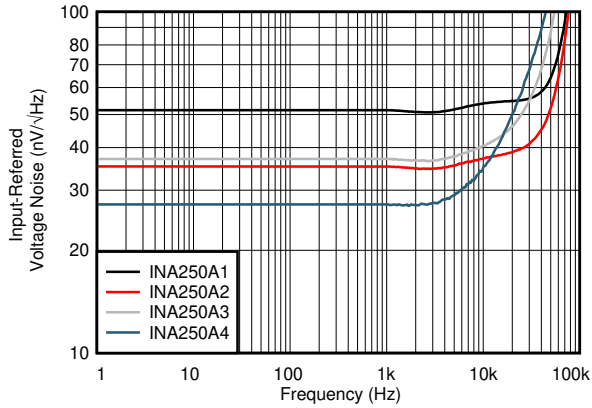
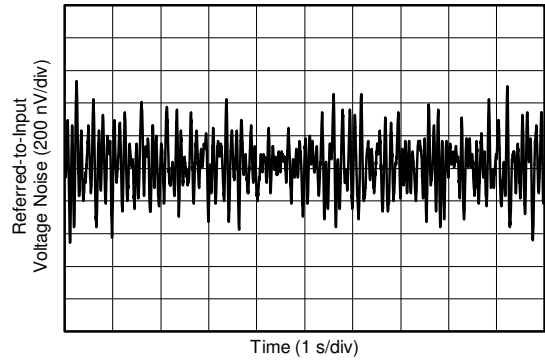

Figure 6-24. Quiescent Current vs Supply Voltage



$V_S = 5\text{ V}$, $V_{REF} = 2.5\text{ V}$, $I_{SENSE} = 0\text{ A}$

Figure 6-25. Input-Referred Voltage Noise vs Frequency



$V_S = 5\text{ V}$, $V_{CM} = 0\text{ V}$, $I_{SENSE} = 0\text{ A}$

Figure 6-26. 0.1-Hz to 10-Hz Voltage Noise (Referred-to-Input)

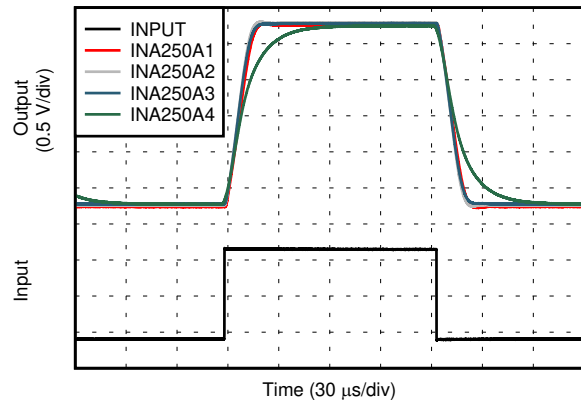

Input = $(V_{IN+}) - (V_{IN-})$

Figure 6-27. Step Response

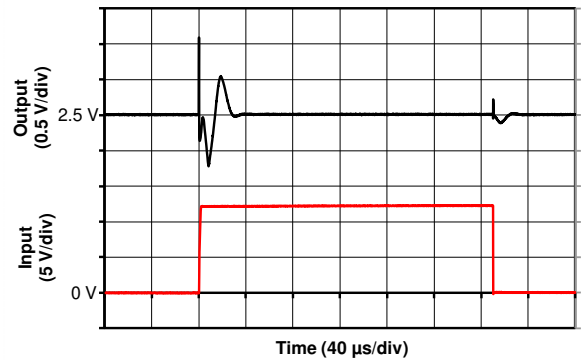

Input = V_{IN+} , $V_{REF} = 2.5\text{ V}$

Figure 6-28. Common-Mode Transient Response

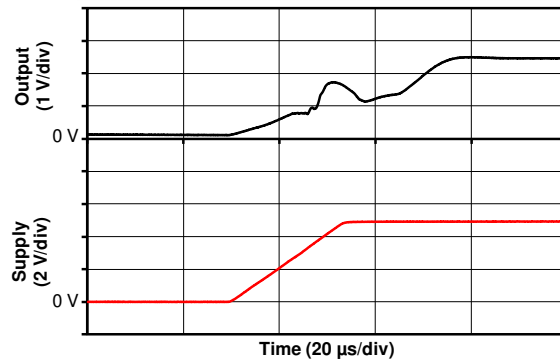

Figure 6-29. Start-Up Response

7 Detailed Description

7.1 Overview

The INA250 features a 2-m Ω , precision, current-sensing resistor and a 36-V common-mode, zero-drift topology, precision, current-sensing amplifier integrated into a single package. High precision measurements are enabled through the matching of the shunt resistor value and the current-sensing amplifier gain providing a highly-accurate, system-calibrated solution. Multiple gain versions are available to allow for the optimization of the desired full-scale output voltage based on the target current range expected in the application.

7.2 Functional Block Diagram

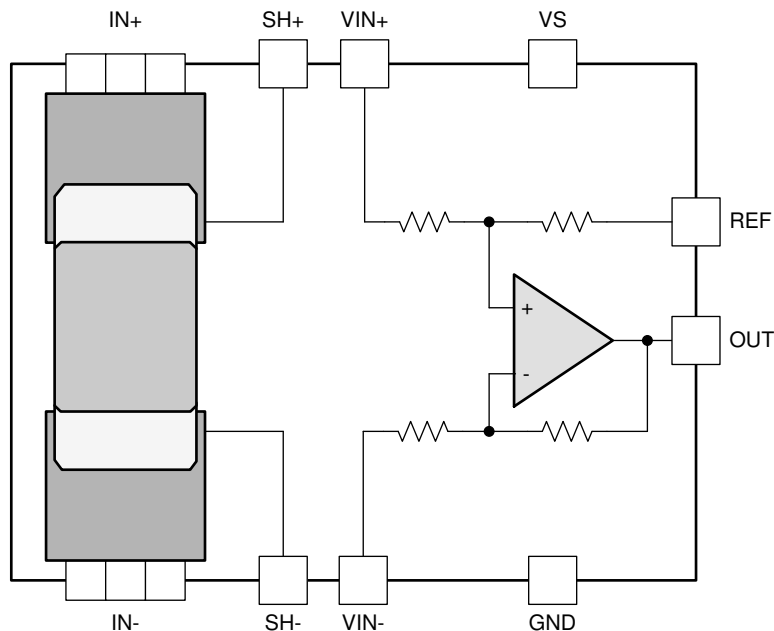

7.3 Feature Description

7.3.1 Integrated Shunt Resistor

The INA250 features a precise, low-drift, current-sensing resistor to allow for precision measurements over the entire specified temperature range of -40°C to 125°C . The integrated current-sensing resistor ensures measurement stability over temperature as well as improving layout and board constraint difficulties common in high precision measurements.

The onboard current-sensing resistor is designed as a 4-wire (or Kelvin) connected resistor that enables accurate measurements through a force-sense connection. Connecting the amplifier inputs pins (VIN $-$ and VIN $+$) to the sense pins of the shunt resistor (SH $-$ and SH $+$) eliminates many of the parasitic impedances commonly found in typical very-low sensing-resistor level measurements. Although the sense connection of the current-sensing resistor can be accessed via the SH $+$ and SH $-$ pins, this resistor is not intended to be used as a stand-alone component. The INA250 is system-calibrated to ensure that the current-sensing resistor and current-sensing amplifier are both precisely matched to one another. Use of the shunt resistor without the onboard amplifier results in a current-sensing resistor tolerance of approximately 5%. To achieve the optimized system gain specification, the onboard sensing resistor must be used with the internal current-sensing amplifier.

The INA250 has approximately 4.5 m Ω of package resistance. 2 m Ω of this total package resistance is a precisely-controlled resistance from the Kelvin-connected current-sensing resistor used by the amplifier. The power dissipation requirements of the system and package are based on the total 4.5-m Ω package resistance between the IN $+$ and IN $-$ pins. The heat dissipated across the package when current flows through the device ultimately determines the maximum current that can be safely handled by the package. The current consumption of the silicon is relatively low, leaving the total package resistance carrying the high load current as the primary contributor to the total power dissipation of the package. The maximum safe-operating current level is set to

ensure that the heat dissipated across the package is limited so that no damage to the resistor or the package itself occurs or that the internal junction temperature of the silicon does not exceed a 150°C limit.

External factors (such as ambient temperature, external air flow, and PCB layout) can contribute to how effectively the heat developed as a result of the current flowing through the total package resistance can be removed from within the device. Under the conditions of no air flow, a maximum ambient temperature of 85°C, and 1-oz. copper input power planes, the INA250 can accommodate continuous current levels up to 15 A. As shown in Figure 7-1, the current handling capability is derated at temperatures above the 85°C level with safe operation up to 10 A at a 125°C ambient temperature. With air flow and larger 2-oz. copper input power planes, the INA250 can safely accommodate continuous current levels up to 15 A over the entire –40°C to 125°C temperature range.

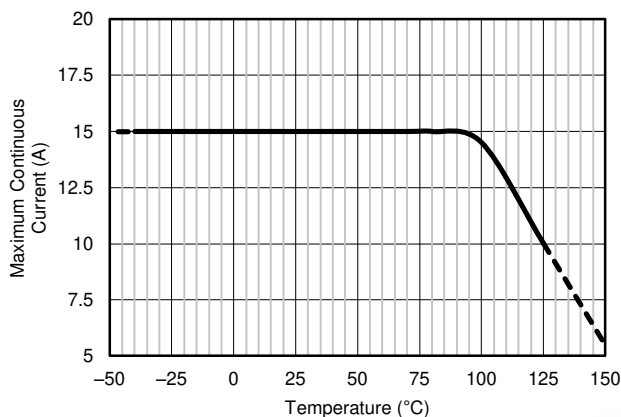

Figure 7-1. Maximum Current vs Temperature

7.3.2 Short-Circuit Duration

The INA250 features a physical shunt resistance that is able to withstand current levels higher than the continuous handling limit of 15 A without sustaining damage to the current-sensing resistor or the current-sensing amplifier if the excursions are very brief. Figure 7-2 shows the short-circuit duration curve for the INA250.

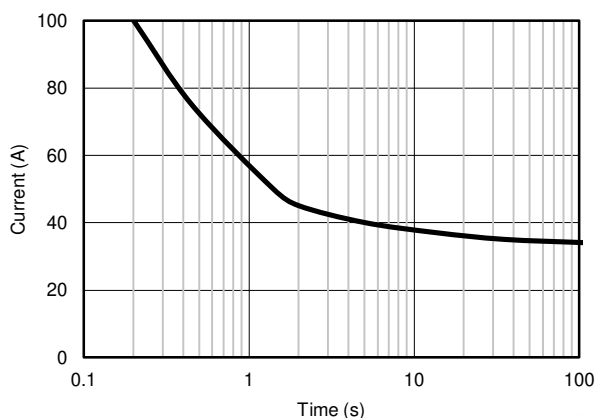

Figure 7-2. Short-Circuit Duration

7.3.3 Temperature Stability

System calibration is common for many industrial applications to eliminate initial component and system-level errors that can be present. A system-level calibration can reduce the initial accuracy requirement for many of the individual components because the errors associated with these components are effectively eliminated through the calibration procedure. Performing this calibration can enable precision measurements at the temperature in which the system is calibrated, but as the system temperature changes as a result of external ambient changes or due to self heating, measurement errors are reintroduced. Without accurate temperature

compensation used in addition to the initial adjustment, the calibration procedure is not effective in accounting for these temperature-induced changes. One of the primary benefits of the very low temperature coefficient of the INA250 (including both the integrated current-sensing resistor and current-sensing amplifier) is ensuring that the device measurement remains highly accurate, even when the temperature changes throughout the specified temperature range of the device.

For the integrated current-sensing resistor, the drift performance is shown in [Figure 7-3](#). Although several temperature ranges are specified in the *Electrical Characteristics* table, applications operating in ranges other than those described can use [Figure 7-3](#) to determine how much variance in the shunt resistor value can be expected. As with any resistive element, the tolerance of the component varies when exposed to different temperature conditions. For the current-sensing resistor integrated in the INA250, the resistor does vary slightly more when operated in temperatures ranging from -40°C to 0°C than when operated from 0°C to 125°C . However, even in the -40°C to 0°C temperature range, the drift is still quite low at 25 ppm/ $^{\circ}\text{C}$.

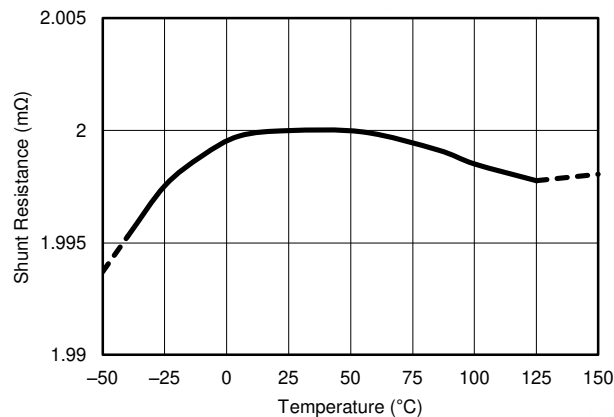

Figure 7-3. Sensing Resistor vs Temperature

An additional aspect to consider is that when current flows through the current-sensing resistor, power is dissipated across this component. This dissipated power results in an increase in the internal temperature of the package, including the integrated sensing resistor. This resistor self-heating effect results in an increase of the resistor temperature helping to move the component out of the colder, wider drift temperature region.

7.4 Device Functional Modes

7.4.1 Amplifier Operation

The INA250 current-sense amplifier can be configured to measure both unidirectional and bidirectional currents through the reference voltage level applied to the reference pin, REF. The reference voltage connected to REF sets the output level that corresponds with a zero input current condition. For unidirectional operation, tie the REF pin to ground so that when the current increases, the output signal also increases upwards from this reference voltage (or ground in this case). For bidirectional currents, an external voltage source can be used as the reference voltage connected to the REF pin to bias up the output. Set the reference voltage to enable sufficient range above and below this level based on the expected current range to be measured. Positive currents result in an output signal that increases from the zero-current output level set by the reference voltage whereas negative currents result in an output signal that decreases.

For both unidirectional and bidirectional applications, the amplifier transfer function is shown in [Equation 1](#):

$$V_{OUT} = (I_{LOAD} \times GAIN) + V_{REF} \quad (1)$$

where:

- I_{LOAD} is the current being measured passing through the internal shunt resistor,
- GAIN is the corresponding gain (mA/V) of the selected device, and
- V_{REF} is the voltage applied to the REF pin

As with any difference amplifier, the INA250 common-mode rejection ratio is affected by any impedance present at the REF input. This concern is not a problem when the REF pin is connected directly to a reference or power supply. When using resistive dividers from a power supply or a reference voltage, buffer the REF pin with an op amp.

7.4.2 Input Filtering

An obvious and straightforward location for filtering is at the device output; however, this location negates the advantage of the low output impedance of the output stage buffer. The input then represents the best location for implementing external filtering. [Figure 7-4](#) shows the typical implementation of the input filter for the device.

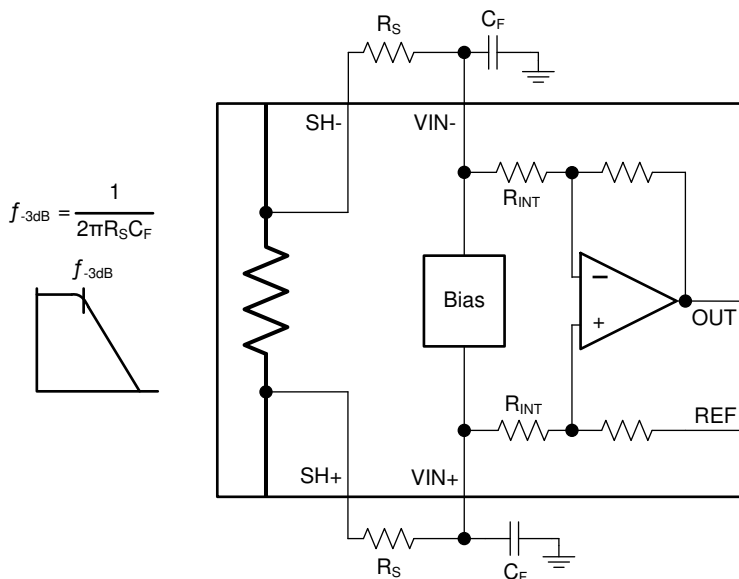

Figure 7-4. Input Filter

The addition of external series resistance at the input pins to the amplifier, however, creates an additional error in the measurement. Keep the value of these series resistors to 10 Ω or less, if possible, to reduce the affect to accuracy. The internal bias network illustrated in Figure 7-4 present at the input pins creates a mismatch in input bias currents when a differential voltage is applied between the input pins, as shown in Figure 7-5.

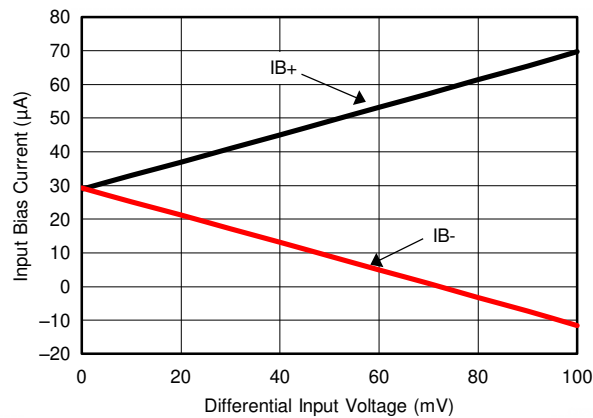

Figure 7-5. Input Bias Current vs Differential Input Voltage

7.4.2.1 Calculating Gain Error Resulting from External Filter Resistance

If additional external series filter resistors are added to the circuit, the mismatch in bias currents results in a mismatch of voltage drops across the filter resistors. This mismatch creates a differential error voltage that subtracts from the voltage developed across the Kelvin connection of the shunt resistor, thus reducing the voltage that reaches the amplifier input terminals. Without the additional series resistance, the mismatch in input bias currents has little effect on device operation as a result of the low input bias current of the amplifier and the typically low impedance of the traces between the shunt and amplifier input pins. The amount of error these external filter resistors add to the measurement can be calculated using Equation 3, where the gain error factor is calculated using Equation 2.

The amount of variance between the differential voltage present at the device input relative to the voltage developed at the shunt resistor is based both on the external series resistance value as well as the internal input resistors, R_{INT} ; see Figure 7-4. The reduction of the shunt voltage reaching the device input pins appears as a gain error when comparing the output voltage relative to the voltage across the shunt resistor. A factor can be calculated to determine the amount of gain error that is introduced by the addition of external series resistance. Equation 2 calculates the expected deviation from the shunt voltage compared to the expected voltage at the device input pins.

$$\text{Gain Error Factor} = \frac{(1250 \times R_{INT})}{(1250 \times R_S) + (1250 \times R_{INT}) + (R_S \times R_{INT})} \quad (2)$$

where:

- R_{INT} is the internal input resistor and
- R_S is the external series resistance

$$\text{Gain Error (\%)} = 100 - (100 \times \text{Gain Error Factor}) \quad (3)$$

With the adjustment factor equation including the device internal input resistance, this factor varies with each gain version; see Table 7-1. Each individual device gain error factor is listed in Table 7-2.

The gain error that can be expected from the addition of the external series resistors can then be calculated based on Equation 3.

Table 7-1. Input Resistance

DEVICE	GAIN	R _{INT}
INA250A1	200 mV/A	50 kΩ
INA250A2	500 mV/A	20 kΩ
INA250A3	800 mV/A	12.5 kΩ
INA250A4	2 V/A	5 kΩ

Table 7-2. Device Gain Error Factor

DEVICE	SIMPLIFIED GAIN ERROR FACTOR
INA250A1	$\frac{50,000}{(41 \cdot R_S) + 50,000}$
INA250A2	$\frac{20,000}{(17 \cdot R_S) + 20,000}$
INA250A3	$\frac{12,500}{(11 \cdot R_S) + 12,500}$
INA250A4	$\frac{1,000}{R_S + 1,000}$

For example, using an INA250A2 and the corresponding gain error equation from [Table 7-2](#), a series resistance of 10 Ω results in a gain error factor of 0.991. The corresponding gain error is then calculated using [Equation 3](#), resulting in a gain error of approximately 0.84% because of the external 10-Ω series resistors.

7.4.3 Shutting Down the Device

Although the device does not have a shutdown pin, the low power consumption allows for the device to be powered from the output of a logic gate or transistor switch that can turn on and turn off the voltage connected to the device power-supply pin. However, in current-shunt monitoring applications, there is also a concern for how much current is drained from the shunt circuit in shutdown conditions. Evaluating this current drain involves considering the device simplified schematic in shutdown mode, as shown in [Figure 7-6](#).

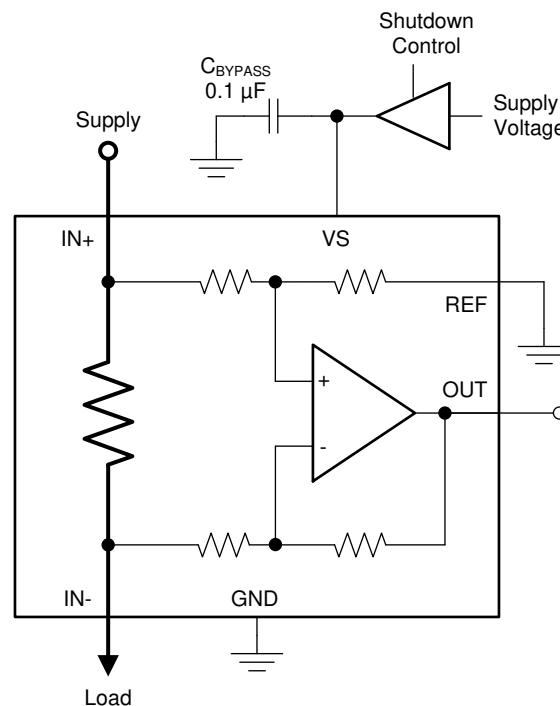

Figure 7-6. Shutting Down the Device

Note that there is typically an approximate 1-M Ω impedance (from the combination of the feedback and input resistors) from each device input to the REF pin. The amount of current flowing through these pins depends on the respective configuration. For example, if the REF pin is grounded, calculating the effect of the 1-M Ω impedance from the shunt to ground is straightforward. However, if the reference or op amp is powered when the device is shut down, the calculation is direct. Instead of assuming 1 M Ω to ground, assume 1 M Ω to the reference voltage. If the reference or op amp is also shut down, some knowledge of the reference or op amp output impedance under shutdown conditions is required. For instance, if the reference source functions similar to an open circuit when un-powered, little or no current flows through the 1-M Ω path.

7.4.4 Using the Device with Common-Mode Transients Above 36 V

With a small amount of additional circuitry, the device can be used in circuits subject to transients higher than 36 V (such as in automotive applications). Use only zener diodes or zener-type transient absorbers (sometimes referred to as *transzorbs*); any other type of transient absorber has an unacceptable time delay. Start by adding a pair of resistors, as shown in Figure 7-7, as a working impedance for the zener. Keeping these resistors as small as possible is preferable, most often approximately 10 Ω . This value limits the affect on accuracy with the addition of these external components, as described in the *Input Filtering* section. Device interconnections between the shunt resistor and amplifier have a current handling limit of 1 A. Using a 10- Ω resistor limits the allowable transient range to 10 V above the zener clamp in order to not damage the device. Larger resistor values can be used in this protection circuit to accommodate a larger transient voltage range, resulting in a larger affect on gain error. Because this circuit limits only short-term transients, many applications are satisfied with a 10- Ω resistor along with conventional zener diodes of the lowest power rating available.

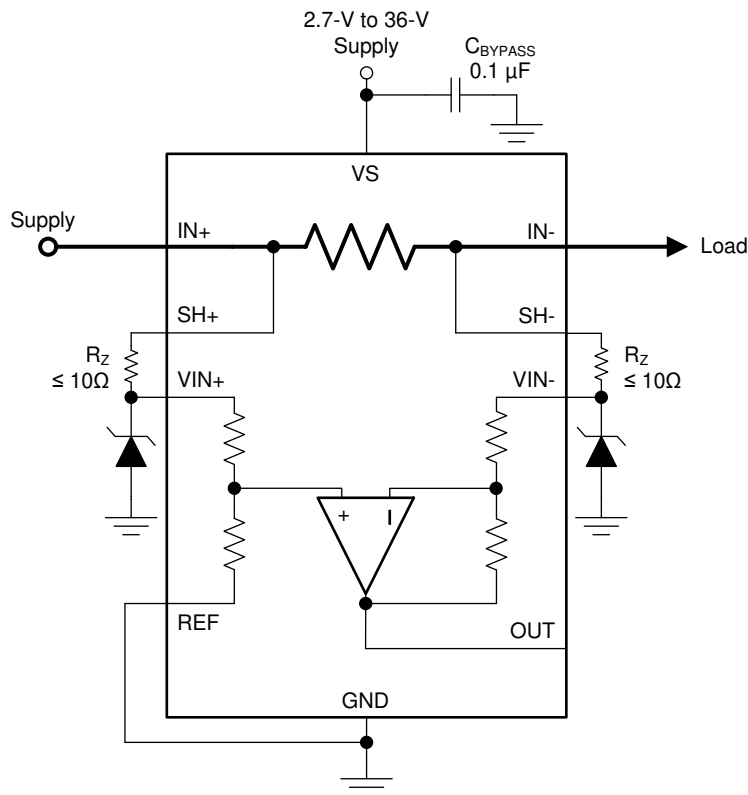

Figure 7-7. Device Transient Protection

8 Applications and Implementation

Note

Information in the following applications sections is not part of the TI component specification, and TI does not warrant its accuracy or completeness. TI's customers are responsible for determining suitability of components for their purposes, as well as validating and testing their design implementation to confirm system functionality.

8.1 Application Information

The INA250 measures the voltage developed across the internal current-sensing resistor when current passes through it. The ability to drive the reference pin to adjust the functionality of the output signal offers multiple configurations, as discussed in this section.

8.2 Typical Applications

8.2.1 Current Summing

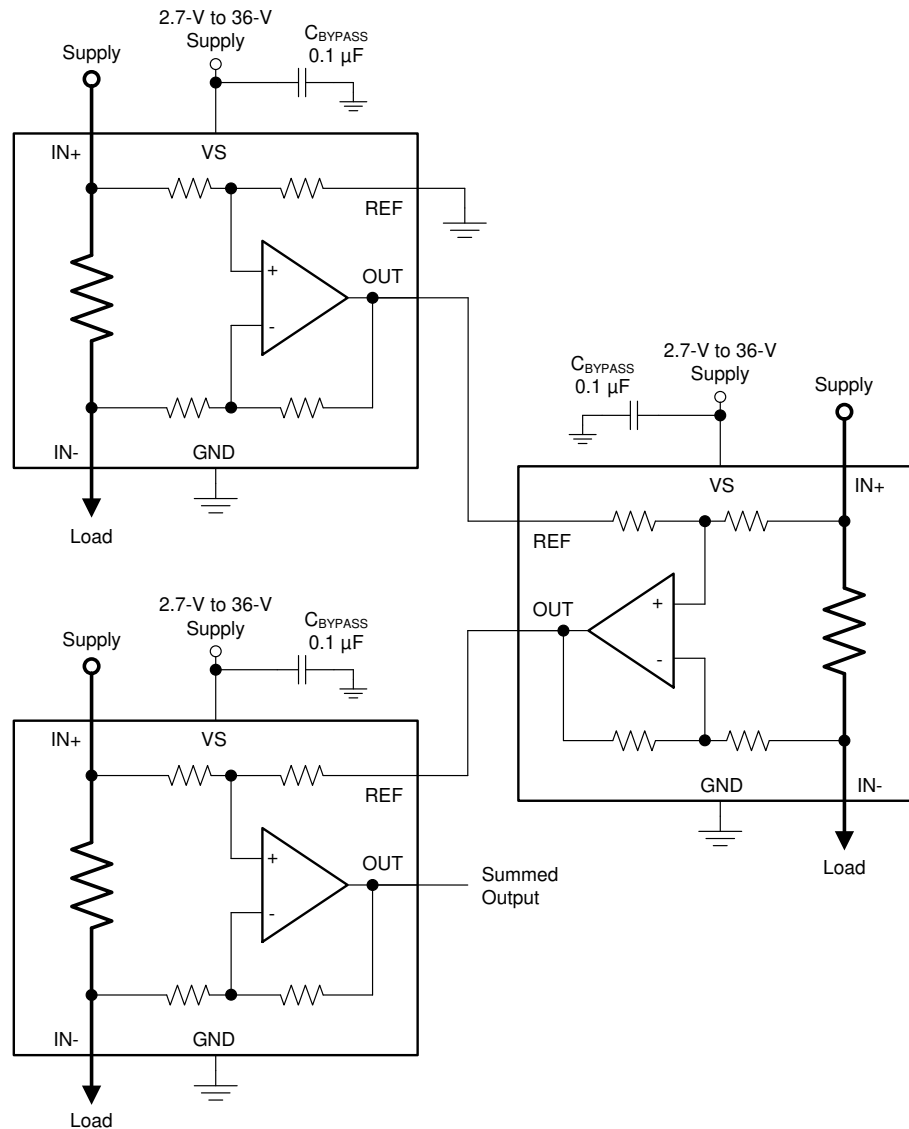

Figure 8-1. Daisy-Chain Configuration

8.2.1.1 Design Requirements

Three daisy-chained devices are illustrated in Figure 8-1. The reference input of the first INA250 sets the quiescent level on the output of all the INA250 devices in the string.

8.2.1.2 Detailed Design Procedure

The outputs of multiple INA250 devices are easily summed by connecting the output signal of one INA250 to the reference input of a second INA250. Summing beyond two devices is possible by repeating this configuration, connecting the output signal of the next INA250 to the reference pin of a subsequent INA250 in the chain. The output signal of the final INA250 in this chain includes the current level information for all channels in the chain.

8.2.1.3 Application Curve

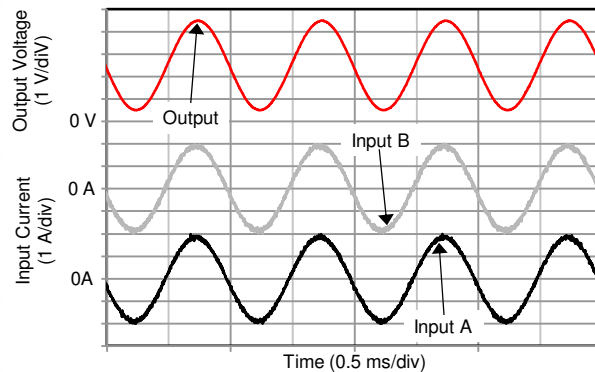

$$V_S = 5 \text{ V}, V_{REF} = 2.5 \text{ V}$$

Figure 8-2. Daisy-Chain Configuration Output Response

8.2.2 Parallel Multiple INA250 Devices for Higher Current

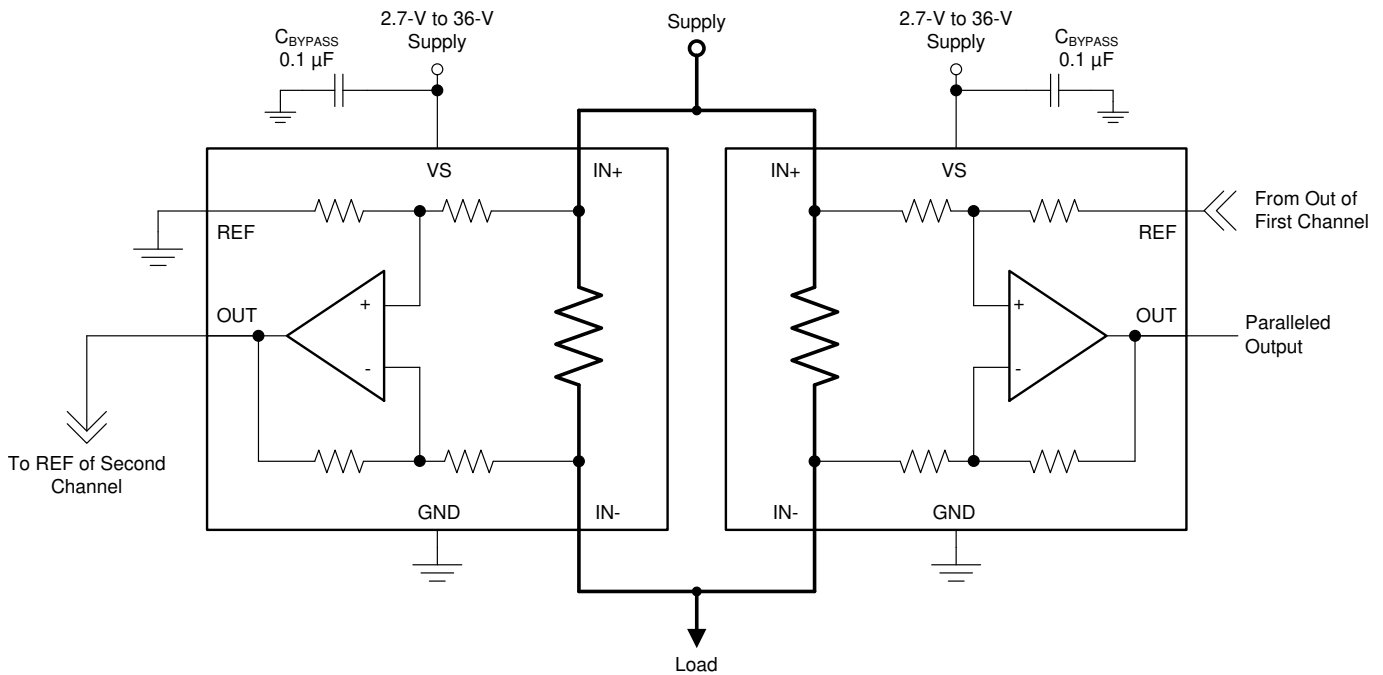

Figure 8-3. Parallel Summing Configuration

8.2.2.1 Design Requirements

The parallel connection for multiple INA250 devices can be used to reduce the equivalent overall sense resistance, enabling monitoring of higher current levels than a single device is able to accommodate alone. This configuration also uses a summing arrangement, as described in the [Current Summing](#) section. A parallel summing configuration is shown in [Figure 8-3](#).

8.2.2.2 Detailed Design Procedure

With a summing configuration the output of the first channel is fed into the reference input of the second, adding the distributed measurements back together into a single measured value.

8.2.2.3 Application Curve

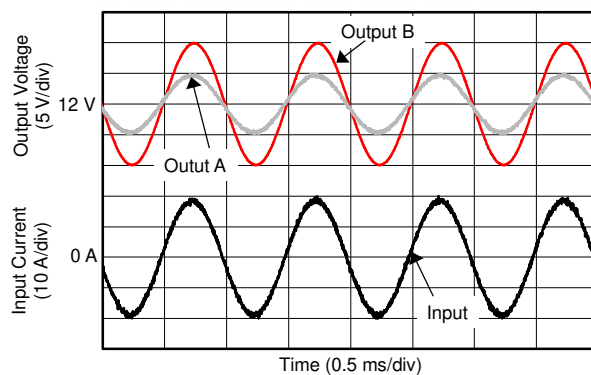

$$V_S = 24 \text{ V}, V_{REF} = 12 \text{ V}$$

Figure 8-4. Parallel Configuration Output Response

8.2.3 Current Differencing

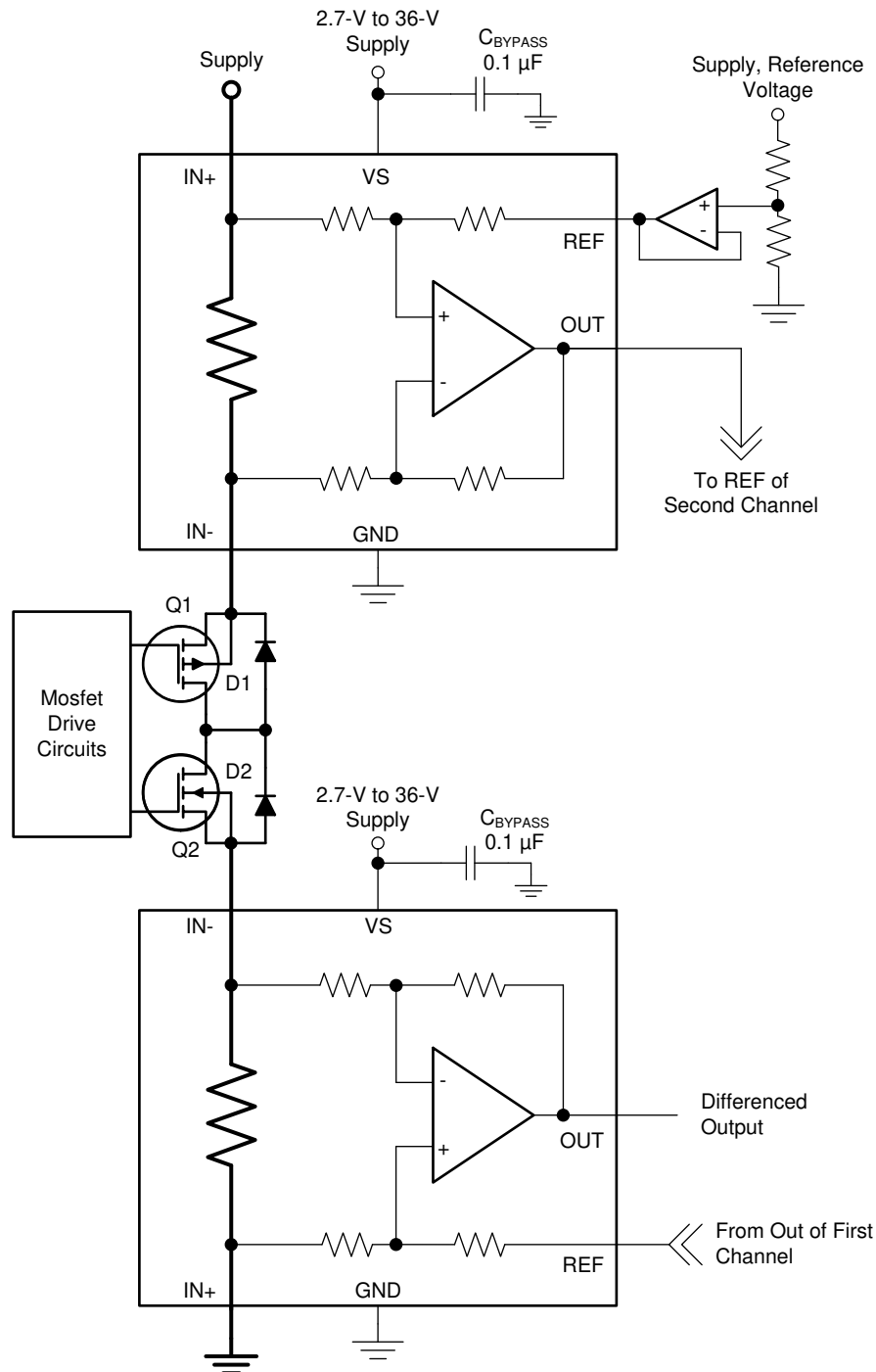

Figure 8-5. Current Differencing Configuration

8.2.3.1 Design Requirements

Occasionally, the need may arise to confirm that the current into a load is identical to the current coming out of a load, such as when performing diagnostic testing or fault detection. This procedure requires precision current differencing. This method is the same as current summing, except that the two amplifiers have the respective inputs connected opposite of each other. Under normal operating conditions, the final output is very close to the reference value and proportional to any current difference. [Figure 8-5](#) is an example of two INA250 devices connected for current differencing.

8.2.3.2 Detailed Design Procedure

The load current can also be measured directly at the output of the first channel. Although technically this configuration is current differencing, this connection (see [Figure 8-5](#)) is really intended to allow the upper (positive) sense channel to report any positive-going excursions in the overall output and the lower (negative) sense channel to report any negative-going excursions.

8.2.3.3 Application Curve

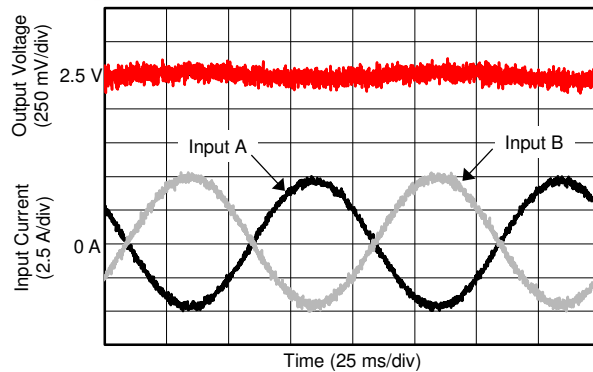

$$V_S = 5 \text{ V}, V_{REF} = 2.5 \text{ V}$$

Figure 8-6. Current Differencing Configuration Output Response

8.3 Power Supply Recommendations

The input circuitry of the device can accurately measure signals on common-mode voltages beyond the power-supply voltage, V_S . For example, the voltage applied to the V_S power-supply pin can be 5 V, whereas the load power-supply voltage being monitored (the common-mode voltage) can be as high as 36 V. Note also that the device can withstand the full 0-V to 36-V range at the input pins, regardless of whether the device has power applied or not. Power-supply bypass capacitors are required for stability and must be placed as closely as possible to the supply and ground pins of the device. A typical value for this supply bypass capacitor is 0.1 μF . Applications with noisy or high-impedance power supplies can require additional decoupling capacitors to reject power-supply noise.

8.4 Layout

8.4.1 Layout Guidelines

- The INA250 is specified for current handling of up to 10 A over the entire -40°C to 125°C temperature range using a 1-oz. copper pour for the input power plane as well as no external airflow passing over the device.
- The primary current-handling limitation for the INA250 is how much heat is dissipated inside the package. Efforts to improve heat transfer out of the package and into the surrounding environment improve the ability of the device to handle currents of up to 15 A over the entire -40°C to 125°C temperature range.
- Heat transfer improvements primarily involve larger copper power traces and planes with increased copper thickness (2 oz.) as well as providing airflow to pass over the device. The [INA250EVM](#) features a 2-oz. copper pour for the planes and is capable of supporting 15 A at temperatures up to 125°C .
- Place the power-supply bypass capacitor as close as possible to the supply and ground pins. The recommended value of this bypass capacitor is 0.1 μF . Additional decoupling capacitance can be added to compensate for noisy or high-impedance power supplies.

8.4.2 Layout Examples

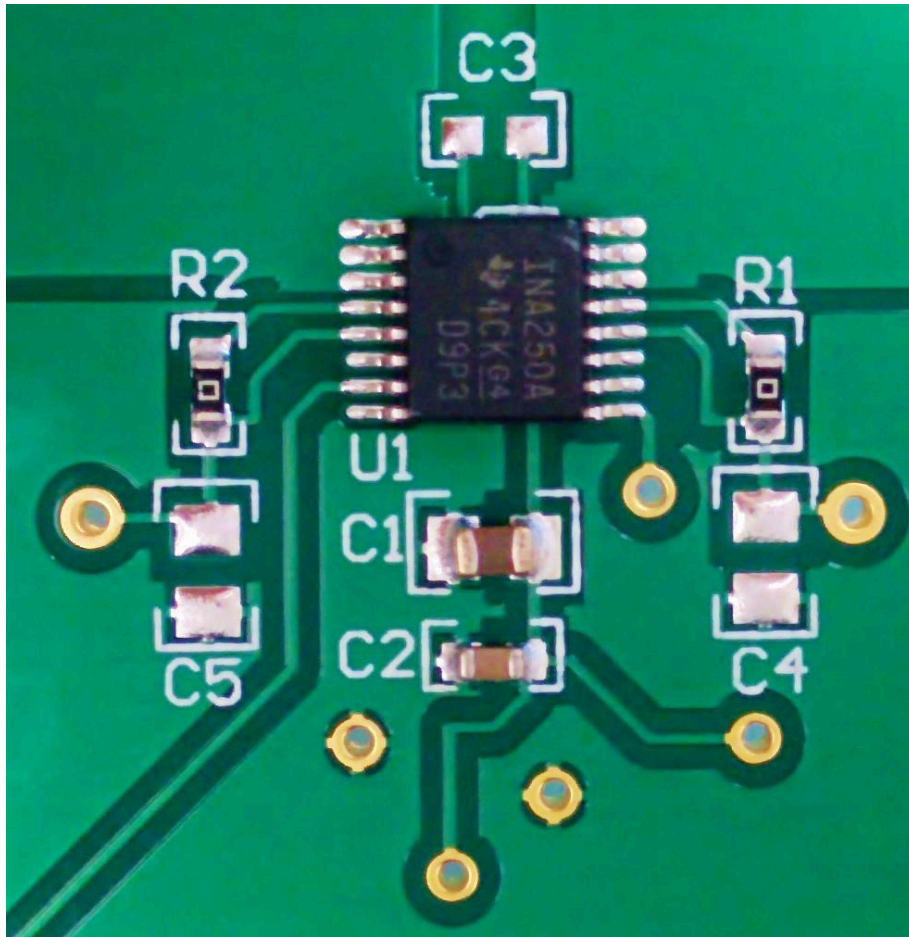

Figure 8-7. Recommended Layout

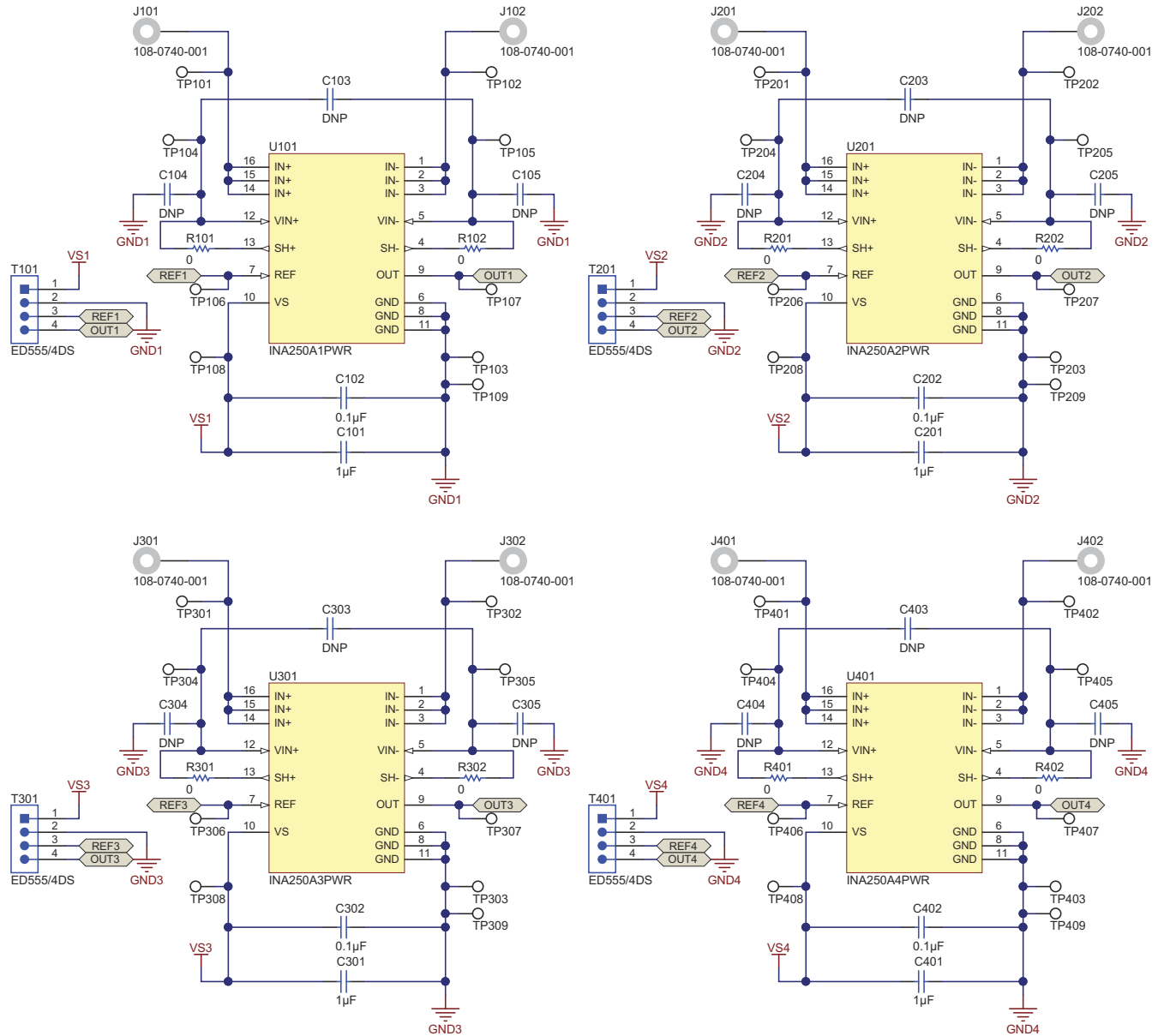

Figure 8-8. Recommended Layout Schematic

9 Device and Documentation Support

9.1 Documentation Support

9.1.1 Related Documentation

- INA250EVM User Guide, [SBOU153](#)

9.2 Receiving Notification of Documentation Updates

To receive notification of documentation updates, navigate to the device product folder on [ti.com](#). Click on *Subscribe to updates* to register and receive a weekly digest of any product information that has changed. For change details, review the revision history included in any revised document.

9.3 Support Resources

[TI E2E™ support forums](#) are an engineer's go-to source for fast, verified answers and design help — straight from the experts. Search existing answers or ask your own question to get the quick design help you need.

Linked content is provided "AS IS" by the respective contributors. They do not constitute TI specifications and do not necessarily reflect TI's views; see TI's [Terms of Use](#).

9.4 Trademarks

TI E2E™ is a trademark of Texas Instruments.

All trademarks are the property of their respective owners.

9.5 Electrostatic Discharge Caution



This integrated circuit can be damaged by ESD. Texas Instruments recommends that all integrated circuits be handled with appropriate precautions. Failure to observe proper handling and installation procedures can cause damage.

ESD damage can range from subtle performance degradation to complete device failure. Precision integrated circuits may be more susceptible to damage because very small parametric changes could cause the device not to meet its published specifications.

9.6 Glossary

[TI Glossary](#) This glossary lists and explains terms, acronyms, and definitions.

10 Mechanical, Packaging, and Orderable Information

The following pages include mechanical, packaging, and orderable information. This information is the most current data available for the designated devices. This data is subject to change without notice and revision of this document. For browser-based versions of this data sheet, refer to the left-hand navigation.

PACKAGING INFORMATION

Orderable Device	Status (1)	Package Type	Package Drawing	Pins	Package Qty	Eco Plan (2)	Lead finish/ Ball material (6)	MSL Peak Temp (3)	Op Temp (°C)	Device Marking (4/5)	Samples
INA250A1PW	ACTIVE	TSSOP	PW	16	90	RoHS & Green	NIPDAU	Level-2-260C-1 YEAR	-40 to 125	I250A1	Samples
INA250A1PWR	ACTIVE	TSSOP	PW	16	2000	RoHS & Green	NIPDAU	Level-2-260C-1 YEAR	-40 to 125	I250A1	Samples
INA250A2PW	ACTIVE	TSSOP	PW	16	90	RoHS & Green	NIPDAU	Level-2-260C-1 YEAR	-40 to 125	I250A2	Samples
INA250A2PWR	ACTIVE	TSSOP	PW	16	2000	RoHS & Green	NIPDAU	Level-2-260C-1 YEAR	-40 to 125	I250A2	Samples
INA250A3PW	NRND	TSSOP	PW	16	90	RoHS & Green	NIPDAU	Level-2-260C-1 YEAR	-40 to 125	I250A3	
INA250A3PWR	ACTIVE	TSSOP	PW	16	2000	RoHS & Green	NIPDAU	Level-2-260C-1 YEAR	-40 to 125	I250A3	Samples
INA250A4PW	ACTIVE	TSSOP	PW	16	90	RoHS & Green	NIPDAU	Level-2-260C-1 YEAR	-40 to 125	I250A4	Samples
INA250A4PWR	ACTIVE	TSSOP	PW	16	2000	RoHS & Green	NIPDAU	Level-2-260C-1 YEAR	-40 to 125	I250A4	Samples

(1) The marketing status values are defined as follows:

ACTIVE: Product device recommended for new designs.

LIFEBUY: TI has announced that the device will be discontinued, and a lifetime-buy period is in effect.

NRND: Not recommended for new designs. Device is in production to support existing customers, but TI does not recommend using this part in a new design.

PREVIEW: Device has been announced but is not in production. Samples may or may not be available.

OBSELETE: TI has discontinued the production of the device.

(2) **RoHS:** TI defines "RoHS" to mean semiconductor products that are compliant with the current EU RoHS requirements for all 10 RoHS substances, including the requirement that RoHS substance do not exceed 0.1% by weight in homogeneous materials. Where designed to be soldered at high temperatures, "RoHS" products are suitable for use in specified lead-free processes. TI may reference these types of products as "Pb-Free".

RoHS Exempt: TI defines "RoHS Exempt" to mean products that contain lead but are compliant with EU RoHS pursuant to a specific EU RoHS exemption.

Green: TI defines "Green" to mean the content of Chlorine (Cl) and Bromine (Br) based flame retardants meet JS709B low halogen requirements of <=1000ppm threshold. Antimony trioxide based flame retardants must also meet the <=1000ppm threshold requirement.

(3) MSL, Peak Temp. - The Moisture Sensitivity Level rating according to the JEDEC industry standard classifications, and peak solder temperature.

(4) There may be additional marking, which relates to the logo, the lot trace code information, or the environmental category on the device.

(5) Multiple Device Markings will be inside parentheses. Only one Device Marking contained in parentheses and separated by a "-" will appear on a device. If a line is indented then it is a continuation of the previous line and the two combined represent the entire Device Marking for that device.

⁽⁶⁾ Lead finish/Ball material - Orderable Devices may have multiple material finish options. Finish options are separated by a vertical ruled line. Lead finish/Ball material values may wrap to two lines if the finish value exceeds the maximum column width.

Important Information and Disclaimer:The information provided on this page represents TI's knowledge and belief as of the date that it is provided. TI bases its knowledge and belief on information provided by third parties, and makes no representation or warranty as to the accuracy of such information. Efforts are underway to better integrate information from third parties. TI has taken and continues to take reasonable steps to provide representative and accurate information but may not have conducted destructive testing or chemical analysis on incoming materials and chemicals. TI and TI suppliers consider certain information to be proprietary, and thus CAS numbers and other limited information may not be available for release.

In no event shall TI's liability arising out of such information exceed the total purchase price of the TI part(s) at issue in this document sold by TI to Customer on an annual basis.

OTHER QUALIFIED VERSIONS OF INA250 :

- Automotive : [INA250-Q1](#)

NOTE: Qualified Version Definitions:

- Automotive - Q100 devices qualified for high-reliability automotive applications targeting zero defects

TAPE AND REEL INFORMATION

QUADRANT ASSIGNMENTS FOR PIN 1 ORIENTATION IN TAPE

*All dimensions are nominal

Device	Package Type	Package Drawing	Pins	SPQ	Reel Diameter (mm)	Reel Width W1 (mm)	A0 (mm)	B0 (mm)	K0 (mm)	P1 (mm)	W (mm)	Pin1 Quadrant
INA250A1PWR	TSSOP	PW	16	2000	330.0	12.4	6.9	5.6	1.6	8.0	12.0	Q1
INA250A2PWR	TSSOP	PW	16	2000	330.0	12.4	6.9	5.6	1.6	8.0	12.0	Q1
INA250A3PWR	TSSOP	PW	16	2000	330.0	12.4	6.9	5.6	1.6	8.0	12.0	Q1
INA250A4PWR	TSSOP	PW	16	2000	330.0	12.4	6.9	5.6	1.6	8.0	12.0	Q1

TAPE AND REEL BOX DIMENSIONS



*All dimensions are nominal

Device	Package Type	Package Drawing	Pins	SPQ	Length (mm)	Width (mm)	Height (mm)
INA250A1PWR	TSSOP	PW	16	2000	356.0	356.0	35.0
INA250A2PWR	TSSOP	PW	16	2000	356.0	356.0	35.0
INA250A3PWR	TSSOP	PW	16	2000	356.0	356.0	35.0
INA250A4PWR	TSSOP	PW	16	2000	356.0	356.0	35.0

TUBE

*All dimensions are nominal

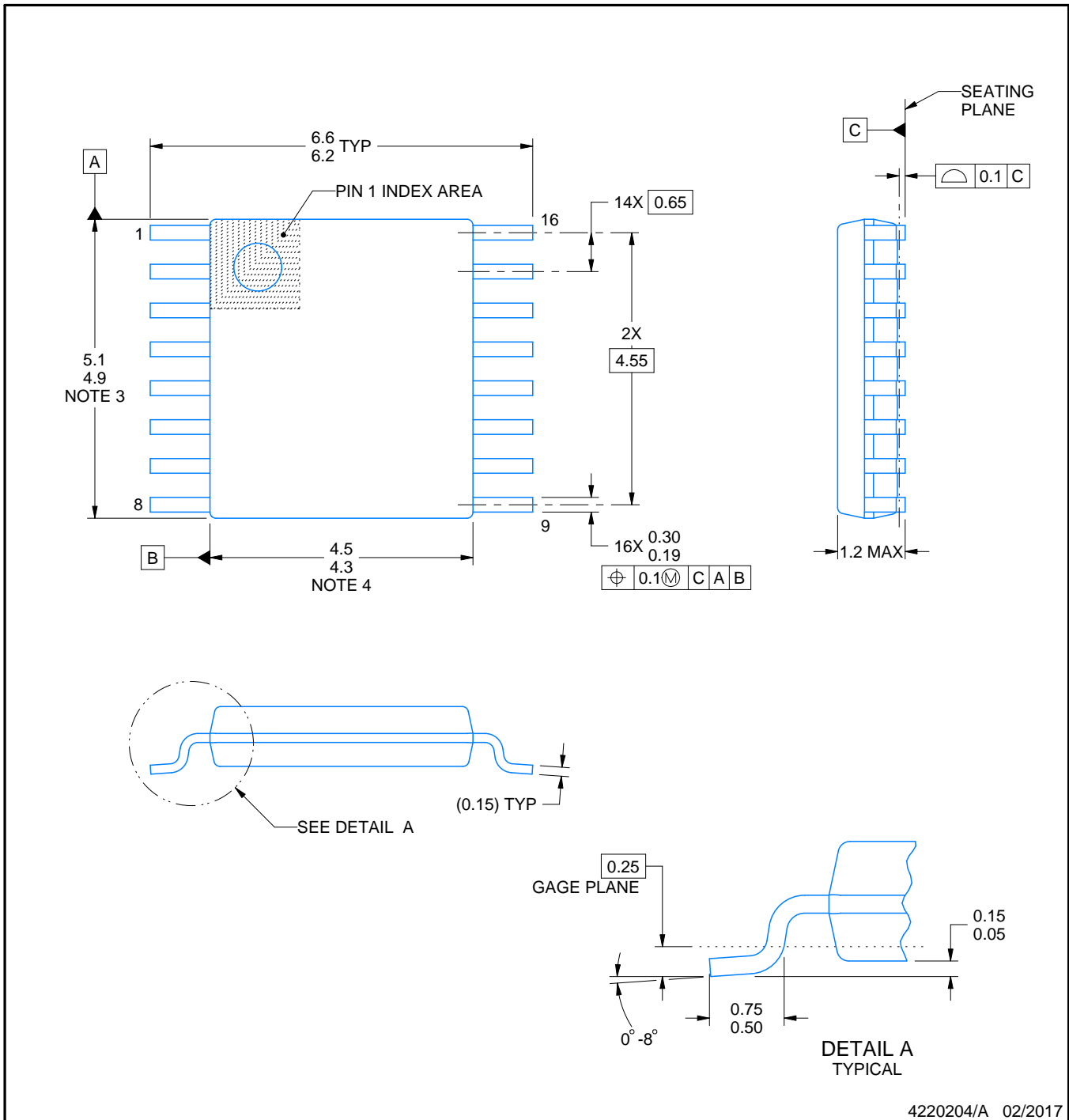
Device	Package Name	Package Type	Pins	SPQ	L (mm)	W (mm)	T (μm)	B (mm)
INA250A1PW	PW	TSSOP	16	90	530	10.2	3600	3.5
INA250A2PW	PW	TSSOP	16	90	530	10.2	3600	3.5
INA250A3PW	PW	TSSOP	16	90	530	10.2	3600	3.5
INA250A4PW	PW	TSSOP	16	90	530	10.2	3600	3.5



4220204/A 02/2017

NOTES:

1. All linear dimensions are in millimeters. Any dimensions in parenthesis are for reference only. Dimensioning and tolerancing per ASME Y14.5M.
2. This drawing is subject to change without notice.
3. This dimension does not include mold flash, protrusions, or gate burrs. Mold flash, protrusions, or gate burrs shall not exceed 0.15 mm per side.
4. This dimension does not include interlead flash. Interlead flash shall not exceed 0.25 mm per side.
5. Reference JEDEC registration MO-153.

EXAMPLE BOARD LAYOUT

PW0016A

TSSOP - 1.2 mm max height

SMALL OUTLINE PACKAGE



LAND PATTERN EXAMPLE
EXPOSED METAL SHOWN
SCALE: 10X



4220204/A 02/2017

NOTES: (continued)

- 6. Publication IPC-7351 may have alternate designs.
- 7. Solder mask tolerances between and around signal pads can vary based on board fabrication site.

EXAMPLE STENCIL DESIGN

PW0016A

TSSOP - 1.2 mm max height

SMALL OUTLINE PACKAGE

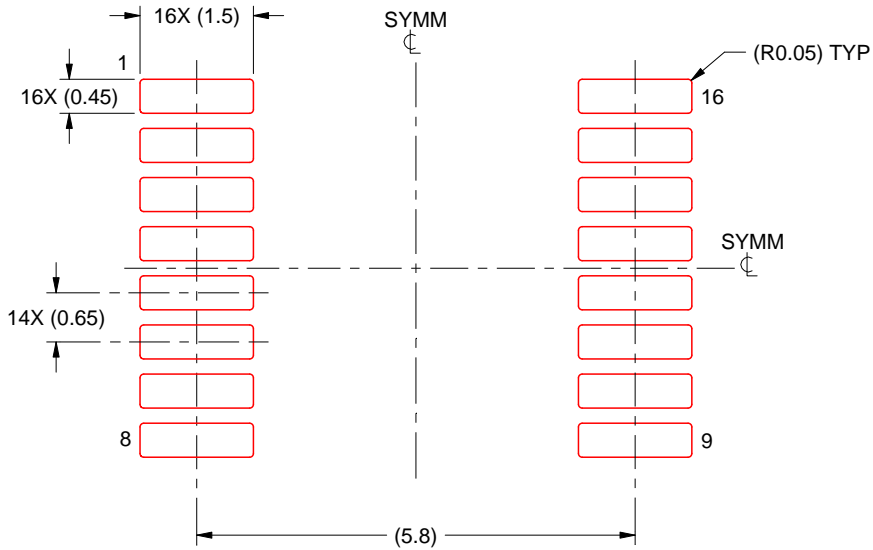

SOLDER PASTE EXAMPLE
BASED ON 0.125 mm THICK STENCIL
SCALE: 10X

4220204/A 02/2017

NOTES: (continued)

8. Laser cutting apertures with trapezoidal walls and rounded corners may offer better paste release. IPC-7525 may have alternate design recommendations.
9. Board assembly site may have different recommendations for stencil design.

IMPORTANT NOTICE AND DISCLAIMER

TI PROVIDES TECHNICAL AND RELIABILITY DATA (INCLUDING DATA SHEETS), DESIGN RESOURCES (INCLUDING REFERENCE DESIGNS), APPLICATION OR OTHER DESIGN ADVICE, WEB TOOLS, SAFETY INFORMATION, AND OTHER RESOURCES "AS IS" AND WITH ALL FAULTS, AND DISCLAIMS ALL WARRANTIES, EXPRESS AND IMPLIED, INCLUDING WITHOUT LIMITATION ANY IMPLIED WARRANTIES OF MERCHANTABILITY, FITNESS FOR A PARTICULAR PURPOSE OR NON-INFRINGEMENT OF THIRD PARTY INTELLECTUAL PROPERTY RIGHTS.

These resources are intended for skilled developers designing with TI products. You are solely responsible for (1) selecting the appropriate TI products for your application, (2) designing, validating and testing your application, and (3) ensuring your application meets applicable standards, and any other safety, security, regulatory or other requirements.

These resources are subject to change without notice. TI grants you permission to use these resources only for development of an application that uses the TI products described in the resource. Other reproduction and display of these resources is prohibited. No license is granted to any other TI intellectual property right or to any third party intellectual property right. TI disclaims responsibility for, and you will fully indemnify TI and its representatives against, any claims, damages, costs, losses, and liabilities arising out of your use of these resources.

TI's products are provided subject to [TI's Terms of Sale](#) or other applicable terms available either on [ti.com](https://www.ti.com) or provided in conjunction with such TI products. TI's provision of these resources does not expand or otherwise alter TI's applicable warranties or warranty disclaimers for TI products.

TI objects to and rejects any additional or different terms you may have proposed.

Mailing Address: Texas Instruments, Post Office Box 655303, Dallas, Texas 75265
Copyright © 2024, Texas Instruments Incorporated

Looking for pricing, stock, or lifecycle information?

Click below to explore more details on WIN SOURCE:

 [View INA250A2PWR](#) on WIN SOURCE

 [Texas Instruments](#) Information

Optimize Your Supply Chain with WIN SOURCE Solutions

-  Global Sourcing Solution
-  Obsolete Management
-  Cost Control Management
-  Shortage Management
-  Alternative Solution
-  Excess Inventory Management