



THE DATASHEET OF PACUSB-D1YB5R





PACUSB-D1/D2/D3

Features

- A low-capacitance USB downstream port terminator, EMI filter, and transient over-voltage (ESD) protector in a single surface-mounted package
- ESD protection to $\pm 20\text{kV}$ contact discharge, per MIL-STD-883D, Method 3015
- ESD protection to $\pm 15\text{kV}$ contact discharge, per IEC 61000-4-2 International Standard
- Compact SOT23-5 and SC70-5 package options save board space and lower manufacturing costs compared to discrete solutions
- Capacitors matched to a precision exceeding the USB specification
- Pin-compatible with ST Microelectronics USBDFxxW5 USB Downstream Port Terminator
- Lead-free versions available

Applications

- ESD protection and termination of USB downstream ports
- Desktop PCs
- Notebooks
- Set-top boxes
- USB hubs

Product Description

The PACUSB-D1/D2/D3 is a single-channel USB downstream-port termination network. It integrates EMI/RFI filter components R1 and C1, as recommended by the USB specification as well as the required 15kW pull-down resistors (R2) to GND. In addition, PACUSB-D1/D2/D3 provides a very high level of protection for sensitive electronic components that may be subjected to electrostatic discharge (ESD). The device pins will safely dissipate ESD strikes of $+15\text{kV}$, exceeding the maximum requirements of the IEC 61000-4-2 international standard. Using the MIL-STD-883D (Method 3015) specification for Human Body Model (HBM) ESD, all pins are protected from contact discharges to $+20\text{kV}$.

There are three options for the value of the series resistor R1: 15Ω , 22Ω , and 33Ω . This series resistance, plus the USB driver output resistance, must be close to the USB cable's characteristic impedance of 45Ω (each side) to minimize transmission line reflections.

The PACUSB-D1/D2/D3 is manufactured in a 5-pin SC70 or a 5-pin SOT23 package and is available with optional lead-free finishing..

PACUSB-D1/D2/D3

Electrical Schematic

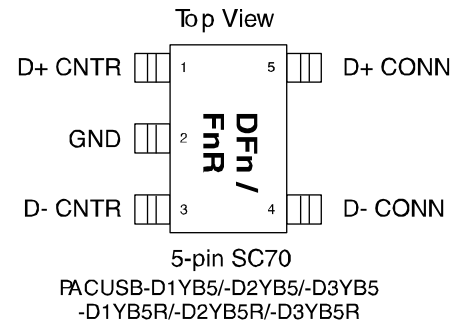
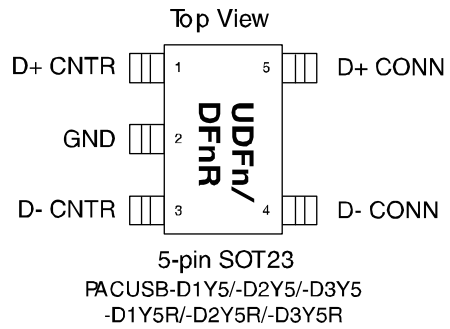
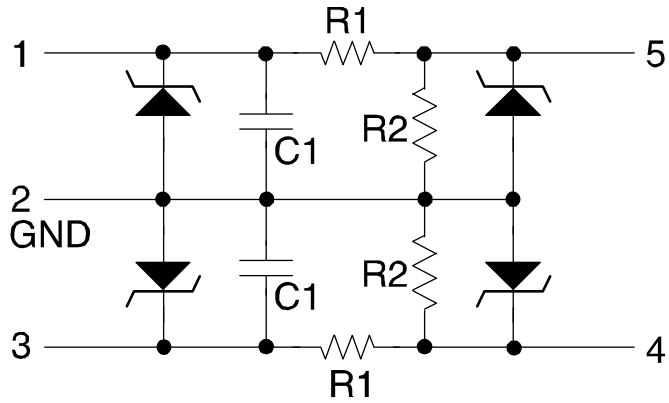

Note 1: The "n" shown in part markings above represents either the digit "1," "2," or "3."
 Note 2: SOT23 and SC70 package sizes may differ. These drawings are not to scale.

PIN DESCRIPTIONS

PINS	NAME	DESCRIPTION
1	D+ CNTR	D+ Data to the USB controller circuitry
2	GND	Ground Pin
3	D- CNTR	D- Data to the USB controller circuitry
4	D- CONN	D- Data to the USB connector
5	D+ CONN	D+ Data to the USB connector

Ordering Information

PART NUMBERING INFORMATION						
Pins	R1 Value	Package	Standard Finish		Lead-free Finish	
			Ordering Part Number ¹	Part Marking	Ordering Part Number ¹	Part Marking
5	15 Ω	SOT23-5	PACUSB-D2Y5	UDF2	PACUSB-D2Y5R	DF2R
	22 Ω		PACUSB-D3Y5	UDF3	PACUSB-D3Y5R	DF3R
	33 Ω		PACUSB-D1Y5	UDF1	PACUSB-D1Y5R	DF1R
5	15 Ω	SC70-5	PACUSB-D2YB5	DF2	PACUSB-D2YB5R	F2R
	22 Ω		PACUSB-D3YB5	DF3	PACUSB-D3YB5R	F3R
	33 Ω		PACUSB-D1YB5	DF1	PACUSB-D1YB5R	F1R

Note 1: Parts are shipped in Tape & Reel form unless otherwise specified.

Specifications

ABSOLUTE MAXIMUM RATINGS		
PARAMETER	RATING	UNITS
Storage Temperature Range	-65 to +150	°C
Power Dissipation per Resistor	100	mW
Package Power Dissipation	200	mW
Voltage on any pin (DC)	6	V

STANDARD OPERATING CONDITIONS		
PARAMETER	RATING	UNITS
Operating Temperature	-40 to +85	°C

PACUSB-D1/D2/D3

ELECTRICAL OPERATING CHARACTERISTICS (SEE NOTE 1)

SYMBOL	PARAMETER	CONDITIONS	MIN	TYP	MAX	UNITS
R1	Resistance of R1 Resistor (PACUSB-D2Y5/Y5R, -D2YB5/YB5R)	$T_A = 25^\circ\text{C}$	12	15	18	Ω
R1	Resistance of R1 Resistor (PACUSB-D3Y5/Y5R, -D3YB5/YB5R)	$T_A = 25^\circ\text{C}$	17.6	22	26.4	Ω
R1	Resistance of R1 Resistor (PACUSB-D1Y5/Y5R, -D1YB5/YB5R)	$T_A = 25^\circ\text{C}$	26.4	33	39.6	Ω
R2	Resistance of R2 Resistor	$T_A = 25^\circ\text{C}$		15		$k\Omega$
TCR	Temperature Coefficient of Resistance	Note 1		± 1300		ppm/ $^\circ\text{C}$
C1	Capacitance of C1 Capacitor	0 VDC; 30 mVAC; 1MHz; 25°C	37.6	47	56.4	pF
		2.5 VDC; 30 mVAC; 1MHz; 25°C	25.6	32	38.4	pF
TOL _{CM}	Matching Tolerance of C1 Capacitors	1MHz; 25°C			± 2	%
I _{LEAK}	Diode Leakage Current to GND	Measured at 3.3 VDC, 25°C		1	100	nA
V _{RB}	Diode Reverse Bias Voltage	I _{LOAD} = 10 μA ; $T_A = 25^\circ\text{C}$	5.5			V
V _{SIG}	Signal Voltage: Positive Clamp Negative Clamp	I _{LOAD} = 10mA; $T_A = 25^\circ\text{C}$	5.6	6.8	9.0	V
		I _{LOAD} = 10mA; $T_A = 25^\circ\text{C}$	-0.4	-0.8	-1.5	V
V _{ESD}	In-system ESD Withstand Voltage MIL-STD-883D, Method 3015 (HBM) IEC 61000-4-2 Contact Discharge	Pins 1, 3; Notes 2 and 3	± 4			kV
		Pins 4, 5; Note 2	± 20			kV
		Pins 4, 5; Notes 2	± 15			kV
V _{CL}	Clamping voltage under ESD discharge	MIL-STD-883D, Method 3015 +8kV; Note 4		12		V
		MIL-STD-883D, Method 3015 - 8kV; Note 4		-7		V

Note 1: Electrical operating characteristics guaranteed over standard operating conditions unless specified otherwise.

Note 2: ESD voltage applied to pins with respect to GND, one at a time; unused pins are left open.

Note 3: Pins 1 and 3 are not connected to the USB port connector, and therefore are not exposed to external ESD hazards. Thus, they do not require the high ESD protection levels provided for pins 4 and 5.

Note 4: ESD Clamping Voltage is measured at the opposite end of R1 from the pin to which the ESD discharge is applied (e.g., if ESD is applied to pin 6, then the clamping voltage is measured at pin 1).

Performance Information

Capacitance vs. Voltage

The C1 capacitance value as a function of DC voltage across it is presented in [Figure 1](#). The curve is normalized to a capacitance of 1.0 capacitance units at 2.5 VDC.

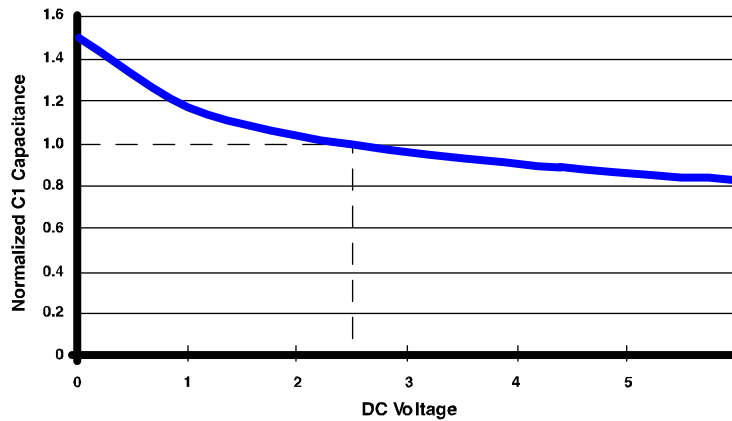

Figure 1. Diode Capacitance vs. DC Voltage (Normalized)

Insertion Loss vs. Frequency Characteristics

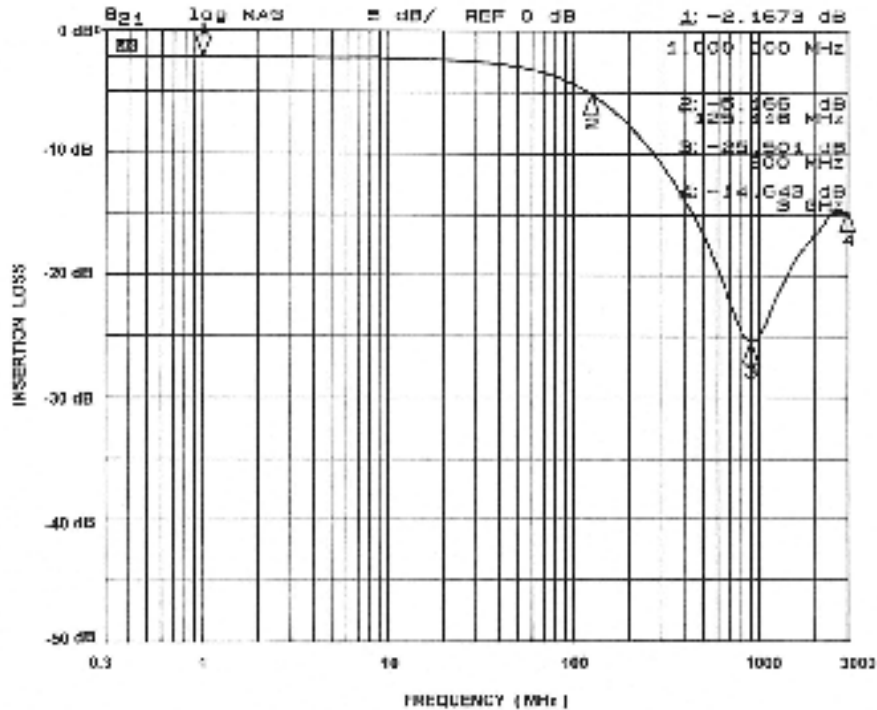

Figure 2. Insertion Loss vs. Frequency Performance Curve, PACUSB-D1(SOT23-6)

PACUSB-D1/D2/D3

Performance Information (cont'd)

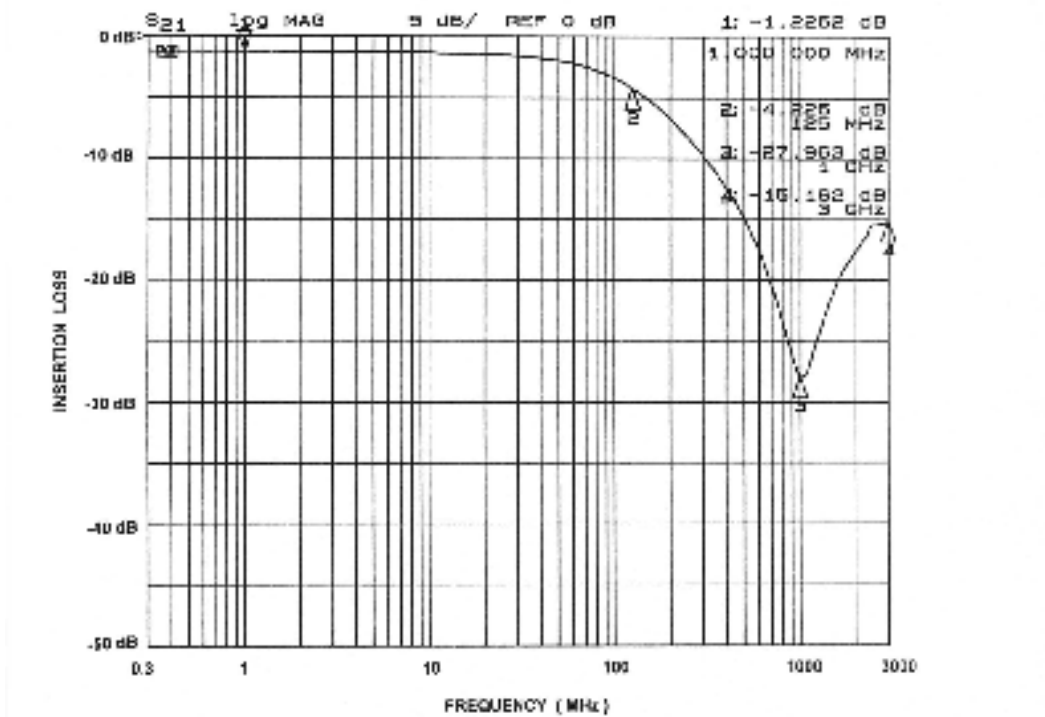
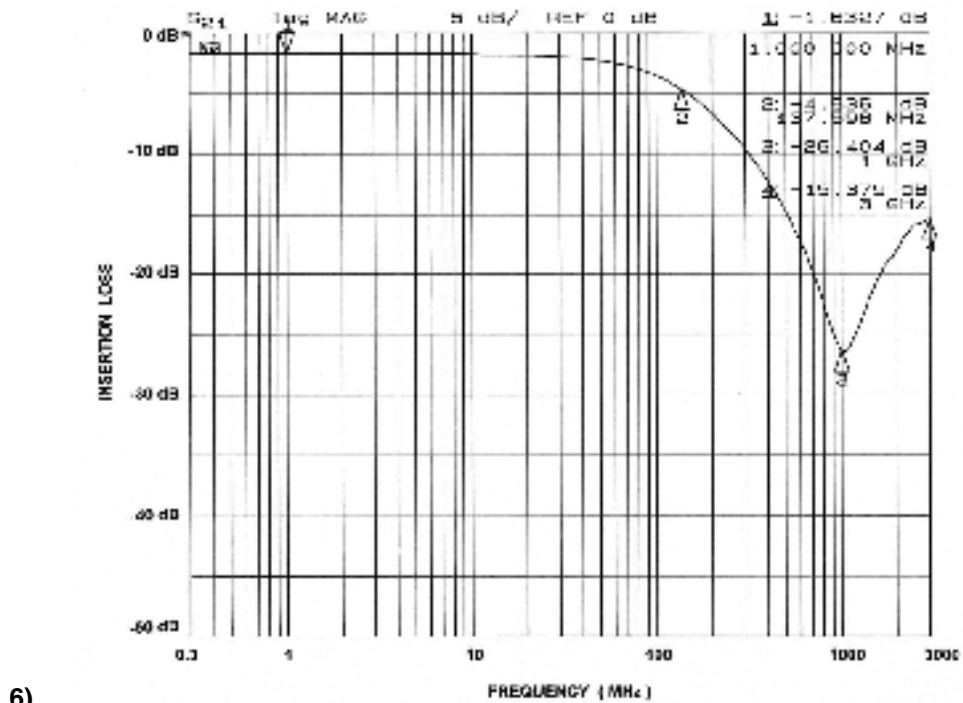

Figure 3. Insertion Loss vs. Frequency Performance Curve, PACUSB-D2(SOT23-6)



6)

Figure 4. Insertion Loss vs. Frequency Performance Curve, PACUSB-D3(SOT23-6)

Application Information

The PACUSB-D1/D2/D3 provides a complete interface for a single downstream USB port typically found in computers and USB hubs. It integrates the series resistors (R1) and the 15kΩ pull-down resistors (R2) for both USB data lines (D+ and D-) as well as the capacitors to ground for EMI suppression. Zener diodes provide ESD protection up to 15kV contact discharge per the IEC 61000-4-2 standard and protect the USB controller on both data lines.

The PACUSB-D1/D2/D3 should be placed on the PCB between the USB controller and the USB connector, as shown on the Connection Diagram, Figure 5.

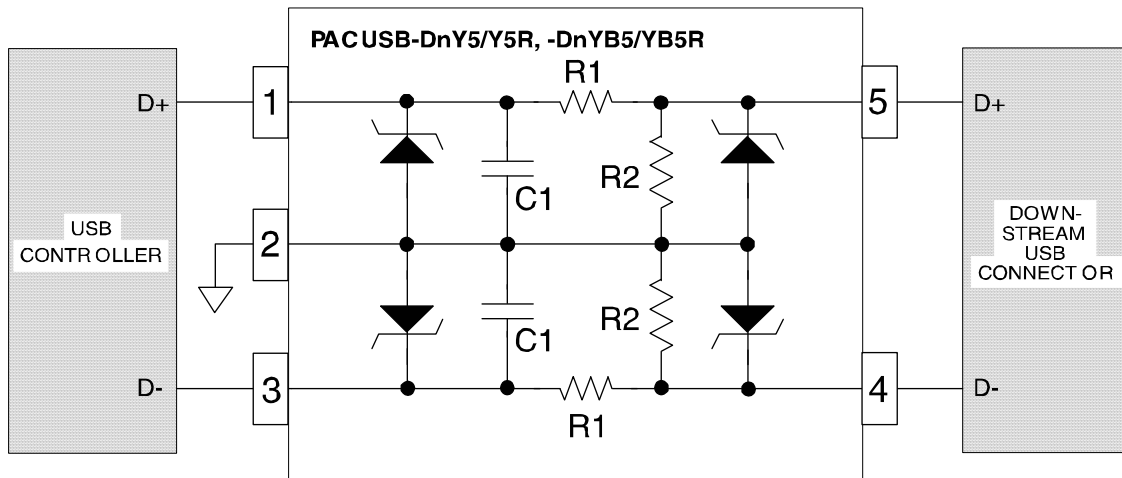

Figure 5. Connection Diagram for PACUSB-D1/D2/D3 Devices

To guarantee the best ESD and filtering performance, it is recommended to physically locate the PACUSB-D1/D2/D3 close to the USB connector. Also, the trace lengths between the PACUSB-D1/D2/D3 and the USB controller should be kept as short as possible.

PACUSB-D1/D2/D3

Mechanical Details

PACUSB-D1/D2/D3 devices are packaged in SOT23-5 and SC70-5 packages.

SOT23-5 Mechanical Specifications:

Dimensions for PACUSB-D1/D2/D3 devices packaged in a 5-pin SOT23 package are presented below. For complete information on the SOT23-5 package, see the California Micro Devices SOT23 Package Information document.

PACKAGE DIMENSIONS				
Package	SOT23-5 (JEDEC name is MO-178)			
Pins	5			
Dimensions	Millimeters		Inches	
	Min	Max	Min	Max
A	--	1.45	--	0.057
A1	0.00	0.15	0.000	0.006
b	0.30	0.50	0.012	0.020
c	0.08	0.22	0.003	0.009
D	2.75	3.05	0.108	0.120
E	2.60	3.00	0.102	0.118
E1	1.45	1.75	0.057	0.069
e	0.95 BSC		0.0374 BSC	
e1	1.90 BSC		0.0748 BSC	
L	0.30	0.60	0.0236	0.024
L1	0.60 REF		0.024 REF	
# per tape and reel	3000 pieces*			
Controlling dimension: millimeters				

* This is an approximate amount which may vary.

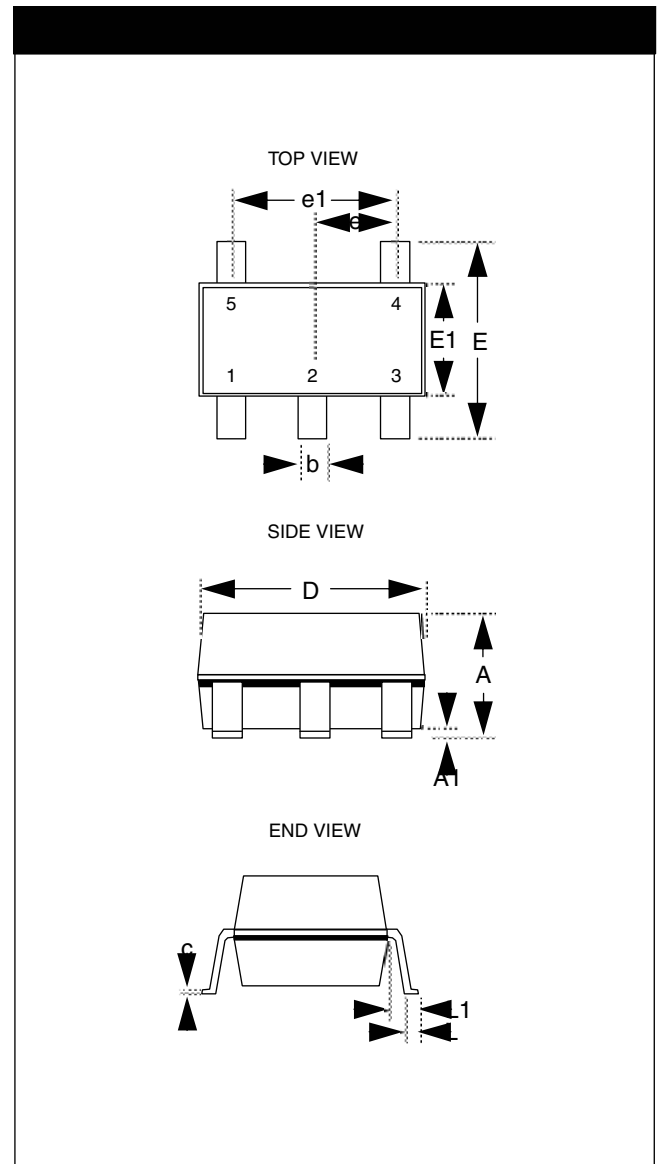

Package Dimensions for SOT23-5.

Mechanical Details (continued)

SC70-5 Mechanical Specifications:

Dimensions for PACUSB-D1/D2/D3 devices packaged in a 5-pin SC70 package are presented below. For complete information on the SC70-5 package, see the California Micro Devices SC70 Package Information document.

PACKAGE DIMENSIONS		
Package	SC70-5 (JEDEC name is MO-203 Issue A)	
Pins	5	
Dimensions	Millimeters	
	Min	Max
A	0.80	1.10
A1	0.00	0.10
A2	0.70	1.00
B	0.15	0.30
c	0.08	0.25
D	1.85	2.25
E	1.15	1.35
e	0.65 BSC	
HE	2.00	2.40
L	0.26	0.46
# / bag	1000 pieces*	
# / tape and reel	3000 pieces*	

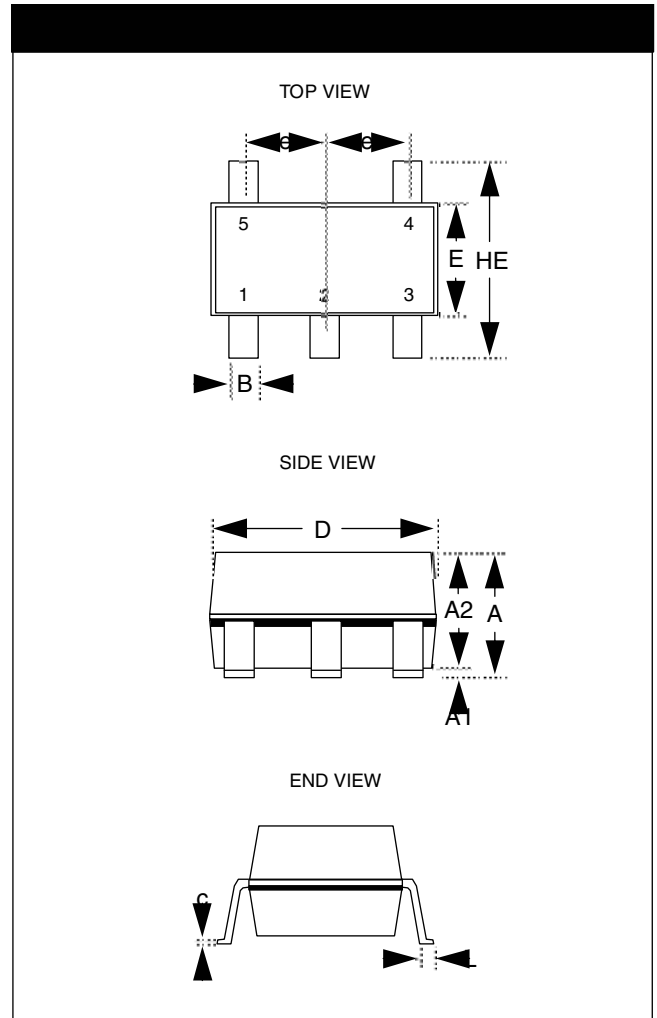

Package Dimensions for SC70-5.

* This is an approximate amount which may vary.

PACUSB-D1/D2/D3

ON Semiconductor and  are registered trademarks of Semiconductor Components Industries, LLC (SCILLC). SCILLC reserves the right to make changes without further notice to any products herein. SCILLC makes no warranty, representation or guarantee regarding the suitability of its products for any particular purpose, nor does SCILLC assume any liability arising out of the application or use of any product or circuit, and specifically disclaims any and all liability, including without limitation special, consequential or incidental damages. "Typical" parameters which may be provided in SCILLC data sheets and/or specifications can and do vary in different applications and actual performance may vary over time. All operating parameters, including "Typicals" must be validated for each customer application by customer's technical experts. SCILLC does not convey any license under its patent rights nor the rights of others. SCILLC products are not designed, intended, or authorized for use as components in systems intended for surgical implant into the body, or other applications intended to support or sustain life, or for any other application in which the failure of the SCILLC product could create a situation where personal injury or death may occur. Should Buyer purchase or use SCILLC products for any such unintended or unauthorized application, Buyer shall indemnify and hold SCILLC and its officers, employees, subsidiaries, affiliates, and distributors harmless against all claims, costs, damages, and expenses, and reasonable attorney fees arising out of, directly or indirectly, any claim of personal injury or death associated with such unintended or unauthorized use, even if such claim alleges that SCILLC was negligent regarding the design or manufacture of the part. SCILLC is an Equal Opportunity/Affirmative Action Employer. This literature is subject to all applicable copyright laws and is not for resale in any manner.

PUBLICATION ORDERING INFORMATION

LITERATURE FULFILLMENT:

Literature Distribution Center for ON Semiconductor
P.O. Box 5163, Denver, Colorado 80217 USA
Phone: 303-675-2175 or 800-344-3860 Toll Free USA/Canada
Fax: 303-675-2176 or 800-344-3867 Toll Free USA/Canada
Email: orderlit@onsemi.com

N. American Technical Support: 800-282-9855
Toll Free USA/Canada
Europe, Middle East and Africa Technical Support:
Phone: 421 33 790 2910
Japan Customer Focus Center
Phone: 81-3-5773-3850

ON Semiconductor Website: www.onsemi.com

Order Literature: <http://www.onsemi.com/orderlit>

For additional information, please contact your local Sales Representative

Looking for pricing, stock, or lifecycle information?

Click below to explore more details on WIN SOURCE:

- ⊖ [View PACUSB-D1YB5R on WIN SOURCE](#)
- ⊖ [ON Semiconductor](#) Information

Optimize Your Supply Chain with WIN SOURCE Solutions

- ✓ Global Sourcing Solution
- ✓ Obsolete Management
- ✓ Cost Control Management
- ✓ Shortage Management
- ✓ Alternative Solution
- ✓ Excess Inventory Management