



**THE DATASHEET OF
NCS6433DTBR2G**



NCS6433

Wideband Quad 2:1 Video Switch

The NCS6433 is a wide bandwidth, bidirectional, Quad 2:1, NMOS-based video switch suitable for dealing with video signals such as RGB, composite, S-Video, and component video (YPbPr).

The NCS6433 is controlled by a single switch-enabled (\overline{OE}) input. When \overline{OE} is low the switch is enabled and the A port is connected to the B port. When \overline{OE} is high the switch is disabled and the high-impedance state exists between the A and B ports. The line select (SEL) input controls the data path of the multiplexer/demultiplexer.

The NCS6433 has a wide bandwidth, low crosstalk, low on resistance, and fast switching times making it suitable for high-frequency video applications in high definition LCD TV's.

Features

- Very Wide Frequency Bandwidth: 570 MHz
- Low Switch Serial Resistance $R_{DS(on)}$, 4 Ω Typical
- Power Supply Voltage, 5 V
- Less Than 0.25 ns Bidirectional Maximum Propagation Delay Through Switch
- Low Quiescent Current: 3 μ A Maximum
- Very Low Crosstalk, -80 dB Typical at 10 MHz
- Control Inputs are TTL/CMOS Compatible
- Ideal for High Definition Video Applications
- ESD HBM Protection 8 kV
- Fast Switching – Better Than 10 ns
- Capable of Driving a High Current at the Output (>100 mA)
- Available in SOIC-16 or TSSOP-16 Package
- This is a Pb-Free Device

Typical Applications

- Flat Panel Displays including LCDTV
- CRT Displays
- DVD Reader/Writer
- Set-Top Boxes



ON Semiconductor®

<http://onsemi.com>



MARKING DIAGRAMS

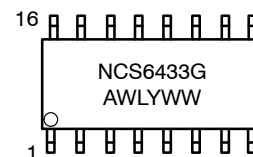
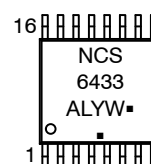

- A = Assembly Location
- WL, L = Wafer Lot
- Y = Year
- WW, W = Work Week
- G or \blacksquare = Pb-Free Package

(Note: Microdot may be in either location)

PIN CONNECTIONS

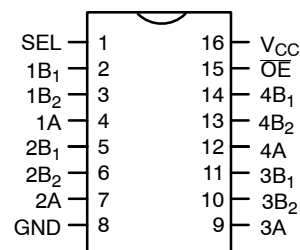

TRUTH TABLE

SEL	OE	Function
X	H	Open
L	L	A = B ₁
H	L	A = B ₂

PIN NAMES

Pin	Description
\overline{OE}	Bus Switch Enables
SEL	Select Inputs
A	Bus A
B ₁ , B ₂	Bus B

ORDERING INFORMATION

See detailed ordering and shipping information in the package dimensions section on page 2 of this data sheet.

NCS6433

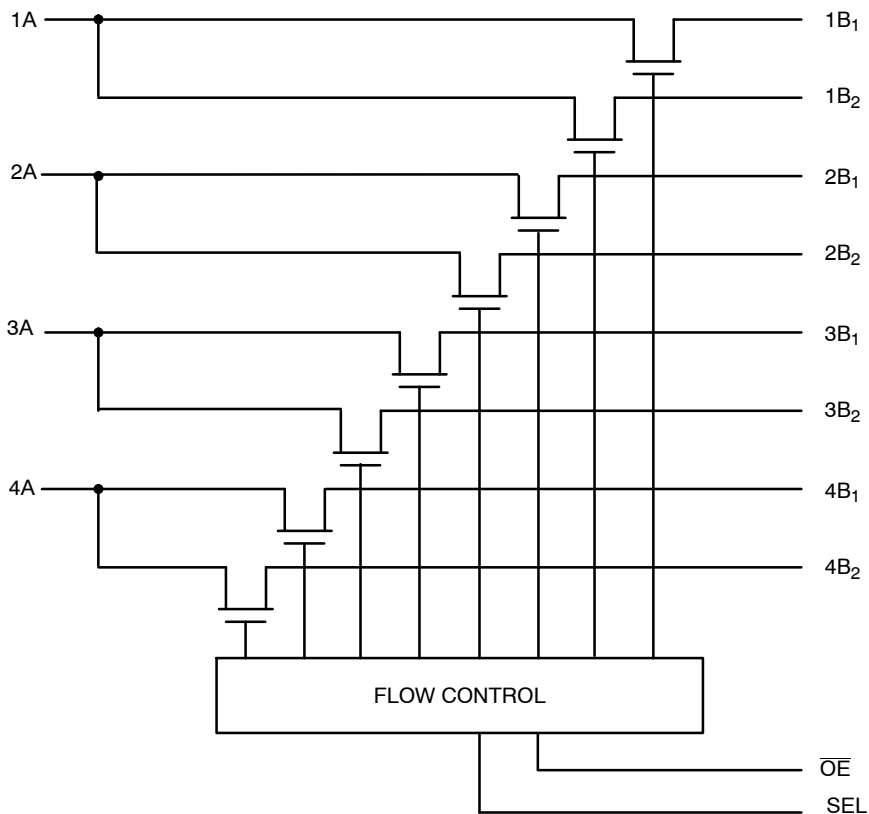

Figure 1. NCS6433 Block Diagram

ORDERING INFORMATION

Device Order Number	Package	Shipping†
NCS6433DR2G	SOIC-16 (Pb-Free)	2500 / Tape & Reel
NCS6433DTBR2G	TSSOP-16 (Pb-Free)	2500 / Tape & Reel

†For information on tape and reel specifications, including part orientation and tape sizes, please refer to our Tape and Reel Packaging Specifications Brochure, BRD8011/D.

NCS6433

ATTRIBUTES

Characteristics	Value
ESD Protection Human Body Model, R = 1000 Ω , C = 100 pF I/O Pins 2–7, 9–14 (Note 1) Machine Model	8 kV 2 kV 100 V
Flammability Rating	Oxygen Index: 28 to 34
UL 94 V-0 @ 0.125 in.	
Meets or exceeds JEDEC Spec EIA/JESD78 IC Latch-up Test	

1. Meets or exceeds JEDEC spec JESD22–A114–B.
2. For additional information, see Application Note AND8003/D

MAXIMUM RATINGS

Parameter	Symbol	Value	Unit
DC Supply Voltage	V_{CC}	–0.5 to +5.5	V
DC Input Voltage	V_I	–0.5 to +5.5	V
DC Output Voltage	V_O	–0.5 to +5.5	V
DC Input Diode Current	I_{IK}	–50	mA
DC Output Diode Current	I_{OK}	–50	mA
DC Output Sink Current	I_O	128	mA
DC Supply Current per Supply Pin	I_{CC}	± 100	mA
DC Ground Current per Ground Pin	I_{GND}	± 100	mA
Storage Temperature Range	T_{STG}	–65 to +150	$^{\circ}\text{C}$
Lead Temperature, 1 mm from Case for 10 Seconds	T_L	260	$^{\circ}\text{C}$
Junction Temperature Under Bias (Note 3)	T_J	+150	$^{\circ}\text{C}$
Thermal Resistance	θ_{JA}	125 170	$^{\circ}\text{C}/\text{W}$
	SOIC–16 TSSOP–16		

Stresses exceeding Maximum Ratings may damage the device. Maximum Ratings are stress ratings only. Functional operation above the Recommended Operating Conditions is not implied. Extended exposure to stresses above the Recommended Operating Conditions may affect device reliability.

3. Maximum electrical ratings are defined as those values beyond which damage to the device may occur at $T_A = +25^{\circ}\text{C}$.

RECOMMENDED OPERATING CONDITIONS

Symbol	Parameter	Min	Max	Unit
V_{CC}	Supply Voltage Operating, Data Retention Only	4.75	5.25	V
V_I	Input Voltage (Note 4)	0	5.25	V
V_O	Output Voltage (HIGH or LOW State)	0	5.25	V
T_A	Operating Free–Air Temperature	–40	+85	$^{\circ}\text{C}$
$\Delta t/\Delta V$	Input Transition Rise or Fall Rate Switch I/O	0	DC 5	ns/V
	Switch Control Input $V_{CC} = 5.0 \text{ V} \pm 0.5 \text{ V}$			

4. Unused control inputs may not be left open. All control inputs must be tied to a high or low logic input voltage level.

NCS6433

DC ELECTRICAL CHARACTERISTICS ($T_A = -40^\circ\text{C}$ to $+85^\circ\text{C}$ for Min and Max values, $T_A = 25^\circ\text{C}$ for Typ values)

Symbol	Parameter	Conditions	V_{CC} (V)	Min	Typ*	Max	Unit
V_{IK}	Clamp Diode Voltage	$I_{IN} = -18\text{ mA}$	4.5	-1.2	-0.8		V
V_{IH}	High-Level Input Voltage		4.0 to 5.5	2.0			V
V_{IL}	Low-Level Input Voltage		4.0 to 5.5			0.8	V
I_{LI}	Input Leakage Current	$0 \leq V_{IN} \leq 5.5\text{ V}$	5.5			± 1.0	μA
I_{OZ}	Off-State Leakage Current	$0 \leq A, B \leq V_{CC}$	5.5			± 1.0	μA
R_{ON}	Switch On Resistance (Note 5)	$V_{IN} = 1\text{ V}, I_{ON} = 13\text{ mA}, R_L = 75\ \Omega$	4.5		4.0	7.0	Ω
		$V_{IN} = 2\text{ V}, I_{ON} = 26\text{ mA}, R_L = 75\ \Omega$	4.5		7.0	10	
I_{CC}	Quiescent Supply Current	$V_{IN} = V_{CC}$ or GND, $I_{OUT} = 0$	5.5			3.0	μA
ΔI_{CC}	Increase In I_{CC} per Input	One input at 3.4 V, Other inputs at V_{CC} or GND	5.5			2.5	mA

*Typical values are at $V_{CC} = 5.0\text{ V}$ and $T_A = 25^\circ\text{C}$.

5. Measured by the voltage drop between A and B pins at the indicated current through the switch. On resistance is determined by the lower of the voltages on the two (A or B) pins.

AC ELECTRICAL CHARACTERISTICS ($T_A = -40^\circ\text{C}$ to $+85^\circ\text{C}$, $C_L = 20\text{ pF}$, $R_U = R_D = 75\ \Omega$ unless otherwise specified) (Note 6)

Symbol	Parameter	Conditions	$V_{CC} = 4.5\text{--}5.5\text{ V}$			Unit
			Min	Typ	Max	
t_{ON}	Turn On Time	$R_L = 75\ \Omega, C_L = 20\text{ pF}$, see Figure 7		2.8	5.0	ns
t_{OFF}	Turn Off Time	$R_L = 75\ \Omega, C_L = 20\text{ pF}$, see Figure 7		1.4	5.0	ns
BW	-3 dB Bandwidth	$R_L = 150\ \Omega, T_A = 25^\circ\text{C}$			570	MHz
X_{talk}	Crosstalk Adjacent Non-Adjacent	10 MHz, $C_L = 0\text{ pF}, R_L = 150\ \Omega$		-47 -80		dB
Off_{ISO}	Off Isolation	10 MHz, $C_L = 0\text{ pF}, R_L = 150\ \Omega$		-48		dB

6. $T_A = +25^\circ\text{C}$, parameters characterized but not tested.

CAPACITANCES (Note 7)

Symbol	Parameter	Conditions	Min	Typ	Max	Unit
C_{IN}	Control Pin Input Capacitance	$V_{CC} = 5.0\text{ V}$		2.0		pF
$C_{I/OA}$	A Port Input/Output Capacitance	$V_{CC} = \overline{OE} = 5.0\text{ V}$		5.0		pF
$C_{I/OB}$	B Port Input/Output Capacitance	$V_{CC} = \overline{OE} = 5.0\text{ V}$		5.0		pF

7. $T_A = +25^\circ\text{C}$, $f = 1\text{ MHz}$, Capacitance is characterized but not tested.

TYPICAL CHARACTERISTICS

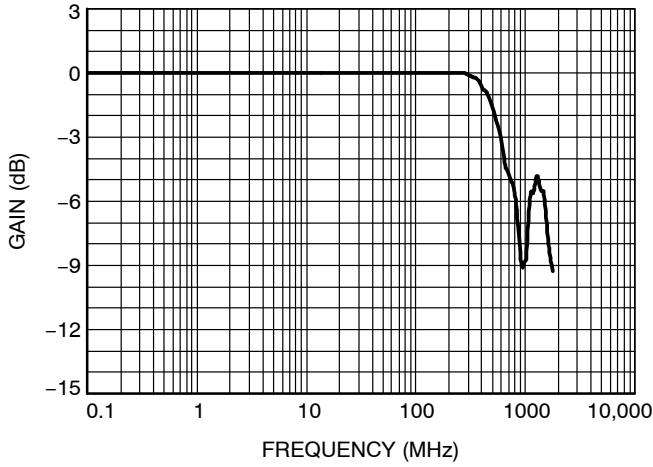

Figure 2. Gain vs. Frequency

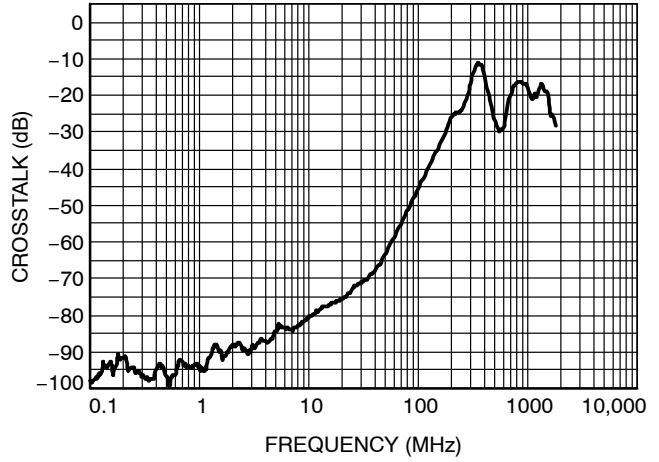

Figure 3. Crosstalk vs. Frequency (Non-Adjacent Channels)

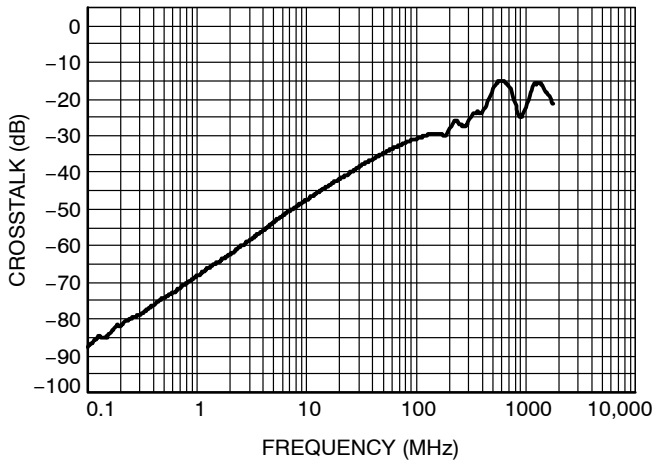

Figure 4. Crosstalk vs. Frequency (Adjacent Channels)

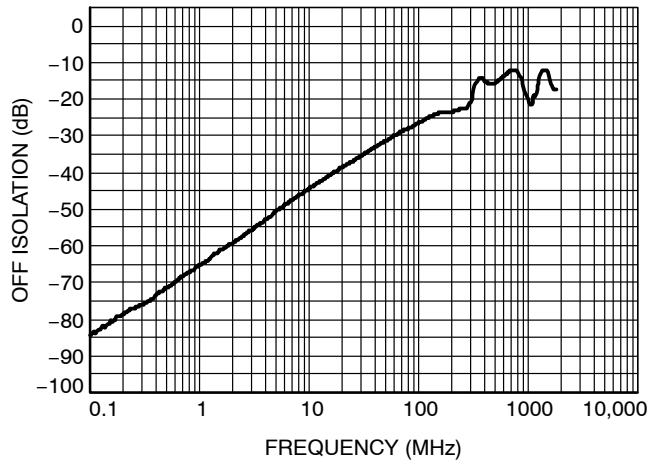

Figure 5. Off Isolation vs. Frequency

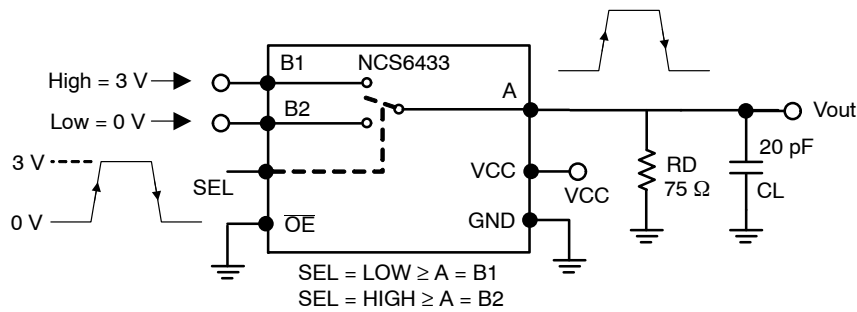

Figure 6. AC Test Circuit for Turn-on and Turn-off Times

NCS6433

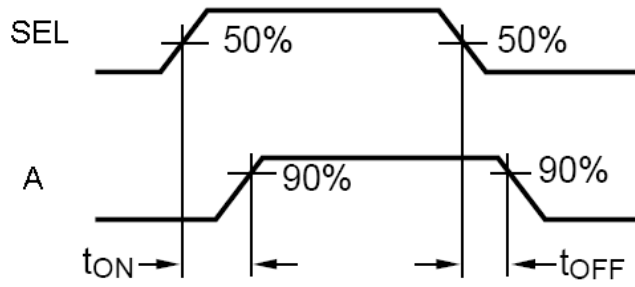

Figure 7. Turn-on and Turn-off Times

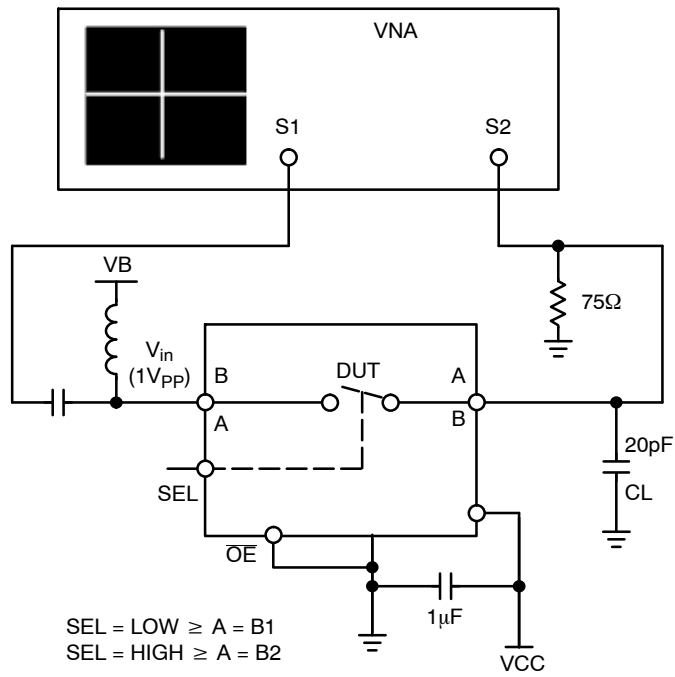

Figure 8. Gain, Crosstalk, Off-Isolation

NCS6433

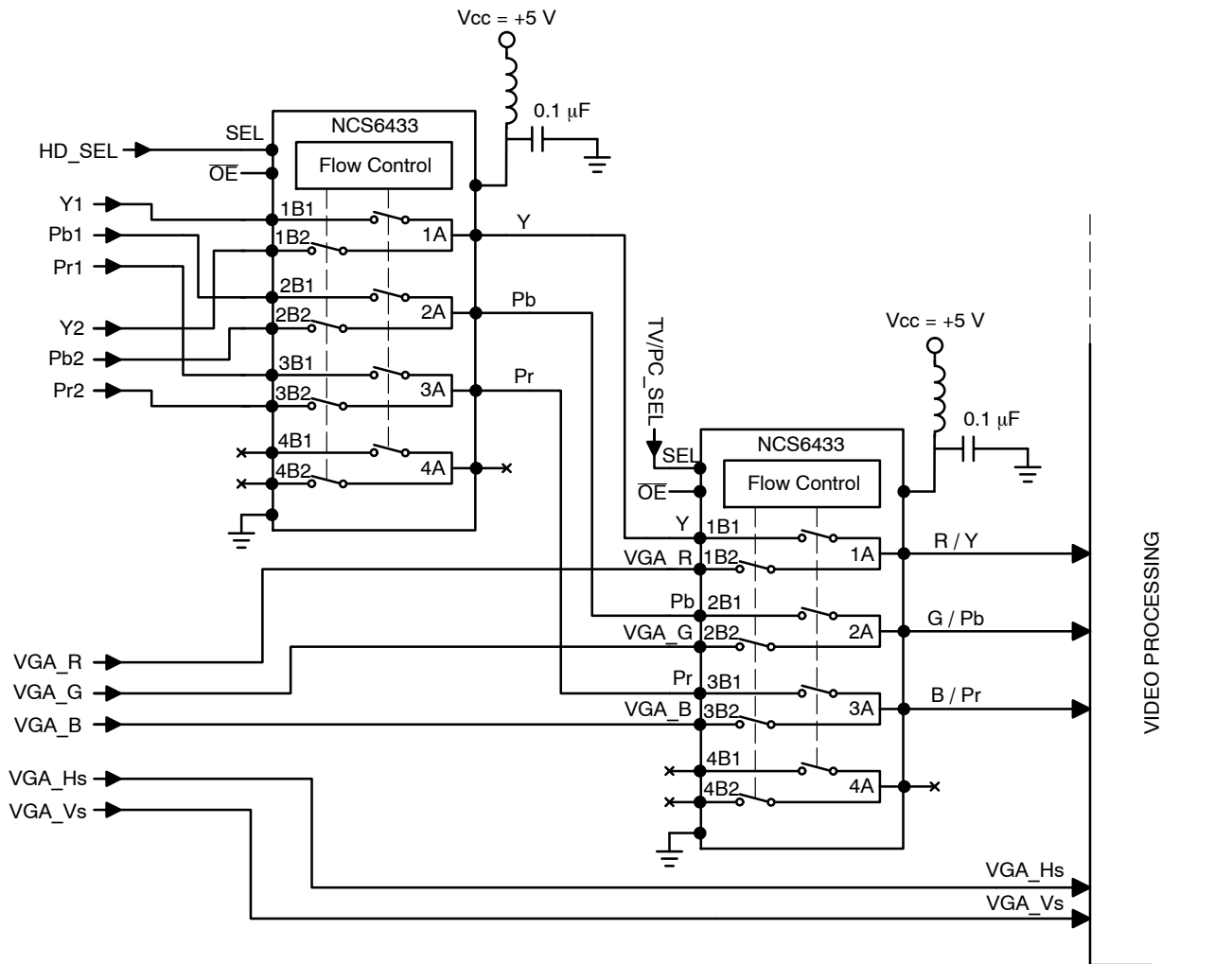
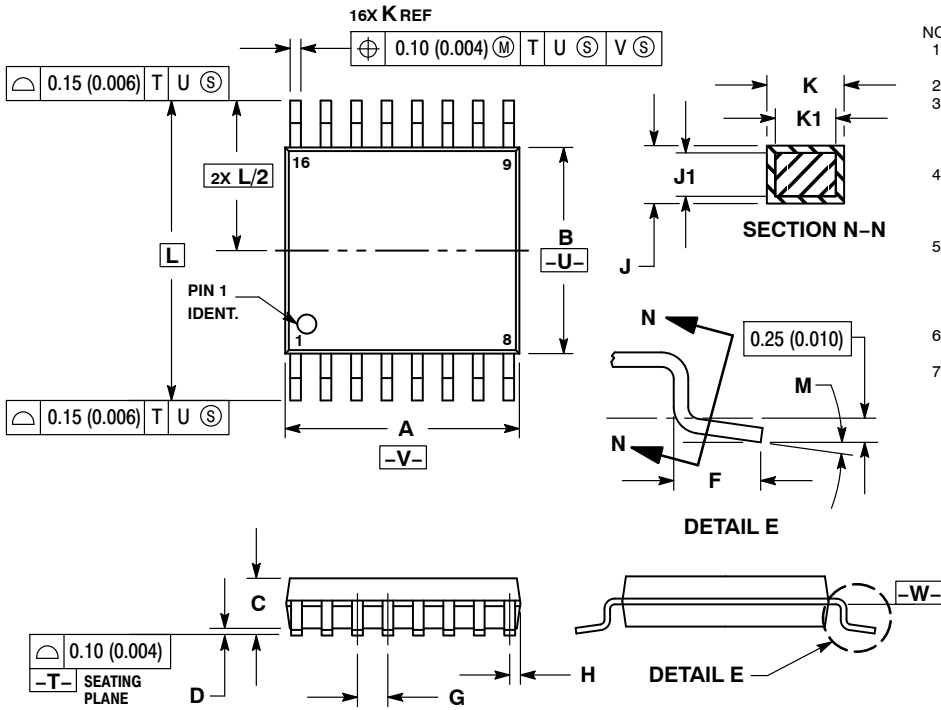

Figure 9. Example of LCDTV Application Using the Video Switch NCS6433

NCS6433

PACKAGE DIMENSIONS

TSSOP-16
CASE 948F-01
ISSUE B



- NOTES:
1. DIMENSIONING AND TOLERANCING PER ANSI Y14.5M, 1982.
 2. CONTROLLING DIMENSION: MILLIMETER.
 3. DIMENSION A DOES NOT INCLUDE MOLD FLASH. PROTRUSIONS OR GATE BURRS. MOLD FLASH OR GATE BURRS SHALL NOT EXCEED 0.15 (0.006) PER SIDE.
 4. DIMENSION B DOES NOT INCLUDE INTERLEAD FLASH OR PROTRUSION. INTERLEAD FLASH OR PROTRUSION SHALL NOT EXCEED 0.25 (0.010) PER SIDE.
 5. DIMENSION K DOES NOT INCLUDE DAMBAR PROTRUSION. ALLOWABLE DAMBAR PROTRUSION SHALL BE 0.08 (0.003) TOTAL IN EXCESS OF THE K DIMENSION AT MAXIMUM MATERIAL CONDITION.
 6. TERMINAL NUMBERS ARE SHOWN FOR REFERENCE ONLY.
 7. DIMENSION A AND B ARE TO BE DETERMINED AT DATUM PLANE -V-.

DIM	MILLIMETERS		INCHES	
	MIN	MAX	MIN	MAX
A	4.90	5.10	0.193	0.200
B	4.30	4.50	0.169	0.177
C	---	1.20	---	0.047
D	0.05	0.15	0.002	0.006
F	0.50	0.75	0.020	0.030
G	0.65 BSC		0.026 BSC	
H	0.18	0.28	0.007	0.011
J	0.09	0.20	0.004	0.008
J1	0.09	0.16	0.004	0.006
K	0.19	0.30	0.007	0.012
K1	0.19	0.25	0.007	0.010
L	6.40 BSC		0.252 BSC	
M	0°	8°	0°	8°

SOLDERING FOOTPRINT*

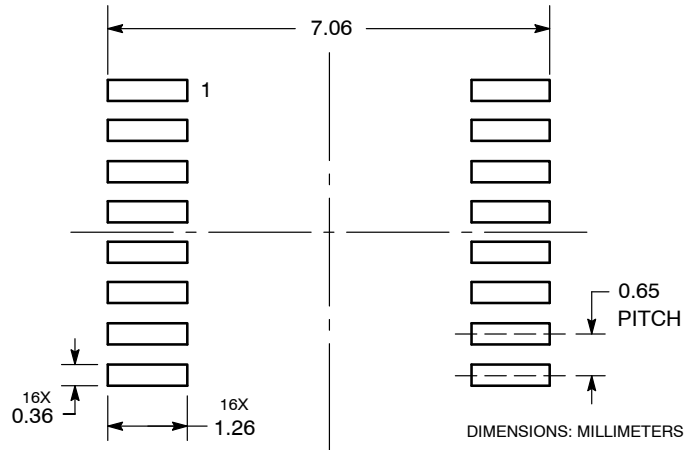

*For additional information on our Pb-Free strategy and soldering details, please download the ON Semiconductor Soldering and Mounting Techniques Reference Manual, SOLDERRM/D.

NCS6433

PACKAGE DIMENSIONS

SOIC-16
D SUFFIX
CASE 751B-05
ISSUE K

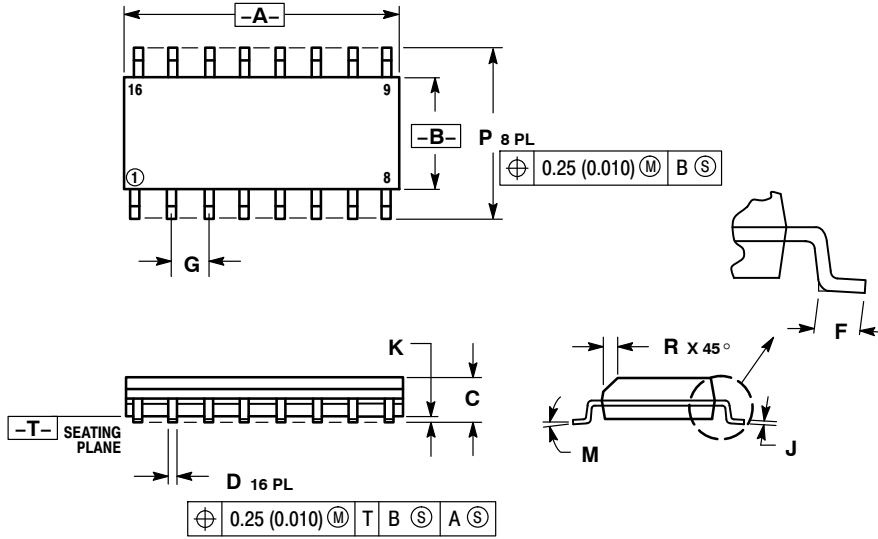

NOTES:

1. DIMENSIONING AND TOLERANCING PER ANSI Y14.5M, 1982.
2. CONTROLLING DIMENSION: MILLIMETER.
3. DIMENSIONS A AND B DO NOT INCLUDE MOLD PROTRUSION.
4. MAXIMUM MOLD PROTRUSION 0.15 (0.006) PER SIDE.
5. DIMENSION D DOES NOT INCLUDE DAMBAR PROTRUSION. ALLOWABLE DAMBAR PROTRUSION SHALL BE 0.127 (0.005) TOTAL IN EXCESS OF THE D DIMENSION AT MAXIMUM MATERIAL CONDITION.

DIM	MILLIMETERS		INCHES	
	MIN	MAX	MIN	MAX
A	9.80	10.00	0.386	0.393
B	3.80	4.00	0.150	0.157
C	1.35	1.75	0.054	0.068
D	0.35	0.49	0.014	0.019
F	0.40	1.25	0.016	0.049
G	1.27 BSC		0.050 BSC	
J	0.19	0.25	0.008	0.009
K	0.10	0.25	0.004	0.009
M	0°	7°	0°	7°
P	5.80	6.20	0.229	0.244
R	0.25	0.50	0.010	0.019

SOLDERING FOOTPRINT*

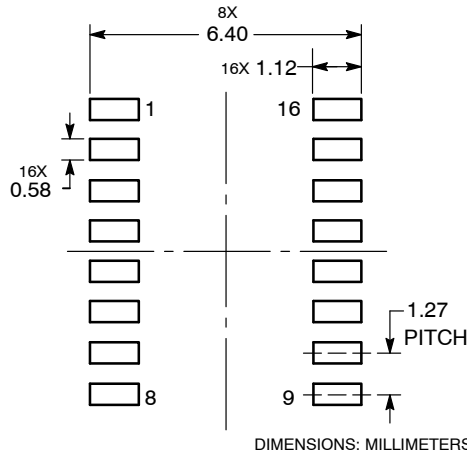

*For additional information on our Pb-Free strategy and soldering details, please download the ON Semiconductor Soldering and Mounting Techniques Reference Manual, SOLDERRM/D.

ON Semiconductor and are registered trademarks of Semiconductor Components Industries, LLC (SCILLC). SCILLC reserves the right to make changes without further notice to any products herein. SCILLC makes no warranty, representation or guarantee regarding the suitability of its products for any particular purpose, nor does SCILLC assume any liability arising out of the application or use of any product or circuit, and specifically disclaims any and all liability, including without limitation special, consequential or incidental damages. "Typical" parameters which may be provided in SCILLC data sheets and/or specifications can and do vary in different applications and actual performance may vary over time. All operating parameters, including "Typicals" must be validated for each customer application by customer's technical experts. SCILLC does not convey any license under its patent rights nor the rights of others. SCILLC products are not designed, intended, or authorized for use as components in systems intended for surgical implant into the body, or other applications intended to support or sustain life, or for any other application in which the failure of the SCILLC product could create a situation where personal injury or death may occur. Should Buyer purchase or use SCILLC products for any such unintended or unauthorized application, Buyer shall indemnify and hold SCILLC and its officers, employees, subsidiaries, affiliates, and distributors harmless against all claims, costs, damages, and expenses, and reasonable attorney fees arising out of, directly or indirectly, any claim of personal injury or death associated with such unintended or unauthorized use, even if such claim alleges that SCILLC was negligent regarding the design or manufacture of the part. SCILLC is an Equal Opportunity/Affirmative Action Employer. This literature is subject to all applicable copyright laws and is not for resale in any manner.

PUBLICATION ORDERING INFORMATION



LITERATURE FULFILLMENT:
Literature Distribution Center for ON Semiconductor
P.O. Box 5163, Denver, Colorado 80217 USA
Phone: 303-675-2175 or 800-344-3860 Toll Free USA/Canada
Fax: 303-675-2176 or 800-344-3867 Toll Free USA/Canada
Email: orderlit@onsemi.com

N. American Technical Support: 800-282-9855 Toll Free USA/Canada
Europe, Middle East and Africa Technical Support: Phone: 421 33 790 2910
Japan Customer Focus Center Phone: 81-3-5773-3850

ON Semiconductor Website: www.onsemi.com
Order Literature: <http://www.onsemi.com/orderlit>
For additional information, please contact your local Sales Representative

Looking for pricing, stock, or lifecycle information?

Click below to explore more details on WIN SOURCE:

-  [View NCS6433DTBR2G on WIN SOURCE](#)
-  [ON Semiconductor Information](#)

Optimize Your Supply Chain with WIN SOURCE Solutions

-  Global Sourcing Solution
-  Obsolete Management
-  Cost Control Management
-  Shortage Management
-  Alternative Solution
-  Excess Inventory Management