



# THE DATASHEET OF TLE4946H



Data Sheet, V 1.1, October 2005

# TLE4946H TLE4946-1L

High Precision Bipolar Hall-Effect Latch



Sensors



Never stop thinking

**Edition 2005-10**

**Published by Infineon Technologies AG,  
St.-Martin-Strasse 53,  
81669 München, Germany**

**© Infineon Technologies AG 2005.  
All Rights Reserved.**

**Attention please!**

The information given in this document shall in no event be regarded as a guarantee of conditions or characteristics ("Beschaffenheitsgarantie"). With respect to any examples or hints given herein, any typical values stated herein and/or any information regarding the application of the device, Infineon Technologies hereby disclaims any and all warranties and liabilities of any kind, including without limitation warranties of non-infringement of intellectual property rights of any third party.

**Information**

For further information on technology, delivery terms and conditions and prices please contact your nearest Infineon Technologies Office ([www.infineon.com](http://www.infineon.com)).

**Warnings**

Due to technical requirements components may contain dangerous substances. For information on the types in question please contact your nearest Infineon Technologies Office.

Infineon Technologies Components may only be used in life-support devices or systems with the express written approval of Infineon Technologies, if a failure of such components can reasonably be expected to cause the failure of that life-support device or system, or to affect the safety or effectiveness of that device or system. Life support devices or systems are intended to be implanted in the human body, or to support and/or maintain and sustain and/or protect human life. If they fail, it is reasonable to assume that the health of the user or other persons may be endangered.

<b>TLE4946H</b>	
<b>TLE4946-1L</b>	
<b>Revision History:</b>	<b>2005-10</b> <span style="float: right;">V 1.1</span>
Previous Version:	1.0
Page	Subjects (major changes since last revision)
<b>6</b>	<b>Figure 1</b> Correction of dimensions for package PG-SSO-3-2
<b>14</b>	<b>Figure 6</b> Correction of dimensions
<b>16</b>	<b>Figure 10</b> Correction of dimensions
<b>11</b>	<b>Table 7</b> New entry: Magnetic Offset for TLE4946-1L

**We Listen to Your Comments**

Any information within this document that you feel is wrong, unclear or missing at all?  
Your feedback will help us to continuously improve the quality of this document.

Please send your proposal (including a reference to this document) to:

[feedback.sensors@infineon.com](mailto:feedback.sensors@infineon.com)



<b>1</b>	<b>Overview</b> .....	5
1.1	Features .....	5
1.2	Functional Description .....	5
1.3	Pin Configuration (top view) .....	6
<b>2</b>	<b>General</b> .....	7
2.1	Block Diagram .....	7
2.2	Circuit Description .....	7
<b>3</b>	<b>Maximum Ratings</b> .....	8
<b>4</b>	<b>Operating Range</b> .....	9
<b>5</b>	<b>Electrical and Magnetic Parameters</b> .....	10
	Field Direction Definion .....	12
<b>6</b>	<b>Timing Diagram</b> .....	12
<b>7</b>	<b>Package Information</b> .....	13
7.1	Package Marking .....	13
7.2	Distance between Chip and Package Surface .....	14
7.3	Package Outlines .....	15
	PCB Footprint for SC59 .....	15



## High Precision Bipolar Hall-Effect Latch

TLE4946H  
TLE4946-1L

### 1 Overview

#### 1.1 Features

- 2.7 V to 24 V supply voltage operation
- Operation from unregulated power supply
- High sensitivity and high stability of the magnetic switching points
- High resistance to mechanical stress by Active Error Compensation
- Reverse battery protection (– 18 V)
- Superior temperature stability
- Peak temperatures up to 195°C without damage
- Low jitter (typ. 1  $\mu$ s)
- High ESD performance ( $\pm$  6 kV HBM)
- Digital output signal
- SMD package SC59 (SOT23 compatible) - (TLE4946H)
- Leaded package PG-SSO-3-2 - (TLE4946-1L)

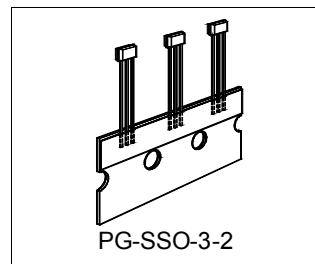
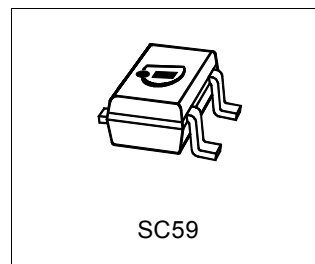

#### 1.2 Functional Description

The TLE4946H and the TLE4946-1L are integrated circuit Hall-effect sensors designed specifically for highly accurate applications.

Precise magnetic switching points and high temperature stability are achieved by active compensation circuits and chopper techniques on chip.

Type	Package
TLE4946H	SC59
TLE4946-1L	PG-SSO-3-2

### 1.3 Pin Configuration (top view)

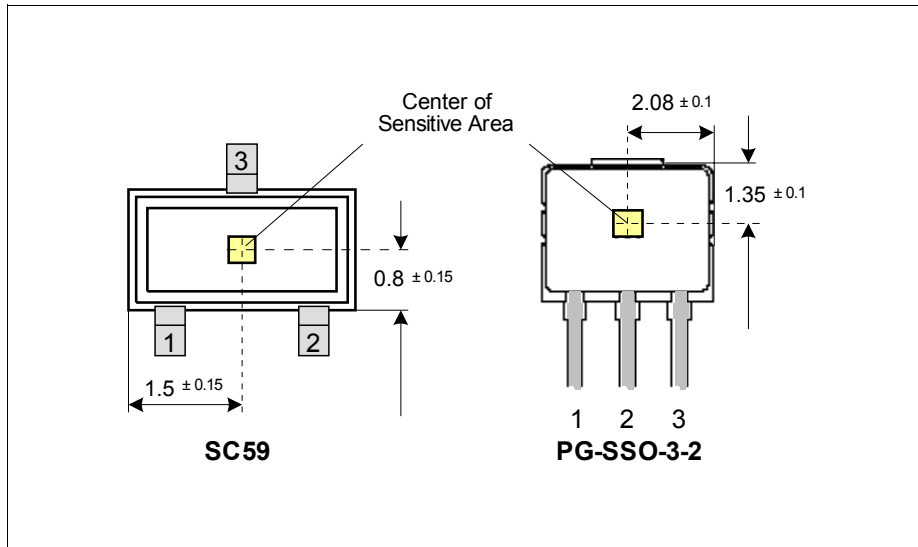

Figure 1 Pin Definition and Center of Sensitive Area

Table 1 Pin Definitions and Functions SC59

Pin No.	Symbol	Function
1	$V_S$	Supply voltage
2	Q	Output
3	GND	Ground

Table 2 Pin Definitions and Functions PG-SSO-3-2

Pin No.	Symbol	Function
1	$V_S$	Supply voltage
2	GND	Ground
3	Q	Output

## 2 General

### 2.1 Block Diagram

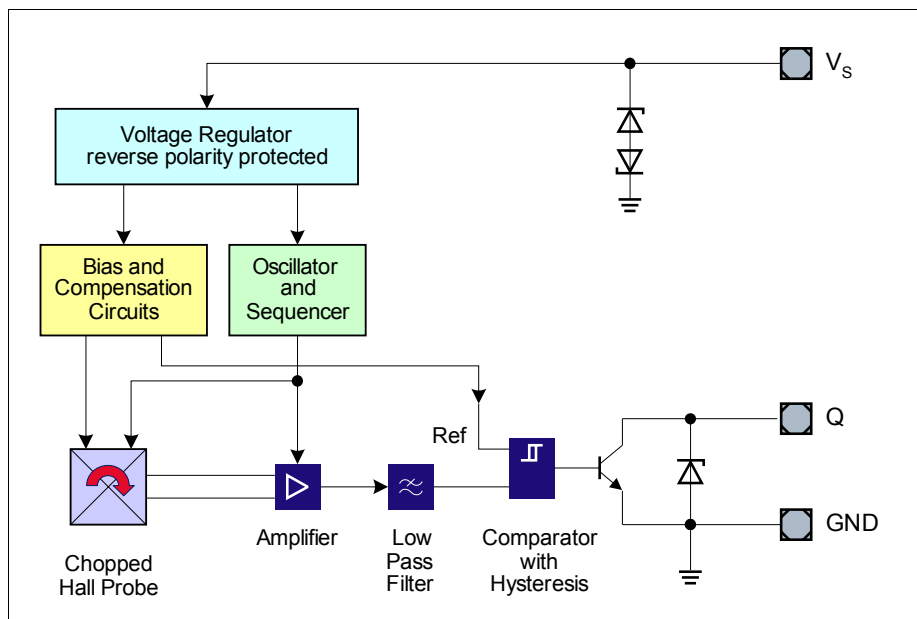

Figure 2 Block Diagram

### 2.2 Circuit Description

The chopped Hall IC Switch comprises a Hall probe, bias generator, compensation circuits, oscillator, and output transistor.

The bias generator provides currents for the Hall probe and the active circuits. Compensation circuits stabilize the temperature behavior and reduce technology variations.

The Active Error Compensation rejects offsets in signal stages and the influence of mechanical stress to the Hall probe caused by molding and soldering processes and other thermal stresses in the package.

This chopper technique together with the threshold generator and the comparator ensure high accurate magnetic switching points.

Maximum Ratings

### 3 Maximum Ratings

**Table 3 Absolute Maximum Ratings**  
 $T_j = -40^\circ\text{C}$  to  $150^\circ\text{C}$

Parameter	Symbol	Limit Values		Unit	Conditions
		min.	max.		
Supply voltage	$V_S$	- 18 - 18 - 18	18 24 26	V	for 1 h, $R_s \geq 200 \Omega$ for 5 min, $R_s \geq 200 \Omega$
Supply current through protection device	$I_S$	- 50	+ 50	mA	
Output voltage	$V_Q$	- 0.7 - 0.7	18 26	V	for 5 min @ 1.2 k $\Omega$ pull up
Continuous output current	$I_Q$	- 50	+ 50	mA	
Junction temperature	$T_j$	- - - -	155 165 175 195	$^\circ\text{C}$	for 2000 h (not additive) for 1000 h (not additive) for 168 h (not additive) for 3 x 1 h (additive)
Storage temperature	$T_S$	- 40	150	$^\circ\text{C}$	
Magnetic flux density	B	-	unlimited	mT	

*Note: Stresses above those listed here may cause permanent damage to the device.  
Exposure to absolute maximum rating conditions for extended periods may affect device reliability.*

**Table 4 ESD Protection <sup>1)</sup>**

Parameter	Symbol	Limit Values		Unit	Notes
		min.	max.		
ESD voltage	$V_{\text{ESD}}$	-	$\pm 6$	kV	HBM, $R = 1.5 \text{ k}\Omega$ , $C = 100 \text{ pF}$ $T_A = 25^\circ\text{C}$

<sup>1)</sup> Human Body Model (HBM) tests according to: EOS/ESD Association Standard S5.1-1993 and Mil. Std. 883D method 3015.7

## 4 Operating Range

Table 5 Operating Range

Parameter	Symbol	Limit Values			Unit	Conditions
		min.	typ.	max.		
Supply voltage	$V_S$	2.7	–	18	V	
Output voltage	$V_Q$	– 0.7	–	18	V	
Junction temperature	$T_j$	– 40	–	150	°C	
Output current	$I_Q$	0	–	20	mA	

## 5 Electrical and Magnetic Parameters

**Table 6 Electrical Characteristics <sup>1)</sup>.**

Parameter	Symbol	Limit Values			Unit	Conditions
		min.	typ.	max.		
Supply current	$I_S$	2	4	6	mA	$V_S = 2.7 \text{ V} \dots 18 \text{ V}$
Reverse current	$I_{SR}$	0	0.2	1	mA	$V_S = -18 \text{ V}$
Output saturation voltage	$V_{QSAT}$	–	0.3	0.6	V	$I_Q = 20 \text{ mA}$
Output leakage current	$I_{QLEAK}$	–	0.05	10	$\mu\text{A}$	for $V_Q = 18 \text{ V}$
Output fall time	$t_f$	–	0.02	1	$\mu\text{s}$	$R_L = 1.2 \text{ k}\Omega$ ; $C_L = 50 \text{ pF}$ see: <a href="#">Figure 3 “Timing Definition” on Page 12</a>
Output rise time	$t_r$	–	0.4	1	$\mu\text{s}$	
Chopper frequency	$f_{OSC}$	–	320	–	kHz	
Switching frequency	$f_{SW}$	0	–	15 <sup>2)</sup>	kHz	
Delay time <sup>3)</sup>	$t_d$	–	13	–	$\mu\text{s}$	
Output jitter <sup>4)</sup>	$t_{QJ}$	–	1	–	$\mu\text{s}_{RMS}$	Typical value for square wave signal 1 kHz
Power-on time <sup>5)</sup>	$t_{PON}$	–	13	–	$\mu\text{s}$	$V_S \geq 2.7 \text{ V}$
Thermal resistance <sup>6)</sup>	$R_{thJA}$	–	100	–	K/W	SC59
		–	–	190		PG-SSO-3-2

1) over operating range, unless otherwise specified. Typical values correspond to  $V_S = 12 \text{ V}$  and  $T_A = 25^\circ\text{C}$

2) To operate the sensor at the max. switching frequency, the value of the magnetic signal amplitude must be 1.4 times higher than for static fields.

This is due to the -3 dB corner frequency of the low pass filter in the signal path.

3) Systematic delay between magnetic threshold reached and output switching

4) Jitter is the unpredictable deviation of the output switching delay

5) Time from applying  $V_S \geq 2.7 \text{ V}$  to the sensor until the output state is valid

6) Thermal resistance from junction to ambient

### Calculation of the ambient temperature (SC59 example)

e.g. for  $V_S = 12.0 \text{ V}$ ,  $I_{Styp} = 4 \text{ mA}$ ,  $V_{QSATtyp} = 0.3 \text{ V}$  and  $I_Q = 20 \text{ mA}$  :

Power Dissipation:  $P_{DIS} = 54.0 \text{ mW}$ .

In  $T_A = T_j - (R_{thJA} \times P_{DIS}) = 175^\circ\text{C} - (100 \text{ K/W} \times 0.054 \text{ W})$

Resulting max. ambient temperature:  $T_A = 169.6^\circ\text{C}$

**Electrical and Magnetic Parameters**
**Table 7 Magnetic Characteristics TLE4946H <sup>1)</sup>**

Parameter	Symbol	$T_j$ [°C]	Limit Values			Unit	Notes
			min.	typ.	max.		
Operate point	$B_{OP}$	- 40	11.8	15.8	19.2	mT	TLE4946H
		25	11.0	14.0	17.0		
		150	6.1	9.6	13.7		
		- 40	11.3	15.4	19.5		TLE4946-1L
		25	11.0	15.0	19.0		
		150	10.5	14.3	18.1		
Release point	$B_{RP}$	- 40	- 19.2	- 15.8	- 11.8	mT	TLE4946H
		25	- 17.0	- 14.0	- 11.0		
		150	- 13.7	- 9.6	- 6.1		
		- 40	- 19.5	- 15.4	- 11.3		TLE4946-1L
		25	- 19.0	- 15.0	- 11.0		
		150	- 18.1	- 14.3	- 10.5		
Hysteresis	$B_{HYS}$	- 40	-	-	-	mT	TLE4946H
		25	22.0	28.0	34.0		
		150	-	-	-		
		- 40	-	-	-		TLE4946-1L
		25	22.0	30.0	38.0		
		150	-	-	-		
Magnetic Offset	$B_{OFF}$	- 40	-	-	-	mT	TLE4946H <sup>2)</sup>
		25	- 3.0	-	3.0		
		150	-	-	-		
		- 40	-	-	-		TLE4946-1L <sup>2)</sup>
		25	- 2.0	-	2.0		
		150	-	-	-		
Temperature compensation of magn. thresholds	TC	-	-	- 2000	-	ppm/°C	TLE4946H
		-	-	- 350	-		TLE4946-1L
Repeatability of magnetic thresholds <sup>3)</sup>	$B_{REP}$		-	20	-	$\mu T_{RMS}$	Typ. value for $\Delta B / \Delta t > 12$ mT/ms

1) over operating range, unless otherwise specified. Typical values correspond to  $V_S = 12$  V.

2)  $B_{OFF} = (B_{OP} + B_{RP}) / 2$

3)  $B_{REP}$  is equivalent to the noise constant

*Note: Typical characteristics specify mean values expected over the production spread.*

**Field Direction Definition**

Positive magnetic fields related with south pole of magnet to the branded side of package.

**6 Timing Diagram**

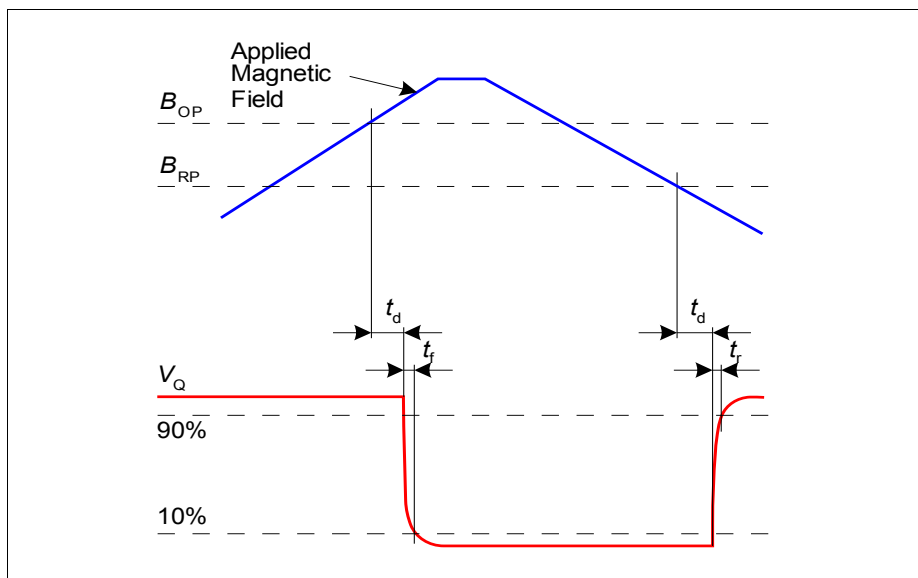

**Figure 3 Timing Definition**

## 7 Package Information

### 7.1 Package Marking

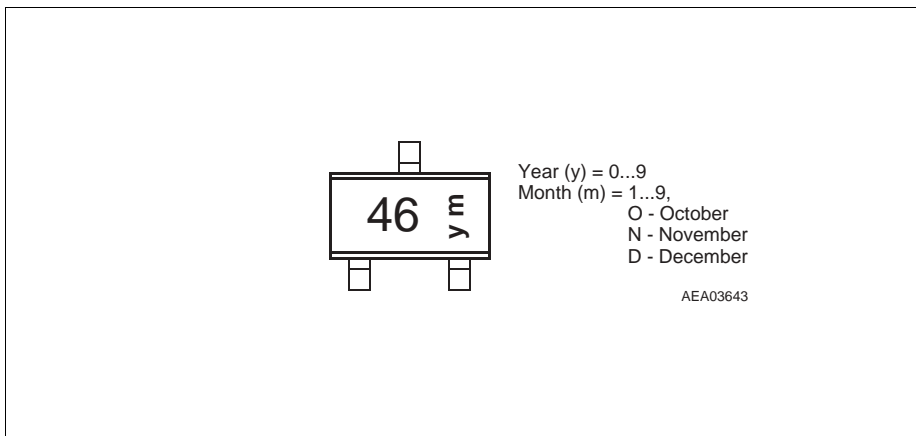

Figure 4 Marking TLE4946H

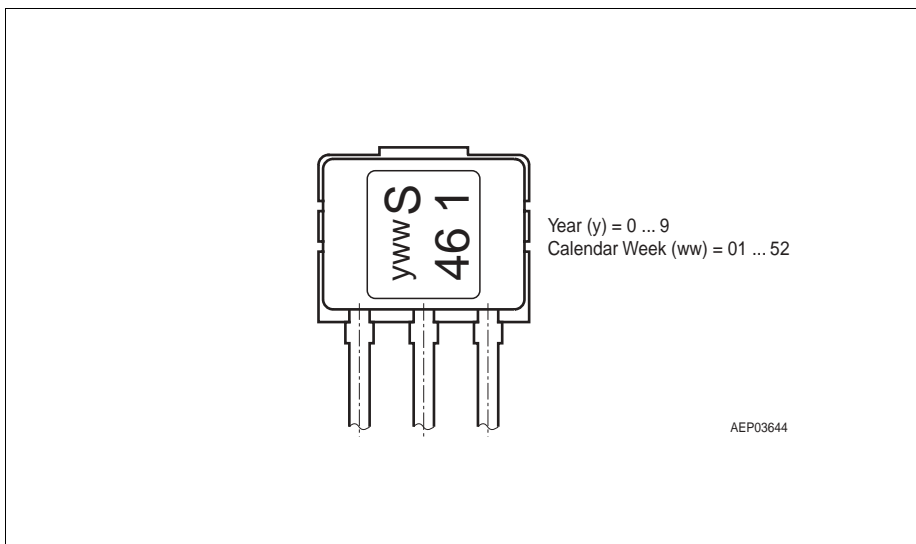

Figure 5 Marking TLE4946-1L

7.2 Distance between Chip and Package Surface

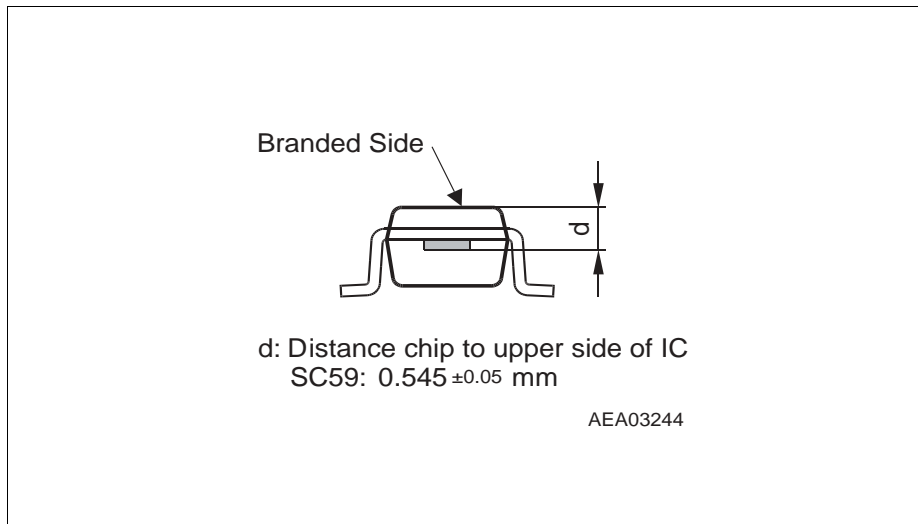

Figure 6 Distance Chip SC59 to Upper Side of IC

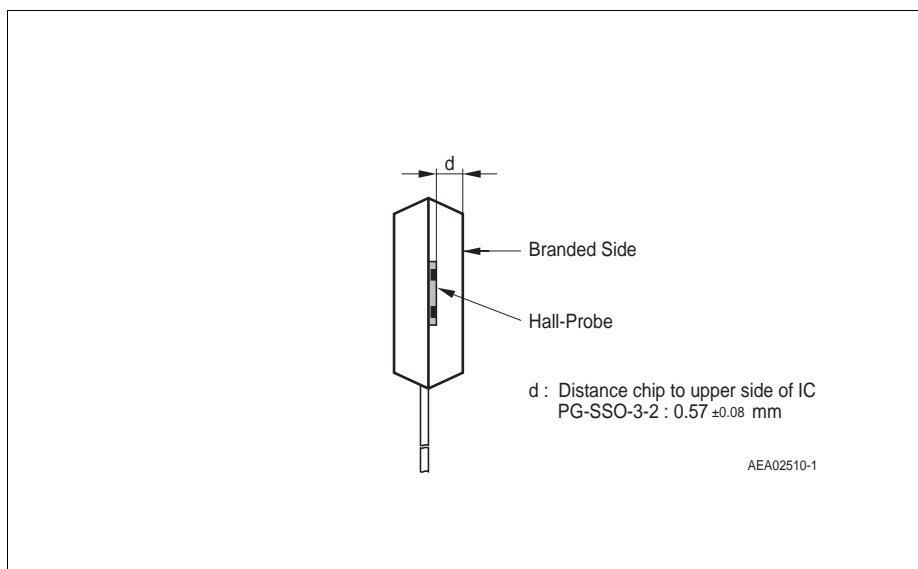

Figure 7 Distance Chip PG-SSO-3-2 to Upper Side of IC

7.3 Package Outlines

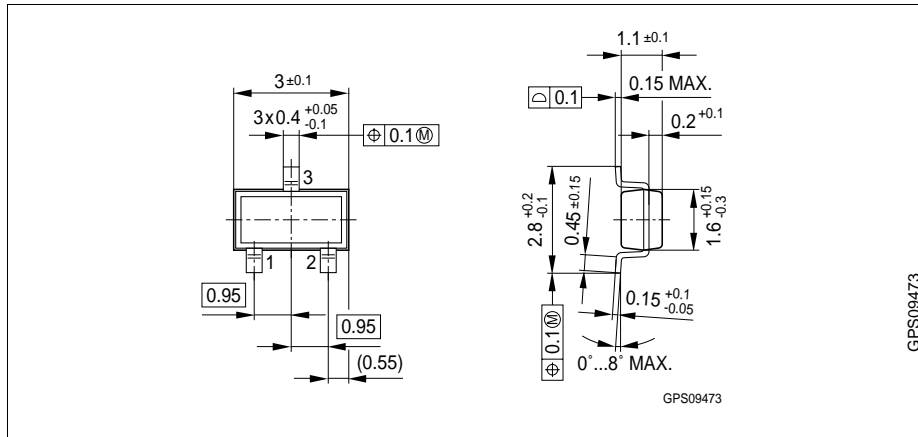

Figure 8 SC59

PCB Footprint for SC59

The following picture shows a recommendation for the PCB layout.

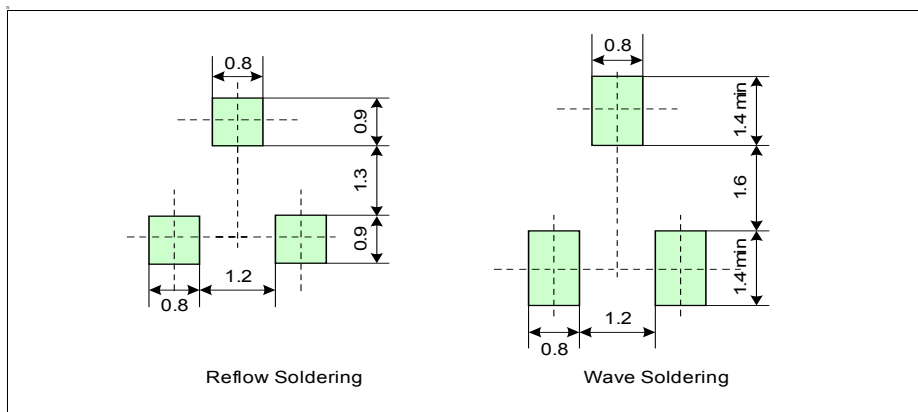

Figure 9 Footprint SC59 (SOT23 compatible)

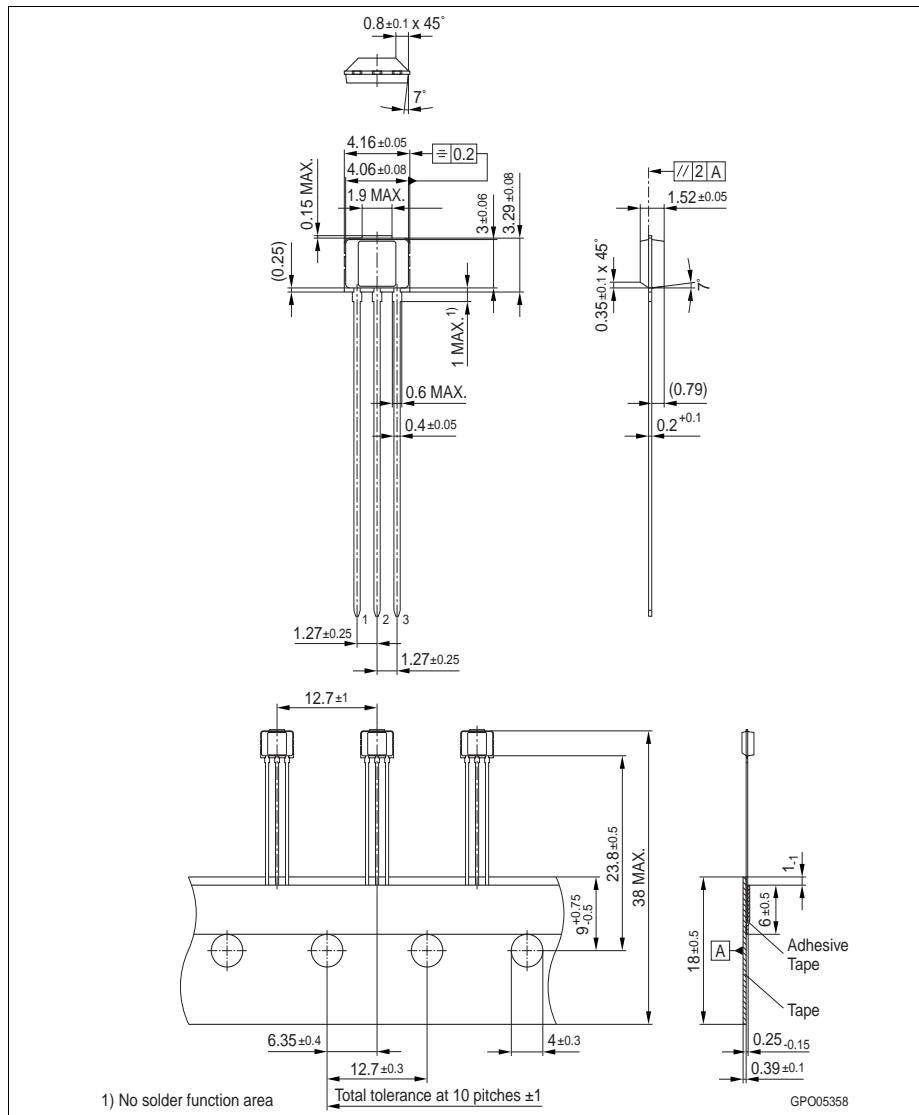

Figure 10 PG-SSO-3-2

Note: You can find all of our packages, sorts of packing and others in our Infineon Internet Page "Products": <http://www.infineon.com/products>.

Dimensions in mm



**TLE4946H**  
**TLE4946-1L**

---

**Notes**



**TLE4946H**  
**TLE4946-1L**

---

**Notes**



**TLE4946H**  
**TLE4946-1L**

---

**Notes**





[www.infineon.com](http://www.infineon.com)

Published by Infineon Technologies AG

## Looking for pricing, stock, or lifecycle information?

Click below to explore more details on WIN SOURCE:

-  [View TLE4946H on WIN SOURCE](#)
-  [Infineon Technologies Information](#)

## Optimize Your Supply Chain with WIN SOURCE Solutions

-  Global Sourcing Solution
-  Obsolete Management
-  Cost Control Management
-  Shortage Management
-  Alternative Solution
-  Excess Inventory Management