



# THE DATASHEET OF TSV991ILT



## Rail-to-rail input/output 20 MHz GBP operational amplifiers

Pin connections  
(top view)

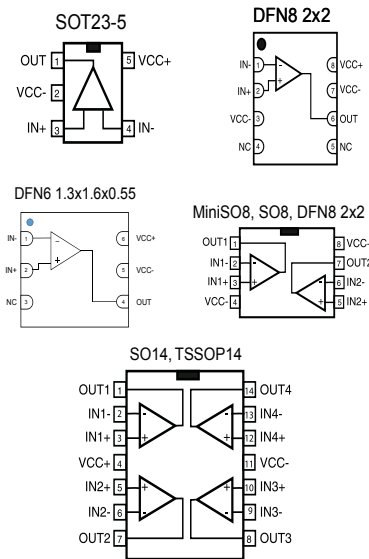

### Features

- Low input offset voltage: 1.5 mV max. (A grade)
- Rail-to-rail input and output
- Wide bandwidth 20 MHz
- Stable for gain  $\geq 4$  or  $\leq -3$
- Low power consumption: 820  $\mu$ A typ.
- High output current: 35 mA
- Operating from 2.5 V to 5.5 V
- Low input bias current, 1 pA typ.
- ESD internal protection  $\geq 5$  kV

### Applications

- Battery-powered applications
- Portable devices
- Signal conditioning and active filtering
- Medical instrumentation
- Automotive applications

### Description

The TSV99x and TSV99xA family of single, dual, and quad operational amplifiers offers low voltage operation and rail-to-rail input and output. These devices feature an excellent speed/power consumption ratio, offering a 20 MHz gain-bandwidth, stable for gains above 4 (100 pF capacitive load), while consuming only 1.1 mA maximum at 5 V. They also feature an ultra-low input bias current. These characteristics make the TSV99x family ideal for sensor interfaces, battery-supplied and portable applications, as well as active filtering. These characteristics make the TSV99x, TSV99xA family ideal for sensor interfaces, battery-supplied and portable applications, as well as active filtering.

#### Product status link

[TSV991](#), [TSV992](#), [TSV994](#), [TSV991A](#),  
[TSV992A](#), [TSV994A](#)

#### Related products

See [TSV911](#),  
[TSV912](#), [TSV914](#),  
[TSV911A](#),  
[TSV912A](#),  
[TSV914A](#)

For unity-gain  
stable amplifiers

# 1 Absolute maximum ratings and operating conditions

**Table 1. Absolute maximum ratings (AMR)**

Symbol	Parameter		Value	Unit
$V_{CC}$	Supply voltage <sup>(1)</sup>		6	V
$V_{id}$	Differential input voltage <sup>(2)</sup>		$\pm V_{CC}$	
$V_{in}$	Input voltage <sup>(3)</sup>		$(V_{CC-}) - 0.2$ to $(V_{CC+}) + 0.2$	
$I_{in}$	Input current <sup>(4)</sup>		10	mA
$T_{stg}$	Storage temperature		-65 to 150	°C
$T_j$	Maximum junction temperature		150	
$R_{thja}$	Thermal resistance junction to ambient <sup>(5) (6)</sup>	DFN8 2x2	57	°C/W
		DFN6 1.3x1.6x0.55	230	
		SOT23-5	250	
		SO8	125	
		MiniSO8	190	
		SO14	103	
		TSSOP14	100	
$R_{thjc}$	Thermal resistance junction to case	SOT23-5	81	°C/W
		SO8	40	
		MiniSO8	39	
		SO14	31	
		TSSOP14	32	
ESD	HBM: human body model <sup>(7)</sup>		5	kV
	MM: machine model <sup>(8)</sup>		400	V
	CDM: charged device model <sup>(9)</sup>	SOT23-5, SO8, MiniSO8, DFN8 2x2	1500	
		DFN6 1.3x1.6x0.55	TBD	
		TSSOP14	750	
SO14		500		
	Latch-up immunity		200	mA

1. Value is with respect to the  $V_{CC}$ -pin.
2. Differential voltages are the non-inverting input terminal with respect to the inverting input terminal.
3.  $V_{CC} - V_{IN}$  must not exceed 6 V.
4. Input current must be limited by a resistor in series with the inputs.
5. Short-circuits can cause excessive heating and destructive dissipation.
6.  $R_{th}$  are typical values.
7. Human body model: 100 pF discharged through a 1.5 k $\Omega$  resistor between two pins of the device, done for all couples of pin combinations with other pins floating.
8. Machine model: 200 pF charged to the specified voltage, then discharged directly between two pins of the device with no external series resistor (internal resistor < 5  $\Omega$ ), done for all couples of pin combinations with other pins floating.
9. Charged device model: all pins plus packages are charged together to the specified voltage and then discharged directly to the ground.

**Table 2. Operating conditions**

Symbol	Parameter	Value	Unit
$V_{CC}$	Supply voltage	2.5 to 5.5	V
$V_{icm}$	Common mode input voltage range	$(V_{CC-}) - 0.1$ to $(V_{CC+}) + 0.1$	
$T_{op}$	Operating free air temperature range	-40 to 125	°C

## 2 Electrical characteristics

*Note:* In the electrical characteristic tables below, all parameter limits at temperatures other than 25 °C are guaranteed by correlation.

**Table 3. Electrical characteristics at  $V_{CC+} = 2.5\text{ V}$ ,  $V_{CC-} = 0\text{ V}$ ,  $V_{icm} = V_{CC}/2$ , with  $R_L$  connected to  $V_{CC}/2$ , full temperature range (unless otherwise specified)**

Symbol	Parameter	Conditions	Min.	Typ.	Max.	Unit
<b>DC performance</b>						
$V_{io}$	Offset voltage, TSV99x	$T_{op} = 25\text{ °C}$		0.1	4.5	mV
		$T_{min} < T_{op} < T_{max}$			7.5	
	Offset voltage, TSV99xA	$T_{op} = 25\text{ °C}$			1.5	
		$T_{min} < T_{op} < T_{max}$			3	
$\Delta V_{io}/\Delta T$	Input offset voltage drift			2		$\mu\text{V}/\text{°C}$
$I_{io}$	Input offset current, $V_{out} = V_{CC}/2$ <sup>(1)</sup>	$T_{op} = 25\text{ °C}$		1	10	pA
		$T_{min} < T_{op} < T_{max}$			100	
$I_{ib}$	Input bias current, $V_{out} = V_{CC}/2$ <small>Section 2 (1)</small>	$T_{op} = 25\text{ °C}$		1	10	pA
		$T_{min} < T_{op} < T_{max}$			100	
CMR	Common mode rejection ratio, $20 \log(\Delta V_{ic}/\Delta V_{io})$	$0\text{ V to } 2.5\text{ V}$ , $V_{out} = 1.25\text{ V}$ , $T_{op} = 25\text{ °C}$	58	75		dB
		$T_{min} < T_{op} < T_{max}$	53			
$A_{vd}$	Large signal voltage gain	$R_L = 10\text{ k}\Omega$ , $V_{out} = 0.5\text{ V to } 2\text{ V}$ , $T_{op} = 25\text{ °C}$	80	89		dB
		$T_{min} < T_{op} < T_{max}$	75			
$V_{CC} - V_{OH}$	High-level output voltage	$R_L = 10\text{ k}\Omega$ , $T_{min} < T_{op} < T_{max}$		15	40	mV
		$R_L = 600\ \Omega$ , $T_{min} < T_{op} < T_{max}$		45	150	
$V_{OL}$	Low-level output voltage	$R_L = 10\text{ k}\Omega$ , $T_{min} < T_{op} < T_{max}$		15	40	mV
		$R_L = 600\ \Omega$ , $T_{min} < T_{op} < T_{max}$		45	150	
$I_{out}$	$I_{sink}$	$V_o = 2.5\text{ V}$ , $T_{op} = 25\text{ °C}$	18	32		mA
		$T_{min} < T_{op} < T_{max}$	16			
	$I_{source}$	$V_o = 0\text{ V}$ , $T_{op} = 25\text{ °C}$	18	35		
		$T_{min} < T_{op} < T_{max}$	16			
$I_{CC}$	Supply current (per channel)	No load, $V_{out} = V_{CC}/2$ , $T_{min} < T_{op} < T_{max}$		0.78	1.1	
<b>AC performance</b>						
GBP	Gain bandwidth product	$R_L = 2\text{ k}\Omega$ , $C_L = 100\text{ pF}$ , $f = 100\text{ kHz}$ , $T_{op} = 25\text{ °C}$		20		MHz
Gain	Minimum gain for stability	Phase margin = 45°, $R_f = 10\text{ k}\Omega$ , $R_L = 2\text{ k}\Omega$ , $C_L = 100\text{ pF}$ , $T_{op} = 25\text{ °C}$ , positive gain configuration		4		V/V

Symbol	Parameter	Conditions	Min.	Typ.	Max.	Unit
Gain	Minimum gain for stability	Phase margin = 45°, $R_f = 10\text{ k}\Omega$ , $R_L = 2\text{ k}\Omega$ , $C_L = 100\text{ pF}$ , $T_{op} = 25\text{ }^\circ\text{C}$ , negative gain configuration		-3		V/V
SR	Slew rate	$R_L = 2\text{ k}\Omega$ , $C_L = 100\text{ pF}$ , $T_{op} = 25\text{ }^\circ\text{C}$		10		V/ $\mu\text{s}$
$e_n$	Equivalent input noise voltage	$f = 10\text{ kHz}$ , $T_{op} = 25\text{ }^\circ\text{C}$		21		nV/ $\sqrt{\text{Hz}}$
THD+N	Total harmonic distortion	$G = -3$ , $f = 1\text{ kHz}$ , $R_L = 2\text{ k}\Omega$ , $B_w = 22\text{ kHz}$ , $V_{icm} = V_{CC}/2$ , $V_{out} = 2\text{ V}_{pp}$ , $T_{op} = 25\text{ }^\circ\text{C}$		0.0025		%

1. Guaranteed by design

**Table 4. Electrical characteristics at  $V_{CC+} = 3.3\text{ V}$ ,  $V_{CC-} = 0\text{ V}$ ,  $V_{icm} = V_{CC}/2$ , with  $R_L$  connected to  $V_{CC}/2$ , full temperature range (unless otherwise specified)**

Symbol	Parameter	Conditions	Min.	Typ.	Max.	Unit
<b>DC performance</b>						
$V_{io}$	Offset voltage, TSV99x	$T_{op} = 25\text{ }^\circ\text{C}$		0.1	4.5	mV
		$T_{min} < T_{op} < T_{max}$			7.5	
	Offset voltage, TSV99xA	$T_{op} = 25\text{ }^\circ\text{C}$			1.5	
		$T_{min} < T_{op} < T_{max}$			3	
$\Delta V_{io}/\Delta T$	Input offset voltage drift			2		$\mu\text{V}/^\circ\text{C}$
$I_{io}$	Input offset current, $V_{out} = V_{CC}/2$ <sup>(1)</sup>	$T_{op} = 25\text{ }^\circ\text{C}$		1	10	pA
		$T_{min} < T_{op} < T_{max}$			100	
$I_{ib}$	Input bias current, $V_{out} = V_{CC}/2$ Section 2 (1)	$T_{op} = 25\text{ }^\circ\text{C}$		1	10	
		$T_{min} < T_{op} < T_{max}$			100	
CMR	Common mode rejection ratio, $20\text{ log}(\Delta V_{ic}/\Delta V_{io})$	$0\text{ V to } 3.3\text{ V}$ , $V_{out} = 1.65\text{ V}$ , $T_{op} = 25\text{ }^\circ\text{C}$	60	78		dB
		$T_{min} < T_{op} < T_{max}$	55			
$A_{vd}$	Large signal voltage gain	$R_L = 10\text{ k}\Omega$ , $V_{out} = 0.5\text{ V to } 2.8\text{ V}$ , $T_{op} = 25\text{ }^\circ\text{C}$	80	89		
		$T_{min} < T_{op} < T_{max}$	75			
$V_{CC} - V_{OH}$	High-level output voltage	$R_L = 10\text{ k}\Omega$ , $T_{min} < T_{op} < T_{max}$		15	40	mV
		$R_L = 600\text{ }\Omega$ , $T_{min} < T_{op} < T_{max}$		45	150	
$V_{OL}$	Low-level output voltage	$R_L = 10\text{ k}\Omega$ , $T_{min} < T_{op} < T_{max}$		15	40	
		$R_L = 600\text{ }\Omega$ , $T_{min} < T_{op} < T_{max}$		45	150	
$I_{out}$	$I_{sink}$	$V_o = 3.3\text{ V}$ , $T_{op} = 25\text{ }^\circ\text{C}$	18	32		mA
		$T_{min} < T_{op} < T_{max}$	16			
	$I_{source}$	$V_o = 0\text{ V}$ , $T_{op} = 25\text{ }^\circ\text{C}$	18	35		
		$T_{min} < T_{op} < T_{max}$	16			
$I_{CC}$	Supply current (per channel)	No load, $V_{out} = V_{CC}/2$ , $T_{min} < T_{op} < T_{max}$		0.8	1.1	
<b>AC performance</b>						

Symbol	Parameter	Conditions	Min.	Typ.	Max.	Unit
GBP	Gain bandwidth product	$R_L = 2\text{ k}\Omega$ , $C_L = 100\text{ pF}$ , $f = 100\text{ kHz}$ , $T_{op} = 25\text{ }^\circ\text{C}$		20		MHz
Gain	Minimum gain for stability	Phase margin = $45^\circ$ , $R_f = 10\text{ k}\Omega$ , $R_L = 2\text{ k}\Omega$ , $C_L = 100\text{ pF}$ , $T_{op} = 25\text{ }^\circ\text{C}$ , positive gain configuration		4		V/V
		Phase margin = $45^\circ$ , $R_f = 10\text{ k}\Omega$ , $R_L = 2\text{ k}\Omega$ , $C_L = 100\text{ pF}$ , $T_{op} = 25\text{ }^\circ\text{C}$ , negative gain configuration		-3		
SR	Slew rate	$R_L = 2\text{ k}\Omega$ , $C_L = 100\text{ pF}$ , $f = 100\text{ kHz}$ , $T_{op} = 25\text{ }^\circ\text{C}$		10		V/ $\mu\text{s}$
$e_n$	Equivalent input noise voltage	$f = 10\text{ kHz}$ , $T_{op} = 25\text{ }^\circ\text{C}$		21		nV/ $\sqrt{\text{Hz}}$
THD+N	Total harmonic distortion	$G = -3$ , $f = 1\text{ kHz}$ , $R_L = 2\text{ k}\Omega$ , $B_w = 22\text{ kHz}$ , $V_{icm} = V_{CC}/2$ , $V_{out} = 2.8\text{ V}_{pp}$ , $T_{op} = 25\text{ }^\circ\text{C}$		0.0018		%

1. Guaranteed by design.

**Table 5. Electrical characteristics at  $V_{CC+} = 5\text{ V}$ ,  $V_{CC-} = 0\text{ V}$ ,  $V_{icm} = V_{CC}/2$ , with  $R_L$  connected to  $V_{CC}/2$ , full temperature range (unless otherwise specified)**

Symbol	Parameter	Conditions	Min.	Typ.	Max.	Unit
<b>DC performance</b>						
$V_{io}$	Offset voltage, TSV99x	$T_{op} = 25\text{ }^\circ\text{C}$		0.1	4.5	mV
		$T_{min} < T_{op} < T_{max}$			7.5	
	Offset voltage, TSV99xA	$T_{op} = 25\text{ }^\circ\text{C}$			1.5	
		$T_{min} < T_{op} < T_{max}$			3	
$\Delta V_{io}/\Delta T$	Input offset voltage drift			2		$\mu\text{V}/^\circ\text{C}$
$I_{io}$	Input offset current, $V_{out} = V_{CC}/2$ <sup>(1)</sup>	$T_{op} = 25\text{ }^\circ\text{C}$		1	10	pA
		$T_{min} < T_{op} < T_{max}$			100	
$I_{ib}$	Input bias current, $V_{out} = V_{CC}/2$ <small>Section 2 (1)</small>	$T_{op} = 25\text{ }^\circ\text{C}$		1	10	
		$T_{min} < T_{op} < T_{max}$			100	
CMR	Common mode rejection ratio, $20\text{ log}(\Delta V_{ic}/\Delta V_{io})$	0 V to 5 V, $V_{out} = 2.5\text{ V}$ , $T_{op} = 25\text{ }^\circ\text{C}$	62	82		dB
		$T_{min} < T_{op} < T_{max}$	57			
SVR	Supply voltage rejection ratio, $20\text{ log}(\Delta V_{cc}/\Delta V_{io})$	$V_{CC} = 2.5\text{ V to } 5\text{ V}$	70	86		
$A_{vd}$	Large signal voltage gain	$R_L = 10\text{ k}\Omega$ , $V_{out} = 0.5\text{ V to } 4.5\text{ V}$ , $T_{op} = 25\text{ }^\circ\text{C}$	80	91		
		$T_{min} < T_{op} < T_{max}$	75			
$V_{CC} - V_{OH}$	High-level output voltage	$R_L = 10\text{ k}\Omega$ , $T_{min} < T_{op} < T_{max}$		15	40	mV
		$R_L = 600\text{ }\Omega$ , $T_{min} < T_{op} < T_{max}$		45	150	
$V_{OL}$	Low-level output voltage	$R_L = 10\text{ k}\Omega$ , $T_{min} < T_{op} < T_{max}$		15	40	
		$R_L = 600\text{ }\Omega$ , $T_{min} < T_{op} < T_{max}$		45	150	

Symbol	Parameter	Conditions	Min.	Typ.	Max.	Unit
$I_{out}$	$I_{sink}$	$V_o = 5\text{ V}, T_{op} = 25\text{ }^\circ\text{C}$	18	32		mA
		$T_{min} < T_{op} < T_{max}$	16			
	$I_{source}$	$V_o = 0\text{ V}, T_{op} = 25\text{ }^\circ\text{C}$	18	35		
		$T_{min} < T_{op} < T_{max}$	16			
$I_{CC}$	Supply current (per channel)	No load, $V_{out} = 2.5\text{ V}, T_{min} < T_{op} < T_{max}$		0.82	1.1	
<b>AC performance</b>						
GBP	Gain bandwidth product	$R_L = 2\text{ k}\Omega, C_L = 100\text{ pF}, f = 100\text{ kHz}, T_{op} = 25\text{ }^\circ\text{C}$		20		MHz
Gain	Minimum gain for stability	Phase margin = $45^\circ$ , $R_f = 10\text{ k}\Omega$ , $R_L = 2\text{ k}\Omega, C_L = 100\text{ pF}, T_{op} = 25\text{ }^\circ\text{C}$ , positive gain configuration		4		V/V
		Phase margin = $45^\circ$ , $R_f = 10\text{ k}\Omega$ , $R_L = 2\text{ k}\Omega, C_L = 100\text{ pF}, T_{op} = 25\text{ }^\circ\text{C}$ , negative gain configuration		-3		
SR	Slew rate	$R_L = 2\text{ k}\Omega, C_L = 100\text{ pF}, f = 100\text{ kHz}, T_{op} = 25\text{ }^\circ\text{C}$		10		V/ $\mu\text{s}$
$e_n$	Equivalent input noise voltage	$f = 10\text{ kHz}, T_{op} = 25\text{ }^\circ\text{C}$		21		nV/ $\sqrt{\text{Hz}}$
THD+N	Total harmonic distortion	$G = -3, f = 1\text{ kHz}, R_L = 2\text{ k}\Omega, Bw = 22\text{ kHz}, V_{icm} = V_{CC}/2, V_{out} = 4.4\text{ V}_{pp}, T_{op} = 25\text{ }^\circ\text{C}$		0.0014		%

1. Guaranteed by design.

### 3 Electrical characteristic curves

Figure 1. Input offset voltage distribution at T = 25 °C

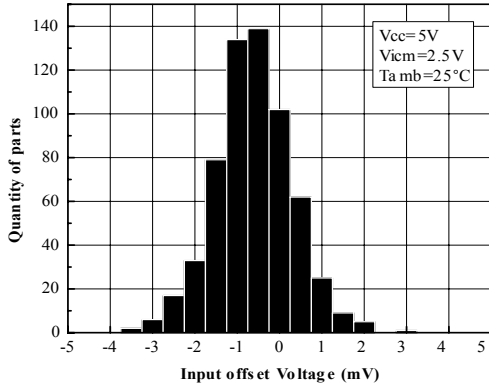

Figure 2. Input offset voltage distribution at T = 125 °C

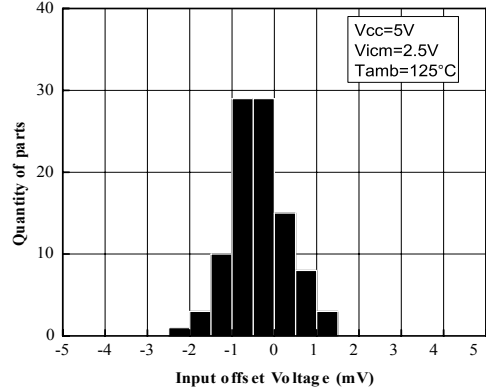

Figure 3. Supply current vs. input common-mode voltage at V<sub>CC</sub> = 2.5 V

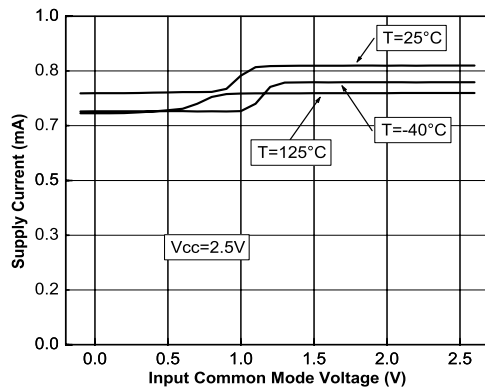

Figure 4. Supply current vs. input common-mode voltage at V<sub>CC</sub> = 5 V

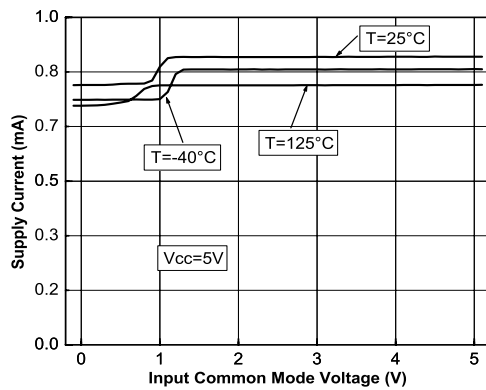

Figure 5. Output current vs. output voltage at V<sub>CC</sub> = 2.5 V

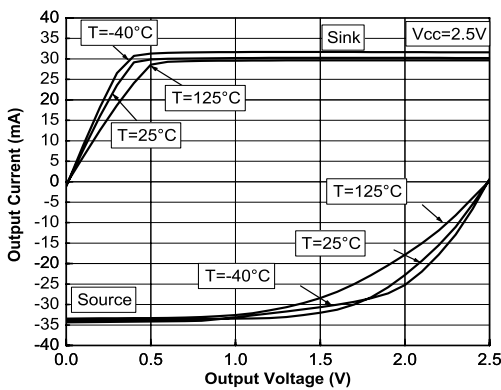
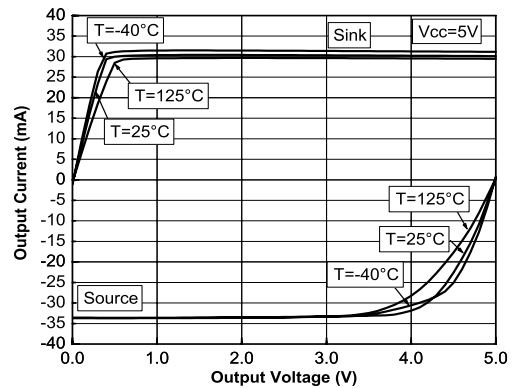
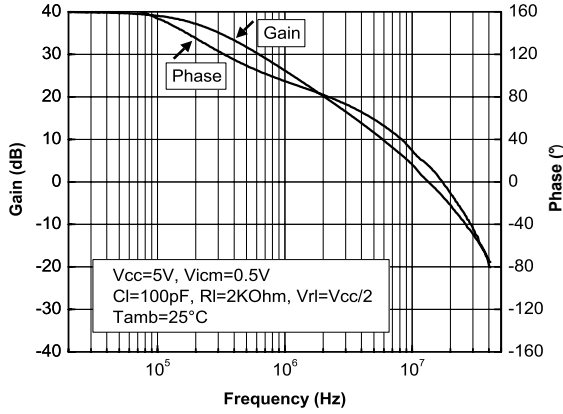

Figure 6. Output current vs. output voltage at V<sub>CC</sub> = 5 V



**Figure 7. Voltage gain and phase vs. frequency at  $V_{CC} = 5$  V and  $V_{icm} = 0.5$  V**



**Figure 8. Voltage gain and phase vs. frequency at  $V_{CC} = 5$  V and  $V_{icm} = 2.5$  V**

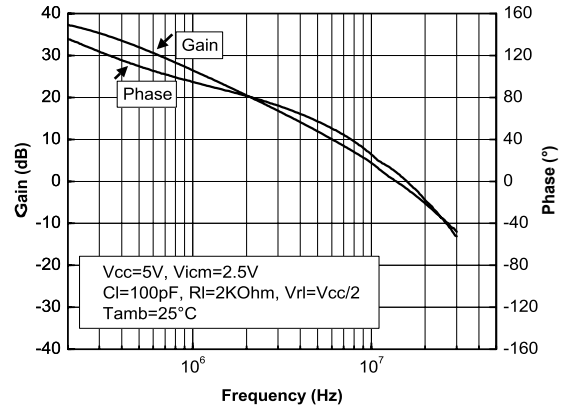

**Figure 9. Positive slew rate**

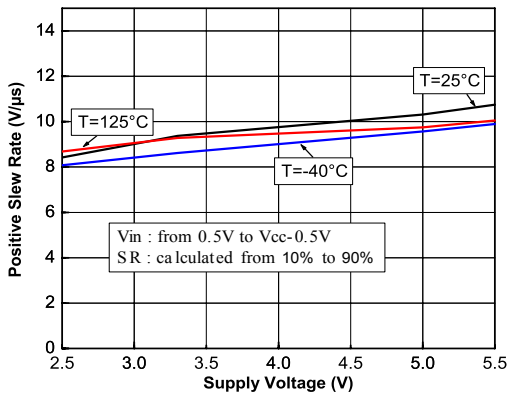

**Figure 10. Negative slew rate**

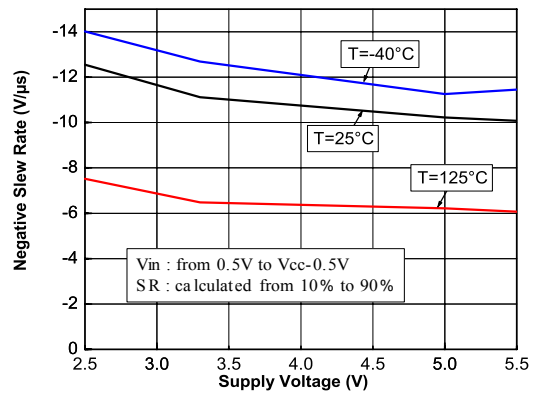

**Figure 11. Distortion + noise vs. frequency**

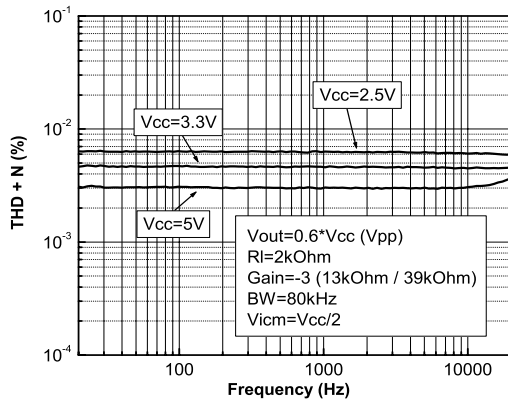

**Figure 12. Distortion + noise vs. output voltage**

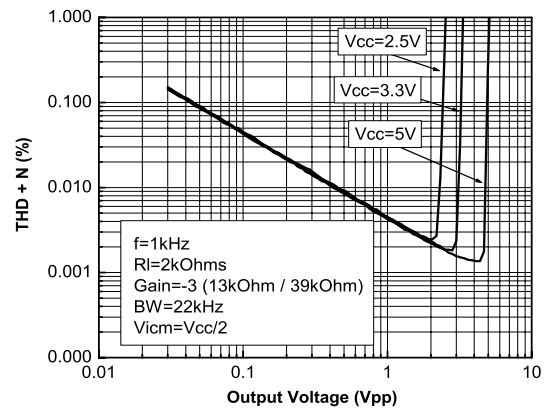

Figure 13. Noise vs. frequency

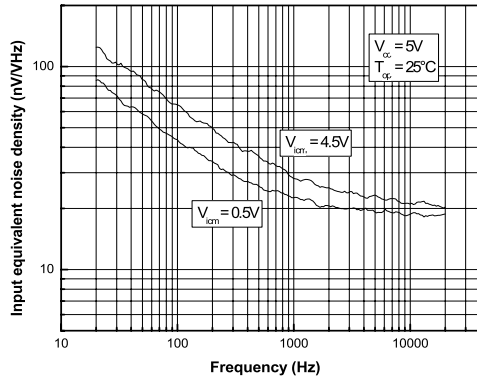
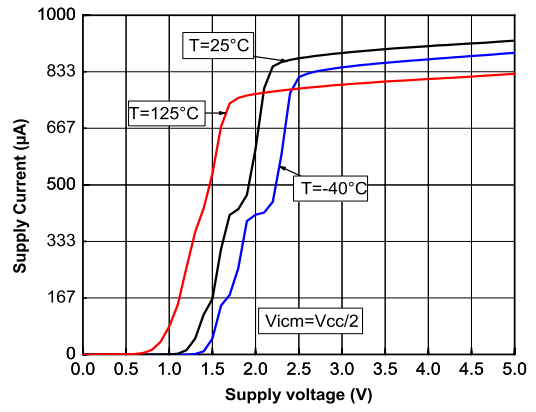

Figure 14. Supply current vs. supply voltage



## 4 Application information

### 4.1 Driving resistive and capacitive loads

These products are low-voltage, low-power operational amplifiers optimized to drive rather large resistive loads above 2 k $\Omega$ .

The TSV99x products are not unity gain stable. To ensure proper stability they must be used in a gain configuration, with a minimum gain of -3 or 4.

However, they can be used in a “*follower*” configuration by adding a small, in-series resistor at the output, which drastically improves the stability of the device (Figure 15. [In-series resistor vs. capacitive load when TSV99x is used in follower configuration](#) shows the recommended in-series resistor values). Once the in-series resistor value has been selected, the stability of the circuit should be tested on the bench and simulated with the simulation model.

Another way to improve stability and reduce peaking is to add a capacitor in parallel with the feedback resistor. As shown in Figure 16. [Peaking versus capacitive load, with or without feedback capacitor in inverting gain configuration](#), the feedback capacitor drastically reduces the peaking versus capacitive load (inverting gain configuration, gain = -2).

**Figure 15. In-series resistor vs. capacitive load when TSV99x is used in follower configuration**

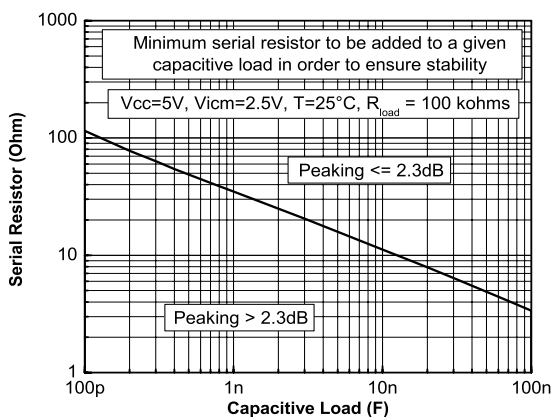

**Figure 16. Peaking versus capacitive load, with or without feedback capacitor in inverting gain configuration**

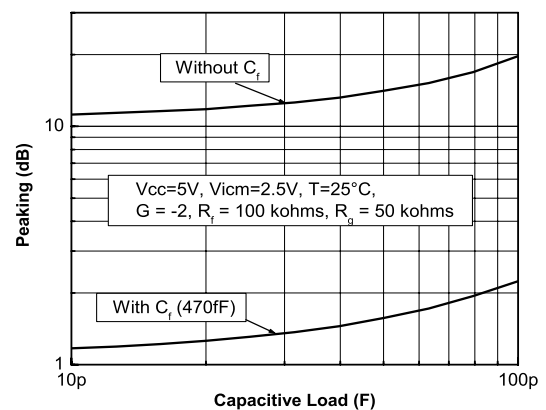

### 4.2 PCB layouts

For correct operation, it is advised to add 10 nF decoupling capacitors as close as possible to the power supply pins.

### 4.3 Macromodel

An accurate macromodel of the TSV99x is available on STMicroelectronics' web site at [www.st.com](http://www.st.com). This model is a trade-off between accuracy and complexity (that is, time simulation) of the TSV99x operational amplifiers. It emulates the nominal performance of a typical device within the specified operating conditions mentioned in the datasheet. It helps to validate a design approach and to select the right operational amplifier, however, it does not replace on-board measurements.

## 5 Package information

---

In order to meet environmental requirements, ST offers these devices in different grades of **ECOPACK** packages, depending on their level of environmental compliance. ECOPACK specifications, grade definitions and product status are available at: [www.st.com](http://www.st.com). ECOPACK is an ST trademark.

## 5.1 SOT23-5 package information

Figure 17. SOT23-5 package outline

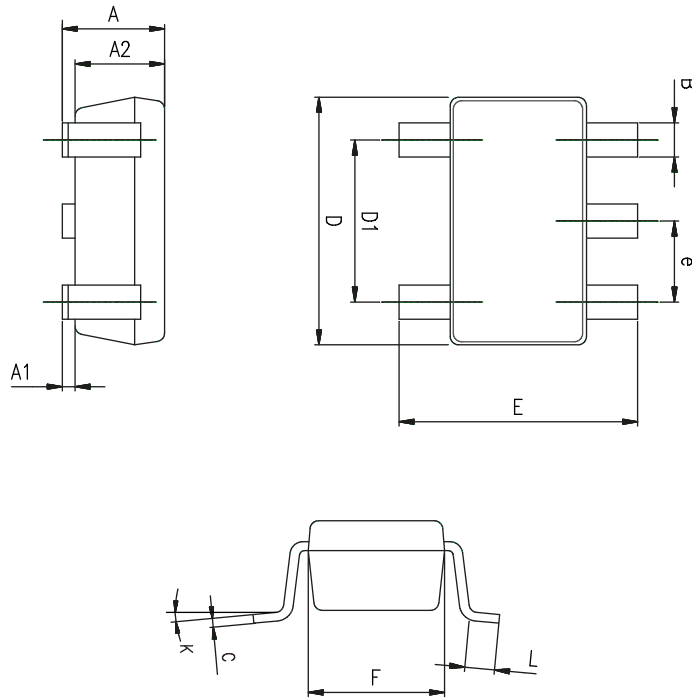

Table 6. SOT23-5 mechanical data

Ref.	Dimensions					
	Millimeters			Inches		
	Min.	Typ.	Max.	Min.	Typ.	Max.
A	0.90	1.20	1.45	0.035	0.047	0.057
A1			0.15			0.006
A2	0.90	1.05	1.30	0.035	0.041	0.051
B	0.35	0.40	0.50	0.014	0.016	0.020
C	0.09	0.15	0.20	0.004	0.006	0.008
D	2.80	2.90	3.00	0.110	0.114	0.118
D1		1.90			0.075	
e		0.95			0.037	
E	2.60	2.80	3.00	0.102	0.110	0.118
F	1.50	1.60	1.75	0.059	0.063	0.069
L	0.10	0.35	0.60	0.004	0.014	0.024
K	0 degrees		10 degrees	0 degrees		10 degrees

## 5.2 DFN8 2 x 2 package information

Figure 18. DFN8 2 x 2 package outline

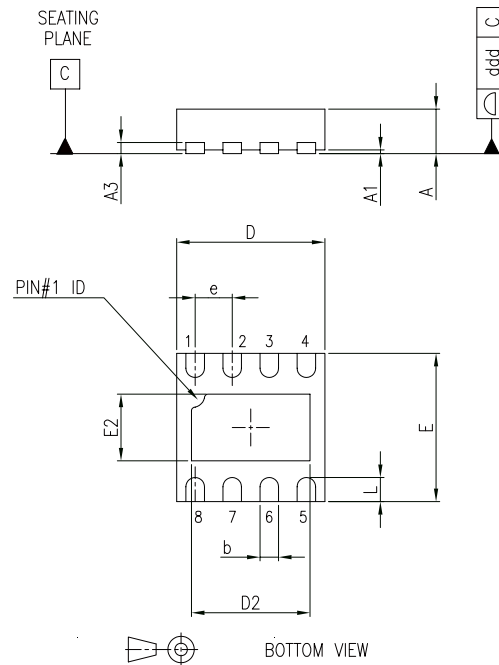
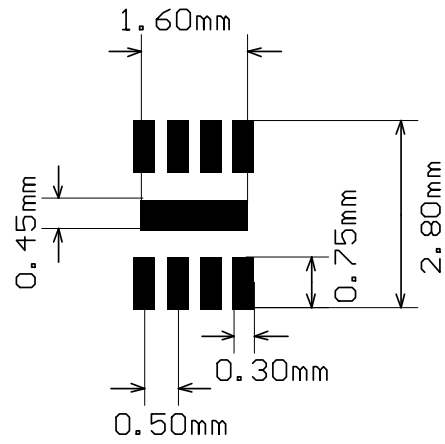

Table 7. DFN8 2 x 2 mechanical data

Ref.	Dimensions					
	Millimeters			Inches		
	Min.	Typ.	Max.	Min.	Typ.	Max.
A	0.51	0.55	0.60	0.020	0.022	0.024
A1			0.05			0.002
A3		0.15			0.006	
b	0.18	0.25	0.30	0.007	0.010	0.012
D	1.85	2.00	2.15	0.073	0.079	0.085
D2	1.45	1.60	1.70	0.057	0.063	0.067
E	1.85	2.00	2.15	0.073	0.079	0.085
E2	0.75	0.90	1.00	0.030	0.035	0.039
e		0.50			0.020	
L			0.425			0.017
ddd			0.08			0.003

Figure 19. DFN8 2 x 2 recommended footprint



*Note:* The exposed pad of the DFN8 2x2 package is not internally connected. It can be set to ground or left floating.

### 5.3 DFN6 1.3 x 1.6 x 0.55 package information

Figure 20. DFN6 1.3 x 1.6 x 0.55 package outline

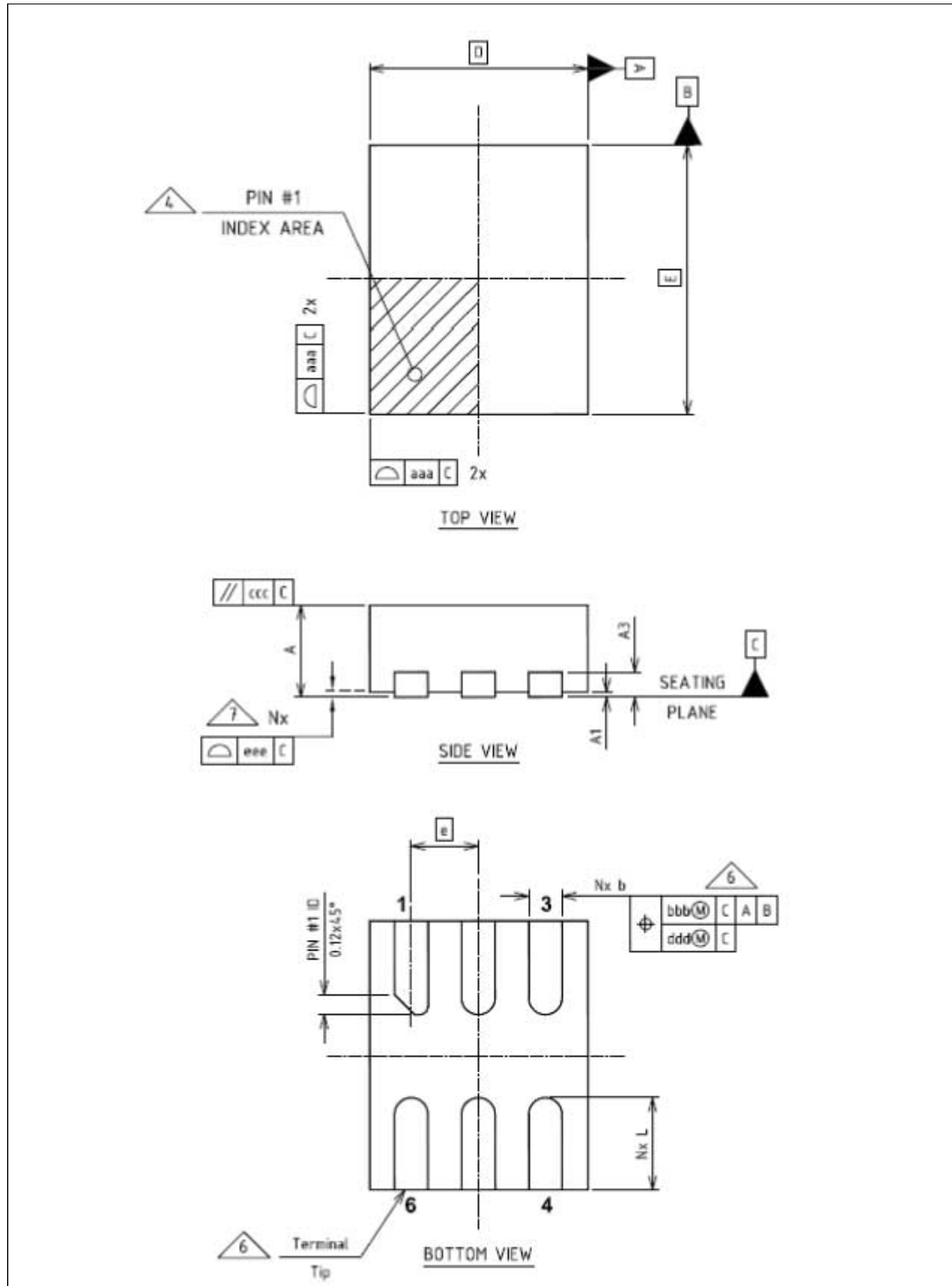
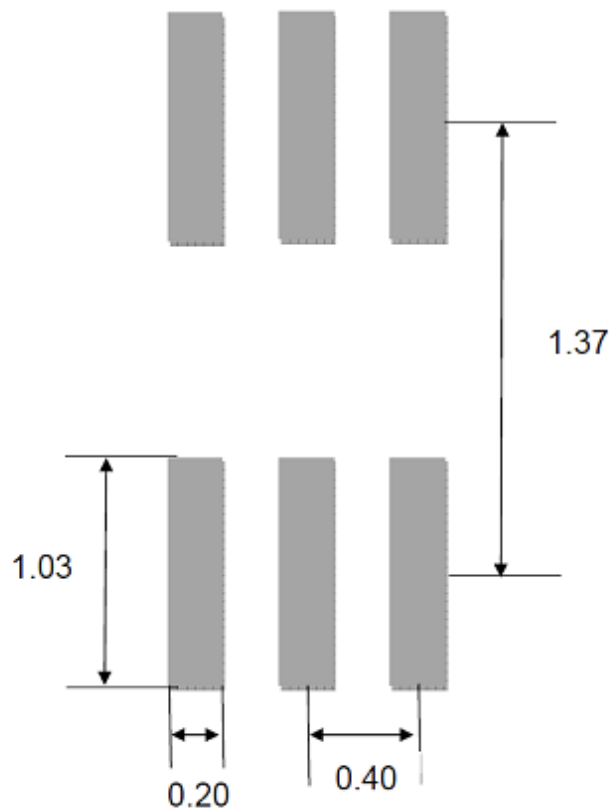

Table 8. DFN6 1.3 x 1.6 x 0.55 mechanical data

Ref.	Dimensions					
	Millimeters			Inches		
	Min.	Typ.	Max.	Min.	Typ.	Max.
A	0.50	0.55	0.60	0.020	0.022	0.024
A1	0.00	0.02	0.05	0.000	0.001	0.002
A3		0.15			0.006	
B	0.15	0.20	0.25	0.006	0.008	0.010
D		1.30			0.051	
E		1.60			0.063	
e		0.40			0.016	
L	0.453	0.553	0.653	0.018	0.022	0.026
N		6			0.236	
aaa		0.05			0.002	
bbb		0.07			0.003	
ccc		0.10			0.004	
ddd		0.05			0.002	
eee		0.08			0.003	

Figure 21. DFN6 1.3 x 1.6 x 0.55 recommended footprint



## 5.4 MiniSO8 package information

Figure 22. MiniSO8 package outline

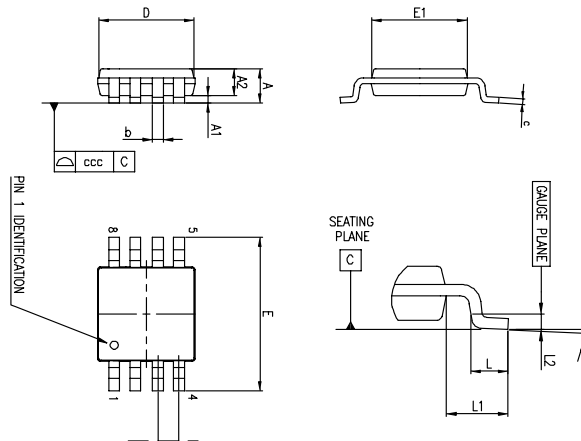

Table 9. MiniSO8 package mechanical data

Ref.	Dimensions					
	Millimeters			Inches		
	Min.	Typ.	Max.	Min.	Typ.	Max.
A			1.1			0.043
A1	0		0.15	0		0.0006
A2	0.75	0.85	0.95	0.030	0.033	0.037
b	0.22		0.40	0.009		0.016
c	0.08		0.23	0.003		0.009
D	2.80	3.00	3.20	0.11	0.118	0.126
E	4.65	4.90	5.15	0.183	0.193	0.203
E1	2.80	3.00	3.10	0.11	0.118	0.122
e		0.65			0.026	
L	0.40	0.60	0.80	0.016	0.024	0.031
L1		0.95			0.037	
L2		0.25			0.010	
k	0°		8°	0°		8°
ccc			0.10			0.004

## 5.5 SO8 package information

Figure 23. SO8 package outline

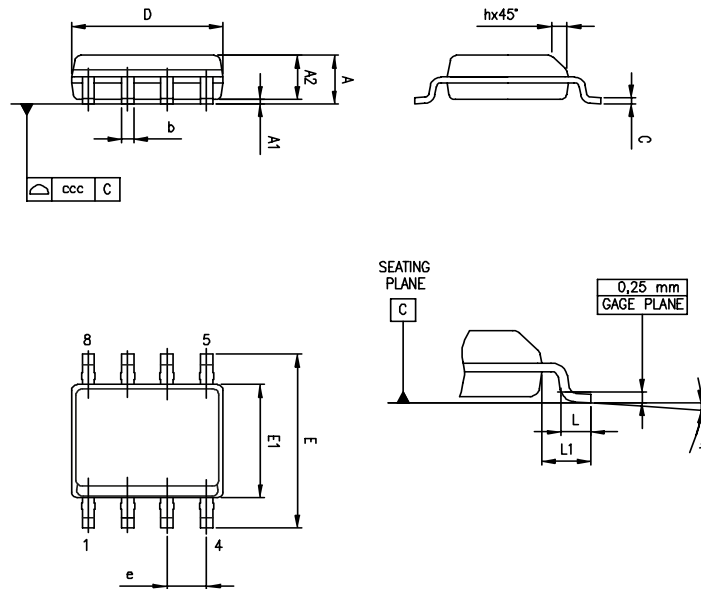

Table 10. SO8 package mechanical data

Ref.	Dimensions					
	Millimeters			Inches		
	Min.	Typ.	Max.	Min.	Typ.	Max.
A			1.75			0.069
A1	0.10		0.25	0.004		0.010
A2	1.25			0.049		
b	0.28		0.48	0.011		0.019
c	0.17		0.23	0.007		0.010
D	4.80	4.90	5.00	0.189	0.193	0.197
E	5.80	6.00	6.20	0.228	0.236	0.244
E1	3.80	3.90	4.00	0.150	0.154	0.157
e		1.27			0.050	
h	0.25		0.50	0.010		0.020
L	0.40		1.27	0.016		0.050
L1		1.04			0.040	
k	0°		8°	0°		8°
ccc			0.10			0.004

## 5.6 SO14 package information

Figure 24. SO14 package outline

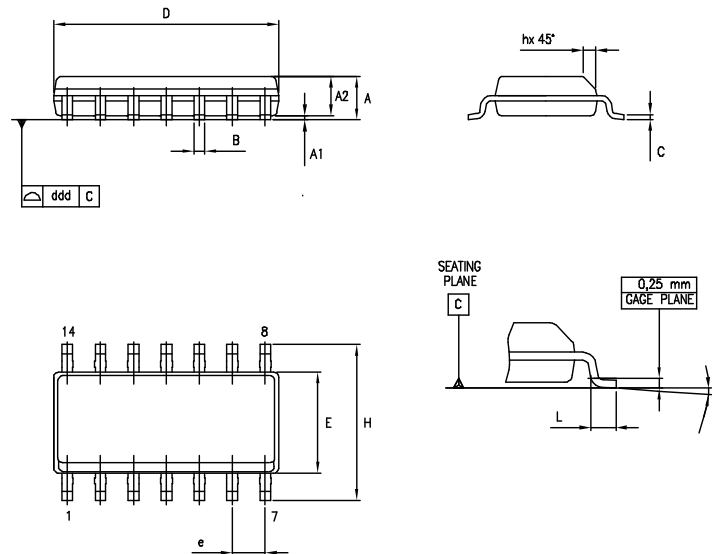

Table 11. SO14 package mechanical data

Ref.	Dimensions					
	Millimeters			Inches		
	Min.	Typ.	Max.	Min.	Typ.	Max.
			1.75			0.069
A	1.35		1.75	0.05		0.068
A1	0.10		0.25	0.004		0.009
A2	1.10		1.65	0.04		0.06
B	0.33		0.51	0.01		0.02
C	0.19		0.25	0.007		0.009
D	8.55		8.75	0.33		0.34
E	3.80		4.0	0.15		0.15
e		1.27			0.05	
H	5.80		6.20	0.22		0.24
h	0.25		0.50	0.009		0.02
L	0.40		1.27	0.015		0.05
k	8° (max.)					
ddd			0.10			0.004

## 5.7 TSSOP14 package information

Figure 25. TSSOP14 package outline

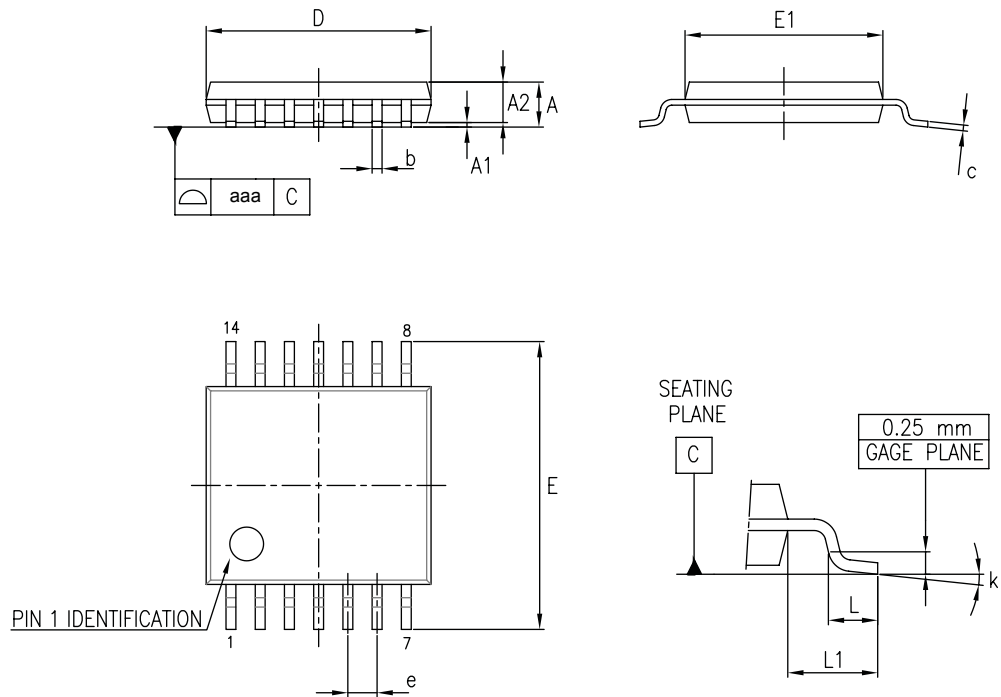

Table 12. TSSOP14 package mechanical data

Ref.	Dimensions					
	Millimeters			Inches		
	Min.	Typ.	Max.	Min.	Typ.	Max.
A			1.20			0.047
A1	0.05		0.15	0.002	0.004	0.006
A2	0.80	1.00	1.05	0.031	0.039	0.041
b	0.19		0.30	0.007		0.012
c	0.09		0.20	0.004		0.0089
D	4.90	5.00	5.10	0.193	0.197	0.201
E	6.20	6.40	6.60	0.244	0.252	0.260
E1	4.30	4.40	4.50	0.169	0.173	0.176
e		0.65			0.0256	
L	0.45	0.60	0.75	0.018	0.024	0.030
L1		1.00			0.039	
k	0°		8°	0°		8°
aaa			0.10			0.004

## 6 Ordering information

**Table 13. Order code**

Order code	Temperature range	Package	Packing	Marking
TSV991ILT	-40 °C to 125 °C	SOT23-5	Tape and reel	K130
TSV991AILT				K129
TSV991IQ2T		DFN8 2x2		K1F
TSV991AIQ2T				K1E
TSV991AIQ1T		DFN6 1.3x1.6x0.55		K5
TSV992IST		MiniSO8		K132
TSV992AIST				K135
TSV992IDT		SO8		V992I
TSV992AIDT				V992AI
TSV992IQ2T		DFN8 2x2		K38
TSV994IPT		TSSOP14		V994I
TSV994AIPT				V994AI
TSV994IDT		SO14		V994I
TSV994AIDT				V994AI
TSV991IYLT <sup>(1)</sup>	-40 °C to 125 °C automotive grade	SOT23-5	K149	
TSV991AIYLT <sup>(1)</sup>			K150	
TSV992IYDT <sup>(1)</sup>		SO8	V992IY	
TSV992AIYDT <sup>(1)</sup>			V992AY	
TSV992IYST <sup>(1)</sup>		MiniSO8	K149	
TSV992AIYST <sup>(1)</sup>			K150	
TSV994IYDT <sup>(1)</sup>		SO14	V994IY	
TSV994AIYDT <sup>(1)</sup>			V994AY	
TSV994IYPT <sup>(1)</sup>		TSSOP14	V994IY	
TSV994AIYPT <sup>(1)</sup>			V994AY	

1. Qualified and characterized according to AEC Q100 and Q003 or equivalent, advanced screening according to AEC Q001 & Q 002 or equivalent.

**Note:** In the table above, all packages except the SO14 are "moisture sensitivity level 1" as per JEDEC J-STD-020-C. SO14 is JEDEC level 3.

## Revision history

**Table 14. Document revision history**

Date	Revision	Changes
31-Jul-2006	1	Preliminary data release for product under development.
07-Nov-2006	2	Final version of datasheet.
12-Dec-2006	3	Noise and distortion figures added.
07-Jun-2007	4	ESD tolerance modified for SO14, CDM in Table 1: "Absolute maximum ratings (AMR)". Automotive grade commercial products added in Table 13: "Order codes". Note about SO14 added in Table 13: "Order codes". Limits in temperature added in Section 2: "Electrical characteristics".
11-Feb-2008	5	Corrected MiniSO8 package information. Corrected footnote for automotive grade order codes in order code table. Improved presentation of package information.
25-May-2009	6	Added input current information in Table 1: "Absolute maximum ratings (AMR)". Added Section 3: "Application information". Updated all packages in Section 4: "Package information". Added new order codes: TSV991IYLT, TSV991AIYLT, TSV992IYST, TSV992AIYST, TSV994IYPT, TSV994AIYPT in Table 13: "Order codes".
19-Oct-2009	7	Added A versions of devices in title on cover page. Added parameters for full temperature range in Table 3, Table 4, and Table 5. Removed gain margin and phase margin parameters in Table 3, Table 4, and Table 5. These parameters have been replaced by the gain parameter (minimum gain for stability). Added Figure 14 and Figure 16.
14-Jan-2010	8	Added parameters for full temperature range in Table 3, Table 4, and Table 5. Modified note relative to automotive grade in Table 13: "Order codes".
22-Oct-2012	9	Document status changed to production data. Modified gain value in Features and Description. Added DFN8 2x2 pin connection diagram. Table 1: "Absolute maximum ratings (AMR)": added package DFN8 2x2 to rows $R_{thja}$ and ESD. Table 3, Table 4, and Table 5: replaced " $DV_{io}$ " with $\Delta V_{io}/\Delta T$ ; modified "Gain" and "THD +N" conditions and typical values. Figure 7 and Figure 8: added arrows indicating "Gain" and "Phase".
22-Oct-2012	9 cont'd	Figure 11 and Figure 12: updated. Added Figure 18: "DFN8 2 x 2 mm (NB) package outline" and Figure 19: "DFN8 2 x 2 mm (NB) recommended footprint". Table 13: "Order codes": updated automotive grade qualification and added order code of DFN8 package.
10-Mar-2014	10	Table 13: "Order codes": added new commercial product TSV991AIQ2T; corrected "Marking" error for TSV991IQ2T from K1E to K1F.
12-Jun-2015	11	Added DFN6 1.3 x 1.6 x 0.55 package for new order code TSV991AIQ1T. Updated "L" dimension of Section 4: "DFN8 2 x 2 mm (NB) package information". Updated min "k" value of Section 4.5: "SO8 package information".

Date	Revision	Changes
27-Nov-2015	12	Table 3, Table 4, and Table 5: modified that $R_L = 600 \Omega$ (not $600 \text{ k}\Omega$ ) for the high-level and low-level output voltage parameters. Section 5.2: updated name of package and titles of drawings and table; added note about exposed pad. Section 5.3: updated name of package.
03-Apr-2018	13	Updated cover image and Table 13. Order code.
19-Jun-2019	14	Updated the related product table in cover page.

## Contents

<b>1</b>	<b>Absolute maximum ratings and operating conditions</b>	<b>2</b>
<b>2</b>	<b>Electrical characteristics</b>	<b>4</b>
<b>3</b>	<b>Electrical characteristic curves</b>	<b>8</b>
<b>4</b>	<b>Application information</b>	<b>11</b>
4.1	Driving resistive and capacitive loads	11
4.2	PCB layouts	11
4.3	Macromodel	11
<b>5</b>	<b>Package information</b>	<b>12</b>
5.1	SOT23-5 package information	13
5.2	DFN8 2 x 2 package information	14
5.3	DFN6 1.3 x 1.6 x 0.55 package information	15
5.4	MiniSO8 package information	17
5.5	SO8 package information	19
5.6	SO14 package information	20
5.7	TSSOP14 package information	21
<b>6</b>	<b>Ordering information</b>	<b>22</b>
	<b>Revision history</b>	<b>23</b>
	<b>@NA</b>	<b>28</b>

## List of tables

<b>Table 1.</b>	Absolute maximum ratings (AMR) . . . . .	2
<b>Table 2.</b>	Operating conditions . . . . .	3
<b>Table 3.</b>	Electrical characteristics at $V_{CC+} = 2.5\text{ V}$ , $V_{CC-} = 0\text{ V}$ , $V_{icm} = V_{CC}/2$ , with $R_L$ connected to $V_{CC}/2$ , full temperature range (unless otherwise specified) . . . . .	4
<b>Table 4.</b>	Electrical characteristics at $V_{CC+} = 3.3\text{ V}$ , $V_{CC-} = 0\text{ V}$ , $V_{icm} = V_{CC}/2$ , with $R_L$ connected to $V_{CC}/2$ , full temperature range (unless otherwise specified) . . . . .	5
<b>Table 5.</b>	Electrical characteristics at $V_{CC+} = 5\text{ V}$ , $V_{CC-} = 0\text{ V}$ , $V_{icm} = V_{CC}/2$ , with $R_L$ connected to $V_{CC}/2$ , full temperature range (unless otherwise specified) . . . . .	6
<b>Table 6.</b>	SOT23-5 mechanical data . . . . .	13
<b>Table 7.</b>	DFN8 2 x 2 mechanical data . . . . .	14
<b>Table 8.</b>	DFN6 1.3 x 1.6 x 0.55 mechanical data . . . . .	17
<b>Table 9.</b>	MiniSO8 package mechanical data . . . . .	18
<b>Table 10.</b>	SO8 package mechanical data . . . . .	19
<b>Table 11.</b>	SO14 package mechanical data . . . . .	20
<b>Table 12.</b>	TSSOP14 package mechanical data . . . . .	21
<b>Table 13.</b>	Order code . . . . .	22
<b>Table 14.</b>	Document revision history . . . . .	23

## List of figures

<b>Figure 1.</b>	Input offset voltage distribution at $T = 25\text{ }^{\circ}\text{C}$ . . . . .	8
<b>Figure 2.</b>	Input offset voltage distribution at $T = 125\text{ }^{\circ}\text{C}$ . . . . .	8
<b>Figure 3.</b>	Supply current vs. input common-mode voltage at $V_{CC} = 2.5\text{ V}$ . . . . .	8
<b>Figure 4.</b>	Supply current vs. input common-mode voltage at $V_{CC} = 5\text{ V}$ . . . . .	8
<b>Figure 5.</b>	Output current vs. output voltage at $V_{CC} = 2.5\text{ V}$ . . . . .	8
<b>Figure 6.</b>	Output current vs. output voltage at $V_{CC} = 5\text{ V}$ . . . . .	8
<b>Figure 7.</b>	Voltage gain and phase vs. frequency at $V_{CC} = 5\text{ V}$ and $V_{icm} = 0.5\text{ V}$ . . . . .	9
<b>Figure 8.</b>	Voltage gain and phase vs. frequency at $V_{CC} = 5\text{ V}$ and $V_{icm} = 2.5\text{ V}$ . . . . .	9
<b>Figure 9.</b>	Positive slew rate . . . . .	9
<b>Figure 10.</b>	Negative slew rate . . . . .	9
<b>Figure 11.</b>	Distortion + noise vs. frequency . . . . .	9
<b>Figure 12.</b>	Distortion + noise vs. output voltage . . . . .	9
<b>Figure 13.</b>	Noise vs. frequency. . . . .	10
<b>Figure 14.</b>	Supply current vs. supply voltage . . . . .	10
<b>Figure 15.</b>	In-series resistor vs. capacitive load when TSV99x is used in follower configuration . . . . .	11
<b>Figure 16.</b>	Peaking versus capacitive load, with or without feedback capacitor in inverting gain configuration . . . . .	11
<b>Figure 17.</b>	SOT23-5 package outline . . . . .	13
<b>Figure 18.</b>	DFN8 2 x 2 package outline . . . . .	14
<b>Figure 19.</b>	DFN8 2 x 2 recommended footprint. . . . .	15
<b>Figure 20.</b>	DFN6 1.3 x 1.6 x 0.55 package outline . . . . .	16
<b>Figure 21.</b>	DFN6 1.3 x 1.6 x 0.55 recommended footprint . . . . .	17
<b>Figure 22.</b>	MiniSO8 package outline . . . . .	18
<b>Figure 23.</b>	SO8 package outline . . . . .	19
<b>Figure 24.</b>	SO14 package outline . . . . .	20
<b>Figure 25.</b>	TSSOP14 package outline . . . . .	21

**IMPORTANT NOTICE – PLEASE READ CAREFULLY**

STMicroelectronics NV and its subsidiaries (“ST”) reserve the right to make changes, corrections, enhancements, modifications, and improvements to ST products and/or to this document at any time without notice. Purchasers should obtain the latest relevant information on ST products before placing orders. ST products are sold pursuant to ST’s terms and conditions of sale in place at the time of order acknowledgement.

Purchasers are solely responsible for the choice, selection, and use of ST products and ST assumes no liability for application assistance or the design of Purchasers’ products.

No license, express or implied, to any intellectual property right is granted by ST herein.

Resale of ST products with provisions different from the information set forth herein shall void any warranty granted by ST for such product.



ST and the ST logo are trademarks of ST. For additional information about ST trademarks, please refer to [www.st.com/trademarks](http://www.st.com/trademarks). All other product or service names are the property of their respective owners.

Information in this document supersedes and replaces information previously supplied in any prior versions of this document.

© 2019 STMicroelectronics – All rights reserved

## Looking for pricing, stock, or lifecycle information?

Click below to explore more details on WIN SOURCE:

-  [View TSV991ILT](#) on WIN SOURCE
-  [STMicroelectronics](#) Information

## Optimize Your Supply Chain with WIN SOURCE Solutions

-  Global Sourcing Solution
-  Obsolete Management
-  Cost Control Management
-  Shortage Management
-  Alternative Solution
-  Excess Inventory Management