



THE DATASHEET OF ST202BTR



5 V powered multi-channel RS-232 drivers and receivers

Datasheet - production data

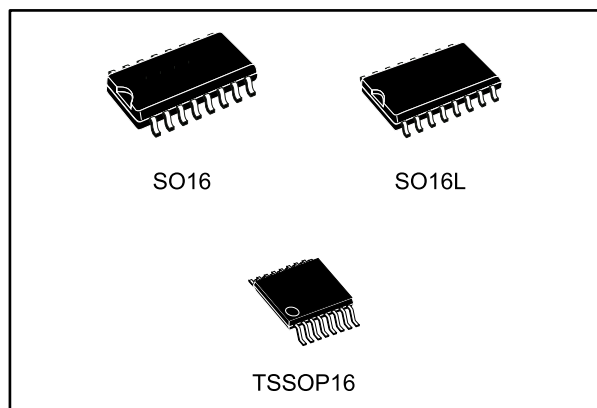
**Description**

The ST202B, ST202C is a two-driver, two-receiver device following EIA/TIA-232 and V.28 communication standards. It is particularly suitable for applications where ± 12 V is not available. The ST202B, ST202C uses a single 5 V power supply and only four external capacitors (0.1 μ F). Typical applications are in: portable computers, low power modems, interface translation, and battery-powered RS-232 networks.

Features

- Supply voltage range: 4.5 to 5.5 V
- Supply current no load (typ.): 1.5 mA
- Transmitter output voltage swing (typ): ± 9 V
- Transition slew rate (typ.): 12 V/ μ s
- Receiver propagation delay (typ.): 0.1 ms
- Compatible with MAX202
- Receiver input voltage range: ± 30 V
- Data rate (typ.): 400 kbps/s
- Operating temperature range: -40 to 85 °C, 0 to 70 °C

Contents

1	Pinout information.....	3
2	Absolute maximum ratings.....	4
3	Electrical characteristics	5
4	Typical application	7
5	Typical performance characteristics	8
6	Package information	9
6.1	SO16 package information.....	10
6.2	SO16L package information.....	11
6.3	TSSOP16 package information.....	12
6.4	SO16 tape and reel package information	13
6.5	SO16L tape and reel package information	14
6.6	TSSOP16 tape and reel package information	15
7	Ordering information.....	16
8	Revision history	17

1 Pinout information

Figure 1: Pin connections (top view)

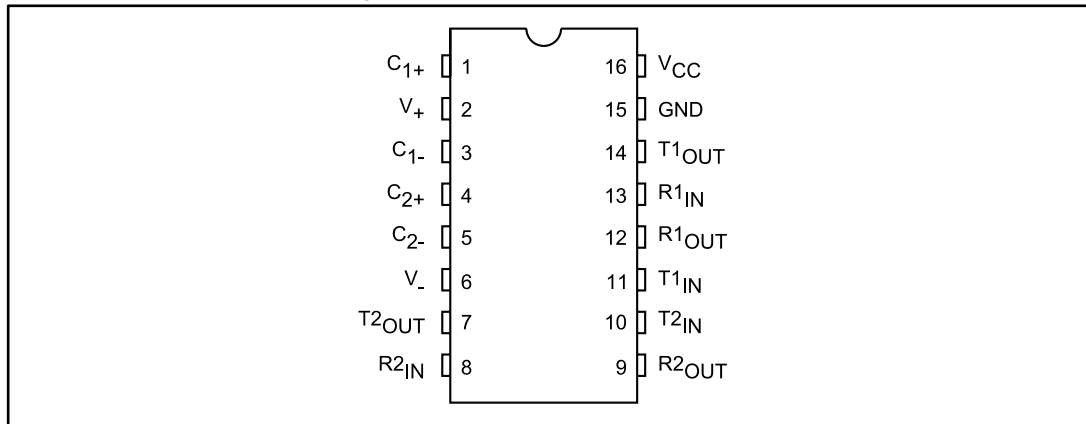

Table 1: Pin description

Pin n°	Symbol	Name and function
1	C ₁₊	Positive terminal for the first charge pump capacitor
2	V ₊	Doubled voltage terminal
3	C ₁₋	Negative terminal for the first charge pump capacitor
4	C ₂₊	Positive terminal for the second charge pump capacitor
5	C ₂₋	Negative terminal for the second charge pump capacitor
6	V ₋	Inverted voltage terminal
7	T _{2OUT}	Second transmitter output voltage
8	R _{2IN}	Second receiver input voltage
9	R _{2OUT}	Second receiver output voltage
10	T _{2IN}	Second transmitter input voltage
11	T _{1IN}	First transmitter input voltage
12	R _{1OUT}	First receiver output voltage
13	R _{1IN}	First receiver input voltage
14	T _{1OUT}	First transmitter output voltage
15	GND	Ground
16	V _{CC}	Supply voltage

2 Absolute maximum ratings

Absolute maximum ratings are those values beyond which damage to the device may occur. Functional operation under these conditions is not implied.

Table 2: Absolute maximum ratings

Symbol	Parameter	Value	Unit
V_{CC}	Supply voltage	-0.3 to 6	V
V+	Extra positive voltage	$(V_{CC} - 0.3)$ to 13.2	
V-	Extra negative voltage	0.3 to -13.2	
T_{IN}	Transmitter input voltage range	-0.3 to $(V_{CC} + 0.3)$	
R_{IN}	Receiver input voltage range	± 30	
T_{OUT}	Transmitter output voltage range	± 15	
R_{OUT}	Receiver output voltage range	-0.3 to $(V_{CC} + 0.3)$	
T_{SCTOUT}	Short circuit duration on T_{OUT}	Infinite	

3 Electrical characteristics

Table 3: Electrical characteristics, C1 - C4 = 0.1 μ F, V_{CC} = 5 V \pm 10 %, T_A = -40 to 85 °C, unless otherwise specified, typical values are referred to T_A = 25 °C

Symbol	Parameter	Test conditions	Min.	Typ.	Max.	Unit
I _{SUPPLY}	V _{CC} power supply current	No load	—	1.5	4	mA

Table 4: Transmitter electrical characteristics, C1 - C4 = 0.1 μ F, V_{CC} = 5 V \pm 10 %, T_A = -40 to 85 °C, unless otherwise specified, typical values are referred to T_A = 25 °C

Symbol	Parameter	Test conditions	Min.	Typ.	Max.	Unit
V _{TOUT}	Output voltage swing	All transmitter outputs are loaded with 3 k Ω to GND	\pm 5	\pm 9		V
I _{TIL}	Logic pull-up current	T _{IN} = 0 V		5	40	μ A
V _{TIL}	Input logic threshold low		0.8	1.4		V
V _{TIH}	Input logic threshold high			1.4	2	
SR _T	Transition slew rate	T _A = 25 °C, V _{CC} = 5 V, R _L = 3 to 7 k Ω , C _L = 50 to 2500 pF ⁽¹⁾	6	12	30	V/ μ s
D _R	Data rate	⁽²⁾	200	400		kbits/s
R _{TOUT}	Transmitter output resistance	V _{CC} = V ₊ = V ₋ = 0 V, V _{OUT} = \pm 2 V	300			Ω
I _{SC}	Transmitter output short circuit current	One T _{XOUT} to GND	\pm 7	\pm 22		mA
t _{DT}	Propagation delay time	TTL-CMOS IN to RS-232 OUT, C _L = 150 pF (50 % to 50 %)		1.3	3.5	μ s

Notes:

⁽¹⁾Measured from 3 V to -3 V or from -3 V to 3 V

⁽²⁾One transmitter output is loaded with R_L = 3 k Ω to 7 k Ω , C_L = 50 to 1000 pF

Table 5: Receiver electrical characteristics, C1 - C4 = 0.1 μ F, V_{CC} = 5 V \pm 10 %, T_A = -40 to 85 °C, unless otherwise specified, typical values are referred to T_A = 25 °C

Symbol	Parameter	Test conditions	Min.	Typ.	Max.	Unit
V _{RIN}	Receiver input voltage operating range		-30		30	V
R _{RIN}	RS-232 input resistance	T _A = 25 °C	3	5	7	k Ω
V _{RIL}	RS-232 input threshold low		0.8	1.3		V
V _{RIH}	RS-232 input threshold high			1.8	2.4	
V _{RIHYS}	RS-232 input hysteresis	V _{CC} = 5 V	0.2	0.5	1	
V _{ROL}	TTL/CMOS output voltage low	I _{OUT} = 3.2 mA (to V _{CC})		0.2	0.4	
V _{ROH}	TTL/CMOS output voltage high	I _{OUT} = 1 mA (to GND)	3.5	V _{CC} - 0.2		
I _{SCR}	Receiver output short circuit current	To GND	2	10		mA
		To V _{CC}	10	30		
t _{DR}	Propagation delay time	C _L = 150 pF ⁽¹⁾		0.1	0.5	μ s

Notes:

⁽¹⁾RS-232 in to TTL-CMOS out (from 50 % to 50 %)

4 Typical application

Figure 2: Application circuit

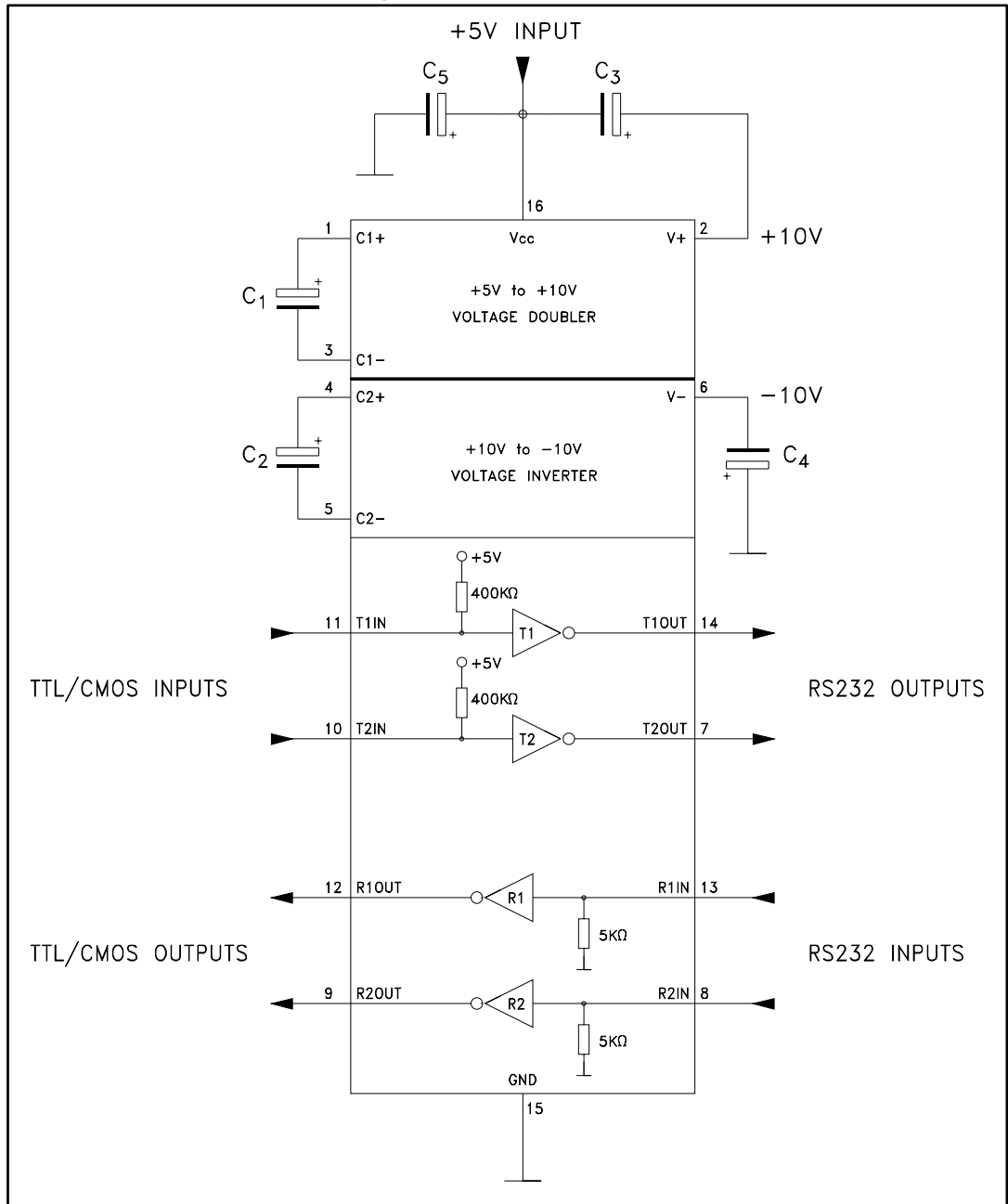

1. C₁₋₄ can be replaced by the 1 μF capacitors
2. C₁₋₄ can be common or biased capacitors

Table 6: Capacitance value (μF)

C1	C2	C3	C4	C5
		0.1		

5 Typical performance characteristics

Unless otherwise specified $T_J = 25\text{ }^\circ\text{C}$.

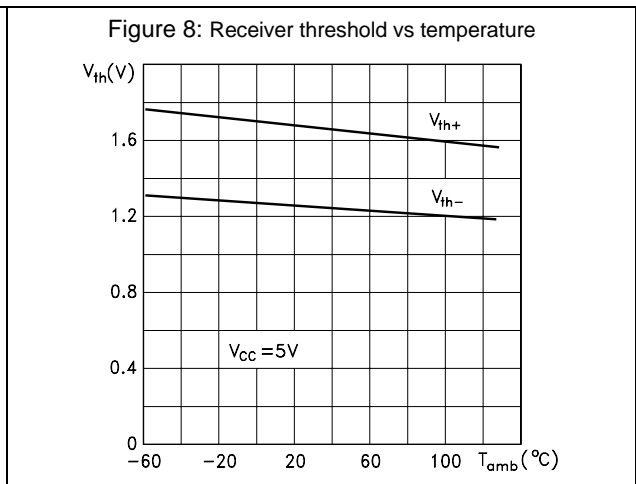
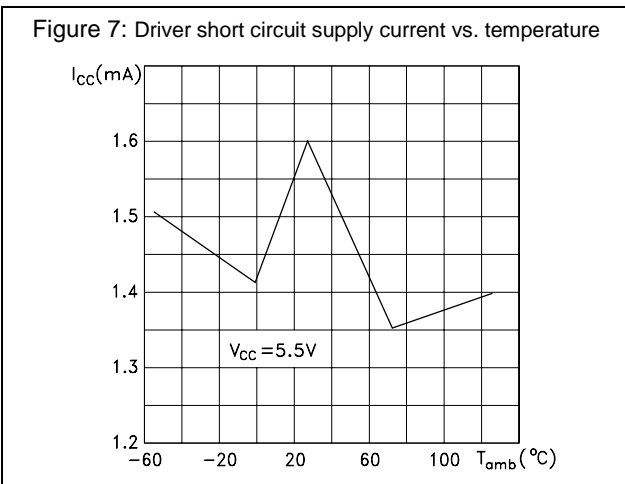
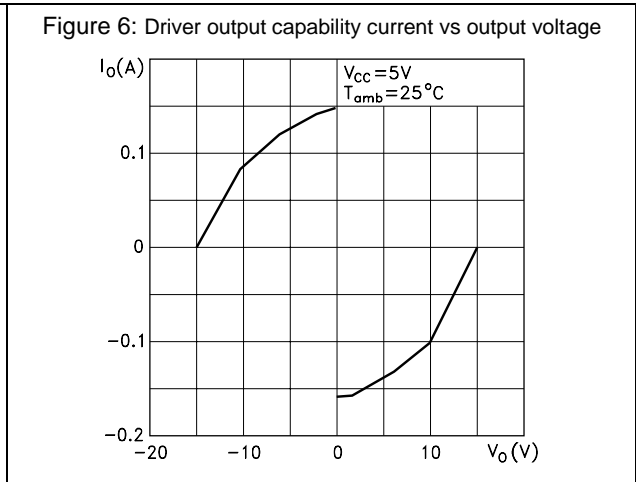
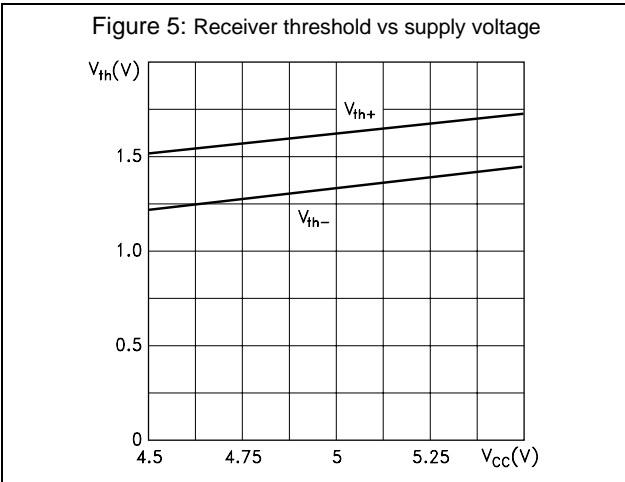
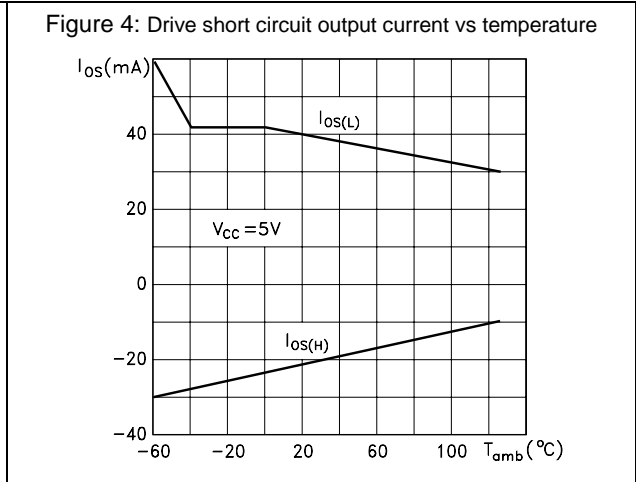
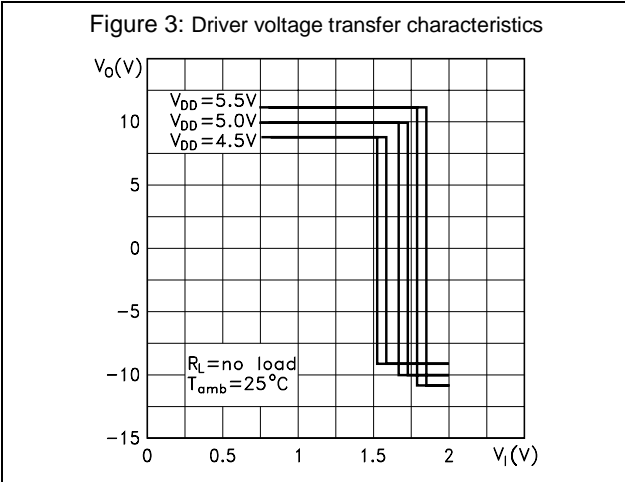

6 Package information

In order to meet environmental requirements, ST offers these devices in different grades of ECOPACK® packages, depending on their level of environmental compliance. ECOPACK® specifications, grade definitions and product status are available at: www.st.com. ECOPACK® is an ST trademark.

6.1 SO16 package information

Figure 9: SO16 package outline

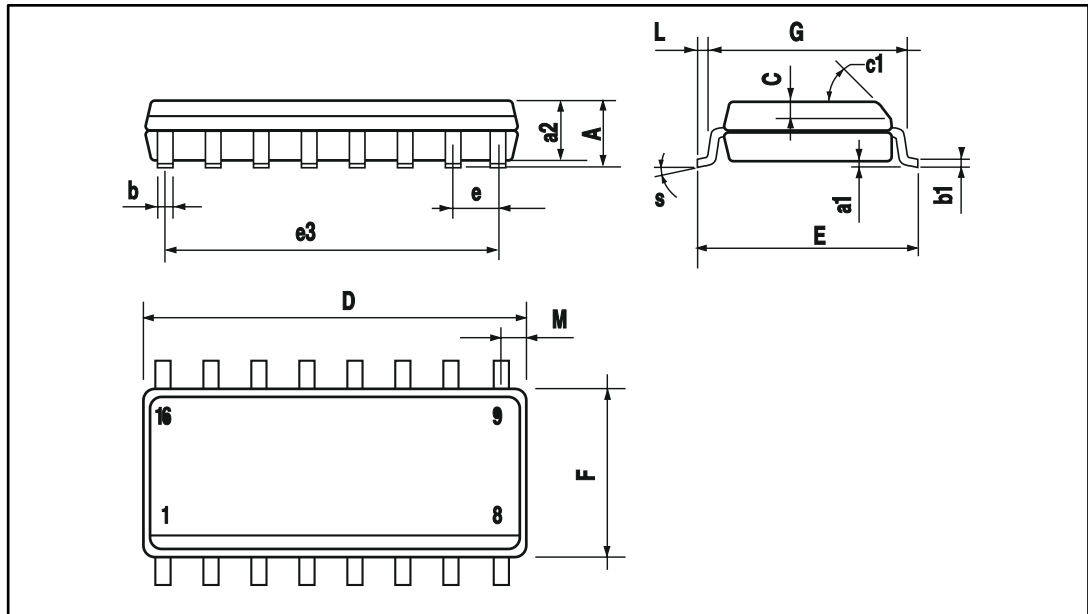

Table 7: SO16 mechanical data

Ref	Dimensions					
	Millimeters			Inches		
	Min.	Typ.	Max	Min.	Typ.	Max.
A			1.75			0.068
a1	0.1		0.25	0.004		0.010
a2			1.64			0.063
b	0.35		0.46	0.013		0.018
b1	0.19		0.25	0.007		0.010
C		0.5			0.019	
c1		45 °			45 °	
D	9.8		10	0.385		0.393
E	5.8		6.2	0.228		0.244
e		1.27			0.050	
e3		8.89			0.350	
F	3.8		4.0	0.149		0.157
G	4.6		5.3	0.181		0.208
L	0.5		1.27	0.019		0.050
M			0.62			0.024
S			8 °			8 °

6.2 SO16L package information

Figure 10: SO16L package outline

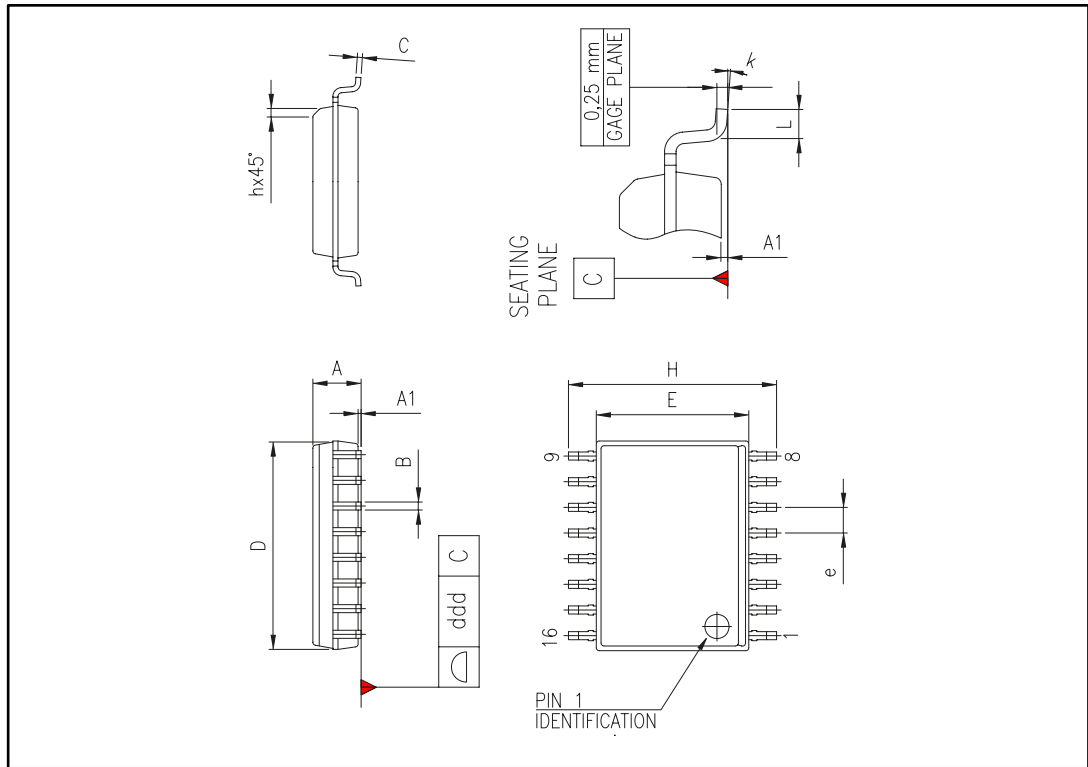

Table 8: SO16L mechanical data

Ref	Dimensions					
	Millimeters			Inches		
	Min.	Typ.	Max	Min.	Typ.	Max.
A	2.35		2.65	0.093		0.104
A1	0.1		0.3	0.004		0.012
B	0.33		0.51	0.013		0.02
C	0.23		0.32	0.009		0.013
D	10.1		10.5	0.398		0.413
E	7.4		7.6	0.291		0.299
e		1.27			0.05	
H	10		10.65	0.394		0.419
h	0.25		0.75	0.01		0.03
L	0.4		1.27	0.016		0.05
k	0°		8°	0°		8°
ddd			0.1			0.004

6.3 TSSOP16 package information

Figure 11: TSSOP16 package outline

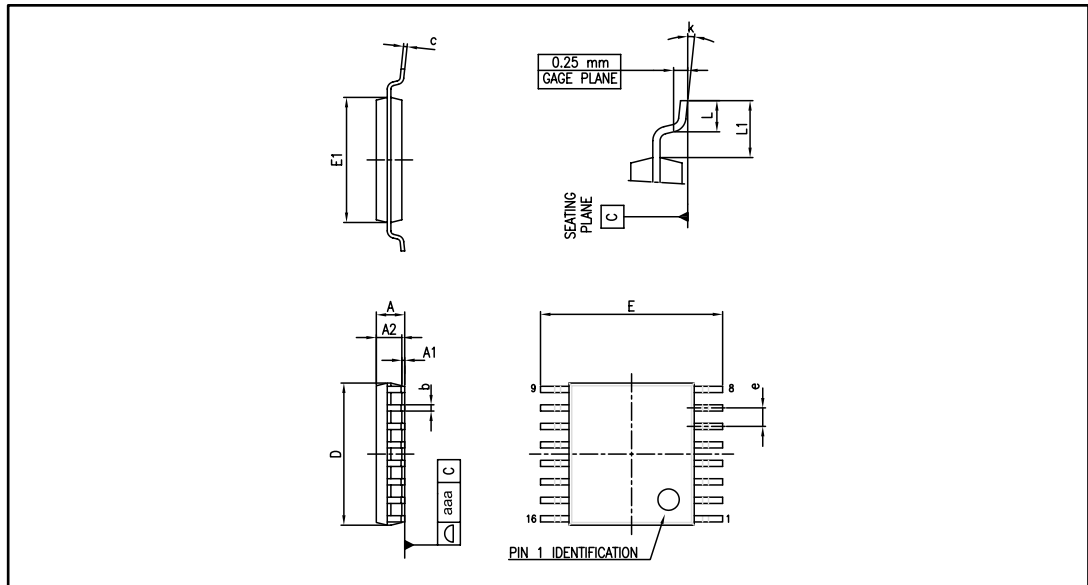
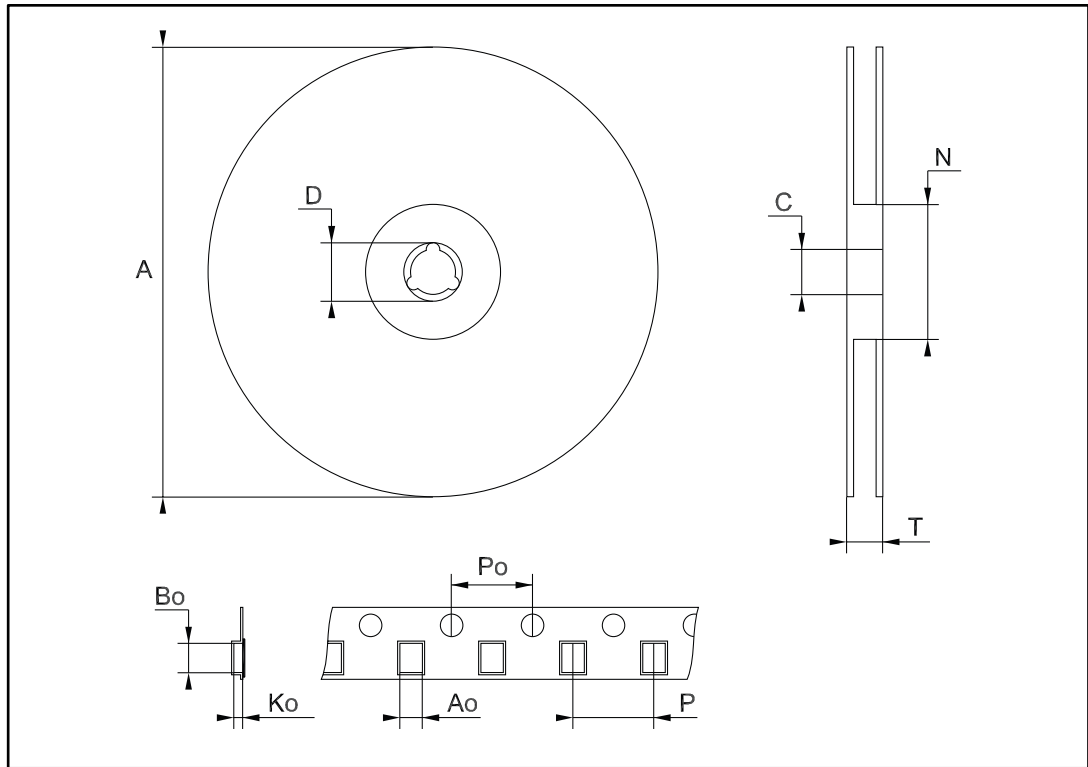

Table 9: TSSOP16 mechanical data

Ref	Dimensions					
	Millimeters			Inches		
	Min	Typ	Max	Min	Typ	Max
A			1.20			0.047
A1	0.05		0.15	0.002		0.006
A2	0.80	1.00	1.05	0.031	0.039	0.041
b	0.19		0.30	0.007		0.012
c	0.09		0.20	0.004		0.008
D	4.90	5.00	5.10	0.193	0.197	0.201
E	6.20	6.40	6.60	0.244	0.252	0.260
E1	4.30	4.40	4.50	0.169	0.173	0.177
e		0.65			0.026	
k	0°		8°	0°		8°
L	0.45	0.60	0.75	0.018	0.024	0.030
L1		1.00			0.039	
aaa			0.10			0.004

6.4 SO16 tape and reel package information

Figure 12: SO16 tape and reel package outline



1. Drawing not to scale

Table 10: SO16 tape and reel mechanical data

Ref	Dimensions					
	Millimeters			Inches		
	Min.	Typ.	Max	Min.	Typ.	Max.
A			330			12.992
C	12.8		13.2	0.504		0.519
D	20.2			0.795		
N	60			2.362		
T			22.4			0.882
Ao	6.45	—	6.65	0.254	—	0.262
Bo	10.3		10.5	0.406		0.414
Ko	2.1		2.3	0.082		0.090
Po	3.9		4.1	0.153		0.161
P	7.9		8.1	0.311		0.319

6.5 SO16L tape and reel package information

Figure 13: SO16L tape and reel package outline

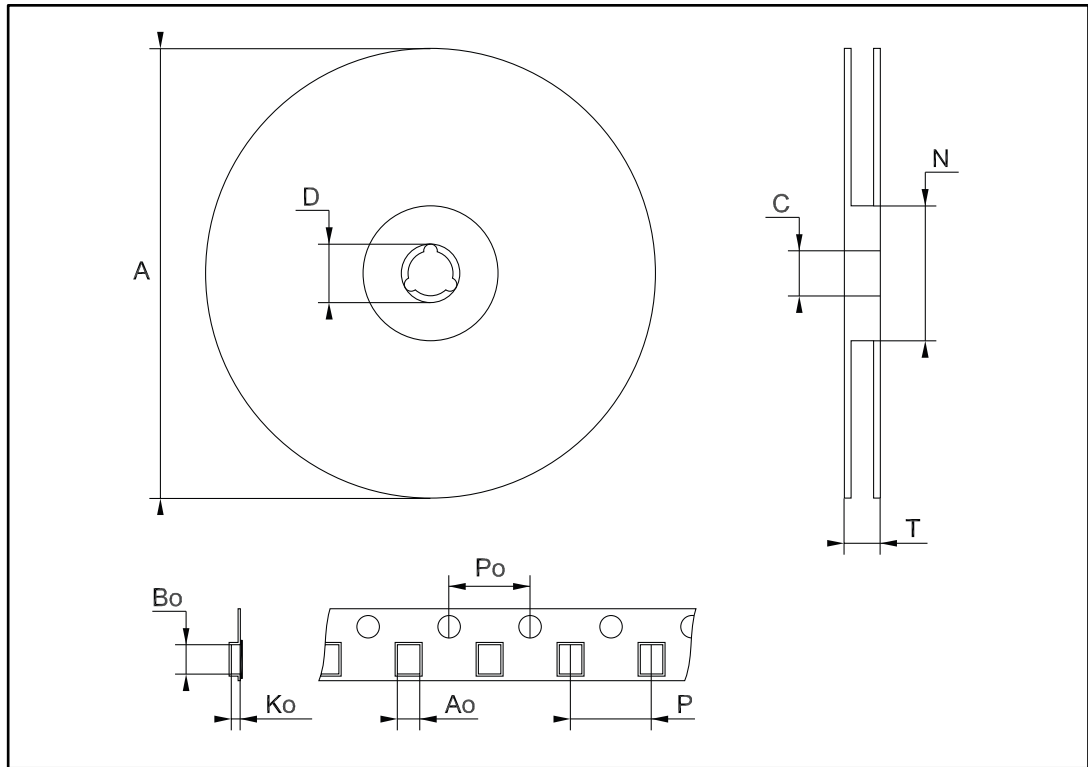

1. Drawing not to scale

Table 11: SO16L tape and reel mechanical data

Ref	Dimensions					
	Millimeters			Inches		
	Min.	Typ.	Max	Min.	Typ.	Max.
A			330			12.992
C	12.8		13.2	0.504		0.519
D	20.2			0.795		
N	60			2.362		
T			22.4			0.882
Ao	10.8	—	11.0	0.425	—	0.433
Bo	10.7		10.9	0.421		0.429
Ko	2.9		3.1	0.114		0.122
Po	3.9		4.1	0.153		0.161
P	11.9		12.1	0.468		0.476

6.6 TSSOP16 tape and reel package information

Figure 14: TSSOP16 tape and reel package outline

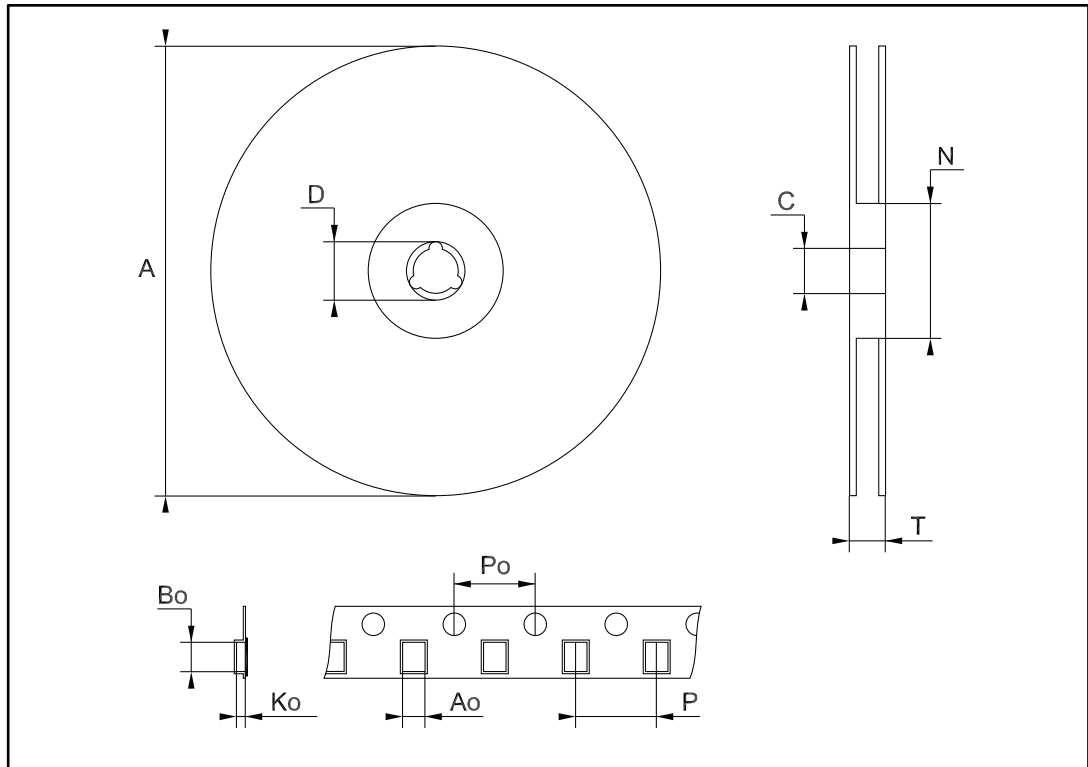

1. Drawing not to scale

Table 12: TSSOP16 tape and reel mechanical data

Ref	Dimensions					
	Millimeters			Inches		
	Min.	Typ.	Max	Min.	Typ.	Max.
A			330			12.992
C	12.8		13.2	0.504		0.519
D	20.2			0.795		
N	60			2.362		
T			22.4			0.882
Ao	6.7	—	6.9	0.264	—	0.272
Bo	5.3		5.5	0.209		0.217
Ko	1.6		1.8	0.063		0.071
Po	3.9		4.1	0.153		0.161
P	7.9		8.1	0.311		0.319

7 Ordering information

Table 13: Order codes

Order code	Temperature range	Package	Packaging	Marking
ST202BDR	-40 to 85 °C	S016 (tape and reel)	2500 parts per reel	ST202B
ST202CDR	0 to 70 °C			ST202C
ST202BTR	-40 to 85 °C	TSSOP16 (tape and reel)	1000 parts per reel	ST202B
ST202CWR	0 to 70 °C	S016L (tape and reel)		ST202C

8 Revision history

Table 14: Document revision history

Date	Revision	Changes
09-Mar-2006	5	Order codes updated and the document has been reformatted.
16-Jul-2007	6	Device summary updated.
14-Nov-2007	7	Modified: Table 1.
11-Feb-2008	8	Modified: Table 1 on page 1.
03-Mar-2017	9	<p><i>Cover image</i>: replaced silhouettes "SOP" and "SOP Large" with SO16 and SO16L respectively.</p> <p><i>Features</i>: updated units of transition slew rate (typ.) from 12 V/ms to 12 V/μs.</p> <p>Moved "Device summary" table to <i>Section 7: "Ordering information"</i> section. Removed obsolete order codes ST202BD and ST202CTR from this table and added "Markings".</p> <p><i>Section 6.2: "SO16L package information"</i>: replaced package outline and mechanical data.</p> <p><i>Section 6.3: "TSSOP16 package information"</i>: added dimensions "L1" and "aaa", replaced dimension "K" with "k", and removed BSC from dimension "e".</p>

IMPORTANT NOTICE – PLEASE READ CAREFULLY

STMicroelectronics NV and its subsidiaries ("ST") reserve the right to make changes, corrections, enhancements, modifications, and improvements to ST products and/or to this document at any time without notice. Purchasers should obtain the latest relevant information on ST products before placing orders. ST products are sold pursuant to ST's terms and conditions of sale in place at the time of order acknowledgement.

Purchasers are solely responsible for the choice, selection, and use of ST products and ST assumes no liability for application assistance or the design of Purchasers' products.

No license, express or implied, to any intellectual property right is granted by ST herein.

Resale of ST products with provisions different from the information set forth herein shall void any warranty granted by ST for such product.

ST and the ST logo are trademarks of ST. All other product or service names are the property of their respective owners.

Information in this document supersedes and replaces information previously supplied in any prior versions of this document.

© 2017 STMicroelectronics – All rights reserved

Looking for pricing, stock, or lifecycle information?

Click below to explore more details on WIN SOURCE:

-  [View ST202BTR on WIN SOURCE](#)
-  [STMicroelectronics Information](#)

Optimize Your Supply Chain with WIN SOURCE Solutions

-  Global Sourcing Solution
-  Obsolete Management
-  Cost Control Management
-  Shortage Management
-  Alternative Solution
-  Excess Inventory Management