



**THE DATASHEET OF
MM74HC574N**



MM74HC574

3-State Octal D-Type Edge-Triggered Flip-Flop

The MM74HC574 high speed octal D-type flip-flops utilize advanced silicon-gate P-well CMOS technology. They possess the high noise immunity and low power consumption of standard CMOS integrated circuits, as well as the ability to drive 15 LS-TTL loads. Due to the large output drive capability and the 3-STATE feature, these devices are ideally suited for interfacing with bus lines in a bus organized system.

These devices are positive edge triggered flip-flops. Data at the D inputs, meeting the set-up and hold time requirements, are transferred to the Q outputs on positive going transitions of the CLOCK (CK) input. When a high logic level is applied to the OUTPUT CONTROL (OC) input, all outputs go to a high impedance state, regardless of what signals are present at the other inputs and the state of the storage elements.

The 74HC logic family is speed, function, and pinout compatible with the standard 74LS logic family. All inputs are protected from damage due to static discharge by internal diode clamps to V_{CC} and ground.

Features

- Typical Propagation Delay: 18 ns
- Wide Operating Voltage Range: 2 V – 6 V
- Low Input Current: 1 μ A Maximum
- Low Quiescent Current: 80 μ A Maximum
- Compatible with Bus-oriented Systems
- Output Drive Capability: 15 LS-TTL Loads

MAXIMUM RATINGS (Note 1)

Rating	Symbol	Value	Unit
Supply Voltage	V_{CC}	-0.5 to +7.0 V	V
DC Input Voltage	V_{IN}	-1.5 to V_{CC} + 1.5 V	V
DC Output Voltage	V_{OUT}	-0.5 to V_{CC} + 0.5 V	V
Clamp Diode Current	I_{IK}, I_{OK}	± 20	mA
DC Output Current, per pin	I_{OUT}	± 35	mA
DC V_{CC} or GND Current, per pin	I_{CC}	± 70	mA
Storage Temperature Range	T_{STG}	-65 to +150	$^{\circ}$ C
Power Dissipation (Note 2) S.O. Package only	P_D	600 500	mW
Lead Temperature (Soldering 10 s)	T_L	260	$^{\circ}$ C

Stresses exceeding those listed in the Maximum Ratings table may damage the device. If any of these limits are exceeded, device functionality should not be assumed, damage may occur and reliability may be affected.

1. Unless otherwise specified all voltages are referenced to ground.
2. Power Dissipation temperature derating — plastic "N" package: - 12 mW/ $^{\circ}$ C from 65 $^{\circ}$ C to 85 $^{\circ}$ C.



ON Semiconductor®

www.onsemi.com



SOP20
SJ SUFFIX
CASE 565BG



TSSOP20
MTC SUFFIX
CASE 948AQ

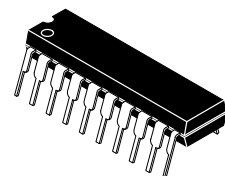

PDIP20
N SUFFIX
CASE 646AC

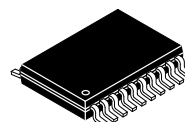

SOIC20
WM SUFFIX
CASE 751BJ

ORDERING INFORMATION

See detailed ordering and shipping information in the package dimensions section on page 2 of this data sheet.

MM74HC574

ORDERING CODE

Order Number	Package Number	Package Description
MM74HC574WM	M20B	20-Lead Small Outline Integrated Circuit (SOIC), JEDEC MS-013, 0.300" Wide
MM74HC574SJ	M20D	20-Lead Small Outline Package (SOP), EIAJ TYPE II, 5.3 mm Wide
MM74HC574MTC	MTC20	20-Lead Thin Shrink Small Outline Package (TSSOP), JEDEC MO-153, 4.4 mm Wide
MM74HC574N	N20A	20-Lead Plastic Dual-In-Line Package (PDIP), JEDEC MS-001, 0.300" Wide

Connection Diagram

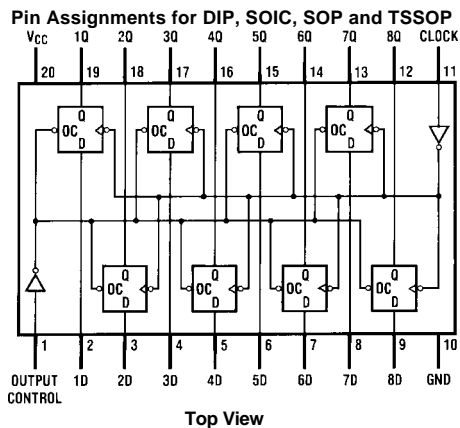

Truth Table

Output Control	Clock	Data	Output
L	↑	H	H
L	↑	L	L
L	L	X	Q ₀
H	X	X	Z

H = HIGH Level
 L = LOW Level
 X = Don't Care
 ↑ = Transition from Low-to-HIGH
 Z = High Impedance State
 Q₀ = The level of the output before steady state input conditions were established

RECOMMENDED OPERATING CONDITIONS

Symbol	Characteristic	Min	Typ	Max	Units
V _{CC}	Supply Voltage	2		6	V
V _{IN} , V _{OUT}	DC Input or Output Voltage	0		V _{CC}	V
T _A	Operating Temperature Range	-55		+125	°C
t _r , t _f	Input Rise or Fall Times			1000 500 400	ns
				V _{CC} = 2.0 V V _{CC} = 4.5 V V _{CC} = 6.0 V	

Functional operation above the stresses listed in the Recommended Operating Ranges is not implied. Extended exposure to stresses beyond the Recommended Operating Ranges limits may affect device reliability.

MM74HC574

DC ELECTRICAL CHARACTERISTICS (Note 3)

Symbol	Parameter	Conditions	V _{CC}	T _A = 25°C		T _A = -40 to 85°C	T _A = -55 to 125°C	Units
				Typ	Guaranteed Limits			
V _{IH}	Minimum HIGH Level Input Voltage		2.0 V		1.5	1.5	1.5	V
			4.5 V		3.15	3.15	3.15	
			6.0 V		4.2	4.2	4.2	
V _{IL}	Maximum LOW Level Input Voltage		2.0 V		0.5	0.5	0.5	V
			4.5 V		1.35	1.35	1.35	
			6.0 V		1.8	1.8	1.8	
V _{OH}	Minimum HIGH Level Output Voltage	V _{IN} = V _{IH} or V _{IL} I _{OUT} ≤ 20 μA	2.0 V	2.0	1.9	1.9	1.9	V
			4.5 V	4.5	4.4	4.4	4.4	
		6.0 V	6.0	5.9	5.9	5.9		
		4.5 V	4.2	3.98	3.84	3.7	V	
6.0 V	5.7	5.48	5.34	5.2				
V _{OL}	Maximum LOW Level Output Voltage	V _{IN} = V _{IH} or V _{IL} I _{OUT} ≤ 20 μA	2.0 V	0	0.1	0.1	0.1	V
			4.5 V	0	0.1	0.1	0.1	
		6.0 V	0	0.1	0.1	0.1		
		4.5 V	0.2	0.26	0.33	0.4	V	
6.0 V	0.2	0.26	0.33	0.4				
I _{IN}	Maximum Input Current	V _{IN} = V _{CC} or GND	6.0 V		±0.1	±1.0	±1.0	μA
I _{OZ}	Maximum 3-STATE Output Leakage Current	V _{OUT} = V _{CC} or GND OC = V _{IH}	6.0 V		±0.5	±5.0	±10	μA
I _{CC}	Maximum Quiescent Supply Current	V _{IN} = V _{CC} or GND I _{OUT} = 0 μA	6.0 V		8.0	80	160	μA
ΔI _{CC}	Quiescent Supply Current per Input Pin	V _{CC} = 5.5 V V _{IN} = 2.4 V or 0.4 V (Note 3)	OE	1.0	1.5	1.8	2.0	mA
			CLK	0.6	0.8	1.0	1.1	
			DATA	0.4	0.5	0.6	0.7	

Product parametric performance is indicated in the Electrical Characteristics for the listed test conditions, unless otherwise noted. Product performance may not be indicated by the Electrical Characteristics if operated under different conditions.

3. For a power supply of 5 V ±10% the worst-case output voltages (V_{OH}, and V_{OL}) occur for HC at 4.5 V. Thus the 4.5 V values should be used when designing with this supply. Worst-case V_{IH} and V_{IL} occur at V_{CC} = 5.5 V and 4.5 V respectively. (The V_{IH} value at 5.5 V is 3.85 V.) The worst-case leakage current (I_{IN}, I_{CC}, and I_{OZ}) occur for CMOS at the higher voltage and so the 6.0 V values should be used.

AC ELECTRICAL CHARACTERISTICS (V_{CC} = 5 V, T_A = 25°C, t_r = t_f = 6 ns)

Symbol	Parameter	Conditions	Typ	Guaranteed Limit	Units
f _{MAX}	Maximum Operating Frequency		60	33	MHz
t _{PHL} , t _{PLH}	Maximum Propagation Delay, Clock to Q	C _L = 45 pF	17	27	ns
t _{PZH} , t _{PZL}	Maximum Output Enable Time	R _L = 1 kΩ, C _L = 45 pF	19	28	ns
t _{PHZ} , t _{PLZ}	Maximum Output Disable Time	R _L = 1 kΩ, C _L = 5 pF	14	25	ns
t _S	Minimum Setup Time, Data to Clock		10	12	ns
t _H	Minimum Hold Time, Clock to Data		-3	5	ns
t _W	Minimum Pulse Clock Width		8	15	ns

MM74HC574

AC ELECTRICAL CHARACTERISTICS ($V_{CC} = 2.0 - 6.0$ V, $C_L = 50$ pF, $t_r = t_f = 6$ ns unless otherwise specified)

Symbol	Parameter	Conditions	V_{CC}	$T_A = 25^\circ\text{C}$		$T_A = -40$ to 85°C	$T_A = -55$ to 125°C	Units
				Typ	Guaranteed Limits			
f_{MAX}	Maximum Operating Frequency	$C_L = 50$ pF	2.0 V 4.5 V 6.0 V		33 30 35	28 24 28	23 20 23	MHz
t_{PHL}, t_{PLH}	Maximum Propagation Delay, Clock to Q	$C_L = 50$ pF $C_L = 150$ pF	2.0 V	18	30	38	45	ns
			2.0 V	51	155	194	233	
			4.5 V 4.5 V	13 19	23 31	29 47	35 47	
t_{PZH}, t_{PLZ}	Maximum Output Enable Time	$R_L = 1$ k Ω $C_L = 50$ pF $C_L = 150$ pF	2.0 V	22	30	38	45	ns
			2.0 V	59	180	225	270	
			4.5 V 4.5 V	14 20	28 36	35 45	42 54	
t_{PHZ}, t_{PLZ}	Maximum Output Disable Time	$R_L = 1$ k Ω $C_L = 50$ pF	2.0 V	15	30	38	45	ns
			4.5 V	12	25	31	38	
			6.0 V	10	21	27	32	
t_S	Minimum Setup Time Data to Clock		2.0 V 4.5 V 6.0 V	6	12 20 17	15 25 21	18 30 25	ns
t_H	Minimum Hold Time Clock to Data		2.0 V 4.5 V 6.0 V	-1	5 0 0	6 0 0	8 0 0	
t_{THL}, t_{TLH}	Maximum Output Rise and Fall Time	$C_L = 50$ pF	2.0 V 4.5 V 6.0 V	6 7 6	12 12 10	15 15 13	18 18 15	
t_W	Minimum Clock Pulse Width		2.0 V 4.5 V 6.0 V	30 9 8	15 16 14	20 20 18	24 24 20	ns
t_r, t_f	Maximum Clock Input Rise and Fall Time		2.0 V 4.5 V 6.0 V		1000 500 400	1000 500 400	1000 500 400	
C_{PD}		OC = V_{CC} OC = GND		5 58				
C_{IN}	Maximum Input Capacitance			5	10	10	10	pF
C_{OUT}	Maximum Output Capacitance			15	20	20	20	pF

4. C_{PD} determines the no load dynamic power consumption, $P_D = C_{PD} V_{CC}^2 f + I_{CC} V_{CC}$, and the no load dynamic current consumption, $I_S = C_{PD} V_{CC} f + I_{CC}$.

MM74HC574

PACKAGE DIMENSIONS

SOP20
CASE 565BG
ISSUE O

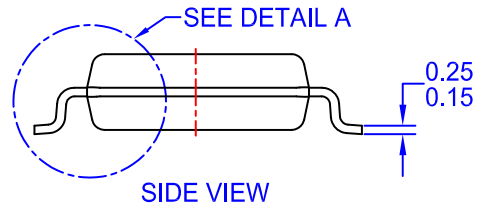
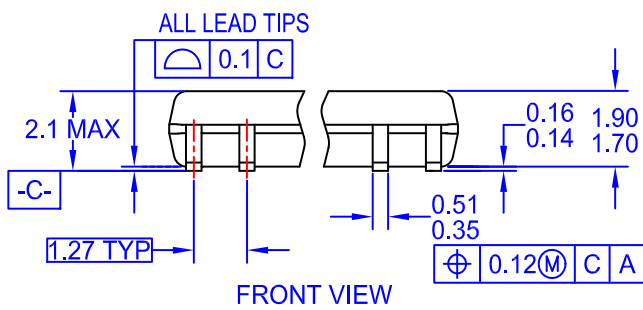
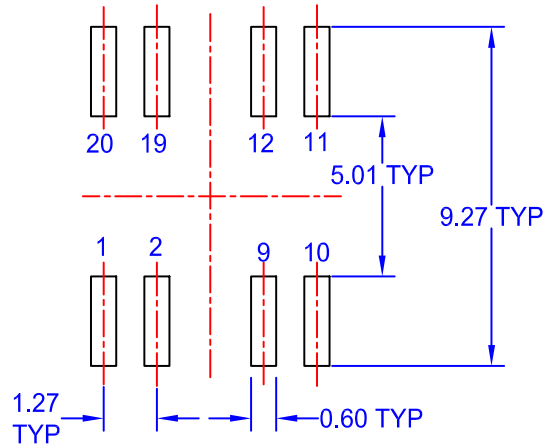
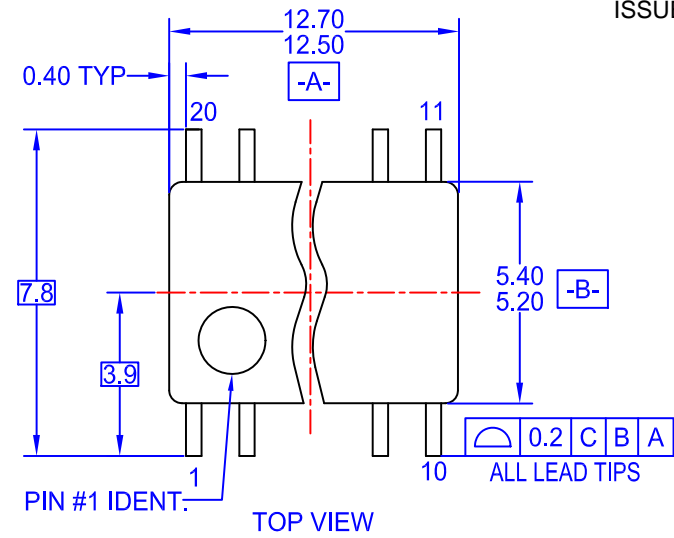

NOTES:

- A. CONFORMS TO EIAJ EDR-7320 REGISTRATION, ESTABLISHED IN DECEMBER, 1998.
- B. DIMENSIONS ARE IN MILLIMETERS.
- C. DIMENSIONS ARE EXCLUSIVE OF BURRS, MOLD FLASH, AND TIE BAR EXTRUSIONS.

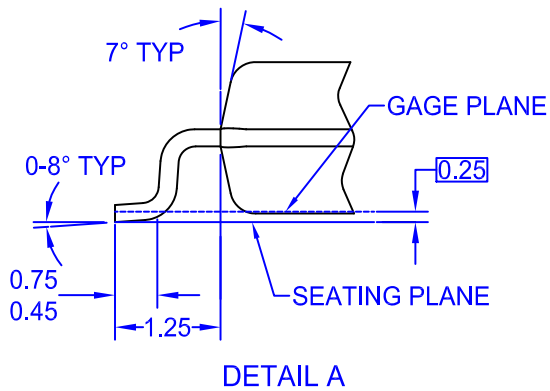

MM74HC574

PACKAGE DIMENSIONS

TSSOP20, 4.4x6.5
CASE 948AQ-01
ISSUE A

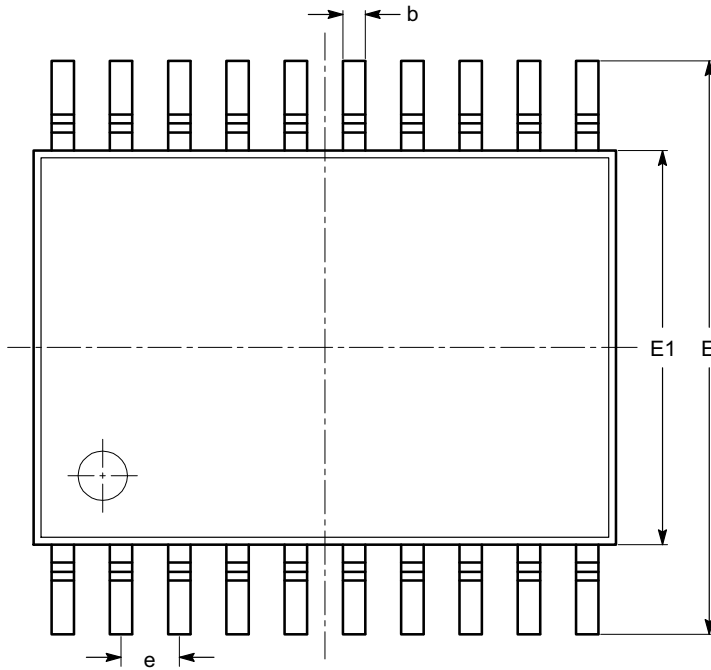

TOP VIEW

SYMBOL	MIN	NOM	MAX
A			1.20
A1	0.05		0.15
A2	0.80		1.05
b	0.19		0.30
c	0.09		0.20
D	6.40	6.50	6.60
E	6.30	6.40	6.50
E1	4.30	4.40	4.50
e	0.65 BSC		
L	0.45	0.60	0.75
L1	1.00 REF		
θ	0°		8°

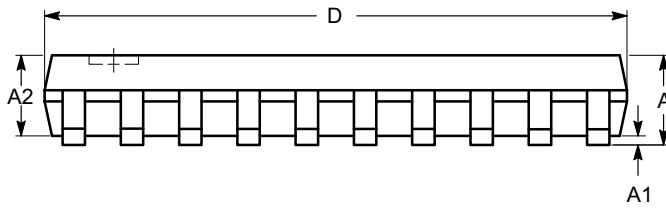

SIDE VIEW

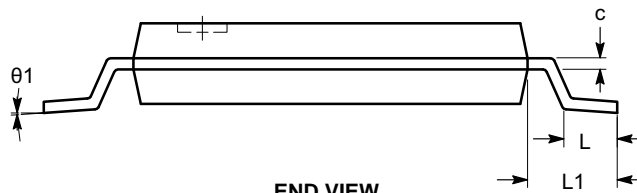

END VIEW

Notes:

- (1) All dimensions are in millimeters. Angles in degrees.
- (2) Complies with JEDEC MO-153.

MM74HC574

PACKAGE DIMENSIONS

PDIP-20, 300 mils
CASE 646AC-01
ISSUE A

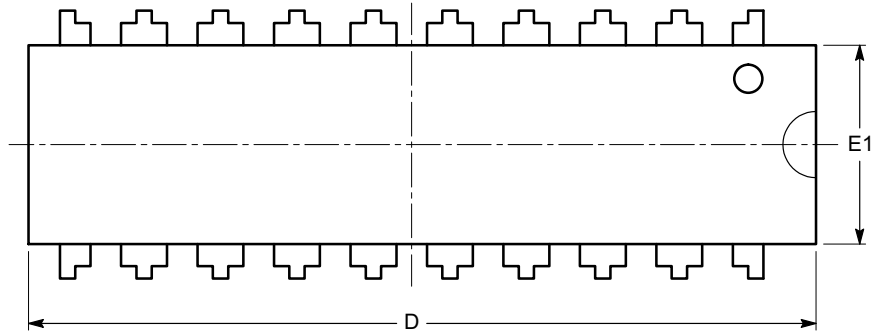

TOP VIEW

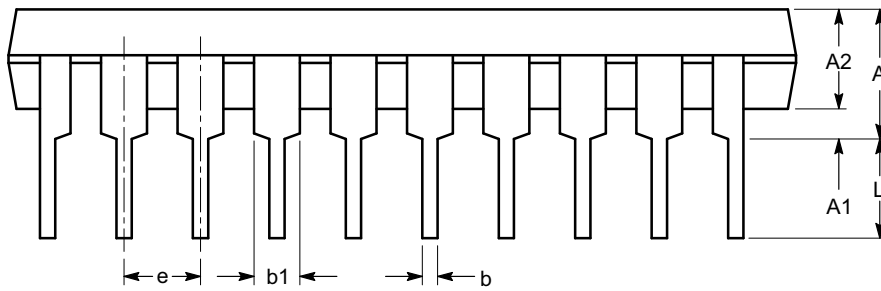

SIDE VIEW

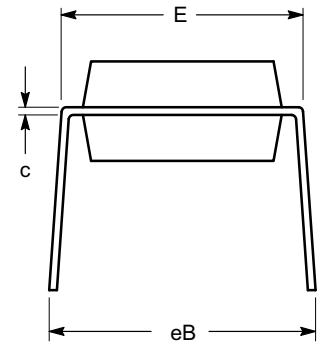

END VIEW

SYMBOL	MIN	NOM	MAX
A	3.56		5.33
A1	0.38		
A2	2.92	3.30	4.95
b	0.36	0.45	0.55
b1	1.15	1.52	1.77
c	0.21	0.26	0.35
D	24.89	26.16	26.92
E	7.62	7.87	8.25
E1	6.10	6.35	7.11
e	2.54 BSC		
eB	7.88		10.92
L	2.99	3.30	3.81

Notes:

- (1) All dimensions are in millimeters.
- (2) Complies with JEDEC MS-001.

MM74HC574

PACKAGE DIMENSIONS

SOIC-20, 300 mils
CASE 751BJ-01
ISSUE O

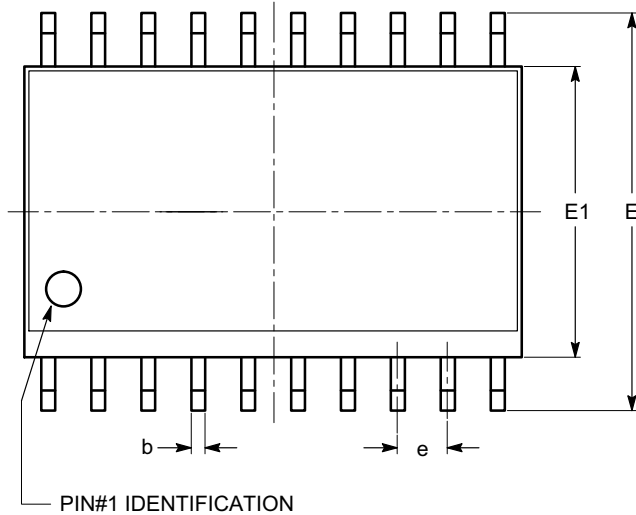

TOP VIEW

SYMBOL	MIN	NOM	MAX
A	2.36	2.49	2.64
A1	0.10		0.30
A2	2.05		2.55
b	0.31	0.41	0.51
c	0.20	0.27	0.33
D	12.60	12.80	13.00
E	10.01	10.30	10.64
E1	7.40	7.50	7.60
e	1.27 BSC		
h	0.25		0.75
L	0.40	0.81	1.27
θ	0°		8°
$\theta 1$	5°		15°

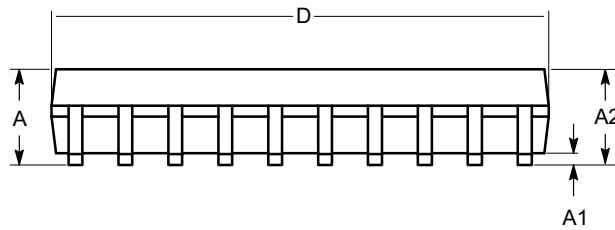

SIDE VIEW

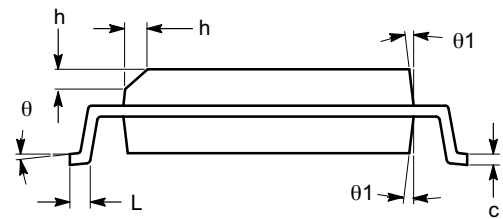

END VIEW

Notes:

- (1) All dimensions are in millimeters. Angles in degrees.
- (2) Complies with JEDEC MS-013.

ON Semiconductor and are trademarks of Semiconductor Components Industries, LLC dba ON Semiconductor or its subsidiaries in the United States and/or other countries. ON Semiconductor owns the rights to a number of patents, trademarks, copyrights, trade secrets, and other intellectual property. A listing of ON Semiconductor's product/patent coverage may be accessed at www.onsemi.com/site/pdf/Patent-Marking.pdf. ON Semiconductor reserves the right to make changes without further notice to any products herein. ON Semiconductor makes no warranty, representation or guarantee regarding the suitability of its products for any particular purpose, nor does ON Semiconductor assume any liability arising out of the application or use of any product or circuit, and specifically disclaims any and all liability, including without limitation special, consequential or incidental damages. Buyer is responsible for its products and applications using ON Semiconductor products, including compliance with all laws, regulations and safety requirements or standards, regardless of any support or applications information provided by ON Semiconductor. "Typical" parameters which may be provided in ON Semiconductor data sheets and/or specifications can and do vary in different applications and actual performance may vary over time. All operating parameters, including "Typicals" must be validated for each customer application by customer's technical experts. ON Semiconductor does not convey any license under its patent rights nor the rights of others. ON Semiconductor products are not designed, intended, or authorized for use as a critical component in life support systems or any FDA Class 3 medical devices or medical devices with a same or similar classification in a foreign jurisdiction or any devices intended for implantation in the human body. Should Buyer purchase or use ON Semiconductor products for any such unintended or unauthorized application, Buyer shall indemnify and hold ON Semiconductor and its officers, employees, subsidiaries, affiliates, and distributors harmless against all claims, costs, damages, and expenses, and reasonable attorney fees arising out of, directly or indirectly, any claim of personal injury or death associated with such unintended or unauthorized use, even if such claim alleges that ON Semiconductor was negligent regarding the design or manufacture of the part. ON Semiconductor is an Equal Opportunity/Affirmative Action Employer. This literature is subject to all applicable copyright laws and is not for resale in any manner.

PUBLICATION ORDERING INFORMATION

LITERATURE FULFILLMENT:

Literature Distribution Center for ON Semiconductor
19521 E. 32nd Pkwy, Aurora, Colorado 80011 USA
Phone: 303-675-2175 or 800-344-3860 Toll Free USA/Canada
Fax: 303-675-2176 or 800-344-3867 Toll Free USA/Canada
Email: orderlit@onsemi.com

N. American Technical Support: 800-282-9855 Toll Free
USA/Canada
Europe, Middle East and Africa Technical Support:
Phone: 421 33 790 2910
Japan Customer Focus Center
Phone: 81-3-5817-1050



ON Semiconductor Website: www.onsemi.com

Order Literature: <http://www.onsemi.com/orderlit>

For additional information, please contact your local Sales Representative

Looking for pricing, stock, or lifecycle information?

Click below to explore more details on WIN SOURCE:

-  [View MM74HC574N on WIN SOURCE](#)
-  [Fairchild/ON Semiconductor Information](#)

Optimize Your Supply Chain with WIN SOURCE Solutions

-  Global Sourcing Solution
-  Obsolete Management
-  Cost Control Management
-  Shortage Management
-  Alternative Solution
-  Excess Inventory Management