



**THE DATASHEET OF  
CS5308GDWR28**



# CS5308

## Two-Phase PWM Controller with Integrated Gate Drivers for VRM 8.5

The CS5308 is a second-generation, two-phase step down controller that incorporates all control functions required to power next generation processors. Proprietary multi-phase architecture guarantees balanced load current distribution and reduces overall solution cost in high current applications. Enhanced V<sup>2</sup>™ control architecture provides the fastest possible transient response, excellent overall regulation, and ease of use. The CS5308 is a second generation PWM controller because it optimizes transient response by combining traditional Enhanced V<sup>2</sup> with an internal PWM ramp and fast-feedback directly from V<sub>CORE</sub> to the internal PWM comparator. These enhancements provide greater design flexibility, facilitate use and reduce output voltage jitter.

The multi-phase architecture reduces input and output filter ripple, allowing for a significant reduction in filter size and inductor values with a corresponding increase in the output inductor current slew rate. This approach allows a considerable reduction in input and output capacitor requirements, as well as reducing overall solution size and cost.

The CS5308 includes VTT monitoring and timing, VTT Power Good (VTT<sub>PGD</sub>), Power Good (PWRGD), and internal MOSFET gate drivers to provide a “fully integrated solution” to simplify design, minimize circuit board area, and reduce overall system cost.

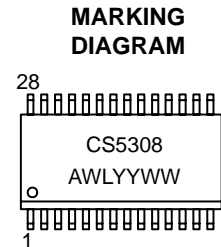
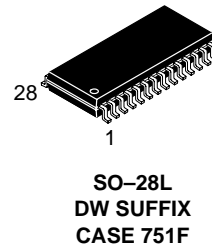
### Features

- Enhanced V<sup>2</sup> Control Method
- Internal PWM Ramp
- Fast-Feedback Directly from V<sub>CORE</sub>
- 5-Bit DAC with 1% Tolerance
- Adjustable Output Voltage Positioning
- 200 kHz to 800 kHz Operation Set by Resistor
- Current Sensed through Sense Resistors or Output Inductors
- Adjustable Hiccup Mode Current Limit
- Overvoltage Protection through Synchronous MOSFETs
- Individual Current Limits for Each Phase
- On-Board Current Share Amplifiers
- 3.3 V, 1.0 mA Reference Output
- VTT Monitoring and VTT Power Good (VTT<sub>PGD</sub>)
- V<sub>CORE</sub> Power Good
- On/Off Control (through COMP Pin)
- Improved Noise Immunity



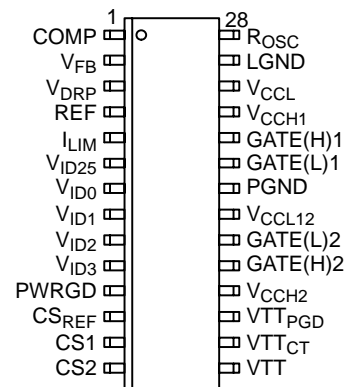
ON Semiconductor®

<http://onsemi.com>



A = Assembly Location  
WL, L = Wafer Lot  
YY, Y = Year  
WW, W = Work Week

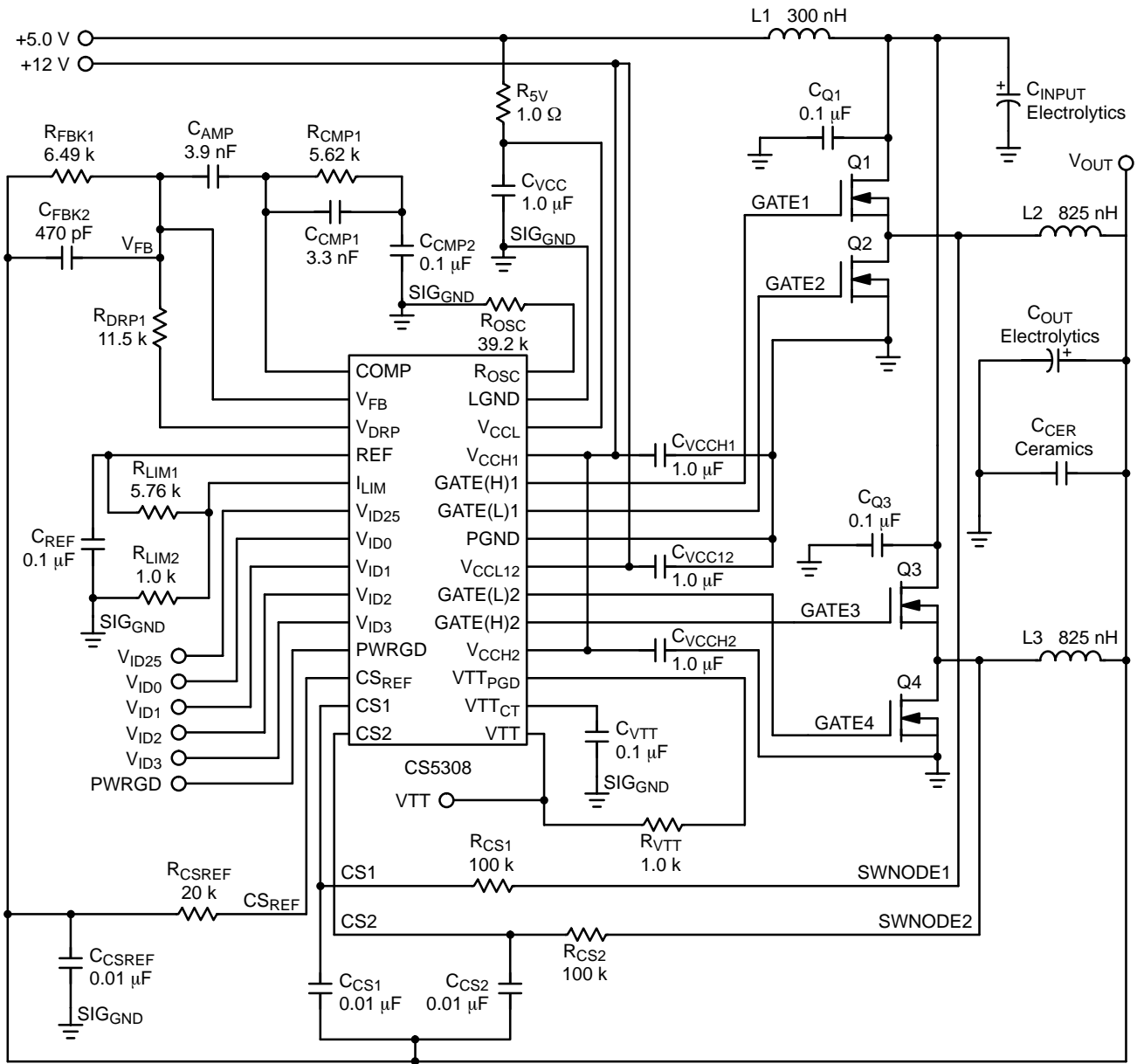
### PIN CONNECTIONS



### ORDERING INFORMATION

Device	Package	Shipping
CS5308GDW28	SO-28L	27 Units/Rail
CS5308GDWR28	SO-28L	1000 Tape & Reel

# CS5308



**Recommended Components:**

- L1: Coiltronics CTX15-14771 or T30-26 core with 3T of #16 AWG
- L2: Coiltronics CTX22-15401 X1 or T50-52 with 5T of #16 AWG Bifilar
- C<sub>INPUT</sub>: 2 × Sanyo Oscon 6SP680M (680 µF, 6.3 V)
- C<sub>OUT</sub>: 7 × Rubycon 6.3ZA1000M10x16 (1000 µF, 6.3 V)
- C<sub>CERAMICS</sub>: 12 × Panasonic ECJ-3YB0J106K (10 µF, 6.3 V)
- Q1-Q4: ON Semiconductor NTB85N03 (28 V, 85 A)

**Figure 1. Application Diagram. 5.0 V to 1.7 V at 28 A, 335 kHz with 12 V Bias for Pentium® III Applications**

# CS5308

## MAXIMUM RATINGS\*

Rating	Value	Unit
Operating Junction Temperature	150	°C
Lead Temperature Soldering: Reflow: (SMD styles only) (Note 1)	230 peak	°C
Storage Temperature Range	-65 to 150	°C
Package Thermal Resistance Junction-to-Case, $R_{\theta JC}$ Junction-to-Ambient, $R_{\theta JA}$	15 75	°C/W °C/W
ESD Susceptibility (Human Body Model)	2.0	kV
JEDEC Moisture Sensitivity	Level 2	-

1. 60 second maximum above 183°C.

\*The maximum package power dissipation must be observed.

## MAXIMUM RATINGS

Pin Name	$V_{MAX}$	$V_{MIN}$	$I_{SOURCE}$	$I_{SINK}$
COMP	6.0 V	-0.3 V	1.0 mA	1.0 mA
$V_{FB}$	6.0 V	-0.3 V	1.0 mA	1.0 mA
$V_{DRP}$	6.0 V	-0.3 V	1.0 mA	1.0 mA
CS1-CS2	6.0 V	-0.3 V	1.0 mA	1.0 mA
$CS_{REF}$	6.0 V	-0.3 V	1.0 mA	1.0 mA
PWRGD	6.0 V	-0.3 V	1.0 mA	8.0 mA
VID Pins	6.0 V	-0.3 V	1.0 mA	1.0 mA
$I_{LIM}$	6.0 V	-0.3 V	1.0 mA	1.0 mA
REF	6.0 V	-0.3 V	1.0 mA	20 mA
VTT	6.0 V	-0.3 V	1.0 mA	1.0 mA
$VTT_{CT}$	6.0 V	-0.3 V	1.0 mA	40 mA
$VTT_{PGD}$	6.0 V	-0.3 V	1.0 mA	8.0 mA
$V_{CCHx}$	20 V	-0.3 V	N/A	1.5 A for 1.0 $\mu$ s, 200 mA DC
GATE(H)x	20 V	-0.3 V DC -2.0 V for 100 ns	1.5 A for 1.0 $\mu$ s, 200 mA DC	1.5 A for 1.0 $\mu$ s, 200 mA DC
GATE(L)x	16 V	-0.3 V DC -2.0 V for 100 ns	1.5 A for 1.0 $\mu$ s, 200 mA DC	1.5 A for 1.0 $\mu$ s, 200 mA DC
$V_{CCL12}$	16 V	-0.3 V	N/A	1.5 A for 1.0 $\mu$ s, 200 mA DC
PGND	0.3 V	-0.3 V	2.0 A, 1.0 $\mu$ s, 200 mA DC	N/A
LGND	0 V	0 V	50 mA	N/A
$V_{CCL}$	16 V	-0.3 V	N/A	50 mA
$R_{OSC}$	6.0 V	-0.3 V	1.0 mA	1.0 mA

# CS5308

**ELECTRICAL CHARACTERISTICS** (0°C < T<sub>A</sub> < 70°C; 0°C < T<sub>J</sub> < 125°C; 9.0 V < V<sub>CCH1</sub> = V<sub>CCH2</sub> < 20 V; 4.5 V < V<sub>CCL</sub> = V<sub>CCL12</sub> < 14 V; C<sub>GATE</sub> = 3.3 nF, R<sub>ROSC</sub> = 32.4 k, C<sub>COMP</sub> = 0.1 μF, C<sub>REF</sub> = 0.1 μF, DAC Code 01000 (1.65 V), C<sub>VCC</sub> = 0.1 μF; unless otherwise specified.)

Characteristic					Test Conditions	Min	Typ	Max	Unit
<b>Voltage Identification DAC</b>									
Accuracy (all codes)					Measure V <sub>FB</sub> = COMP	–	–	± 1.0	%
V <sub>ID25</sub>	V <sub>ID3</sub>	V <sub>ID2</sub>	V <sub>ID1</sub>	V <sub>ID0</sub>	–	–	–	–	–
0	0	1	0	0	–	1.039	1.050	1.061	V
1	0	1	0	0	–	1.064	1.075	1.086	V
0	0	0	1	1	–	1.089	1.100	1.111	V
1	0	0	1	1	–	1.114	1.125	1.136	V
0	0	0	1	0	–	1.139	1.150	1.162	V
1	0	0	1	0	–	1.163	1.175	1.187	V
0	0	0	0	1	–	1.188	1.200	1.212	V
1	0	0	0	1	–	1.213	1.225	1.237	V
0	0	0	0	0	–	1.238	1.250	1.263	V
1	0	0	0	0	–	1.262	1.275	1.288	V
0	1	1	1	1	–	1.287	1.300	1.313	V
1	1	1	1	1	–	1.312	1.325	1.338	V
0	1	1	1	0	–	1.337	1.350	1.364	V
1	1	1	1	0	–	1.361	1.375	1.389	V
0	1	1	0	1	–	1.386	1.400	1.414	V
1	1	1	0	1	–	1.411	1.425	1.439	V
0	1	1	0	0	–	1.436	1.450	1.465	V
1	1	1	0	0	–	1.460	1.475	1.490	V
0	1	0	1	1	–	1.485	1.500	1.515	V
1	1	0	1	1	–	1.510	1.525	1.540	V
0	1	0	1	0	–	1.535	1.550	1.566	V
1	1	0	1	0	–	1.559	1.575	1.591	V
0	1	0	0	1	–	1.584	1.600	1.616	V
1	1	0	0	1	–	1.609	1.625	1.641	V
0	1	0	0	0	–	1.634	1.650	1.667	V
1	1	0	0	0	–	1.658	1.675	1.692	V
0	0	1	1	1	–	1.683	1.700	1.717	V
1	0	1	1	1	–	1.708	1.725	1.742	V
0	0	1	1	0	–	1.733	1.750	1.768	V
1	0	1	1	0	–	1.757	1.775	1.793	V
0	0	1	0	1	–	1.782	1.800	1.818	V
1	0	1	0	1	–	1.807	1.825	1.843	V
Input Threshold					V <sub>ID25</sub> , V <sub>ID3</sub> , V <sub>ID2</sub> , V <sub>ID1</sub> , V <sub>ID0</sub>	1.00	1.25	1.5	V
Input Pull-up Resistance					V <sub>ID25</sub> , V <sub>ID3</sub> , V <sub>ID2</sub> , V <sub>ID1</sub> , V <sub>ID0</sub>	25	50	100	kΩ
Pull-up Voltage					–	3.15	3.3	3.45	V

# CS5308

**ELECTRICAL CHARACTERISTICS (continued)** ( $0^{\circ}\text{C} < T_A < 70^{\circ}\text{C}$ ;  $0^{\circ}\text{C} < T_J < 125^{\circ}\text{C}$ ;  $9.0\text{ V} < V_{\text{CCH1}} = V_{\text{CCH2}} < 20\text{ V}$ ;  $4.5\text{ V} < V_{\text{CCL}} = V_{\text{CCL12}} < 14\text{ V}$ ;  $C_{\text{GATE}} = 3.3\text{ nF}$ ,  $R_{\text{ROSC}} = 32.4\text{ k}$ ,  $C_{\text{COMP}} = 0.1\text{ }\mu\text{F}$ ,  $C_{\text{REF}} = 0.1\text{ }\mu\text{F}$ , DAC Code 01000 (1.65 V),  $C_{\text{VCC}} = 0.1\text{ }\mu\text{F}$ ; unless otherwise specified.)

Characteristic	Test Conditions	Min	Typ	Max	Unit
----------------	-----------------	-----	-----	-----	------

## Power Good Output

Power Good Fault Delay	$CS_{\text{REF}} = \text{DAC to DAC} \pm 15\%$	25	50	100	$\mu\text{s}$
PWRGD Low Voltage	$I_{\text{PWRGD}} = 4.0\text{ mA}$	–	250	400	mV
Output Leakage Current	$V_{\text{PWRGD}} = 5.5\text{ V}$	–	0.1	10	$\mu\text{A}$
Lower Threshold	–	–15	–12	–9.0	%
Upper Threshold	–	9.0	12	15	%

## Voltage Feedback Error Amplifier

$V_{\text{FB}}$ Bias Current, (Note 2.)	$0.9\text{ V} < V_{\text{FB}} < 1.9\text{ V}$	9.4	10.3	11.1	$\mu\text{A}$
COMP Source Current	$\text{COMP} = 0.5\text{ V to } 2.0\text{ V}$ ; $V_{\text{FB}} = 1.6\text{ V}$	15	30	60	$\mu\text{A}$
COMP Sink Current	$\text{COMP} = 0.5\text{ V to } 2.0\text{ V}$ ; $V_{\text{FB}} = 1.7\text{ V}$	15	30	60	$\mu\text{A}$
COMP Discharge Threshold Voltage	–	0.20	0.27	0.34	V
Transconductance	$-10\text{ }\mu\text{A} < I_{\text{COMP}} < +10\text{ }\mu\text{A}$	–	32	–	mmho
Output Impedance	–	–	2.5	–	$\text{M}\Omega$
Open Loop DC Gain	Note 3.	60	90	–	dB
Unity Gain Bandwidth	$0.01\text{ }\mu\text{F}$	–	400	–	kHz
PSRR @ 1.0 kHz	–	–	70	–	dB
COMP Max Voltage	$V_{\text{FB}} = 1.6\text{ V COMP Open}$	2.4	2.7	–	V
COMP Min Voltage	$V_{\text{FB}} = 1.7\text{ V COMP Open}$	–	0.1	0.2	V
Hiccup Latch Discharge Current	–	2.0	5.0	10	$\mu\text{A}$
COMP Discharge Ratio	–	4.0	6.0	10	–

## PWM Comparators

Minimum Pulse Width	$CS1 = CS2 = CS_{\text{REF}}$	–	350	475	ns
Channel Startup Offset	$V(\text{CS1}) = V(\text{CS2}) = V(V_{\text{FB}}) = V(\text{CS}_{\text{REF}}) = 0\text{ V}$ ; Measure $V(\text{COMP})$ when GATE(H)1,2 switch high	0.3	0.4	0.5	V

## VTT Power Good

VTT Threshold	–	1.03	1.05	1.07	V
VTT <sub>PGD</sub> Low Voltage	$I_{\text{VTTPGD}} = 4.0\text{ mA}$	–	0.25	0.4	V
VTT <sub>PGD</sub> Leakage Current	$V_{\text{VTTPGD}} = 5.5\text{ V}$	–	0.1	10	$\mu\text{A}$
VTT <sub>CT</sub> Threshold Voltage	–	1.0	1.05	1.10	V
VTT <sub>CT</sub> Charge Current	Note 2.	15	30	45	$\mu\text{A}$
VTT <sub>CT</sub> Discharge Threshold	–	0.24	0.32	0.38	V

## GATES

High Voltage (AC)	Measure $V_{\text{CCx}} - \text{GATEx}$ , Note 3.	–	0	1.0	V
Low Voltage (AC)	Measure GATEx, Note 3.	–	0	0.5	V
Rise Time GATEx	$1.0\text{ V} < \text{GATE} < 8.0\text{ V}$ ; $V_{\text{CCx}} = 10\text{ V}$	–	35	80	ns

2. The  $V_{\text{FB}}$  Bias Current and VTT<sub>CT</sub> Charge Currents change with the value of  $R_{\text{OSC}}$  per Figure 4.

3. Guaranteed by design. Not tested in production.

# CS5308

**ELECTRICAL CHARACTERISTICS (continued)** ( $0^{\circ}\text{C} < T_A < 70^{\circ}\text{C}$ ;  $0^{\circ}\text{C} < T_J < 125^{\circ}\text{C}$ ;  $9.0\text{ V} < V_{\text{CCH1}} = V_{\text{CCH2}} < 20\text{ V}$ ;  $4.5\text{ V} < V_{\text{CCL}} = V_{\text{CCL12}} < 14\text{ V}$ ;  $C_{\text{GATE}} = 3.3\text{ nF}$ ,  $R_{\text{ROSC}} = 32.4\text{ k}$ ,  $C_{\text{COMP}} = 0.1\text{ }\mu\text{F}$ ,  $C_{\text{REF}} = 0.1\text{ }\mu\text{F}$ , DAC Code 01000 (1.65 V),  $C_{\text{VCC}} = 0.1\text{ }\mu\text{F}$ ; unless otherwise specified.)

Characteristic	Test Conditions	Min	Typ	Max	Unit
<b>GATES</b>					
Fall Time GATE <sub>x</sub>	$8.0\text{ V} > \text{GATE} > 1.0\text{ V}$ ; $V_{\text{CCx}} = 10\text{ V}$	–	35	80	ns
GATE(H) <sub>x</sub> to GATE(L) <sub>x</sub> Delay	$\text{GATE(H)}_x < 2.0\text{ V}$ , $\text{GATE(L)}_x > 2.0\text{ V}$	30	65	110	ns
GATE(L) <sub>x</sub> to GATE(H) <sub>x</sub> Delay	$\text{GATE(L)}_x < 2.0\text{ V}$ , $\text{GATE(H)}_x > 2.0\text{ V}$	30	65	110	ns
GATE Pull-down	Force 100 $\mu\text{A}$ into Gate with no power applied to $V_{\text{CCHx}}$ and $V_{\text{CCLx}} = 2.0\text{ V}$	–	1.2	1.6	V

## Oscillator

Switching Frequency	$R_{\text{OSC}} = 32.4\text{ k}$	340	400	460	kHz
Switching Frequency	$R_{\text{OSC}} = 63.4\text{ k}$ , Note 4.	150	200	250	kHz
Switching Frequency	$R_{\text{OSC}} = 16.2\text{ k}$ , Note 4.	600	800	1000	kHz
$R_{\text{OSC}}$ Voltage	–	–	1.0	–	V
Phase Delay	Rising edge only	165	180	195	deg

## Adaptive Voltage Positioning

$V_{\text{DRP}}$ Offset	$\text{CS1} = \text{CS2} = \text{CS}_{\text{REF}}$ , $V_{\text{FB}} = \text{COMP}$ , Measure $V_{\text{DRP}} - \text{COMP}$	–15	–	15	mV
$V_{\text{DRP}}$ Operating Voltage Range	Measure $V_{\text{DRP}} - \text{GND}$ , Note 4.	0.1	–	2.3	V
Maximum $V_{\text{DRP}}$ Voltage	$(\text{CS1} = \text{CS2}) - \text{CS}_{\text{REF}} = 50\text{ mV}$ , $V_{\text{FB}} = \text{COMP}$ Measure $V_{\text{DRP}} - \text{COMP}$	260	320	400	mV
Current Share Amp to $V_{\text{DRP}}$ Gain	–	2.6	3.2	4.0	V/V

## Current Sensing and Sharing

CS1 – CS2 Input Bias Current	$V(\text{Cx}) = V(\text{CS}_{\text{REF}}) = 0\text{ V}$	–	0.1	2.0	$\mu\text{A}$
$\text{CS}_{\text{REF}}$ Input Bias Current	–	–	0.5	2.0	$\mu\text{A}$
Current Sense Amplifier Gain	–	3.05	3.50	3.95	V/V
Current Sense Amp Mismatch (The sum of gain and offset errors.)	$0 < \text{CSx} - \text{CS}_{\text{REF}} < 50\text{ mV}$ . Note 4.	–5.0	–	5.0	mV
Current Sense Input to $I_{\text{LIM}}$ Gain	$I_{\text{LIM}} = 1.0\text{ V}$	5.5	6.5	7.5	V/V
Current Limit Filter Slew Rate	Note 4.	7.5	15	40	$\text{mV}/\mu\text{s}$
$I_{\text{LIM}}$ Operating Voltage Range	Note 4.	0.1	–	1.3	V
$I_{\text{LIM}}$ Bias Current	$0\text{ V} < I_{\text{LIM}} < 1.0\text{ V}$	–	0.1	1.0	$\mu\text{A}$
Single Phase Pulse by Pulse Current Limit: $V(\text{Cx}) - V(\text{CS}_{\text{REF}})$	–	90	105	135	mV
Current Sense Amplifier Bandwidth	Note 4.	1.0	–	–	MHz

4. Guaranteed by design. Not tested in production.

# CS5308

**ELECTRICAL CHARACTERISTICS (continued)** ( $0^{\circ}\text{C} < T_A < 70^{\circ}\text{C}$ ;  $0^{\circ}\text{C} < T_J < 125^{\circ}\text{C}$ ;  $9.0\text{ V} < V_{\text{CCH1}} = V_{\text{CCH2}} < 20\text{ V}$ ;  $4.5\text{ V} < V_{\text{CCL}} = V_{\text{CCL12}} < 14\text{ V}$ ;  $C_{\text{GATE}} = 3.3\text{ nF}$ ,  $R_{\text{ROSC}} = 32.4\text{ k}$ ,  $C_{\text{COMP}} = 0.1\text{ }\mu\text{F}$ ,  $C_{\text{REF}} = 0.1\text{ }\mu\text{F}$ , DAC Code 01000 (1.65 V),  $C_{\text{VCC}} = 0.1\text{ }\mu\text{F}$ ; unless otherwise specified.)

Characteristic	Test Conditions	Min	Typ	Max	Unit
----------------	-----------------	-----	-----	-----	------

## General Electrical Specifications

$V_{\text{CCL}}$ Operating Current	$V_{\text{FB}} = \text{COMP}$ (no switching)	–	20.5	26.0	mA
$V_{\text{CCL12}}$ Operating Current	$V_{\text{FB}} = \text{COMP}$ (no switching)	–	8.0	11	mA
$V_{\text{CCH1}}$ Operating Current	$V_{\text{FB}} = \text{COMP}$ (no switching)	–	2.8	4.0	mA
$V_{\text{CCH2}}$ Operating Current	$V_{\text{FB}} = \text{COMP}$ (no switching)	–	2.5	3.5	mA
$V_{\text{CCL}}$ Start Threshold	GATEs switching, COMP charging	4.05	4.3	4.5	V
$V_{\text{CCL}}$ Stop Threshold	GATEs stop switching, COMP discharging	3.75	4.1	4.35	V
$V_{\text{CCL}}$ Hysteresis	GATEs not switching, COMP not charging	100	200	300	mV
$V_{\text{CCH1}}$ Start Threshold	GATEs switching, COMP charging	8.0	8.5	9.0	V
$V_{\text{CCH1}}$ Stop Threshold	GATEs stop switching, COMP discharging	7.5	8.0	8.5	V
$V_{\text{CCH1}}$ Hysteresis	GATEs not switching, COMP not charging	300	500	700	mV

## Reference Output

$V_{\text{REF}}$ Output Voltage	$0\text{ mA} < I(V_{\text{REF}}) < 1.0\text{ mA}$	3.2	3.3	3.4	V
---------------------------------	---	-----	-----	-----	---

## Internal Ramp

Ramp Height @ 50% DTC	$CS1 = CS2 = CS_{\text{REF}}$	–	125	–	mV
-----------------------	-------------------------------	---	-----	---	----

5. Guaranteed by design. Not tested in production.

# CS5308

## PACKAGE PIN DESCRIPTION

PACKAGE PIN #	PIN SYMBOL	FUNCTION
28 Lead SO Wide		
1	COMP	Output of the error amplifier and input for the PWM comparators.
2	$V_{FB}$	Voltage Feedback Pin. To use Adaptive Voltage Positioning, set the light load offset voltage by connecting a resistor between $V_{FB}$ and $V_{OUT}$ . The resistor and the $V_{FB}$ bias current determine the offset. For no adaptive positioning connect $V_{FB}$ directly to $V_{OUT}$ .
3	$V_{DRP}$	Current sense output for Adaptive Voltage Positioning (AVP). The offset of this pin above the DAC voltage is proportional to the output current. Connect a resistor from this pin to $V_{FB}$ to set the amount of AVP or leave this pin open for no AVP. This pin's maximum working voltage is 2.3 Vdc.
4	REF	Reference output. Decouple to LGND with 0.1 $\mu$ F.
5	$I_{LIM}$	Sets threshold for current limit. Connect to reference through a resistive divider. This pin's maximum working voltage is 1.3 Vdc.
6–10	VID Pins	Voltage ID DAC inputs. These pins are internally pulled up to 3.3 V if left open.
11	PWRGD	Power Good Output. Open collector output goes low when $CS_{REF}$ is out of regulation.
12	$CS_{REF}$	Reference for current sense amplifiers, input to the Power Good comparators, and fast feedback connection to the PWM comparator. Connect this pin to the output voltage through a resistor equal to 1/5th the value of the current sense resistors. The input voltage to this pin must not exceed the maximum VID (DAC) setting by more than 100 mV.
13, 14	CS1–CS2	Current Sense inputs. Connect Current Sense network for the corresponding phase to each input. The input voltages to these pins must be kept within 105 mV of $CS_{REF}$ or pulse-by-pulse current limit will be triggered.
15	VTT	VTT sense input. The voltage on this pin must be higher than the VTT threshold (nominally 1.05 V) or switching will not occur.
16	$VTT_{CT}$	1.0 ms timer for VTT Power Good.
17	$VTT_{PGD}$	VTT Power Good output. Open collector, pulls down when $VTT < 1.03$ V.
18	$V_{CCH2}$	Power for channel 2 high side gate driver.
19, 20	GATE(H)2, GATE(L)2	High and low side gate drivers for channels 1 and 2.
21	$V_{CCL12}$	Power for both low side gate drivers.
22	PGND	Return for all gate drivers.
23, 24	GATE(L)1, GATE(H)1	Low and high side gate drivers for channels 1 and 2.
25	$V_{CCH1}$	Power for channel 1 high side gate driver.
26	$V_{CCL}$	Power for logic. UVLO Sense for supply connects to this pin.
27	LGND	Ground for internal control circuits and the IC substrate connection.
28	$R_{OSC}$	A resistor from this pin to ground sets operating frequency.

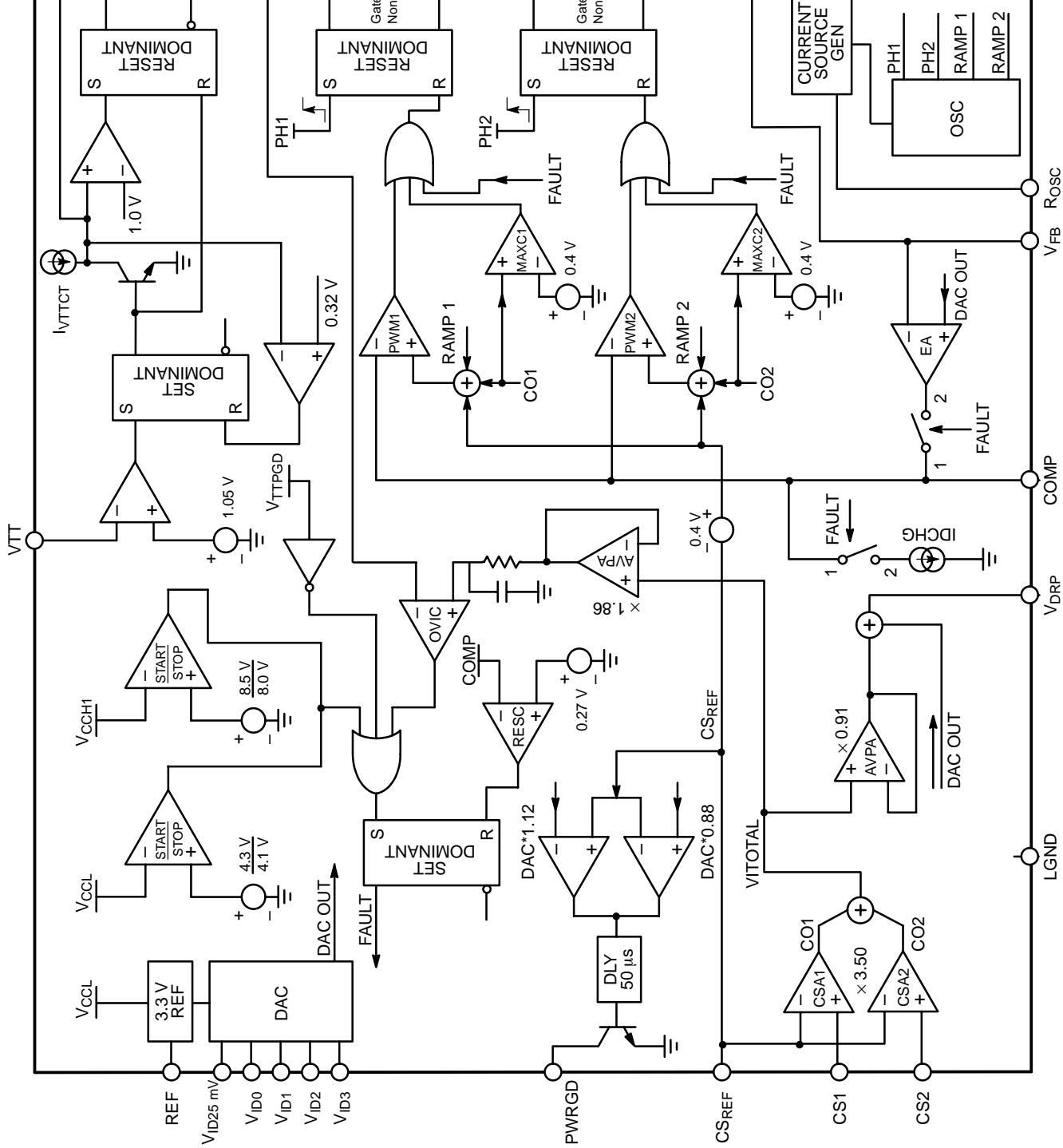


Figure 2. Block Diagram

TYPICAL PERFORMANCE CHARACTERISTICS

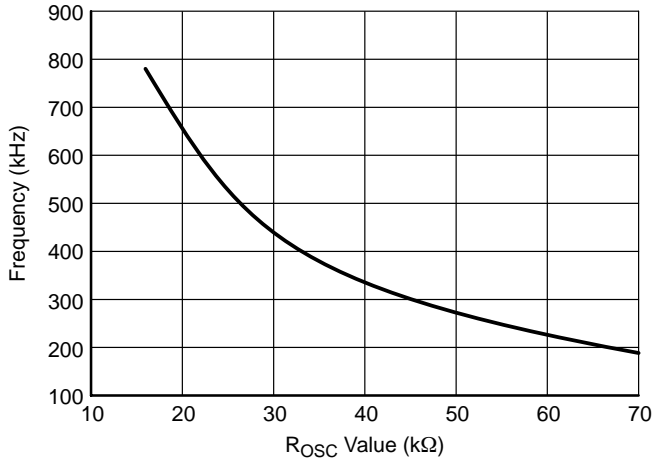


Figure 3. Oscillator Frequency vs. R<sub>osc</sub>

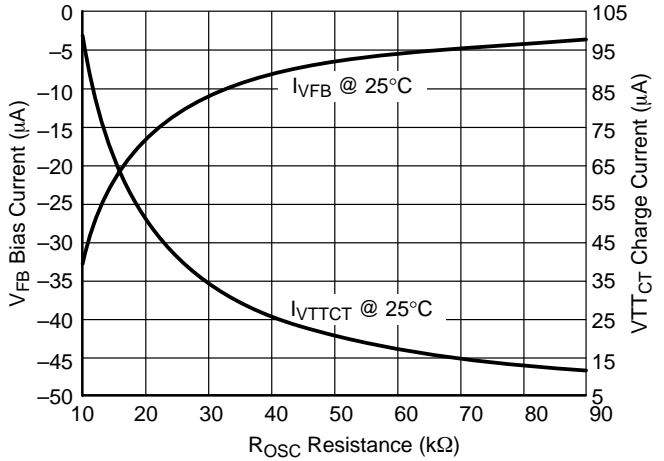


Figure 4. V<sub>FB</sub> & V<sub>TTCT</sub> Currents vs. R<sub>osc</sub> Value

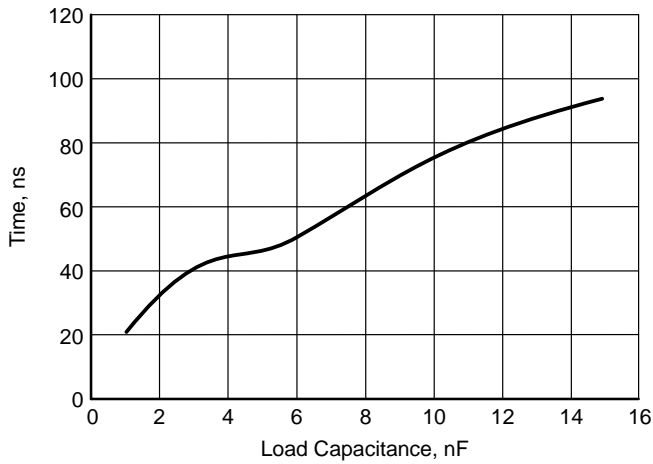


Figure 5. GATE(H) Rise Time vs. Load Capacitance Measured from 4.0 V to 1.0 V with V<sub>CC</sub> at 5.0 V

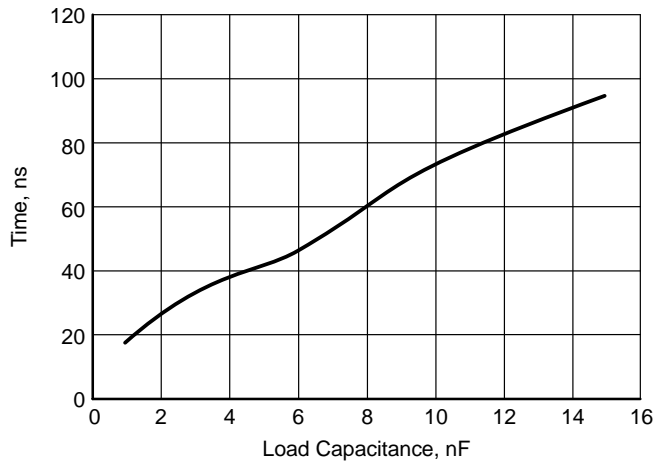


Figure 6. GATE(H) Fall Time vs. Load Capacitance Measured from 4.0 V to 1.0 V with V<sub>CC</sub> at 5.0 V

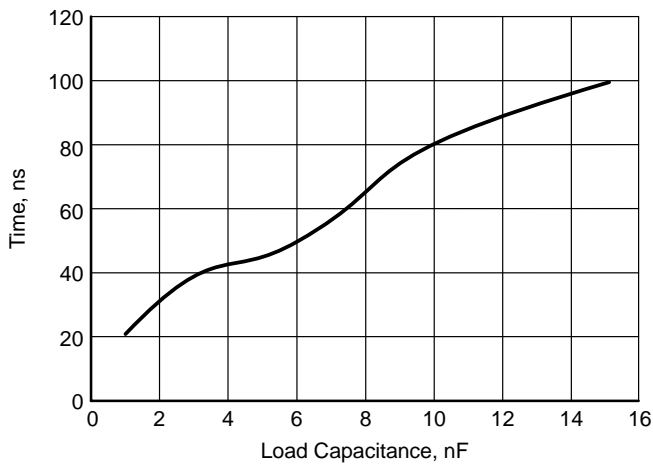


Figure 7. GATE(L) Rise Time vs. Load Capacitance Measured from 1.0 V to 4.0 V with V<sub>CC</sub> at 5.0 V

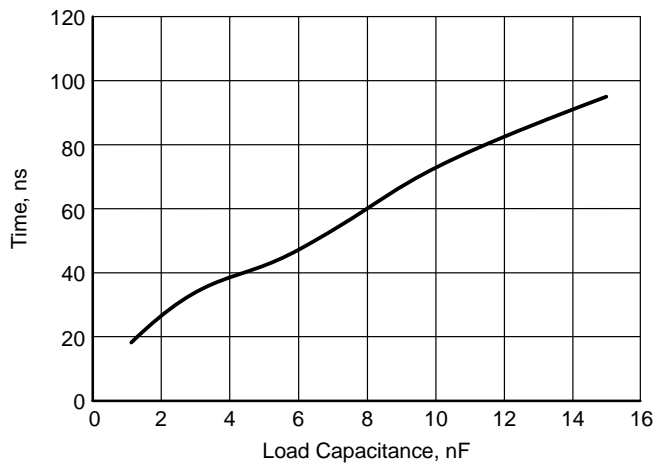


Figure 8. GATE(L) Fall Time vs. Load Capacitance Measured from 1.0 V to 4.0 V with V<sub>CC</sub> at 5.0 V

## APPLICATIONS INFORMATION

## Overview

The CS5308 DC/DC controller from ON Semiconductor was developed using the Enhanced  $V^2$  topology to meet requirements of low voltage, high current loads with fast transient requirements. Enhanced  $V^2$  combines the original  $V^2$  topology with peak current-mode control for fast transient response and current sensing capability. The addition of an internal PWM ramp and implementation of fast-feedback directly from  $V_{CORE}$  has improved transient response and simplified design. The CS5308 includes  $V_{TT}$  monitoring,  $V_{TTPGD}$ ,  $PWRGD$ , and MOSFET gate drivers to provide a “fully integrated solution” to simplify design, minimize circuit board area, and reduce overall system cost.

Two advantages of a multi-phase converter over a single-phase converter are current sharing and increased apparent output frequency. Current sharing allows the designer to use less inductance in each phase than would be required in a single-phase converter. The smaller inductor will produce larger ripple currents but the total per phase power dissipation is reduced because the RMS current is lower. Transient response is improved because the control loop will measure and adjust the current faster in a smaller output inductor. Increased apparent output frequency is desirable because the off-time and the ripple voltage of the two-phase converter will be less than that of a single-phase converter.

## Fixed Frequency Multi-Phase Control

In a multi-phase converter, multiple converters are connected in parallel and are switched on at different times. This reduces output current from the individual converters and increases the apparent ripple frequency. Because several converters are connected in parallel, output current can ramp up or down faster than a single converter (with the same value output inductor) and heat is spread among multiple components.

The CS5308 controller uses two-phase, fixed frequency, Enhanced  $V^2$  architecture to measure and control currents in

individual phases. Each phase is delayed  $180^\circ$  from the previous phase. Normally, GATE(H) transitions to a high voltage at the beginning of each oscillator cycle. Inductor current ramps up until the combination of the current sense signal, the internal ramp and the output voltage ripple trip the PWM comparator and bring GATE(H) low. Once GATE(H) goes low, it will remain low until the beginning of the next oscillator cycle. While GATE(H) is high, the Enhanced  $V^2$  loop will respond to line and load variations. On the other hand, once GATE(H) is low, the loop can not respond until the beginning of the next PWM cycle. Therefore, constant frequency Enhanced  $V^2$  will typically respond to disturbances within the off-time of the converter.

The Enhanced  $V^2$  architecture measures and adjusts the output current in each phase. An additional input (CSn) for inductor current information has been added to the  $V^2$  loop for each phase as shown in Figure 9. The triangular inductor current is measured differentially across  $R_{Sn}$ , amplified by CSA and summed with the Channel Startup Offset, the Internal Ramp, and the Output Voltage at the non-inverting input of the PWM comparator. The purpose of the Internal Ramp is to compensate for propagation delays in the CS5308. This provides greater design flexibility by allowing smaller external ramps, lower minimum pulse widths, higher frequency operation, and PWM duty cycles above 50% without external slope compensation. As the sum of the inductor current and the internal ramp increase, the voltage on the positive pin of the PWM comparator rises and terminates the PWM cycle. If the inductor starts a cycle with higher current, the PWM cycle will terminate earlier providing negative feedback. The CS5308 provides a CSn input for each phase, but the  $CS_{REF}$  and COMP inputs are common to all phases. Current sharing is accomplished by referencing all phases to the same  $CS_{REF}$  and COMP pins, so that a phase with a larger current signal will turn off earlier than a phase with a smaller current signal.

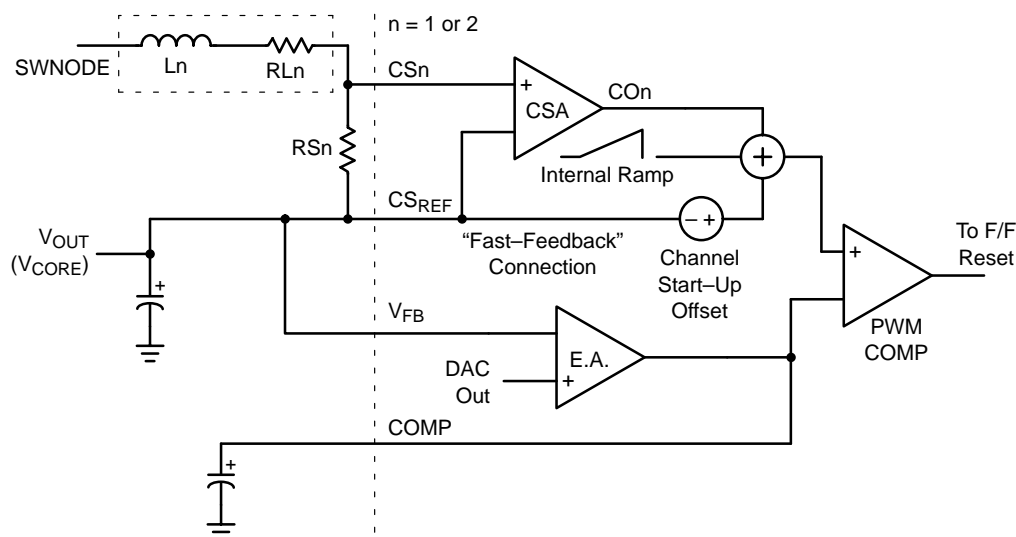


Figure 9. Enhanced  $V^2$  Control Employing Resistive Current Sensing and Additional Internal Ramp

Enhanced  $V^2$  responds to disturbances in  $V_{CORE}$  by employing both “slow” and “fast” voltage regulation. The internal error amplifier performs the slow regulation. Depending on the gain and frequency compensation set by the amplifier’s external components, the error amplifier will typically begin to ramp its output to react to changes in the output voltage in 1–2 PWM cycles. Fast voltage feedback is implemented by a direct connection from  $V_{CORE}$  to the non-inverting pin of the PWM comparator via the summation with the inductor current, internal ramp, and OFFSET. A rapid increase in load current will produce a negative offset at  $V_{CORE}$  and at the output of the summer. This will cause the PWM duty cycle to increase almost instantly. Fast feedback will typically adjust the PWM duty-cycle in one PWM cycle.

As shown in Figure 9, a “partial” internal ramp (nominally 125 mV at a 50% duty cycle) is added to the inductor current ramp at the positive terminal of the PWM comparator. This additional ramp compensates for propagation time delays from the current sense amplifier (CSA), the PWM comparator, and the MOSFET gate drivers. As a result, the minimum ON time of the controller is reduced and lower duty cycles may be achieved at higher frequencies. Also, the additional ramp reduces the reliance on the inductor current ramp and allows greater flexibility when choosing the output inductor and the  $R_{CSn}C_{CSn}$  ( $n = 1$  or  $2$ ) time constant of the feedback components from  $V_{CORE}$  to the CSn pin.

Including both current and voltage information in the feedback signal allows the open loop output impedance of the power stage to be controlled. When the average output current is zero, the COMP pin will be:

$$V_{COMP} = V_{OUT} @ 0 A + Channel\_Startup\_Offset + Int\_Ramp + G_{CSA} \cdot Ext\_Ramp/2$$

Int\_Ramp is the “partial” internal ramp value at the corresponding duty cycle, Ext\_Ramp is the peak-to-peak external steady-state ramp at 0 A,  $G_{CSA}$  is the Current Sense Amplifier Gain (nominally 3.5 V/V), and the Channel Startup Offset is typically 0.40 V. The magnitude of the Ext\_Ramp can be calculated from:

$$Ext\_Ramp = D \cdot (V_{IN} - V_{OUT}) / (R_{CSn} \cdot C_{CSn} \cdot f_{SW})$$

For example, if  $V_{OUT}$  at 0 A is set to 1.745 V with AVP and the input voltage is 5.0 V, the duty cycle (D) will be 1.745/5.0 or 35%. Int\_Ramp will be 125 mV • 35/50 = 87.5 mV. Realistic values for  $R_{CSn}$ ,  $C_{CSn}$  and  $f_{SW}$  are 60 k $\Omega$ , 0.01  $\mu$ F, and 300 kHz – using these Ext\_Ramp will be 6.3 mV.

$$\begin{aligned} V_{COMP} &= 1.745 V + 0.40 V + 87.5 mV \\ &\quad + 3.5 V/V \cdot 6.3 mV/2 \\ &= 2.244 Vdc. \end{aligned}$$

If the COMP pin is held steady and the inductor current changes, there must also be a change in the output voltage.

Or, in a closed loop configuration when the output current changes, the COMP pin must move to keep the same output voltage. The required change in the output voltage or COMP pin depends on the scaling of the current feedback signal and is calculated as:

$$\Delta V = R_S \cdot G_{CSA} \cdot \Delta I_{OUT}$$

The single-phase power stage output impedance is:

$$Single\ Stage\ Impedance = \Delta V_{OUT} / \Delta I_{OUT} = R_S \cdot G_{CSA}$$

The multi-phase power stage output impedance is the single-phase output impedance divided by the number of phases. The output impedance of the power stage determines how the converter will respond during the first few microseconds of a transient before the feedback loop has repositioned the COMP pin.

The peak output current can be calculated from:

$$I_{OUT,PEAK} = (V_{COMP} - V_{OUT} - Offset) / (R_S \cdot G_{CSA})$$

Figure 10 shows the step response of the COMP pin at a fixed level. Before T1 the converter is in normal steady state operation. The inductor current provides a portion of the PWM ramp through the Current Sense Amplifier. The PWM cycle ends when the sum of the current ramp, the “partial” internal ramp voltage signal and Offset exceed the level of the COMP pin. At T1 the output current increases and the output voltage sags. The next PWM cycle begins and the cycle continues longer than previously while the current signal increases enough to make up for the lower voltage at the  $V_{FB}$  pin and the cycle ends at T2. After T2 the output voltage remains lower than at light load and the average current signal level (CSn output) is raised so that the sum of the current and voltage signal is the same as with the original load. In a closed loop system the COMP pin would move higher to restore the output voltage to the original level.

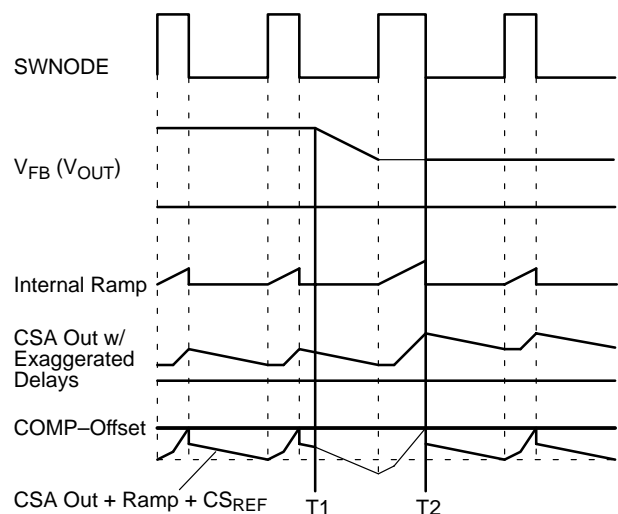


Figure 10. Open Loop Operation

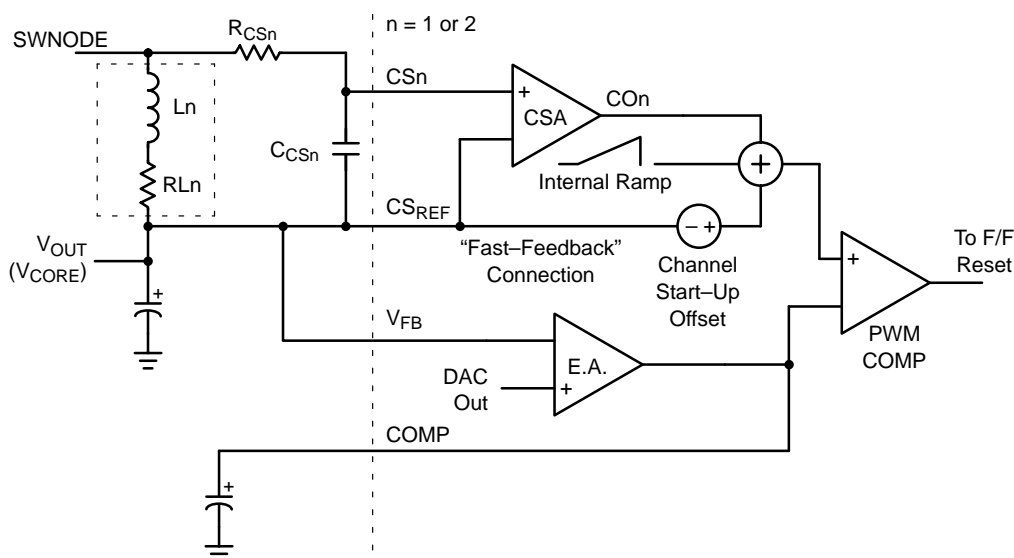


Figure 11. Enhanced  $V^2$  Control Employing Lossless Inductive Current Sensing and Internal Ramp

### Inductive Current Sensing

For lossless sensing, current can be sensed across the inductor as shown in Figure 11. In the diagram,  $L$  is the output inductance and  $R_L$  is the inherent inductor resistance. To compensate the current sense signal, the values of  $R_{CSn}$  and  $C_{CSn}$  are chosen so that  $L/R_L = R_{CSn} \cdot C_{CSn}$ . If this criteria is met, the current sense signal will be the same shape as the inductor current and the voltage signal at  $CS_n$  will represent the instantaneous value of inductor current. Also, the circuit can be analyzed as if a sense resistor of value  $R_L$  was used as a sense resistor ( $R_S$ ).

When choosing or designing inductors for use with inductive sensing, tolerances and temperature effects should be considered. Cores with a low permeability material or a large gap will usually have minimal inductance change with temperature and load. Copper magnet wire has a temperature coefficient of 0.39% per  $^{\circ}C$ . The increase in winding resistance at higher temperatures should be considered when setting the  $I_{LIM}$  threshold. If a more accurate current sense is required than inductive sensing can provide, current can be sensed through a resistor as shown in Figure 9.

### Current Sharing Accuracy

Printed circuit board (PCB) traces that carry inductor current can be used as part of the current sense resistance depending on where the current sense signal is picked off. For accurate current sharing, the current sense inputs should sense the current at relatively the same point for each phase and the connection to the  $CS_{REF}$  pin should be made so that no phase is favored. In some cases, especially with inductive sensing, resistance of the PCB can be useful for increasing the current sense resistance. The total current sense resistance used for calculations must include any PCB trace resistance between the  $CS_n$  input and the  $CS_{REF}$  input that carries inductor current.

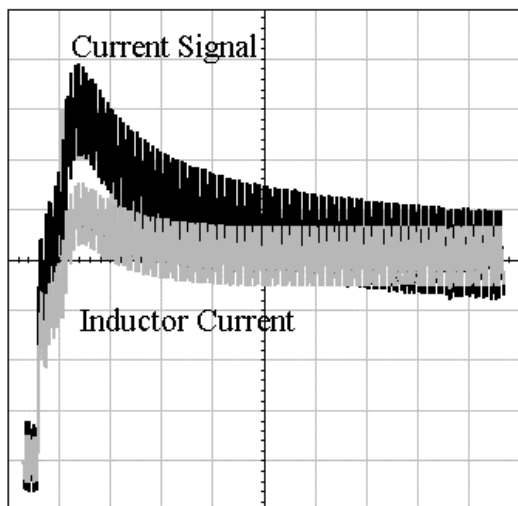
Current Sense Amplifier (CSA) input mismatch and the value of the current sense component will determine the accuracy of the current sharing between phases. The worst case Current Sense Amplifier input mismatch is  $\pm 5.0$  mV and will typically be within 3.0 mV. The difference in peak currents between phases will be the CSA input mismatch divided by the current sense resistance. If all current sense components are of equal resistance a 3.0 mV mismatch with a 2.0 m $\Omega$  sense resistance will produce a 1.5 A difference in current between phases.

### External Ramp Size and Current Sensing

The internal ramp allows flexibility of current sense time constant. Typically, the current sense  $R_{CSn}C_{CSn}$  time constant ( $n = 1$  or  $2$ ) should be equal to or slower than the inductor's time constant. If  $RC$  is chosen to be smaller (faster) than  $L/R_L$ , the AC or transient portion of the current sensing signal will be scaled larger than the DC portion. This will provide a larger steady state ramp, but circuit performance will be affected and must be evaluated carefully. The current signal will overshoot during transients and settle at the rate determined by  $R_{CSn} \cdot C_{CSn}$ . It will eventually settle to the correct DC level, but the error will decay with the time constant of  $R_{CSn} \cdot C_{CSn}$ . If this error is excessive it will effect transient response, adaptive positioning and current limit. During a positive current transient, the COMP pin will be required to overshoot in response to the current signal in order to maintain the output voltage. Similarly, the  $V_{DRP}$  signal will overshoot which will produce too much transient droop in the output voltage. Single phase overcurrent will trip earlier than it would if compensated correctly and hiccup mode current limit will have a lower threshold for fast rise step loads than for slowly rising output currents.

The waveforms in Figure 12 show a simulation of the current sense signal and the actual inductor current during

a positive step in load current with values of  $L = 500$  nH,  $R_L = 1.6$  m $\Omega$ ,  $R_{CSn} = 20$  k and  $C_{CSn} = 0.01$   $\mu$ F. For ideal current signal compensation the value of  $R_{CSn}$  should be 31 k $\Omega$ . Due to the faster than ideal RC time constant there is an overshoot of 50% and the overshoot decays with a 200  $\mu$ s time constant. With this compensation the  $I_{LIM}$  pin threshold must be set more than 50% above the full load current to avoid triggering hiccup mode during a large output load step.



**Figure 12. Inductive Sensing Waveform During a Load Step with Fast RC Time Constant (50  $\mu$ s/div)**

### Current Limit

Two levels of over-current protection are provided. First, if the voltage on the Current Sense pins (either CS1 or CS2) exceeds  $CS_{REF}$  by more than a fixed threshold (Single Pulse Current Limit), the PWM comparator is turned off. This provides fast peak current protection for individual phases. Second, the individual phase currents are summed and low-pass filtered to compare an averaged current signal to a user adjustable voltage on the  $I_{LIM}$  pin. If the  $I_{LIM}$  voltage is exceeded, the fault latch trips and the Soft Start capacitor is discharged until the COMP pin reaches 0.27 V. Then Soft Start begins. The converter will continue to operate in a low current hiccup mode until the fault condition is corrected.

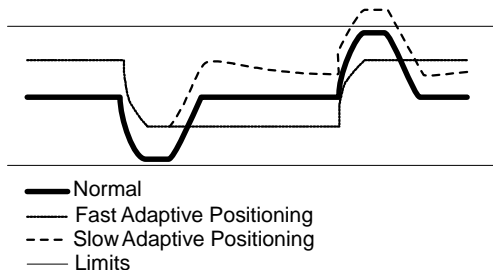
### Overvoltage Protection

Overvoltage protection (OVP) is provided as a result of the normal operation of the Enhanced  $V^2$  control topology with synchronous rectifiers. The control loop responds to an overvoltage condition within 400 ns, causing the top MOSFET to shut OFF and the synchronous (lower) MOSFET to turn ON. This results in a “crowbar” action to clamp the output voltage and prevent damage to the load. The regulator will remain in this state until the overvoltage condition ceases or the input voltage is pulled low.

### Transient Response and Adaptive Positioning

For applications with fast transient currents the output filter is frequently sized larger than ripple currents require in order to reduce voltage excursions during load transients. Adaptive voltage positioning can reduce peak-peak output voltage deviations during load transients and allow for a smaller output filter. The output voltage can be set higher than nominal at light loads to reduce output voltage sag when the load current is applied. Similarly, the output voltage can be set lower than nominal during heavy loads to reduce overshoot when the load current is removed. For low current applications a droop resistor can provide fast accurate adaptive positioning. However, at high currents the loss in a droop resistor becomes excessive. For example; in a 50 A converter a 1 m $\Omega$  resistor to provide a 50 mV change in output voltage between no load and full load would dissipate 2.5 Watts.

Lossless adaptive positioning is an alternative to using a droop resistor, but must respond to changes in load current. Figure 13 shows how adaptive positioning works. The waveform labeled normal shows a converter without adaptive positioning. On the left, the output voltage sags when the output current is stepped up and later overshoots when current is stepped back down. With fast (ideal) adaptive positioning the peak to peak excursions are cut in half. In the slow adaptive positioning waveform the output voltage is not repositioned quickly enough after current is stepped up and the upper limit is exceeded.



**Figure 13. Adaptive Positioning**

The controller can be configured to adjust the output voltage based on the output current of the converter. (Refer to the application diagram in Figure 1.) To set the no-load positioning, a resistor is placed between the output voltage and  $V_{FB}$  pin. The  $V_{FB}$  bias current will develop a voltage across the resistor to adjust the no-load output voltage. The  $V_{FB}$  bias current is dependent on the value of  $R_{OSC}$  as shown in the data sheets.

During no-load conditions the  $V_{DRP}$  pin is at the same voltage as the  $V_{FB}$  pin, so none of the  $V_{FB}$  bias current flows through the  $V_{DRP}$  resistor. When output current increases the  $V_{DRP}$  pin increases proportionally and the  $V_{DRP}$  pin current offsets the  $V_{FB}$  bias current and causes the output voltage to decrease.

The response during the first few microseconds of a load transient are controlled primarily by power stage output impedance and the ESR and ESL of the output filter. The transition between fast and slow positioning is controlled by the total ramp size and the error amp compensation. If the current signal is too large or the error amp too slow there will be a long transition to the final voltage after a transient. This will be most apparent with lower capacitance output filters.

### Error Amp Compensation & Tuning

The transconductance error amplifier requires a capacitor ( $C_{CMP2}$  in the Applications Diagram) between the COMP pin and GND for two reasons. First, this capacitor stabilizes the transconductance error amplifier. Values less than a few nF may cause oscillations of the COMP voltage. These oscillations will increase the output voltage jitter. Second, this capacitor sets the Soft Start time when power is applied to the converter or the converter is enabled. The internal error amplifier will source approximately 30  $\mu$ A during Soft Start and no switching will occur until the COMP voltage exceeds the Channel Startup Offset (nominally 0.4 V). The COMP voltage will ramp up to the value shown previously (repeated here for convenience):

$$V_{COMP} = V_{OUT} @ 0 A + \text{Channel\_Startup\_Offset} \\ + \text{Int\_Ramp} + G_{CSA} \cdot \text{Ext\_Ramp}/2$$

The RC network between the COMP pin and the Soft Start capacitor ( $R_{CMP1}$  and  $C_{CMP1}$ ) allows the COMP voltage to slew quickly during transient loading of the converter. Without this network the error amplifier would have to drive the large Soft Start/Stability capacitor directly, which would drastically limit the slew rate of the COMP voltage. The  $R_{CMP1}/C_{CMP1}$  network allows the COMP voltage to undergo a step change in voltage of approximately  $R_{CMP1} \cdot I_{COMP}$ .

The capacitor ( $C_{AMP}$ ) between the COMP pin and the inverting error amplifier input (the  $V_{FB}$  pin) and the parallel combination of the resistors  $R_{FBK1}$  and  $R_{DRP1}$  determine the bandwidth of the error amplifier. The gain of the error amplifier crosses 0 dB at a high enough frequency to give a quick transient response, but well below the switching frequency to minimize ripple and noise on the COMP pin. A capacitor in parallel with the  $V_{FB}$  resistor ( $C_{FBK2}$ ) adds a zero to boost phase near the crossover frequency to improve loop stability.

Setting-up and tuning the error amplifier is a three step process. First, the no-load and full-load adaptive voltage positioning (AVP) are set using  $R_{FBK1}$  and  $R_{DRP1}$ , respectively. Second, the current sense time constant and error amplifier gain are adjusted with  $R_{CSn}$  and  $C_{AMP}$  while monitoring  $V_{OUT}$  during transient loading. Lastly, the peak-to-peak voltage ripple on the COMP pin is examined when the converter is fully loaded to insure low output voltage jitter. The details of this process are covered in the Design Procedure section.

### Undervoltage Lockout (UVLO)

The controller has undervoltage lockout functions connected to two pins. One, intended for the logic and low-side drivers, with approximately a 4.2 V turn-on threshold is connected to the  $V_{CC}$  pin. A second, for the high side drivers, with approximately an 8.25 V threshold, is connected to the  $V_{CCH}$  pin.

The UVLO threshold for the high side drivers varies with the part type. In many applications this function will be disabled or will only check that the applicable supply is on – not that is at a high enough voltage to run the converter. See individual data sheets for more information on UVLO.

### Soft Start Enable, and Hiccup Mode

A capacitor between the COMP pin and GND controls Soft Start and hiccup mode slopes. A 0.1  $\mu$ F capacitor with the 30  $\mu$ A charge current will allow the output to ramp up at 0.3 V/ms or 1.5 V in 5 ms at start-up.

When a fault is detected due to an overcurrent condition the converter will enter a low duty cycle hiccup mode. During hiccup mode the converter will not switch from the time a fault is detected until the Soft Start capacitor has discharged below the Soft Start Discharge Threshold and then charged back up above the Channel Start Up Offset.

The COMP pin will disable the converter when pulled below 0.27 V

### VTT Monitoring & VTT Power Good (VTT<sub>PGD</sub>)

The CS5308 includes VTT monitoring, delay timing and an open-collector VTT Power Good (VTT<sub>PGD</sub>) output. A comparator with a threshold of approximately 1.05 V monitors VTT. At power-up, VTT<sub>PGD</sub> is held low and is released a short time after VTT crosses the 1.05 V threshold. The time between VTT stabilizing and the release of VTT<sub>PGD</sub> is set by a capacitor ( $C_{VTT}$ ) at the open-collector VTT<sub>CT</sub> pin. The voltage at the VTT<sub>CT</sub> pin will ramp from its  $V_{CE(sat)}$  voltage, approximately 0.25 V, to 1 V before VTT<sub>PGD</sub> is pulled HIGH. The VTT<sub>CT</sub> charging current and  $C_{VTT}$  set the VTT<sub>PGD</sub> delay time. The delay time can be calculated using:

$$T_{D,VTT} = (1 V - 0.25 V) \cdot C_{VTT}/VTT_{CT\_Current}$$

The VTT<sub>CT</sub> charging current is dependent on the selection of the oscillator frequency. See Figure 3 for a representation of oscillator frequency and charging current versus  $R_{OSC}$  value.

If either VTT or VTT<sub>PGD</sub> are held LOW, the internal Fault latch will be SET, the controller will stop switching, and  $V_{CORE}$  will be zero.

### Power Good (PWRGD)

The open-collector Power Good (PWRGD) pin is driven by a “window-comparator” monitoring  $V_{CORE}$ . This comparator will transition HIGH if  $V_{CORE}$  is within  $\pm 12\%$  of the nominal VID setting. After a 50  $\mu$ s delay, the comparators output will saturate the open-collector output transistor and the PWRGD pin will be pulled LOW.

### Layout Guidelines

With the fast rise, high output currents of microprocessor applications, parasitic inductance and resistance should be considered when laying out the power, filter and feedback signal sections of the board. Typically, a multi-layer board with at least one ground plane is recommended. If the layout is such that high currents can exist in the ground plane underneath the controller or control circuitry, the ground plane can be slotted to route the currents away from the controller. The slots should typically not be placed between the controller and the output voltage or in the return path of the gate drive. Additional power and ground planes or islands can be added as required for a particular layout.

Gate drives experience high di/dt during switching and the inductance of gate drive traces should be minimized. Gate drive traces should be kept as short and wide as practical and should have a return path directly below the gate trace.

Output filter components should be placed on wide planes connected directly to the load to minimize resistive drops during heavy loads and inductive drops and ringing during transients. If required, the planes for the output voltage and return can be interleaved to minimize inductance between the filter and load.

The current sense signals are typically tens of milli-volts. Noise pick-up should be avoided wherever possible. Current feedback traces should be routed away from noisy areas such as the switch node and gate drive signals. If the current signals are taken from a location other than directly at the inductor any additional resistance between the pick-off point and the inductor appears as part of the inherent inductor resistances and should be considered in design calculations. The capacitors for the current feedback networks should be placed as close to the current sense pins as practical. After placing the CS5308 control IC, follow these guidelines to optimize the layout and routing:

1. Place the 1  $\mu$ F power-supply bypass (ceramic) capacitors close to their associated pins:  $V_{CCL}$ ,  $V_{CCH1}$ ,  $V_{CCH2}$ ,  $V_{CCL12}$ .
2. Place the MOSFETs to minimize the length of the Gate traces. Orient the MOSFETs such that the Drain connections are away from the controller and the Gate connections are closest to the controller.
3. Place the components associated with the internal error amplifier ( $R_{FBK1}$ ,  $C_{FBK2}$ ,  $C_{AMP}$ ,  $R_{CMP1}$ ,  $C_{CMP1}$ ,  $C_{CMP2}$ ,  $R_{DRP1}$ ) to minimize the trace lengths to the pins  $V_{FB}$ ,  $V_{DRP}$  and COMP.
4. Place the current sense components ( $R_{CS1}$ ,  $R_{CS2}$ ,  $C_{CS1}$ ,  $C_{CS2}$ ,  $R_{CSREF}$ ,  $C_{CSREF}$ ) near the CS1, CS2, and  $CS_{REF}$  pins.
5. Place the frequency setting resistor ( $R_{OSC}$ ) close to the  $R_{OSC}$  pin. The  $R_{OSC}$  pin is very sensitive to noise. Route noisy traces, such as the SWNODEs and GATE traces, away from the  $R_{OSC}$  pin and resistor.
6. Place the VTT timing capacitor ( $C_{VTT}$ ) and pull-up resistor ( $R_{VTT}$ ) near the  $VTT_{CT}$  and  $VTT_{PGD}$  pins.

7. Place the MOSFETs and output inductors to reduce the size of the noisy SWNODEs. There is a trade-off between reducing the size of the SWNODEs for noise reduction and providing adequate heat-sinking for the synchronous MOSFETs.
8. Place the input inductor and input capacitor(s) near the Drain of the control (upper) MOSFETs. There is a trade-off between reducing the size of this node to save board area and providing adequate heat-sinking for the control MOSFETs.
9. Place the output capacitors (electrolytic and ceramic) close to the processor socket or output connector.
10. The trace from the SWNODEs to the current sense components will be very noisy. Route this away from more sensitive, low-level traces. The Ground layer can be used to help isolate this trace.
11. The Gate traces are very noisy. Route these away from more sensitive, low-level traces. Keep each Gate signal on one layer and insure that there is an uninterrupted return path directly below the Gate trace. The Ground layer can be used to help isolate these traces.
12. Don't "daisy chain" connections to Ground from one via. Allow each connection to Ground to have its own via as close to the component as possible.
13. Use a slot in the ground plane from the bulk output capacitors back to the input power connector to prevent high currents from flowing beneath the control IC. This slot should extend length-wise under the control IC and separate the connections to "signal ground" and "power ground." Examples of signal ground include the capacitors at COMP,  $CS_{REF}$ , REF, and  $VTT_{CT}$ , the resistors at  $R_{OSC}$  and  $I_{LIM}$ , and the LGND pin to the controller. Examples of power ground include the capacitors to  $V_{CCH1}$ ,  $V_{CCH2}$  and  $V_{CCL12}$ , the Source of the synchronous MOSFETs, and the PGND pin to the controller.
14. The  $CS_{REF}$  sense point should be equidistant between the output inductors to equalize the PCB resistance added to the current sense paths. This will insure acceptable current sharing. Also, route the  $CS_{REF}$  connection away from noisy traces such as the SWNODEs and GATE traces. If noise from the SWNODEs or GATE signals capacitively couples to the  $CS_{REF}$  trace the external ramps will be very noise and voltage jitter will result.
15. Ideally, the SWNODEs are exactly the same shape and the current sense points (connections to  $R_{CS1}$  and  $R_{CS2}$ ) are made at identical locations to equalize the PCB resistance added to the current sense paths. This will help to insure acceptable current sharing.
16. Place the 0.1  $\mu$ F ceramic capacitors,  $C_{Q1}$  and  $C_{Q2}$ , close to the drains of the MOSFETs Q1 and Q2, respectively.

## Design Procedure

### 1. Output Capacitor Selection

The output capacitors filter the current from the output inductor and provide a low impedance for transient load current changes. Typically, microprocessor applications will require both bulk (electrolytic, tantalum) and low impedance, high frequency (ceramic) types of capacitors. The bulk capacitors provide “hold up” during transient loading. The low impedance capacitors reduce steady-state ripple and bypass the bulk capacitance when the output current changes very quickly. The microprocessor manufacturers usually specify a minimum number of ceramic capacitors. The designer must determine the number of bulk capacitors.

Choose the number of bulk output capacitors to meet the peak transient requirements. The formula below can be used to provide a starting point for the minimum number of bulk capacitors ( $N_{OUT,MIN}$ ):

$$N_{OUT,MIN} = \text{ESR per capacitor} \cdot \frac{\Delta I_{O,MAX}}{\Delta V_{O,MAX}} \quad (1)$$

In reality, both the ESR and ESL of the bulk capacitors determine the voltage change during a load transient according to:

$$\Delta V_{O,MAX} = (\Delta I_{O,MAX}/\Delta t) \cdot \text{ESL} + \Delta I_{O,MAX} \cdot \text{ESR} \quad (2)$$

Unfortunately, capacitor manufacturers do not specify the ESL of their components and the inductance added by the PCB traces is highly dependent on the layout and routing. Therefore, it is necessary to start a design with slightly more than the minimum number of bulk capacitors and perform transient testing or careful modeling/simulation to determine the final number of bulk capacitors.

### 2. Output Inductor Selection

The output inductor may be the most critical component in the converter because it will directly effect the choice of other components and dictate both the steady-state and transient performance of the converter. When selecting an inductor the designer must consider factors such as DC current, peak current, output voltage ripple, core material, magnetic saturation, temperature, physical size, and cost (usually the primary concern).

In general, the output inductance value should be as low and physically small as possible to provide the best transient response and minimum cost. If a large inductance value is used, the converter will not respond quickly to rapid changes in the load current. On the other hand, too low an inductance value will result in very large ripple currents in the power components (MOSFETs, capacitors, etc.) resulting in increased dissipation and lower converter efficiency. Also, increased ripple currents will force the designer to use higher rated MOSFETs, oversize the thermal solution, and use more, higher rated input and output capacitors – the converter cost will be adversely effected.

One method of calculating an output inductor value is to size the inductor to produce a specified maximum ripple current in the inductor. Lower ripple currents will result in less core and MOSFET losses and higher converter efficiency. Equation 3 may be used to calculate the minimum inductor value to produce a given maximum ripple current ( $\alpha$ ) per phase. The inductor value calculated by this equation is a minimum because values less than this will produce more ripple current than desired. Conversely, higher inductor values will result in less than the maximum ripple current.

$$L_{O,MIN} = \frac{(V_{IN} - V_{OUT}) \cdot V_{OUT}}{(\alpha \cdot I_{O,MAX} \cdot V_{IN} \cdot f_{SW})} \quad (3)$$

$\alpha$  is the ripple current as a percentage of the maximum output current *per phase* ( $\alpha = 0.15$  for  $\pm 15\%$ ,  $\alpha = 0.25$  for  $\pm 25\%$ , etc.). If the minimum inductor value is used, the inductor current will swing  $\pm \alpha\%$  about its value at the center (1/2 the DC output current for a two-phase converter). Therefore, for a two-phase converter, the inductor must be designed or selected such that it will not saturate with a peak current of  $(1 + \alpha) \cdot I_{O,MAX}/2$ .

The maximum inductor value is limited by the transient response of the converter. If the converter is to have a fast transient response then the inductor should be made as small as possible. If the inductor is too large its current will change too slowly, the output voltage will droop excessively, more bulk capacitors will be required, and the converter cost will be increased. For a given inductor value, its interesting to determine the times required to increase or decrease the current.

For increasing current:

$$\Delta t_{INC} = L_o \cdot \Delta I_O / (V_{IN} - V_{OUT}) \quad (3.1)$$

For decreasing current:

$$\Delta t_{DEC} = L_o \cdot \Delta I_O / (V_{OUT}) \quad (3.2)$$

For typical processor applications with output voltages less than half the input voltage, the current will be increased much more quickly than it can be decreased. It may be more difficult for the converter to stay within the regulation limits when the load is removed than when it is applied – excessive overshoot may result.

The output voltage ripple can be calculated using the output inductor value derived in this Section ( $L_{O,MIN}$ ), the number of output capacitors ( $N_{OUT,MIN}$ ) and the per capacitor ESR determined in the previous Section:

$$V_{OUT,P-P} = (\text{ESR per cap} / N_{OUT,MIN}) \cdot \{(V_{IN} - \#Phases \cdot V_{OUT}) \cdot D / (L_{O,MIN} \cdot f_{SW})\} \quad (4)$$

This formula assumes steady-state conditions with no more than one phase on at any time. The second term in Equation 4 is the total ripple current seen by the output capacitors. The total output ripple current is the “time

summation” of the two individual phase currents that are 180 degrees out-of-phase. As the inductor current in one phase ramps upward, current in the other phase ramps downward and provides a canceling of currents during part of the switching cycle. Therefore, the total output ripple current and voltage are reduced in a multi-phase converter.

### 3. Input Capacitor Selection

The choice and number of input capacitors is primarily determined by their voltage and ripple current ratings. The designer must choose capacitors that will support the worst case input voltage with adequate margin. To calculate the number of input capacitors one must first determine the total RMS input ripple current. To this end, begin by calculating the average input current to the converter:

$$I_{IN,AVG} = I_{O,MAX} \cdot D/\eta \quad (5)$$

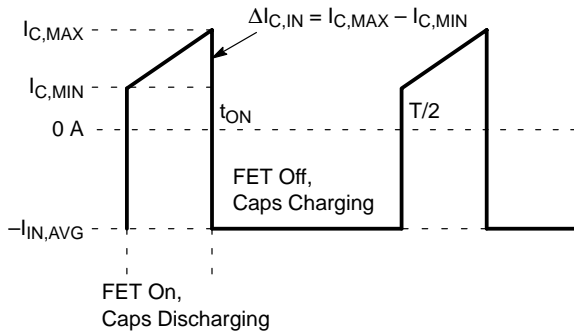
where:

D is the duty cycle of the converter,  $D = V_{OUT}/V_{IN}$ ;

$\eta$  is the specified minimum efficiency;

$I_{O,MAX}$  is the maximum converter output current.

The input capacitors will discharge when the control FET is ON and charge when the control FET is OFF as shown in Figure 14.



**Figure 14. Input Capacitor Current for a Two-Phase Converter**

The following equations will determine the maximum and minimum currents delivered by the input capacitors:

$$I_{C,MAX} = I_{L_O,MAX}/\eta - I_{IN,AVG} \quad (6)$$

$$I_{C,MIN} = I_{L_O,MIN}/\eta - I_{IN,AVG} \quad (7)$$

$I_{L_O,MAX}$  is the maximum output inductor current:

$$I_{L_O,MAX} = I_{O,MAX}/2 + \Delta I_{L_O}/2 \quad (8)$$

$I_{L_O,MIN}$  is the minimum output inductor current:

$$I_{L_O,MIN} = I_{O,MAX}/2 - \Delta I_{L_O}/2 \quad (9)$$

$\Delta I_{L_O}$  is the peak-to-peak ripple current in the output inductor of value  $L_O$ :

$$\Delta I_{L_O} = (V_{IN} - V_{OUT}) \cdot D/(L_O \cdot f_{SW}) \quad (10)$$

For the two-phase converter, the input capacitor(s) RMS current is then:

$$I_{CIN,RMS} = [2D \cdot (I_{C,MIN}^2 + I_{C,MIN} \cdot \Delta I_{C,IN} + \Delta I_{C,IN}^2/3) + I_{IN,AVG}^2 \cdot (1 - 2D)]^{1/2} \quad (11)$$

Select the number of input capacitors ( $N_{IN}$ ) to provide the RMS input current ( $I_{CIN,RMS}$ ) based on the RMS ripple current rating per capacitor ( $I_{RMS,RATED}$ ):

$$N_{IN} = I_{CIN,RMS}/I_{RMS,RATED} \quad (12)$$

For a two-phase converter with perfect efficiency ( $\eta = 1$ ), the worst case input ripple-current will occur when the converter is operating at a 25% duty cycle. At this operating point, the parallel combination of input capacitors must support an RMS ripple current equal to 25% of the converter’s DC output current. At other duty cycles, the ripple-current will be less. For example, at a duty cycle of either 10% or 40%, the two-phase input ripple-current will be approximately 20% of the converter’s DC output current.

In general, capacitor manufacturers require derating to the specified ripple-current based on the ambient temperature. More capacitors will be required because of the current derating. The designer should be cognizant of the ESR of the input capacitors. The input capacitor power loss can be calculated from:

$$P_{CIN} = I_{CIN,RMS}^2 \cdot ESR_{per\_capacitor}/N_{IN} \quad (13)$$

Low ESR capacitors are recommended to minimize losses and reduce capacitor heating. The life of an electrolytic capacitor is reduced 50% for every 10°C rise in the capacitor’s temperature.

### 4. Input Inductor Selection

The use of an inductor between the input capacitors and the power source will accomplish two objectives. First, it will isolate the voltage source and the system from the noise generated in the switching supply. Second, it will limit the inrush current into the input capacitors at power up. Large inrush currents will reduce the expected life of the input capacitors. The inductor’s limiting effect on the input current slew rate becomes increasingly beneficial during load transients.

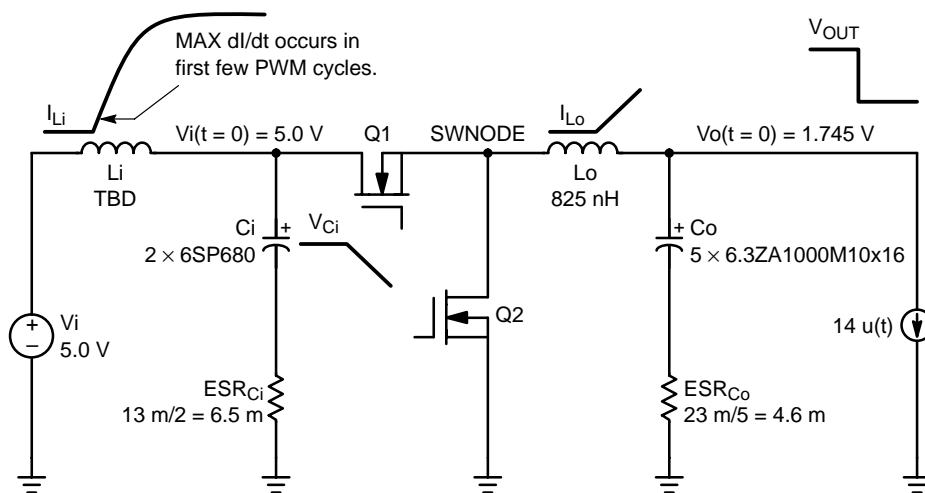


Figure 15. Calculating the Input Inductance

The worst case input current slew rate will occur during the first few PWM cycles immediately after a step-load change is applied as shown in Figure 15. When the load is applied, the output voltage is pulled down very quickly. Current through the output inductors will not change instantaneously so the initial transient load current must be conducted by the output capacitors. The output voltage will step downward depending on the magnitude of the output current ( $I_{O,MAX}$ ), the per capacitor ESR of the output capacitors ( $ESR_{OUT}$ ), and the number of the output capacitors ( $N_{OUT}$ ) as shown in Figure . Assuming the load current is shared equally between the two phases, the output voltage at full, transient load will be:

$$V_{OUT,FULL-LOAD} = V_{OUT,NO-LOAD} - (I_{O,MAX}/2) \cdot ESR_{OUT}/N_{OUT} \quad (14)$$

When the control MOSFET (Q1 in Figure 15) turns ON, the input voltage will be applied to the opposite terminal of the output inductor (the SWNODE). At that instant, the voltage across the output inductor can be calculated as:

$$\begin{aligned} \Delta V_{Lo} &= V_{IN} - V_{OUT,FULL-LOAD} \\ &= V_{IN} - V_{OUT,NO-LOAD} \\ &\quad + (I_{O,MAX}/2) \cdot ESR_{OUT}/N_{OUT} \end{aligned} \quad (15)$$

The differential voltage across the output inductor will cause its current to increase linearly with time. The slew rate of this current can be calculated from:

$$dI_{Lo}/dt = \Delta V_{Lo}/L_o \quad (16)$$

Current changes slowly in the input inductor so the input capacitors must initially deliver the vast majority of the input current. The amount of voltage drop across the input capacitors ( $\Delta V_{Ci}$ ) is determined by the number of input capacitors ( $N_{IN}$ ), their per capacitor ESR ( $ESR_{IN}$ ), and the current in the output inductor according to:

$$\begin{aligned} \Delta V_{Ci} &= ESR_{IN}/N_{IN} \cdot dI_{Lo}/dt \cdot t_{ON} \\ &= ESR_{IN}/N_{IN} \cdot dI_{Lo}/dt \cdot D/f_{SW} \end{aligned} \quad (17)$$

Before the load is applied, the voltage across the input inductor ( $V_{Li}$ ) is very small – the input capacitors charge to the input voltage,  $V_{IN}$ . After the load is applied the voltage drop across the input capacitors,  $\Delta V_{Ci}$ , appears across the input inductor as well. Knowing this, the minimum value of the input inductor can be calculated from:

$$\begin{aligned} L_{iMIN} &= V_{Li} / dI_{IN}/dt_{MAX} \\ &= \Delta V_{Ci} / dI_{IN}/dt_{MAX} \end{aligned} \quad (18)$$

$dI_{IN}/dt_{MAX}$  is the maximum allowable input current slew rate (specified as 0.1 A/ $\mu$ s or  $0.1 \times 10^6$  A/s for VRM 8.5).

The input inductance value calculated from Equation 18 is relatively conservative. It assumes the supply voltage is very “stiff” and does not account for any parasitic elements that will limit  $dI/dt$  such as stray inductance. Also, the ESR values of the capacitors specified by the manufacturer’s data sheets are worst case high limits. In reality input voltage “sag,” lower capacitor ESRs, and stray inductance will help reduce the slew rate of the input current.

As with the output inductor, the input inductor must support the maximum current without saturating the magnetic. Also, for an inexpensive iron powder core, such as the –26 or –52 from Micrometals, the inductance “swing” with DC bias must be taken into account – inductance will decrease as the DC input current increases. At the maximum input current, the inductance must not decrease below the minimum value or the  $dI/dt$  will be higher than expected.

## 5. MOSFET & Heatsink Selection

Power dissipation, package size, and thermal solution drive MOSFET selection. To adequately size the heat sink, the design must first predict the MOSFET power dissipation. Once the dissipation is known, the heat sink thermal impedance can be calculated to prevent the

specified maximum case or junction temperatures from being exceeded at the highest ambient temperature. Power dissipation has two primary contributors: conduction losses and switching losses. The control or upper MOSFET will display both switching and conduction losses. The synchronous or lower MOSFET will exhibit only conduction losses because it switches into nearly zero voltage. However, the body diode in the synchronous MOSFET will suffer diode losses during the non-overlap time of the gate drivers.

For the upper or control MOSFET, the power dissipation can be approximated from:

$$\begin{aligned}
 P_{D,CONTROL} &= (I_{RMS,CNTL}^2 \cdot R_{DS(on)}) & (19) \\
 &+ (I_{Lo,MAX} \cdot Q_{switch}/I_g \cdot V_{IN} \cdot f_{SW}) \\
 &+ (Q_{oss}/2 \cdot V_{IN} \cdot f_{SW}) + (V_{IN} \cdot Q_{RR} \cdot f_{SW})
 \end{aligned}$$

The first term represents the conduction or IR losses when the MOSFET is ON while the second term represents the switching losses. The third term is the losses associated with the *control and synchronous* MOSFET output charge when the control MOSFET turns ON. The output losses are caused by both the control and synchronous MOSFET but are dissipated only in the control FET. The fourth term is the loss due to the reverse recovery time of the body diode in the *synchronous* MOSFET. The first two terms are usually adequate to predict the majority of the losses.

Where  $I_{RMS,CNTL}$  is the RMS value of the trapezoidal current in the control MOSFET:

$$\begin{aligned}
 I_{RMS,CNTL} &= \sqrt{D} & (20) \\
 &\cdot [(I_{Lo,MAX}^2 + I_{Lo,MAX} \cdot I_{Lo,MIN} + I_{Lo,MIN}^2)/3]^{1/2}
 \end{aligned}$$

$I_{Lo,MAX}$  is the maximum output inductor current:

$$I_{Lo,MAX} = I_{O,MAX}/2 + \Delta I_{Lo}/2 \quad (21)$$

$I_{Lo,MIN}$  is the minimum output inductor current:

$$I_{Lo,MIN} = I_{O,MAX}/2 - \Delta I_{Lo}/2 \quad (22)$$

$I_{O,MAX}$  is the maximum converter output current.

D is the duty cycle of the converter:

$$D = V_{OUT}/V_{IN} \quad (23)$$

$\Delta I_{Lo}$  is the peak-to-peak ripple current in the output inductor of value  $L_o$ :

$$\Delta I_{Lo} = (V_{IN} - V_{OUT}) \cdot D/(L_o \cdot f_{SW}) \quad (24)$$

$R_{DS(on)}$  is the ON resistance of the MOSFET at the applied gate drive voltage.

$Q_{switch}$  is the post gate threshold portion of the gate-to-source charge plus the gate-to-drain charge. This

may be specified in the data sheet or approximated from the gate-charge curve as shown in the Figure 16.

$$Q_{switch} = Q_{gs2} + Q_{gd} \quad (25)$$

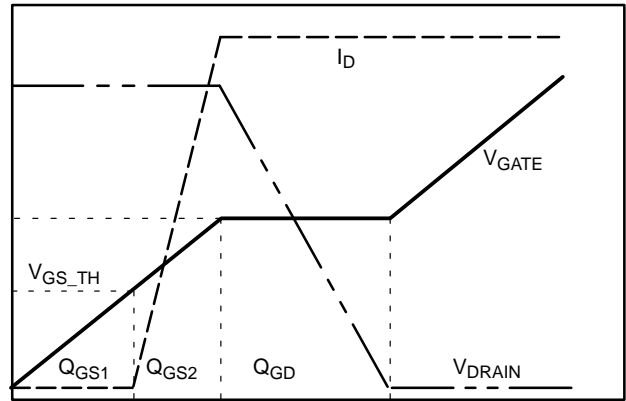


Figure 16. MOSFET Switching Characteristics

$I_g$  is the output current from the gate driver IC.

$V_{IN}$  is the input voltage to the converter.

$f_{sw}$  is the switching frequency of the converter.

$Q_G$  is the MOSFET total gate charge to obtain  $R_{DS(on)}$ .

Commonly specified in the data sheet.

$V_g$  is the gate drive voltage.

$Q_{RR}$  is the reverse recovery charge of the *lower* MOSFET.

$Q_{oss}$  is the MOSFET output charge specified in the data sheet.

For the lower or synchronous MOSFET, the power dissipation can be approximated from:

$$\begin{aligned}
 P_{D,SYNCH} &= (I_{RMS,SYNCH}^2 \cdot R_{DS(on)}) & (26) \\
 &+ (V_{fdiode} \cdot I_{O,MAX}/2 \cdot t_{nonoverlap} \cdot f_{SW})
 \end{aligned}$$

The first term represents the conduction or IR losses when the MOSFET is ON and the second term represents the diode losses that occur during the gate non-overlap time.

All terms were defined in the previous discussion for the control MOSFET with the exception of:

$$\begin{aligned}
 I_{RMS,SYNCH} &= \sqrt{1 - D} & (27) \\
 &\cdot [(I_{Lo,MAX}^2 + I_{Lo,MAX} \cdot I_{Lo,MIN} + I_{Lo,MIN}^2)/3]^{1/2}
 \end{aligned}$$

where:

$V_{fdiode}$  is the forward voltage of the MOSFET's intrinsic diode at the converter output current.

$t_{nonoverlap}$  is the non-overlap time between the upper and lower gate drivers to prevent cross conduction.

This time is usually specified in the data sheet for the control IC.



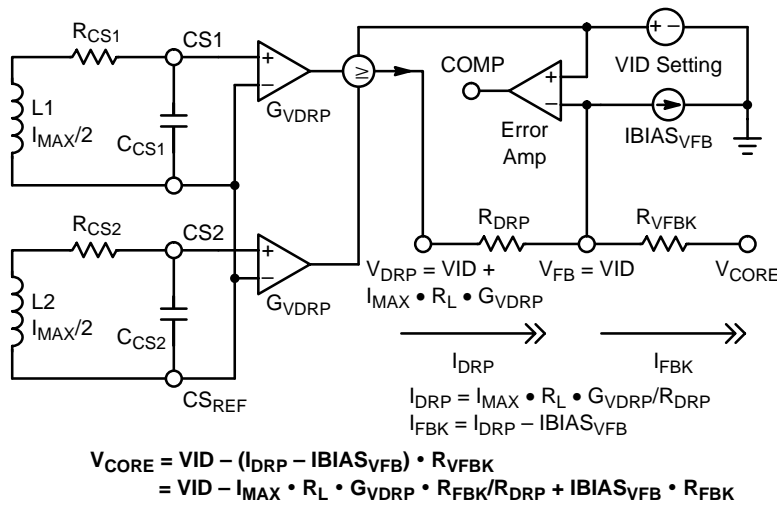


Figure 18. AVP Circuitry at Full-Load

To determine the value of  $R_{DRP}$  the designer must specify the full-load voltage reduction from the VID (DAC) setting ( $\Delta V_{OUT, FULL-LOAD}$ ) and predict the voltage increase at the  $V_{DRP}$  pin at full-load. Usually, the full-load voltage reduction is specified in the design guide for the processor that is available from the manufacturer. To predict the voltage increase at the  $V_{DRP}$  pin at full-load ( $\Delta V_{DRP}$ ), the designer must consider the output inductor’s resistance ( $R_L$ ), the PCB trace resistance between the current sense points ( $R_{PCB}$ ), and the controller IC’s gain from the current sense to the  $V_{DRP}$  pin ( $G_{VDRP}$ ):

$$\Delta V_{DRP} = I_{O, MAX} \cdot (R_L + R_{PCB}) \cdot G_{VDRP} \quad (30)$$

The value of  $R_{DRP}$  can then be calculated:

$$R_{DRP} = \frac{\Delta V_{DRP}}{(I_{BIAS_{VFB}} + \Delta V_{OUT, FULL-LOAD} / R_{VFBK})} \quad (31)$$

$\Delta V_{OUT, FULL-LOAD}$  is the full-load voltage reduction from the VID (DAC) setting.  $\Delta V_{OUT, FULL-LOAD}$  is *not* the voltage change from the no-load AVP setting.

### 7. Current Sensing

For inductive current sensing, choose the current sense network ( $R_{CSn}, C_{CSn}, n = 1 \text{ or } 2$ ) to satisfy

$$R_{CSn} \cdot C_{CSn} = L_o / (R_L + R_{PCB}) \quad (32)$$

For resistive current sensing, choose the current sense network ( $R_{CSn}, C_{CSn}, n = 1 \text{ or } 2$ ) to satisfy

$$R_{CSn} \cdot C_{CSn} = L_o / (R_{sense}) \quad (33)$$

This will provide an adequate starting point for  $R_{CSn}$  and  $C_{CSn}$ . After the converter is constructed, the value of  $R_{CSn}$  (and/or  $C_{CSn}$ ) should be fine-tuned in the lab by observing the  $V_{DRP}$  signal during a step change in load current. Tune

the  $R_{CSn} \cdot C_{CSn}$  network to provide a “square-wave” at the  $V_{DRP}$  output pin with maximum rise time and minimal overshoot as shown in Figure 21.

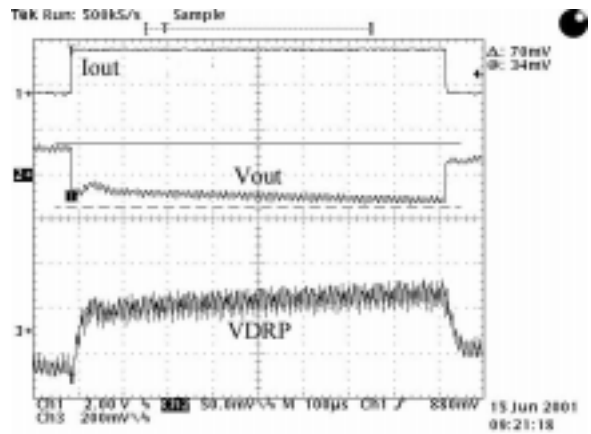


Figure 19.  $V_{DRP}$  Tuning Waveforms. The RC Time Constant of the Current Sense Network Is Too Long (Slow):  $V_{DRP}$  and  $V_{OUT}$  Respond Too Slowly.

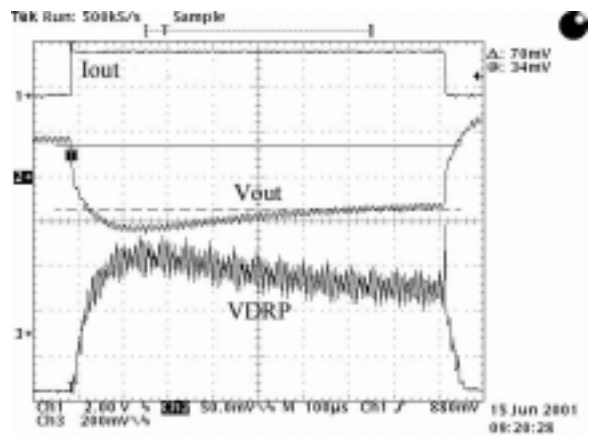
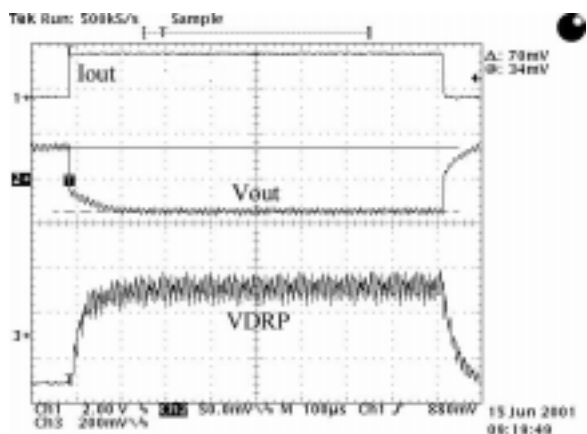


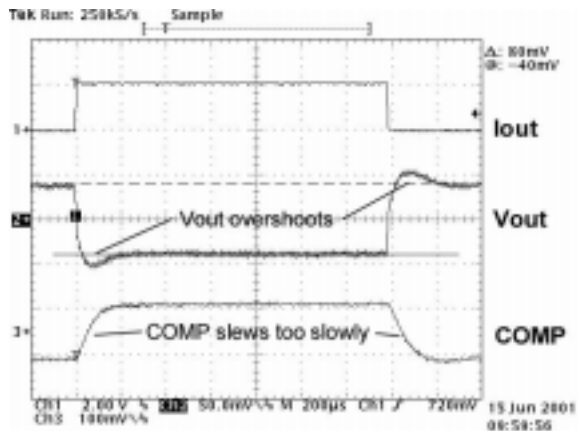
Figure 20.  $V_{DRP}$  Tuning Waveforms. The RC Time Constant of the Current Sense Network Is Too Short (Fast):  $V_{DRP}$  and  $V_{OUT}$  Both Overshoot.



**Figure 21.  $V_{DRP}$  Tuning Waveforms. The RC Time Constant of the Current Sense Network Is Optimal:  $V_{DRP}$  and  $V_{OUT}$  Respond to the Load Current Quickly Without Overshooting.**

### 8. Error Amplifier Tuning

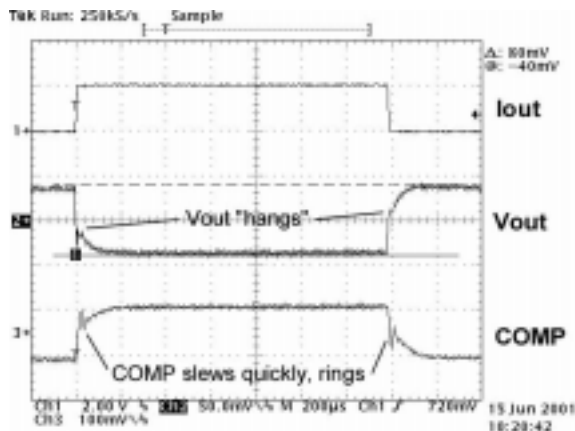
After the steady-state (static) AVP has been set and the current sense network has been optimized the Error Amplifier must be tuned. Basically, the gain of the Error Amplifier should be adjusted to provide an acceptable transient response by increasing or decreasing the Error Amplifier’s feedback capacitor ( $C_{AMP}$  in the Applications Diagram). The bandwidth of the control loop will vary directly with the gain of the error amplifier.



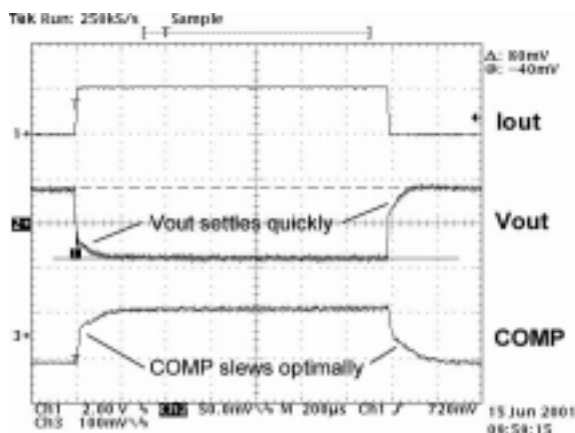
**Figure 22. The Value of  $C_{AMP}$  Is Too High and the Loop Gain/Bandwidth Too Low. COMP Slews Too Slowly Which Results in Overshoot in  $V_{OUT}$ .**

If  $C_{AMP}$  is too large the loop gain/bandwidth will be low, the COMP pin will slew too slowly, and the output voltage will overshoot as shown in Figure 22. On the other hand, if  $C_{AMP}$  is too small the loop gain/bandwidth will be high, the COMP pin will slew very quickly and overshoot. Integrator “wind up” is the cause of the overshoot. In this case the output voltage will transition more slowly because COMP

spikes upward as shown in Figure 23. Too much loop gain/bandwidth increase the risk of instability. In general, one should use the lowest loop gain/bandwidth as possible to achieve acceptable transient response – this will insure good stability. If  $C_{AMP}$  is optimal the COMP pin will slew quickly but not overshoot and the output voltage will monotonically settle as shown in Figure 24.

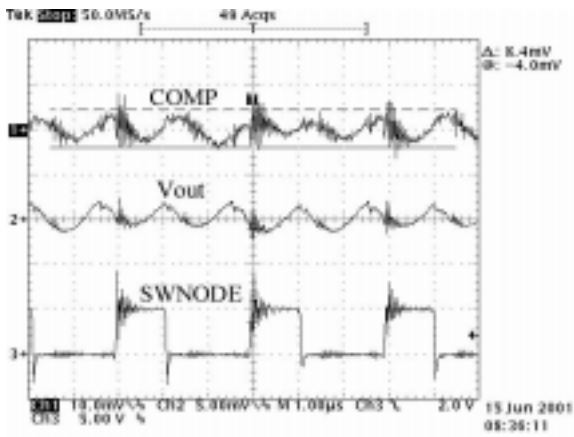


**Figure 23. The Value of  $C_{AMP}$  Is Too Low and the Loop Gain/Bandwidth Too High. COMP Moves Too Quickly, Which Is Evident from the Small Spike in Its Voltage When the Load Is Applied or Removed. The Output Voltage Transitions More Slowly Because of the COMP Spike.**



**Figure 24. The Value of  $C_{AMP}$  Is Optimal. COMP Slews Quickly Without Spiking or Ringing.  $V_{OUT}$  Does Not Overshoot and Monotonically Settles to Its Final Value.**

After the control loop is tuned to provide an acceptable transient response the steady-state voltage ripple on the COMP pin should be examined. When the converter is operating at full, steady-state load, the peak-to-peak voltage ripple on the COMP pin should be less than 20 mV<sub>PP</sub> as shown in Figure 25. Less than 10 mV<sub>PP</sub> is ideal. Excessive ripple on the COMP pin will contribute to output voltage jitter.



**Figure 25. At Full-Load (28 A) the Peak-to-Peak Voltage Ripple on the COMP Pin Should Be Less than 20 mV for a Well-Tuned/Stable Controller. Higher COMP Voltage Ripple Will Contribute to Output Voltage Jitter.**

### 9. Current Limit Setting

When the output of the current sense amplifier (CO1 or CO2 in the block diagram) exceeds the voltage on the  $I_{LIM}$  pin the part will enter hiccup mode. For inductive sensing, the  $I_{LIM}$  pin voltage should be set based on the inductor's maximum resistance ( $R_{LMAX}$ ). The design must consider the inductor's resistance increase due to current heating and ambient temperature rise. Also, depending on the current sense points, the circuit board may add additional resistance. In general, the temperature coefficient of copper is +0.39% per °C. If using a current sense resistor ( $R_{SENSE}$ ), the  $I_{LIM}$  pin voltage should be set based on the maximum value of the sense resistor. To set the level of the  $I_{LIM}$  pin:

$$V_{ILIM} = (I_{OUT,LIM} + \Delta I_{Lo}/2) \cdot R \cdot G_{ILIM} \quad (34)$$

where:

$I_{OUT,LIM}$  is the current limit threshold of the converter;

$\Delta I_{Lo}/2$  is half the inductor ripple current;

R is either ( $R_{LMAX} + R_{PCB}$ ) or  $R_{SENSE}$ ;

$G_{ILIM}$  is the current sense to  $I_{LIM}$  gain.

For the overcurrent protection to work properly, the current sense time constant (RC) should be slightly larger than the  $R_L$  time constant. If the RC time constant is too fast, during step load changes the sensed current waveform will appear larger than the actual inductor current and will probably trip the current limit at a lower level than expected.

### 10. PWM Comparator Input Voltage

The voltage at the positive input terminal of the PWM comparator (see Figure 9 or 11) is limited by the internal voltage supply of the controller (3.3 V), the size of the internal ramp, and the magnitude of the channel startup offset voltage. To prevent the PWM comparator from saturating, the differential input voltage from  $CS_{REF}$  to  $CS_n$  ( $n = 1$  or  $2$ ) must satisfy the following equation:

$$V_{CSREF,MAX} + V_{CON,MAX} + 310 \text{ mV} \cdot D \leq 2.45 \text{ V} \quad (35)$$

where:

$$V_{CSREF,MAX} = \text{Max VID Setting w/ AVP @ Full Load}$$

$$\begin{aligned} V_{CON,MAX} &= [V_{CSn} - V_{CSREF}] \cdot G_{CSA,MAX} \\ &= (I_{O,MAX}/2 + \Delta I_{Lo}/2) \cdot R_{MAX} \\ &\quad \cdot G_{CSA,MAX} \end{aligned}$$

$$R_{MAX} = R_{SENSE} \text{ or } (R_{L,MAX} + R_{PCB,MAX})$$

### 11. $V_{TTPGD}$ Delay Time Setting

The  $V_{TTPGD}$  signal is pulled LOW a predetermined delay time ( $T_{D,VTT}$ ) after the  $V_{TT}$  voltage crosses the  $V_{TT}$  Threshold. The  $V_{TTC}$  charge current and the capacitor value from the  $V_{TTC}$  pin to ground ( $C_{VTT}$ ) determine the  $T_{D,VTT}$  delay time. However, the choice of oscillator frequency and the value of  $R_{OSC}$  set the  $V_{TTC}$  charge current as shown in Figure 4. Therefore, delay time is simply set by the value of  $C_{VTT}$  according to the following equation:

$$T_{D,VTT} = (1 \text{ V} - 0.25\text{V}) \cdot C_{VTT}/V_{TTC\_Current} \quad (36)$$

### 12. Soft Start Time

The Soft Start time ( $T_{SS}$ ) can be calculated from:

$$T_{SS} = (V_{COMP} - R_{CMP1} \cdot I_{COMP}) \cdot C_{CMP2}/I_{COMP} \quad (37)$$

where:

$$\begin{aligned} V_{COMP} &= V_{OUT} @ 0 \text{ A} + \text{Channel\_Startup\_Offset} \\ &\quad + \text{Int\_Ramp} + G_{CSA} \cdot \text{Ext\_Ramp}/2 \end{aligned}$$

$I_{COMP}$  is the COMP source current from the data sheet.

**Design Example**

**Typical Design Requirements:**

- $V_{IN} = 5.0$  Vdc
- $V_{OUT} = 1.70$  Vdc (nominal)
- $V_{OUT,RIPPLE} = 10$  mV<sub>PP</sub> max
- VID Range: 1.050 Vdc – 1.825 Vdc
- $I_{O,MAX} = 28$  A at full-load
- $I_{OUT,LIM} = 33$  A min at 50°C (shutdown threshold)
- $di_{IN}/dt = 0.1$  A/μs max
- $f_{SW} = 335$  kHz
- $\eta = 81\%$  minimum
- $T_{A,MAX} = 60^{\circ}\text{C}$
- $T_{J,MAX} = 115^{\circ}\text{C}$
- $T_{D,VTT} = 2.5$  ms (VTT<sub>PGD</sub> delay time)
- $T_{SS} = 6.5$  ms (Soft Start time)
- $\Delta V_{OUT}$  at no-load (static) =  
+45 mV from VID setting = 1.745 Vdc
- $\Delta V_{OUT}$  at full-load (static) =  
–45 mV from VID setting = 1.655 Vdc
- $\Delta V_{OUT}$  at full-load (transient) =  
–90 mV from VID setting = 1.610 Vdc

**1. Output Capacitor Selection**

First, choose a low-cost, low-ESR output capacitor such as the Rubycon 6.3ZA1000M10X16: 6.3 V, 1000 μF, 1.65 A<sub>RMS</sub>, 24 mΩ, 10 × 16 mm. Calculate the minimum number of output capacitors:

$$N_{OUT,MIN} = \text{ESR per capacitor} \cdot \frac{\Delta I_{O,MAX}}{\Delta V_{O,MAX}} \quad (1)$$

$$= 24 \text{ m}\Omega \cdot 28 \text{ A} / (1.745 \text{ V} - 1.610 \text{ V})$$

$$= 4.987 \text{ or } 5 \text{ capacitors minimum (5000 } \mu\text{F)}$$

**2. Output Inductor Selection**

Calculate the minimum output inductance at  $I_{O,MAX}$  according to Equation 3 with ±20% inductor ripple current ( $\alpha = 0.20$ ):

$$L_{O,MIN} = \frac{(V_{IN} - V_{OUT}) \cdot V_{OUT}}{(\alpha \cdot I_{O,MAX} \cdot V_{IN} \cdot f_{SW})} \quad (3)$$

$$= \frac{(5 \text{ V} - 1.655 \text{ V}) \cdot 1.655 \text{ V}}{(0.2 \cdot 28 \text{ A} \cdot 5 \text{ V} \cdot 335 \text{ kHz})}$$

$$= 590 \text{ nH}$$

To save cost, we choose the inexpensive T50–52 core from Micrometals: 33 nH/N<sup>2</sup>, 3.19 cm./turn. At 14 A per phase the permeability of this core will be approximately 80% of the permeability at 0 A. Therefore, at 0 A we must achieve at least 590 nH/0.8 or 738 nH. Using four turns results in only 528 nH, so we must use five turns of #16AWG bifilar (2 mΩ/ft.) to produce 825 nH. This inductor is available as part number CTX22–15401 from Coiltronics.

Use Equation 4 to insure the output voltage ripple will satisfy the design goal with the minimum number of capacitors and the nominal output inductance:

$$V_{OUT,P-P} = (\text{ESR per cap} / N_{OUT,MIN}) \cdot \quad (4)$$

$$\{(V_{IN} - \#Phases \cdot V_{OUT}) \cdot D / (L_{O,MIN} \cdot f_{SW})\}$$

$$= (24 \text{ m}\Omega / 5) \cdot$$

$$\{(5.0 \text{ V} - 2 \cdot 1.7 \text{ V}) \cdot (1.7 \text{ V} / 5.0 \text{ V}) / (825 \text{ nH} \cdot 335 \text{ kHz})\}$$

$$= (4.8 \text{ m}\Omega) \cdot \{1.97 \text{ A}\}$$

$$= 9.45 \text{ mV}$$

The output voltage ripple will be decreased when output capacitors are added to satisfy transient loading requirements.

We will need the nominal and worst case inductor resistances for subsequent calculations:

$$R_L = 5 \text{ turns} \cdot 3.19 \text{ cm/turn} \cdot 0.03218 \text{ ft/cm} \cdot 2 \text{ m}\Omega/\text{ft}$$

$$= 1.03 \text{ m}\Omega$$

The inductor resistance will be maximized when the inductor is “hot” due to the load current and the ambient temperature is high. Assuming a 40°C temperature rise of the inductor at full-load and a 25°C ambient temperature rise we can calculate:

$$R_{L,MAX} = 1.03 \text{ m}\Omega \cdot [1 + 0.39\%/^{\circ}\text{C} \cdot (40^{\circ}\text{C} + 25^{\circ}\text{C})]$$

$$= 1.29 \text{ m}\Omega$$

**3. Input Capacitor Selection**

Use Equation 5 to determine the average input current to the converter:

$$I_{IN,AVG} = I_{O,MAX} \cdot D / \eta \quad (5)$$

$$= 28 \text{ A} \cdot (1.655 \text{ V} / 5.0 \text{ V}) / 0.81 = 11.44 \text{ A}$$

Next, use Equations 6 to 10:

$$\Delta I_{Lo} = (V_{IN} - V_{OUT}) \cdot D / (L_o \cdot f_{SW}) \quad (10)$$

$$= (5 \text{ V} - 1.655 \text{ V}) \cdot \frac{(1.655 \text{ V} / 5.0 \text{ V})}{(825 \text{ nH} \cdot 335 \text{ kHz})}$$

$$= 4.00 \text{ App}$$

$$I_{Lo,MAX} = I_{O,MAX} / 2 + \Delta I_{Lo} / 2 \quad (8)$$

$$= 28 \text{ A} / 2 + 4 \text{ App} / 2 = 16 \text{ A}$$

$$I_{Lo,MIN} = I_{O,MAX} / 2 - \Delta I_{Lo} / 2 \quad (9)$$

$$= 28 \text{ A} / 2 - 4 \text{ App} / 2 = 12 \text{ A}$$

$$I_{C,MAX} = I_{Lo,MAX} / \eta - I_{IN,AVG} \quad (6)$$

$$= 16 \text{ A} / 0.81 - 11.44 \text{ A} = 8.3 \text{ A}$$

$$I_{C,MIN} = I_{Lo,MIN} / \eta - I_{IN,AVG} \quad (7)$$

$$= 12 \text{ A} / 0.81 - 11.44 \text{ A} = 3.3 \text{ A}$$

For the two-phase converter, the input capacitor(s) RMS current is then (Note:  $D = 1.655 \text{ V} / 5 \text{ V} = 0.331$ ):

$$\begin{aligned}
 I_{CIN,RMS} &= [2D \cdot (I_{C,MIN}^2 + I_{C,MIN} \cdot \Delta I_{C,IN} \\
 &\quad + \Delta I_{C,IN}^2/3) + I_{IN,AVG}^2 \cdot (1 - 2D)]^{1/2} \quad (11) \\
 &= [0.662 \cdot (3.3^2 + 3.3 \cdot 5 + 5^2/3) + 11.44^2 \\
 &\quad \cdot (1 - 0.662)]^{1/2} \\
 &= 8.94 \text{ ARMS}
 \end{aligned}$$

At this point, the designer must decide between saving board space by using higher-rated/more costly capacitors or saving cost by using more lower-rated/less costly capacitors. To save board space, we choose the SP (Oscon) series capacitors by Sanyo: 680  $\mu$ F, 6.3 V, 4.84  $A_{RMS}$ , 13  $m\Omega$ , 10  $\times$  10.5mm. We need approximately 8.94 A/4.84 A = 1.84 or  $N_{IN} = 2$  capacitors on the input for a conservative design.

**4. Input Inductor Selection**

The input inductor must limit the input current slew rate to less than 0.1 A/ $\mu$ s during a load transient from 0 to 28 A. A conservative value will be calculated assuming the minimum number of output capacitors ( $N_{OUT} = 5$ ), two input capacitors ( $N_{IN} = 2$ ), worst case ESR values for both the input and output capacitors, and a maximum duty cycle ( $D = (1.825 \text{ V} + 45 \text{ mV}_{AVP})/5.0 \text{ V}_{IN} = 0.374$ ).

First, use Equation 15 to calculate the voltage across the output inductor due to the 28 A load current being shared equally between the two phases:

$$\begin{aligned}
 \Delta V_{L_O} &= V_{IN} - V_{OUT,NO-LOAD} \quad (15) \\
 &\quad + (I_{O,MAX}/2) \cdot ESR_{OUT}/N_{OUT} \\
 &= 5.0 \text{ V} - 1.87 \text{ V} + 14 \text{ A} \cdot 23 \text{ m}\Omega/5 \\
 &= 3.194 \text{ V}
 \end{aligned}$$

Second, use Equation 16 to determine the rate of current increase in the output inductor:

$$\begin{aligned}
 dl_{L_O}/dt &= \Delta V_{L_O}/L_O \quad (16) \\
 &= 3.194 \text{ V}/825 \text{ nH} = 3.872 \text{ V}/\mu\text{s}
 \end{aligned}$$

Finally, use Equations 17 and 18 to calculate the minimum input inductance value:

$$\begin{aligned}
 \Delta V_{C_i} &= ESR_{IN}/N_{IN} \cdot dl_{L_O}/dt \cdot D/f_{SW} \quad (17) \\
 &= 13 \text{ m}\Omega/2 \cdot 3.872 \mu\text{s} \cdot 0.374/335 \text{ kHz} \\
 &= 28.1 \text{ mV}
 \end{aligned}$$

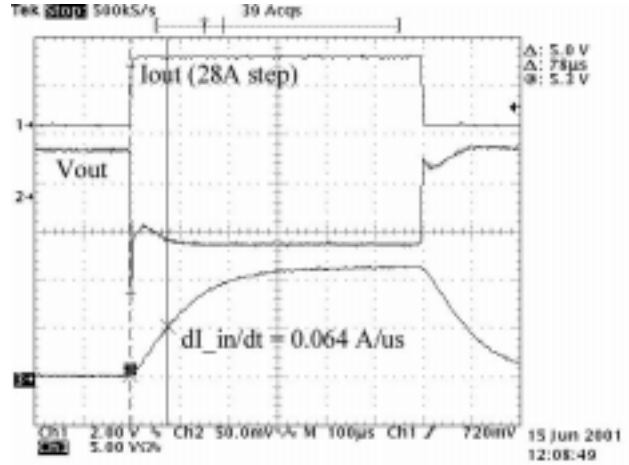
$$\begin{aligned}
 L_{iMIN} &= \Delta V_{C_i} / dl_{iN}/dt_{MAX} \quad (18) \\
 &= 28.1 \text{ mV}/0.1 \text{ A}/\mu\text{s} = 281 \text{ nH}
 \end{aligned}$$

We choose the small, cost effective T30–26 core from Micrometals (33.5 nH/ $N^2$ ) with #16 AWG. We need at least

2.89 or 3 turns to achieve the minimum inductance value. With three turns the input inductor will be:

$$L_i = 3^2 \cdot 33.5 \text{ nH}/N^2 = 301 \text{ nH}$$

This inductor is available as part number CTX15–14771 from Coiltronics.



**Figure 26. CS5308 Circuitry With Only 5 Rubycon Output Capacitors, 2 Oscon Input Capacitors and a 300 nH Input Inductor. The  $di_{iN}/dt$  of the Input Current (0.064 A/ $\mu$ s) Is Much Lower Than Expected (0.1 A/ $\mu$ s) Because of Input Voltage Drop and Lower Real ESRs Than Specified in the Capacitors’ Data Sheets.**

**5. MOSFET & Heatsink Selection**

The NTB75N03–06 from ON Semiconductor is chosen for both the control and synchronous MOSFET due to its low  $R_{DS(on)}$  and low gate–charge requirements. The following parameters are derived from the NTB75N03–06 data sheet:

- $R_{DS(on)} = 5.3 \text{ m}\Omega$
- $Q_{SWITCH} = 29 \text{ nC}$
- $Q_G = 52 \text{ nC}$
- $Q_{RR} = 23 \text{ nC}$
- $Q_{OSS} = 35 \text{ nC (approx.)}$
- $V_{f_{diode}} = 0.76 \text{ V @ 15 A}$
- $\theta_{JC} = 1.0^\circ\text{C} / \text{W}$

**CS5308 Parameters:**

- $i_G = 1 \text{ A}$
- $V_G = 10 \text{ V}$
- $t_{nonoverlap} = 65 \text{ ns}$

The RMS value of the current in the control MOSFET is calculated from Equation 20 and the previously derived values for  $D$ ,  $I_{LMAX}$ , and  $I_{LMIN}$  at the converter’s maximum output current:

$$\begin{aligned} I_{RMS,CNTL} &= \sqrt{D} \cdot [(I_{Lo,MAX}^2 + I_{Lo,MAX} \cdot I_{Lo,MIN} + I_{Lo,MIN}^2)/3]^{1/2} \\ &= 0.575 \cdot [(16^2 + 16 \cdot 12 + 12^2)/3]^{1/2} \\ &= 8.08 \text{ ARMS} \end{aligned} \quad (20)$$

Equation 19 is used to calculate the power dissipation of the control MOSFET:

$$\begin{aligned} P_{D,CONTROL} &= (I_{RMS,CNTL}^2 \cdot R_{DS(on)} + I_{Lo,MAX} \cdot Q_{switch}/I_g \cdot V_{IN} \cdot f_{SW} + (Q_{oss}/2 \cdot V_{IN} \cdot f_{SW}) + (V_{IN} \cdot Q_{RR} \cdot f_{SW})) \\ &= (8.08^2 \text{ ARMS} \cdot 5.3 \text{ m}\Omega + (16 \text{ A} \cdot 29 \text{ nC}/1 \text{ A} \cdot 5 \text{ V} \cdot 335 \text{ kHz}) + (35 \text{ nC}/2 \cdot 5 \text{ V} \cdot 335 \text{ kHz}) + (5 \text{ V} \cdot 23 \text{ nC} \cdot 335 \text{ kHz})) \\ &= 0.346 \text{ W} + 0.78 \text{ W} + 0.03 \text{ W} + 0.04 \text{ W} \\ &= 1.2 \text{ W} \end{aligned} \quad (19)$$

The RMS value of the current in the synchronous MOSFET is calculated from Equation 27 and the previously derived values for D,  $I_{Lo,MAX}$ , and  $I_{Lo,MIN}$  at the converter's maximum output current:

$$\begin{aligned} I_{RMS,SYNCH} &= \sqrt{1 - D} \cdot [(I_{Lo,MAX}^2 + I_{Lo,MAX} \cdot I_{Lo,MIN} + I_{Lo,MIN}^2)/3]^{1/2} \\ &= \sqrt{0.669} \cdot [(16^2 + 16 \cdot 12 + 12^2)/3]^{1/2} \\ &= 11.5 \text{ ARMS} \end{aligned} \quad (27)$$

Equation 26 is used to calculate the power dissipation of the synchronous MOSFET:

$$\begin{aligned} P_{D,SYNCH} &= (I_{RMS,SYNCH}^2 \cdot R_{DS(on)} + (V_{fdiode} \cdot I_{O,MAX}/2 \cdot t_{nonoverlap} \cdot f_{SW})) \\ &= (11.5^2 \text{ ARMS} \cdot 5.3 \text{ m}\Omega + (0.76 \text{ V} \cdot 28 \text{ A}/2 \cdot 65 \text{ ns} \cdot 335 \text{ kHz})) \\ &= 0.70 \text{ W} + 0.23 \text{ W} = 0.93 \text{ W} \end{aligned} \quad (26)$$

Equation 28 is used to calculate the heat sink thermal impedances necessary to maintain less than the specified maximum junction temperatures at 60°C ambient:

$$\theta_{CNTL} < (115 - 60^\circ\text{C})/1.2 \text{ W} - 1.0^\circ\text{C/W} = 46^\circ\text{C/W}$$

$$\theta_{SYNCH} < (115 - 60^\circ\text{C})/0.93 \text{ W} - 1.0^\circ\text{C/W} = 59^\circ\text{C/W}$$

If board area permits, a cost effective heatsink could be formed by using a TO-263 mounting pad of at least 1.0–1.5 in<sup>2</sup> per MOSFET on a single-sided, 1 oz. copper PCB (or 0.5 to 0.75 in<sup>2</sup> on each side of a two-sided board). If board space must be conserved, AAVID offers clip-on heatsinks for TO-220 thru-hole packages. Examples of these

heatsinks include #577002 (1" × 0.75" × 0.25", 39°C/W at 1 W) and #591302 (0.75" × 0.5" × 0.5", 34°C/W at 1 W)

## 6. Adaptive Voltage Positioning

First, to achieve the 335 kHz switching frequency, use Figure 3 to determine that a 39 kΩ resistor is needed for  $R_{OSC}$ . Then, use Figure 4 to find the  $V_{FB}$  bias current at the corresponding value of  $R_{OSC}$ . In this example, the 39 kΩ  $R_{OSC}$  resistor results in a  $V_{FB}$  bias current of approximately 7.0 μA. Knowing the  $V_{FB}$  bias current, one can calculate the required values for  $R_{VFBK}$  and  $R_{DRP}$  using Equations 29 through 31.

The no-load position is easily set using Equation 29:

$$\begin{aligned} R_{VFBK} &= \Delta V_{NO-LOAD}/I_{BIASV_{FB}} \\ &= +45 \text{ mV}/7.0 \mu\text{A} \\ &= 6.49 \text{ k}\Omega \end{aligned} \quad (29)$$

For inductive current sensing, the designer must calculate the inductor's resistance ( $R_L$ ) and approximate any resistance added by the circuit board ( $R_{PCB}$ ). We found the inductor's nominal resistance in Section 2 (1.03 mΩ). In this example, we approximate 0.75 mΩ for the circuit board resistance ( $R_{PCB}$ ). With this information, Equation 30 can be used to calculate the increase at the  $V_{DRP}$  pin at full load;

$$\begin{aligned} \Delta V_{DRP} &= I_{O,MAX} \cdot (R_L + R_{PCB}) \cdot G_{VDRP} \\ &= 28 \text{ A} \cdot (1.03 \text{ m}\Omega + 0.75 \text{ m}\Omega) \cdot 3.2 \text{ V/V} \\ &= 159 \text{ mV} \end{aligned} \quad (30)$$

$R_{DRP}$  can then be calculated from Equation 31:

$$\begin{aligned} R_{DRP} &= \frac{\Delta V_{DRP}}{(I_{BIASV_{FB}} + \Delta V_{OUT,FULL-LOAD}/R_{VFBK})} \\ &= 159 \text{ mV}/(7.0 \mu\text{A} + 45 \text{ mV}/6.49 \text{ k}\Omega) \\ &= 11.5 \text{ k}\Omega \end{aligned} \quad (31)$$

## 7. Current Sensing

Choose the current sense network ( $R_{CSn}$ ,  $C_{CSn}$ ,  $n = 1$  or  $2$ ) to satisfy

$$R_{CSn} \cdot C_{CSn} = L_o/(R_L + R_{PCB}) \quad (30)$$

The component values determined thus far are  $L_o = 825 \text{ nH}$ ,  $R_L = 1.03 \text{ m}\Omega$ , and  $R_{PCB} = 0.75 \text{ m}\Omega$ . We choose a convenient value for  $C_{CS1}$  (0.01 μF) and solve for  $R_{CS1}$ :

$$\begin{aligned} R_{CSn} &= 825 \text{ nH}/((1.03 \text{ m}\Omega + 0.75 \text{ m}\Omega)/0.01 \mu\text{F}) \\ &= 46 \text{ k}\Omega \text{ or } 50 \text{ k}\Omega \text{ when rounded up.} \end{aligned}$$

After the circuit is constructed, the values of  $R_{CSn}$  and/or  $C_{CSn}$  should be tuned to provide a "square-wave" at  $V_{DRP}$  with minimal overshoot and fast rise time due to a step change in load current as shown in Figures 19–21. Based on experience, the starting value for  $R_{CSn}$  is probably too low

and will need to be increased to provide a current sense signal similar to those in Figure 21.

Equation 30 will be most accurate for higher quality iron powder core materials such as the –2 or –8 from Micrometals. The permeability of these more expensive cores is relatively constant versus DC current, AC flux density and frequency. Less expensive core materials (such as the –52 from Micrometals) change their characteristics versus DC current, AC flux density, and frequency. The less expensive materials may yield acceptable converter performance if the current sense time constant is set approximately  $2\times$  longer than anticipated. For example, use approximately twice the resistance ( $R_{CSn}$ ) or twice the capacitance ( $C_{CSn}$ ) when using the less expensive core material. If we use –52 material for this design, the value of  $R_{CSn}$  should be increased to  $2 \times 50 \text{ k}\Omega$  or  $100 \text{ k}\Omega$ .

### 8. Error Amplifier Tuning

The error amplifier is tuned by adjusting  $C_{AMP}$  to provide an acceptable full-load transient response as shown in Figures 22–24. After a value for  $C_{AMP}$  is chosen, the peak-to-peak voltage ripple on the COMP pin is examined under full-load to insure less than  $20 \text{ mV}_{PP}$  as shown in Figure 25.

### 9. Current Limit Setting

The maximum inductor resistance, the maximum PCB resistance, and the maximum current-sense gain as shown in Equation 34 determine the current limit. The maximum current,  $I_{OUT,LIM}$ , was specified in the design requirements. The maximum inductor resistance occurs at full-load and the highest ambient temperature. This value was found in the “Output Inductor Section” ( $1.58 \text{ m}\Omega$ ). The PCB resistance increases due to the change in ambient temperature:

$$\begin{aligned} R_{PCB,MAX} &= 0.75 \text{ m}\Omega \cdot (1 + 0.39\%/^{\circ}\text{C} \cdot (60 - 25)^{\circ}\text{C}) \\ &= 0.85 \text{ m}\Omega \end{aligned}$$

$$\begin{aligned} V_{ILIM} &= (I_{OUT,LIM} + \Delta I_{Lo}/2) \cdot (R_{LMAX} + R_{PCB,MAX}) \\ &\quad \cdot G_{ILIM} \\ &= (33 \text{ A} + 4.0 \text{ A}/2) \cdot (1.29 \text{ m}\Omega + 0.85 \text{ m}\Omega) \\ &\quad \cdot 6.5 \text{ V/V} \\ &= 0.486 \text{ Vdc} \end{aligned}$$

Set the voltage at the  $I_{LIM}$  pin using a resistor divider from the  $3.3 \text{ V}$  reference output as shown in Figure 27. If the resistor from  $I_{LIM}$  to GND is chosen as  $1 \text{ k}$  ( $R_{LIM2}$ ), the resistor from  $I_{LIM}$  to  $3.3 \text{ V}$  can be calculated from:

$$\begin{aligned} R_{LIM1} &= (V_{REF} - V_{ILIM}) / (V_{ILIM} / R_{LIM2}) \\ &= (3.3 \text{ V} - 0.486 \text{ V}) / (0.486 \text{ V} / 1 \text{ k}\Omega) \\ &= 5790\Omega \text{ or } 5.76 \text{ k}\Omega \end{aligned}$$

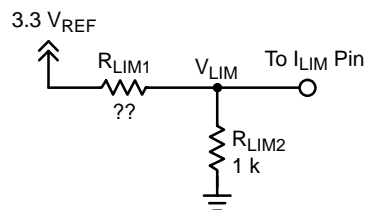


Figure 27. Setting the Current Limit

### 10. PWM Comparator Input Voltage

Use Equation 35 to check the voltage level to the positive pin of the internal PWM comparators to insure the design will not saturate the comparator at maximum DAC output voltage with 1% error, AVP at full-load, 100% duty cycle ( $D = 1$ ), and maximum internal ramp ( $310 \text{ mV}$  at 100% duty-cycle):

$$\begin{aligned} V_{CSREF,MAX} &= \text{Max VID Setting w/ AVP @ Full-Load} \\ &= 1.01 \cdot 1.825 \text{ V} - 45 \text{ mV} = 1.80 \text{ V} \end{aligned}$$

$$\begin{aligned} V_{CON,MAX} &= (I_{O,MAX}/2 + \Delta I_{Lo}/2) \cdot R_{MAX} \cdot G_{CSA,MAX} \\ &= (28 \text{ A}/2 + 4.0 \text{ A}/2) \cdot (1.29 \text{ m}\Omega + 0.82 \text{ m}\Omega) \\ &\quad \cdot 3.95 \text{ V/V} \\ &= 0.133 \text{ V} \end{aligned}$$

$$\begin{aligned} V_{CSREF,MAX} + V_{CON,MAX} + 310 \text{ mV} \cdot D &\quad (35) \\ &= 1.80 \text{ V} + 0.133 \text{ V} + 310 \text{ mV} \\ &= 2.243 \text{ V} \end{aligned}$$

This value is acceptable because it is below the specified maximum of  $2.45 \text{ V}$ .

### 11. $V_{TT,PGD}$ Delay Time Setting

To obtain the  $335 \text{ kHz}$  switching frequency the value of  $R_{OSC}$  was set to  $39 \text{ k}\Omega$  in Section 6. Figure 4 must be used to determine the value of the  $V_{TT,CT}$  Charge Current at this  $R_{OSC}$  value. In this example, the  $39 \text{ k}\Omega$   $R_{OSC}$  resistor results in a  $V_{TT,CT}$  Charge Current of approximately  $26 \mu\text{A}$ . Using Equation 34 and solving for  $C_{VTT}$ :

$$T_{D,VTT} = (1 \text{ V} - 0.25 \text{ V}) \cdot C_{VTT} / V_{TT,CT\_Current} \quad (34)$$

$$\begin{aligned} C_{VTT} &= T_{D,VTT} \cdot V_{TT,CT\_Current} / 0.75 \text{ V} \\ &= 2.5 \text{ ms} \cdot 26 \mu\text{A} / 0.75 \text{ V} \\ &= 0.086 \mu\text{F} \text{ or } 0.1 \mu\text{F} \end{aligned}$$

**12. Soft Start Time**

To set the Soft Start time we first approximate the COMP voltage at a duty-cycle of  $D = 1.745 \text{ V} / 5 \text{ V} = 0.349$ :

$$\begin{aligned} V_{\text{COMP}} &= V_{\text{OUT}} @ 0 \text{ A} + \text{Channel\_Startup\_Offset} \\ &\quad + \text{Int\_Ramp} \\ &= 1.745 \text{ V} + 0.40 \text{ V} + 250 \text{ mV} \cdot 0.349 \\ &= 2.232 \text{ V} \end{aligned}$$

We then choose a convenient value for  $R_{\text{CMP1}}$  ( $5.62 \text{ k}\Omega$ ) and solve Equation 37 for  $C_{\text{CMP2}}$ :

$$\begin{aligned} C_{\text{CMP2}} &= T_{\text{SS}} \cdot \frac{I_{\text{COMP}}}{(V_{\text{COMP}} - R_{\text{CMP1}} \cdot I_{\text{COMP}})} \\ &= 6.5 \text{ ms} \cdot \frac{30 \mu\text{A}}{(2.232 \text{ V} - 5.62 \text{ k}\Omega \cdot 30 \mu\text{A})} \\ &= 0.0945 \mu\text{F} \text{ or } 0.1 \mu\text{F} \end{aligned}$$

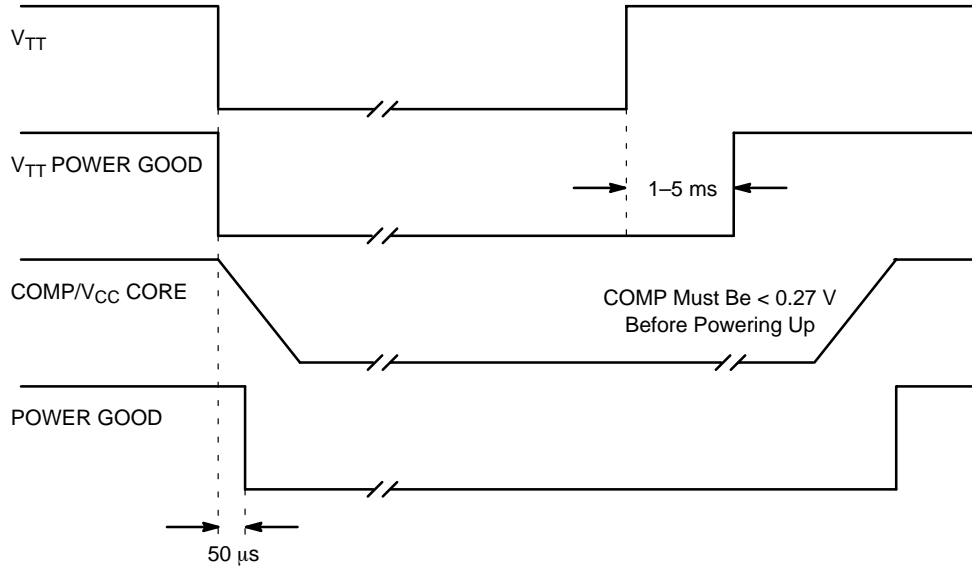
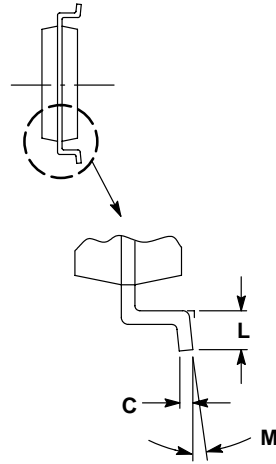
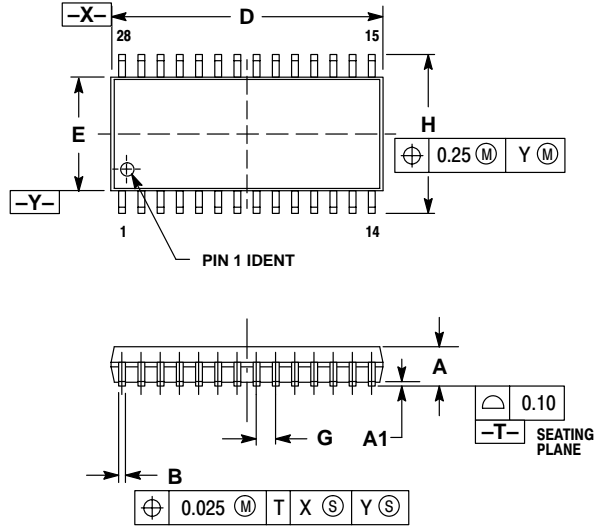


Figure 28. Timing Diagram, VTT Power Good

# CS5308

## PACKAGE DIMENSIONS

SO-28L  
DW SUFFIX  
CASE 751F-05  
ISSUE G




**NOTES:**

1. DIMENSIONING AND TOLERANCING PER ANSI Y14.5M, 1982.
2. CONTROLLING DIMENSION: MILLIMETER.
3. DIMENSIONS D AND E DO NOT INCLUDE MOLD PROTRUSION
4. MAXIMUM MOLD PROTRUSION 0.15 PER SIDE.
5. DIMENSION B DOES NOT INCLUDE DAMBAR PROTRUSION. ALLOWABLE DAMBAR PROTRUSION SHALL NOT BE 0.13 TOTAL IN EXCESS OF B DIMENSION AT MAXIMUM MATERIAL CONDITION.

DIM	MILLIMETERS	
	MIN	MAX
A	2.35	2.65
A1	0.13	0.29
B	0.35	0.49
C	0.23	0.32
D	17.80	18.05
E	7.40	7.60
G	1.27 BSC	
H	10.05	10.55
L	0.41	0.90
M	0°	8°

**Notes**

V<sup>2</sup> is a trademark of Switch Power, Inc.  
Pentium is a registered trademark of Intel, Corp.

**ON Semiconductor** and  are registered trademarks of Semiconductor Components Industries, LLC (SCILLC). SCILLC reserves the right to make changes without further notice to any products herein. SCILLC makes no warranty, representation or guarantee regarding the suitability of its products for any particular purpose, nor does SCILLC assume any liability arising out of the application or use of any product or circuit, and specifically disclaims any and all liability, including without limitation special, consequential or incidental damages. "Typical" parameters which may be provided in SCILLC data sheets and/or specifications can and do vary in different applications and actual performance may vary over time. All operating parameters, including "Typicals" must be validated for each customer application by customer's technical experts. SCILLC does not convey any license under its patent rights nor the rights of others. SCILLC products are not designed, intended, or authorized for use as components in systems intended for surgical implant into the body, or other applications intended to support or sustain life, or for any other application in which the failure of the SCILLC product could create a situation where personal injury or death may occur. Should Buyer purchase or use SCILLC products for any such unintended or unauthorized application, Buyer shall indemnify and hold SCILLC and its officers, employees, subsidiaries, affiliates, and distributors harmless against all claims, costs, damages, and expenses, and reasonable attorney fees arising out of, directly or indirectly, any claim of personal injury or death associated with such unintended or unauthorized use, even if such claim alleges that SCILLC was negligent regarding the design or manufacture of the part. SCILLC is an Equal Opportunity/Affirmative Action Employer.

## PUBLICATION ORDERING INFORMATION

### Literature Fulfillment:

Literature Distribution Center for ON Semiconductor  
P.O. Box 5163, Denver, Colorado 80217 USA  
**Phone:** 303-675-2175 or 800-344-3860 Toll Free USA/Canada  
**Fax:** 303-675-2176 or 800-344-3867 Toll Free USA/Canada  
**Email:** ONlit@hibbertco.com

**N. American Technical Support:** 800-282-9855 Toll Free USA/Canada

**JAPAN:** ON Semiconductor, Japan Customer Focus Center  
4-32-1 Nishi-Gotanda, Shinagawa-ku, Tokyo, Japan 141-0031  
**Phone:** 81-3-5740-2700  
**Email:** r14525@onsemi.com

**ON Semiconductor Website:** <http://onsemi.com>

For additional information, please contact your local  
Sales Representative.

## Looking for pricing, stock, or lifecycle information?

Click below to explore more details on WIN SOURCE:

 [View CS5308GDWR28](#) on WIN SOURCE

 [ON Semiconductor](#) Information

## Optimize Your Supply Chain with WIN SOURCE Solutions

-  Global Sourcing Solution
-  Obsolete Management
-  Cost Control Management
-  Shortage Management
-  Alternative Solution
-  Excess Inventory Management