



**THE DATASHEET OF
TPS54623RHLT**



TPS54623 4.5-V to 17-V Input, 6-A Synchronous Step-Down SWIFT™ Converter With Light Load Efficiency and Hiccup Overcurrent Protection

1 Features

- Integrated 26 mΩ, 19 mΩ MOSFETs
- Split Power Rail: 1.6 V to 17 V on PVIN
- 200 kHz to 1.6 MHz Switching Frequency
- Light Load Efficient With Pulse Skip
- Synchronizes to External Clock
- 0.6 V ±1% Voltage Reference Overtemperature
- Low 2-μA Shutdown Quiescent Current
- Monotonic Start-Up into Pre-biased Outputs
- –40°C to 150°C Operating Junction Temperature Range
- Adjustable Slow Start and Power Sequencing
- Power Good Output Monitor for Undervoltage and Overvoltage
- Adjustable Input Undervoltage Lockout
- Create a Custom Design Using the TPS54623 With the [WEBENCH® Power Designer](#)

2 Applications

- High Density Distributed Power Systems
- High Performance Point of Load Regulation
- Broadband, Networking, and Optical Communications Infrastructure

Simplified Schematic

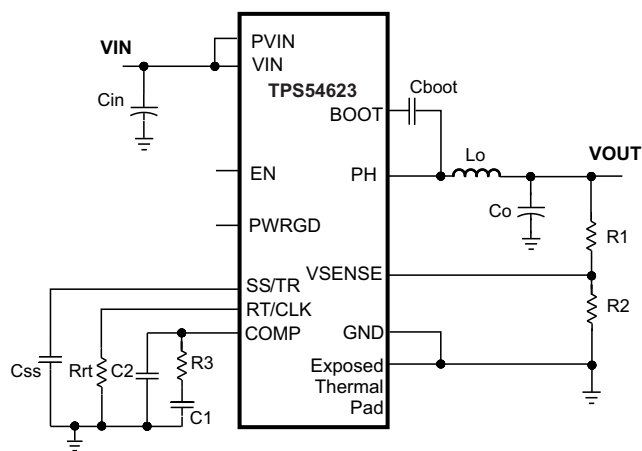

Copyright © 2016, Texas Instruments Incorporated

3 Description

The TPS54623 in thermally enhanced VQFN package is a full featured 17-V, 6-A synchronous step-down converter which is optimized for small designs through high efficiency and integrating the high-side and low-side MOSFETs. Further space savings are achieved through current mode control, which reduces component count, and by selecting a high switching frequency, reducing the inductor's footprint.

The output voltage start-up ramp is controlled by the SS/TR pin, which allows operation as either a stand alone power supply or in tracking situations. Power sequencing is also possible by correctly configuring the enable and the open drain power good pins.

Cycle-by-cycle current limiting on the high-side FET protects the device in overload situations and is enhanced by a low-side sourcing current limit which prevents current runaway. There is also a low-side sinking current limit that turns off the low-side MOSFET to prevent excessive reverse current. Hiccup protection will be triggered if the overcurrent condition has persisted for longer than the preset time. Thermal hiccup protection disables the device when the die temperature exceeds the thermal shutdown temperature and enables the part again after the built-in thermal shutdown hiccup time. The TPS54623 operates at continuous current mode (CCM) at higher load conditions while skipping pulses to boost the efficiency at light loads.

Device Information⁽¹⁾

PART NUMBER	PACKAGE	BODY SIZE (NOM)
TPS54623	VQFN (14)	3.50 mm x 3.50 mm

(1) For all available packages, see the orderable addendum at the end of the data sheet.

Efficiency vs Load Current

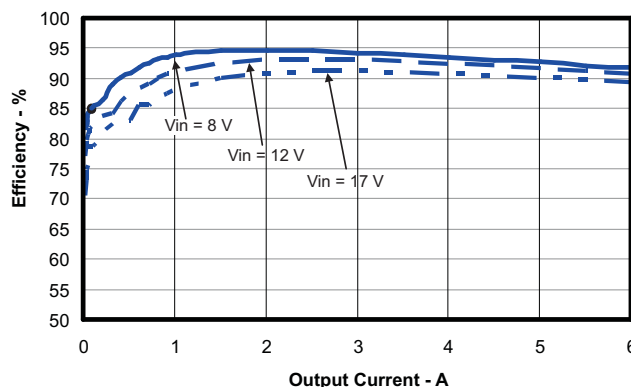

Table of Contents

1 Features	1	8 Application and Implementation	24
2 Applications	1	8.1 Application Information.....	24
3 Description	1	8.2 Typical Application	24
4 Revision History	2	9 Power Supply Recommendations	32
5 Pin Configuration and Functions	3	10 Layout	32
6 Specifications	4	10.1 Layout Guidelines	32
6.1 Absolute Maximum Ratings	4	10.2 Layout Examples.....	33
6.2 ESD Ratings.....	4	11 Device and Documentation Support	35
6.3 Recommended Operating Conditions	4	11.1 Device Support.....	35
6.4 Thermal Information	5	11.2 Documentation Support	35
6.5 Electrical Characteristics.....	5	11.3 Receiving Notification of Documentation Updates	35
6.6 Typical Characteristics	7	11.4 Community Resources.....	35
7 Detailed Description	10	11.5 Trademarks	35
7.1 Overview	10	11.6 Electrostatic Discharge Caution.....	36
7.2 Functional Block Diagram	11	11.7 Glossary	36
7.3 Feature Description.....	11	12 Mechanical, Packaging, and Orderable	36
7.4 Device Functional Modes.....	21	Information	36

4 Revision History

Changes from Revision B (January 2017) to Revision C	Page
• Added top nav icon for TI Design	1
• Added links for WEBENCH on page 1 and in <i>Application and Implementation</i> and <i>Device and Documentation Support</i> sections	1
• minor editorial edits	1
• Changed $R_{\theta JA}$ value from "47.2" to "40.1"	5
• Changed $R_{\theta J C top}$ value from "64.8" to "34.4"	5
• $R_{\theta JB}$ value from "14.4" to "11.4"	5
• Changed ψ_{JB} value from "14.7" to "11.4"	5
• Changed $R_{\theta J C bot}$ value from "3.2" to "1.8"	5
• Added new paragraph to end of <i>Sequencing (SS/TR)</i>	16

Changes from Revision A (March 2016) to Revision B	Page
• Changed Error amplifier dc gain test conditions, VSENSE from 0.8 V to 0.6 V	5
• Changed the voltage reference (Vref) from 0.8 V to 0.6 V in <i>Slow Start (SS/TR)</i> description.	14
• Changed "...internal voltage reference of 0.8 V. Above 0.8 V.." to "...internal voltage reference of 0.6 V. Above 0.6 V..." in <i>Minimum Output Voltage</i> description.	28

Changes from Original (September 2011) to Revision A	Page
• Added <i>ESD Ratings</i> table, <i>Feature Description</i> section, <i>Device Functional Modes</i> , <i>Application and Implementation</i> section, <i>Power Supply Recommendations</i> section, <i>Layout</i> section, <i>Device and Documentation Support</i> section, and <i>Mechanical, Packaging, and Orderable Information</i> section	1
• Deleted Ordering Information table	3

5 Pin Configuration and Functions

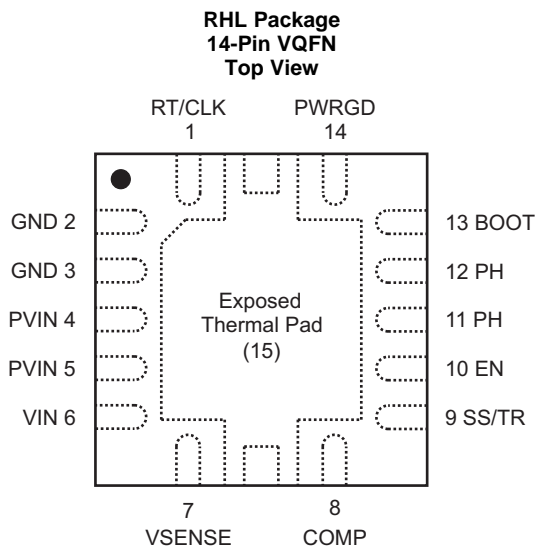

Pin Functions

PIN		I/O	DESCRIPTION
NAME	NO		
BOOT	13	O	A bootstrap cap is required between BOOT and PH. The voltage on this cap carries the gate drive voltage for the high-side MOSFET.
COMP	8	I/O	Error amplifier output, and input to the output switch current comparator. Connect frequency compensation to this pin.
EN	10	I	Enable pin. Float to enable. Adjust the input undervoltage lockout with two resistors.
GND	2	—	Return for control circuitry and low-side power MOSFET.
GND	3	—	Return for control circuitry and low-side power MOSFET.
PH	11	O	The switch node.
PH	12	O	The switch node.
PVIN	4	I	Power input. Supplies the power switches of the power converter.
PVIN	5	I	Power input. Supplies the power switches of the power converter.
PWRGD	14	O	Power Good fault pin. Asserts low if output voltage is low due to thermal shutdown, dropout, over-voltage, EN shutdown or during slow start.
RT/CLK	1	I	Automatically selects between RT mode and CLK mode. An external timing resistor adjusts the switching frequency of the device; In CLK mode, the device synchronizes to an external clock.
SS/TR	9	I	Slow-start and tracking. An external capacitor connected to this pin sets the internal voltage reference rise time. The voltage on this pin overrides the internal reference. It can be used for tracking and sequencing.
VIN	6	I	Supplies the control circuitry of the power converter.
VSENSE	7	I	Inverting input of the gm error amplifier.
Exposed Thermal Pad	15	—	Thermal pad of the package and signal ground and it must be soldered down for proper operation.

6 Specifications

6.1 Absolute Maximum Ratings

over operating free-air temperature range (unless otherwise noted)⁽¹⁾

		MIN	MAX	UNIT
Input voltage	VIN	-0.3	20	V
	PVIN	-0.3	20	
	EN	-0.3	6	
	BOOT	-0.3	27	
	VSENSE	-0.3	3	
	COMP	-0.3	3	
	PWRGD	-0.3	6	
	SS/TR	-0.3	3	
	RT/CLK	-0.3	6	
Output voltage	BOOT-PH	0	7.5	V
	PH	-1	20	
	PH (10-ns transient)	-3	20	
Vdiff (GND to exposed thermal pad)		-0.2	0.2	V
Source current	RT/CLK	±100		µA
	PH	Current limit		A
Sink current	PH	Current limit		A
	PVIN	Current limit		A
	COMP	±200		µA
	PWRGD	-0.1	5	mA
Operating junction temperature, T _J		-40	150	°C
Storage temperature, T _{stg}		-65	150	°C

(1) Stresses beyond those listed under *Absolute Maximum Ratings* may cause permanent damage to the device. These are stress ratings only, which do not imply functional operation of the device at these or any other conditions beyond those indicated under *Recommended Operating Conditions*. Exposure to absolute-maximum-rated conditions for extended periods may affect device reliability.

6.2 ESD Ratings

		VALUE	UNIT
V _(ESD) Electrostatic discharge	Human-body model (HBM), per ANSI/ESDA/JEDEC JS-001 ⁽¹⁾	±2000	V
	Charged-device model (CDM), per JEDEC specification JESD22-C101 ⁽²⁾	±500	

(1) JEDEC document JEP155 states that 500-V HBM allows safe manufacturing with a standard ESD control process.

(2) JEDEC document JEP157 states that 250-V CDM allows safe manufacturing with a standard ESD control process.

6.3 Recommended Operating Conditions

over operating free-air temperature range (unless otherwise noted)

		MIN	NOM	MAX	UNIT
V _{VIN}	Input voltage	4.5		17	V
V _{PVIN}	Input voltage	1.7		17	V
I _{OUT}	Output current	0		6	A
T _J	Operating junction temperature	-40		150	°C

6.4 Thermal Information

THERMAL METRIC ⁽¹⁾⁽²⁾		TPS54623	UNIT	
		RHL (VQFN)		
		14 PINS		
R _{θJA}	Junction-to-ambient	Thermal resistance	40.1	°C/W
		Test board ⁽³⁾	32	
R _{θJC(top)}	Junction-to-case (top) thermal resistance		34.4	°C/W
R _{θJB}	Junction-to-board thermal resistance		11.4	°C/W
ψ _{JT}	Junction-to-top characterization parameter		0.5	°C/W
ψ _{JB}	Junction-to-board characterization parameter		11.4	°C/W
R _{θJC(bot)}	Junction-to-case (bottom) thermal resistance		1.8	°C/W

- (1) For more information about traditional and new thermal metrics, see the [Semiconductor and IC Package Thermal Metrics](#) application report.
- (2) Power rating at a specific ambient temperature T_A should be determined with a junction temperature of 150°C. This is the point where distortion starts to substantially increase. Thermal management of the PCB should strive to keep the junction temperature at or below 150°C for best performance and long-term reliability. See power dissipation estimate in application section of this data sheet for more information.
- (3) Test board conditions:
 - (a) 2.5 inches x 2.5 inches, 4 layers, thickness: 0.062 inch
 - (b) 2 oz. copper traces located on the top of the PCB
 - (c) 2 oz. copper ground planes on the 2 internal layers and bottom layer
 - (d) 4 0.010 inch thermal vias located under the device package

6.5 Electrical Characteristics

T_J = -40°C to 150°C, V_{IN} = 4.5 V to 17 V, P_{VIN} = 1.6 V to 17 V (unless otherwise noted)

PARAMETER	TEST CONDITIONS	MIN	TYP	MAX	UNIT
SUPPLY VOLTAGE (VIN AND PVIN PINS)					
PVIN operating input voltage		1.6		17	V
VIN operating input voltage		4.5		17	V
VIN internal UVLO threshold	VIN rising		4.0	4.5	V
VIN internal UVLO hysteresis			150		mV
VIN shutdown supply Current	EN = 0 V		2	5	μA
VIN operating – non switching supply current	VSENSE = 810 mV		250	500	μA
ENABLE AND UVLO (EN PIN)					
Enable threshold	Rising		1.21	1.26	V
Enable threshold	Falling	1.10	1.17		V
Input current	EN = 1.1 V		1.15		μA
Hysteresis current	EN = 1.3 V		3.3		μA
VOLTAGE REFERENCE					
Voltage reference	0 A ≤ I _{OUT} ≤ 6 A	0.594	0.6	0.606	V
MOSFET					
High-side switch resistance	BOOT-PH = 3 V		32	60	mΩ
High-side switch resistance ⁽¹⁾	BOOT-PH = 6 V		26	40	mΩ
Low-side switch resistance ⁽¹⁾	VIN = 12 V		19	30	mΩ
ERROR AMPLIFIER					
Error amplifier Transconductance (gm)	-2 μA < I _{COMP} < 2 μA, V _(COMP) = 1 V		1300		μMhos
Error amplifier dc gain	VSENSE = 0.6 V	1000	3100		V/V
Error amplifier source/sink	V _(COMP) = 1 V, 100 mV input overdrive		±110		μA
Start switching peak current threshold			1		A
COMP to I _{switch} gm			16		A/V

- (1) Measured at pins

Electrical Characteristics (continued)
 $T_J = -40^{\circ}\text{C}$ to 150°C , $V_{IN} = 4.5\text{ V}$ to 17 V , $PV_{IN} = 1.6\text{ V}$ to 17 V (unless otherwise noted)

PARAMETER	TEST CONDITIONS	MIN	TYP	MAX	UNIT
CURRENT LIMIT					
High-side switch current limit threshold		8	11	14	A
Low-side switch sourcing current limit		6.5	10	15	A
Low-side switch sinking current limit			200	600	mA
Hiccup wait time			512		Cycles
Hiccup time before re-start			16384		Cycles
THERMAL SHUTDOWN					
Thermal shutdown		160	175		$^{\circ}\text{C}$
Thermal shutdown hysteresis			10		$^{\circ}\text{C}$
Thermal shutdown hiccup time			16384		Cycles
TIMING RESISTOR AND EXTERNAL CLOCK (RT/CLK PIN)					
Minimum switching frequency	$R_{RT} = 240\text{ k}\Omega$ (1%)	160	200	240	kHz
Switching frequency	$R_{RT} = 100\text{ k}\Omega$ (1%)	400	480	560	kHz
Maximum switching frequency	$R_{RT} = 29\text{ k}\Omega$ (1%)	1440	1600	1760	kHz
Minimum pulse width			20		ns
RT/CLK high threshold				2	V
RT/CLK low threshold		0.8			V
RT/CLK falling edge to PH rising edge delay	Measure at 500 kHz with RT resistor in series		66		ns
Switching frequency range (RT mode set point and PLL mode)		200		1600	kHz
PH (PH PIN)					
Minimum on-time	Measured at 90% to 90% of V_{IN} , 25°C , $I_{PH} = 2\text{ A}$		94	145	ns
Minimum off-time	$BOOT-PH \geq 3\text{ V}$		0		ns
BOOT (BOOT PIN)					
BOOT-PH UVLO			2.1	3	V
SLOW START AND TRACKING (SS/TR PIN)					
SS charge current			2.3		μA
SS/TR to VSENSE matching	$V_{(SS/TR)} = 0.4\text{ V}$		20	60	mV
POWER GOOD (PWRGD PIN)					
VSENSE threshold	VSENSE falling (Fault)		92%		V_{ref}
VSENSE rising (good)			94%		V_{ref}
VSENSE rising (Fault)			106%		V_{ref}
VSENSE falling (Good)			104%		V_{ref}
Output high leakage	$V_{SENSE} = V_{ref}$, $V_{(PWRGD)} = 5.5\text{ V}$		30	100	nA
Output low	$I_{(PWRGD)} = 2\text{ mA}$			0.3	V
Minimum V_{IN} for valid output	$V_{(PWRGD)} < 0.5\text{ V}$ at $100\text{ }\mu\text{A}$		0.6	1	V
Minimum SS/TR voltage for PWRGD				1.4	V

6.6 Typical Characteristics

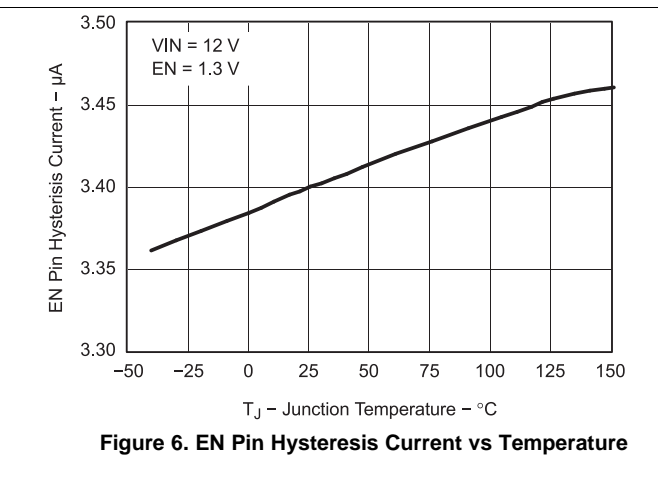
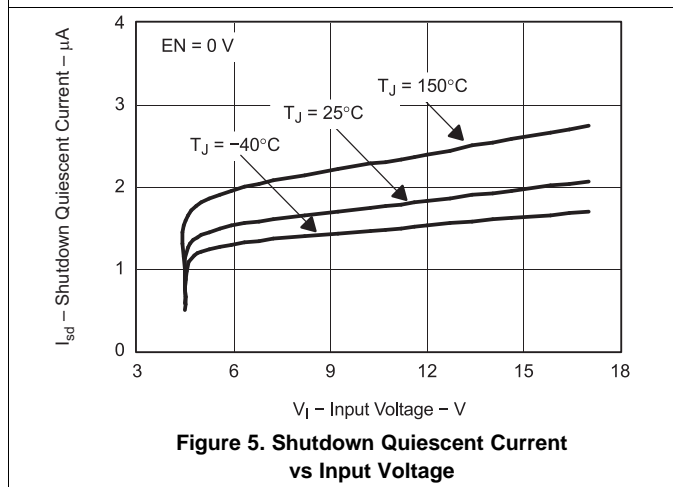
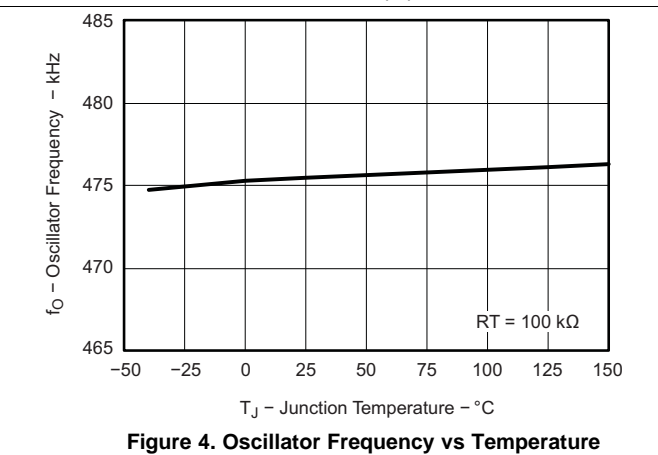
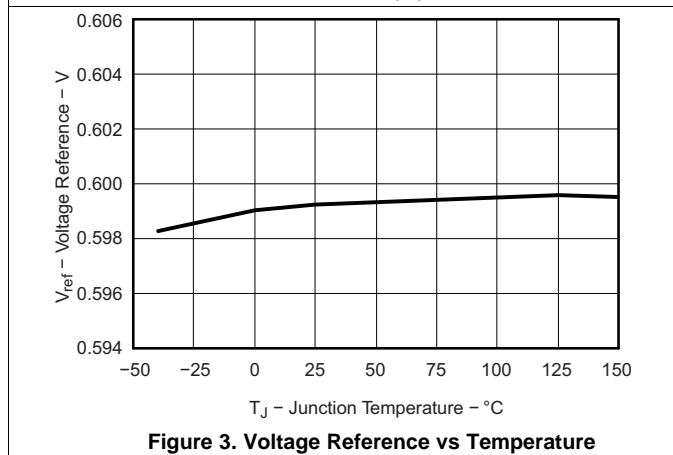
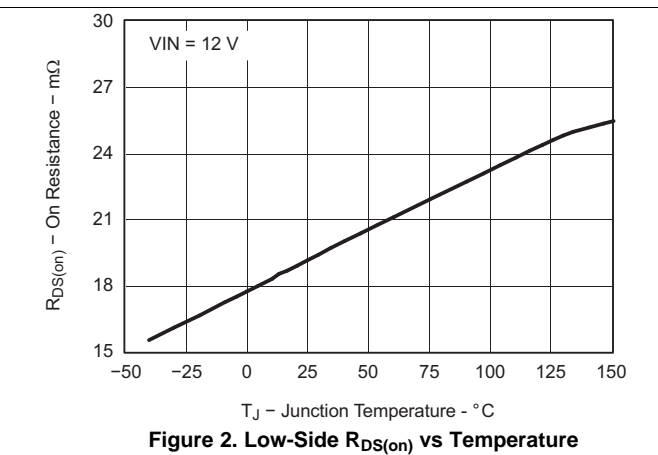
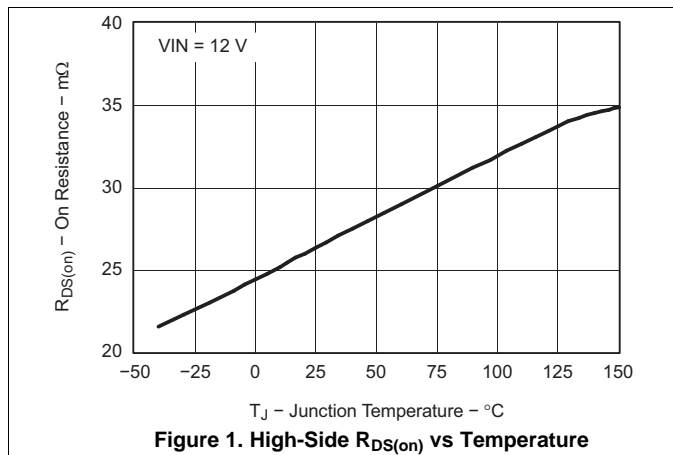

Typical Characteristics (continued)

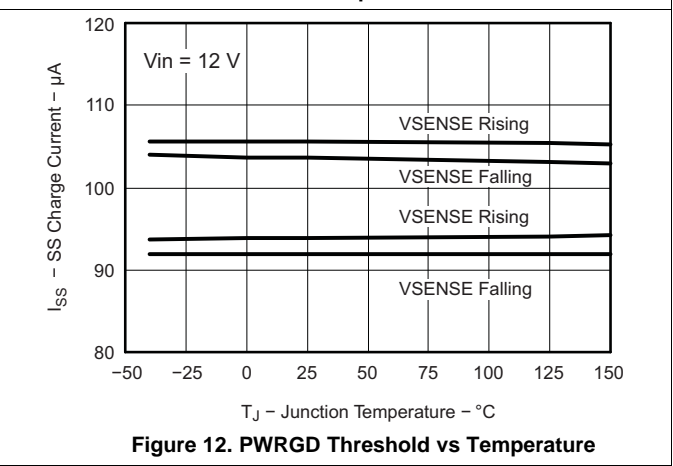
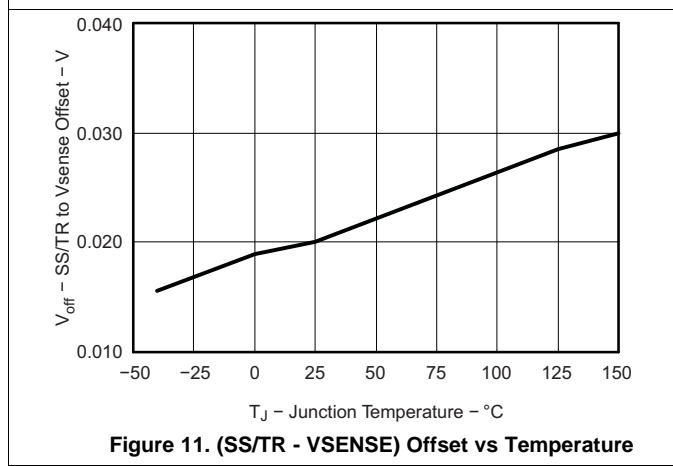
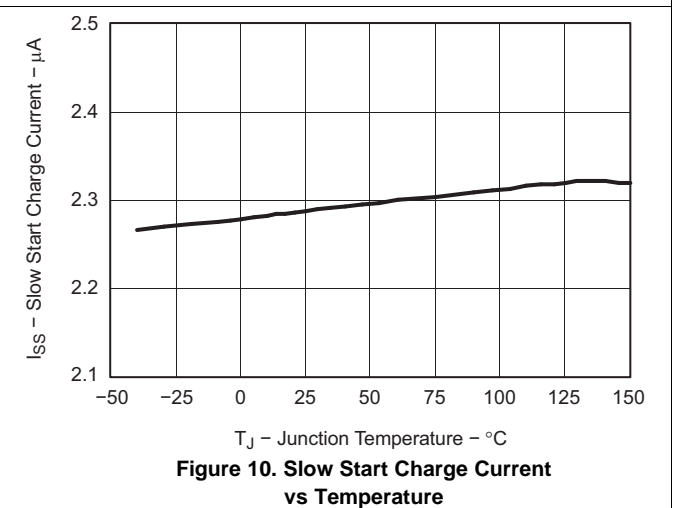
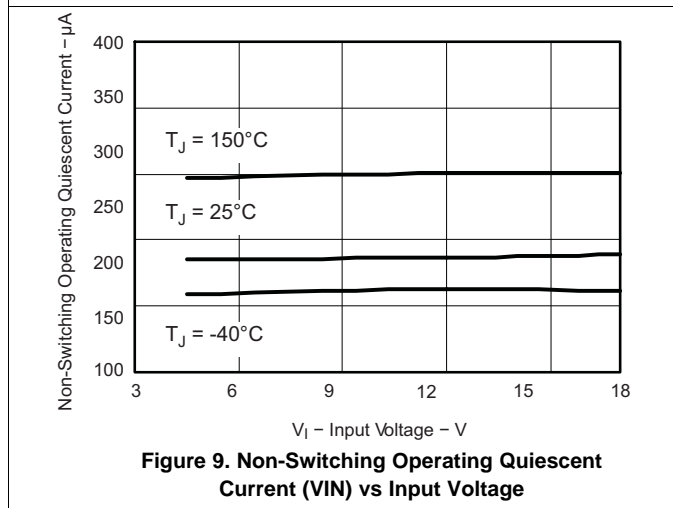
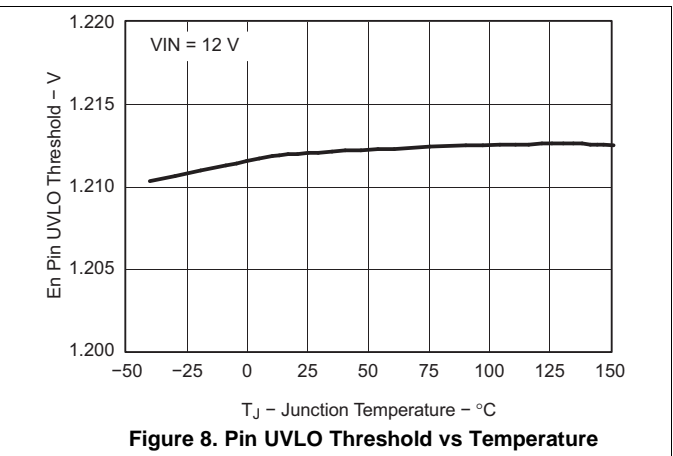
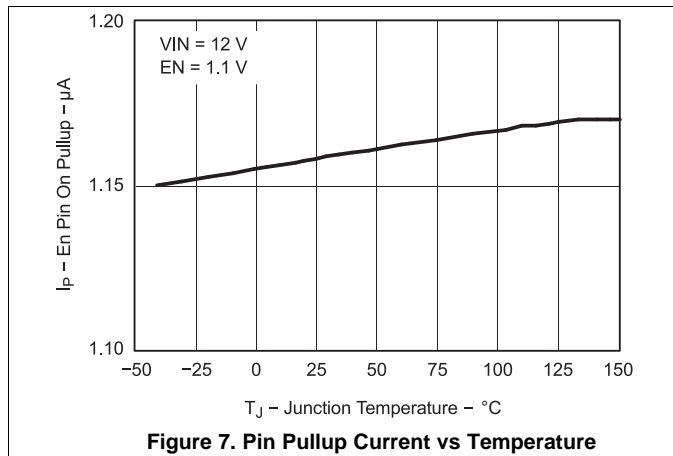

Typical Characteristics (continued)

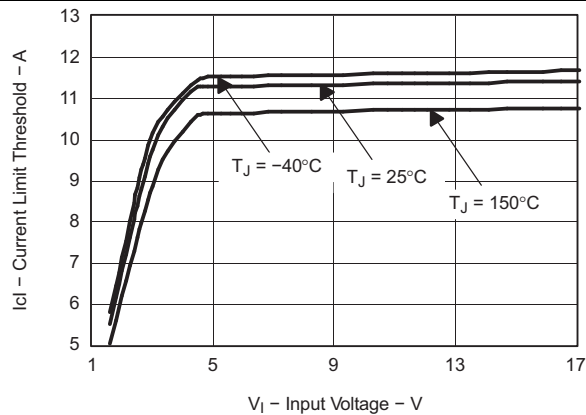

Figure 13. High-Side Current limit Threshold vs Input Voltage

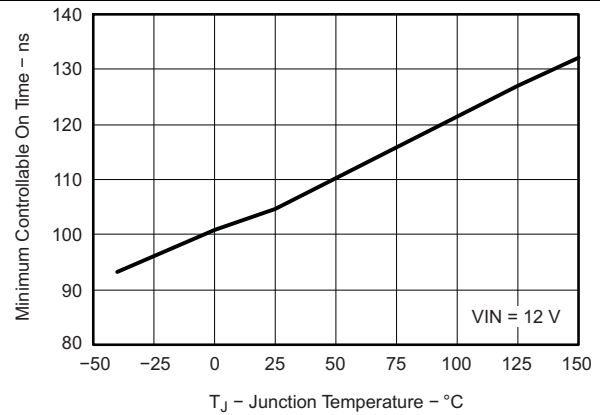

Figure 14. Minimum Controllable On Time vs Temperature

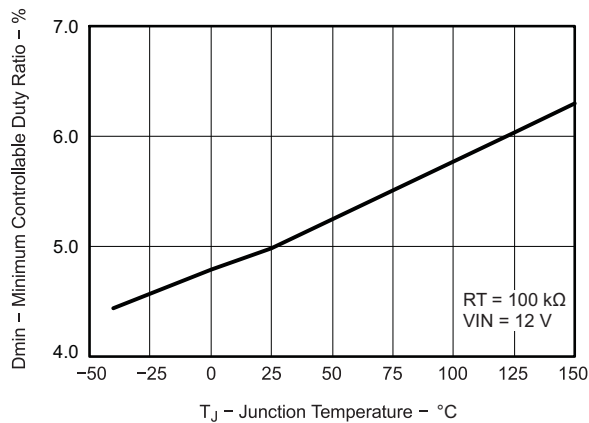

Figure 15. Minimum Controllable Duty Ratio vs Junction Temperature

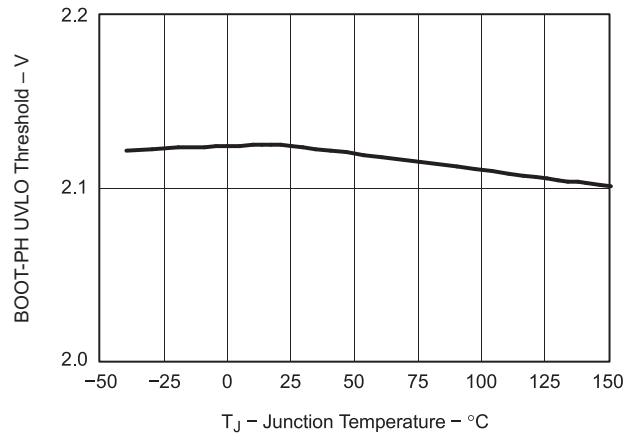

Figure 16. BOOT-PH UVLO Threshold vs Temperature

7 Detailed Description

7.1 Overview

The device is a 17-V, 6-A, synchronous step-down (buck) converter with two integrated n-channel MOSFETs. To improve performance during line and load transients the device implements a constant frequency, peak current mode control which also simplifies external frequency compensation. The wide switching frequency of 200 kHz to 1600 kHz allows for efficiency and size optimization when selecting the output filter components. The switching frequency is adjusted using a resistor to ground on the RT/CLK pin. The device also has an internal phase lock loop (PLL) controlled by the RT/CLK pin that can be used to synchronize the switching cycle to the falling edge of an external system clock.

The device has been designed for safe monotonic start-up into pre-biased loads. The default start up is when VIN is typically 4 V. The EN pin has an internal pullup current source that can be used to adjust the input voltage under voltage lockout (UVLO) with two external resistors. In addition, the EN pin can be floating for the device to operate with the internal pullup current. The total operating current for the device is approximately 600 μ A when not switching and under no load. When the device is disabled, the supply current is typically less than 2 μ A.

The integrated MOSFETs allow for high efficiency power supply designs with continuous output currents up to 6 A. The MOSFETs have been sized to optimize efficiency for lower duty cycle applications.

The device reduces the external component count by integrating the boot recharge circuit. The bias voltage for the integrated high-side MOSFET is supplied by a capacitor between the BOOT and PH pins. The boot capacitor voltage is monitored by a BOOT to PH UVLO (BOOT-PH UVLO) circuit allowing PH pin to be pulled low to recharge the boot capacitor. The device can operate at 100% duty cycle as long as the boot capacitor voltage is higher than the preset BOOT-PH UVLO threshold which is typically 2.1 V. The output voltage can be stepped down to as low as the 0.6 V voltage reference (Vref).

The device has a power good comparator (PWRGD) with hysteresis which monitors the output voltage through the VSENSE pin. The PWRGD pin is an open drain MOSFET which is pulled low when the VSENSE pin voltage is less than 92% or greater than 106% of the reference voltage Vref and asserts high when the VSENSE pin voltage is 94% to 104% of the Vref.

The SS/TR (slow start/tracking) pin is used to minimize inrush currents or provide power supply sequencing during power up. A small value capacitor or resistor divider should be coupled to the pin for slow start or critical power supply sequencing requirements.

The device is protected from output overvoltage, overload and thermal fault conditions. The device minimizes excessive output overvoltage transients by taking advantage of the overvoltage circuit power good comparator. When the overvoltage comparator is activated, the high-side MOSFET is turned off and prevented from turning on until the VSENSE pin voltage is lower than 104% of the Vref. The device implements both high-side MOSFET overload protection and bidirectional low-side MOSFET overload protections which help control the inductor current and avoid current runaway. The device also shuts down if the junction temperature is higher than thermal shutdown trip point. The device is restarted under control of the slow start circuit automatically after the built-in thermal shutdown hiccup time.

The TPS54623 monitors the peak switch current of the high-side MOSFET. Once the peak switch current is lower than typically 1 A, the device stops switching to boost the efficiency until the peak switch current is higher than typically 1 A again.

7.2 Functional Block Diagram

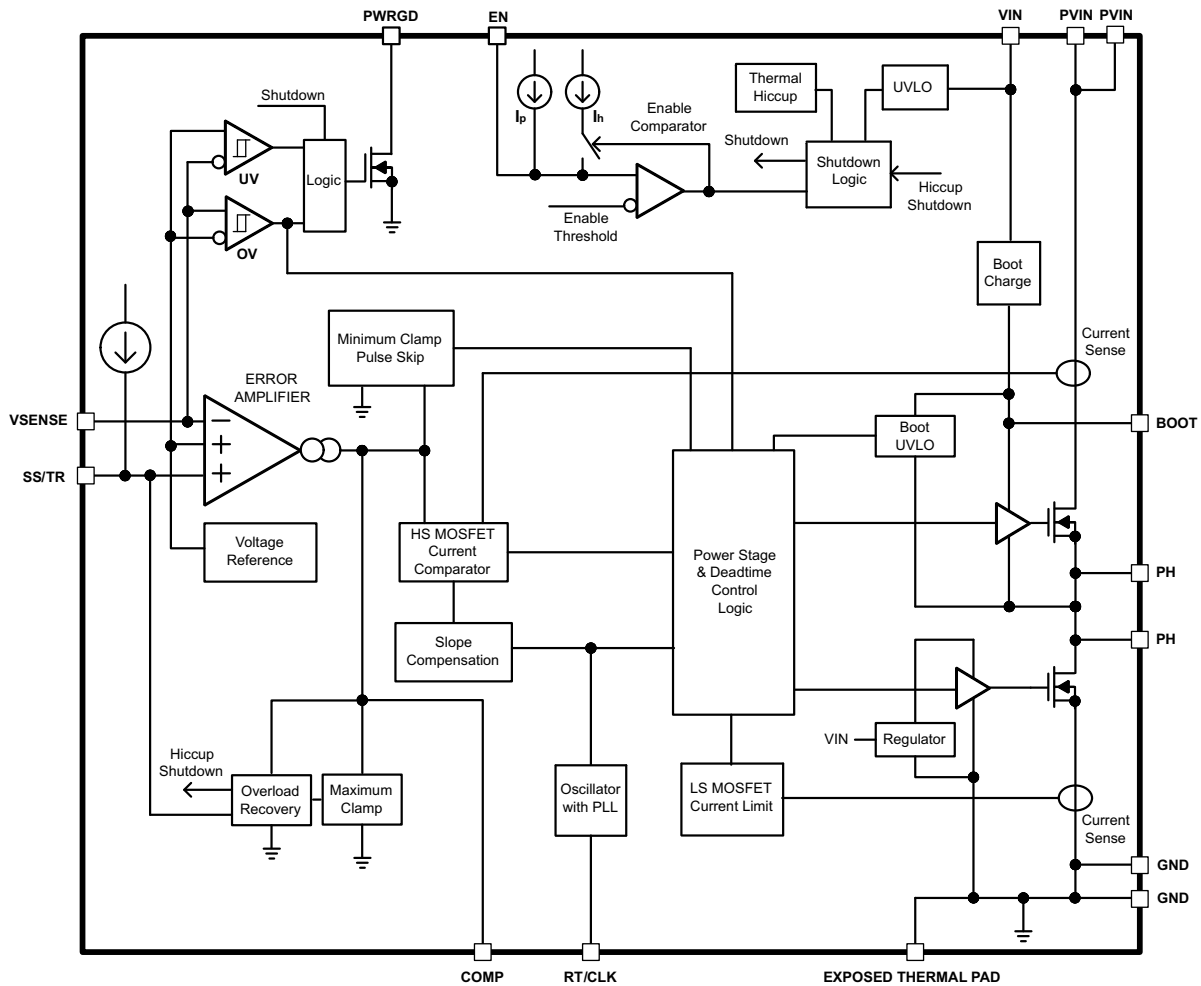

Copyright © 2016, Texas Instruments Incorporated

7.3 Feature Description

7.3.1 VIN and Power VIN Pins (VIN and PVIN)

The device allows for a variety of applications by using the VIN and PVIN pins together or separately. The VIN pin voltage supplies the internal control circuits of the device. The PVIN pin voltage provides the input voltage to the power converter system.

If tied together, the input voltage for VIN and PVIN can range from 4.5 V to 17 V. If using the VIN separately from PVIN, the VIN pin must be between 4.5 V and 17 V, and the PVIN pin can range from as low as 1.6 V to 17 V. A voltage divider connected to the EN pin can adjust the either input voltage UVLO appropriately. Adjusting the input voltage UVLO on the PVIN pin helps to provide consistent power up behavior.

7.3.2 Voltage Reference

The voltage reference system produces a precise $\pm 1\%$ voltage reference over temperature by scaling the output of a temperature stable bandgap circuit.

Feature Description (continued)

7.3.3 Adjusting the Output Voltage

The output voltage is set with a resistor divider from the output (VOUT) to the VSENSE pin. It is recommended to use 1% tolerance or better divider resistors. Referring to the application schematic of [Figure 31](#), start with a 10 kΩ for R6 and use [Equation 1](#) to calculate R5. To improve efficiency at light loads consider using larger value resistors. If the values are too high the regulator is more susceptible to noise and voltage errors from the VSENSE input current are noticeable.

$$R5 = \frac{V_o - V_{ref}}{V_{ref}} R6$$

where

- $V_{ref} = 0.6 \text{ V}$ (1)

The minimum output voltage and maximum output voltage can be limited by the minimum on time of the high-side MOSFET and bootstrap voltage (BOOT-PH voltage) respectively. More discussions are located in [Minimum Output Voltage](#) and [Bootstrap Voltage \(BOOT\) and Low Dropout Operation](#).

7.3.4 Safe Start-up into Pre-Biased Outputs

The device has been designed to prevent the low-side MOSFET from discharging a pre-biased output. During monotonic pre-biased startup, the low-side MOSFET is not allowed to sink current until the SS/TR pin voltage is higher than 1.4 V.

7.3.5 Error Amplifier

The device uses a transconductance error amplifier. The error amplifier compares the VSENSE pin voltage to the lower of the SS/TR pin voltage or the internal 0.6 V voltage reference. The transconductance of the error amplifier is 1300 μA/V during normal operation. The frequency compensation network is connected between the COMP pin and ground.

7.3.6 Slope Compensation

The device adds a compensating ramp to the switch current signal. This slope compensation prevents sub-harmonic oscillations. The available peak inductor current remains constant over the full duty cycle range.

7.3.7 Enable and Adjusting Undervoltage Lockout

The EN pin provides electrical on/off control of the device. Once the EN pin voltage exceeds the threshold voltage, the device starts operation. If the EN pin voltage is pulled below the threshold voltage, the regulator stops switching and enters low Iq state.

The EN pin has an internal pullup current source, allowing the user to float the EN pin for enabling the device. If an application requires controlling the EN pin, use open drain or open collector output logic to interface with the pin.

The device implements internal UVLO circuitry on the VIN pin. The device is disabled when the VIN pin voltage falls below the internal VIN UVLO threshold. The internal VIN UVLO threshold has a hysteresis of 150 mV.

If an application requires either a higher UVLO threshold on the VIN pin or a secondary UVLO on the PVIN, in split rail applications, then the EN pin can be configured as shown in [Figure 17](#), [Figure 18](#) and [Figure 19](#). When using the external UVLO function it is recommended to set the hysteresis to be greater than 500 mV.

The EN pin has a small pullup current I_p which sets the default state of the pin to enable when no external components are connected. The pullup current is also used to control the voltage hysteresis for the UVLO function since it increases by I_h once the EN pin crosses the enable threshold. The UVLO thresholds can be calculated using [Equation 2](#) and [Equation 3](#).

Feature Description (continued)

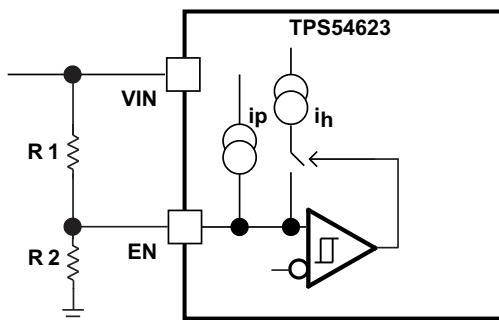

Copyright © 2016, Texas Instruments Incorporated

Figure 17. Adjustable VIN Undervoltage Lockout

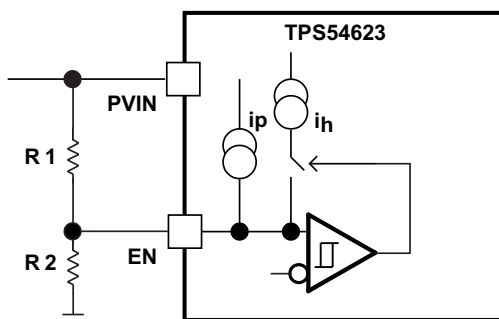

Copyright © 2016, Texas Instruments Incorporated

Figure 18. Adjustable PVIN Undervoltage Lockout, $V_{IN} \geq 4.5\text{ V}$

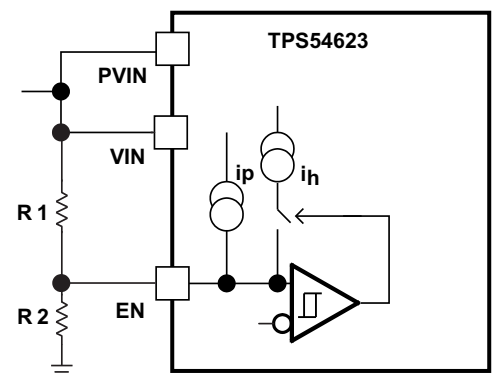

Copyright © 2016, Texas Instruments Incorporated

Figure 19. Adjustable VIN and PVIN Undervoltage Lockout

Feature Description (continued)

$$R1 = \frac{V_{START} \left(\frac{V_{ENFALLING}}{V_{ENRISING}} \right) - V_{STOP}}{I_p \left(1 - \frac{V_{ENFALLING}}{V_{ENRISING}} \right) + I_h} \quad (2)$$

$$R2 = \frac{R1 \times V_{ENFALLING}}{V_{STOP} - V_{ENFALLING} + R1(I_p + I_h)}$$

where

- $I_h = 3.4 \mu\text{A}$
 - $I_p = 1.15 \mu\text{A}$
 - $V_{ENRISING} = 1.21 \text{ V}$
 - $V_{ENFALLING} = 1.17 \text{ V}$
- (3)

7.3.8 Slow Start (SS/TR)

The device uses the lower voltage of the internal voltage reference or the SS/TR pin voltage as the reference voltage and regulates the output accordingly. A capacitor on the SS/TR pin to ground implements a slow start time. The device has an internal pullup current source of 2.3 μA that charges the external slow start capacitor. The calculations for the slow start time (t_{SS} , 10% to 90%) and slow start capacitor (C_{SS}) are shown in [Equation 4](#). The voltage reference (V_{ref}) is 0.6 V and the slow start charge current (I_{SS}) is 2.3 μA .

$$t_{SS} \text{ (ms)} = \frac{C_{SS} \text{ (nF)} \times V_{ref} \text{ (V)}}{I_{SS} \text{ (\mu A)}} \quad (4)$$

When the input UVLO is triggered, the EN pin is pulled below 1.21 V, or a thermal shutdown event occurs the device stops switching and enters low current operation. At the subsequent power up, when the shutdown condition is removed, the device does not start switching until it has discharged its SS/TR pin to ground ensuring proper soft start behavior.

7.3.9 Power Good (PWRGD)

The PWRGD pin is an open drain output. Once the VSENSE pin is between 94% and 104% of the internal voltage reference the PWRGD pin pull-down is de-asserted and the pin floats. It is recommended to use a pullup resistor between the values of 10 k Ω and 100 k Ω to a voltage source that is 5.5 V or less. The PWRGD is in a defined state once the VIN input voltage is greater than 1 V but with reduced current sinking capability. The PWRGD achieves full current sinking capability once the VIN input voltage is above 4.5 V.

The PWRGD pin is pulled low when VSENSE is lower than 92% or greater than 106% of the nominal internal reference voltage. Also, the PWRGD is pulled low, if the input UVLO or thermal shutdown are asserted, the EN pin is pulled low or the SS/TR pin is below 1.4 V.

7.3.10 Bootstrap Voltage (BOOT) and Low Dropout Operation

The device has an integrated boot regulator, and requires a small ceramic capacitor between the BOOT and PH pins to provide the gate drive voltage for the high-side MOSFET. The boot capacitor is charged when the BOOT pin voltage is less than VIN and BOOT-PH voltage is below regulation. The value of this ceramic capacitor should be 0.1 μF . A ceramic capacitor with an X7R or X5R grade dielectric with a voltage rating of 10 V or higher is recommended because of the stable characteristics over temperature and voltage.

To improve drop out, the device is designed to operate at 100% duty cycle as long as the BOOT to PH pin voltage is greater than the BOOT-PH UVLO threshold which is typically 2.1 V. When the voltage between BOOT and PH drops below the BOOT-PH UVLO threshold the high-side MOSFET is turned off and the low-side MOSFET is turned on allowing the boot capacitor to be recharged. In applications with split input voltage rails 100% duty cycle operation can be achieved as long as $(V_{IN} - P_{VIN}) > 4 \text{ V}$.

Feature Description (continued)

7.3.11 Sequencing (SS/TR)

Many of the common power supply sequencing methods can be implemented using the SS/TR, EN and PWRGD pins.

The sequential method is illustrated in [Figure 20](#) using two TPS54623 devices. The power good of the first device is coupled to the EN pin of the second device, which enables the second power supply once the primary supply reaches regulation.

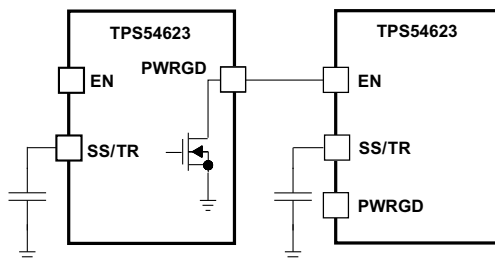

Copyright © 2016, Texas Instruments Incorporated

Figure 20. Sequential Start-Up Sequence

[Figure 21](#) shows the method implementing ratio-metric sequencing by connecting the SS/TR pins of two devices together. The regulator outputs ramp up and reach regulation at the same time. When calculating the slow start time the pullup current source must be doubled in [Equation 4](#).

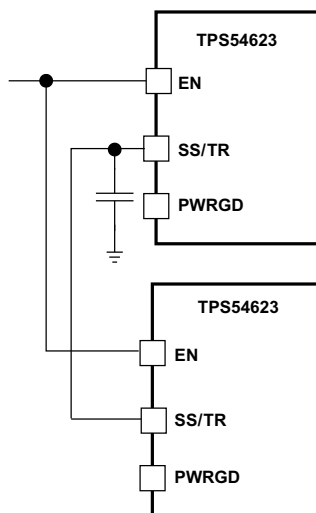

Copyright © 2016, Texas Instruments Incorporated

Figure 21. Ratiometric Start-Up Sequence

Ratio-metric and simultaneous power supply sequencing can be implemented by connecting the resistor network of R1 and R2 shown in [Figure 22](#) to the output of the power supply that needs to be tracked or another voltage reference source. Using [Equation 5](#) and [Equation 6](#), the tracking resistors can be calculated to initiate the Vout2 slightly before, after or at the same time as Vout1. [Equation 7](#) is the voltage difference between Vout1 and Vout2.

To design a ratio-metric start up in which the Vout2 voltage is slightly greater than the Vout1 voltage when Vout2 reaches regulation, use a negative number in [Equation 5](#) and [Equation 6](#) for deltaV. [Equation 7](#) results in a positive number for applications where the Vout2 is slightly lower than Vout1 when Vout2 regulation is achieved. .

Feature Description (continued)

The ΔV variable is zero volt for simultaneous sequencing. To minimize the effect of the inherent SS/TR to VSENSE offset ($V_{ssoffset}$, 29 mV) in the slow start circuit and the offset created by the pullup current source (I_{ss} , 2.3 μA) and tracking resistors, the $V_{ssoffset}$ and I_{ss} are included as variables in the equations.

To ensure proper operation of the device, the calculated R1 value from Equation 5 must be greater than the value calculated in Equation 8.

$$R1 = \frac{V_{out2} + \Delta V}{V_{ref}} \times \frac{V_{ssoffset}}{I_{ss}} \quad (5)$$

$$R2 = \frac{V_{ref} \times R1}{V_{out2} + \Delta V - V_{ref}} \quad (6)$$

$$\Delta V = V_{out1} - V_{out2} \quad (7)$$

$$R1 > 2800 \times V_{out1} - 180 \times \Delta V \quad (8)$$

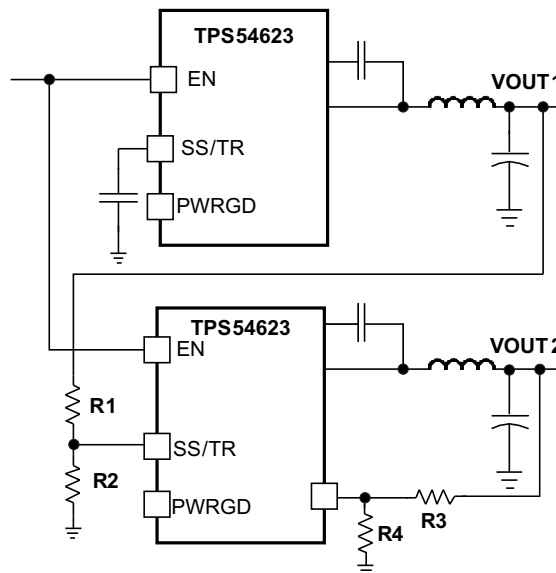

Copyright © 2016, Texas Instruments Incorporated

Figure 22. Ratiometric and Simultaneous Start-up Sequence

There are two final considerations when using a resistor divider to the SS/TR pin for simultaneous start-up. First, as described in *Power Good (PWRGD)*, for the PWRGD output to be active the SS/TR voltage must be above 1.4 V. The external divider may prevent the SS/TR voltage from charging above the threshold. For the SS/TR pin to charge above the threshold, an external MOSFET may be needed to disconnect the resistor divider or modify the resistor divider ratio after start-up is complete. The PWRGD pin of the $V_{OUT(1)}$ converter could be used to turn on or turn off the external MOSFET. Second, a pre-bias on $V_{OUT(1)}$ may prevent $V_{OUT(2)}$ from turning on. When the TPS54623 is enabled, an internal 700- Ω MOSFET at the SS/TR pin turns on to discharge the SS/TR voltage as described in *Slow Start (SS/TR)*. The SS/TR pin voltage must discharge below 20 mV before the TPS54623 starts up. If the upper resistor at the SS/TR pin is too small, the SS/TR pin does not discharge below the threshold, and $V_{OUT(2)}$ does not ramp up. The upper resistor in the SS/TR divider may need to be increased to allow the SS/TR pin to discharge below the threshold.

Feature Description (continued)

7.3.12 Output Overvoltage Protection (OVP)

The device incorporates an output overvoltage protection (OVP) circuit to minimize output voltage overshoot. For example, when the power supply output is overloaded the error amplifier compares the actual output voltage to the internal reference voltage. If the VSENSE pin voltage is lower than the internal reference voltage for a considerable time, the output of the error amplifier demands maximum output current. Once the condition is removed, the regulator output rises and the error amplifier output transitions to the steady state voltage. In some applications with small output capacitance, the power supply output voltage can respond faster than the error amplifier. This leads to the possibility of an output overshoot. The OVP feature minimizes the overshoot by comparing the VSENSE pin voltage to the OVP threshold. If the VSENSE pin voltage is greater than the OVP threshold the high-side MOSFET is turned off preventing current from flowing to the output and minimizing output overshoot. When the VSENSE voltage drops lower than the OVP threshold, the high-side MOSFET is allowed to turn on at the next clock cycle.

7.3.13 Overcurrent Protection

The device is protected from overcurrent conditions by cycle-by-cycle current limiting on both the high-side MOSFET and the low-side MOSFET.

7.3.13.1 High-side MOSFET Overcurrent Protection

The device implements current mode control which uses the COMP pin voltage to control the turnoff of the high-side MOSFET and the turnon of the low-side MOSFET on a cycle by cycle basis. Each cycle the switch current and the current reference generated by the COMP pin voltage are compared, when the peak switch current intersects the current reference the high-side switch is turned off.

7.3.13.2 Low-side MOSFET Overcurrent Protection

While the low-side MOSFET is turned on its conduction current is monitored by the internal circuitry. During normal operation the low-side MOSFET sources current to the load. At the end of every clock cycle, the low-side MOSFET sourcing current is compared to the internally set low-side sourcing current limit. If the low-side sourcing current is exceeded the high-side MOSFET is not turned on and the low-side MOSFET stays on for the next cycle. The high-side MOSFET is turned on again when the low-side current is below the low-side sourcing current limit at the start of a cycle.

The low-side MOSFET may also sink current from the load. If the low-side sinking current limit is exceeded the low-side MOSFET is turned off immediately for the rest of that clock cycle. In this scenario both MOSFETs are off until the start of the next cycle.

Furthermore, if an output overload condition (as measured by the COMP pin voltage) has lasted for more than the hiccup wait time which is programmed for 512 switching cycles, the device shuts down itself and restart after the hiccup time of 16384 cycles. The hiccup mode helps to reduce the device power dissipation under severe overcurrent conditions.

7.3.14 Thermal Shutdown

The internal thermal shutdown circuitry forces the device to stop switching if the junction temperature exceeds 175°C typically. Once the junction temperature drops below 165°C typically, the internal thermal hiccup timer will start to count. The device reinitiates the power up sequence after the built-in thermal shutdown hiccup time (16384 cycles) is over.

7.3.15 Small Signal Model for Loop Response

[Figure 23](#) shows an equivalent model for the device control loop which can be modeled in a circuit simulation program to check frequency response and transient responses. The error amplifier is a transconductance amplifier with a gm of 1300 μ A/V. The error amplifier can be modeled using an ideal voltage controlled current source. The resistor R_{oea} (2.38 M Ω) and capacitor C_{oea} (20.7 pF) model the open loop gain and frequency response of the error amplifier. The 1-mV ac voltage source between the nodes a and b effectively breaks the control loop for the frequency response measurements. Plotting a/c and c/b show the small signal responses of the power stage and frequency compensation respectively. Plotting a/b shows the small signal response of the overall loop. The dynamic loop response can be checked by replacing the R_L with a current source with the appropriate load step amplitude and step rate in a time domain analysis.

Feature Description (continued)

Figure 23. Small Signal Model for Loop Response
7.3.16 Simple Small Signal Model for Peak Current Mode Control

Figure 24 is a simple small signal model that can be used to understand how to design the frequency compensation. The device power stage can be approximated to a voltage controlled current source (duty cycle modulator) supplying current to the output capacitor and load resistor. The control to output transfer function is shown in Equation 9 and consists of a dc gain, one dominant pole and one ESR zero. The quotient of the change in switch current and the change in COMP pin voltage (node c in Figure 23) is the power stage transconductance ($g_{m_{ps}}$) which is 16 A/V for the device. The DC gain of the power stage is the product of $g_{m_{ps}}$ and the load resistance R_L as shown in Equation 10 with resistive loads. As the load current increases, the DC gain decreases. This variation with load may seem problematic at first glance, but fortunately the dominant pole moves with load current (see Equation 11). The combined effect is highlighted by the dashed line in Figure 25. As the load current decreases, the gain increases and the pole frequency lowers, keeping the 0-dB crossover frequency the same for the varying load conditions which makes it easier to design the frequency compensation.

Figure 24. Simplified Small Signal Model for Peak Current Mode Control

Feature Description (continued)

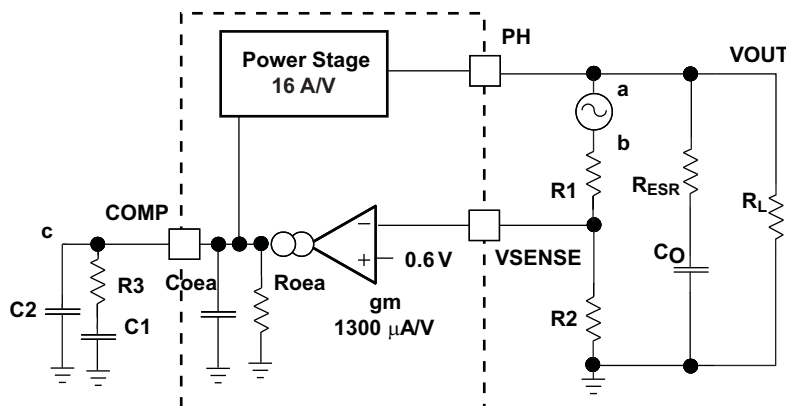
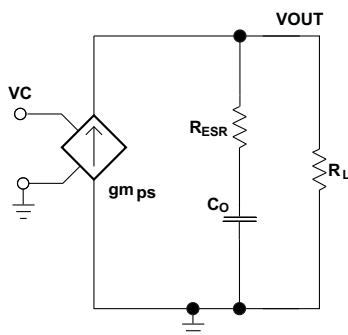
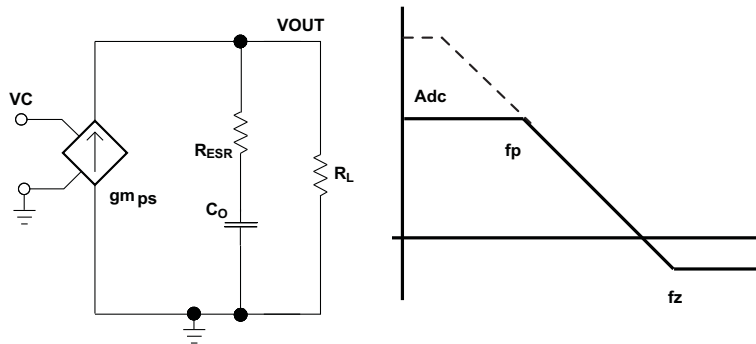

Figure 25. Simplified Frequency Response for Peak Current Mode Control

$$\frac{V_{OUT}}{V_C} = A_{dc} \times \frac{\left(1 + \frac{s}{2\pi \times f_z}\right)}{\left(1 + \frac{s}{2\pi \times f_p}\right)} \tag{9}$$

$$A_{dc} = g_{m_{ps}} \times R_L \tag{10}$$

$$f_p = \frac{1}{C_O \times R_L \times 2\pi} \tag{11}$$

$$f_z = \frac{1}{C_O \times R_{ESR} \times 2\pi}$$

where

- $g_{m_{ea}}$ is the GM amplifier gain (1300 $\mu A/V$)
 - $g_{m_{ps}}$ is the power stage gain (16 A/V)
 - R_L is the load resistance
 - C_O is the output capacitance
 - R_{ESR} is the equivalent series resistance of the output capacitor
- (12)

7.3.17 Small Signal Model for Frequency Compensation

The device uses a transconductance amplifier for the error amplifier and readily supports two of the commonly used Type II compensation circuits and a Type III frequency compensation circuit, as shown in Figure 26. In Type 2A, one additional high frequency pole, C6, is added to attenuate high frequency noise. In Type III, one additional capacitor, C11, is added to provide a phase boost at the crossover frequency. See [Designing Type III Compensation for Current Mode Step-Down Converters](#) for a complete explanation of Type III compensation.

The design guidelines below are provided for advanced users who prefer to compensate using the general method. The below equations only apply to designs whose ESR zero is above the bandwidth of the control loop. This is usually true with ceramic output capacitors. See [Typical Application](#) for a step-by-step design procedure using higher ESR output capacitors with lower ESR zero frequencies.

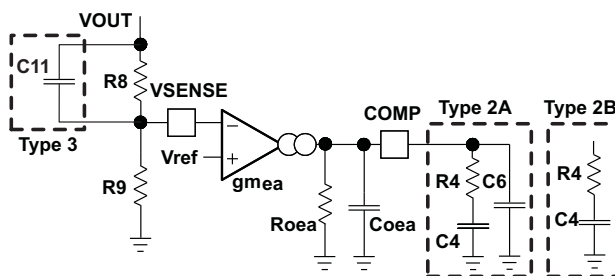
Feature Description (continued)

Figure 26. Types of Frequency Compensation

The general design guidelines for device loop compensation are as follows:

1. Determine the crossover frequency, f_c . A good starting point is $1/10^{\text{th}}$ of the switching frequency, f_{sw} .
2. R_4 can be determined by [Equation 13](#).

$$R_4 = \frac{2\pi \times f_c \times V_{OUT} \times C_o}{g_{m_{ea}} \times V_{ref} \times g_{m_{ps}}}$$

where

- $g_{m_{ea}}$ is the GM amplifier gain (1300 $\mu\text{A/V}$)
- $g_{m_{ps}}$ is the power stage gain (16 A/V)
- V_{ref} is the reference voltage (0.6 V)

(13)

3. Place a compensation zero at the dominant pole: $\left(f_p = \frac{1}{C_o \times R_L \times 2\pi} \right)$

C_4 can be determined by [Equation 14](#).

$$C_4 = \frac{R_L \times C_o}{R_4}$$

(14)

4. C_6 is optional. It can be used to cancel the zero from the equivalent series resistance (ESR) of the output capacitor C_o .

$$C_6 = \frac{R_{ESR} \times C_o}{R_4}$$

(15)

5. Type III compensation can be implemented with the addition of one capacitor, C_{11} . This allows for slightly higher loop bandwidths and higher phase margins. If used, C_{11} is calculated from [Equation 16](#).

$$C_{11} = \frac{1}{(2 \cdot \pi \cdot R_8 \cdot f_c)}$$

(16)

7.4 Device Functional Modes

7.4.1 Fixed Frequency PWM Control

The device uses a adjustable fixed frequency, peak current mode control. The output voltage is compared through external resistors on the VSENSE pin to an internal voltage reference by an error amplifier which drives the COMP pin. An internal oscillator initiates the turn on of the high-side power switch. The error amplifier output is converted into a current reference which compares to the high-side power switch current. When the power switch current reaches current reference generated by the COMP voltage level the high-side power switch is turned off and the low-side power switch is turned on.

7.4.2 Continuous Current Mode Operation (CCM)

As a synchronous buck converter, the device normally works in CCM (Continuous Conduction Mode) under load conditions where the minimum inductor valley current is higher than 0 A.

7.4.3 Light Load Efficiency Operation

The TPS54623 operates in pulse skip mode (see [Figure 28](#)) at light load currents to improve efficiency by reducing switching and gate drive losses. The TPS54623 is designed so that if the output voltage is within regulation and the peak switch current at the end of any switching cycle is below the pulse skipping current threshold, the device enters pulse skip mode. This current threshold is the current level corresponding to a nominal COMP voltage of 250 mV.

When in pulse skip mode, the COMP pin voltage is clamped and the high side MOSFET is inhibited. Further decreases in load current or in output voltage can not drive the COMP pin below this clamp voltage level.

Since the device is not switching, the output voltage begins to decay. As the voltage control loop compensates for the falling output voltage, the COMP pin voltage begins to rise. At this time, the high side MOSFET is enabled and a switching pulse initiates on the next switching cycle. The peak current is set by the COMP pin voltage. The output voltage re-charges the regulated value, then the peak switch current starts to decrease, and eventually falls below the pulse skip mode threshold at which time the device again enters pulse skip mode.

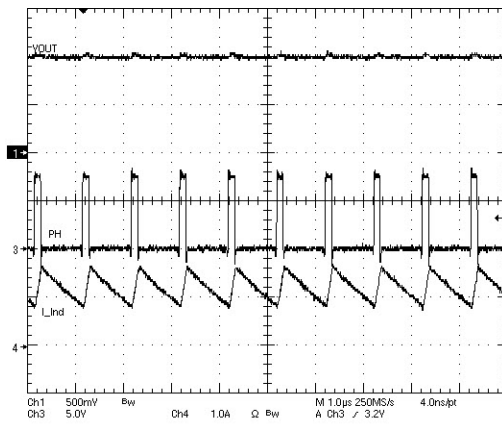

Figure 27. TPS54623 Operation In Current Mode

Device Functional Modes (continued)

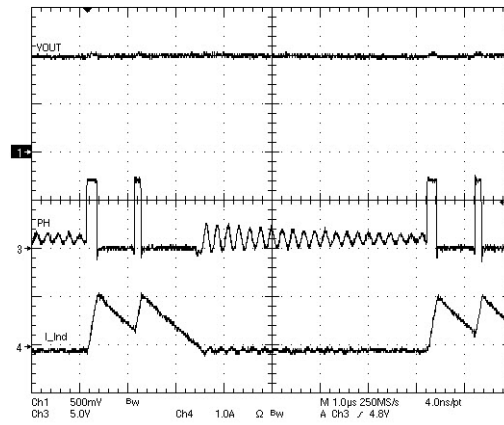

Figure 28. TPS54623 Operation In Pulse Skipping Mode

7.4.4 Adjustable Switching Frequency and Synchronization (RT/CLK)

The RT/CLK pin can be used to set the switching frequency of the device in two modes.

In RT mode, a resistor (RT resistor) is connected between the RT/CLK pin and GND. The switching frequency of the device is adjustable from 200 kHz to 1600 kHz by placing a maximum of 240 kΩ and minimum of 29 kΩ respectively. In CLK mode, an external clock is connected directly to the RT/CLK pin. The device is synchronized to the external clock frequency with PLL.

The CLK mode overrides the RT mode. The device is able to detect the proper mode automatically and switch from the RT mode to CLK mode.

7.4.4.1 Adjustable Switching Frequency (RT Mode)

To determine the RT resistance for a given switching frequency, use Equation 17 or the curve in Figure 29. To reduce the solution size one would set the switching frequency as high as possible, but tradeoffs of the supply efficiency and minimum controllable on time should be considered.

$$R_{rt}(k\Omega) = 48000 \cdot F_{sw}(\text{kHz})^{-0.997} - 2 \tag{17}$$

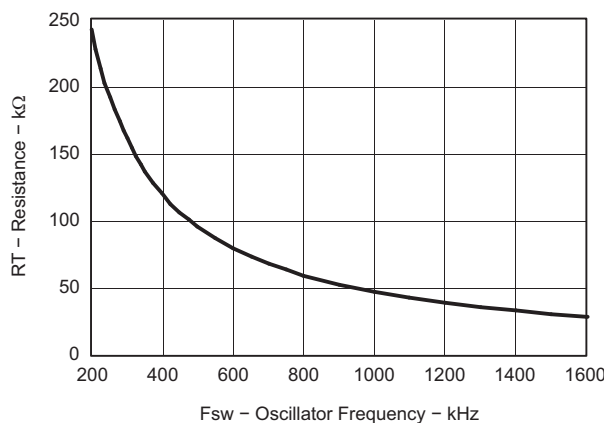

Figure 29. RT Set Resistor vs Switching Frequency

7.4.4.2 Synchronization (CLK mode)

An internal phase locked loop (PLL) has been implemented to allow synchronization between 200 kHz and 1600 kHz, and to easily switch from RT mode to CLK mode.

Device Functional Modes (continued)

To implement the synchronization feature, connect a square wave clock signal to the RT/CLK pin with a duty cycle between 20% to 80%. The clock signal amplitude must transition lower than 0.8 V and higher than 2 V. The start of the switching cycle is synchronized to the falling edge of RT/CLK pin.

In applications where both RT mode and CLK mode are needed, the device can be configured as shown in Figure 30. Before the external clock is present, the device works in RT mode and the switching frequency is set by RT resistor. When the external clock is present, the CLK mode overrides the RT mode. The first time the SYNC pin is pulled above the RT/CLK high threshold (2 V), the device switches from the RT mode to the CLK mode and the RT/CLK pin becomes high impedance as the PLL starts to lock onto the frequency of the external clock. It is not recommended to switch from the CLK mode back to the RT mode because the internal switching frequency drops to 100 kHz first before returning to the switching frequency set by RT resistor.

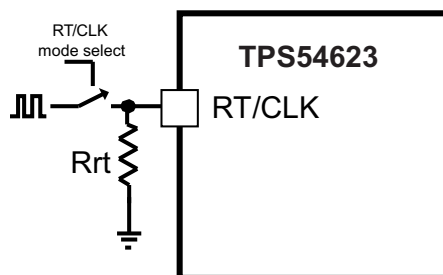

Copyright © 2016, Texas Instruments Incorporated

Figure 30. Works with Both RT Mode and CLK Mode

8 Application and Implementation

NOTE

Information in the following applications sections is not part of the TI component specification, and TI does not warrant its accuracy or completeness. TI's customers are responsible for determining suitability of components for their purposes. Customers should validate and test their design implementation to confirm system functionality.

8.1 Application Information

8.1.1 Fast Transient Considerations

In applications where fast transient responses are important, Type III frequency compensation can be used instead of the traditional Type II frequency compensation.

For more information about Type II and Type III frequency compensation circuits, see *Designing Type III Compensation for Current Mode Step-Down Converters* (SLVA352) and Design Calculator (SLVC219).

8.2 Typical Application

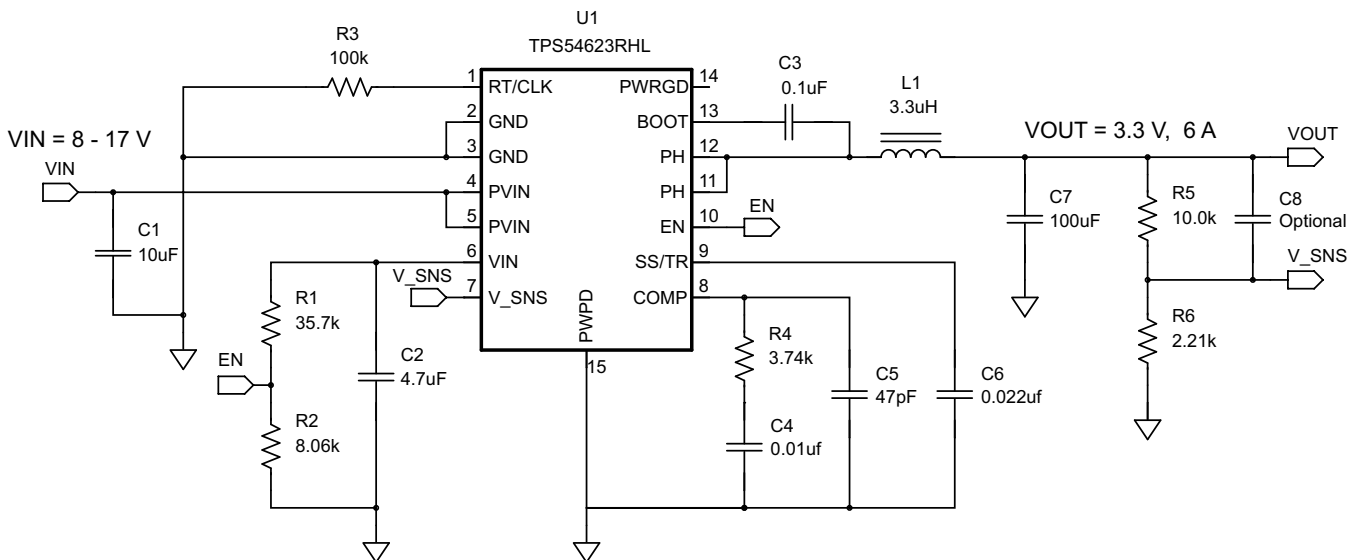

Copyright © 2016, Texas Instruments Incorporated

Figure 31. Typical Application Circuit

8.2.1 Design Requirements

This example details the design of a high frequency switching regulator design using ceramic output capacitors. A few parameters must be known in order to start the design process. These parameters are typically determined at the system level. For this example, start with the parameters in [Table 1](#).

Typical Application (continued)

Table 1. Design Parameters

PARAMETER	VALUE
Output voltage	3.3 V
Output current	6 A
Transient response 1-A load step	$\Delta V_{OUT} = 5\%$
Input voltage	12 V nominal, 8 V to 17 V
Output voltage ripple	33 mV p-p
Start input voltage (rising V_{IN})	6.528 V
Stop input voltage (falling V_{IN})	6.19 V
Switching frequency	480 kHz

8.2.2 Detailed Design Procedure

8.2.2.1 Custom Design With WEBENCH® Tools

[Click here](#) to create a custom design using the TPS54623 device with the WEBENCH® Power Designer.

1. Start by entering the input voltage (V_{IN}), output voltage (V_{OUT}), and output current (I_{OUT}) requirements.
2. Optimize the design for key parameters such as efficiency, footprint, and cost using the optimizer dial.
3. Compare the generated design with other possible solutions from Texas Instruments.

The WEBENCH Power Designer provides a customized schematic along with a list of materials with real-time pricing and component availability.

In most cases, these actions are available:

- Run electrical simulations to see important waveforms and circuit performance
- Run thermal simulations to understand board thermal performance
- Export customized schematic and layout into popular CAD formats
- Print PDF reports for the design, and share the design with colleagues

Get more information about WEBENCH tools at www.ti.com/WEBENCH.

8.2.2.2 Operating Frequency

The first step is to decide on a switching frequency for the regulator. There is a trade off between higher and lower switching frequencies. Higher switching frequencies may produce smaller a solution size using lower valued inductors and smaller output capacitors compared to a power supply that switches at a lower frequency. However, the higher switching frequency causes extra switching losses, which hurt the converter's efficiency and thermal performance. In this design, a moderate switching frequency of 480 kHz is selected to achieve both a small solution size and a high efficiency operation.

8.2.2.3 Output Inductor Selection

To calculate the value of the output inductor, use [Equation 18](#). $KIND$ is a coefficient that represents the amount of inductor ripple current relative to the maximum output current. The inductor ripple current is filtered by the output capacitor. Therefore, choosing high inductor ripple currents impact the selection of the output capacitor since the output capacitor must have a ripple current rating equal to or greater than the inductor ripple current. In general, the inductor ripple value is at the discretion of the designer; however, $KIND$ is normally from 0.1 to 0.3 for the majority of applications.

$$L1 = \frac{V_{inmax} - V_{out}}{I_o \cdot KIND} \cdot \frac{V_{out}}{V_{inmax} \cdot f_{sw}} \quad (18)$$

For this design example, use $KIND = 0.3$ and the inductor value is calculated to be 3.08 μH . For this design, a nearest standard value was chosen: 3.3 μH . For the output filter inductor, it is important that the RMS current and saturation current ratings not be exceeded. The RMS and peak inductor current can be found from [Equation 20](#) and [Equation 21](#).

$$I_{\text{ripple}} = \frac{V_{\text{inmax}} - V_{\text{out}}}{L1} \cdot \frac{V_{\text{out}}}{V_{\text{inmax}} \cdot f_{\text{sw}}} \quad (19)$$

$$I_{\text{Lrms}} = \sqrt{I_{\text{o}}^2 + \frac{1}{12} \cdot \left(\frac{V_{\text{o}} \cdot (V_{\text{inmax}} - V_{\text{o}})}{V_{\text{inmax}} \cdot L1 \cdot f_{\text{sw}}} \right)^2} \quad (20)$$

$$I_{\text{Lpeak}} = I_{\text{out}} + \frac{I_{\text{ripple}}}{2} \quad (21)$$

For this design, the RMS inductor current is 6.02 A and the peak inductor current is 6.84 A. The chosen inductor is a Coilcraft MSS1048 series 3.3 μH . It has a saturation current rating of 7.38 A and a RMS current rating of 7.22 A.

The current flowing through the inductor is the inductor ripple current plus the output current. During power up, faults or transient load conditions, the inductor current can increase above the calculated peak inductor current level calculated above. In transient conditions, the inductor current can increase up to the switch current limit of the device. For this reason, the most conservative approach is to specify an inductor with a saturation current rating equal to or greater than the switch current limit rather than the peak inductor current.

8.2.2.4 Output Capacitor Selection

There are three primary considerations for selecting the value of the output capacitor. The output capacitor determines the modulator pole, the output voltage ripple, and how the regulator responds to a large change in load current. The output capacitance needs to be selected based on the more stringent of these three criteria.

The desired response to a large change in the load current is the first criteria. The output capacitor needs to supply the load with current when the regulator can not. This situation would occur if there are desired hold-up times for the regulator where the output capacitor must hold the output voltage above a certain level for a specified amount of time after the input power is removed. The regulator is also temporarily not able to supply sufficient output current if there is a large, fast increase in the current needs of the load such as a transition from no load to full load. The regulator usually needs two or more clock cycles for the control loop to see the change in load current and output voltage and adjust the duty cycle to react to the change. The output capacitor must be sized to supply the extra current to the load until the control loop responds to the load change. The output capacitance must be large enough to supply the difference in current for 2 clock cycles while only allowing a tolerable amount of droop in the output voltage. Equation 22 shows the minimum output capacitance necessary to accomplish this.

$$C_{\text{o}} > \frac{2 \cdot \Delta I_{\text{out}}}{f_{\text{sw}} \cdot \Delta V_{\text{out}}} \quad (22)$$

Where ΔI_{out} is the change in output current, f_{sw} is the regulators switching frequency and ΔV_{out} is the allowable change in the output voltage. For this example, the transient load response is specified as a 5% change in V_{out} for a load step of 1 A. For this example, $\Delta I_{\text{out}} = 3.0$ A and $\Delta V_{\text{out}} = 0.05 \times 3.3 = 0.165$ V. Using these numbers gives a minimum capacitance of 75.8 μF . This value does not take the ESR of the output capacitor into account in the output voltage change. For ceramic capacitors, the ESR is usually small enough to ignore in this calculation.

Equation 23 calculates the minimum output capacitance needed to meet the output voltage ripple specification. Where f_{sw} is the switching frequency, V_{ripple} is the maximum allowable output voltage ripple, and I_{ripple} is the inductor ripple current. In this case, the maximum output voltage ripple is 33 mV. Under this requirement, Equation 23 yields 13.2 μF .

$$C_{\text{o}} > \frac{1}{8 \cdot f_{\text{sw}}} \cdot \frac{1}{\frac{V_{\text{ripple}}}{I_{\text{ripple}}}} \quad (23)$$

Equation 24 calculates the maximum ESR an output capacitor can have to meet the output voltage ripple specification. Equation 24 indicates the ESR should be less than 19.7 m Ω . In this case, the ceramic caps' ESR is much smaller than 19.7 m Ω .

$$\text{Resr} < \frac{V_{\text{ripple}}}{I_{\text{ripple}}} \quad (24)$$

Additional capacitance de-ratings for aging, temperature and DC bias should be factored in which increases this minimum value. For this example, a 100- μF 6.3-V X5R ceramic capacitor with 3 $\text{m}\Omega$ of ESR is used. Capacitors generally have limits to the amount of ripple current they can handle without failing or producing excess heat. An output capacitor that can support the inductor ripple current must be specified. Some capacitor data sheets specify the root mean square (RMS) value of the maximum ripple current. Equation 25 can be used to calculate the RMS ripple current the output capacitor needs to support. For this application, Equation 25 yields 485 mA.

$$I_{\text{corms}} = \frac{V_{\text{out}} \cdot (V_{\text{inmax}} - V_{\text{out}})}{\sqrt{12} \cdot V_{\text{inmax}} \cdot L_1 \cdot f_{\text{sw}}} \quad (25)$$

8.2.2.5 Input Capacitor Selection

The TPS54623 requires a high quality ceramic, type X5R or X7R, input decoupling capacitor of at least 4.7 μF of effective capacitance on the PVIN input voltage pins and 4.7 μF on the Vin input voltage pin. In some applications additional bulk capacitance may also be required for the PVIN input. The effective capacitance includes any DC bias effects. The voltage rating of the input capacitor must be greater than the maximum input voltage. The capacitor must also have a ripple current rating greater than the maximum input current ripple of the TPS54623. The input ripple current can be calculated using Equation 26.

$$I_{\text{cirms}} = I_{\text{out}} \cdot \sqrt{\frac{V_{\text{out}}}{V_{\text{inmin}}} \cdot \frac{(V_{\text{inmin}} - V_{\text{out}})}{V_{\text{inmin}}}} \quad (26)$$

The value of a ceramic capacitor varies significantly over temperature and the amount of DC bias applied to the capacitor. The capacitance variations due to temperature can be minimized by selecting a dielectric material that is stable over temperature. X5R and X7R ceramic dielectrics are usually selected for power regulator capacitors because they have a high capacitance to volume ratio and are fairly stable over temperature. The output capacitor must also be selected with the DC bias taken into account. The capacitance value of a capacitor decreases as the DC bias across a capacitor increases. For this example design, a ceramic capacitor with at least a 25 V voltage rating is required to support the maximum input voltage. For this example, one 10 μF and one 4.7 μF 25 V capacitors in parallel have been selected as the VIN and PVIN inputs are tied together so the TPS54623 may operate from a single supply. The input capacitance value determines the input ripple voltage of the regulator. The input voltage ripple can be calculated using Equation 27. Using the design example values, $I_{\text{outmax}} = 6 \text{ A}$, $C_{\text{in}} = 14.7 \mu\text{F}$, $f_{\text{sw}} = 480 \text{ kHz}$, yields an input voltage ripple of 213 mV and a RMS input ripple current of 2.95 A.

$$\Delta V_{\text{in}} = \frac{I_{\text{outmax}} \cdot 0.25}{C_{\text{in}} \cdot f_{\text{sw}}} \quad (27)$$

8.2.2.6 Slow Start Capacitor Selection

The slow start capacitor determines the minimum amount of time it takes for the output voltage to reach its nominal programmed value during power up. This is useful if a load requires a controlled voltage slew rate. This is also used if the output capacitance is very large and would require large amounts of current to quickly charge the capacitor to the output voltage level. The large currents necessary to charge the capacitor may make the TPS54623 reach the current limit or excessive current draw from the input power supply may cause the input voltage rail to sag. Limiting the output voltage slew rate solves both of these problems. The soft start capacitor value can be calculated using Equation 28. For the example circuit, the soft start time is not too critical since the output capacitor value is 100 μF which does not require much current to charge to 3.3 V. The example circuit has the soft start time set to an arbitrary value of 6 ms which requires a 22 nF capacitor. In TPS54623, I_{ss} is 2.3 μA and V_{ref} is 0.6 V.

$$C_6(\text{nF}) = \frac{T_{\text{ss}}(\text{ms}) \cdot I_{\text{ss}}(\mu\text{A})}{V_{\text{ref}}(\text{V})} \quad (28)$$

8.2.2.7 Bootstrap Capacitor Selection

A 0.1- μF ceramic capacitor must be connected between the BOOT to PH pin for proper operation. It is recommended to use a ceramic capacitor with X5R or better grade dielectric. The capacitor should have 10 V or higher voltage rating.

8.2.2.8 Under Voltage Lockout Set Point

The Undervoltage Lockout (UVLO) can be adjusted using the external voltage divider network of R3 and R4. R3 is connected between VIN and the EN pin of the TPS54623 and R4 is connected between EN and GND. The UVLO has two thresholds, one for power up when the input voltage is rising and one for power down or brown outs when the input voltage is falling. For the example design, the supply should turn on and start switching once the input voltage increases above 6.528 V (UVLO start or enable). After the regulator starts switching, it should continue to do so until the input voltage falls below 6.190 V (UVLO stop or disable). Equation 2 and Equation 3 can be used to calculate the values for the upper and lower resistor values. For the stop voltages specified the nearest standard resistor value for R3 is 35.7 kΩ and for R4 is 8.06 kΩ.

8.2.2.9 Output Voltage Feedback Resistor Selection

The resistor divider network R5 and R6 is used to set the output voltage. For the example design, 10 kΩ was selected for R5. Using Equation 29, R6 is calculated as 2.22 kΩ. The nearest standard 1% resistor is 2.21 kΩ.

$$R6 = \frac{R5 \cdot V_{ref}}{V_o - V_{ref}} \quad (29)$$

8.2.2.9.1 Minimum Output Voltage

Due to the internal design of the TPS54623, there is a minimum output voltage limit for any given input voltage. The output voltage can never be lower than the internal voltage reference of 0.6 V. Above 0.6 V, the output voltage may be limited by the minimum controllable on time. The minimum output voltage in this case is given by Equation 30.

$$V_{outmin} = O_{ntimemin} \cdot F_{smax} (V_{inmax} + I_{outmin} (R_{DS2min} - R_{DS1min})) - I_{outmin} (R_L + R_{DS2min})$$

where

- V_{outmin} = minimum achievable output voltage
- $O_{ntimemin}$ = minimum controllable on-time (135 nsec maximum)
- F_{smax} = maximum switching frequency including tolerance
- V_{inmax} = maximum input voltage
- I_{outmin} = minimum load current
- R_{DS1min} = minimum high side MOSFET on resistance (36-32 mΩ typical)
- R_{DS2min} = minimum low side MOSFET on resistance (19 mΩ typical)
- R_L = series resistance of output inductor

8.2.2.10 Compensation Component Selection

There are several industry techniques used to compensate DC/DC regulators. The method presented here is easy to calculate and yields high phase margins. For most conditions, the regulator has a phase margin between 60 and 90 degrees. The method presented here ignores the effects of the slope compensation that is internal to the TPS54623. Since the slope compensation is ignored, the actual crossover frequency is usually lower than the cross over frequency used in the calculations.

First, the modulator pole, f_{pmod} , and the esr zero, f_{zmod} must be calculated using Equation 31 and Equation 32. For C_{out} , use a derated value of 75 μF. use Equation 33 and Equation 34 to estimate a starting point for the closed loop crossover frequency f_{co} . Then the required compensation components may be derived. For this design example, f_{pmod} is 3.86 kHz and f_{zmod} is 707.4 kHz. Equation 33 is the geometric mean of the modulator pole and the esr zero and Equation 34 is the geometric mean of the modulator pole and one half the switching frequency. Use a frequency near the lower of these two values as the intended crossover frequency f_{co} . In this case Equation 33 yields 52.2 kHz and Equation 34 yields 30.4 kHz. The lower value is 30.4 kHz. A slightly higher frequency of 30 kHz is chosen as the intended crossover frequency.

$$f_{pmod} = \frac{I_{out}}{2 \cdot \pi \cdot V_{out} \cdot C_{out}} \quad (31)$$

$$f_{zmod} = \frac{1}{2 \cdot \pi \cdot RESR \cdot C_{out}} \quad (32)$$

$$f_{co} = \sqrt{f_{pmod} \cdot f_{zmod}} \quad (33)$$

$$f_{co} = \sqrt{f_{pmod} \cdot \frac{f_{sw}}{2}} \tag{34}$$

Now the compensation components can be calculated. First calculate the value for R2 which sets the gain of the compensated network at the crossover frequency. Use Equation 35 to determine the value of R2.

$$R4 = \frac{2\pi \cdot f_c \cdot V_{out} \cdot C_{out}}{g_{m_{ea}} \cdot V_{ref} \cdot g_{m_{ps}}} \tag{35}$$

Next calculate the value of C3. Together with R2, C3 places a compensation zero at the modulator pole frequency. Equation 36 to determine the value of C3.

$$C4 = \frac{V_{out} \cdot C_{out}}{I_{out} \cdot R4} \tag{36}$$

Using Equation 35 and Equation 36 the standard values for R4 and C4 are 3.74 kΩ and 0.01 μF.

An additional high frequency pole can be used if necessary by adding a capacitor in parallel with the series combination of R4 and C4. The pole frequency can be placed at the ESR zero frequency of the output capacitor as given by Equation 12. Use Equation 37 to calculate the required capacitor value for C5.

$$C5 = \frac{RESR \cdot C_{out}}{R4} \tag{37}$$

8.2.3 Application Curves

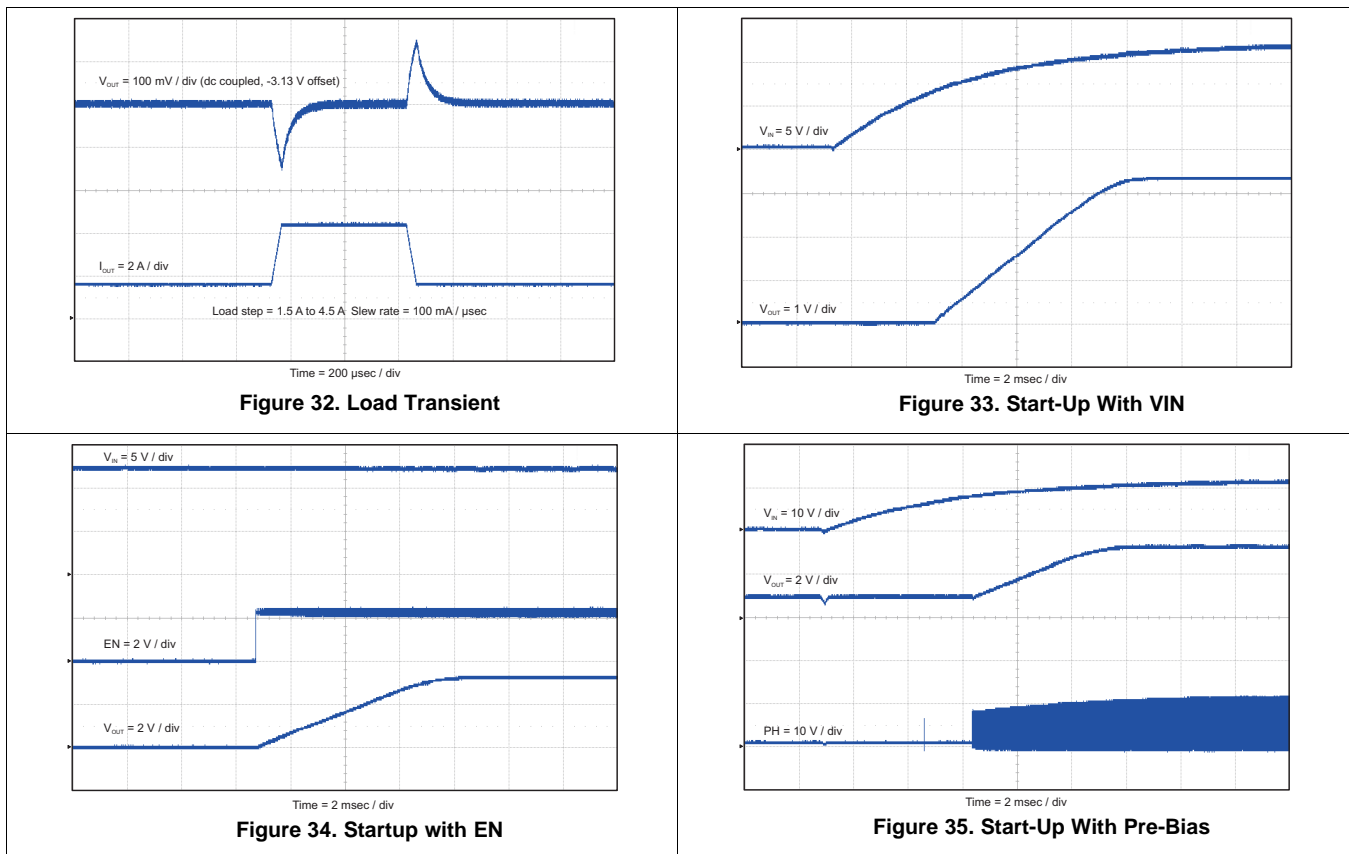

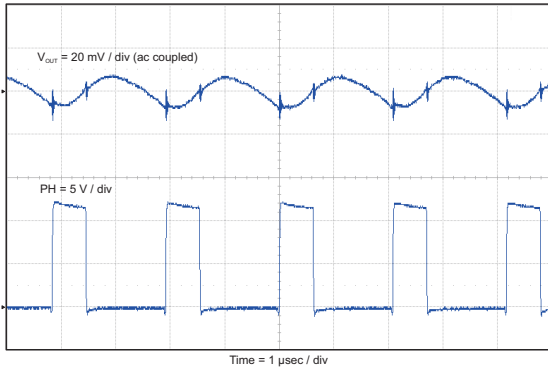

Figure 36. Output Voltage Ripple With Full Load

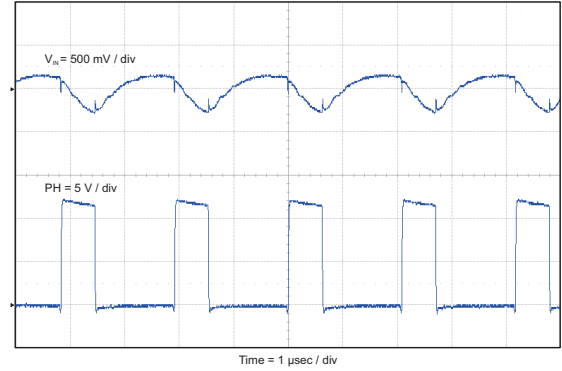

Figure 37. Input Voltage Ripple with Full Load

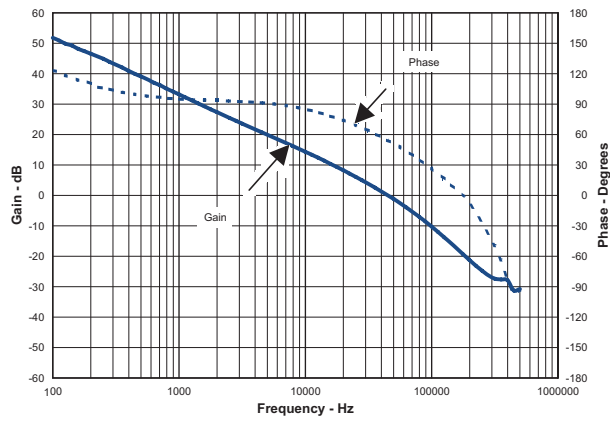

Figure 38. Closed Loop Response

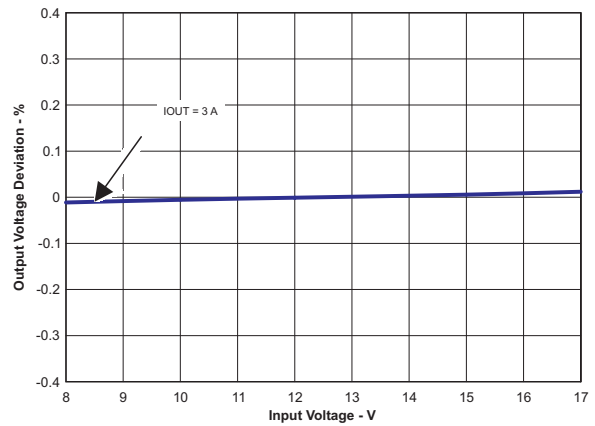

Figure 39. Line Regulation

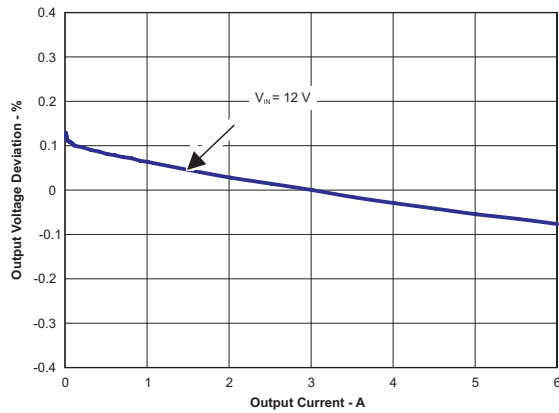

Figure 40. Load Regulation

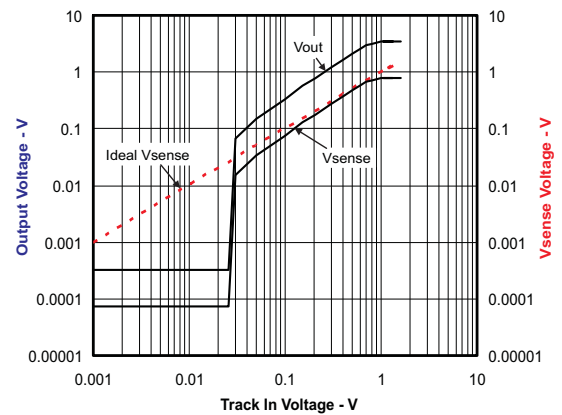

Figure 41. Tracking Performance

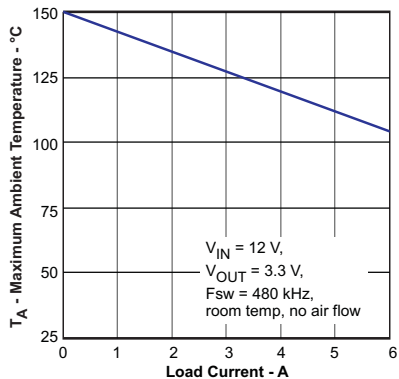

Figure 42. Maximum Ambient Temperature vs Load Current

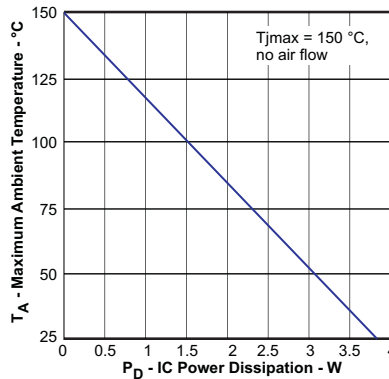

Figure 43. Maximum Ambient Temperature vs IC Power Dissipation

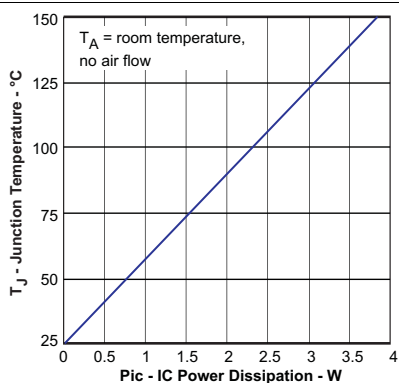

Figure 44. Junction Temperature vs IC Power Dissipation

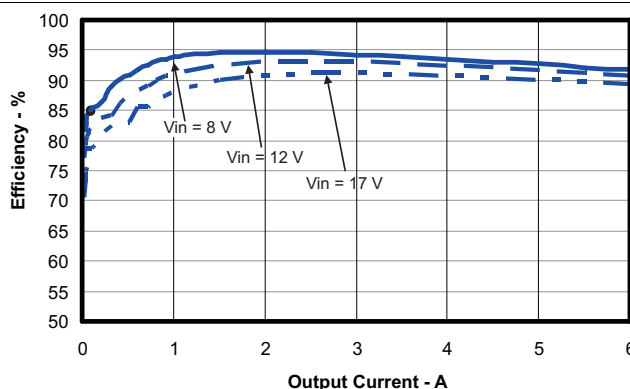

Figure 45. Efficiency vs Load Current

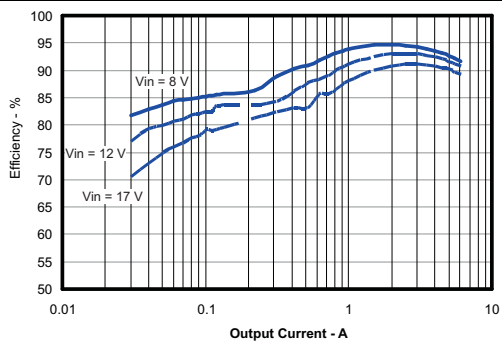

Figure 46. Efficiency vs Output Current

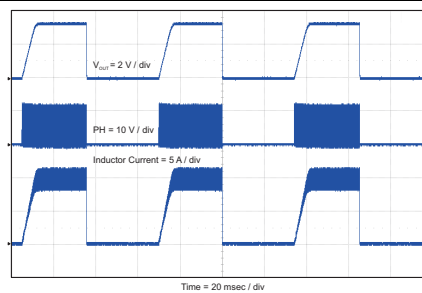

Figure 47. TPS54623 Hiccup Mode Current Limit

9 Power Supply Recommendations

The device is designed to operate from an input-voltage supply range between 4.5 V and 17 V when the VIN and PVIN pins are connected to the same voltage source. This input supply should be well regulated. If the input supply is located more than a few inches from the converter, additional bulk capacitance may be required in addition to the ceramic bypass capacitors. An electrolytic capacitor with a value of 100 μ F is a typical choice.

TPS54623 can be operated with independent voltage sources for the VIN and PVIN inputs. The voltage range for the VIN pin is 4.5 to 17 V. The voltage range for PVIN is 1.7 V to 17 V. Both of these input supplies should be well regulated. If the input supply is located more than a few inches from the converter, additional bulk capacitance may be required in addition to the ceramic bypass capacitors for PVIN.

10 Layout

10.1 Layout Guidelines

Layout is a critical portion of good power supply design. See [Figure 48](#) for a PCB layout example. The top layer contains the main power traces for VIN, VOUT, and VPHASE. Also on the top layer are connections for the remaining pins of the TPS54623 and a large top side area filled with ground. The top layer ground area should be connected to the internal ground layer(s) using vias at the input bypass capacitor, the output filter capacitor and directly under the TPS54623 device to provide a thermal path from the exposed thermal pad land to ground. The GND pin should be tied directly to the power pad under the IC and the power pad. For operation at full rated load, the top side ground area together with the internal ground plane, must provide adequate heat dissipating area. There are several signals paths that conduct fast changing currents or voltages that can interact with stray inductance or parasitic capacitance to generate noise or degrade the power supplies performance. To help eliminate these problems, the PVIN pin must be bypassed to ground with a low ESR ceramic bypass capacitor with X5R or X7R dielectric. Care should be taken to minimize the loop area formed by the bypass capacitor connections, the PVIN pins, and the ground connections. The VIN pin must also be bypassed to ground using a low ESR ceramic capacitor with X5R or X7R dielectric. Make sure to connect this capacitor to the quiet analog ground trace rather than the power ground trace of the PVIN bypass capacitor. Since the PH connection is the switching node, the output inductor should be located close to the PH pins, and the area of the PCB conductor minimized to prevent excessive capacitive coupling. The output filter capacitor ground should use the same power ground trace as the PVIN input bypass capacitor. Try to minimize this conductor length while maintaining adequate width. The small signal components should be grounded to the analog ground path as shown. The RT/CLK pin is sensitive to noise so the RT resistor should be located as close as possible to the IC and routed with minimal lengths of trace. The additional external components can be placed approximately as shown. It may be possible to obtain acceptable performance with alternate PCB layouts, however this layout has been shown to produce good results and is meant as a guideline.

Land pattern and stencil information is provided in the data sheet addendum. The dimension and outline information is for the standard RHL (S-PVQFN-N14) package. There may be slight differences between the provided data and actual lead frame used on the TPS54623RHL package.

10.1.1 Estimated Circuit Area

The estimated printed circuit board area for the components used in the design of [Figure 31](#) is 0.58 in² (374 mm²). This area does not include test points or connectors.

10.2 Layout Examples

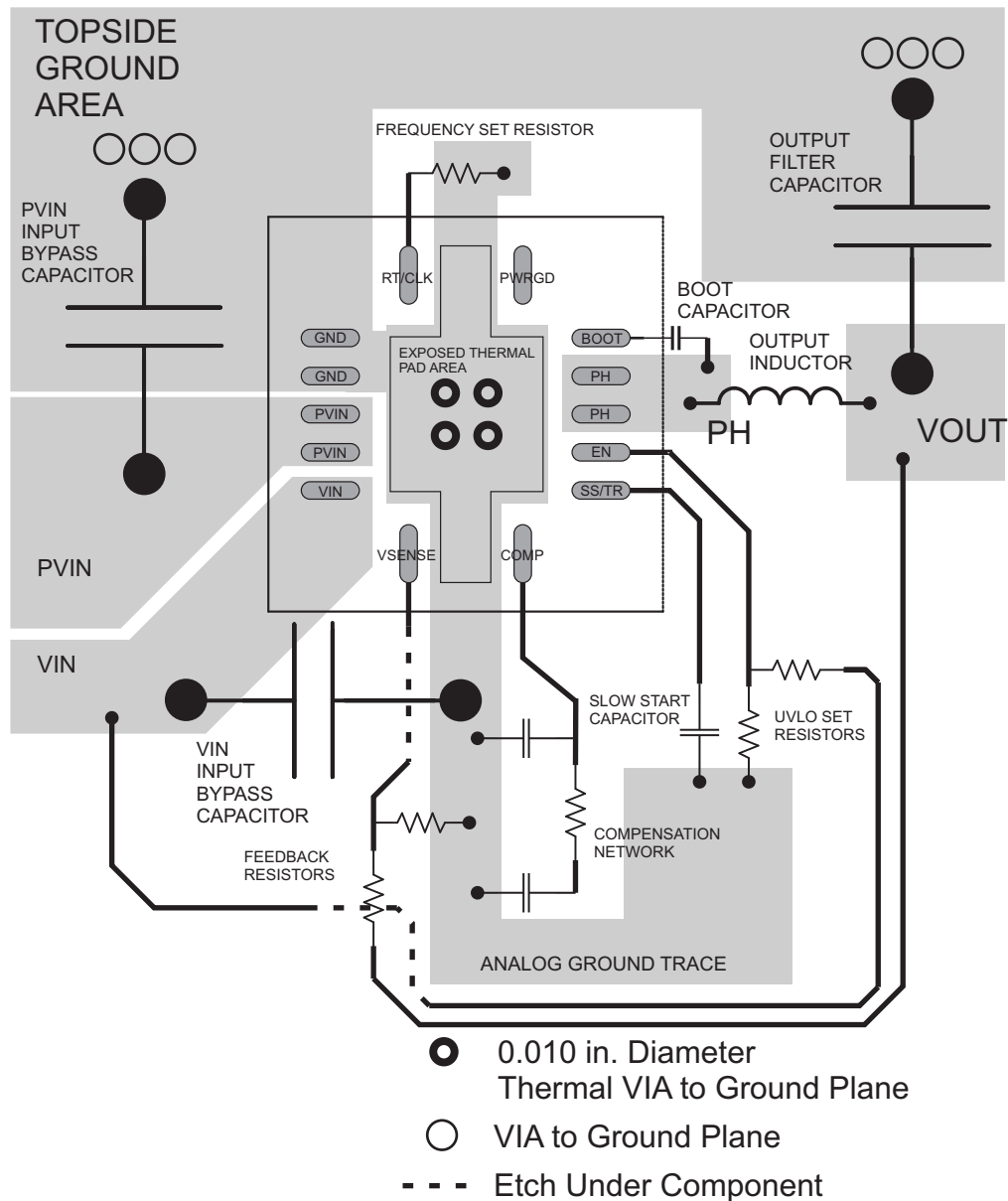

Figure 48. PCB Layout

Layout Examples (continued)

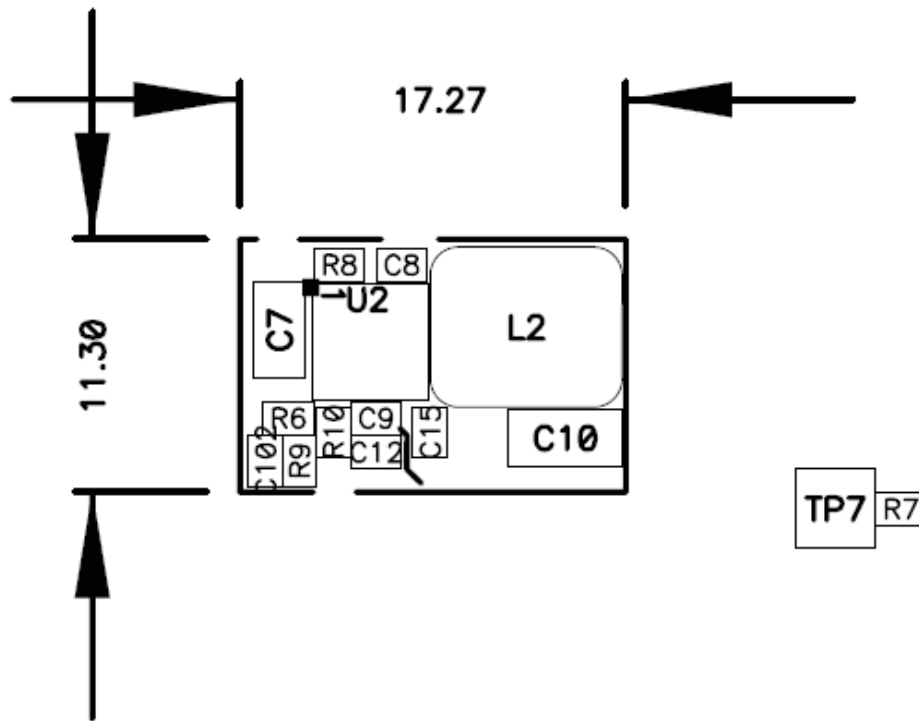

Figure 49. Ultra-Small PCB Layout Using TPS54623 (PMP4854-2)

11 Device and Documentation Support

11.1 Device Support

11.1.1 Third-Party Products Disclaimer

TI'S PUBLICATION OF INFORMATION REGARDING THIRD-PARTY PRODUCTS OR SERVICES DOES NOT CONSTITUTE AN ENDORSEMENT REGARDING THE SUITABILITY OF SUCH PRODUCTS OR SERVICES OR A WARRANTY, REPRESENTATION OR ENDORSEMENT OF SUCH PRODUCTS OR SERVICES, EITHER ALONE OR IN COMBINATION WITH ANY TI PRODUCT OR SERVICE.

11.1.2 Development Support

For SWIFT™ Documentation, visit <http://www.ti.com/swift>

11.1.3 Custom Design With WEBENCH® Tools

[Click here](#) to create a custom design using the TPS54623 device with the WEBENCH® Power Designer.

1. Start by entering the input voltage (V_{IN}), output voltage (V_{OUT}), and output current (I_{OUT}) requirements.
2. Optimize the design for key parameters such as efficiency, footprint, and cost using the optimizer dial.
3. Compare the generated design with other possible solutions from Texas Instruments.

The WEBENCH Power Designer provides a customized schematic along with a list of materials with real-time pricing and component availability.

In most cases, these actions are available:

- Run electrical simulations to see important waveforms and circuit performance
- Run thermal simulations to understand board thermal performance
- Export customized schematic and layout into popular CAD formats
- Print PDF reports for the design, and share the design with colleagues

Get more information about WEBENCH tools at www.ti.com/WEBENCH.

11.2 Documentation Support

11.2.1 Related Documentation

For related documentation see the following:

- [Designing Type III Compensation for Current Mode Step-Down Converters](#)
- Design Calculator, [SLVC219](#)

11.3 Receiving Notification of Documentation Updates

To receive notification of documentation updates, navigate to the device product folder on ti.com. In the upper right corner, click on *Alert me* to register and receive a weekly digest of any product information that has changed. For change details, review the revision history included in any revised document.

11.4 Community Resources

The following links connect to TI community resources. Linked contents are provided "AS IS" by the respective contributors. They do not constitute TI specifications and do not necessarily reflect TI's views; see TI's [Terms of Use](#).

TI E2E™ Online Community *TI's Engineer-to-Engineer (E2E) Community*. Created to foster collaboration among engineers. At e2e.ti.com, you can ask questions, share knowledge, explore ideas and help solve problems with fellow engineers.

Design Support *TI's Design Support* Quickly find helpful E2E forums along with design support tools and contact information for technical support.

11.5 Trademarks

E2E is a trademark of Texas Instruments.

11.5 Trademarks (continued)

WEBENCH is a registered trademark of Texas Instruments.
All other trademarks are the property of their respective owners.

11.6 Electrostatic Discharge Caution



This integrated circuit can be damaged by ESD. Texas Instruments recommends that all integrated circuits be handled with appropriate precautions. Failure to observe proper handling and installation procedures can cause damage.

ESD damage can range from subtle performance degradation to complete device failure. Precision integrated circuits may be more susceptible to damage because very small parametric changes could cause the device not to meet its published specifications.

11.7 Glossary

[SLYZ022](#) — *TI Glossary*.

This glossary lists and explains terms, acronyms, and definitions.

12 Mechanical, Packaging, and Orderable Information

The following pages include mechanical, packaging, and orderable information. This information is the most current data available for the designated devices. This data is subject to change without notice and revision of this document. For browser-based versions of this data sheet, refer to the left-hand navigation.

PACKAGING INFORMATION

Orderable Device	Status (1)	Package Type	Package Drawing	Pins	Package Qty	Eco Plan (2)	Lead/Ball Finish (6)	MSL Peak Temp (3)	Op Temp (°C)	Device Marking (4/5)	Samples
TPS54623RHLR	ACTIVE	VQFN	RHL	14	3000	Green (RoHS & no Sb/Br)	CU NIPDAU	Level-2-260C-1 YEAR	-40 to 150	54623	Samples
TPS54623RHLT	ACTIVE	VQFN	RHL	14	250	Green (RoHS & no Sb/Br)	CU NIPDAU	Level-2-260C-1 YEAR	-40 to 150	54623	Samples

(1) The marketing status values are defined as follows:

ACTIVE: Product device recommended for new designs.

LIFEBUY: TI has announced that the device will be discontinued, and a lifetime-buy period is in effect.

NRND: Not recommended for new designs. Device is in production to support existing customers, but TI does not recommend using this part in a new design.

PREVIEW: Device has been announced but is not in production. Samples may or may not be available.

OBSOLETE: TI has discontinued the production of the device.

(2) **RoHS:** TI defines "RoHS" to mean semiconductor products that are compliant with the current EU RoHS requirements for all 10 RoHS substances, including the requirement that RoHS substance do not exceed 0.1% by weight in homogeneous materials. Where designed to be soldered at high temperatures, "RoHS" products are suitable for use in specified lead-free processes. TI may reference these types of products as "Pb-Free".

RoHS Exempt: TI defines "RoHS Exempt" to mean products that contain lead but are compliant with EU RoHS pursuant to a specific EU RoHS exemption.

Green: TI defines "Green" to mean the content of Chlorine (Cl) and Bromine (Br) based flame retardants meet JS709B low halogen requirements of <=1000ppm threshold. Antimony trioxide based flame retardants must also meet the <=1000ppm threshold requirement.

(3) MSL, Peak Temp. - The Moisture Sensitivity Level rating according to the JEDEC industry standard classifications, and peak solder temperature.

(4) There may be additional marking, which relates to the logo, the lot trace code information, or the environmental category on the device.

(5) Multiple Device Markings will be inside parentheses. Only one Device Marking contained in parentheses and separated by a "~" will appear on a device. If a line is indented then it is a continuation of the previous line and the two combined represent the entire Device Marking for that device.

(6) Lead/Ball Finish - Orderable Devices may have multiple material finish options. Finish options are separated by a vertical ruled line. Lead/Ball Finish values may wrap to two lines if the finish value exceeds the maximum column width.

Important Information and Disclaimer:The information provided on this page represents TI's knowledge and belief as of the date that it is provided. TI bases its knowledge and belief on information provided by third parties, and makes no representation or warranty as to the accuracy of such information. Efforts are underway to better integrate information from third parties. TI has taken and continues to take reasonable steps to provide representative and accurate information but may not have conducted destructive testing or chemical analysis on incoming materials and chemicals. TI and TI suppliers consider certain information to be proprietary, and thus CAS numbers and other limited information may not be available for release.

In no event shall TI's liability arising out of such information exceed the total purchase price of the TI part(s) at issue in this document sold by TI to Customer on an annual basis.

TAPE AND REEL INFORMATION



QUADRANT ASSIGNMENTS FOR PIN 1 ORIENTATION IN TAPE



*All dimensions are nominal

Device	Package Type	Package Drawing	Pins	SPQ	Reel Diameter (mm)	Reel Width W1 (mm)	A0 (mm)	B0 (mm)	K0 (mm)	P1 (mm)	W (mm)	Pin1 Quadrant
TPS54623RHLR	VQFN	RHL	14	3000	330.0	12.4	3.75	3.75	1.15	8.0	12.0	Q2
TPS54623RHLL	VQFN	RHL	14	250	180.0	12.4	3.75	3.75	1.15	8.0	12.0	Q2

TAPE AND REEL BOX DIMENSIONS

*All dimensions are nominal

Device	Package Type	Package Drawing	Pins	SPQ	Length (mm)	Width (mm)	Height (mm)
TPS54623RHRLR	VQFN	RHL	14	3000	367.0	367.0	35.0
TPS54623RHILT	VQFN	RHL	14	250	210.0	185.0	35.0

RHL (S-PVQFN-N14)

PLASTIC QUAD FLATPACK NO-LEAD

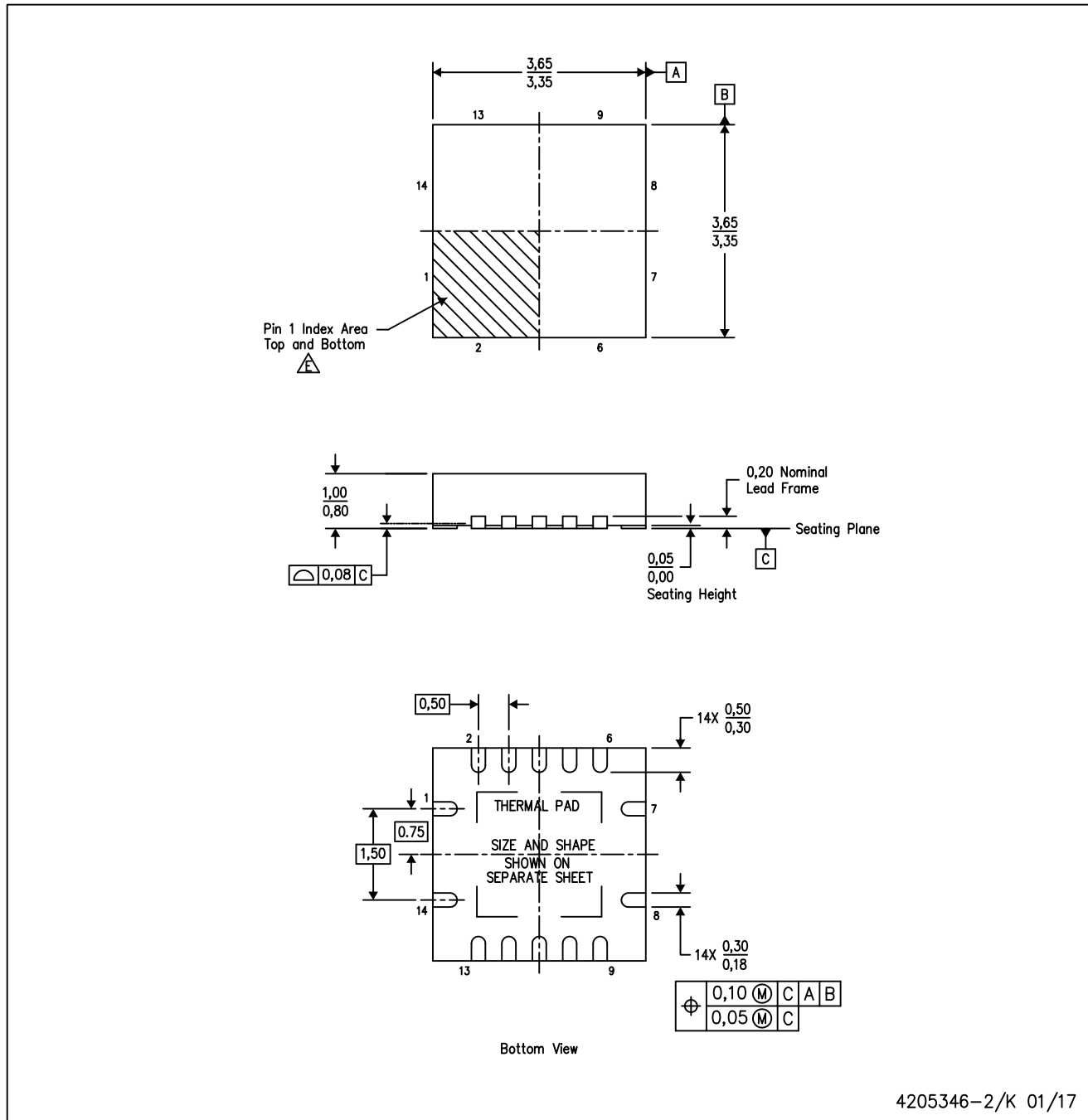

- NOTES:
- A. All linear dimensions are in millimeters. Dimensioning and tolerancing per ASME Y14.5M-1994.
 - B. This drawing is subject to change without notice.
 - C. QFN (Quad Flatpack No-Lead) Package configuration.
 - D. The package thermal pad must be soldered to the board for thermal and mechanical performance.
 - E. See the additional figure in the Product Data Sheet for details regarding the exposed thermal pad features and dimensions.

THERMAL PAD MECHANICAL DATA

RHL (S-PVQFN-N14)

PLASTIC QUAD FLATPACK NO-LEAD

THERMAL INFORMATION

This package incorporates an exposed thermal pad that is designed to be attached directly to an external heatsink. The thermal pad must be soldered directly to the printed circuit board (PCB). After soldering, the PCB can be used as a heatsink. In addition, through the use of thermal vias, the thermal pad can be attached directly to the appropriate copper plane shown in the electrical schematic for the device, or alternatively, can be attached to a special heatsink structure designed into the PCB. This design optimizes the heat transfer from the integrated circuit (IC).

For information on the Quad Flatpack No-Lead (QFN) package and its advantages, refer to Application Report, QFN/SON PCB Attachment, Texas Instruments Literature No. SLUA271. This document is available at www.ti.com.

The exposed thermal pad dimensions for this package are shown in the following illustration.

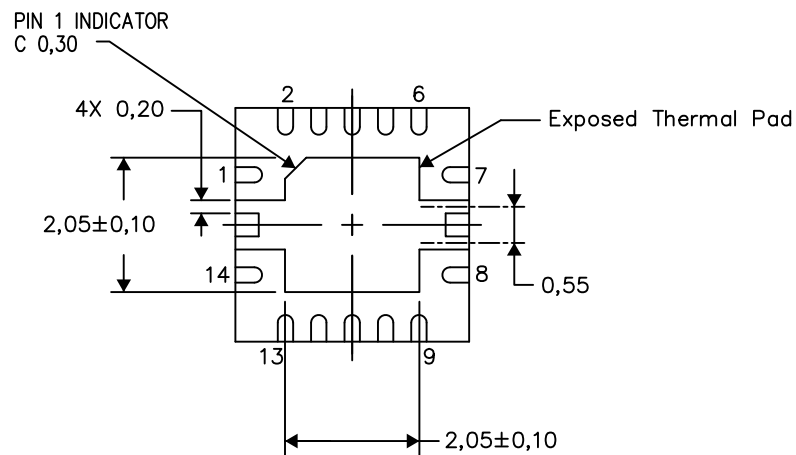

Bottom View

Exposed Thermal Pad Dimensions

4206363-2/N 07/14

NOTE: All linear dimensions are in millimeters

IMPORTANT NOTICE

Texas Instruments Incorporated (TI) reserves the right to make corrections, enhancements, improvements and other changes to its semiconductor products and services per JESD46, latest issue, and to discontinue any product or service per JESD48, latest issue. Buyers should obtain the latest relevant information before placing orders and should verify that such information is current and complete.

TI's published terms of sale for semiconductor products (<http://www.ti.com/sc/docs/stdterms.htm>) apply to the sale of packaged integrated circuit products that TI has qualified and released to market. Additional terms may apply to the use or sale of other types of TI products and services.

Reproduction of significant portions of TI information in TI data sheets is permissible only if reproduction is without alteration and is accompanied by all associated warranties, conditions, limitations, and notices. TI is not responsible or liable for such reproduced documentation. Information of third parties may be subject to additional restrictions. Resale of TI products or services with statements different from or beyond the parameters stated by TI for that product or service voids all express and any implied warranties for the associated TI product or service and is an unfair and deceptive business practice. TI is not responsible or liable for any such statements.

Buyers and others who are developing systems that incorporate TI products (collectively, "Designers") understand and agree that Designers remain responsible for using their independent analysis, evaluation and judgment in designing their applications and that Designers have full and exclusive responsibility to assure the safety of Designers' applications and compliance of their applications (and of all TI products used in or for Designers' applications) with all applicable regulations, laws and other applicable requirements. Designer represents that, with respect to their applications, Designer has all the necessary expertise to create and implement safeguards that (1) anticipate dangerous consequences of failures, (2) monitor failures and their consequences, and (3) lessen the likelihood of failures that might cause harm and take appropriate actions. Designer agrees that prior to using or distributing any applications that include TI products, Designer will thoroughly test such applications and the functionality of such TI products as used in such applications.

TI's provision of technical, application or other design advice, quality characterization, reliability data or other services or information, including, but not limited to, reference designs and materials relating to evaluation modules, (collectively, "TI Resources") are intended to assist designers who are developing applications that incorporate TI products; by downloading, accessing or using TI Resources in any way, Designer (individually or, if Designer is acting on behalf of a company, Designer's company) agrees to use any particular TI Resource solely for this purpose and subject to the terms of this Notice.

TI's provision of TI Resources does not expand or otherwise alter TI's applicable published warranties or warranty disclaimers for TI products, and no additional obligations or liabilities arise from TI providing such TI Resources. TI reserves the right to make corrections, enhancements, improvements and other changes to its TI Resources. TI has not conducted any testing other than that specifically described in the published documentation for a particular TI Resource.

Designer is authorized to use, copy and modify any individual TI Resource only in connection with the development of applications that include the TI product(s) identified in such TI Resource. NO OTHER LICENSE, EXPRESS OR IMPLIED, BY ESTOPPEL OR OTHERWISE TO ANY OTHER TI INTELLECTUAL PROPERTY RIGHT, AND NO LICENSE TO ANY TECHNOLOGY OR INTELLECTUAL PROPERTY RIGHT OF TI OR ANY THIRD PARTY IS GRANTED HEREIN, including but not limited to any patent right, copyright, mask work right, or other intellectual property right relating to any combination, machine, or process in which TI products or services are used. Information regarding or referencing third-party products or services does not constitute a license to use such products or services, or a warranty or endorsement thereof. Use of TI Resources may require a license from a third party under the patents or other intellectual property of the third party, or a license from TI under the patents or other intellectual property of TI.

TI RESOURCES ARE PROVIDED "AS IS" AND WITH ALL FAULTS. TI DISCLAIMS ALL OTHER WARRANTIES OR REPRESENTATIONS, EXPRESS OR IMPLIED, REGARDING RESOURCES OR USE THEREOF, INCLUDING BUT NOT LIMITED TO ACCURACY OR COMPLETENESS, TITLE, ANY EPIDEMIC FAILURE WARRANTY AND ANY IMPLIED WARRANTIES OF MERCHANTABILITY, FITNESS FOR A PARTICULAR PURPOSE, AND NON-INFRINGEMENT OF ANY THIRD PARTY INTELLECTUAL PROPERTY RIGHTS. TI SHALL NOT BE LIABLE FOR AND SHALL NOT DEFEND OR INDEMNIFY DESIGNER AGAINST ANY CLAIM, INCLUDING BUT NOT LIMITED TO ANY INFRINGEMENT CLAIM THAT RELATES TO OR IS BASED ON ANY COMBINATION OF PRODUCTS EVEN IF DESCRIBED IN TI RESOURCES OR OTHERWISE. IN NO EVENT SHALL TI BE LIABLE FOR ANY ACTUAL, DIRECT, SPECIAL, COLLATERAL, INDIRECT, PUNITIVE, INCIDENTAL, CONSEQUENTIAL OR EXEMPLARY DAMAGES IN CONNECTION WITH OR ARISING OUT OF TI RESOURCES OR USE THEREOF, AND REGARDLESS OF WHETHER TI HAS BEEN ADVISED OF THE POSSIBILITY OF SUCH DAMAGES.

Unless TI has explicitly designated an individual product as meeting the requirements of a particular industry standard (e.g., ISO/TS 16949 and ISO 26262), TI is not responsible for any failure to meet such industry standard requirements.

Where TI specifically promotes products as facilitating functional safety or as compliant with industry functional safety standards, such products are intended to help enable customers to design and create their own applications that meet applicable functional safety standards and requirements. Using products in an application does not by itself establish any safety features in the application. Designers must ensure compliance with safety-related requirements and standards applicable to their applications. Designer may not use any TI products in life-critical medical equipment unless authorized officers of the parties have executed a special contract specifically governing such use. Life-critical medical equipment is medical equipment where failure of such equipment would cause serious bodily injury or death (e.g., life support, pacemakers, defibrillators, heart pumps, neurostimulators, and implantables). Such equipment includes, without limitation, all medical devices identified by the U.S. Food and Drug Administration as Class III devices and equivalent classifications outside the U.S.

TI may expressly designate certain products as completing a particular qualification (e.g., Q100, Military Grade, or Enhanced Product). Designers agree that it has the necessary expertise to select the product with the appropriate qualification designation for their applications and that proper product selection is at Designers' own risk. Designers are solely responsible for compliance with all legal and regulatory requirements in connection with such selection.

Designer will fully indemnify TI and its representatives against any damages, costs, losses, and/or liabilities arising out of Designer's non-compliance with the terms and provisions of this Notice.

Looking for pricing, stock, or lifecycle information?

Click below to explore more details on WIN SOURCE:

 [View TPS54623RHLT on WIN SOURCE](#)

 [Texas Instruments](#) Information

Optimize Your Supply Chain with WIN SOURCE Solutions

-  Global Sourcing Solution
-  Obsolete Management
-  Cost Control Management
-  Shortage Management
-  Alternative Solution
-  Excess Inventory Management