



**THE DATASHEET OF  
AD1839AS**



### FEATURES

- 5 V stereo audio system with 3.3 V tolerant digital interface**
- Supports up to 96 kHz sample rates**
- 192 kHz sample rate available on 1 DAC**
- Supports 16-/20-/24-bit word lengths**
- Multibit  $\Sigma$ - $\Delta$  modulators with perfect differential linearity restoration for reduced idle tones and noise floor**
- Data-directed scrambling DACs—least sensitive to jitter**
- Single-ended output**
- ADCs: -95 dB THD + N, 105 dB SNR and dynamic range**
- DACs: -92 dB THD + N, 108 dB SNR and dynamic range**
- On-chip volume controls per channel with 1024-step linear scale**
- DAC and ADC software controllable clickless mutes**
- Digital de-emphasis processing**
- Supports  $256 \times f_s$ ,  $512 \times f_s$ , and  $768 \times f_s$  master mode clocks**
- Power-down mode and soft power-down mode**
- Flexible serial data port with right-justified, left-justified, I<sup>2</sup>S compatible, and DSP serial modes**
- TDM interface mode supports 8-in/8-out operation using a single SHARC<sup>®</sup> SPORT**
- 52-lead MQFP plastic package**

### APPLICATIONS

- DVD video and audio players**
- Home theater systems**
- Automotive audio systems**
- Audio/visual receivers**
- Digital audio effects process**

### GENERAL DESCRIPTION

The AD1839A is a high performance single-chip codec that features three stereo DACs and one stereo ADC. Each DAC comprises a high performance digital interpolation filter, a multibit  $\Sigma$ - $\Delta$  modulator featuring Analog Devices' patented technology, and a continuous-time voltage-out analog section. Each DAC has independent volume control and clickless mute functions. The ADC comprises two 24-bit conversion channels with multibit  $\Sigma$ - $\Delta$  modulators and decimation filters.

The AD1839A also contains an on-chip reference with a nominal value of 2.25 V.

The AD1839A contains a flexible serial interface that allows glueless connection to a variety of DSP chips, AES/EBU receivers, and sample rate converters. The AD1839A can be configured in left-justified, right-justified, I<sup>2</sup>S, or DSP compatible serial modes. Control of the AD1839A is achieved by means of an SPI<sup>®</sup> compatible serial port. While the AD1839A can be operated from a single 5 V supply, it also features a separate supply pin for its digital interface that allows the device to be interfaced to other devices using 3.3 V power supplies. The AD1839A is available in a 52-lead MQFP package and is specified for the -40°C to +85°C industrial temperature range.

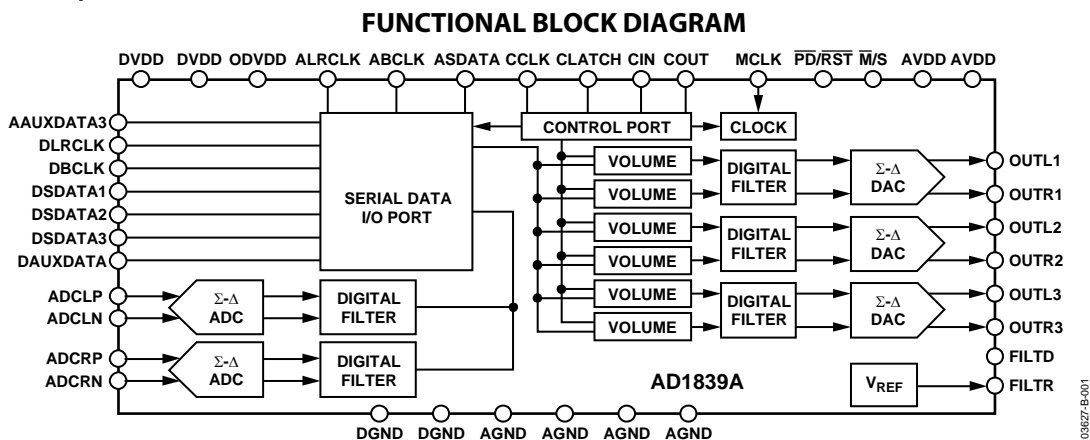

Figure 1.

### Rev. B

Information furnished by Analog Devices is believed to be accurate and reliable. However, no responsibility is assumed by Analog Devices for its use, nor for any infringements of patents or other rights of third parties that may result from its use. Specifications subject to change without notice. No license is granted by implication or otherwise under any patent or patent rights of Analog Devices. Trademarks and registered trademarks are the property of their respective owners.

## TABLE OF CONTENTS

Specifications.....	3	DAC and ADC Coding.....	12
Test Conditions.....	3	AD1839A Clocking Scheme .....	12
Timing Specifications.....	5	RESET and Power-Down .....	13
Absolute Maximum Ratings.....	7	Power Supply and Voltage Reference.....	13
Temperature Range .....	7	Serial Control Port .....	13
ESD Caution.....	7	Serial Data Ports—Data Format.....	14
Pin Configuration and Function Descriptions.....	8	Packed Modes .....	14
Typical Performance Characteristics .....	9	Auxiliary Time Division Multiplexing (TDM) Mode .....	14
Terminology .....	11	Control/Status Registers .....	19
Functional Overview.....	12	Cascade Mode.....	22
ADCs.....	12	Outline Dimensions .....	24
DACs .....	12	Ordering Guide .....	24

## REVISION HISTORY

### 5/04—Data Sheet Changed from Rev. A to Rev. B

Updated FormatUniversal  
Changes to Data Sheet Title1

### 2/04—Data Sheet Changed from Rev. 0 to Rev. A

Changes to Ordering Guide .....	6
Deleted Clock Signals Section .....	11
Added AD1835A Clocking Scheme Section.....	11
Added Table II and Table III and renumbered following tables	11
Changes to Auxiliary (TDM Mode) Section.....	13
Changes to Figure 5.....	14
Changes to Figure 6.....	14
Added Figures 7a and 8a.....	15
Renamed Figure 7 and Figure 8 to Figure 7b and Figure 8b .....	15
Changes to Figure 9.....	15
Changes to Table VIII .....	21
Updated Outline Dimensions .....	24

## SPECIFICATIONS

### TEST CONDITIONS

Supply Voltages	5.0 V (AVDD, DVDD)
Ambient Temperature	25°C
Input Clock	12.288 MHz (256 × f <sub>s</sub> mode)
DAC Input Signal	1.0078125 kHz, 0 dBFS
ADC Input Signal	1.0078125 kHz, -1 dBFS
Input Sample Rate (f <sub>s</sub> )	48 kHz
Measurement Bandwidth	0 Hz to 20 kHz
Word Width	24 bits
Load Capacitance	100 pF
Load Impedance	47 kΩ

Performance of all channels is identical (except for the Interchannel Gain Mismatch and Interchannel Phase Deviation specifications).

**Table 1.**

Parameter	Min	Typ	Max	Unit
<b>ANALOG-TO-DIGITAL CONVERTERS</b>				
ADC Resolution		24		Bits
Dynamic Range (20 Hz to 20 kHz, -60 dB Input)				
No Filter		103		dB
A-Weighted (48 kHz and 96 kHz)	100	105		dB
Total Harmonic Distortion + Noise (THD + N)				
48 kHz		-95	-88.5	dB
96 kHz		-95	-87.5	dB
Interchannel Isolation		100		dB
Interchannel Gain Mismatch		0.025		dB
Analog Inputs				
Differential Input Range (±Full Scale)	-2.828		+2.828	V
Common-Mode Input Voltage		2.25		V
Input Impedance		4		kΩ
Input Capacitance		15		pF
V <sub>REF</sub>		2.25		V
DC Accuracy				
Gain Error		±5		%
Gain Drift		35		ppm/°C
<b>DIGITAL-TO-ANALOG CONVERTERS</b>				
DAC Resolution		24		Bits
Dynamic Range (20 Hz to 20 kHz, -60 dBFS Input)				
No Filter	103	105		dB
A-Weighted Filter (48 kHz and 96 kHz)	105	108		dB
Total Harmonic Distortion + Noise (48 kHz and 96 kHz)		-92	-90	dB
Interchannel Isolation		110		dB
DC Accuracy				
Gain Error		±4		%
Interchannel Gain Mismatch		0.025		dB
Gain Drift		200		ppm/°C
Interchannel Phase Deviation		±0.1		Degrees
Volume Control Step Size (1023 Linear Steps)		0.098		%
Volume Control Range (Maximum Attenuation)		60		dB
Mute Attenuation		-100		dB
De-emphasis Gain Error		±0.1		dB
Full-Scale Output Voltage at Each Pin (Single-Ended)		1.0 (2.8)		V rms (V p-p)
Output Resistance at Each Pin		180		Ω
Common-Mode Output Voltage		2.25		V

# AD1839A

Parameter	Min	Typ	Max	Unit
<b>ADC DECIMATION FILTER, 48 kHz<sup>1</sup></b>				
Pass Band		21.77		kHz
Pass-Band Ripple		±0.01		dB
Stop Band		26.23		kHz
Stop-Band Attenuation		120		dB
Group Delay		910		µs
<b>ADC DECIMATION FILTER, 96 kHz<sup>1</sup></b>				
Pass Band		43.54		kHz
Pass-Band Ripple		±0.01		dB
Stop Band		52.46		kHz
Stop-Band Attenuation		120		dB
Group Delay		460		µs
<b>DAC INTERPOLATION FILTER, 48 kHz<sup>1</sup></b>				
Pass Band			21.77	kHz
Pass-Band Ripple		±0.01		dB
Stop Band	28			kHz
Stop-Band Attenuation	55			dB
Group Delay		340		µs
<b>DAC INTERPOLATION FILTER, 96 kHz<sup>1</sup></b>				
Pass Band			43.54	kHz
Pass-Band Ripple		±0.01		dB
Stop Band	52			kHz
Stop-Band Attenuation	55			dB
Group Delay		160		µs
<b>DAC INTERPOLATION FILTER, 192 kHz<sup>1</sup></b>				
Pass Band			81.2	kHz
Pass-Band Ripple		±0.06		dB
Stop Band	97			kHz
Stop-Band Attenuation	80			dB
Group Delay		110		µs
<b>DIGITAL I/O</b>				
Input Voltage High	2.4			V
Input Voltage Low			0.8	V
Output Voltage High	ODVDD – 0.4			V
Output Voltage Low			0.4	V
Leakage Current			±10	µA
<b>POWER SUPPLIES</b>				
Supply Voltage (AVDD and DVDD)	4.5	5.0	5.5	V
Supply Voltage (ODVDD)	3.0		DVDD	V
Supply Current I <sub>ANALOG</sub>		84	95	mA
Supply Current I <sub>ANALOG</sub> , Power-Down		55	67	mA
Supply Current I <sub>DIGITAL</sub>		64	74	mA
Supply Current I <sub>DIGITAL</sub> , Power-Down		1	4.5	mA
<b>Dissipation</b>				
Operation, Both Supplies		740		mW
Operation, Analog Supply		420		mW
Operation, Digital Supply		320		mW
Power-Down, Both Supplies		280		mW
<b>Power Supply Rejection Ratio</b>				
1 kHz, 300 mV p-p Signal at Analog Supply Pins		–70		dB
20 kHz, 300 mV p-p Signal at Analog Supply Pins		–75		dB

<sup>1</sup> Guaranteed by design.

## TIMING SPECIFICATIONS

Table 2.

Parameter		Min	Max	Unit	Comments
<b>MASTER CLOCK AND RESET</b>					
t <sub>MH</sub>	MCLK High	15		ns	
t <sub>ML</sub>	MCLK Low	15		ns	
t <sub>PDR</sub>	PD/RST Low	20		ns	
<b>SPI PORT</b>					
t <sub>CCH</sub>	CCLK High	40		ns	
t <sub>CCL</sub>	CCLK Low	40		ns	
t <sub>CCP</sub>	CCLK Period	80		ns	
t <sub>CDS</sub>	CDATA Setup	10		ns	To CCLK rising edge
t <sub>CDH</sub>	CDATA Hold	10		ns	From CCLK rising edge
t <sub>CLS</sub>	CLATCH Setup	10		ns	To CCLK rising edge
t <sub>CLH</sub>	CLATCH Hold	10		ns	From CCLK rising edge
t <sub>COE</sub>	COU Enable		15	ns	From CLATCH falling edge
t <sub>COD</sub>	COU Delay		20	ns	From CCLK falling edge
t <sub>COTS</sub>	COU Three-State		25	ns	From CLATCH rising edge
<b>DAC SERIAL PORT (48 kHz and 96 kHz)</b>					
Normal Mode (Slave)					
t <sub>DBH</sub>	DBCLK High	60		ns	
t <sub>DBL</sub>	DBCLK Low	60		ns	
f <sub>DB</sub>	DBCLK Frequency	64 × f <sub>s</sub>			
t <sub>DLS</sub>	DLRCLK Setup	10		ns	To DBCLK rising edge
t <sub>DLH</sub>	DLRCLK Hold	10		ns	From DBCLK rising edge
t <sub>DDS</sub>	DSDATA Setup	10		ns	To DBCLK rising edge
t <sub>DDH</sub>	DSDATA Hold	10		ns	From DBCLK rising edge
Packed 128/256 Modes (Slave)					
t <sub>DBH</sub>	DBCLK High	15		ns	
t <sub>DBL</sub>	DBCLK Low	15		ns	
f <sub>DB</sub>	DBCLK Frequency	256 × f <sub>s</sub>			
t <sub>DLS</sub>	DLRCLK Setup	10		ns	To DBCLK rising edge
t <sub>DLH</sub>	DLRCLK Hold	10		ns	From DBCLK rising edge
t <sub>DDS</sub>	DSDATA Setup	10		ns	To DBCLK rising edge
t <sub>DDH</sub>	DSDATA Hold	10		ns	From DBCLK rising edge
<b>ADC SERIAL PORT (48 kHz and 96 kHz)</b>					
Normal Mode (Master)					
t <sub>ABD</sub>	ABCLK Delay		25	ns	From MCLK rising edge
t <sub>ALD</sub>	ALRCLK Delay		5	ns	From ABCLK falling edge
t <sub>ABDD</sub>	ASDATA Delay		10	ns	From ABCLK falling edge
Normal Mode (Slave)					
t <sub>ABH</sub>	ABCLK High	60		ns	
t <sub>ABL</sub>	ABCLK Low	60		ns	
f <sub>AB</sub>	ABCLK Frequency	64 × f <sub>s</sub>			
t <sub>ALS</sub>	ALRCLK Setup	5		ns	To ABCLK rising edge
t <sub>ALH</sub>	ALRCLK Hold	15		ns	From ABCLK rising edge
t <sub>ABDD</sub>	ASDATA Delay		15	ns	From ABCLK falling edge
Packed 128/256 Mode (Master)					
t <sub>PABD</sub>	ABCLK Delay		40	ns	From MCLK rising edge
t <sub>PALD</sub>	LRCLK Delay		5	ns	From ABCLK falling edge
t <sub>PABDD</sub>	ASDATA Delay		10	ns	From ABCLK falling edge

# AD1839A

Parameter		Min	Max	Unit	Comments
<b>TDM256 MODE (Master, 48 kHz and 96 kHz)</b>					
$t_{TBD}$	BCLK Delay		40	ns	From MCLK rising edge
$t_{FSD}$	FSTDM Delay		5	ns	From BCLK rising edge
$t_{TABDD}$	ASDATA Delay		10	ns	From BCLK rising edge
$t_{TDDS}$	DSDATA1 Setup	15		ns	To BCLK falling edge
$t_{TDDH}$	DSDATA1 Hold	15		ns	From BCLK falling edge
<b>TDM256 MODE (Slave, 48 kHz and 96 kHz)</b>					
$f_{AB}$	BCLK Frequency	$256 \times f_s$			
$t_{TBCH}$	BCLK High	17		ns	
$t_{TBCL}$	BCLK Low	17		ns	
$t_{TFS}$	FSTDM Setup	10		ns	To BCLK falling edge
$t_{TFH}$	FSTDM Hold	10		ns	From BCLK falling edge
$t_{TBDD}$	ASDATA Delay		15	ns	From BCLK rising edge
$t_{TDDS}$	DSDATA1 Setup	15		ns	To BCLK falling edge
$t_{TDDH}$	DSDATA1 Hold	15		ns	From BCLK falling edge
<b>TDM512 MODE (Master, 48 kHz)</b>					
$t_{TBD}$	BCLK Delay		40	ns	From MCLK rising edge
$t_{FSD}$	FSTDM Delay		5	ns	From BCLK rising edge
$t_{TABDD}$	ASDATA Delay		10	ns	From BCLK rising edge
$t_{TDDS}$	DSDATA1 Setup	15		ns	To BCLK falling edge
$t_{TDDH}$	DSDATA1 Hold	15		ns	From BCLK falling edge
<b>TDM512 MODE (Slave, 48 kHz)</b>					
$f_{AB}$	BCLK Frequency	$512 \times f_s$			
$t_{TBCH}$	BCLK High	17		ns	
$t_{TBCL}$	BCLK Low	17		ns	
$t_{TFS}$	FSTDM Setup	10		ns	To BCLK falling edge
$t_{TFH}$	FSTDM Hold	10		ns	From BCLK falling edge
$t_{TBDD}$	ASDATA Delay	15		ns	From BCLK rising edge
$t_{TDDS}$	DSDATA1 Setup	15		ns	To BCLK falling edge
$t_{TDDH}$	DSDATA1 Hold	15		ns	From BCLK falling edge
<b>AUXILIARY INTERFACE (48 kHz and 96 kHz)</b>					
$t_{AXDS}$	AAUXDATA Setup	10		ns	To AUXBCLK rising edge
$t_{AXDH}$	AAUXDATA Hold	10		ns	From AUXBCLK rising edge
$t_{DXD}$	DAUXDATA Delay	10		ns	From AUXBCLK falling edge
$f_{ABP}$	AUXBCLK Frequency	$64 \times f_s$		ns	
<b>Slave Mode</b>					
$t_{AXBH}$	AUXBCLK High	15		ns	
$t_{AXBL}$	AUXBCLK Low	15		ns	
$t_{AXLS}$	AUXLRCLK Setup	10		ns	To AUXBCLK rising edge
$t_{AXLH}$	AUXLRCLK Hold	10		ns	From AUXBCLK rising edge
<b>Master Mode</b>					
$t_{AUXBCLK}$	AUXBCLK Delay	20		ns	From MCLK rising edge
$t_{AUXLRCLK}$	AUXLRCLK Delay	15		ns	From AUXBCLK falling edge

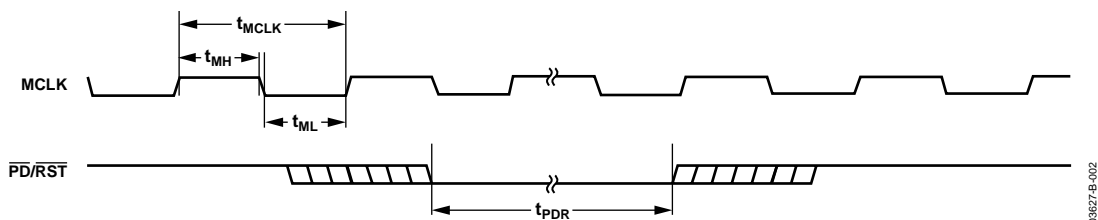

Figure 2. MCLK and  $\overline{PD/RST}$  Timing

## ABSOLUTE MAXIMUM RATINGS

$T_A = 25^\circ\text{C}$ , unless otherwise noted.

Table 3.

Parameter	Rating
AVDD, DVDD, ODVDD to AGND, DGND	-0.3 V to +6.0 V
AGND to DGND	-0.3 V to +0.3 V
Digital I/O Voltage to DGND	-0.3 V to ODVDD + 0.3 V
Analog I/O Voltage to AGND	-0.3 V to AVDD + 0.3 V
Operating Temperature Range Industrial (A Version)	-40°C to +85°C

Stresses above those listed under Absolute Maximum Ratings may cause permanent damage to the device. This is a stress rating only; functional operation of the device at these or any other conditions above those listed in the operational sections of this specification is not implied. Exposure to absolute maximum rating conditions for extended periods may affect device reliability.

## TEMPERATURE RANGE

Table 4.

Parameter	Min	Typ	Max	Unit
Specifications Guaranteed		+25		°C
Functionality Guaranteed	-40		+85	°C
Storage	-65		+150	°C

## ESD CAUTION

ESD (electrostatic discharge) sensitive device. Electrostatic charges as high as 4000 V readily accumulate on the human body and test equipment and can discharge without detection. Although this product features proprietary ESD protection circuitry, permanent damage may occur on devices subjected to high energy electrostatic discharges. Therefore, proper ESD precautions are recommended to avoid performance degradation or loss of functionality.



# AD1839A

## PIN CONFIGURATION AND FUNCTION DESCRIPTIONS

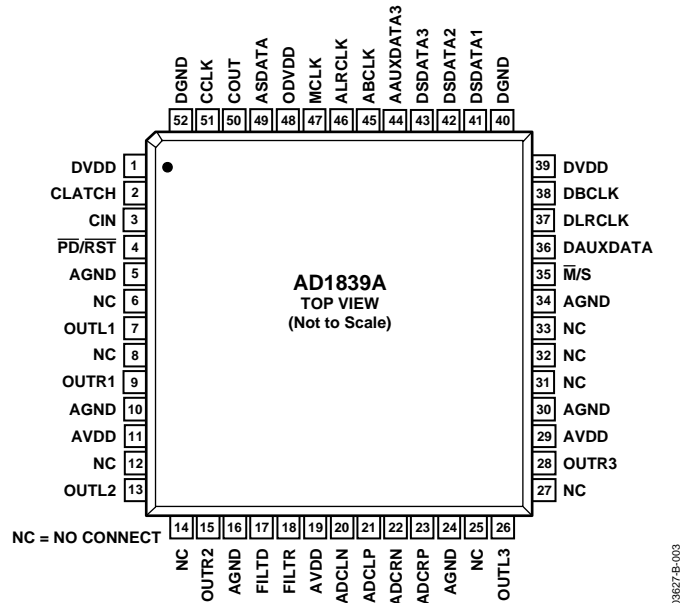

Figure 3. Pin Configuration

Table 5. Pin Function Descriptions

Pin No.	Mnemonic	Input/Output	Description
1, 39	DVDD		Digital Power Supply. Connect to digital 5 V supply.
2	CLATCH	I	Latch Input for Control Data.
3	CIN	I	Serial Control Input.
4	$\overline{\text{PD/RST}}$	I	Power-Down/Reset.
5, 10, 16, 24, 30, 34	AGND		Analog Ground.
6, 8, 12, 14, 25, 27, 31–33	NC		Not connected.
7, 13, 26	OUTLx	O	DACx Right Channel Negative Output.
9, 15, 28	OUTRx	O	DACx Right Channel Positive Output.
11, 19, 29	AVDD		Analog Power Supply. Connect to analog 5 V supply.
17	FILTD		Filter Capacitor Connection. Recommended 10 $\mu\text{F}/100 \text{ nF}$ .
18	FILTR		Reference Filter Capacitor Connection. Recommended 10 $\mu\text{F}/100 \text{ nF}$ .
20	ADCLN	I	ADC Left Channel Negative Input.
21	ADCLP	I	ADC Left Channel Positive Input.
22	ADCRN	I	ADC Right Channel Negative Input.
23	ADCRP	I	ADC Right Channel Positive Input.
35	$\overline{\text{M/S}}$	I	ADC Master/Slave Select.
36	DAUXDATA	O	Auxiliary DAC Output Data.
37	DLRCLK	I/O	DAC LR Clock.
38	DBCLK	I/O	DAC Bit Clock.
40, 52	DGND		Digital Ground.
41–43	DSDATAx	I	DACx Input Data (left and right channels).
44	AAUXDATA3	I	Auxiliary ADC3 Digital Input.
45	ABCLK	I/O	ADC Bit Clock.
46	ALRCLK	I/O	ADC LR Clock.
47	MCLK	I	Master Clock Input.
48	ODVDD		Digital Output Driver Power Supply.
49	ASDATA	O	ADC Serial Data Output.
50	COUT	O	Output for Control Data.
51	CCLK	I	Control Clock Input for Control Data.

# TYPICAL PERFORMANCE CHARACTERISTICS

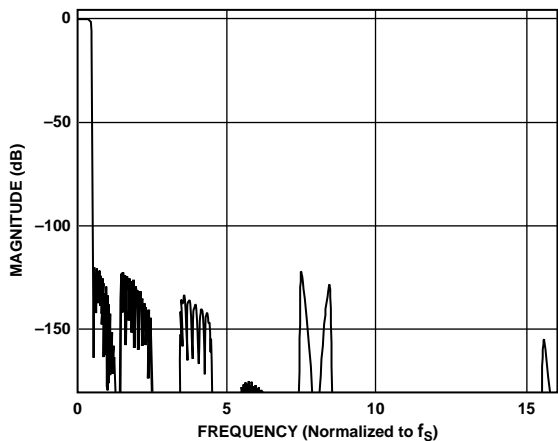

Figure 4. ADC Composite Filter Response

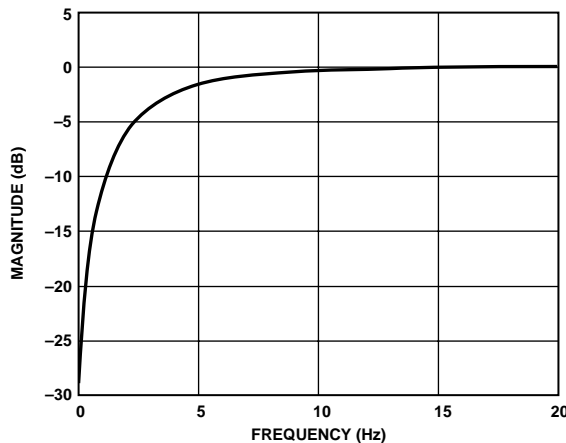

Figure 7. ADC High-Pass Filter Response,  $f_s = 96$  kHz

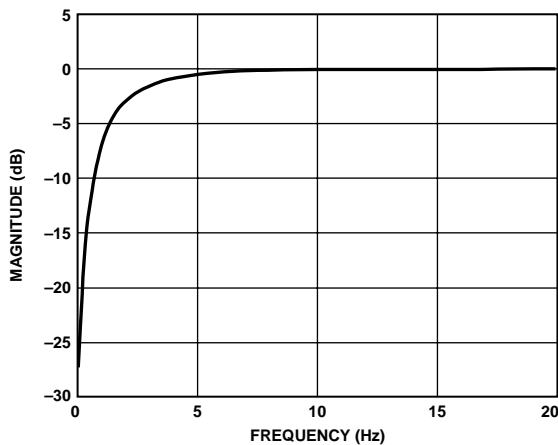

Figure 5. ADC High-Pass Filter Response,  $f_s = 48$  kHz

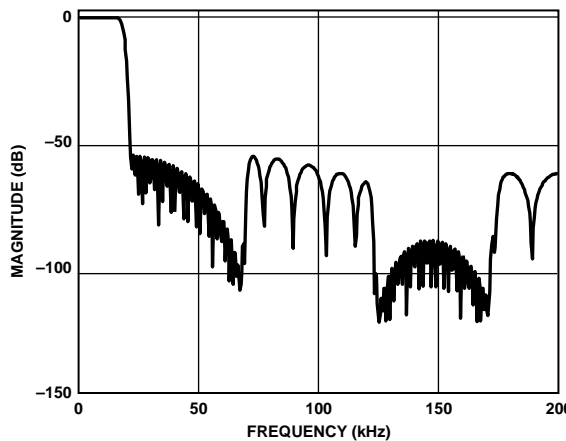

Figure 8. DAC Composite Filter Response,  $f_s = 48$  kHz

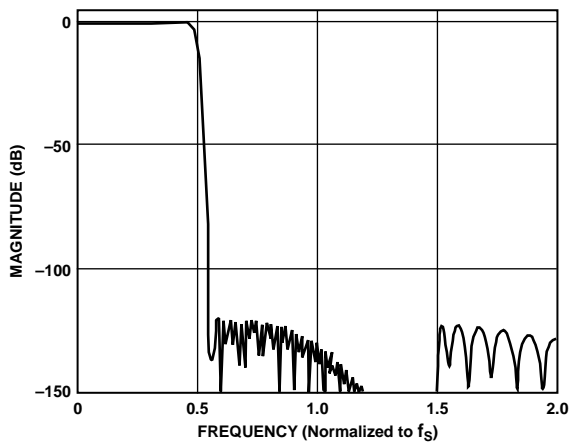

Figure 6. ADC Composite Filter Response (Pass-Band Section)

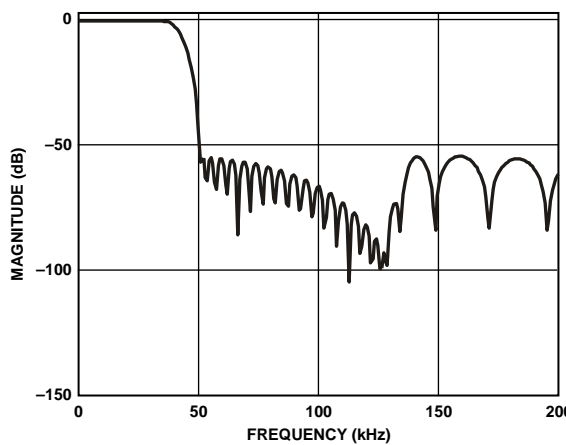

Figure 9. DAC Composite Filter Response,  $f_s = 96$  kHz

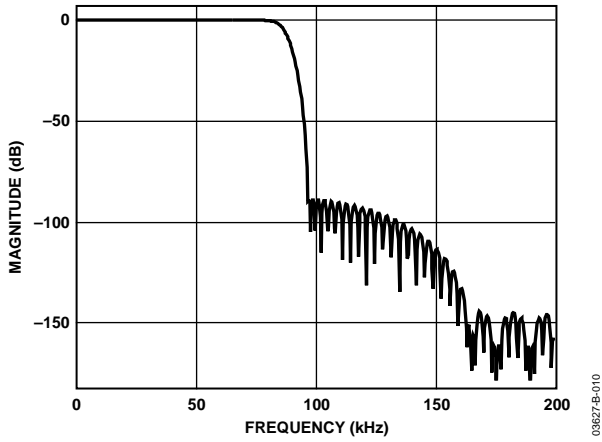

Figure 10. DAC Composite Filter Response,  $f_s = 192$  kHz

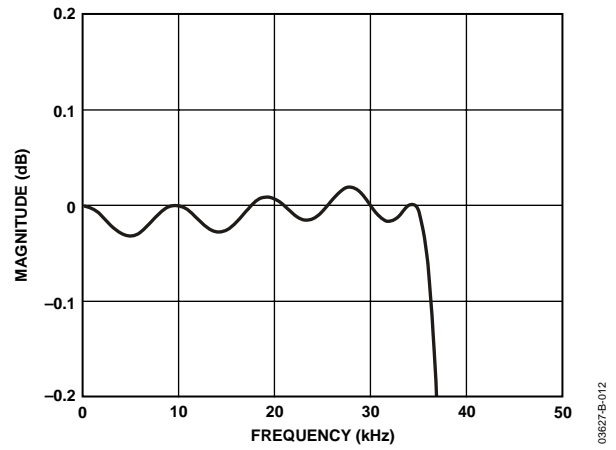

Figure 12. DAC Composite Filter Response,  $f_s = 96$  kHz (Pass-Band Section)

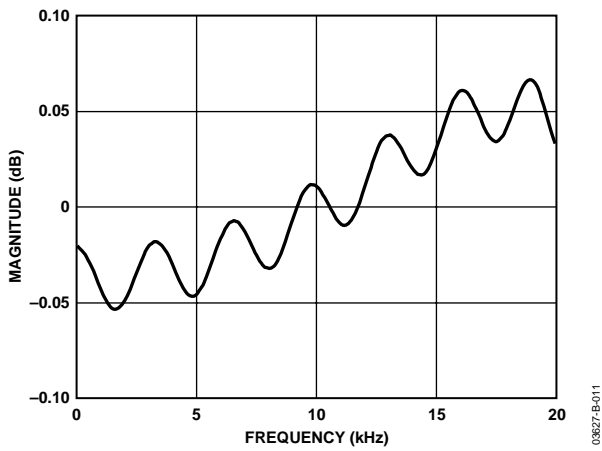

Figure 11. DAC Composite Filter Response,  $f_s = 48$  kHz (Pass-Band Section)

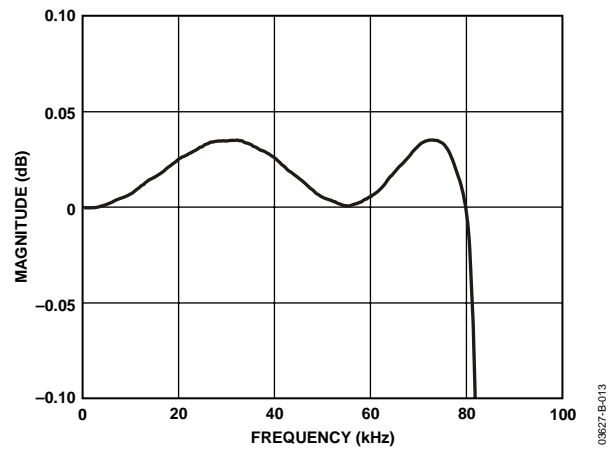

Figure 13. DAC Composite Filter Response,  $f_s = 192$  kHz (Pass-Band Section)

## TERMINOLOGY

### Dynamic Range

The ratio of a full-scale input signal to the integrated input noise in the pass band (20 Hz to 20 kHz), expressed in decibels. Dynamic range is measured with a  $-60$  dB input signal and is equal to  $(S/[THD + N]) + 60$  dB. Note that spurious harmonics are below the noise with a  $-60$  dB input, so the noise level establishes the dynamic range. The dynamic range is specified with and without an A-weight filter applied.

### Signal-to-(Total Harmonic Distortion + Noise) [S/(THD + N)]

The ratio of the root-mean-square (rms) value of the fundamental input signal to the rms sum of all other spectral components in the pass band, expressed in decibels.

### Pass Band

The region of the frequency spectrum unaffected by the attenuation of the digital decimator's filter.

### Pass-Band Ripple

The peak-to-peak variation in amplitude response from equal-amplitude input signal frequencies within the pass band, expressed in decibels.

### Stop Band

The region of the frequency spectrum attenuated by the digital decimator's filter to the degree specified by stop-band attenuation.

### Gain Error

With identical near full-scale inputs, the ratio of actual output to expected output, expressed as a percentage.

### Interchannel Gain Mismatch

With identical near full-scale inputs, the ratio of outputs of the two stereo channels, expressed in decibels.

### Gain Drift

Change in response to a near full-scale input with a change in temperature, expressed as parts-per-million (ppm) per °C.

### Crosstalk (EIAJ Method)

Ratio of response on one channel with a grounded input to a full-scale 1 kHz sine wave input on the other channel, expressed in decibels.

### Power Supply Rejection

With no analog input, signal present at the output when a 300 mV p-p signal is applied to the power supply pins, expressed in decibels of full scale.

### Group Delay

Intuitively, the time interval required for an input pulse to appear at the converter's output, expressed in microseconds. More precisely, the derivative of radian phase with respect to the radian frequency at a given frequency.

### Group Delay Variation

The difference in group delays at different input frequencies. Specified as the difference between the largest and the smallest group delays in the pass band, expressed in microseconds.

### Acronyms

**ADC**—Analog-to-digital converter.

**DAC**—Digital-to-analog converter.

**DSP**—Digital signal processor.

**IMCLK**—Internal master clock signal used to clock the ADC and DAC engines.

**MCLK**—External master clock signal applied to the AD1839A.

## FUNCTIONAL OVERVIEW

### ADCS

There are two ADC channels in the AD1839A, configured as a stereo pair. Each ADC has fully differential inputs. The ADC section can operate at a sample rate of up to 96 kHz. The ADCs include on-board digital decimation filters with 120 dB stop-band attenuation and linear phase response, operating at an oversampling ratio of 128 (for 48 kHz operation) or 64 (for 96 kHz operation).

The peak level information for each ADC may be read from the ADC Peak 0 and ADC Peak 1 registers. The data is supplied as a 6-bit word with a maximum range of 0 dB to –63 dB and a resolution of 1 dB. The registers hold peak information until read; after reading, the registers are reset so that new peak information can be acquired. (Refer to the register description in Table 10 for details of the format.) The two ADC channels have a common serial bit clock and a left-right framing clock. The clock signals are all synchronous with the sample rate.

The ADC digital pins, ABCLK and ALRCLK, can be set to operate as inputs or outputs by connecting the  $\overline{M/S}$  pin to ODVDD or DGND, respectively. When the pins are set as outputs, the AD1839A generates the timing signals. When the pins are set as inputs, the timing must be generated by the external audio controller.

### DACS

The AD1839A has six DAC channels arranged as three independent stereo pairs, with six single-ended analog outputs. Each channel has its own independently programmable attenuator, adjustable in 1,024 linear steps. Digital inputs are supplied through three serial data input pins (one for each stereo pair) and a common frame (DLRCLK) and bit clock (DBCLK). Alternatively, one of the packed data modes can be used to access all six channels on a single TDM data pin. A stereo replicate feature is included where the DAC data sent to the first DAC pair is also sent to the other DACs in the part. The AD1839A can accept DAC data at a sample rate of 192 kHz on DAC 1 only. The stereo replicate feature can then be used to copy the audio data to the other DACs.

Each of the output pins sits at a dc level of  $V_{REF}$  and swings  $\pm 1.4$  V for a 0 dB digital input signal. A single op amp, third-order, external low-pass filter is recommended to remove high frequency noise present on the output pins. Note that the use of op amps with low slew rate or low bandwidth may cause high frequency noise and tones to fold down into the audio band; care should be exercised in selecting these components.

The FILTD pin should be connected to an external grounded capacitor. This pin reduces the noise of the internal DAC bias circuitry, thus reducing the DAC output noise. At times, this capacitor may be eliminated with little effect on performance.

### DAC AND ADC CODING

The DAC and ADC output data stream is in a twos complement encoded format. A 16-bit, 20-bit, or 24-bit word width can be selected. The coding scheme is detailed in Table 6.

**Table 6. Coding Scheme**

Code	Level
01111.....1111	+FS
00000.....0000	0 (Ref level)
10000.....0000	–FS

### AD1839A CLOCKING SCHEME

By default, the AD1839A requires an MCLK signal that is 256 times the required sample frequency up to a maximum of 12.288 MHz. The AD1839A uses a clock scaler to double the clock frequency for use internally. The default setting of the clock scaler is Multiply by 2. The clock scaler can also be set to Multiply by 1 (bypass) or Multiply by 2/3. The clock scaler is controlled by programming the bits in the ADC Control 3 register. The internal MCLK signal, IMCLK, should not exceed 24.576 MHz to ensure correct operation.

The MCLK of the AD1839A should remain constant during normal operation of the DAC and ADC. If it is required to change the MCLK rate, the AD1838A should be reset. Also, if MCLK scaler needs to be modified so that the IMCLK does not exceed 24.576 MHz, this should be done during the internal reset phase of the AD1839A by programming the bits in the first 3,072 MCLK periods following the reset.

#### Selecting the DAC Sampling Rate

The AD1839A DAC engine has a programmable interpolator that allows the user to select different interpolation rates based on the required sample rate and MCLK value available. Table 7 shows the settings required for sample rates based on a fixed MCLK of 12.288 MHz.

**Table 7. DAC Sample Rate Settings**

Sample Rate	Interpolator Rate	DAC Control 1 Register
48 kHz	8×	000000xxxxxxxx00
96 kHz	4×	000000xxxxxxxx01
192 kHz	2×	000000xxxxxxxx10

#### Selecting an ADC Sample Rate

The AD1839A ADC engine has a programmable decimator that allows the user to select the sample rate based on the MCLK value. By default, the output sample rate is  $IMCLK/512$ . To achieve a sample rate of  $IMCLK/256$ , the sample rate bit in the ADC Control 1 register should be set as shown in Table 8.

**Table 8. ADC Sample Rate Settings**

Sample Rate	ADC Control 1 Register
$IMCLK/512$	1100000xx0xxxxxx (48 kHz)
$IMCLK/256$	1100000xx1xxxxxx (96 kHz)

To maintain the highest performance possible, the clock jitter of the master clock signal should be limited to less than 300 ps rms, measured using the edge-to-edge technique. Even at these levels, extra noise or tones may appear in the DAC outputs if the jitter spectrum contains large spectral peaks. It is highly recommended that the master clock be generated by an independent crystal oscillator. In addition, it is especially important that the clock signal not be passed through an FPGA or other large digital chip before being applied to the AD1839A. In most cases, this induces clock jitter because the clock signal is sharing common power and ground connections with unrelated digital output signals.

**RESET AND POWER-DOWN**

$\overline{PD/RST}$  powers down the chip and sets the control registers to their default settings. After  $\overline{PD/RST}$  is deasserted, an initialization routine runs inside the device to clear all memories to zero. The initialization lasts approximately 20 LRCLK intervals. During this time, it is recommended that no SPI writes occur.

**POWER SUPPLY AND VOLTAGE REFERENCE**

The AD1839A is designed for 5 V supplies. Separate power supply pins are provided for the analog and digital sections. These pins should be bypassed with 100 nF ceramic chip capacitors, as close to the pins as possible, to minimize noise

pickup. A bulk aluminum electrolytic capacitor of at least 22  $\mu$ F should also be provided on the same PC board as the codec. For critical applications, improved performance is obtained with separate supplies for the analog and digital sections. If this is not possible, it is recommended that the analog and digital supplies be isolated by two ferrite beads in series with the bypass capacitor of each supply. It is important that the analog supply be as clean as possible.

The internal voltage reference is brought out on the FILTR pin and should be bypassed as close as possible to the chip, with a parallel combination of 10  $\mu$ F and 100 nF. The reference voltage may be used to bias external op amps to the common-mode voltage of the analog input and output signal pins. The current drawn from the  $V_{REF}$  pin should be limited to less than 50  $\mu$ A.

**SERIAL CONTROL PORT**

The AD1839A has an SPI compatible control port to permit programming the internal control registers for the ADCs and DACs, and for reading the ADC signal levels from the internal peak detectors. The SPI port is a 4-wire serial control port. The format is similar to the Motorola SPI format except the input data-word is 16 bits wide. The maximum serial bit clock frequency is 12.5 MHz and may be completely asynchronous to the sample rate of the ADCs and DACs. Figure 15 shows the format of the SPI signal.

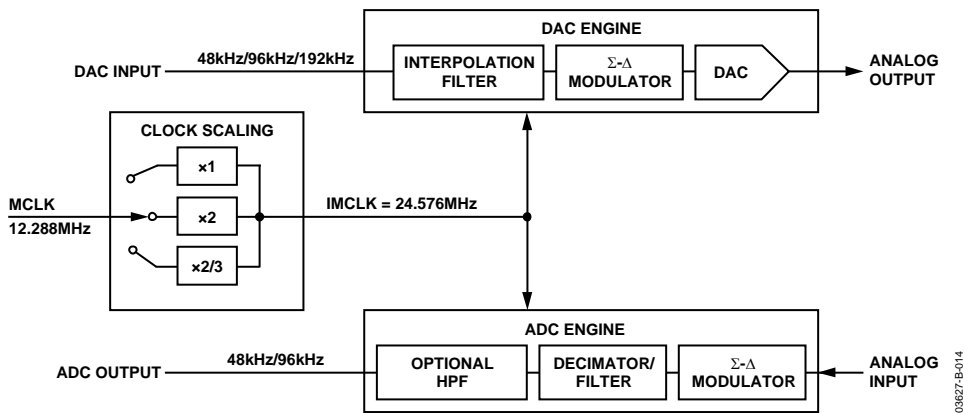

Figure 14. Modular Clocking Scheme

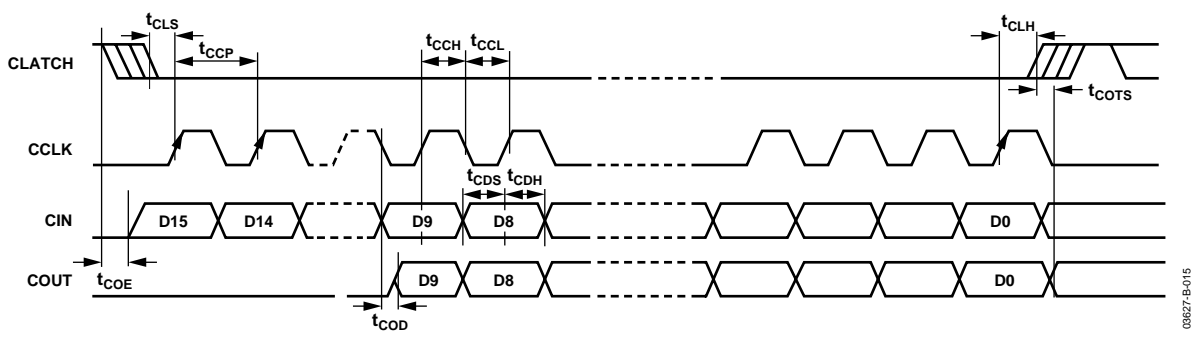

Figure 15. Format of SPI Timing

## SERIAL DATA PORTS—DATA FORMAT

The ADC serial data output mode defaults to the popular I<sup>2</sup>S format, where the data is delayed by 1 BCLK interval from the edge of the LRCLK. By changing Bits 6 to 8 in ADC Control Register 2, the serial mode can be changed to right-justified (RJ), left-justified DSP (DSP), or left-justified (LJ). In the RJ mode, it is necessary to set Bits 4 and 5 to define the width of the data-word. The DAC serial data input mode defaults to I<sup>2</sup>S. By changing Bits 5, 6, and 7 in DAC Control Register 1, the mode can be changed to RJ, DSP, LJ, or Packed Mode 256. The word width defaults to 24 bits but can be changed by reprogramming Bits 3 and 4 in DAC Control Register 1.

## PACKED MODES

The AD1839A has a packed mode that allows a DSP or other controller to write to all DACs and read all ADCs using one input data pin and one output data pin. Packed Mode 256 refers to the number of BCLKs in each frame. The LRCLK is low while data from a left-channel DAC or ADC is on the data pin; LRCLK is high while data from a right-channel DAC or ADC is on the data pin. DAC data is applied on the DSDATA1 pin, and ADC data is available on the ASDATA pin. Figure 19 to Figure 24 show the timing for the packed mode. Packed mode is available for 48 kHz and 96 kHz.

## AUXILIARY TIME DIVISION MULTIPLEXING (TDM) MODE

A special auxiliary mode is provided to allow three external stereo ADCs and one external stereo DAC to be interfaced to the AD1839A to provide 8-in/8-out operation. In addition, this mode supports a glueless interface to a single SHARC DSP serial port, allowing a SHARC DSP to access all eight channels of analog I/O. In this special mode, many pins are redefined; see Table 9 for a list of redefined pins.

The auxiliary and TDM interfaces are independently configurable to operate as masters or slaves. When the auxiliary interface is set as a master, by programming the auxiliary mode bit in ADC Control Register 2, AUXLRCLK and AUXBCLK are generated by the AD1839A. When the auxiliary interface is set as a slave, AUXLRCLK and AUXBCLK need to be generated by an external ADC, as shown in Figure 27.

The TDM interface can be set to operate as a master or slave by connecting the  $\overline{M/S}$  pin to DGND or ODVDD, respectively. In master mode, the FSTDM and BCLK signals are outputs and are generated by the AD1839A. In slave mode, the FSTDM and BCLK are inputs and should be generated by the SHARC. Both 48 kHz and 96 kHz operations are available (based on a 12.288 MHz or 24.576 MHz MCLK) in this mode.

**Table 9. Pin Function Changes in Auxiliary Mode**

Pin Name	I <sup>2</sup> S Mode	Auxiliary Mode
ASDATA (O)	I <sup>2</sup> S Data Out, Internal ADC	TDM Data Out to SHARC.
DSDATA1 (I)	I <sup>2</sup> S Data In, Internal DAC1	TDM Data In from SHARC.
DSDATA2 (I)/AAUXDATA1 (I)	I <sup>2</sup> S Data In, Internal DAC2	AUX-I <sup>2</sup> S Data In 1 (from external ADC).
DSDATA3 (I)/AAUXDATA2 (I)	I <sup>2</sup> S Data In, Internal DAC3	AUX-I <sup>2</sup> S Data In 2 (from external ADC).
AAUXDATA3 (I)	Not Connected	AUX-I <sup>2</sup> S Data In 3 (from external ADC).
ALRCLK (O)	LRCLK for ADC	TDM Frame Sync Out to SHARC (FSTDM).
ABCLK (O)	BCLK for ADC	TDM BCLK Out to SHARC.
DLRCLK (I)/AUXLRCLK (I/O)	LRCLK In/Out Internal DACs	AUX LRCLK In/Out. Driven by external LRCLK from ADC in slave mode. In master mode, driven by MCLK/512.
DBCLK (I)/AUXBCLK (I/O)	BCLK In/Out Internal DACs	AUX BCLK In/Out. Driven by external BCLK from ADC in slave mode. In master mode, driven by MCLK/8.
DAUXDATA (O)	Not Connected	AUX-I <sup>2</sup> S Data Out (to external DAC).

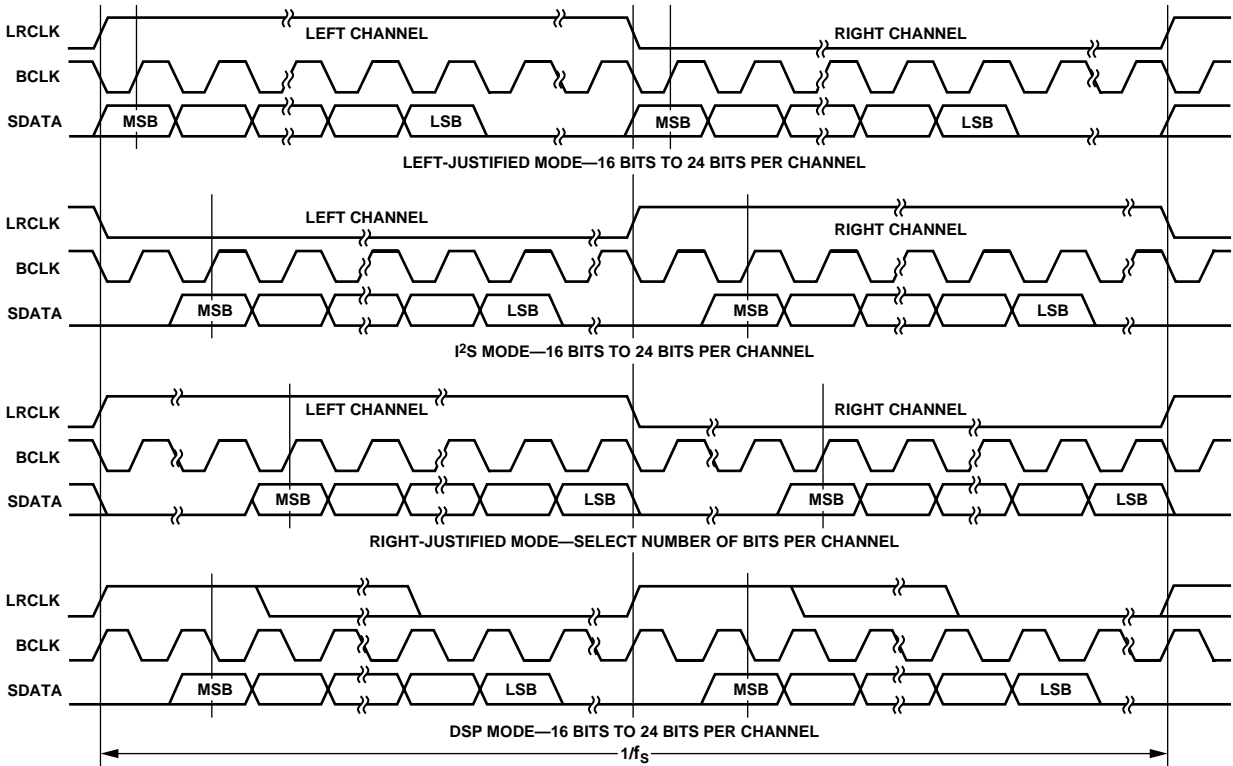

NOTES

1. DSP MODE DOES NOT IDENTIFY CHANNEL.
2. LRCLK NORMALLY OPERATES AT  $f_s$  EXCEPT FOR DSP MODE, WHICH IS  $2 \times f_s$ .
3. BCLK FREQUENCY IS NORMALLY  $64 \times$  LRCLK BUT MAY BE OPERATED IN BURST MODE.

03827-B-016

Figure 16. Stereo Serial Modes

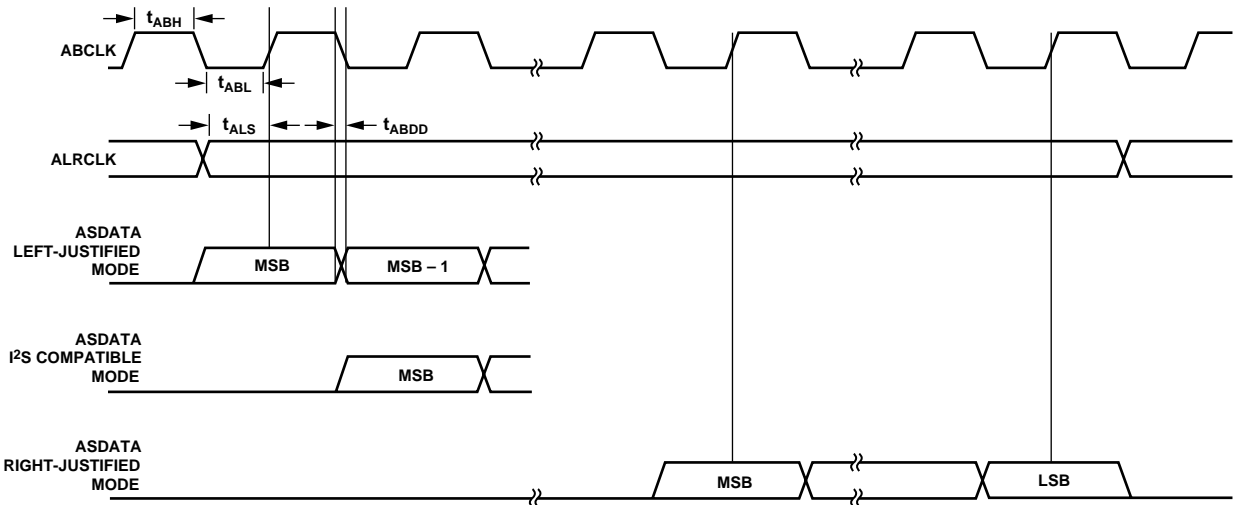

Figure 17. ADC Serial Mode Timing

03827-B-017

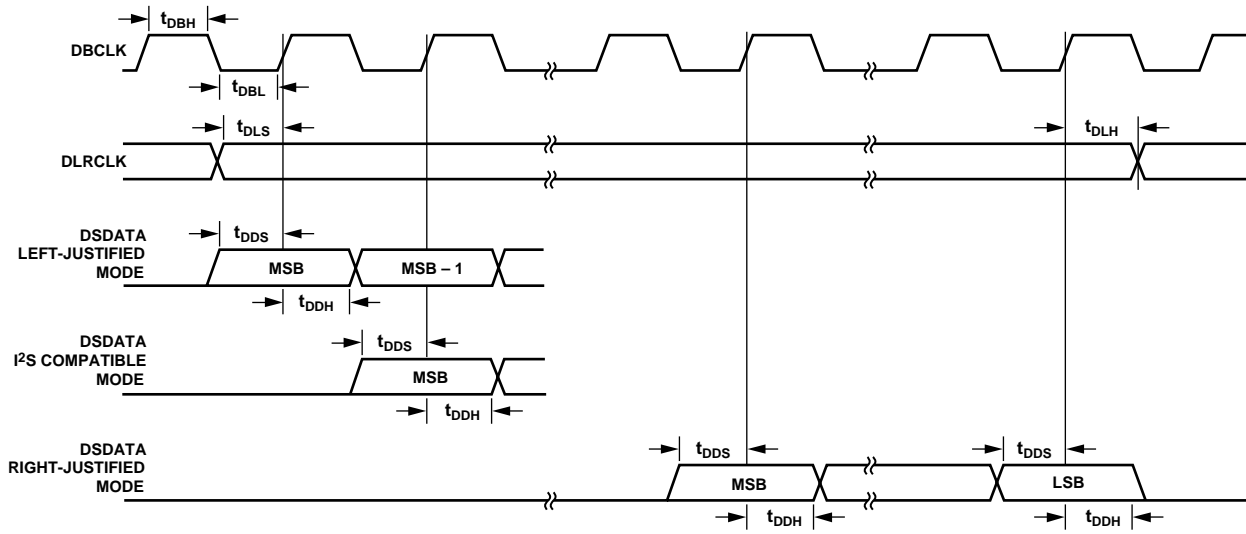

Figure 18. DAC Serial Mode Timing

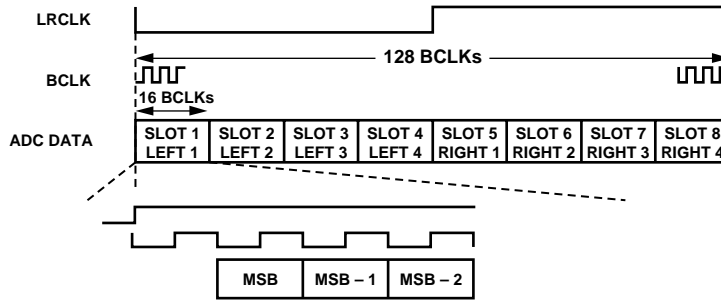

Figure 19. ADC Packed Mode 128

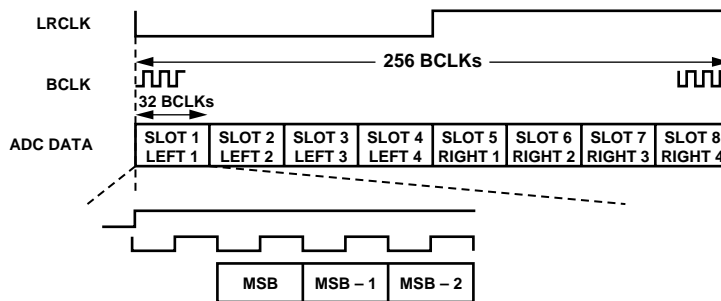

Figure 20. ADC Packed Mode 256

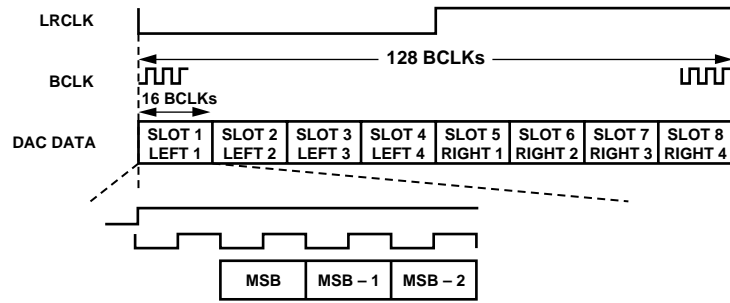

Figure 21. DAC Packed Mode 128

03827-B-021

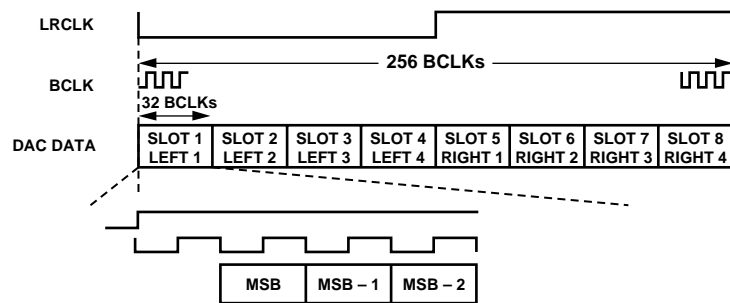

Figure 22. DAC Packed Mode 256

03827-B-022

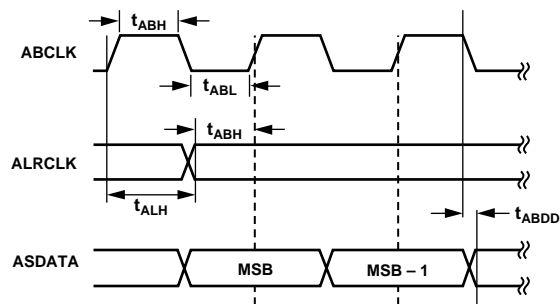

Figure 23. ADC Packed Mode Timing

03827-B-024

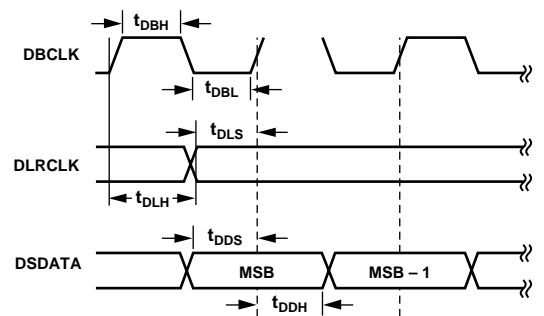

Figure 24. DAC Packed Mode Timing

03827-B-025

# AD1839A

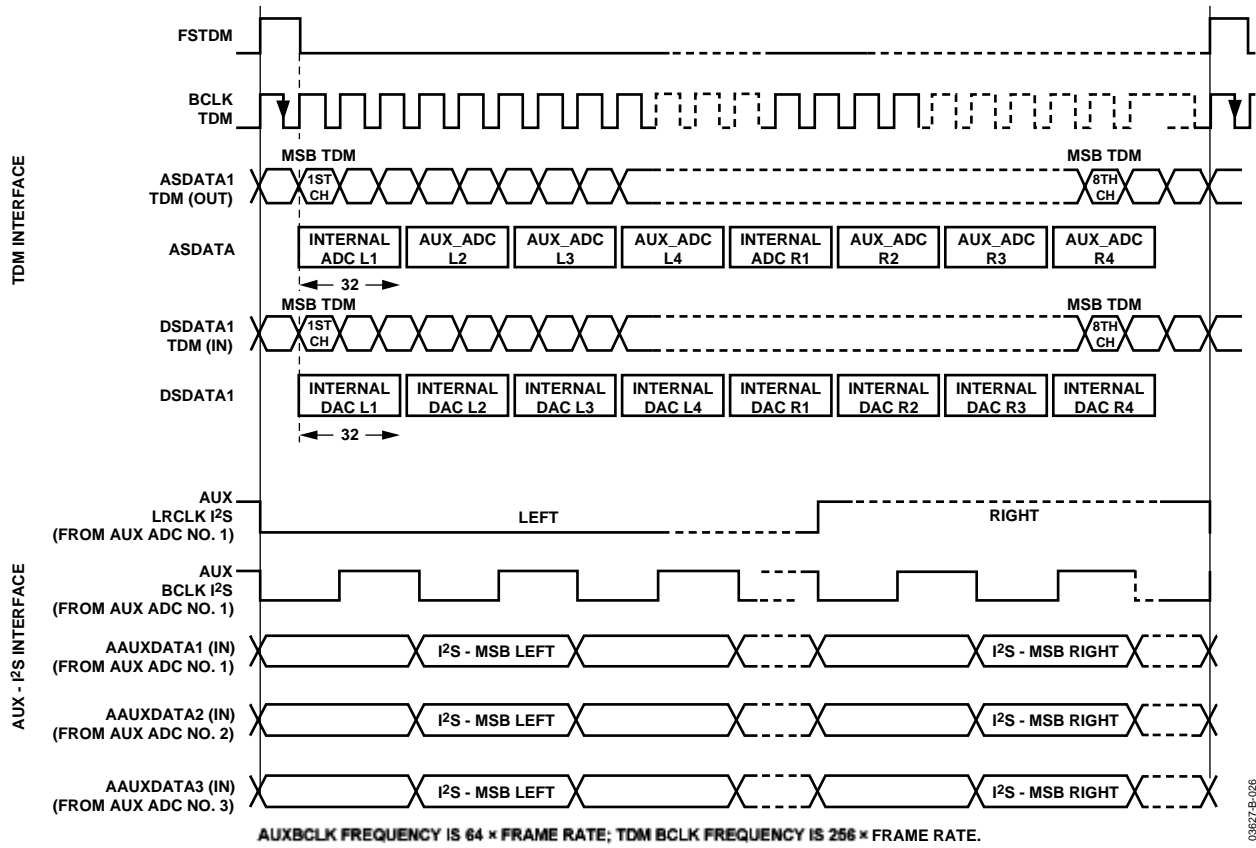

Figure 25. Auxiliary Mode Timing

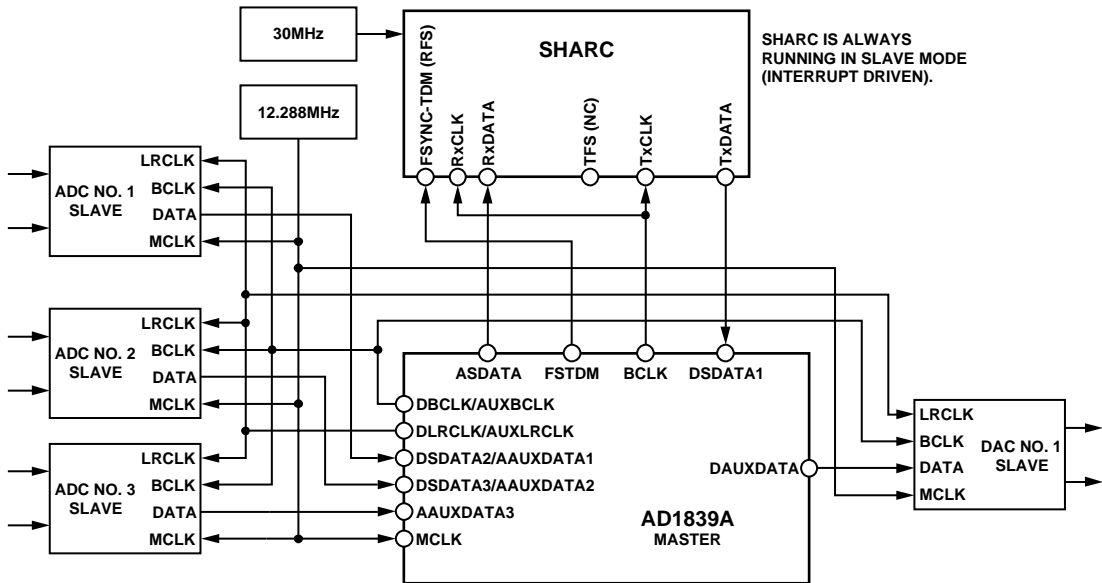

Figure 26. Auxiliary Mode Connection (Master Mode) to SHARC

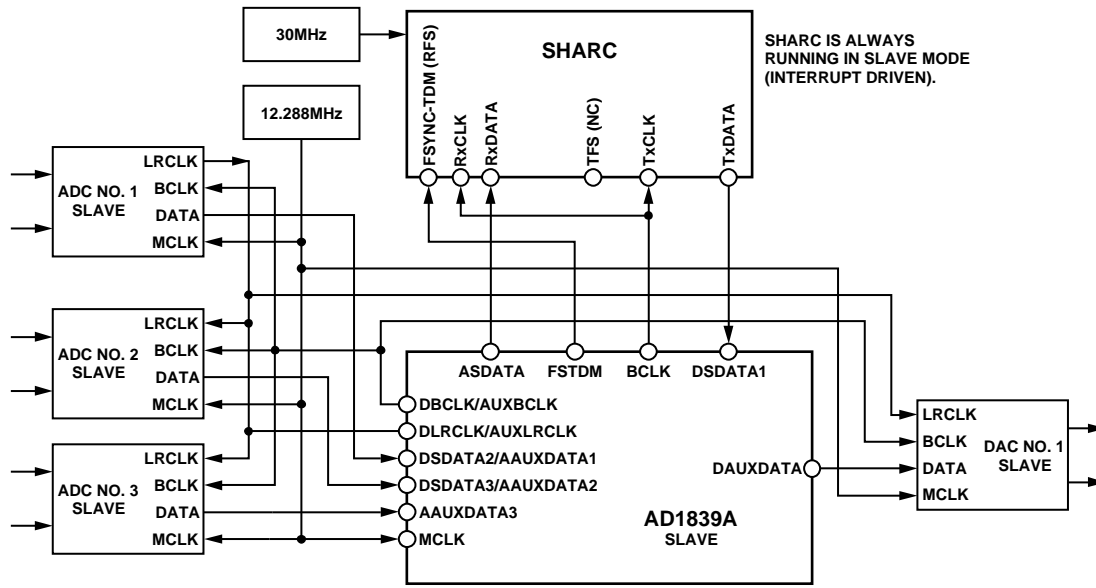

Figure 27. Auxiliary Mode Connection (Slave Mode) to SHARC

## CONTROL/STATUS REGISTERS

The AD1839A has 13 control registers, 11 of which are used to set the operating mode of the part. The other two registers, ADC Peak 0 and ADC Peak 1, are read-only and should not be programmed. Each of the registers is 10 bits wide with the exception of the ADC peak reading registers, which are 6 bits wide. Writing to a control register requires a 16-bit data frame to be transmitted. Bits 15 to 12 are the address bits of the required register. Bit 11 is a read/write bit. Bit 10 is reserved and should always be programmed to 0. Bits 9 to 0 contain the 10-bit value that is to be written to the register, or, in the case of a read operation, the 10-bit register contents. Figure 15 shows the format of the SPI read and write operation.

### DAC Control Registers

The AD1839A register map has eight registers that are used to control the functionality of the DAC section of the part. The function of the bits in these registers is discussed next.

#### Sample Rate

These bits control the sample rate of the DACs. Based on a 24.576 MHz IMCLK, sample rates of 48 kHz, 96 kHz, and 192 kHz are available. The MCLK scaling bits in ADC Control 3 should be programmed appropriately, based on the master clock frequency.

#### Power-Down/Reset

This bit controls the power-down status of the DAC section. By default, normal mode is selected; by setting this bit, the digital section of the DAC stage can be put into a low power mode, thus reducing the digital current. The analog output section of the DAC stage is not powered down.

### DAC Data-Word Width

These two bits set the word width of the DAC data. Compact disk (CD) compatibility may require 16 bits, but many modern digital audio formats require 24-bit sample resolution.

### DAC Data Format

The AD1839A serial data interface can be configured to be compatible with a choice of popular interface formats, including I<sup>2</sup>S, LJ, RJ, or DSP modes. Details on these interface modes are provided in the Serial Data Ports—Data Format section.

### De-emphasis

The AD1839A provides built-in de-emphasis filtering for the three standard sample rates of 32.0 kHz, 44.1 kHz, and 48 kHz.

### Mute DAC

Each of the six DACs in the AD1839A has its own independent mute control. Setting the appropriate bit mutes the DAC output. The AD1839A uses a clickless mute function that attenuates the output to approximately –100 dB over a number of cycles.

### Stereo Replicate

Setting this bit copies the digital data sent to the stereo pair DAC1 to the three other stereo DACs in the system. This allows all three stereo DACs to be driven by one digital data stream. Note that in this mode, DAC data sent to the other DACs is ignored.

### DAC Volume Control

Each DAC in the AD1839A has its own independent volume control. The volume of each DAC can be adjusted in 1,024 linear steps by programming the appropriate register. The default value for this register is 1023, which provides no attenuation, that is, full volume.

# AD1839A

## ADC Control Registers

The AD1839A register map has five registers that are used to control the functionality and read the status of the ADCs. The function of the bits in each of these registers is discussed below.

### ADC Peak Level

These two registers store the peak ADC result from each channel when the ADC peak readback function is enabled. The peak result is stored as a 6-bit number from 0 dB to –63 dB in 1 dB steps. The value contained in the register is reset once it has been read, allowing for continuous level adjustment as required. Note that the ADC peak level registers use the six most significant bits in the register to store the results.

### Sample Rate

This bit controls the sample rate of the ADCs. Based on a 24.576 MHz IMCLK, sample rates of 48 kHz and 96 kHz are available. The MCLK scaling bits in ADC Control 3 should be programmed appropriately, based on the master clock frequency.

### ADC Power-Down

This bit controls the power-down status of the ADC section and operates in a manner similar to the DAC power-down.

### High-Pass Filter

The ADC signal path has a digital high-pass filter. Enabling this filter removes the effect of any dc offset in the analog input signal from the digital output codes.

### ADC Data-Word Width

These two bits set the word width of the ADC data.

### ADC Data Format

The AD1839A serial data interface can be configured to be compatible with a choice of popular interface formats, including I<sup>2</sup>S, LJ, RJ, or DSP modes.

### Master/Slave Auxiliary Mode

When the AD1839A is operating in the auxiliary mode, the auxiliary ADC control pins, AUXBCLK and AUXLRCLK, which connect to the external ADCs, can be set to operate as a master or slave. If the pins are set in slave mode, one of the external ADCs should provide the LRCLK and BCLK signals.

### ADC Peak Readback

Setting this bit enables ADC peak reading. See the ADCs section for more information.

Table 10. Control Register Map

Register Address	Register Name	Description	Type	Width	Reset Setting (Hex)
0000	DACCTRL1	DAC Control 1	R/W	10	000
0001	DACCTRL2	DAC Control 2	R/W	10	000
0010	DACVOL1	DAC Volume—Left 1	R/W	10	3FF
0011	DACVOL2	DAC Volume—Right 1	R/W	10	3FF
0100	DACVOL3	DAC Volume—Left 2	R/W	10	3FF
0101	DACVOL4	DAC Volume—Right 2	R/W	10	3FF
0110	DACVOL5	DAC Volume—Left 3	R/W	10	3FF
0111	DACVOL6	DAC Volume—Right 3	R/W	10	3FF
1000	DACVOL7	DAC Volume—Left 4	R/W	10	3FF
1001	DACVOL8	DAC Volume—Right 4	R/W	10	3FF
1010	ADCPeak0	ADC Left Peak	R	6	000
1011	ADCPeak1	ADC Right Peak	R	6	000
1100	ADCCTRL1	ADC Control 1	R/W	10	000
1101	ADCCTRL2	ADC Control 2	R/W	10	000
1110	ADCCTRL3	ADC Control 3	R/W	10	000
1111	Reserved	Reserved	R/W	10	Reserved

Table 11. DAC Control 1

Address	R/W	RES	Function				
			De-emphasis	DAC Data Format	DAC Data-Word Width	Power-Down Reset	Sample Rate
15, 14, 13, 12 0000	11 0	10 0	9, 8 00 = None 01 = 44.1 kHz 10 = 32.0 kHz 11 = 48.0 kHz	7, 6, 5 000 = I2S 001 = RJ 010 = DSP 011 = LJ 100 = Packed 256 101 = Packed 128 110 = Reserved 111 = Reserved	4, 3 00 = 24 Bits 01 = 20 Bits 10 = 16 Bits 11 = Reserved	2 0 = Normal 1 = Power-Down	1, 0 00 = 8 × (48 kHz) 01 = 4 × (96 kHz) 10 = 2 × (192 kHz) 11 = 8 × (48 kHz)

Table 12. DAC Control 2

Address	R/W	RES	Reserved	Function											
				Stereo Replicate	MUTE DAC										
					Reserved	Reserved	OUTR3	OUTL3	OUTR2	OUTL2	OUTR1	OUTL1			
15, 14, 13, 12 0001	11 0	10 0	9 0	8 0 = Off 1 = Replicate	7 0 = On 1 = Mute	6 0 = On 1 = Mute	5 0 = On 1 = Mute	4 0 = On 1 = Mute	3 0 = On 1 = Mute	2 0 = On 1 = Mute	1 0 = On 1 = Mute	0 0 = On 1 = Mute			

Table 13. DAC Volume Control

Address	R/W	RES	Function
			DAC Volume
15, 14, 13, 12	11	10	9, 8, 7, 6, 5, 4, 3, 2, 1, 0
0010 = DACL1 0011 = DACR1 0100 = DACL2 0101 = DACR2 0110 = DACL3 0111 = DACR3	0	0	000000000 = Mute 000000001 = 1/1023 000000010 = 2/1023 111111110 = 1022/1023 111111111 = 1023/1023

Table 14. ADC Peak

Address	R/W	RES	Function	
			Six Data Bits	Four Fixed Bits
15, 14, 13, 12	11	10	9, 8, 7, 6, 5, 4	3, 2, 1, 0
1010 = Left ADC 1011 = Right ADC	1	0	000000 = 0.0 dBFS 000001 = -1.0 dBFS 000010 = -2.0 dBFS  111111 = -63.0 dBFS	0000  These four bits are always 0.

Table 15. ADC Control 1

Address	R/W	RES	Function				
			Reserved	Filter	ADC Power-Down	Sample Rate	Reserved
15, 14, 13, 12	11	10	9	8	7	6	5, 4, 3, 2, 1, 0
1100	0	0	0	0 = All Pass 1 = High-Pass	0 = Normal 1 = Power-Down	0 = 48 kHz 1 = 96 kHz	0, 0, 0, 0, 0, 0 0, 0, 0, 0, 0, 0

# AD1839A

Table 16. ADC Control 2

Address	R/ $\overline{W}$	RES	Function						
			Master/Slave Aux Mode	ADC Data Format	ADC Data-Word Width	AUXDATA	RES	ADC MUTE	
								Right	Left
15, 14, 13, 12	11	10	9	8, 7, 6	5, 4	3	2	1	0
1101	0	0	0 = Slave 1 = Master	000 = I <sup>2</sup> S 001 = RJ 010 = DSP 011 = LJ 100 = Packed 256 101 = Packed 128 110 = Auxiliary 256 111 = Auxiliary 512	00 = 24 Bits 01 = 20 Bits 10 = 16 Bits 11 = Reserved	0 = Off 1 = On	0	0 = On 1 = Mute	0 = On 1 = Mute

Table 17. ADC Control 3

Address	R/ $\overline{W}$ RES	RES	Reserved	Function			
				IMCLK Clocking Scaling	ADC Peak Readback	DAC Test Mode	ADC Test Mode
15, 14, 13, 12	11	10	9, 8	7, 6	5	4, 3, 2	1, 0
1110	0	0	0, 0	00 = MCLK × 2 01 = MCLK 10 = MCLK × 2/3 11 = MCLK × 2	0 = Disabled Peak Readback 1 = Enabled Peak Readback	000 = Normal Mode All Others Reserved	00 = Normal Mode All Others Reserved

## CASCADE MODE

### Dual AD1839A Cascade

The AD1839A can be cascaded to an additional AD1839A that, in addition to six external stereo ADCs and two external stereo DACs, can be used to create a 32-channel audio system with 16 inputs and 16 outputs. The cascade is designed to connect to a SHARC DSP and operates in a time division multiplexing (TDM) format. Figure 28 shows the connection diagram for cascade operation. The digital interface for both parts must be set to operate in Auxiliary 512 mode by programming ADC Control Register 2. AD1839A Device 1 is set as the master device by connecting the  $\overline{M/S}$  pin to DGND; AD1839A Device 2 is set as a slave device by connecting the  $\overline{M/S}$  to ODVDD. Both devices should be run from the same MCLK and  $\overline{PD/RST}$  signals to ensure that they are synchronized. With

Device 1 set as a master, it generates the frame-sync and bit clock signals. These signals are sent to the SHARC and Device 2, ensuring that both know when to send and receive data.

The cascade can be thought of as two 256-bit shift registers, one for each device. At the beginning of a sample interval, the shift registers contain the ADC results from the previous sample interval. The first shift register (Device 1) clocks data into the SHARC and clocks in data from the second shift register (Device 2). While this is happening, the SHARC is sending DAC data to the second shift register. By the end of the sample interval, all 512 bits of ADC data in the shift registers have been clocked into the SHARC and replaced by DAC data, which is subsequently written to the DACs. Figure 29 shows the timing diagram for the cascade operation.

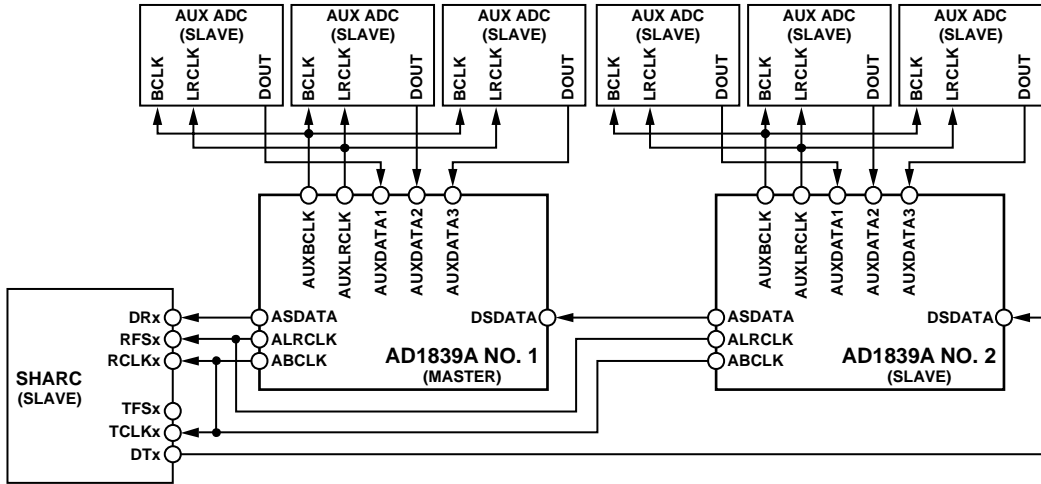

Figure 28. Dual AD1839A Cascade

03827-B-029

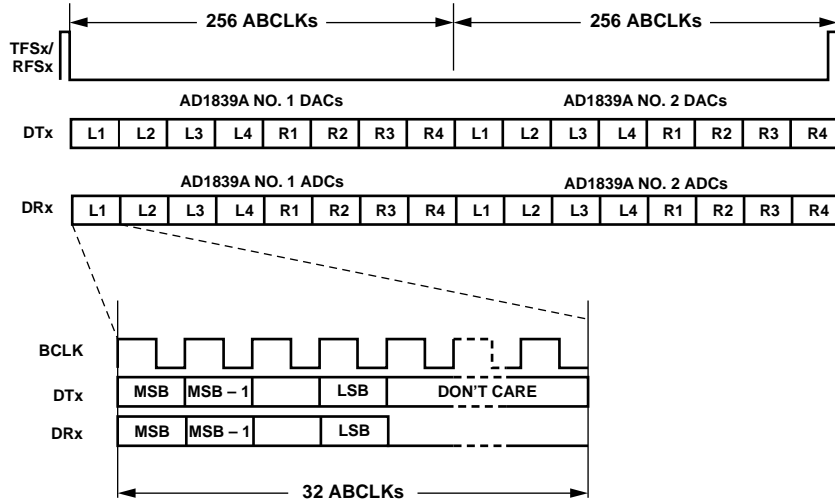

Figure 29. Dual AD1839A Cascade Timing

03827-B-030

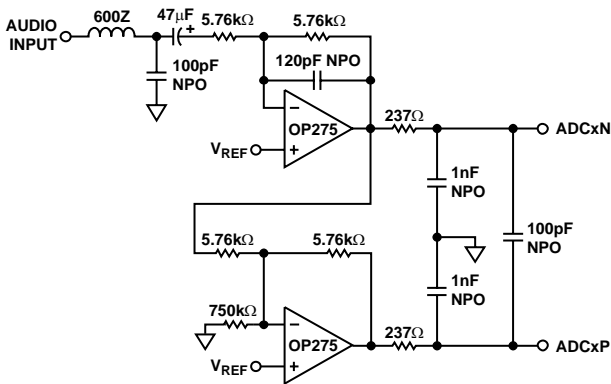

Figure 30. Typical ADC Input Filter Circuit

03827-B-031

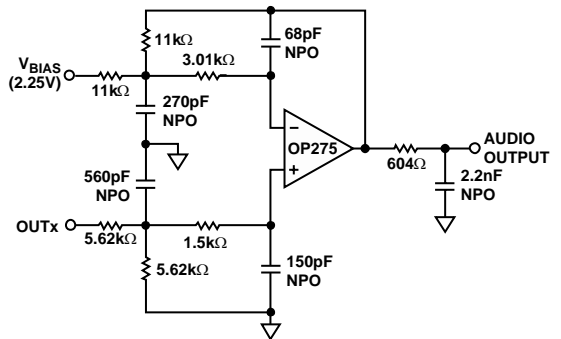

Figure 31. Typical DAC Output Filter Circuit

03827-B-032



## Looking for pricing, stock, or lifecycle information?

Click below to explore more details on WIN SOURCE:

- ⊖ [View AD1839AS](#) on WIN SOURCE
- ⊖ [Analog Devices Inc.](#) Information

## Optimize Your Supply Chain with WIN SOURCE Solutions

- ✓ Global Sourcing Solution
- ✓ Obsolete Management
- ✓ Cost Control Management
- ✓ Shortage Management
- ✓ Alternative Solution
- ✓ Excess Inventory Management