

## 3-Phase Brushless DC Sinusoidal Sensorless Fan Motor Driver

### Features

- Position Sensorless BLDC Drivers (No Hall Sensor Required)
- 180° Sinusoidal Drive, for High Efficiency and Low Acoustic Noise
- Support 2V to 14V Power Supplies
- Speed Control Through PAM and/or PWM
- Built-in Frequency Generator (FG Output Signal)
- Built-in Lock-up Protection and Automatic Recovery Circuit (External Capacitor not Necessary)
- Built-in Over Current Limitation and Short Circuit Protection
- Built-in Thermal Shutdown Protection
- Thermally Enhanced SOP-8 Package for MTD6501C and MTD6501G (Maximum Output Current – 800 mA);
- MSOP-10L Package for MTD6501D (Maximum Output Current – 500 mA)
- 20 kHz PWM Output Frequency for MTD6501C/D and 23 kHz for MTD6501G
- Boost Mode (Optional Back Electromotive Force (BEMF) Pre-amplification in MTD6501D)
- No External Tuning Required

The MTD6501C/D/G devices are formerly products of Advanced Silicon.

### Description

The MTD6501C/D/G devices are 3-phase, full-wave drivers for brushless sensorless DC motors. They feature 180° sinusoidal drive, high torque output, and silent drive. Due to their adaptive features and wide power-supply range capabilities (2V to 14V), they are intended to cover a wide range of motor characteristics, while requiring no external tuning from the user. Speed control can be achieved through either power supply modulation or pulse-width modulation (using the PWM digital input pin).

Due to the compact packaging and minimum bill of materials (power transistors incorporated, no Hall sensor, no external tuning), they are best suited for low-cost fan applications requiring high efficiency and low acoustic noise, such as CPU cooling fans. Frequency generator output enables precision speed control in closed-loop applications. The MTD6501C/D/G drivers include a Lock-up Protection mode, which turns off the output current when the motor is under lock condition, and an automatic recovery that enables the fan to run when the lock condition is removed. Motor overcurrent limitation, short-circuit protection and thermal-shutdown protection are also included.

The MTD6501C and the MTD6501G are available in a compact thermally-enhanced SOP-8 package, while the MTD6501D is available in the MSOP-10L package.

### Package Types

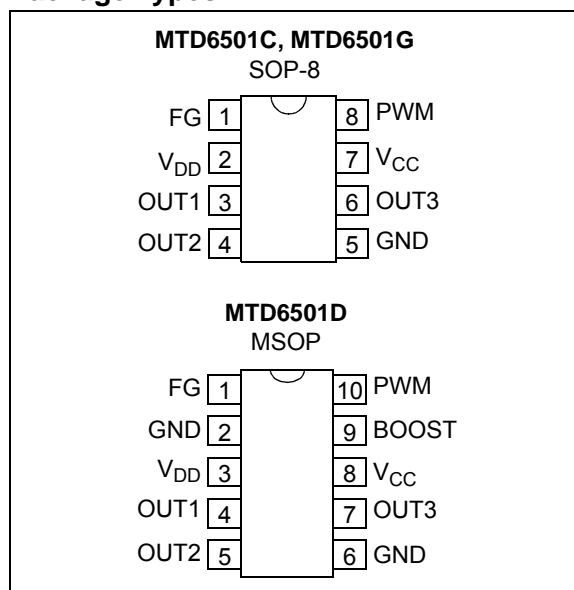

# MTD6501C/D/G

## Functional Block Diagram

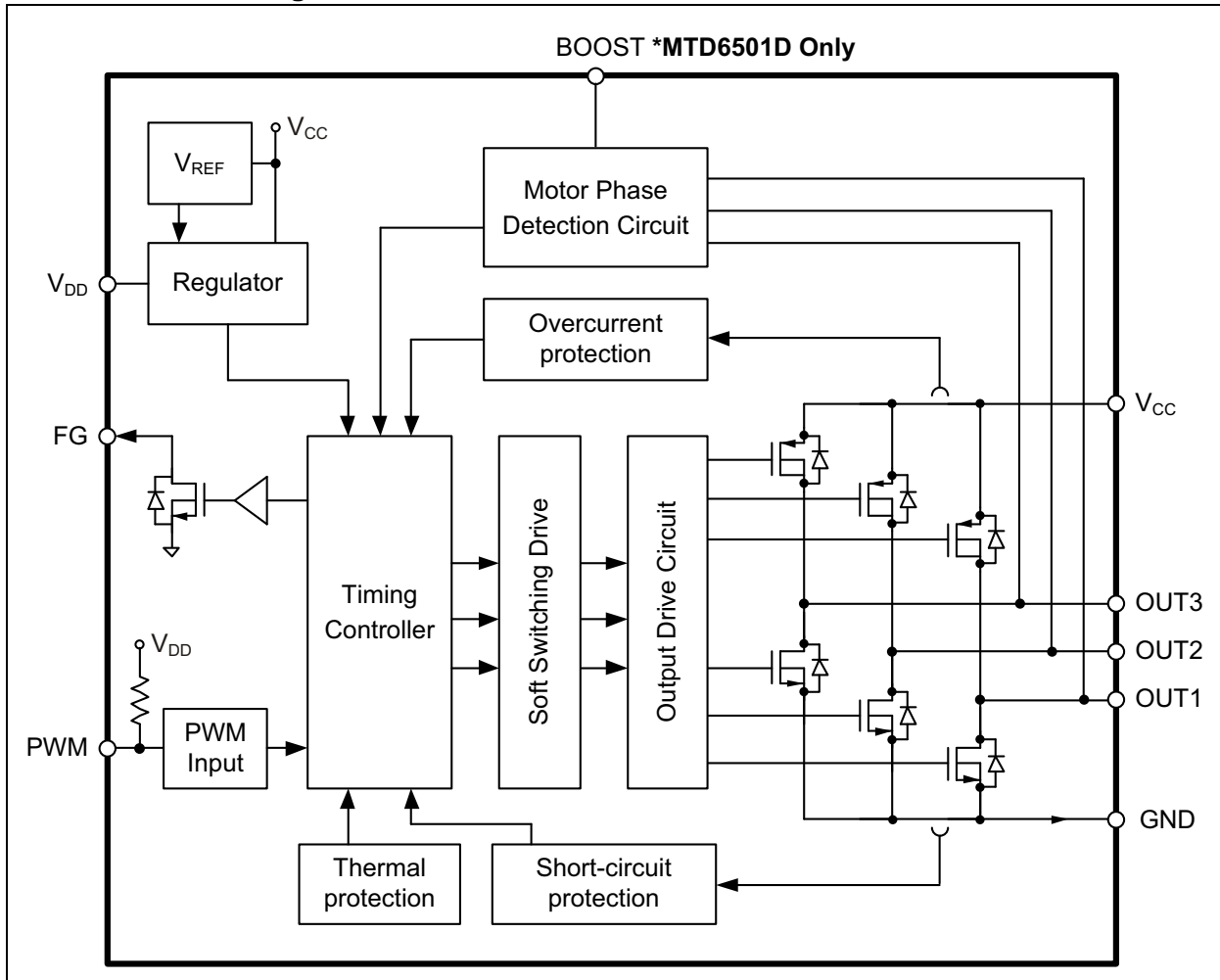

## Typical Application – Fan Motor Driver Using the MTD6501C or MTD6501G

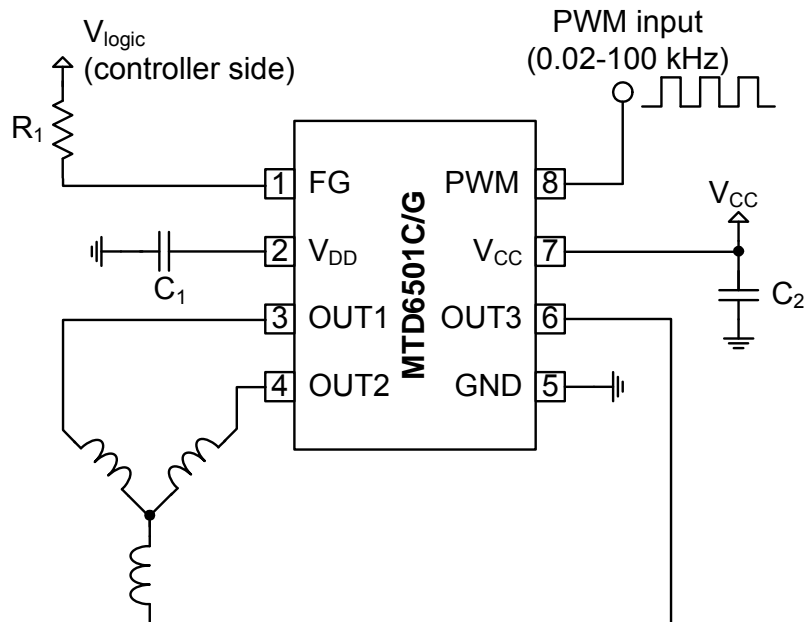

### Recommended External Components for Typical Application

Element	Type/Value	Comment
$C_1$	$\geq 1 \mu\text{F}$	Connect as close as possible to IC input pins
$C_2$	$\geq 1 \mu\text{F}$	Connect as close as possible to IC input pins
$R_1$	$\geq 10 \text{ k}\Omega$	Connect to $V_{logic}$ on controller side

# MTD6501C/D/G

## Typical Application – Fan Motor Driver Using the MTD6501D

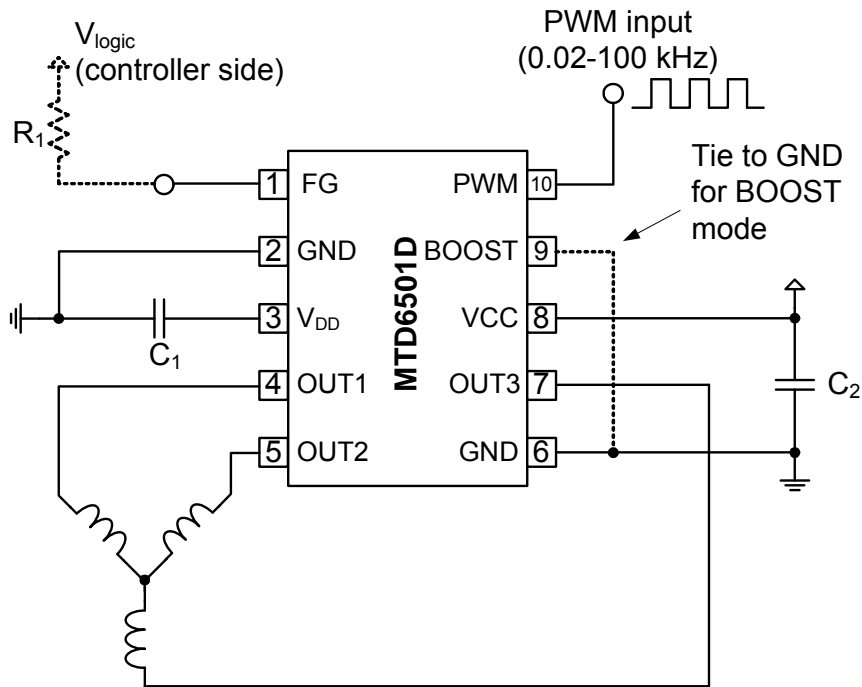

**Recommended External Components for Typical Application**

Element	Type/Value	Comment
C1	$\geq 1 \mu\text{F}$	Connect as close as possible to IC input pins
C2	$\geq 1 \mu\text{F}$	Connect as close as possible to IC input pins
R1	$\geq 10 \text{ k}\Omega$	Connect to Vlogic on controller side

## 1.0 ELECTRICAL CHARACTERISTICS

### Absolute Maximum Ratings†

Power Supply Voltage ( $V_{CC\_MAX}$ )	-0.7 to +15.3V
Maximum OUT1, 2, 3 Output Voltage ( $V_{OUT\_MAX}$ )	-0.7 to +15.3V+0.7V
FG Maximum Output Voltage ( $V_{FG\_MAX}$ )	-0.7 to +15.3V
Maximum Output Current <sup>(3,4)</sup> ( $I_{OUT\_MAX}$ )	800 mA
Maximum Output Current <sup>(3,5)</sup> ( $I_{OUT\_MAX}$ )	500 mA
FG Maximum Output Voltage ( $V_{FG\_MAX}$ )	-0.7 to +15.3V
FG Maximum Output Current ( $I_{FG\_MAX}$ )	5.0 mA
$V_{DD}$ Maximum Voltage ( $V_{DD\_MAX}$ )	-0.7 to +4.0V
PWM Maximum Voltage ( $V_{PWM\_MAX}$ )	-0.7 to +4.0V
Allowable Power Dissipation <sup>(1,2,4)</sup> ( $P_{D\_MAX}$ )	1.0W
Allowable Power Dissipation <sup>(1,2,5)</sup> ( $P_{D\_MAX}$ )	0.5W
Max Junction Temperature ( $T_J$ )	+150°C

† **Notice:** Stresses above those listed under “Maximum Ratings” may cause permanent damage to the device. This is a stress rating only and functional operation of the device at those or any other conditions above those indicated in the operational listings of this specification is not implied. Exposure to maximum rating conditions for extended periods may affect device reliability.

**Note 1:** Reference PCB, according to JEDEC standard EIA/JESD 51-9.

**2:** Derating applies for ambient temperatures outside the specified operating range (refer to [Figure 1-1](#)).

**3:** OUT1, OUT2, OUT3 (Continuous, 100% duty cycle).

**4:** MTD6501C and MTD6501G

**5:** MTD6501D

### ELECTRICAL CHARACTERISTICS

Electrical Specifications: Unless otherwise specified, all limits are established for $V_{CC} = 5.0V$ , $T_A = +25^\circ C$						
Parameters	Sym.	Min.	Typ.	Max.	Units	Conditions
Power Supply Voltage	$V_{CC}$	2	—	14	V	
Power Supply Current	$I_{VCC}$	—	10	—	mA	Rotation Mode
			5			Lock-Protection Mode
OUTx High Resistance	$R_{ON(H)}$	—	0.75	1	$\Omega$	$I_{OUT} = 0.5A$ , $V_{CC} = 3.3V$ to 14V
OUTx Low Resistance	$R_{ON(L)}$	—	0.75	1	$\Omega$	$I_{OUT} = -0.5A$ , $V_{CC} = 3.3V$ to 14V
OUTx Total Resistance	$R_{ON(H+L)}$	—	1.5	2	$\Omega$	$I_{OUT} = 0.5A$ , $V_{CC} = 3.3V$ to 14V
$V_{DD}$ Output Voltage	$V_{DD}$	—	3	—	V	$V_{CC} = 3.3V$ to 14V
			$V_{CC} - 0.2$		V	$V_{CC} < 3.3V$
PWM Input Frequency	$f_{PWM}$	0.02	—	100	kHz	—
PWM Input H Level	$V_{PWM\_H}$	$0.8 * V_{DD}$	—	3.6	V	—
PWM Input L Level	$V_{PWM\_L}$	0	—	$0.2 * V_{DD}$	V	—
PWM Internal Pull-Up Current	$I_{PWM\_L}$	17	34	—	$\mu A$	PWM = GND, $V_{CC} = 3.3V$ to 14V
			8		$\mu A$	PWM = GND, $V_{CC} < 3.3V$
PWM Output Frequency	$f_{PWM\_O}$	—	20	—	kHz	<b>MTD6501C and MTD6501D</b>
			23		kHz	<b>MTD6501G</b>
FG Output Pin Low Level Voltage	$V_{OL\_FG}$	—	—	0.25	V	$I_{FG} = -1$ mA
FG Output Pin Leakage Current	$I_{LH\_FG}$	—	—	10	$\mu A$	$V_{FG} = 14V$
Lock Protection Operating Time	$T_{RUN}$	—	0.5	—	s	—
Lock Protection Waiting Time	$T_{WAIT}$	4.5	5	5.5	s	—
Thermal Shutdown	$T_{SD}$	—	170	—	$^\circ C$	—
Thermal Shutdown Hysteresis	$T_{SD\_HYS}$	—	25	—	$^\circ C$	—

# MTD6501C/D/G

## TEMPERATURE SPECIFICATIONS

**Electrical Specifications:** Unless otherwise specified, all limits are established for  $V_{CC} = 5.0V$ ,  $T_A = +25^\circ C$

Parameters	Sym.	Min.	Typ.	Max.	Units	Conditions
<b>Temperature Ranges</b>						
Operating Temperature	$T_{OPR}$	-30	—	+95	$^\circ C$	
Storage Temperature Range	$T_{STG}$	-55	—	+150	$^\circ C$	

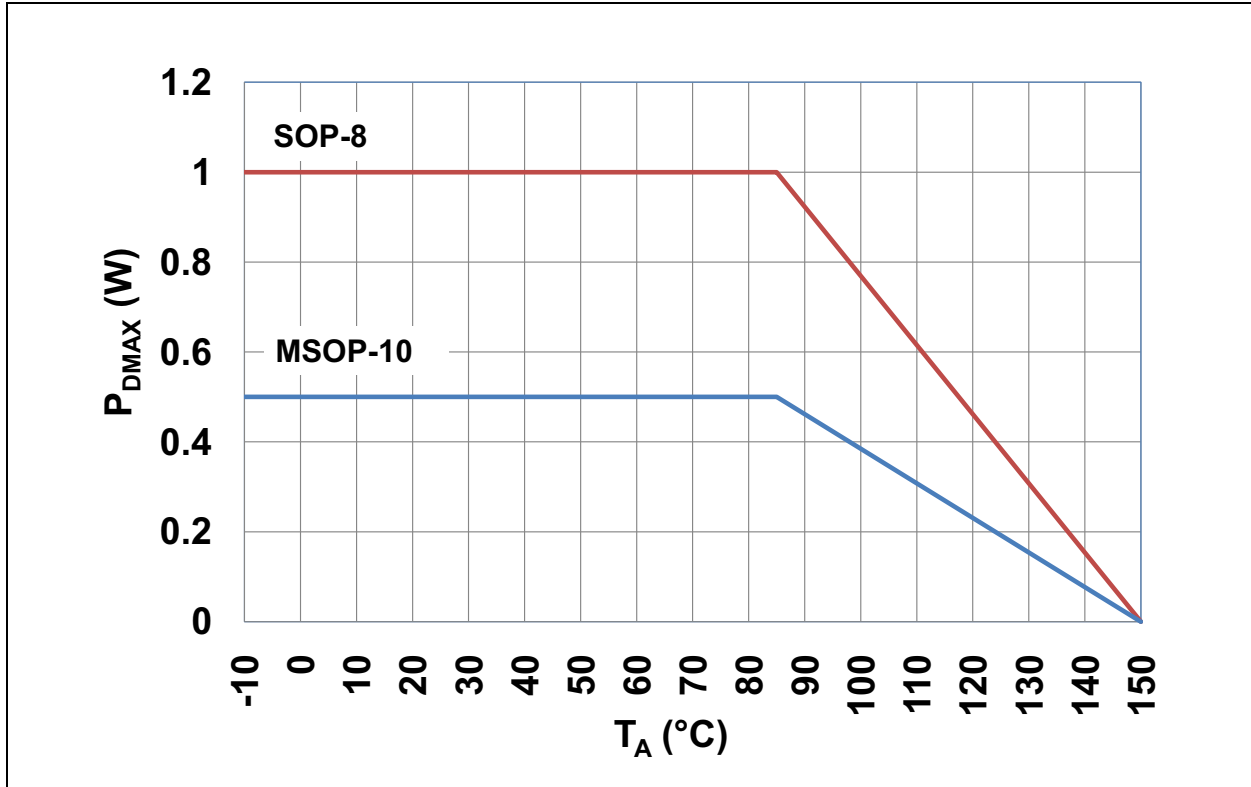

**FIGURE 1-1:** Allowable Power Dissipation ( $P_{D\_MAX}$ ) as a Function of Ambient Temperature ( $T_A$ ).

## 2.0 PIN DESCRIPTIONS

The descriptions of the pins are listed in [Table 2-1](#).

**TABLE 2-1: MTD6501C/D/G PIN FUNCTION TABLE**

MTD6501C, MTD6501G	MTD6501D	Type	Symbol	Description
	SOP-8			
1	1	O	FG	Motor speed indication output
2	3	P	$V_{DD}$	Internal regulator output (for decoupling only)
3	4	O	OUT1	Single-phase coil output pin
4	5	O	OUT2	Single-phase coil output pin
5	2, 6	P	GND	Negative voltage supply (ground)
6	7	O	OUT3	Single-phase coil output pin
7	8	P	$V_{CC}$	Positive voltage supply for motor driver
8	10	I	PWM	PWM input signal for speed control
N/A	9	I	BOOST	Boost mode selection: <ul style="list-style-type: none"> <li>• Pin floating for Normal mode</li> <li>• Pin tied to GND for Boost mode</li> </ul>

**Legend:** I = Input; O = Output; P = Power

# MTD6501C/D/G

---

NOTES:

## 3.0 FUNCTIONAL DESCRIPTION

The MTD6501C/D/G devices generate a full-wave signal to drive a 3-phase sensorless BLDC motor. High efficiency and low-power consumption are achieved due to DMOS transistors and synchronous rectification drive type. The current carrying order of the output is as follows: OUT1 → OUT2 → OUT3.

### 3.1 Speed Control

The rotational speed of the motor can be controlled either through the PWM digital input signal or by acting directly on the power supply ( $V_{CC}$ ). When the PWM signal is “High” (or left open) the motor rotates at full speed. When the PWM signal is “Low”, the motor is stopped (and the IC outputs are set to high-impedance). By changing the PWM duty cycle, the speed can be adjusted. Notice that the PWM frequency has no special meaning for the motor speed and is asynchronous with the activation of the output transistors. Thus, the user has maximum freedom to choose the PWM system frequency within a wide range (from 20 Hz to 100 kHz), while the output transistor activation always occurs at a fixed rate, which is outside of the range of audible frequencies. The MTD6501C and MTD6501D typical output frequency is 20 kHz. The MTD6501G output frequency is 23 kHz.

### 3.2 Frequency Generator Function

The Frequency Generator output is a “Hall-sensor equivalent” digital output, giving information to an external controller about the speed and phase of the motor. The FG pin is an open drain output, connecting to a logical voltage level through an external pull-up resistor. When a lock (or out-of-sync) situation is detected by the driver, this output is set to high-impedance until the motor is restarted. Leave the pin open when not used. The FG signal can be used to compute the motor speed in rotations per minute (RPM). Typically, for a four pole BLDC fan, the speed in RPMs is 30 FG frequency (Hz).

### 3.3 Lockup Protection and Automatic Restart

If the motor is stopped (blocked) or if it loses synchronization with the driver, a lock-up protection circuit detects this situation and disables the driver (by setting its outputs to high-impedance) in order to prevent the motor coil from burnout. After a “waiting time” ( $T_{WAIT}$ ), the lock-up protection is released and normal operation resumes for a given time ( $T_{RUN}$ ). In case the motor is still blocked, a new period of waiting time is started.  $T_{WAIT}$  and  $T_{RUN}$  timings are fixed internally, so that no external capacitor is needed.

### 3.4 Overcurrent Protection and Short Circuit Detection

The motor peak current is limited by the driver to a fixed value (defined internally), thus limiting the maximum power dissipation in the coils. The detection of a short-circuit situation immediately sets the driver outputs to high-impedance, in order to avoid permanent damage to the IC.

### 3.5 Thermal Shutdown

The MTD6501C/D/G have a thermal protection function which detects when the die temperature exceeds  $T_{SD} = +170^{\circ}\text{C}$ . When this temperature is reached, the circuit enters Thermal Shutdown mode and the outputs OUT1, OUT2 and OUT3 are disabled (high-impedance), avoiding IC destruction and allowing the circuit to cool down. Once the junction temperature ( $T_{SD}$ ) has dropped below  $+145^{\circ}\text{C}$ , the normal operation resumes (thermal detection circuit has  $+25^{\circ}\text{C}$  hysteresis function).

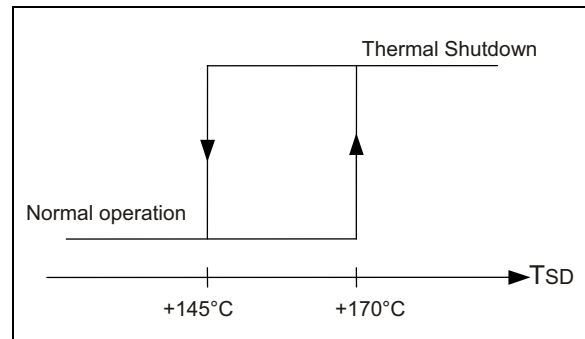

**FIGURE 3-1:** Thermal Protection Hysteresis.

### 3.6 Internal Voltage Regulator

$V_{DD}$  voltage is generated internally and is used to supply internal logical blocks. The  $V_{DD}$  pin is used to connect an external decoupling capacitor (1  $\mu\text{F}$  or higher). Notice that this pin is for IC internal use and is not designed to supply DC current to external blocks.

# MTD6501C/D/G

---

## 3.7 Boost Mode (MTD6501D)

The Boost mode is an optional BEMF pre-amplification by a factor of three. The intention of Boost mode is to compensate for motors with a low coupling coefficient (= BEMF coefficient), thus allowing it to cover an even wider range of motor characteristics. Notice that Boost mode impacts the mechanical performance of the motor altogether. In Boost mode, the speed of the motor will adjust faster to variations of the control ( $V_{CC}$  or PWM) and/or of the load, including at start-up. However, when the BEMF is amplified too much, the mechanical performance (in terms of vibration and acoustic noise) may start degrading. Thus, Boost mode may be inappropriate for motors that already have a good coupling coefficient. The optimum choice between normal mode and Boost mode depends both on the application requirements and on the motor characteristics.

Refer to [Table 3-1](#) for usage of Boost pin 9; leaving this pin floating results in the normal mode of operation, while tying this pin to GND activates Boost mode (active low feature, internal pull-up).

**TABLE 3-1: POSSIBLE MODES OF OPERATION BASED ON THE BOOST PIN CONNECTION**

<b>BOOST Pin</b>	<b>Mode of Operation</b>
Floating	Normal
Tied to GND	Boost

## 4.0 PACKAGING INFORMATION

### 4.1 Package Marking Information

8-Lead SOP (3.90 mm) (MTD6501C, MTD6501G)

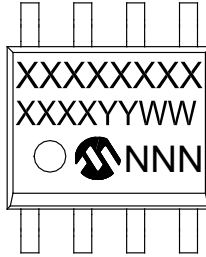

Example

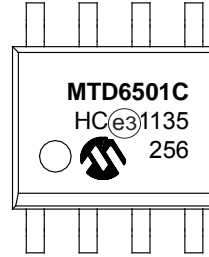

10-Lead MSOP (MTD6501D)

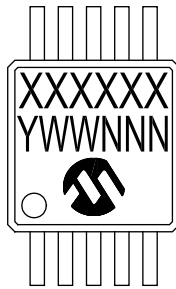

Example

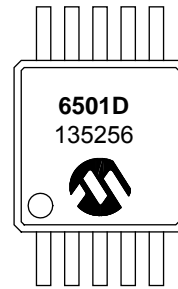

<b>Legend:</b>	XX...X	Customer-specific information
	Y	Year code (last digit of calendar year)
	YY	Year code (last 2 digits of calendar year)
	WW	Week code (week of January 1 is week '01')
	NNN	Alphanumeric traceability code
	(e3)	Pb-free JEDEC designator for Matte Tin (Sn)
	*	This package is Pb-free. The Pb-free JEDEC designator (e3) can be found on the outer packaging for this package.

**Note:** In the event the full Microchip part number cannot be marked on one line, it will be carried over to the next line, thus limiting the number of available characters for customer-specific information.



## 8-Lead Thermally Enhanced Plastic Small Outline (SE) - Narrow, 3.90 mm Body [SOP]

**Note:** For the most current package drawings, please see the Microchip Packaging Specification located at <http://www.microchip.com/packaging>

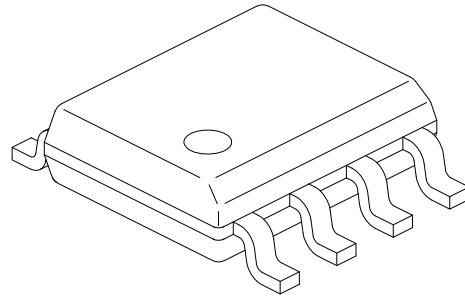
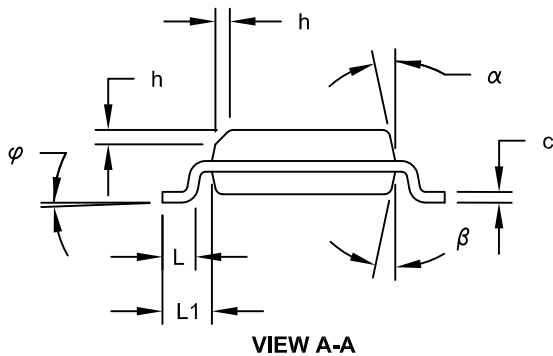

Dimension Limits	Units	MILLIMETERS		
		MIN	NOM	MAX
Number of Pins	N	8		
Pitch	e	1.27		
Overall Height	A	-	-	1.75
Molded Package Thickness	A2	1.25	-	-
Standoff §	A1	0.00	-	0.15
Overall Width	E	5.80	6.00	6.20
Molded Package Width	E1	3.80	3.90	4.00
Overall Length	D	4.70	4.90	5.10
Exposed Pad Width	E2	2.19	2.29	2.39
Exposed Pad Length	D2	2.19	2.29	2.39
Chamfer (Optional)	h	0.25	-	0.50
Foot Length	L	0.40	-	1.27
Footprint	L1	1.04	1.04	1.04
Foot Angle	φ	0°	-	8°
Lead Thickness	c	0.17	-	0.25
Lead Width	b	0.31	-	0.51
Mold Draft Angle Top	α	5°	-	15°
Mold Draft Angle Bottom	β	5°	-	15°

**Notes:**

- Pin 1 visual index feature may vary, but must be located within the hatched area.
- § Significant Characteristic
- Dimensions D and E1 do not include mold flash or protrusions. Mold flash or protrusions shall not exceed 0.15mm per side.
- Dimensioning and tolerancing per ASME Y14.5M

BSC: Basic Dimension. Theoretically exact value shown without tolerances.

REF: Reference Dimension, usually without tolerance, for information purposes only.

Microchip Technology Drawing No. C04-121A Sheet 2 of 2

# MTD6501C/D/G

## 8-Lead Thermally Enhanced Plastic Small Outline (SE) - Narrow, 3.90 mm Body [SOP]

**Note:** For the most current package drawings, please see the Microchip Packaging Specification located at <http://www.microchip.com/packaging>

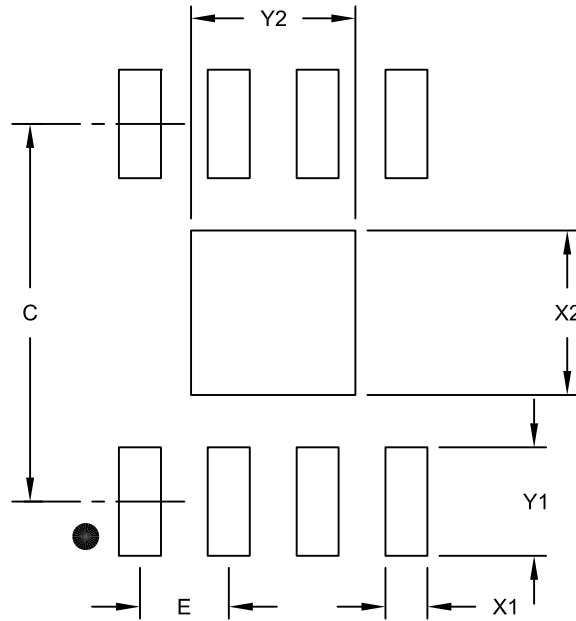

RECOMMENDED LAND PATTERN

Dimension Limits	Units	MILLIMETERS		
		MIN	NOM	MAX
Contact Pitch	E	1.27 BSC		
Contact Pad Spacing	C		5.40	
Contact Pad Width (X8)	X1			0.60
Contact Pad Length (X8)	Y1			1.55
Exposed Pad Width	X2			2.35
Exposed Pad Length	Y2			2.35

**Notes:**

1. Dimensioning and tolerancing per ASME Y14.5M

BSC: Basic Dimension. Theoretically exact value shown without tolerances.

Microchip Technology Drawing No. C04-2121A

## 10-Lead Plastic Micro Small Outline Package (MS) [MSOP]

**Note:** For the most current package drawings, please see the Microchip Packaging Specification located at <http://www.microchip.com/packaging>

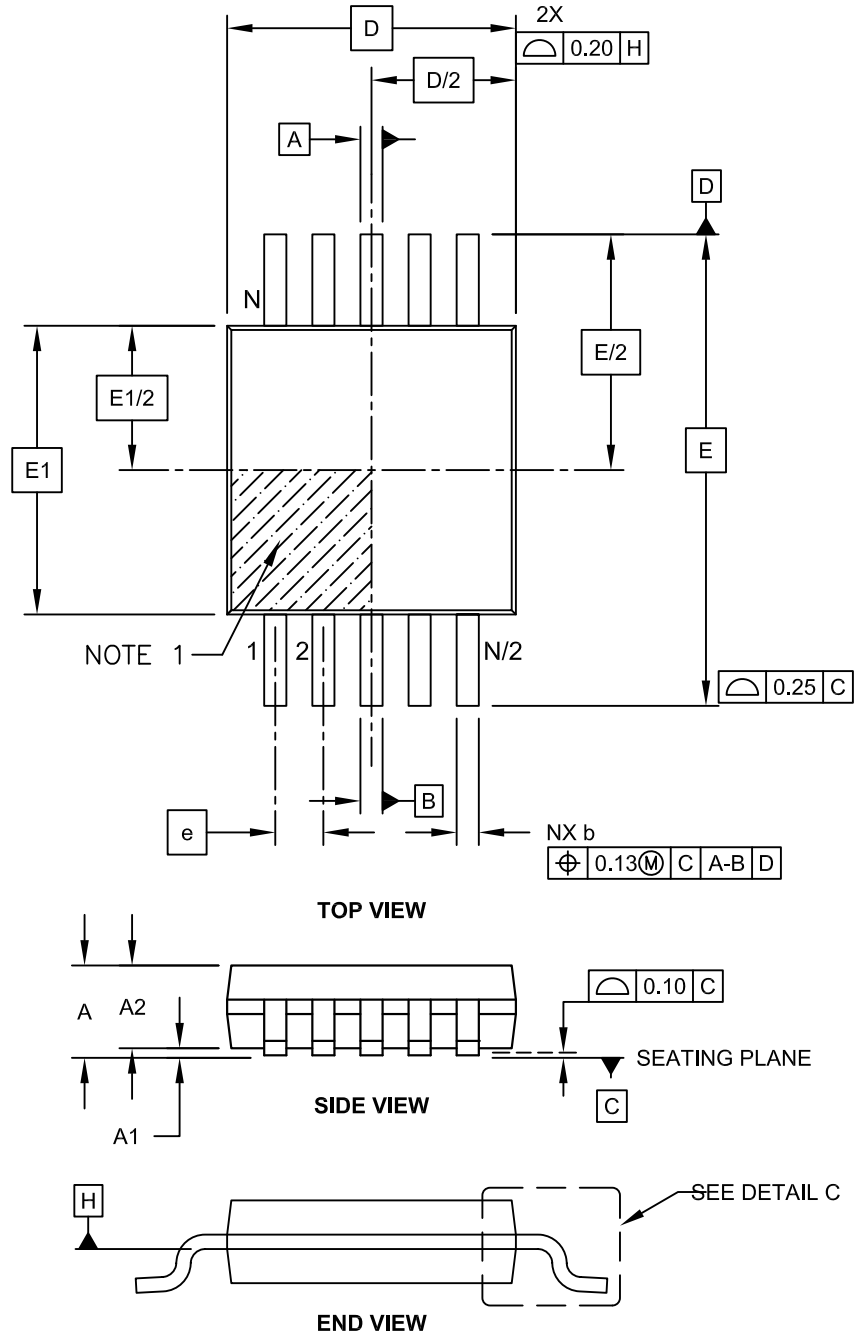

Microchip Technology Drawing C04-021C Sheet 1 of 2

# MTD6501C/D/G

## 10-Lead Plastic Micro Small Outline Package (MS) [MSOP]

**Note:** For the most current package drawings, please see the Microchip Packaging Specification located at <http://www.microchip.com/packageing>

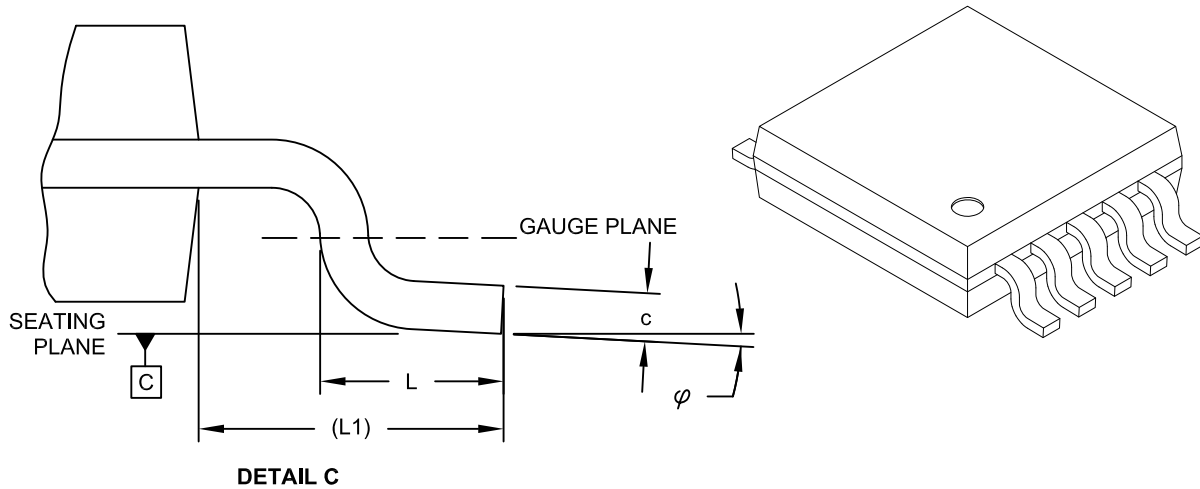

Dimension Limits	Units	MILLIMETERS		
		MIN	NOM	MAX
Number of Pins	N	10		
Pitch	e	0.50 BSC		
Overall Height	A	-	-	1.10
Molded Package Thickness	A2	0.75	0.85	0.95
Standoff	A1	0.00	-	0.15
Overall Width	E	4.90 BSC		
Molded Package Width	E1	3.00 BSC		
Overall Length	D	3.00 BSC		
Foot Length	L	0.40	0.60	0.80
Footprint	L1	0.95 REF		
Foot Angle	φ	0°	-	8°
Lead Thickness	c	0.08	-	0.23
Lead Width	b	0.15	-	0.33

**Notes:**

- Pin 1 visual index feature may vary, but must be located within the hatched area.
- Dimensions D and E1 do not include mold flash or protrusions. Mold flash or protrusions shall not exceed 0.15mm per side.
- Dimensioning and tolerancing per ASME Y14.5M.  
 BSC: Basic Dimension. Theoretically exact value shown without tolerances.  
 REF: Reference Dimension, usually without tolerance, for information purposes only.

Microchip Technology Drawing C04-021C Sheet 2 of 2

## 10-Lead Plastic Micro Small Outline Package (MS) [MSOP]

**Note:** For the most current package drawings, please see the Microchip Packaging Specification located at <http://www.microchip.com/packaging>

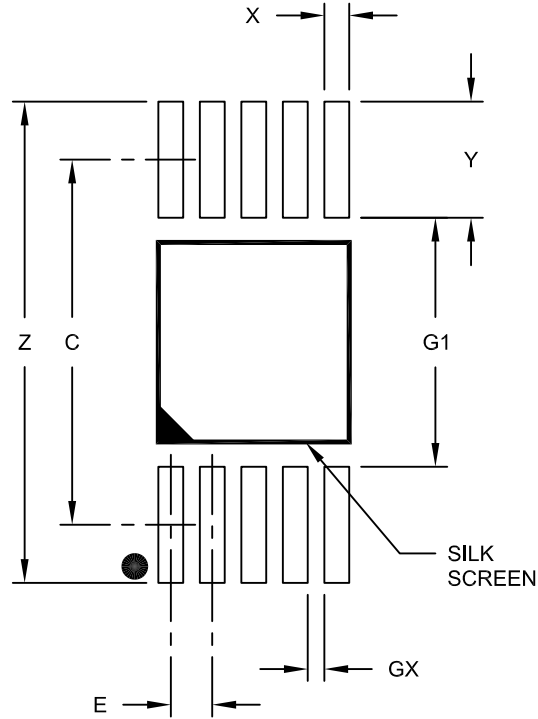

RECOMMENDED LAND PATTERN

Dimension Limits	Units	MILLIMETERS		
		MIN	NOM	MAX
Contact Pitch	E	0.50 BSC		
Contact Pad Spacing	C		4.40	
Overall Width	Z			5.80
Contact Pad Width (X10)	X1			0.30
Contact Pad Length (X10)	Y1			1.40
Distance Between Pads	G1	3.00		
Distance Between Pads	GX	0.20		

**Notes:**

1. Dimensioning and tolerancing per ASME Y14.5M

BSC: Basic Dimension. Theoretically exact value shown without tolerances.

Microchip Technology Drawing No. C04-2021A

# MTD6501C/D/G

---

NOTES:

## APPENDIX A: REVISION HISTORY

### Revision B (May 2012)

The following is the list of modifications:

1. Added the MTD6501G device to the family and related information throughout the document.
2. Updated the **Temperature Specifications** table.
3. Sorted the information in **Table 2-1**.
4. Corrected Frequency Generator output to open drain in **Section 3.2 “Frequency Generator Function”**.
5. Renamed **Section 4.0 “Packaging Information”**. Added **Section 4.1 “Package Marking Information”**.
6. Added **Product Identification System** section.
7. Other minor typographical corrections.

### Revision A (September 2010)

- Original data sheet for the MTD6501C/D/G family of devices.

# MTD6501C/D/G

---

NOTES:

## PRODUCT IDENTIFICATION SYSTEM

To order or obtain information, e.g., on pricing or delivery, refer to the factory or the listed sales office.

<u>PART NO.</u>		<u>-X</u>	<u>XX</u>	<b>Examples:</b>
<b>Device</b>	<b>Tube/Tape and Reel</b>	<b>Package</b>		
Device	MTD6501C-H:	3-Phase BLDC Sinusoidal Sensorless Fan Motor Driver (I <sub>OUT</sub> maximum 800 mA, PWM 20 kHz) (Tube)		a) MTD6501C-HC1 Tube, 8LD SOP Package
	MTD6501C-L:	3-Phase BLDC Sinusoidal Sensorless Fan Motor Driver (I <sub>OUT</sub> maximum 800 mA, PWM 20 kHz) (Tape and Reel)		b) MTD6501C-LC1 Tape and Reel, 8LD SOP Package
	MTD6501D-H:	3-Phase BLDC Sinusoidal Sensorless Fan Motor Driver (I <sub>OUT</sub> maximum 500 mA, PWM 20 kHz, Boost option) (Tube)		c) MTD6501D-HC1 Tube, 10LD MSOP Package
	MTD6501D-L:	3-Phase BLDC Sinusoidal Sensorless Fan Motor Driver (I <sub>OUT</sub> maximum 500 mA, PWM 20 kHz, Boost option) (Tape and Reel)		d) MTD6501D-LC1 Tape and Reel, 10LD MSOP Package
	MTD6501G-H:	3-Phase BLDC Sinusoidal Sensorless Fan Motor Driver (I <sub>OUT</sub> maximum 800 mA, PWM 23 kHz) (Tube)		e) MTD6501G-HC1 Tube, 8LD SOP Package
	MTD6501G-L:	3-Phase BLDC Sinusoidal Sensorless Fan Motor Driver (I <sub>OUT</sub> maximum 800 mA, PWM 23 kHz) (Tape and Reel)		f) MTD6501G-LC1 Tape and Reel, 8LD SOP Package
Package	C1*	=	8-Lead Plastic Small Outline – Thermally Enhanced Package (SOP)	
		=	10-Lead Plastic Micro Small Outline Package (MSOP)	
			* These devices are formerly products of Advanced Silicon	

# MTD6501C/D/G

---

NOTES:

---

**Note the following details of the code protection feature on Microchip devices:**

- Microchip products meet the specification contained in their particular Microchip Data Sheet.
- Microchip believes that its family of products is one of the most secure families of its kind on the market today, when used in the intended manner and under normal conditions.
- There are dishonest and possibly illegal methods used to breach the code protection feature. All of these methods, to our knowledge, require using the Microchip products in a manner outside the operating specifications contained in Microchip's Data Sheets. Most likely, the person doing so is engaged in theft of intellectual property.
- Microchip is willing to work with the customer who is concerned about the integrity of their code.
- Neither Microchip nor any other semiconductor manufacturer can guarantee the security of their code. Code protection does not mean that we are guaranteeing the product as “unbreakable.”

Code protection is constantly evolving. We at Microchip are committed to continuously improving the code protection features of our products. Attempts to break Microchip's code protection feature may be a violation of the Digital Millennium Copyright Act. If such acts allow unauthorized access to your software or other copyrighted work, you may have a right to sue for relief under that Act.

---

Information contained in this publication regarding device applications and the like is provided only for your convenience and may be superseded by updates. It is your responsibility to ensure that your application meets with your specifications. MICROCHIP MAKES NO REPRESENTATIONS OR WARRANTIES OF ANY KIND WHETHER EXPRESS OR IMPLIED, WRITTEN OR ORAL, STATUTORY OR OTHERWISE, RELATED TO THE INFORMATION, INCLUDING BUT NOT LIMITED TO ITS CONDITION, QUALITY, PERFORMANCE, MERCHANTABILITY OR FITNESS FOR PURPOSE. Microchip disclaims all liability arising from this information and its use. Use of Microchip devices in life support and/or safety applications is entirely at the buyer's risk, and the buyer agrees to defend, indemnify and hold harmless Microchip from any and all damages, claims, suits, or expenses resulting from such use. No licenses are conveyed, implicitly or otherwise, under any Microchip intellectual property rights.

**Trademarks**

The Microchip name and logo, the Microchip logo, dsPIC, KEELOQ, KEELOQ logo, MPLAB, PIC, PICmicro, PICSTART, PIC<sup>32</sup> logo, rPIC and UNI/O are registered trademarks of Microchip Technology Incorporated in the U.S.A. and other countries.

FilterLab, Hampshire, HI-TECH C, Linear Active Thermistor, MXDEV, MXLAB, SEEVAL and The Embedded Control Solutions Company are registered trademarks of Microchip Technology Incorporated in the U.S.A.

Analog-for-the-Digital Age, Application Maestro, chipKIT, chipKIT logo, CodeGuard, dsPICDEM, dsPICDEM.net, dsPICworks, dsSPEAK, ECAN, ECONOMONITOR, FanSense, HI-TIDE, In-Circuit Serial Programming, ICSP, Mindi, MiWi, MPASM, MPLAB Certified logo, MPLIB, MPLINK, mTouch, Omniscient Code Generation, PICC, PICC-18, PICDEM, PICDEM.net, PICKit, PICtail, REAL ICE, rLAB, Select Mode, Total Endurance, TSHARC, UniWinDriver, WiperLock and ZENA are trademarks of Microchip Technology Incorporated in the U.S.A. and other countries.

SQTP is a service mark of Microchip Technology Incorporated in the U.S.A.

All other trademarks mentioned herein are property of their respective companies.

© 2010-2012, Microchip Technology Incorporated, Printed in the U.S.A., All Rights Reserved.

 Printed on recycled paper.

ISBN: 978-1-62076-278-3

*Microchip received ISO/TS-16949:2009 certification for its worldwide headquarters, design and wafer fabrication facilities in Chandler and Tempe, Arizona; Gresham, Oregon and design centers in California and India. The Company's quality system processes and procedures are for its PIC<sup>®</sup> MCUs and dsPIC<sup>®</sup> DSCs, KEELOQ<sup>®</sup> code hopping devices, Serial EEPROMs, microperipherals, nonvolatile memory and analog products. In addition, Microchip's quality system for the design and manufacture of development systems is ISO 9001:2000 certified.*

---

**QUALITY MANAGEMENT SYSTEM**  
**CERTIFIED BY DNV**  
**== ISO/TS 16949 ==**



# MICROCHIP

## Worldwide Sales and Service

### AMERICAS

**Corporate Office**  
2355 West Chandler Blvd.  
Chandler, AZ 85224-6199  
Tel: 480-792-7200  
Fax: 480-792-7277  
Technical Support:  
<http://www.microchip.com/support>  
Web Address:  
[www.microchip.com](http://www.microchip.com)

**Atlanta**  
Duluth, GA  
Tel: 678-957-9614  
Fax: 678-957-1455

**Boston**  
Westborough, MA  
Tel: 774-760-0087  
Fax: 774-760-0088

**Chicago**  
Itasca, IL  
Tel: 630-285-0071  
Fax: 630-285-0075

**Cleveland**  
Independence, OH  
Tel: 216-447-0464  
Fax: 216-447-0643

**Dallas**  
Addison, TX  
Tel: 972-818-7423  
Fax: 972-818-2924

**Detroit**  
Farmington Hills, MI  
Tel: 248-538-2250  
Fax: 248-538-2260

**Indianapolis**  
Noblesville, IN  
Tel: 317-773-8323  
Fax: 317-773-5453

**Los Angeles**  
Mission Viejo, CA  
Tel: 949-462-9523  
Fax: 949-462-9608

**Santa Clara**  
Santa Clara, CA  
Tel: 408-961-6444  
Fax: 408-961-6445

**Toronto**  
Mississauga, Ontario,  
Canada  
Tel: 905-673-0699  
Fax: 905-673-6509

### ASIA/PACIFIC

**Asia Pacific Office**  
Suites 3707-14, 37th Floor  
Tower 6, The Gateway  
Harbour City, Kowloon  
Hong Kong  
Tel: 852-2401-1200  
Fax: 852-2401-3431

**Australia - Sydney**  
Tel: 61-2-9868-6733  
Fax: 61-2-9868-6755

**China - Beijing**  
Tel: 86-10-8569-7000  
Fax: 86-10-8528-2104

**China - Chengdu**  
Tel: 86-28-8665-5511  
Fax: 86-28-8665-7889

**China - Chongqing**  
Tel: 86-23-8980-9588  
Fax: 86-23-8980-9500

**China - Hangzhou**  
Tel: 86-571-2819-3187  
Fax: 86-571-2819-3189

**China - Hong Kong SAR**  
Tel: 852-2401-1200  
Fax: 852-2401-3431

**China - Nanjing**  
Tel: 86-25-8473-2460  
Fax: 86-25-8473-2470

**China - Qingdao**  
Tel: 86-532-8502-7355  
Fax: 86-532-8502-7205

**China - Shanghai**  
Tel: 86-21-5407-5533  
Fax: 86-21-5407-5066

**China - Shenyang**  
Tel: 86-24-2334-2829  
Fax: 86-24-2334-2393

**China - Shenzhen**  
Tel: 86-755-8203-2660  
Fax: 86-755-8203-1760

**China - Wuhan**  
Tel: 86-27-5980-5300  
Fax: 86-27-5980-5118

**China - Xian**  
Tel: 86-29-8833-7252  
Fax: 86-29-8833-7256

**China - Xiamen**  
Tel: 86-592-2388138  
Fax: 86-592-2388130

**China - Zhuhai**  
Tel: 86-756-3210040  
Fax: 86-756-3210049

### ASIA/PACIFIC

**India - Bangalore**  
Tel: 91-80-3090-4444  
Fax: 91-80-3090-4123

**India - New Delhi**  
Tel: 91-11-4160-8631  
Fax: 91-11-4160-8632

**India - Pune**  
Tel: 91-20-2566-1512  
Fax: 91-20-2566-1513

**Japan - Osaka**  
Tel: 81-66-152-7160  
Fax: 81-66-152-9310

**Japan - Yokohama**  
Tel: 81-45-471-6166  
Fax: 81-45-471-6122

**Korea - Daegu**  
Tel: 82-53-744-4301  
Fax: 82-53-744-4302

**Korea - Seoul**  
Tel: 82-2-554-7200  
Fax: 82-2-558-5932 or  
82-2-558-5934

**Malaysia - Kuala Lumpur**  
Tel: 60-3-6201-9857  
Fax: 60-3-6201-9859

**Malaysia - Penang**  
Tel: 60-4-227-8870  
Fax: 60-4-227-4068

**Philippines - Manila**  
Tel: 63-2-634-9065  
Fax: 63-2-634-9069

**Singapore**  
Tel: 65-6334-8870  
Fax: 65-6334-8850

**Taiwan - Hsin Chu**  
Tel: 886-3-5778-366  
Fax: 886-3-5770-955

**Taiwan - Kaohsiung**  
Tel: 886-7-536-4818  
Fax: 886-7-330-9305

**Taiwan - Taipei**  
Tel: 886-2-2500-6610  
Fax: 886-2-2508-0102

**Thailand - Bangkok**  
Tel: 66-2-694-1351  
Fax: 66-2-694-1350

### EUROPE

**Austria - Wels**  
Tel: 43-7242-2244-39  
Fax: 43-7242-2244-393

**Denmark - Copenhagen**  
Tel: 45-4450-2828  
Fax: 45-4485-2829

**France - Paris**  
Tel: 33-1-69-53-63-20  
Fax: 33-1-69-30-90-79

**Germany - Munich**  
Tel: 49-89-627-144-0  
Fax: 49-89-627-144-44

**Italy - Milan**  
Tel: 39-0331-742611  
Fax: 39-0331-466781

**Netherlands - Drunen**  
Tel: 31-416-690399  
Fax: 31-416-690340

**Spain - Madrid**  
Tel: 34-91-708-08-90  
Fax: 34-91-708-08-91

**UK - Wokingham**  
Tel: 44-118-921-5869  
Fax: 44-118-921-5820

11/29/11

## Looking for pricing, stock, or lifecycle information?

Click below to explore more details on WIN SOURCE:

 [View MTD6501C-HC1 on WIN SOURCE](#)

 [Microchip Technology](#) Information

## Optimize Your Supply Chain with WIN SOURCE Solutions

-  Global Sourcing Solution
-  Obsolete Management
-  Cost Control Management
-  Shortage Management
-  Alternative Solution
-  Excess Inventory Management