



THE DATASHEET OF FAN7392M



High-Current, High- & Low-Side, Gate-Drive IC



FAN7392

Description

The FAN7392 is a monolithic high- and low-side gate drive IC, that can drive high-speed MOSFETs and IGBTs that operate up to +600 V. It has a buffered output stage with all NMOS transistors designed for high pulse current driving capability and minimum cross-conduction. ON Semiconductor's high-voltage process and common-mode noise canceling techniques provide stable operation of the high-side driver under high dv/dt noise circumstances. An advanced level-shift circuit offers high-side gate driver operation up to $V_S = -9.8$ V (typical) for $V_{BS} = 15$ V. Logic inputs are compatible with standard CMOS or LSTTL output, down to 3.3 V logic. The UVLO circuit prevents malfunction when V_{CC} and V_{BS} are lower than the specified threshold voltage. The high-current and low-output voltage drop feature makes this device suitable for half- and full-bridge inverters, like switching-mode power supply and high-power DC-DC converter applications.

Features

- Floating Channel for Bootstrap Operation to +600 V
- 3 A/3 A Sourcing/Sinking Current Driving Capability
- Common-Mode dv/dt Noise Canceling Circuit
- 3.3 V Logic Compatible
- Separate Logic Supply (V_{DD}) Range from 3.3 V to 20 V
- Under-Voltage Lockout for V_{CC} and V_{BS}
- Cycle-by-Cycle Edge-Triggered Shutdown Logic
- Matched Propagation Delay for Both Channels
- Outputs In-phase with Input Signals
- Available in 14-DIP and 16-SOP (Wide) Packages
- This is a Pb-Free Device

Applications

- High-Speed Power MOSFET and IGBT Gate Driver
- Server Power Supply
- Uninterrupted Power Supply (UPS)
- Telecom System Power Supply
- Distributed Power Supply
- Motor Drive Inverter

ON Semiconductor®

www.onsemi.com

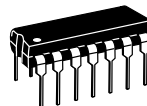

PDIP-14
14-PDIP
CASE 646-06

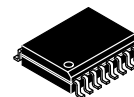

SOIC-16
16-SOP
CASE 751BH-01

MARKING DIAGRAM

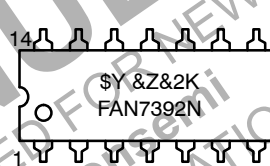

FAN7392N

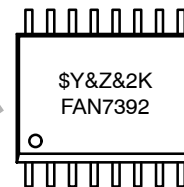

FAN7392MX

FAN7392N = Device Code
FAN7392
&Z = Assembly Plant Code
&2 = 2-Digit Date Code
&K = 2-Digits Lot Run Traceability Code

ORDERING INFORMATION

See detailed ordering and shipping information on page 15 of this data sheet.

TYPICAL APPLICATION DIAGRAMS

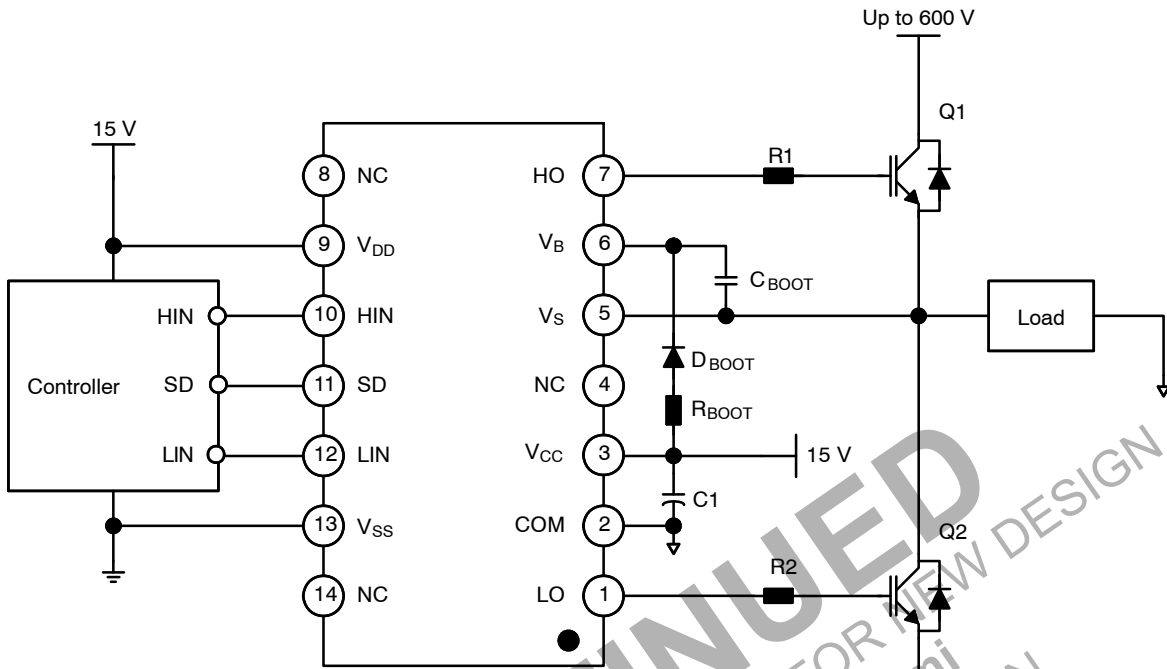

Figure 1. Typical Application Circuit (Referenced 14-DIP)

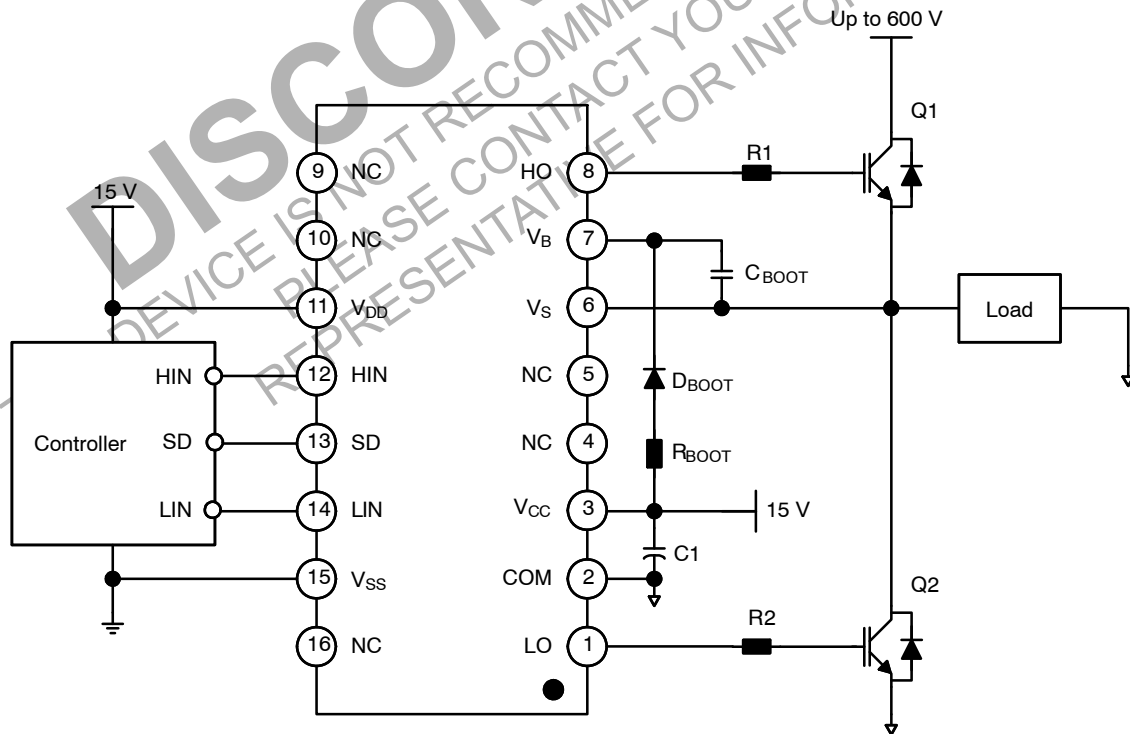

Figure 2. Application Circuit for Half-Bridge (Referenced 16-SOP)

FAN7392

INTERNAL BLOCK DIAGRAM

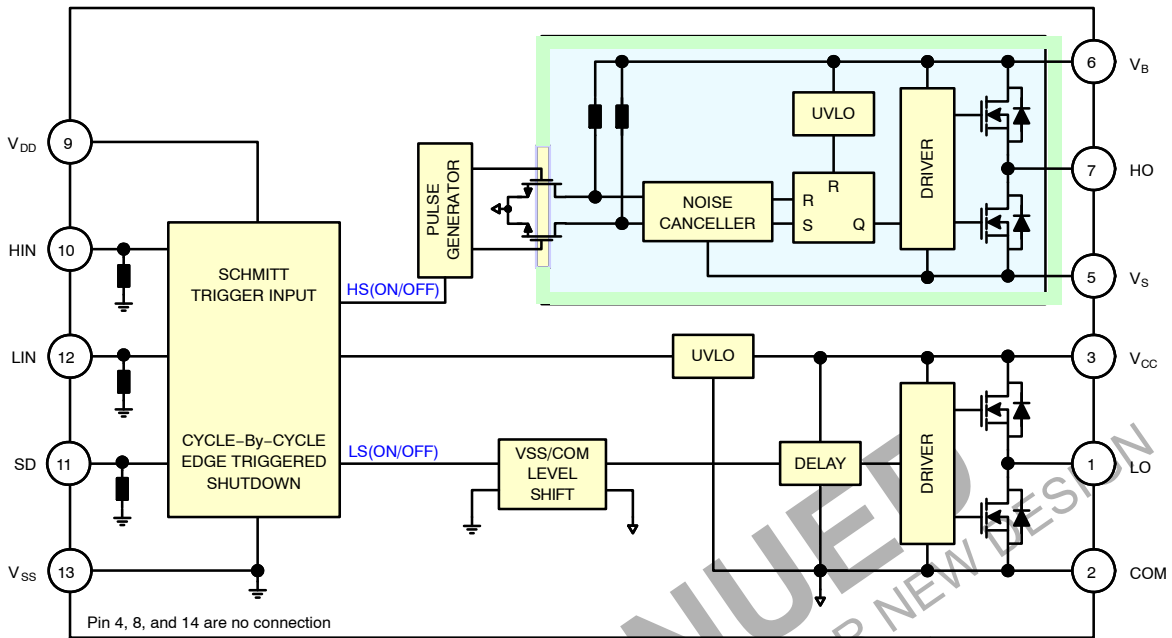

Figure 3. Functional Block Diagram (Referenced 14-Pin)

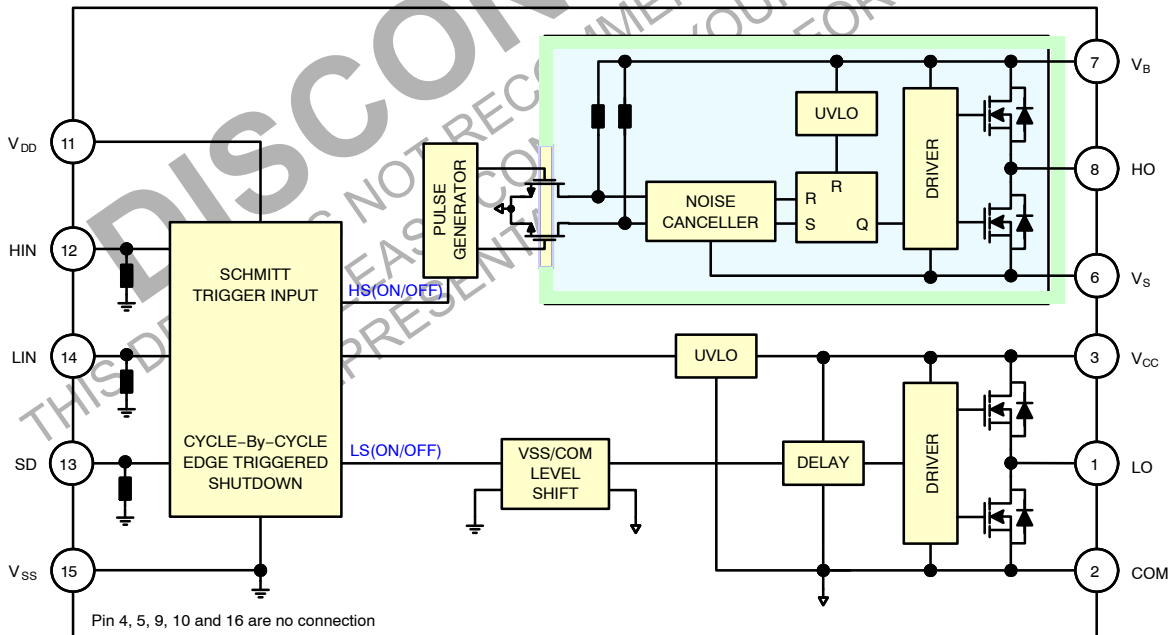

Figure 4. Functional Block Diagram (Referenced 16-SOP)

FAN7392

PIN CONFIGURATION

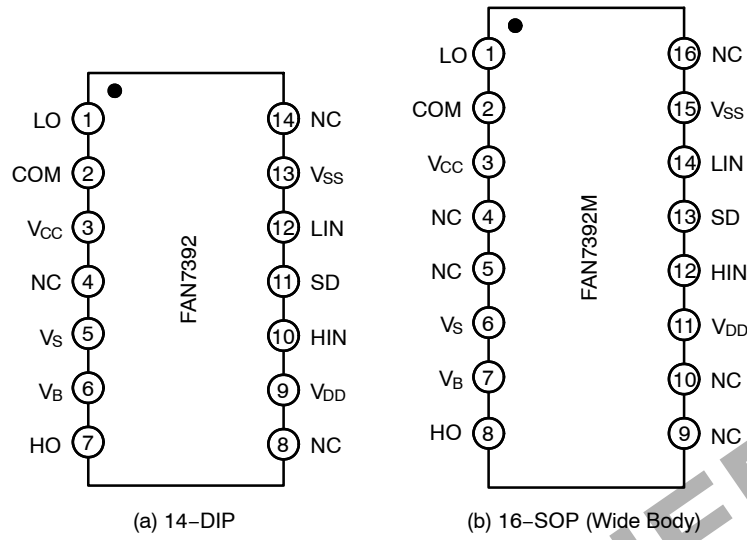

Figure 5. Pin Configurations (Top View)

PIN DEFINITIONS

14-Pin	16-Pin	Name	Description
1	1	LO	Low-Side Driver Output
2	2	COM	Low-Side Return
3	3	V _{CC}	Low-Side Supply Voltage
5	6	V _S	High-Voltage Floating Supply Return
6	7	V _B	High-Side Floating Supply
7	8	HO	High-Side Driver Output
9	11	V _{DD}	Logic Supply Voltage
10	12	HIN	Logic Input for High-Side Gate Driver Output
11	13	SD	Logic Input for Shutdown Function
12	14	LIN	Logic Input for Low-Side Gate Driver Output
13	15	V _{SS}	Logic Ground
4, 8, 14	4, 5, 9, 10, 16	NC	No Connect

FAN7392

ABSOLUTE MAXIMUM RATINGS (T_A = 25°C, unless otherwise noted)

Symbol	Characteristics	Min	Max	Unit	
V _B	High-Side Floating Supply Voltage	-0.3	625.0	V	
V _S	High-Side Floating Offset Voltage	V _B - 25.0	V _B + 0.3	V	
V _{HO}	High-Side Floating Output Voltage	V _S - 0.3	V _B + 0.3	V	
V _{CC}	Low-Side Supply Voltage	-0.3	25.0	V	
V _{LO}	Low-Side Floating Output Voltage	-0.3	V _{CC} + 0.3	V	
V _{DD}	Logic Supply Voltage	-0.3	V _{SS} + 25.0	V	
V _{SS}	Logic Supply Offset Voltage	V _{CC} - 25.0	V _{CC} + 0.3	V	
V _{IN}	Logic Input Voltage (HIN, LIN and SD)	V _{SS} - 0.3	V _{DD} + 0.3	V	
dV _S /dt	Allowable Offset Voltage Slew Rate	-	±50	V/ns	
P _D	Power Dissipation (Note 1, 2, 3)	14-PDIP	-	1.6	W
		16-SOP	-	1.3	
θ _{JA}	Thermal Resistance	14-PDIP	-	75	°C/W
		16-SOP	-	95	
T _J	Maximum Junction Temperature	-	+150	°C	
T _{STG}	Storage Temperature	-55	+150	°C	

Stresses exceeding those listed in the Maximum Ratings table may damage the device. If any of these limits are exceeded, device functionality should not be assumed, damage may occur and reliability may be affected.

1. Mounted on 76.2 x 114.3 x 1.6 mm PCB (FR-4 glass epoxy material).

2. Refer to the following standards:

JESD51-2: Integral circuits thermal test method environmental conditions - natural convection; and

JESD51-3: Low effective thermal conductivity test board for leaded surface-mount packages.

3. Do not exceed power dissipation (P_D) under any circumstances.

RECOMMENDED OPERATING CONDITIONS

Symbol	Parameter	Min	Max	Unit
V _B	High-Side Floating Supply Voltage	V _S + 10	V _S + 20	V
V _S	High-Side Floating Supply Offset Voltage	6 - V _{CC}	600	V
V _{HO}	High-Side Output Voltage	V _S	V _B	V
V _{CC}	Low-Side Supply Voltage	10	20	V
V _{LO}	Low-Side Output Voltage	0	V _{CC}	V
V _{DD}	Logic Supply Voltage	V _{SS} + 3	V _{SS} + 20	V
V _{SS}	Logic Supply Offset Voltage	-5	5	V
V _{IN}	Logic Input Voltage	V _{SS}	V _{DD}	V
T _A	Operating Ambient Temperature	-40	+125	°C

Functional operation above the stresses listed in the Recommended Operating Ranges is not implied. Extended exposure to stresses beyond the Recommended Operating Ranges limits may affect device reliability.

FAN7392

ELECTRICAL CHARACTERISTICS (V_{BIAS} (V_{CC} , V_{BS} , V_{DD}) = 15.0 V, V_{SS} = COM = 0 V and $T_A=25^\circ\text{C}$, unless otherwise specified. The V_{IH} , V_{IL} , and I_{IN} parameters are referenced to V_{SS} and are applicable to the respective input leads: HIN, LIN, and SD. The V_O and I_O parameters are referenced to V_S and COM and are applicable to the respective output leads: HO and LO.)

Symbol	Characteristics	Test Condition	Min	Typ	Max	Unit
--------	-----------------	----------------	-----	-----	-----	------

LOW-SIDE POWER SUPPLY SECTION

I_{QCC}	Quiescent V_{CC} Supply Current	$V_{IN} = 0\text{ V or }V_{DD}$	-	40	80	μA
I_{QDD}	Quiescent V_{DD} Supply Current	$V_{IN} = 0\text{ V or }V_{DD}$	-	-	10	μA
I_{PCC}	Operating V_{CC} Supply Current	$f_{IN} = 20\text{ kHz, rms, }V_{IN} = 15\text{ V}_{PP}$	-	430	-	μA
I_{PDD}	Operating V_{DD} Supply Current	$f_{IN} = 20\text{ kHz, rms, }V_{IN} = 15\text{ V}_{PP}$	-	300	-	μA
I_{SD}	Shutdown Supply Current	$S_D = V_{DD}$	-	120	-	μA
V_{CCUV+}	V_{CC} Supply Under-Voltage Positive-Going Threshold Voltage	$V_{IN} = 0\text{ V, }V_{CC} = \text{Sweep}$	7.7	8.8	9.9	V
V_{CCUV-}	V_{CC} Supply Under-Voltage Negative-Going Threshold Voltage	$V_{IN} = 0\text{ V, }V_{CC} = \text{Sweep}$	7.3	8.4	9.5	V
V_{CCUVH}	V_{CC} Supply Under-Voltage Lockout Hysteresis Voltage	$V_{IN} = 0\text{ V, }V_{CC} = \text{Sweep}$	-	0.4	-	V

BOOTSTRAPPED SUPPLY SECTION

I_{QBS}	Quiescent V_{BS} Supply Current	$V_{IN} = 0\text{ V or }V_{DD}$	-	60	130	μA
I_{PBS}	Operating V_{BS} Supply Current	$f_{IN} = 20\text{ kHz, rms value}$	-	500	-	μA
V_{BSUV+}	V_{BS} Supply Under-Voltage Positive-Going Threshold Voltage	$V_{IN} = 0\text{ V, }V_{BS} = \text{Sweep}$	7.7	8.8	9.9	V
V_{BSUV-}	V_{BS} Supply Under-Voltage Negative-Going Threshold Voltage	$V_{IN} = 0\text{ V, }V_{BS} = \text{Sweep}$	7.3	8.4	9.5	V
V_{BSUVH}	V_{BS} Supply Under-Voltage Lockout Hysteresis Voltage	$V_{IN} = 0\text{ V, }V_{BS} = \text{Sweep}$	-	0.4	-	V
I_{LK}	Offset Supply Leakage Current	$V_B = V_S = 600\text{ V}$	-	-	50	μA

INPUT LOGIC SECTION (HIN, LIN, AND SD)

V_{IH}	Logic "1" Input Threshold Voltage	$V_{DD} = 3\text{ V}$	2.4	-	-	V
		$V_{DD} = 15\text{ V}$	9.5	-	-	V
V_{IL}	Logic "0" Input Threshold Voltage	$V_{DD} = 3\text{ V}$	-	-	0.8	V
		$V_{DD} = 15\text{ V}$	-	-	4.5	V
I_{IN+}	Logic Input High Bias Current	$V_{IN} = V_{DD}$	-	20	40	μA
I_{IN-}	Logic Input Low Bias Current	$V_{IN} = 0\text{ V}$	-	-	3	μA
R_{IN}	Logic Input Pull-Down Resistance		375	750	-	$\text{k}\Omega$

GATE DRIVER OUTPUT SECTION

V_{OH}	High-Level Output Voltage ($V_{BIAS} - V_O$)	No Load ($I_O = 0\text{ A}$)	-	-	1.5	V
V_{OL}	Low-Level Output Voltage	No Load ($I_O = 0\text{ A}$)	-	-	200	mV
I_{O+}	Output High, Short-Circuit Pulsed Current (Note 4)	$V_O = 0\text{ V, }PW \leq [] 0\ \mu\text{s}$	2.5	3.0	-	A
I_{O-}	Output Low, Short-Circuit Pulsed Current (Note 4)	$V_O = 15\text{ V, }PW \leq [] 0\ \mu\text{s}$	2.5	3.0	-	A
V_{SS}/COM	V_{SS} -COM/COM- V_{SS} Voltage Endurability		-5.0	-	5.0	V
$-V_S$	Allowable Negative V_S Pin Voltage for HIN Signal Propagation to HO		-	-9.8	-7.0	V

Product parametric performance is indicated in the Electrical Characteristics for the listed test conditions, unless otherwise noted. Product performance may not be indicated by the Electrical Characteristics if operated under different conditions.

4. This parameter guaranteed by design.

FAN7392

DYNAMIC ELECTRICAL CHARACTERISTICS (V_{BIAS} (V_{CC} , V_{BS} , V_{DD}) = 15.0 V, V_{SS} = COM = 0V, C_{LOAD} = 1000 pF, T_A = 25°C, unless otherwise specified.)

Symbol	Characteristics	Test Condition	Min	Typ	Max	Unit
t_{on}	Turn-On Propagation Delay Time	$V_S = 0$ V	-	130	180	ns
t_{off}	Turn-Off Propagation Delay Time	$V_S = 0$ V	-	150	200	ns
t_{sd}	Shutdown Propagation Delay Time (Note 5)		-	130	180	
t_r	Turn-On Rise Time		-	25	50	
t_f	Turn-Off Fall Time		-	20	45	
MT	Delay Matching, HO & LO Turn-On/Off		-	-	35	

5. This parameter guaranteed by design.

DISCONTINUED
THIS DEVICE IS NOT RECOMMENDED FOR NEW DESIGN
PLEASE CONTACT YOUR onsemi
REPRESENTATIVE FOR INFORMATION

TYPICAL CHARACTERISTICS

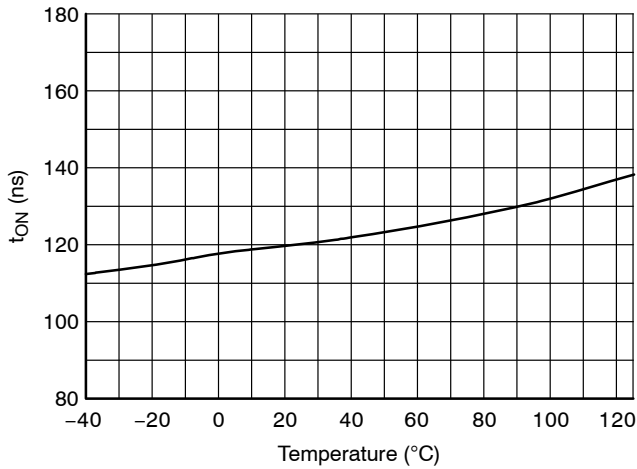

Figure 6. Turn-On Propagation Delay vs. Temperature

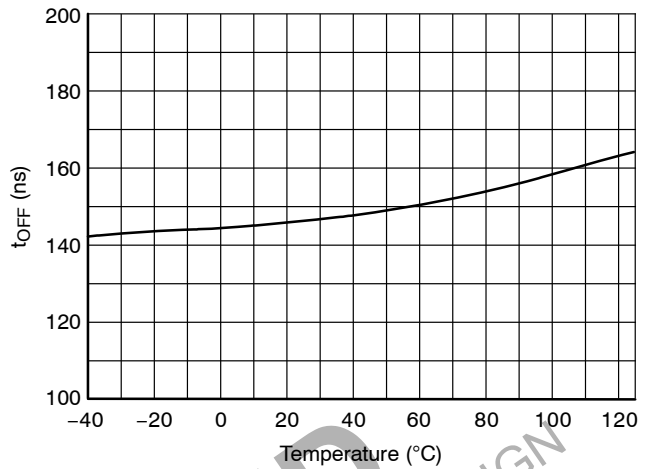

Figure 7. Turn-Off Propagation Delay vs. Temperature

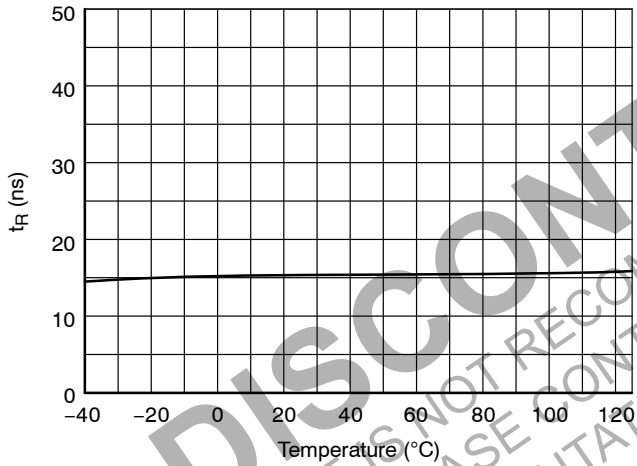

Figure 8. Turn-On Rise Time vs. Temperature

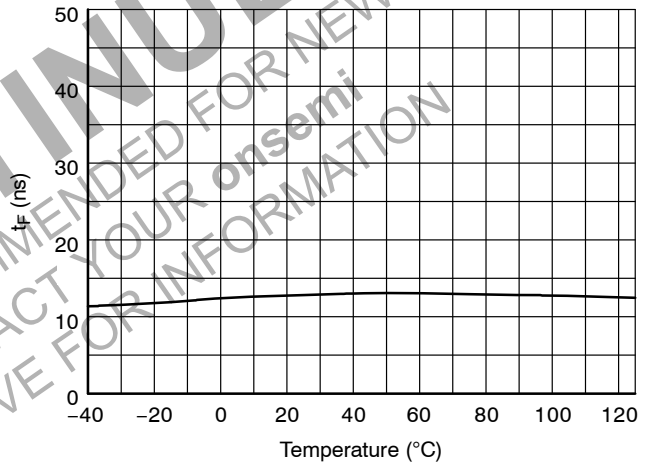

Figure 9. Turn-Off Fall Time vs. Temperature

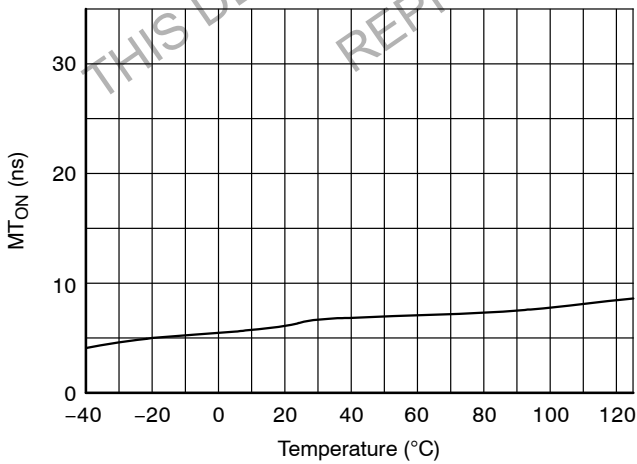

Figure 10. Turn-On Delay Matching vs. Temperature

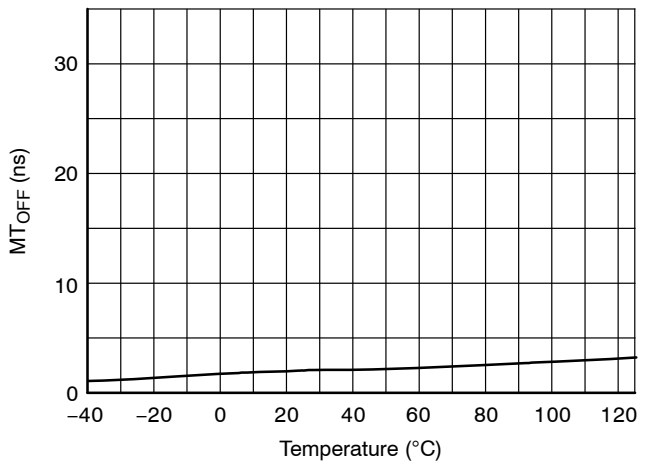

Figure 11. Turn-Off Delay Matching vs. Temperature

TYPICAL CHARACTERISTICS (continued)

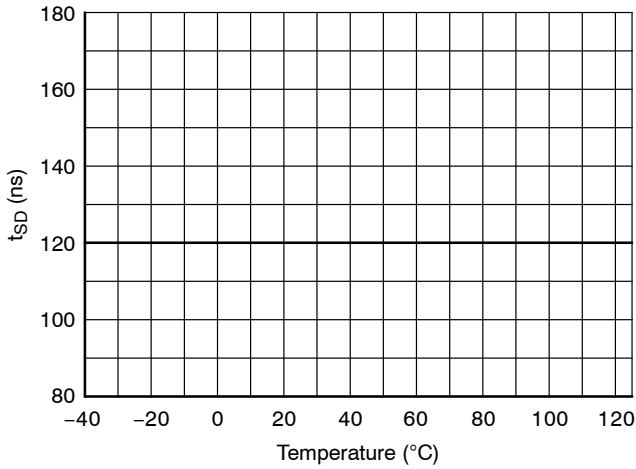

Figure 12. Shutdown Propagation Delay vs. Temperature

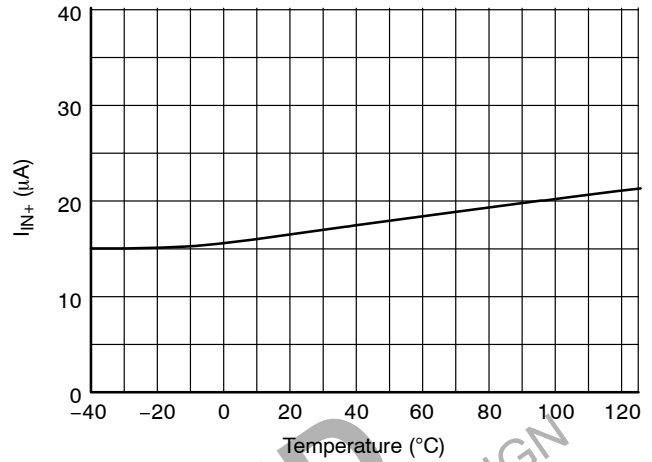

Figure 13. Logic Input High Bias Current vs. Temperature

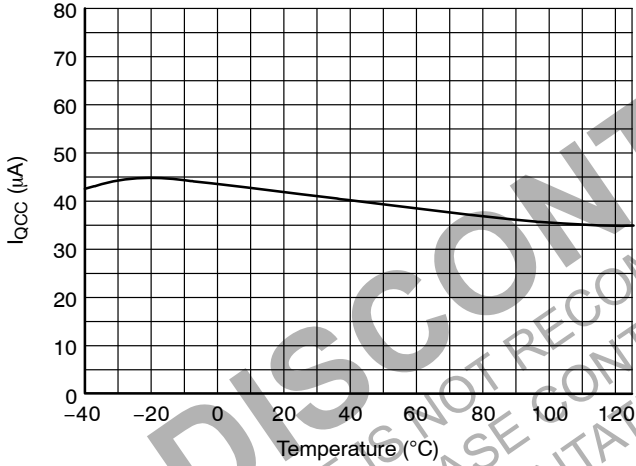

Figure 14. Quiescent V_{CC} Supply Current vs. Temperature

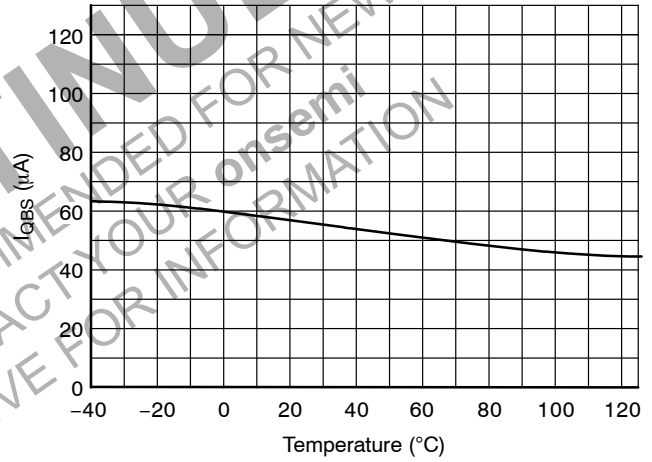

Figure 15. Quiescent V_{BS} Supply Current vs. Temperature

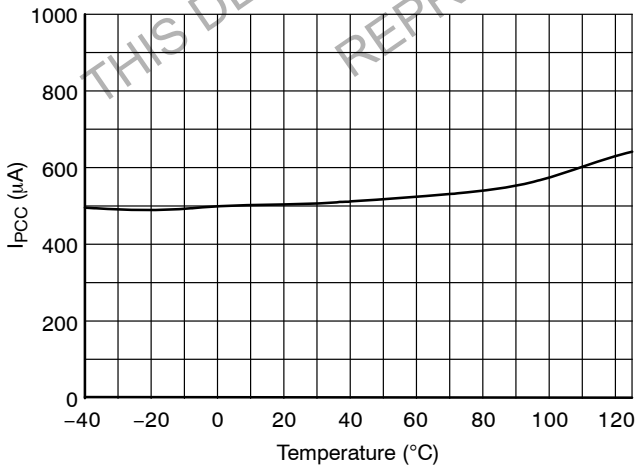

Figure 16. Operating V_{CC} Supply Current vs. Temperature

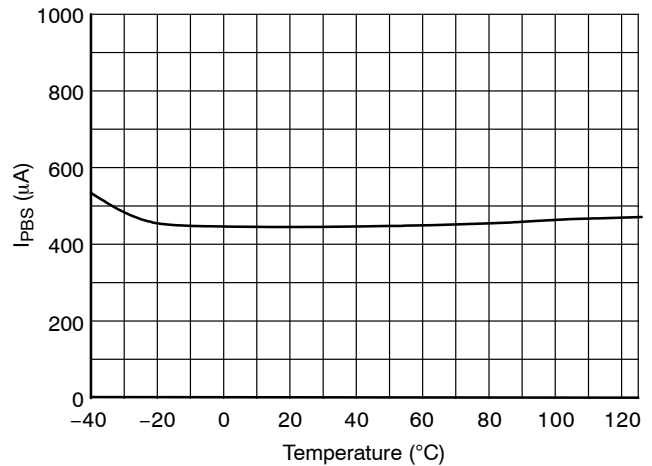

Figure 17. Operating V_{BS} Supply Current vs. Temperature

TYPICAL CHARACTERISTICS (continued)

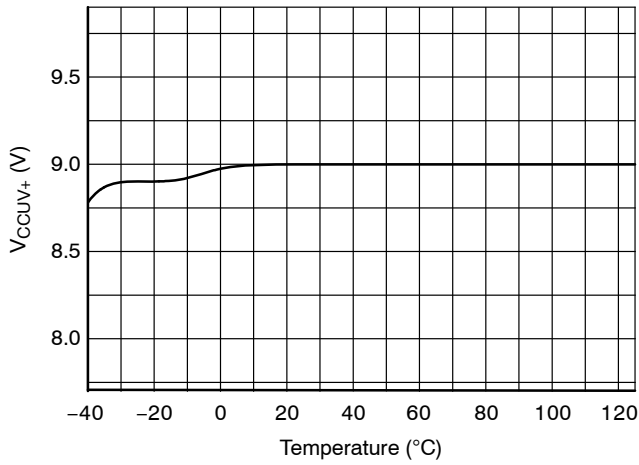

Figure 18. V_{CC} UVLO+ vs. Temperature

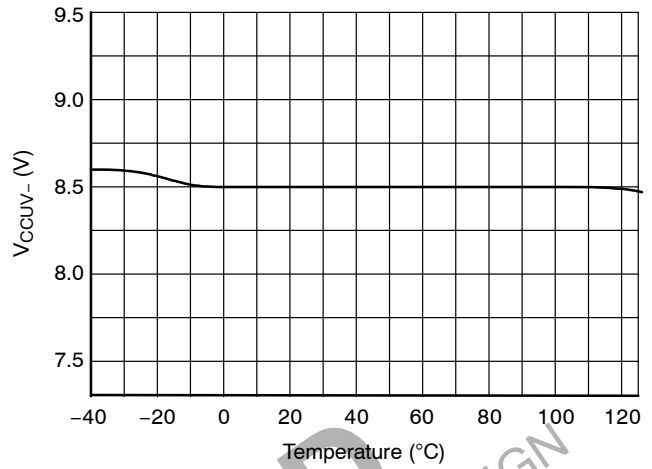

Figure 19. V_{CC} UVLO- vs. Temperature

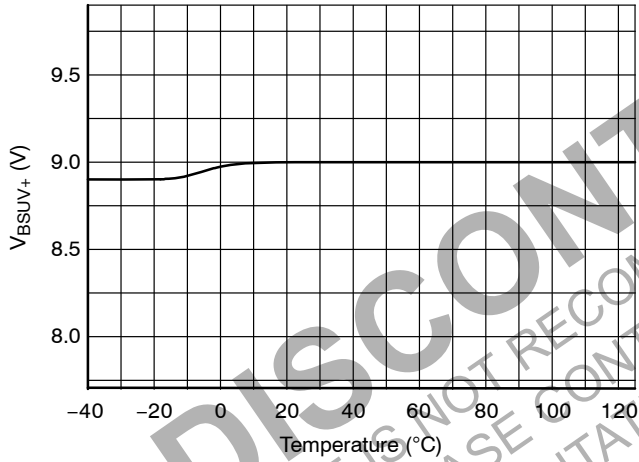

Figure 20. V_{BS} UVLO+ vs. Temperature

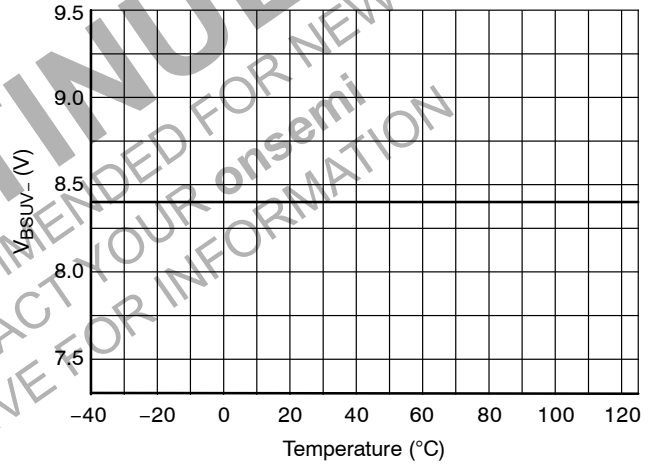

Figure 21. V_{BS} UVLO- vs. Temperature

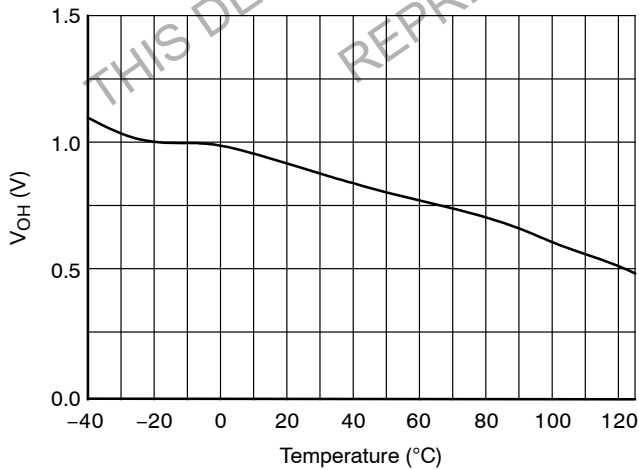

Figure 22. High-Level Output Voltage vs. Temperature

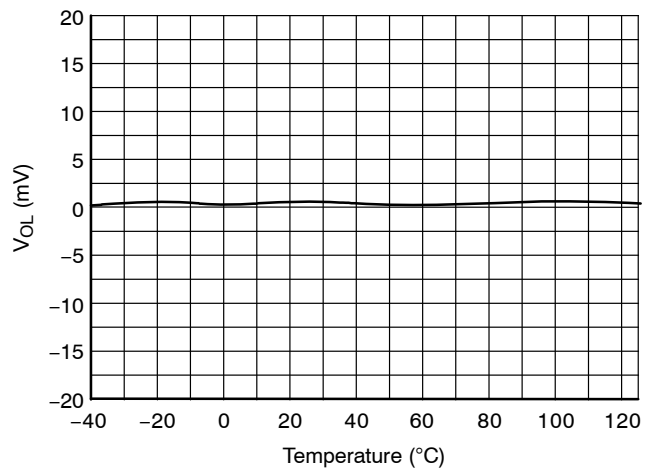

Figure 23. Low-Level Output Voltage vs. Temperature

TYPICAL CHARACTERISTICS (continued)

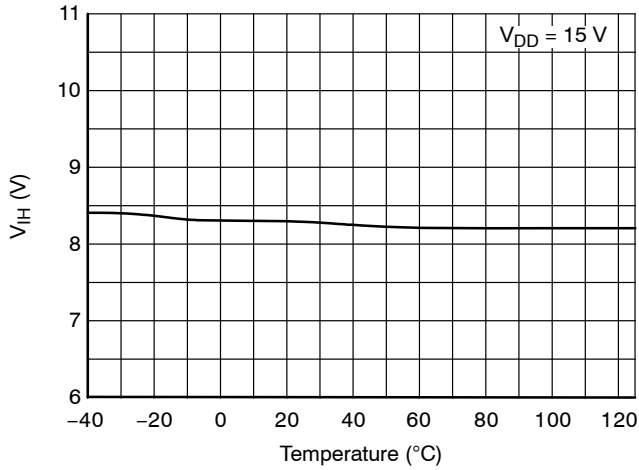

Figure 24. Logic High Input Voltage vs. Temperature

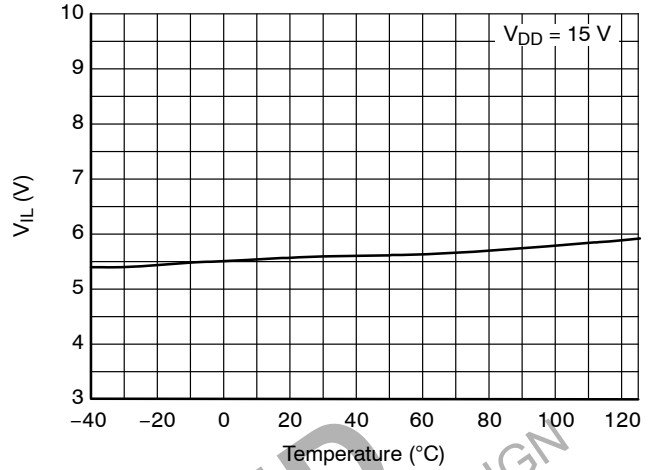

Figure 25. Logic Low Input Voltage vs. Temperature

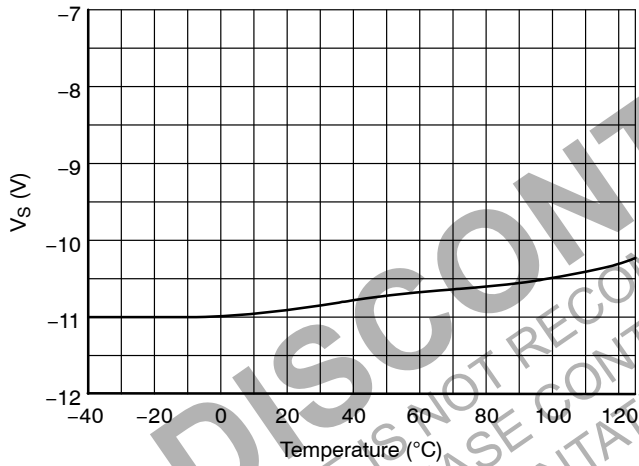

Figure 26. Allowable Negative V_S Voltage vs. Temperature

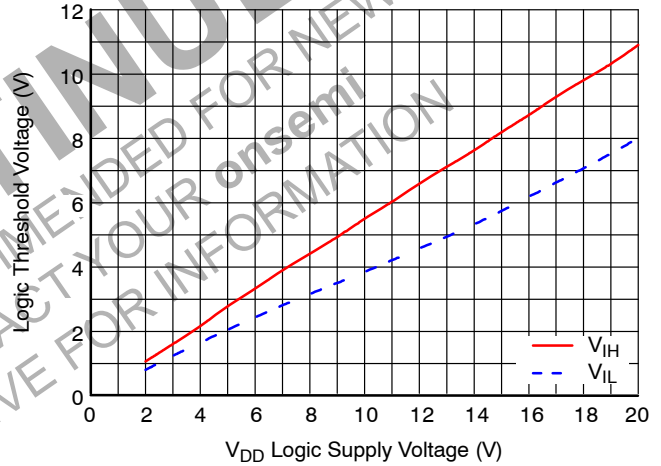

Figure 27. Input Logic (HIN & LIN) Threshold Voltage vs. V_{DD} Supply Voltage

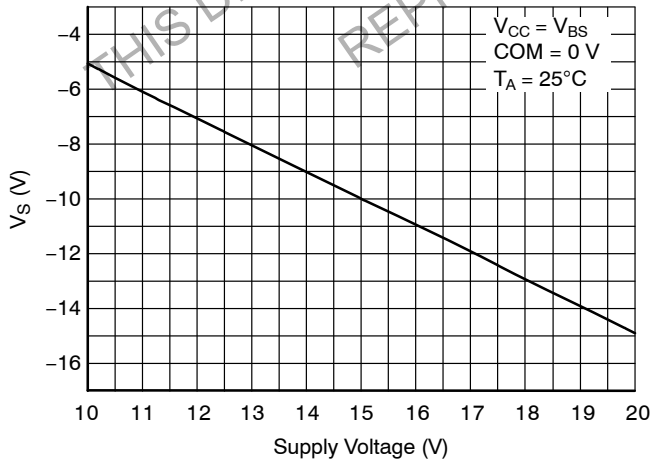

Figure 28. Allowable Negative V_S Voltage for HIN Signal Propagation to High Side vs. Supply Voltage

SWITCHING TIME DEFINITIONS

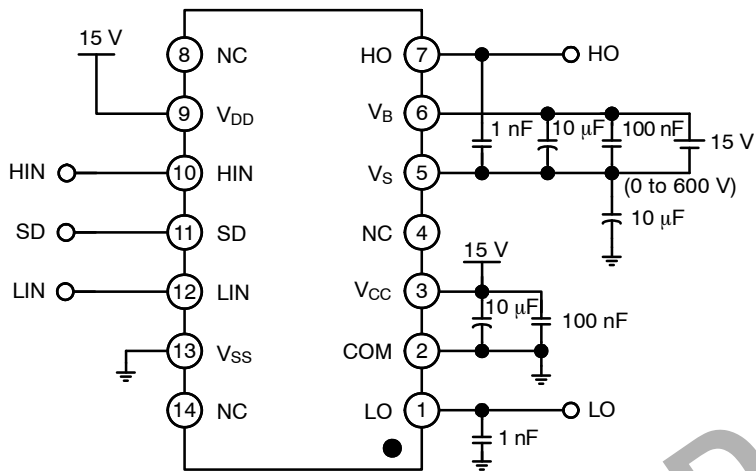

Figure 29. Switching Time Test Circuit (Referenced 14-DIP)

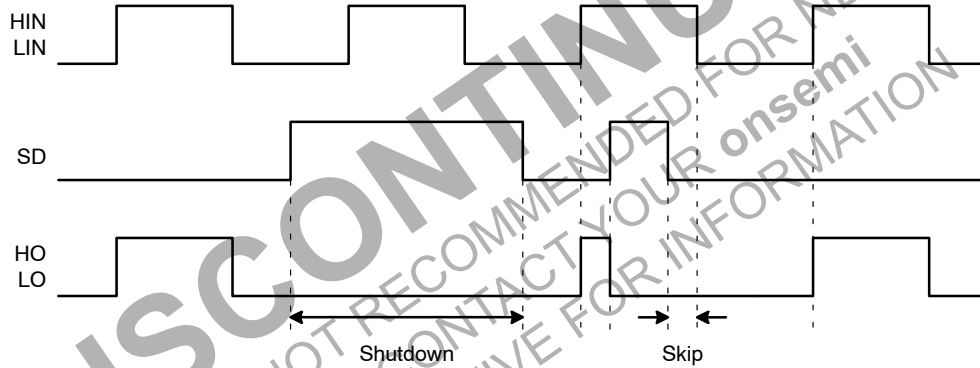

Figure 30. Input/Output Timing Diagram

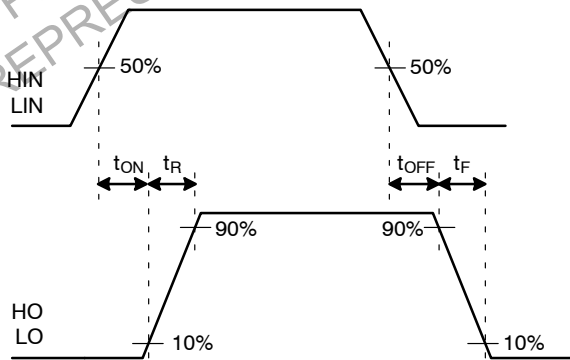

Figure 31. Switching Time Waveform Definitions

SWITCHING TIME DEFINITIONS (continued)

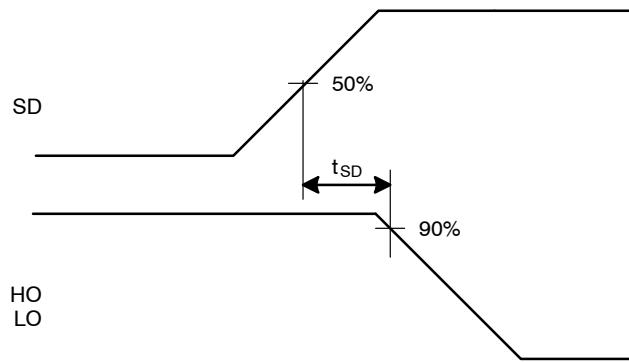

Figure 32. Shutdown Waveform Definition

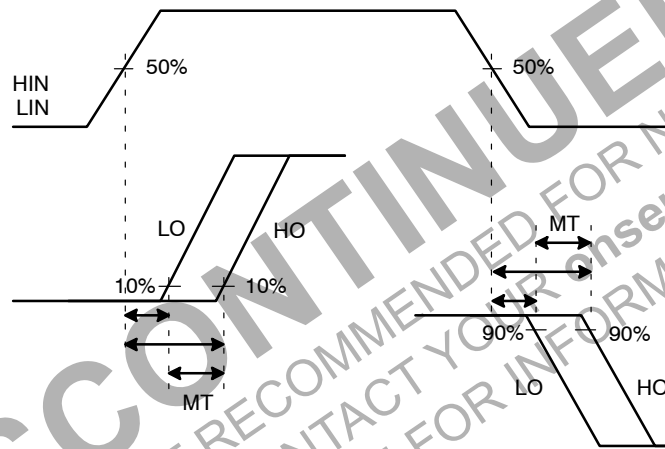

Figure 33. Delay Matching Waveform Definitions

DISCONTINUED

THIS DEVICE IS NOT RECOMMENDED FOR NEW DESIGN
PLEASE CONTACT YOUR onsemi REPRESENTATIVE FOR INFORMATION

APPLICATION INFORMATION

Negative V_S Transient

The bootstrap circuit has the advantage of being simple and low cost, but has some limitations. The biggest difficulty with this circuit is the negative voltage present at the emitter of the high-side switching device when high-side switch is turned-off in half-bridge application.

If the high-side switch, Q1, turns-off while the load current is flowing to an inductive load, a current commutation occurs from high-side switch, Q1, to the diode, D2, in parallel with the low-side switch of the same inverter leg. Then the negative voltage present at the emitter of the high-side switching device, just before the freewheeling diode, D2, starts clamping, causes load current to suddenly flow to the low-side freewheeling diode, D2, as shown in Figure 34.

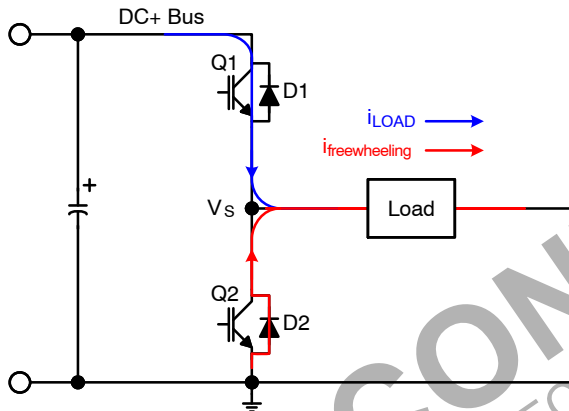

Figure 34. Half-Bridge Application Circuits

This negative voltage can be trouble for the gate driver's output stage, there is the possibility to develop an over-voltage condition of the bootstrap capacitor, input signal missing and latch-up problems because it directly affects the source V_S pin of the gate driver, as shown in Figure 35. This undershoot voltage is called "negative V_S transient".

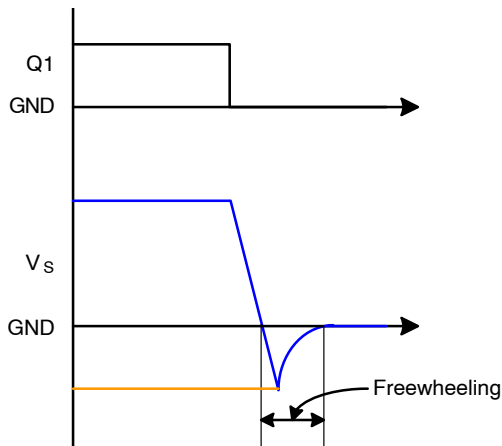

Figure 35. V_S Waveforms During Q1 Turn-Off

Figure 36 and Figure 37 show the commutation of the load current between high-side switch, Q1, and low-side freewheeling diode, D3, in same inverter leg. The parasitic inductances in the inverter circuit from the die wire bonding to the PCB tracks are jumped together in L_C and L_E for each IGBT. When the high-side switch, Q1, and low-side switch, Q4, are turned on, the V_{S1} node is below DC+ voltage by the voltage drops associated with the power switch and the parasitic inductances of the circuit due to load current is flows from Q1 and Q4, as shown in Figure 36. When the high-side switch, Q1, is turned off and Q4, remained turned on, the load current to flows the low-side freewheeling diode, D3, due to the inductive load connected to V_{S1} as shown in Figure 37. The current flows from ground (which is connected to the COM pin of the gate driver) to the load and the negative voltage present at the emitter of the high-side switching device.

In this case, the COM pin of the gate driver is at a higher potential than the V_S pin due to the voltage drops associated with freewheeling diode, D3, and parasitic elements, L_{C3} and L_{E3} .

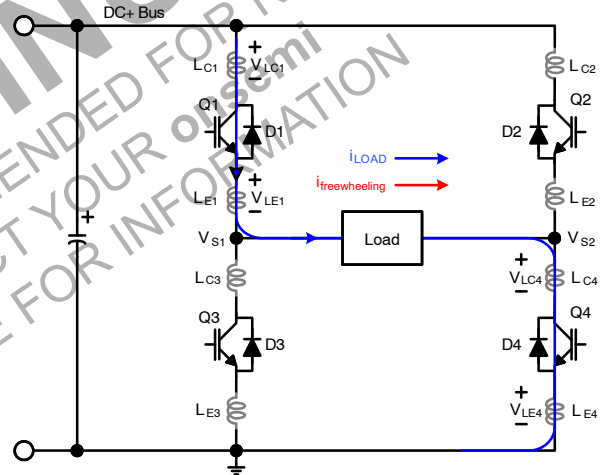

Figure 36. Q1 and Q4 Turn-On

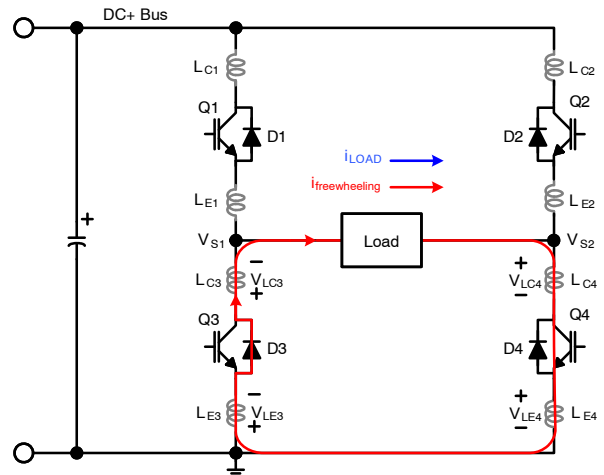

Figure 37. Q1 Turn-Off and D3 Conducting

The FAN7392 has a negative V_S transient performance curve, as shown in Figure 38.

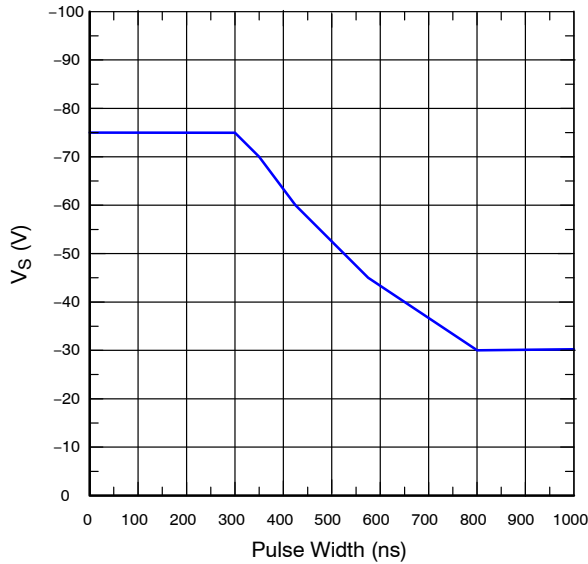

Figure 38. Negative V_S Transient Characteristic

Even though the FAN7392 has been shown able to handle these negative V_S transient conditions, it is strongly recommended that the circuit designer limit the negative V_S transient as much as possible by careful PCB layout to minimize the value of parasitic elements and component use. The amplitude of negative V_S voltage is proportional to the parasitic inductances and the turn-off speed, di/dt , of the switching device.

GENERAL GUIDELINES

Printed Circuit Board Layout

The relayout recommended for minimized parasitic elements is as follows:

- Direct tracks between switches with no loops or deviation.
- Avoid interconnect links. These can add significant inductance.
- Reduce the effect of lead-inductance by lowering package height above the PCB.
- Consider co-locating both power switches to reduce track length.

- To minimize noise coupling, the ground plane should not be placed under or near the high-voltage floating side.
- To reduce the EM coupling and improve the power switch turn-on/off performance, the gate drive loops must be reduced as much as possible.

Placement of Components

The recommended placement and selection of component as follows:

- Place a bypass capacitor between the V_{DD} and V_{SS} pins. A ceramic 1 μ F capacitor is suitable for most applications. This component should be placed as close as possible to the pins to reduce parasitic elements.
- The bypass capacitor from V_{CC} to COM supports both the low-side driver and bootstrap capacitor recharge. A value at least ten times higher than the bootstrap capacitor is recommended.
- The bootstrap resistor, R_{BOOT} , must be considered in sizing the bootstrap resistance and the current developed during initial bootstrap charge. If the resistor is needed in series with the bootstrap diode, verify that V_B does not fall below COM (ground). Recommended use is typically 5-10 Ω that increase the V_{BS} time constant. If the voltage drop of bootstrap resistor and diode is too high or the circuit topology does not allow a sufficient charging time, a fast recovery or ultra-fast recovery diode can be used.
- The bootstrap capacitor, C_{BOOT} , uses a low-ESR capacitor, such as ceramic capacitor.

It is strongly recommended that the placement of components is as follows:

- Place components tied to the floating voltage pins (V_B and V_S) near the respective high-voltage portions of the device and the FAN7392. NC (not connected) pins in this package maximize the distance between the high-voltage and low-voltage pins (see Figure 5).
- Place and route for bypass capacitors and gate resistors as close as possible to gate drive IC.
- Locate the bootstrap diode, D_{BOOT} , as close as possible to bootstrap capacitor, C_{BOOT} .
- The bootstrap diode must use a lower forward voltage drop and minimal switching time as soon as possible for fast recovery or ultra-fast diode.

ORDERING INFORMATION

Device	Operating Temperature Range	Package	Shipping†
FAN7392N	-40°C~125°C	PDIP-14 14-PDIP (Pb-Free)	1500 Units / Tube
FAN7392MX		SOIC-16 16-SOP (Pb-Free)	1000 / Tape & Reel

†For information on tape and reel specifications, including part orientation and tape sizes, please refer to our Tape and Reel Packaging Specifications Brochure, BRD8011/D.

MECHANICAL CASE OUTLINE PACKAGE DIMENSIONS

ON Semiconductor®

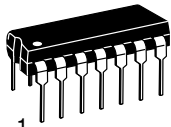

SCALE 1:1

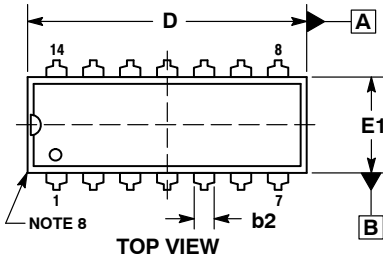

PDIP-14
CASE 646-06
ISSUE S

DATE 22 APR 2015

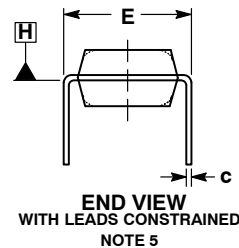

NOTES:

1. DIMENSIONING AND TOLERANCING PER ASME Y14.5M, 1994.
2. CONTROLLING DIMENSION: INCHES.
3. DIMENSIONS A, A1 AND L ARE MEASURED WITH THE PACKAGE SEATED IN JEDEC SEATING PLANE GAUGE GS-3.
4. DIMENSIONS D, D1 AND E1 DO NOT INCLUDE MOLD FLASH OR PROTRUSIONS. MOLD FLASH OR PROTRUSIONS ARE NOT TO EXCEED 0.10 INCH.
5. DIMENSION E IS MEASURED AT A POINT 0.015 BELOW DATUM PLANE H WITH THE LEADS CONSTRAINED PERPENDICULAR TO DATUM C.
6. DIMENSION eB IS MEASURED AT THE LEAD TIPS WITH THE LEADS UNCONSTRAINED.
7. DATUM PLANE H IS COINCIDENT WITH THE BOTTOM OF THE LEADS, WHERE THE LEADS EXIT THE BODY.
8. PACKAGE CONTOUR IS OPTIONAL (ROUNDED OR SQUARE CORNERS).

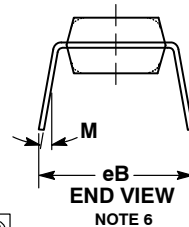
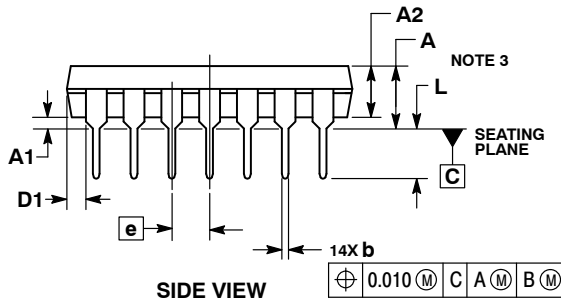

DIM	INCHES		MILLIMETERS	
	MIN	MAX	MIN	MAX
A	----	0.210	----	5.33
A1	0.015	----	0.38	----
A2	0.115	0.195	2.92	4.95
b	0.014	0.022	0.35	0.56
b2	0.060 TYP		1.52 TYP	
C	0.008	0.014	0.20	0.36
D	0.735	0.775	18.67	19.69
D1	0.005	----	0.13	----
E	0.300	0.325	7.62	8.26
E1	0.240	0.280	6.10	7.11
e	0.100 BSC		2.54 BSC	
eB	----	0.430	----	10.92
L	0.115	0.150	2.92	3.81
M	----	10°	----	10°

GENERIC MARKING DIAGRAM*

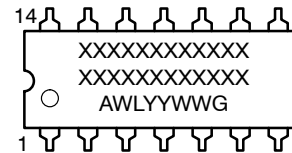

- XXXXX = Specific Device Code
- A = Assembly Location
- WL = Wafer Lot
- YY = Year
- WW = Work Week
- G = Pb-Free Package

*This information is generic. Please refer to device data sheet for actual part marking. Pb-Free indicator, "G" or microdot "▪", may or may not be present.

STYLES ON PAGE 2

DOCUMENT NUMBER:	98ASB42428B	Electronic versions are uncontrolled except when accessed directly from the Document Repository. Printed versions are uncontrolled except when stamped "CONTROLLED COPY" in red.
DESCRIPTION:	PDIP-14	PAGE 1 OF 2

ON Semiconductor and ON are trademarks of Semiconductor Components Industries, LLC dba ON Semiconductor or its subsidiaries in the United States and/or other countries. ON Semiconductor reserves the right to make changes without further notice to any products herein. ON Semiconductor makes no warranty, representation or guarantee regarding the suitability of its products for any particular purpose, nor does ON Semiconductor assume any liability arising out of the application or use of any product or circuit, and specifically disclaims any and all liability, including without limitation special, consequential or incidental damages. ON Semiconductor does not convey any license under its patent rights nor the rights of others.

PDIP-14
CASE 646-06
ISSUE S

DATE 22 APR 2015

STYLE 1:
 PIN 1. COLLECTOR
 2. BASE
 3. EMITTER
 4. NO
 CONNECTION
 5. EMITTER
 6. BASE
 7. COLLECTOR
 8. COLLECTOR
 9. BASE
 10. EMITTER
 11. NO
 CONNECTION
 12. EMITTER
 13. BASE
 14. COLLECTOR

STYLE 2:
 CANCELLED

STYLE 3:
 CANCELLED

STYLE 4:
 PIN 1. DRAIN
 2. SOURCE
 3. GATE
 4. NO
 CONNECTION
 5. GATE
 6. SOURCE
 7. DRAIN
 8. DRAIN
 9. SOURCE
 10. GATE
 11. NO
 CONNECTION
 12. GATE
 13. SOURCE
 14. DRAIN

STYLE 5:
 PIN 1. GATE
 2. DRAIN
 3. SOURCE
 4. NO CONNECTION
 5. SOURCE
 6. DRAIN
 7. GATE
 8. GATE
 9. DRAIN
 10. SOURCE
 11. NO CONNECTION
 12. SOURCE
 13. DRAIN
 14. GATE

STYLE 6:
 PIN 1. COMMON CATHODE
 2. ANODE/CATHODE
 3. ANODE/CATHODE
 4. NO CONNECTION
 5. ANODE/CATHODE
 6. NO CONNECTION
 7. ANODE/CATHODE
 8. ANODE/CATHODE
 9. ANODE/CATHODE
 10. NO CONNECTION
 11. ANODE/CATHODE
 12. ANODE/CATHODE
 13. NO CONNECTION
 14. COMMON ANODE

STYLE 7:
 PIN 1. NO CONNECTION
 2. ANODE
 3. ANODE
 4. NO CONNECTION
 5. ANODE
 6. NO CONNECTION
 7. ANODE
 8. ANODE
 9. ANODE
 10. NO CONNECTION
 11. ANODE
 12. ANODE
 13. NO CONNECTION
 14. COMMON
 CATHODE

STYLE 8:
 PIN 1. NO CONNECTION
 2. CATHODE
 3. CATHODE
 4. NO CONNECTION
 5. CATHODE
 6. NO CONNECTION
 7. CATHODE
 8. CATHODE
 9. CATHODE
 10. NO CONNECTION
 11. CATHODE
 12. CATHODE
 13. NO CONNECTION
 14. COMMON ANODE

STYLE 9:
 PIN 1. COMMON CATHODE
 2. ANODE/CATHODE
 3. ANODE/CATHODE
 4. NO CONNECTION
 5. ANODE/CATHODE
 6. ANODE/CATHODE
 7. COMMON ANODE
 8. COMMON ANODE
 9. ANODE/CATHODE
 10. ANODE/CATHODE
 11. NO CONNECTION
 12. ANODE/CATHODE
 13. ANODE/CATHODE
 14. COMMON CATHODE

STYLE 10:
 PIN 1. COMMON
 CATHODE
 2. ANODE/CATHODE
 3. ANODE/CATHODE
 4. ANODE/CATHODE
 5. ANODE/CATHODE
 6. NO CONNECTION
 7. COMMON ANODE
 8. COMMON
 CATHODE
 9. ANODE/CATHODE
 10. ANODE/CATHODE
 11. ANODE/CATHODE
 12. ANODE/CATHODE
 13. NO CONNECTION
 14. COMMON ANODE

STYLE 11:
 PIN 1. CATHODE
 2. CATHODE
 3. CATHODE
 4. CATHODE
 5. CATHODE
 6. CATHODE
 7. CATHODE
 8. ANODE
 9. ANODE
 10. ANODE
 11. ANODE
 12. ANODE
 13. ANODE
 14. ANODE

STYLE 12:
 PIN 1. COMMON CATHODE
 2. COMMON ANODE
 3. ANODE/CATHODE
 4. ANODE/CATHODE
 5. ANODE/CATHODE
 6. COMMON ANODE
 7. COMMON CATHODE
 8. ANODE/CATHODE
 9. ANODE/CATHODE
 10. ANODE/CATHODE
 11. ANODE/CATHODE
 12. ANODE/CATHODE
 13. ANODE/CATHODE
 14. ANODE/CATHODE

DOCUMENT NUMBER:	98ASB42428B	Electronic versions are uncontrolled except when accessed directly from the Document Repository. Printed versions are uncontrolled except when stamped "CONTROLLED COPY" in red.
DESCRIPTION:	PDIP-14	PAGE 2 OF 2

ON Semiconductor and  are trademarks of Semiconductor Components Industries, LLC dba ON Semiconductor or its subsidiaries in the United States and/or other countries. ON Semiconductor reserves the right to make changes without further notice to any products herein. ON Semiconductor makes no warranty, representation or guarantee regarding the suitability of its products for any particular purpose, nor does ON Semiconductor assume any liability arising out of the application or use of any product or circuit, and specifically disclaims any and all liability, including without limitation special, consequential or incidental damages. ON Semiconductor does not convey any license under its patent rights nor the rights of others.



SOIC-16, 300 mils
CASE 751BH-01
ISSUE A

DATE 18 MAR 2009

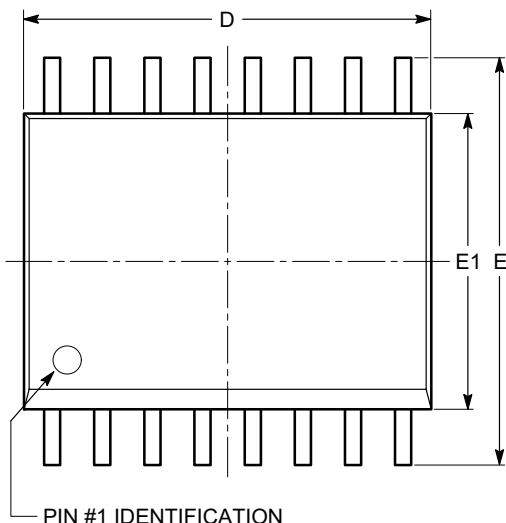

TOP VIEW

SYMBOL	MIN	NOM	MAX
A	2.36	2.49	2.64
A1	0.10		0.30
b	0.33	0.41	0.51
c	0.18	0.23	0.28
D	10.08	10.31	10.49
E	10.01	10.31	10.64
E1	7.39	7.49	7.59
e	1.27 BSC		
h	0.25		0.75
L	0.38	0.81	1.27
θ	0°		8°

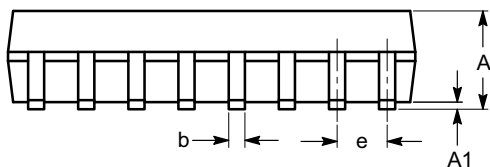

SIDE VIEW

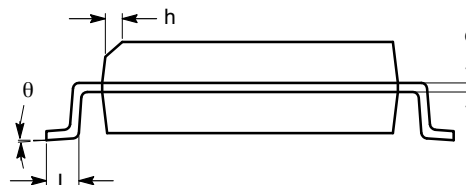

END VIEW

Notes:

- (1) All dimensions are in millimeters. Angles in degrees.
- (2) Complies with JEDEC MS-013.

DOCUMENT NUMBER:	98AON34279E	Electronic versions are uncontrolled except when accessed directly from the Document Repository. Printed versions are uncontrolled except when stamped "CONTROLLED COPY" in red.
DESCRIPTION:	SOIC-16, 300 MILS	PAGE 1 OF 1

ON Semiconductor and are trademarks of Semiconductor Components Industries, LLC dba ON Semiconductor or its subsidiaries in the United States and/or other countries. ON Semiconductor reserves the right to make changes without further notice to any products herein. ON Semiconductor makes no warranty, representation or guarantee regarding the suitability of its products for any particular purpose, nor does ON Semiconductor assume any liability arising out of the application or use of any product or circuit, and specifically disclaims any and all liability, including without limitation special, consequential or incidental damages. ON Semiconductor does not convey any license under its patent rights nor the rights of others.

onsemi, **Onsemi**, and other names, marks, and brands are registered and/or common law trademarks of Semiconductor Components Industries, LLC dba "**onsemi**" or its affiliates and/or subsidiaries in the United States and/or other countries. **onsemi** owns the rights to a number of patents, trademarks, copyrights, trade secrets, and other intellectual property. A listing of **onsemi**'s product/patent coverage may be accessed at www.onsemi.com/site/pdf/Patent-Marking.pdf. **onsemi** reserves the right to make changes at any time to any products or information herein, without notice. The information herein is provided "as-is" and **onsemi** makes no warranty, representation or guarantee regarding the accuracy of the information, product features, availability, functionality, or suitability of its products for any particular purpose, nor does **onsemi** assume any liability arising out of the application or use of any product or circuit, and specifically disclaims any and all liability, including without limitation special, consequential or incidental damages. Buyer is responsible for its products and applications using **onsemi** products, including compliance with all laws, regulations and safety requirements or standards, regardless of any support or applications information provided by **onsemi**. "Typical" parameters which may be provided in **onsemi** data sheets and/or specifications can and do vary in different applications and actual performance may vary over time. All operating parameters, including "Typicals" must be validated for each customer application by customer's technical experts. **onsemi** does not convey any license under any of its intellectual property rights nor the rights of others. **onsemi** products are not designed, intended, or authorized for use as a critical component in life support systems or any FDA Class 3 medical devices or medical devices with a same or similar classification in a foreign jurisdiction or any devices intended for implantation in the human body. Should Buyer purchase or use **onsemi** products for any such unintended or unauthorized application, Buyer shall indemnify and hold **onsemi** and its officers, employees, subsidiaries, affiliates, and distributors harmless against all claims, costs, damages, and expenses, and reasonable attorney fees arising out of, directly or indirectly, any claim of personal injury or death associated with such unintended or unauthorized use, even if such claim alleges that **onsemi** was negligent regarding the design or manufacture of the part. **onsemi** is an Equal Opportunity/Affirmative Action Employer. This literature is subject to all applicable copyright laws and is not for resale in any manner.

ADDITIONAL INFORMATION

TECHNICAL PUBLICATIONS:



Technical Library: www.onsemi.com/design/resources/technical-documentation
onsemi Website: www.onsemi.com

ONLINE SUPPORT: www.onsemi.com/support

For additional information, please contact your local Sales Representative at www.onsemi.com/support/sales

Looking for pricing, stock, or lifecycle information?

Click below to explore more details on WIN SOURCE:

-  [View FAN7392M on WIN SOURCE](#)
-  [ON Semiconductor](#) Information

Optimize Your Supply Chain with WIN SOURCE Solutions

-  Global Sourcing Solution
-  Obsolete Management
-  Cost Control Management
-  Shortage Management
-  Alternative Solution
-  Excess Inventory Management