



**THE DATASHEET OF
CL8800K63-G**



Sequential Linear LED Driver

Features

- Minimal component count (base config: CL8800 + 6 resistors + diode bridge)
- No magnetics, no capacitors
- Up to 7.5W output (13W w/ heat sink)
- >110lm/W using efficient LEDs
- 85% typical electrical efficiency
- >0.95 power factor
- <20% THD line current
- Low conducted EMI w/o filters
- 85% LED luminous utilization
- Phase dimmer compatible with an RC network

Applications

- Fluorescent tube retrofit
- Incandescent & CFL bulb replacement
- General LED lighting

Description

CL8800 is designed to drive a long string of inexpensive, low-current LEDs directly from the AC mains. A basic driver circuit consists of CL8800, six resistors, and a bridge rectifier. Two to four additional components are optional for various levels of transient protection. No capacitors, EMI filters, or power factor correction circuits are needed.

A string of series/parallel LEDs is tapped at six locations. Six linear current regulators sink current at each tap and are sequentially turned on and off. Thereby tracking the input sine wave voltage. Voltage across each regulator is minimized when conducting, providing high efficiency. Output current at each tap is individually resistor-adjustable. Cross-regulation, as the CL8800 switches from one regulator to another, provides smooth transitions. The current waveform can be tailored to optimize for input voltage range, line/load regulation, output power/current, efficiency, power factor, THD, dimmer compatibility, and LED utilization.

With the addition of an RC network, the driver is compatible with phase dimming.

CL8800

Package Type

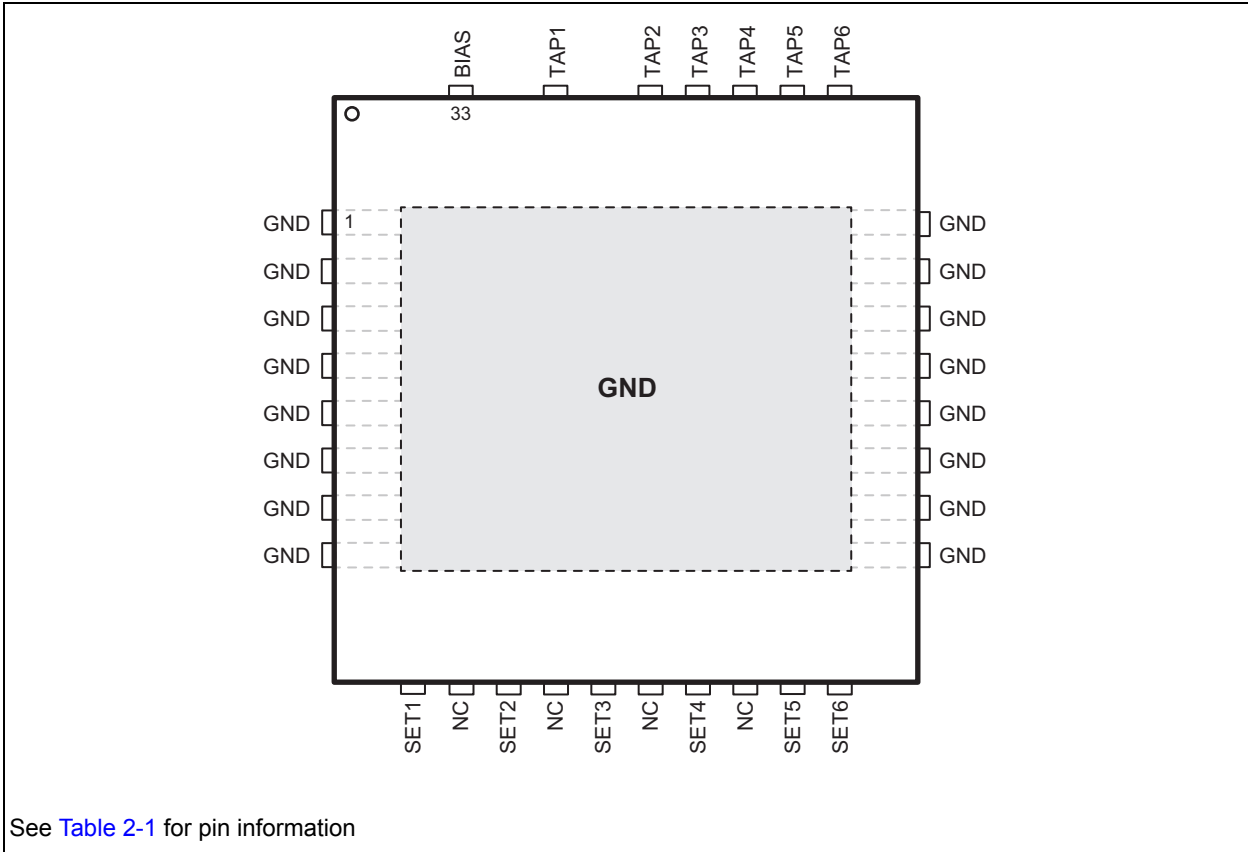

Typical Application Circuit

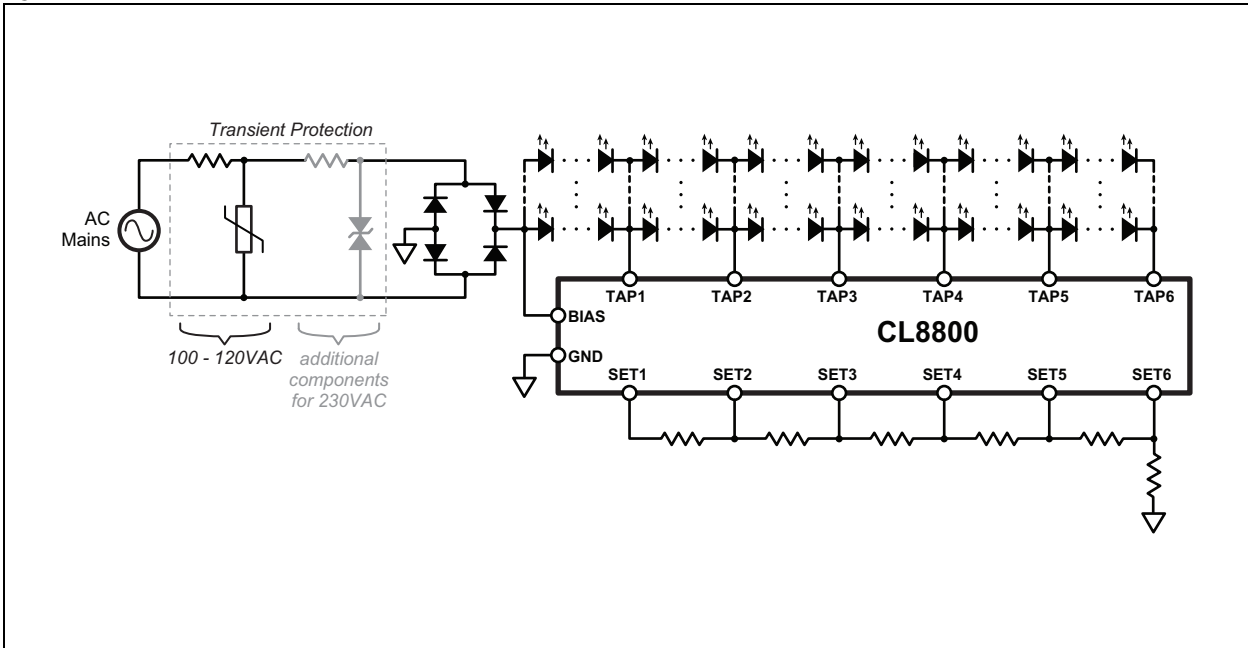

1.0 ELECTRICAL CHARACTERISTICS

ABSOLUTE MAXIMUM RATINGS

V_{BIAS}, V_{TAP1}	-0.5V to +550V
V_{TAP2-6}	-50V to +320V
V_{SET1-6}	4.0V
Operating temperature.....	-55°C to +125°C
Storage temperature, T_S	-65°C to +150°C

Note: Absolute Maximum Ratings are those values beyond which damage to the device may occur. Functional operation under these conditions is not implied. Continuous operation of the device at the absolute rating level may affect device reliability. All voltages are referenced to device ground.

1.1 ELECTRICAL SPECIFICATIONS

TABLE 1-1: RECOMMENDED OPERATING CONDITIONS

Symbol	Parameter	Min	Typ	Max	Units	Conditions
I_{OUT}	Output Current	TAP1		60	mA	
		TAP2		90	mA	
		TAP3		115	mA	
		TAP4		115	mA	
		TAP5		115	mA	
		TAP6		115	mA	
V_{OUT}	Output Voltage	TAP1		400	V	Non-conducting
		TAP2-6		300	V	Non-conducting
		TAP1-6		varies ¹	V	Conducting
V_{BIAS}	Applied BIAS voltage			440	V	

1 Voltage capability is determined by power dissipation ($V * I$).

TABLE 1-2: ELECTRICAL CHARACTERISTICS¹

Symbol	Parameter	Min	Typ	Max	Units	Conditions	
I_{BIAS}	BIAS pin input current		250	410	μ A	$V_{BIAS} = 340V$	
$I_{TAP(ON)}$	Output current, on	TAP1	60			mA	$V_{TAP1} = 30V, V_{SET1-6} = GND$
		TAP2	90			mA	$V_{TAP2} = 17V, V_{SET1-6} = GND$
		TAP3	115			mA	$V_{TAP3} = 17V, V_{SET1-6} = GND$
		TAP4	115			mA	$V_{TAP4} = 17V, V_{SET1-6} = GND$
		TAP5	115			mA	$V_{TAP5} = 17V, V_{SET1-6} = GND$
		TAP6	115			mA	$V_{TAP6} = 17V, V_{SET1-6} = GND$
$I_{TAP(OFF)}$	Output current, off		0	10	μ A	Tap 1-5, $V_{BIAS} = 312V$	
V_{REG}	Regulation voltage at SET pins	SET1-5	1.80	2.00	2.20	V	
		SET6	1.89	2.10	2.31	V	

1 Over recommended operating conditions at 25°C, unless specified otherwise.

CL8800

TABLE 1-3: THERMAL RESISTANCE

Package	θ_{ja}^1	θ_{jc}^2
33-Lead QFN	24°C/W	2.5°C/W

- 1.0 oz Cu 4-layer board, 3x4" PCB with thermal pad and thermal via array.
- Junction to exposed heat slug.

FIGURE 1-1: OUTPUT CURRENT THERMAL CHARACTERISTICS

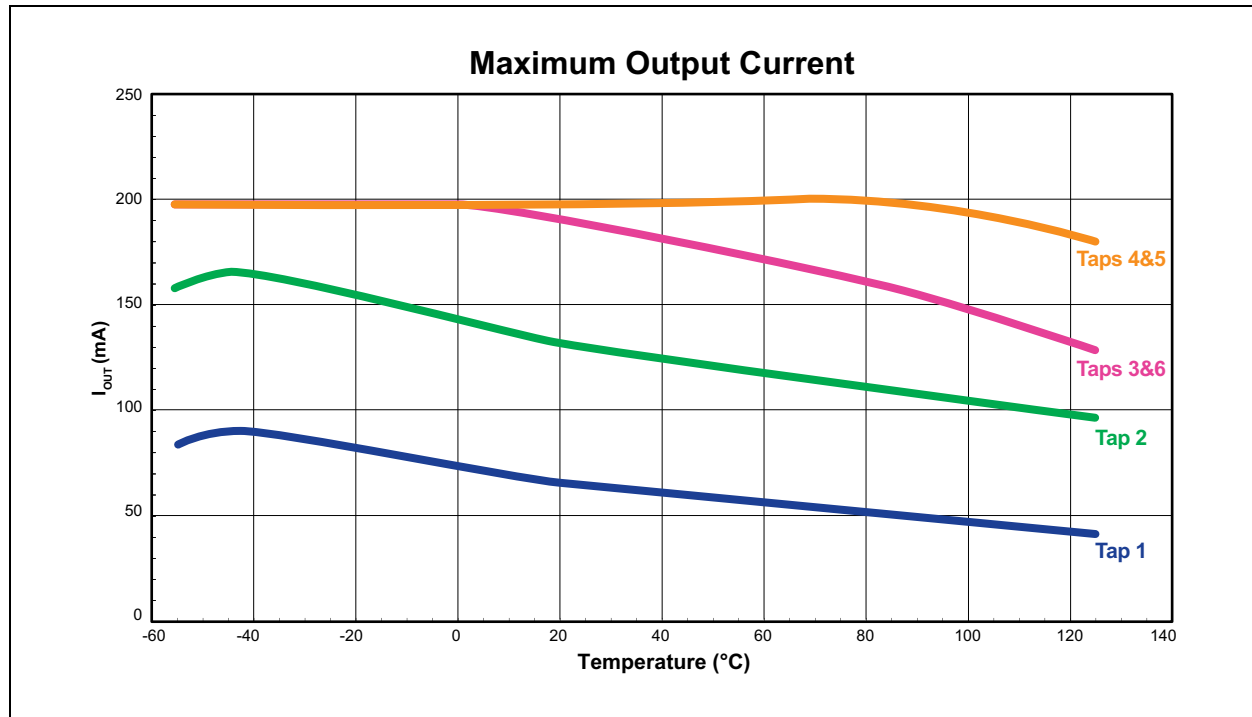

2.0 PIN DESCRIPTION

The locations of the pins are listed in [Package Type](#).

TABLE 2-1: PIN DESCRIPTION

Pin #	Function	Description
1 - 8	GND	Circuit common (use for heat sink ground plane pass through).
9	SET1	Current sense for linear current regulators for each tap. Resistors on these pins sets the tap currents.
10	NC	No internal connection.
11	SET2	Current sense for linear current regulators for each tap. Resistors on these pins sets the tap currents.
12	NC	No internal connection.
13	SET3	Current sense for linear current regulators for each tap. Resistors on these pins sets the tap currents.
14	NC	No internal connection.
15	SET4	Current sense for linear current regulators for each tap. Resistors on these pins sets the tap currents.
16	NC	No internal connection.
17	SET5	Current sense for linear current regulators for each tap. Resistors on these pins sets the tap currents.
18	SET6	Current sense for linear current regulators for each tap. Resistors on these pins sets the tap currents.
19 - 20	GND	Circuit common (use for heat sink ground plane pass through).
21	GND	Circuit common. Connect to bridge rectifier return (use for heat sink ground plane pass through).
22 - 26	GND	Circuit common (use for heat sink ground plane pass through).
27	TAP6	Current regulator outputs. Connect to taps along the LED string.
28	TAP5	
29	TAP4	
30	TAP3	
31	TAP2	
32	TAP1	
33	BIAS	Provides bias for driver. Connect to rectified AC.
Underside plate (GND)		For heat sinking purposes, it should be soldered to a 4.0cm ² exposed copper area. It should also be electrically connected to circuit common (GND).

3.0 APPLICATION INFORMATION

3.1 Overview

Designing a driver to meet particular requirements may be a difficult task considering the 18 design variables: tap current (6), number of series-connected LEDs per segment (6), and the number of parallel-connected LEDs per segment (6). Manually selecting values will provide light, but the chosen values may be far from optimal in regards to efficiency, LED utilization, and line regulation.

Contact your nearest Microchip Field Applications Engineer for design assistance.

In addition to configuring the driver, several circuits may be employed to increase reliability, performance, and cost. The following sections briefly describe these circuits.

3.2 Transient Protection

The driver circuits have no need for capacitors that could otherwise absorb transient energy, nor is there a need for EMI filters that would block transients. Therefore, the full burden of transient protection is borne by the protection circuit. The two-stage approach in the following schematics provide 2.5kV protection, both pulse and ring per EN 61000-4-5 and EN 61000-4-12, six hits each.

FIGURE 3-1: 100 TO 120 VAC TRANSIENT PROTECTION

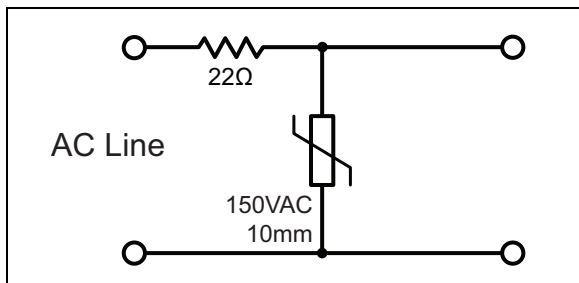
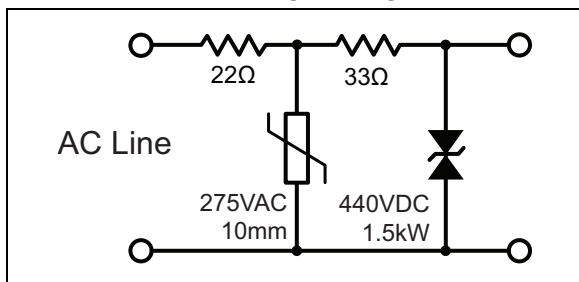

FIGURE 3-2: 230VAC TRANSIENT PROTECTION



3.3 Zener Diode Substitution

Zener diodes may be substituted for LEDs in the bottom stages of the design. The last 1 or 2 stages of LEDs contribute little to the light output - they are mainly present to off-load the adjacent upstream regulator at high line voltages to minimize losses. The advantages of Zener substitution includes minimizing unlit LEDs at low line for better light uniformity, better line regulation at high line, fewer LEDs for lower cost and less PCB area, and fewer board-to-board connections. Disadvantages include slightly-reduced efficiency at high line, and additional heat load on the driver board.

3.4 Phase Dimming

As with any light load, the LED lamp might not draw enough current to ensure proper dimmer operation. This is especially true for 230VAC dimmers. Triodes for Alternating Current (TRIAC) used in dimmers require a minimum latching current when triggered to place the TRIAC in the latched-on state. Once latched, a minimum holding current is required to maintain the TRIAC in the on state. Latching current is many times greater than the holding current, and is the main concern with dimmer compatibility.

Higher latching current can be provided by a simple series RC network across the AC line. A short time constant provides a current spike at the turn-on edge.

Less common is inadequate holding current. The minimum dimmer holding current is typically 10-20mA. Tap1 at 60mA (max) exceeds the minimum.

FIGURE 3-3: PHASE DIMMING

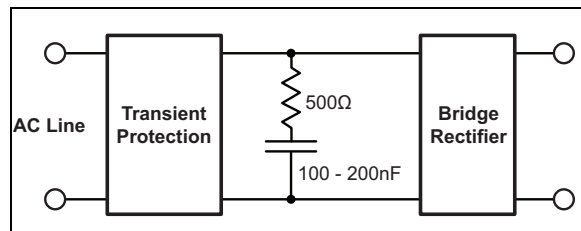

3.5 Strobing

Twice per AC line cycle the line voltage crosses zero volts, during which time there is no light output.

The circuit in [Figure 3-4](#) can provide 5-10% valley fill. It has little effect on input current wave shape (THD, PF) and efficiency.

This circuit is intended to prevent the output from reaching zero. It will not significantly reduce output ripple.

3.6 Power Boost

Higher output power can be achieved by off-loading a portion of the power dissipation from the CL8800 to external Field-Effect Transistors (FET). The circuit below drops most of the tap voltage across the FETs, thereby shifting the bulk of the dissipation to the FET.

FIGURE 3-4: POWER BOOST

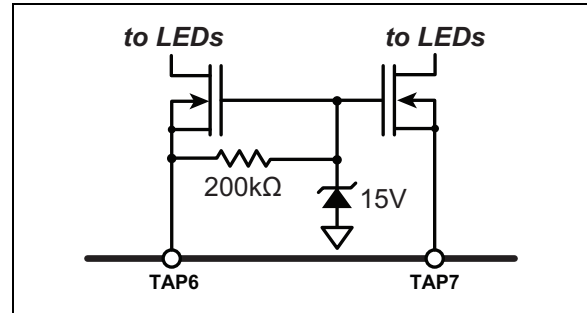
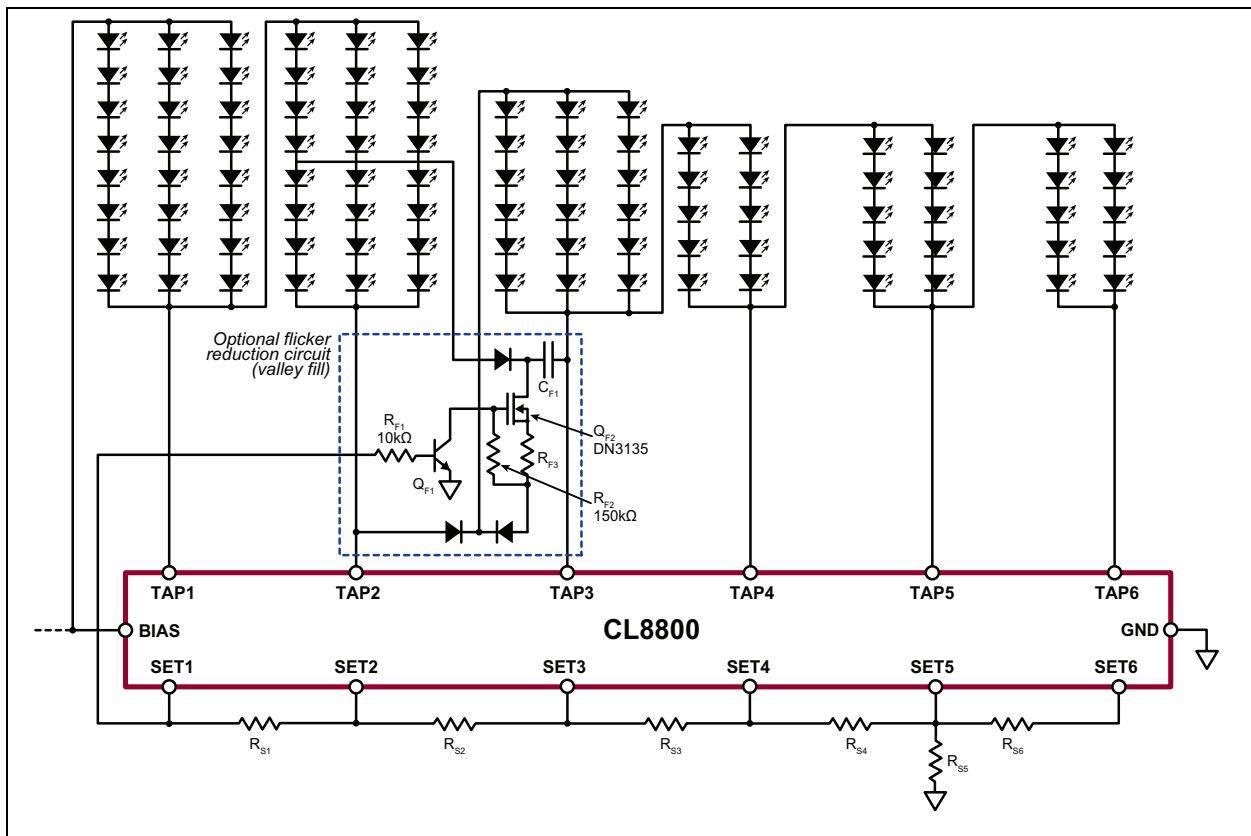
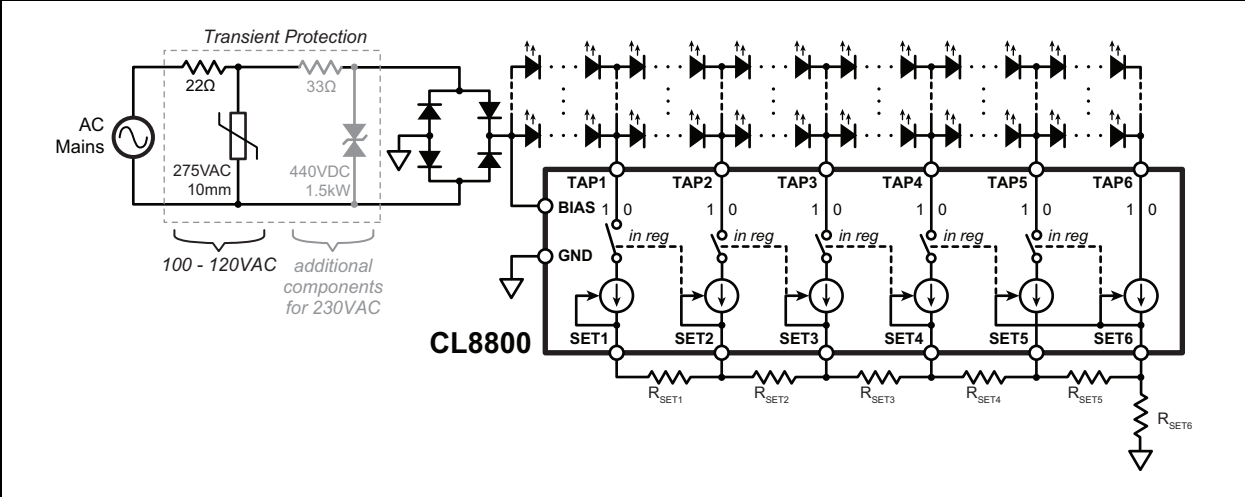

FIGURE 3-5: VALLEY FILL CIRCUIT



CL8800

FIGURE 3-6: SIMPLIFIED BLOCK DIAGRAM



4.0 PACKAGING INFORMATION

4.1 Package Marking Information

33-lead QFN

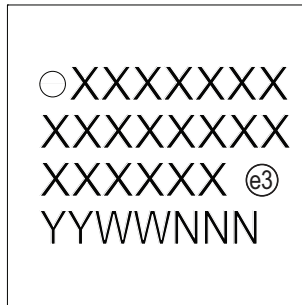

Example

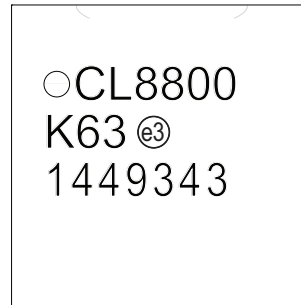

Legend:	XX...X	Product Code or Customer-specific information
	Y	Year code (last digit of calendar year)
	YY	Year code (last 2 digits of calendar year)
	WW	Week code (week of January 1 is week '01')
	NNN	Alphanumeric traceability code
	(e3)	Pb-free JEDEC® designator for Matte Tin (Sn)
	*	This package is Pb-free. The Pb-free JEDEC designator (e3) can be found on the outer packaging for this package.

Note: In the event the full Microchip part number cannot be marked on one line, it will be carried over to the next line, thus limiting the number of available characters for product code or customer-specific information. Package may or may not include the corporate logo.

33-Lead QFN Package Outline (K6)

6.00x6.00mm body, 1.00mm height (max), 0.50mm pitch

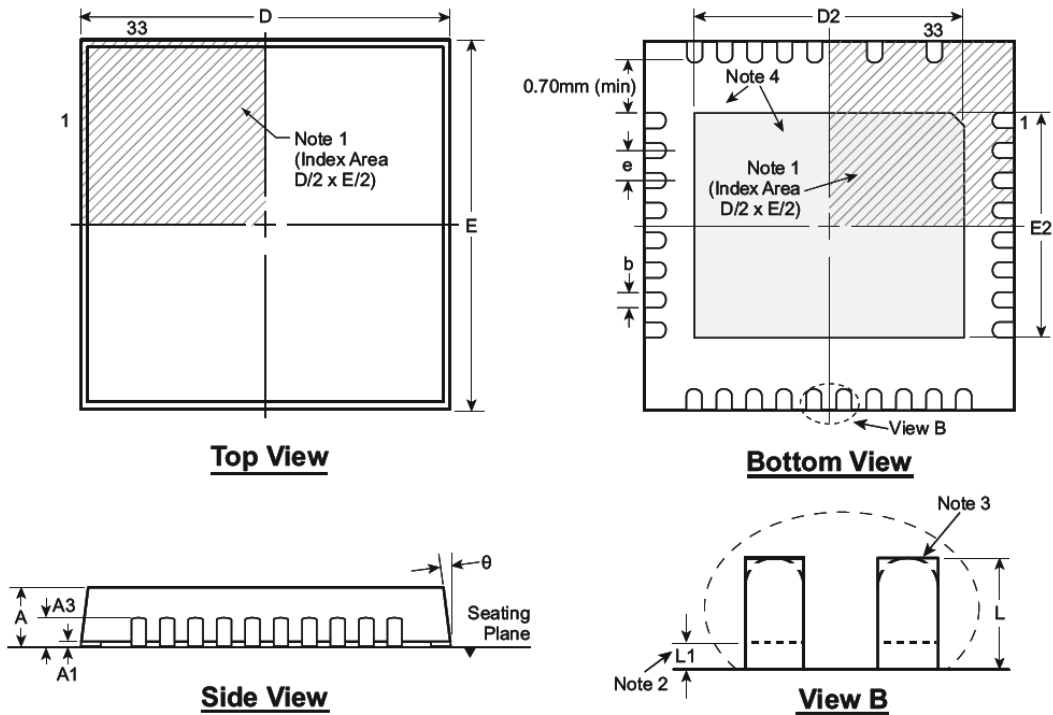

Note: For the most current package drawings, see the Microchip Packaging Specification at www.microchip.com/packaging.

Notes:

1. A Pin 1 identifier must be located in the index area indicated. The Pin 1 identifier can be: a molded mark/identifier; an embedded metal marker; or a printed indicator.
2. Depending on the method of manufacturing, a maximum of 0.15mm pullback (L1) may be present.
3. The inner tip of the lead may be either rounded or square.
4. There will be an exposed DAP. A minimum of 0.7mm spacing will be maintained between the leads and the DAP.

Symbol	A	A1	A3	b	D	D2	E	E2	e	L	L1	θ°	
Dimension (mm)	MIN	0.80	0.00	0.20 REF	0.18	5.85	4.00	5.85	3.60	0.50 BSC	0.30	0.00	0
	NOM	0.90	0.02		0.25	6.00	4.15	6.00	3.75		0.40	-	-
	MAX	1.00	0.05		0.30	6.15	4.25	6.15	3.85		0.50	0.15	14

Drawings not to scale.

APPENDIX A: REVISION HISTORY

Revision A (January 2015)

- Update file to new format

CL8800

PRODUCT IDENTIFICATION SYSTEM

To order or obtain information, e.g., on pricing or delivery, refer to the factory or the listed sales office.

<u>PART NO.</u>	<u>XX</u>	-	<u>X</u>	-	<u>X</u>
Device	Package Options		Environmental		Media Type
Device:	CL8800	=	Sequential Linear LED Driver		
Package:	K6(3)	=	QFN (6x6 mm body), 33-lead		
Environmental	G	=	Lead (Pb)-free/ROHS-compliant package		
Media Type:	(blank)	=	490/Tray		
	M935	=	3000/Reel		

Examples:

a) CL8800K63-G: 33-lead QFN package, 490/Tray.

b) CL8800K63-G-M935 33-lead QFN package, 3000/Reel

Note the following details of the code protection feature on Microchip devices:

- Microchip products meet the specification contained in their particular Microchip Data Sheet.
- Microchip believes that its family of products is one of the most secure families of its kind on the market today, when used in the intended manner and under normal conditions.
- There are dishonest and possibly illegal methods used to breach the code protection feature. All of these methods, to our knowledge, require using the Microchip products in a manner outside the operating specifications contained in Microchip's Data Sheets. Most likely, the person doing so is engaged in theft of intellectual property.
- Microchip is willing to work with the customer who is concerned about the integrity of their code.
- Neither Microchip nor any other semiconductor manufacturer can guarantee the security of their code. Code protection does not mean that we are guaranteeing the product as “unbreakable.”

Code protection is constantly evolving. We at Microchip are committed to continuously improving the code protection features of our products. Attempts to break Microchip's code protection feature may be a violation of the Digital Millennium Copyright Act. If such acts allow unauthorized access to your software or other copyrighted work, you may have a right to sue for relief under that Act.

Information contained in this publication regarding device applications and the like is provided only for your convenience and may be superseded by updates. It is your responsibility to ensure that your application meets with your specifications. MICROCHIP MAKES NO REPRESENTATIONS OR WARRANTIES OF ANY KIND WHETHER EXPRESS OR IMPLIED, WRITTEN OR ORAL, STATUTORY OR OTHERWISE, RELATED TO THE INFORMATION, INCLUDING BUT NOT LIMITED TO ITS CONDITION, QUALITY, PERFORMANCE, MERCHANTABILITY OR FITNESS FOR PURPOSE. Microchip disclaims all liability arising from this information and its use. Use of Microchip devices in life support and/or safety applications is entirely at the buyer's risk, and the buyer agrees to defend, indemnify and hold harmless Microchip from any and all damages, claims, suits, or expenses resulting from such use. No licenses are conveyed, implicitly or otherwise, under any Microchip intellectual property rights.

Trademarks

The Microchip name and logo, the Microchip logo, dsPIC, FlashFlex, KEELOQ, KEELOQ logo, MPLAB, PIC, PICmicro, PICSTART, PIC³² logo, rPIC, SST, SST Logo, SuperFlash and UNI/O are registered trademarks of Microchip Technology Incorporated in the U.S.A. and other countries.

FilterLab, Hampshire, HI-TECH C, Linear Active Thermistor, MTP, SEEVAL and The Embedded Control Solutions Company are registered trademarks of Microchip Technology Incorporated in the U.S.A.

Silicon Storage Technology is a registered trademark of Microchip Technology Inc. in other countries.

Analog-for-the-Digital Age, Application Maestro, BodyCom, chipKIT, chipKIT logo, CodeGuard, dsPICDEM, dsPICDEM.net, dsPICworks, dsSPEAK, ECAN, ECONOMONITOR, FanSense, HI-TIDE, In-Circuit Serial Programming, ICSP, Mindi, MiWi, MPASM, MPF, MPLAB Certified logo, MPLIB, MPLINK, mTouch, Omniclient Code Generation, PICC, PICC-18, PICDEM, PICDEM.net, PICkit, PICTail, REAL ICE, rFLAB, Select Mode, SQI, Serial Quad I/O, Total Endurance, TSHARC, UniWinDriver, WiperLock, ZENA and Z-Scale are trademarks of Microchip Technology Incorporated in the U.S.A. and other countries.

SQTP is a service mark of Microchip Technology Incorporated in the U.S.A.

GestIC and ULPP are registered trademarks of Microchip Technology Germany II GmbH & Co. KG, a subsidiary of Microchip Technology Inc., in other countries.

All other trademarks mentioned herein are property of their respective companies.

© 2015, Microchip Technology Incorporated, Printed in the U.S.A., All Rights Reserved.

 Printed on recycled paper.

ISBN: 978-1-63276-957-2

Microchip received ISO/TS-16949:2009 certification for its worldwide headquarters, design and wafer fabrication facilities in Chandler and Tempe, Arizona; Gresham, Oregon and design centers in California and India. The Company's quality system processes and procedures are for its PIC[®] MCUs and dsPIC[®] DSCs, KEELOQ[®] code hopping devices, Serial EEPROMs, microperipherals, nonvolatile memory and analog products. In addition, Microchip's quality system for the design and manufacture of development systems is ISO 9001:2000 certified.

**QUALITY MANAGEMENT SYSTEM
CERTIFIED BY DNV
= ISO/TS 16949 =**



MICROCHIP

Worldwide Sales and Service

AMERICAS

Corporate Office
2355 West Chandler Blvd.
Chandler, AZ 85224-6199
Tel: 480-792-7200
Fax: 480-792-7277
Technical Support:
<http://www.microchip.com/support>
Web Address:
www.microchip.com

Atlanta
Duluth, GA
Tel: 678-957-9614
Fax: 678-957-1455

Austin, TX
Tel: 512-257-3370

Boston
Westborough, MA
Tel: 774-760-0087
Fax: 774-760-0088

Chicago
Itasca, IL
Tel: 630-285-0071
Fax: 630-285-0075

Cleveland
Independence, OH
Tel: 216-447-0464
Fax: 216-447-0643

Dallas
Addison, TX
Tel: 972-818-7423
Fax: 972-818-2924

Detroit
Novi, MI
Tel: 248-848-4000

Houston, TX
Tel: 281-894-5983

Indianapolis
Noblesville, IN
Tel: 317-773-8323
Fax: 317-773-5453

Los Angeles
Mission Viejo, CA
Tel: 949-462-9523
Fax: 949-462-9608

New York, NY
Tel: 631-435-6000

San Jose, CA
Tel: 408-735-9110

Canada - Toronto
Tel: 905-673-0699
Fax: 905-673-6509

ASIA/PACIFIC

Asia Pacific Office
Suites 3707-14, 37th Floor
Tower 6, The Gateway
Harbour City, Kowloon
Hong Kong
Tel: 852-2943-5100
Fax: 852-2401-3431

Australia - Sydney
Tel: 61-2-9868-6733
Fax: 61-2-9868-6755

China - Beijing
Tel: 86-10-8569-7000
Fax: 86-10-8528-2104

China - Chengdu
Tel: 86-28-8665-5511
Fax: 86-28-8665-7889

China - Chongqing
Tel: 86-23-8980-9588
Fax: 86-23-8980-9500

China - Hangzhou
Tel: 86-571-8792-8115
Fax: 86-571-8792-8116

China - Hong Kong SAR
Tel: 852-2943-5100
Fax: 852-2401-3431

China - Nanjing
Tel: 86-25-8473-2460
Fax: 86-25-8473-2470

China - Qingdao
Tel: 86-532-8502-7355
Fax: 86-532-8502-7205

China - Shanghai
Tel: 86-21-5407-5533
Fax: 86-21-5407-5066

China - Shenyang
Tel: 86-24-2334-2829
Fax: 86-24-2334-2393

China - Shenzhen
Tel: 86-755-8864-2200
Fax: 86-755-8203-1760

China - Wuhan
Tel: 86-27-5980-5300
Fax: 86-27-5980-5118

China - Xian
Tel: 86-29-8833-7252
Fax: 86-29-8833-7256

China - Xiamen
Tel: 86-592-2388138
Fax: 86-592-2388130

China - Zhuhai
Tel: 86-756-3210040
Fax: 86-756-3210049

ASIA/PACIFIC

India - Bangalore
Tel: 91-80-3090-4444
Fax: 91-80-3090-4123

India - New Delhi
Tel: 91-11-4160-8631
Fax: 91-11-4160-8632

India - Pune
Tel: 91-20-3019-1500

Japan - Osaka
Tel: 81-6-6152-7160
Fax: 81-6-6152-9310

Japan - Tokyo
Tel: 81-3-6880-3770
Fax: 81-3-6880-3771

Korea - Daegu
Tel: 82-53-744-4301
Fax: 82-53-744-4302

Korea - Seoul
Tel: 82-2-554-7200
Fax: 82-2-558-5932 or
82-2-558-5934

Malaysia - Kuala Lumpur
Tel: 60-3-6201-9857
Fax: 60-3-6201-9859

Malaysia - Penang
Tel: 60-4-227-8870
Fax: 60-4-227-4068

Philippines - Manila
Tel: 63-2-634-9065
Fax: 63-2-634-9069

Singapore
Tel: 65-6334-8870
Fax: 65-6334-8850

Taiwan - Hsin Chu
Tel: 886-3-5778-366
Fax: 886-3-5770-955

Taiwan - Kaohsiung
Tel: 886-7-213-7830

Taiwan - Taipei
Tel: 886-2-2508-8600
Fax: 886-2-2508-0102

Thailand - Bangkok
Tel: 66-2-694-1351
Fax: 66-2-694-1350

EUROPE

Austria - Wels
Tel: 43-7242-2244-39
Fax: 43-7242-2244-393

Denmark - Copenhagen
Tel: 45-4450-2828
Fax: 45-4485-2829

France - Paris
Tel: 33-1-69-53-63-20
Fax: 33-1-69-30-90-79

Germany - Dusseldorf
Tel: 49-2129-3766400

Germany - Munich
Tel: 49-89-627-144-0
Fax: 49-89-627-144-44

Germany - Pforzheim
Tel: 49-7231-424750

Italy - Milan
Tel: 39-0331-742611
Fax: 39-0331-466781

Italy - Venice
Tel: 39-049-7625286

Netherlands - Drunen
Tel: 31-416-690399
Fax: 31-416-690340

Poland - Warsaw
Tel: 48-22-3325737

Spain - Madrid
Tel: 34-91-708-08-90
Fax: 34-91-708-08-91

Sweden - Stockholm
Tel: 46-8-5090-4654

UK - Wokingham
Tel: 44-118-921-5800
Fax: 44-118-921-5820

03/25/14

Looking for pricing, stock, or lifecycle information?

Click below to explore more details on WIN SOURCE:

- ⊖ [View CL8800K63-G on WIN SOURCE](#)
- ⊖ [Microchip Technology](#) Information

Optimize Your Supply Chain with WIN SOURCE Solutions

- ✓ Global Sourcing Solution
- ✓ Obsolete Management
- ✓ Cost Control Management
- ✓ Shortage Management
- ✓ Alternative Solution
- ✓ Excess Inventory Management