



**THE DATASHEET OF
TLV2543CDBRG4**



TLV2543C, TLV2543I
12-BIT ANALOG-TO-DIGITAL CONVERTERS
WITH SERIAL CONTROL AND 11 ANALOG INPUTS

SLAS096C – MARCH 1995 – REVISED JUNE 2000

functional block diagram

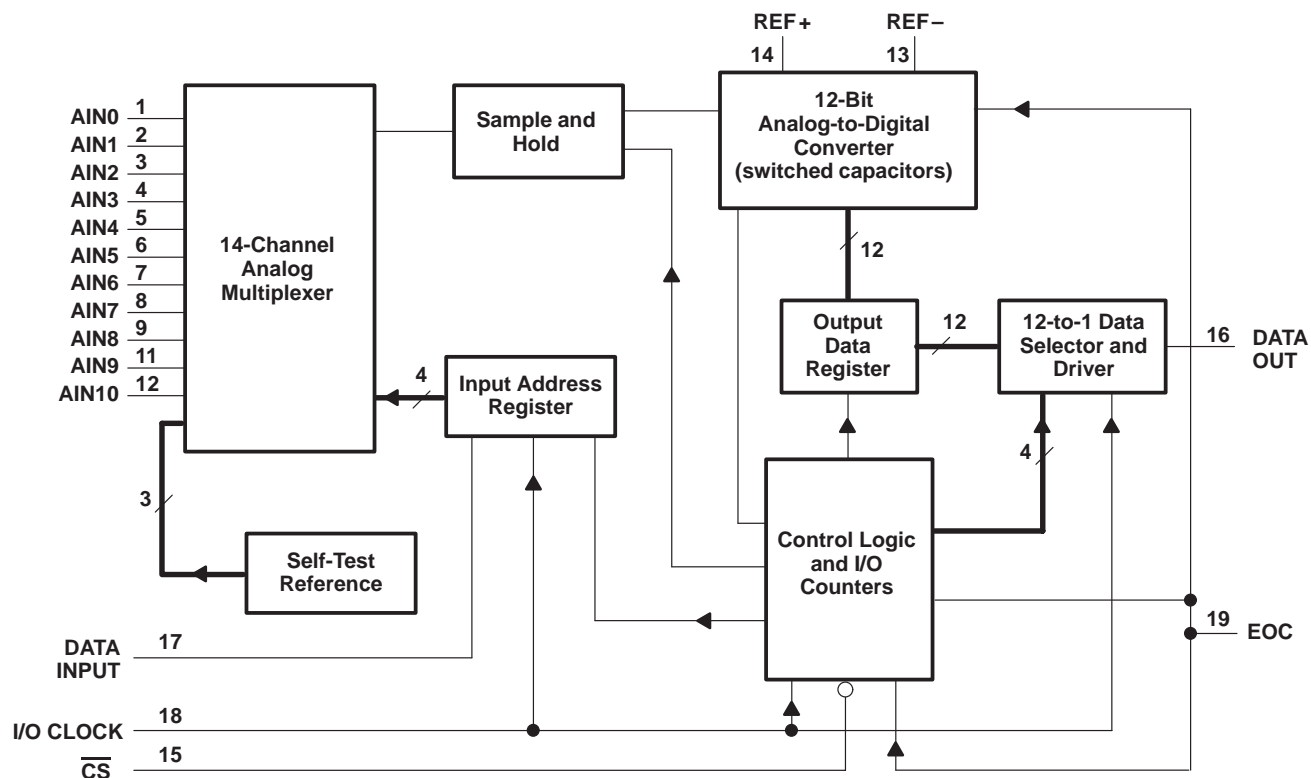

Terminal Functions

TERMINAL NAME	NO.	I/O	DESCRIPTION
AIN0 – AIN10	1–9, 11, 12	I	Analog input. These 11 analog-signal inputs are internally multiplexed. The driving source impedance should be less than or equal to 50 Ω for 4.1-MHz I/O CLOCK operation and capable of slewing the analog input voltage into a capacitance of 60 pF.
\overline{CS}	15	I	Chip select. A high-to-low transition on \overline{CS} resets the internal counters and controls and enables DATA OUT, DATA INPUT, and I/O CLOCK. A low-to-high transition disables DATA INPUT and I/O CLOCK within a setup time.
DATA INPUT	17	I	Serial-data input. A 4-bit serial address selects the desired analog input or test voltage to be converted. The serial data is presented with the MSB first and is shifted in on the first four rising edges of I/O CLOCK. After the four address bits are read into the address register, I/O CLOCK clocks the remaining bits in order.
DATA OUT	16	O	Serial data output. This is the 3-state serial output for the A/D conversion result. DATA OUT is in the high-impedance state when \overline{CS} is high and active when \overline{CS} is low. With a valid \overline{CS} , DATA OUT is removed from the high-impedance state and is driven to the logic level corresponding to the MSB/LSB value of the previous conversion result. The next falling edge of I/O CLOCK drives DATA OUT to the logic level corresponding to the next MSB/LSB, and the remaining bits are shifted out in order.
EOC	19	O	End of conversion. EOC goes from a high to a low logic level after the falling edge of the last I/O CLOCK and remains low until the conversion is complete and data are ready for transfer.
GND	10		Ground. This is the ground return terminal for the internal circuitry. Unless otherwise noted, all voltage measurements are with respect to GND.
I/O CLOCK	18	I	Input/output clock. I/O CLOCK receives the serial input and performs the following four functions: 1. It clocks the eight input data bits into the input data register on the first eight rising edges of I/O CLOCK with the multiplexer address available after the fourth rising edge. 2. On the fourth falling edge of I/O CLOCK, the analog input voltage on the selected multiplexer input begins charging the capacitor array and continues to do so until the last falling edge of I/O CLOCK. 3. It shifts the 11 remaining bits of the previous conversion data out on DATA OUT. Data changes on the falling edge of I/O CLOCK. 4. It transfers control of the conversion to the internal state controller on the falling edge of the last I/O CLOCK.
REF+	14	I	Reference+. The upper reference voltage value (nominally V_{CC}) is applied to REF+. The maximum input voltage range is determined by the difference between the voltage applied to this terminal and the voltage applied to the REF– terminal.
REF–	13	I	Reference–. The lower reference voltage value (nominally ground) is applied to REF–.
V_{CC}	20		Positive supply voltage.

detailed description

Initially, with chip select (\overline{CS}) high, I/O CLOCK and DATA INPUT are disabled and DATA OUT is in the high-impedance state. \overline{CS} , going low, begins the conversion sequence by enabling I/O CLOCK and DATA INPUT and removes DATA OUT from the high-impedance state.

The input data is an 8-bit data stream consisting of a 4-bit analog channel address (D7–D4), a 2-bit data length select (D3–D2), an output MSB or LSB first bit (D1), and a unipolar or bipolar output select bit (D0) that are applied to DATA INPUT. The I/O CLOCK sequence applied to the I/O CLOCK terminal transfers this data to the input data register.

During this transfer, the I/O CLOCK sequence also shifts the previous conversion result from the output data register to DATA OUT. I/O CLOCK receives the input sequence of 8, 12, or 16 clocks long depending on the data-length selection in the input data register. Sampling of the analog input begins on the fourth falling edge of the input I/O CLOCK sequence and is held after the last falling edge of the I/O CLOCK sequence. The last falling edge of the I/O CLOCK sequence also takes EOC low and begins the conversion.

TLV2543C, TLV2543I

12-BIT ANALOG-TO-DIGITAL CONVERTERS

WITH SERIAL CONTROL AND 11 ANALOG INPUTS

SLAS096C – MARCH 1995 – REVISED JUNE 2000

converter operation

The operation of the converter is organized as a succession of two distinct cycles: 1) the I/O cycle, and 2) the actual conversion cycle. The I/O cycle is defined by the externally provided I/O CLOCK and lasts 8, 12, or 16 clock periods depending on the selected output data length.

1. I/O cycle

During the I/O cycle, two operations take place simultaneously.

- a. An 8-bit data stream consisting of address and control information is provided to DATA INPUT. This data is shifted into the device on the rising edge of the first eight I/O CLOCKS. DATA INPUT is ignored after the first eight clocks during 12- or 16-clock I/O transfers.
- b. The data output with a length of 8, 12, or 16 bits is provided serially on DATA OUT. When \overline{CS} is held low, the first output data bit occurs on the rising edge of EOC. When \overline{CS} is negated between conversions, the first output data bit occurs on the falling edge of \overline{CS} . This data is the result of the previous conversion period, and after the first output data bit each succeeding bit is clocked out on the falling edge of each succeeding I/O CLOCK.

2. Conversion cycle

The conversion cycle is transparent to the user, and it is controlled by an internal clock synchronized to the I/O CLOCK. During the conversion period, the device performs a successive-approximation conversion on the analog input voltage. The EOC output goes low at the start of the conversion cycle and goes high when conversion is complete and the output data register is latched. A conversion cycle is started only after the I/O cycle is completed, which minimizes the influence of external digital noise on the accuracy of the conversion.

power up and initialization

After power up, \overline{CS} must be taken from high to low to begin an I/O cycle. EOC is initially high, and the input data register is set to all zeros. The contents of the output data register are random, and the first conversion result should be ignored. To initialize during operation, \overline{CS} is taken high and returned low to begin the next I/O cycle. The first conversion after the device has returned from the power-down state may not read accurately due to internal device settling.

operational terminology

Previous (N-1) conversion cycle	The conversion cycle prior to the current I/O cycle.
Current (N) I/O cycle	The entire I/O CLOCK sequence that transfers address and control data into the data register and clocks the digital result from the previous conversion cycle from DATA OUT. The last falling edge of the clock in the I/O CLOCK sequence signifies the end of the current I/O cycle.
Current (N) conversion cycle	Immediately after the current I/O cycle, the current conversion cycle starts. When the current conversion cycle is complete, the current conversion result is loaded into the output register.
Current (N) conversion result	The result of the current conversion cycle that is serially shifted out during the next I/O cycle.
Next (N+1) I/O cycle	The I/O cycle after the current conversion cycle.

Example: In the 12-bit mode, the result of the current conversion cycle is a 12-bit serial-data stream clocked out during the next I/O cycle. The current I/O cycle must be exactly 12 bits long to maintain synchronization, even when this corrupts the output data from the previous conversion. The current conversion begins immediately after the twelfth falling edge of the current I/O cycle.

data input

The data input is internally connected to an 8-bit serial-input address and control register. The register defines the operation of the converter and the output data length. The host provides the data word with the MSB first. Each data bit is clocked in on the rising edge of the I/O CLOCK sequence (see Table 1 for the data register format).



data input (continued)

Table 1. Input-Register Format

FUNCTION SELECT	INPUT DATA BYTE							
	ADDRESS BITS				L1	L0	LSBF	BIP
	D7 (MSB)	D6	D5	D4	D3	D2	D1	D0 (LSB)
Select input channel								
AIN0 _____	0	0	0	0				
AIN1 _____	0	0	0	1				
AIN2 _____	0	0	1	0				
AIN3 _____	0	0	1	1				
AIN4 _____	0	1	0	0				
AIN5 _____	0	1	0	1				
AIN6 _____	0	1	1	0				
AIN7 _____	0	1	1	1				
AIN8 _____	1	0	0	0				
AIN9 _____	1	0	0	1				
AIN10 _____	1	0	1	0				
Select test voltage								
(V _{ref+} – V _{ref-})/2 _____	1	0	1	1				
V _{ref-} _____	1	1	0	0				
V _{ref+} _____	1	1	0	1				
Software power down _____	1	1	1	0				
Output data length								
8 bits _____					0	1		
12 bits _____					X	0		
16 bits _____					1	1		
Output data format								
MSB first _____							0	
LSB first _____							1	
Unipolar (binary) _____								0
Bipolar (BIP, 2s complement) _____								1

data input address bits

The four MSBs (D7 – D4) of the data register address one of the 11 input channels, a reference-test voltage, or the power-down mode. The address bits affect the current conversion, which is the conversion that immediately follows the current I/O cycle. The reference voltage is nominally equal to V_{ref+} – V_{ref-}.

data output length

The next two bits (D3 and D2) of the data register select the output data length. The data-length selection is valid for the current I/O cycle (the cycle in which the data is read). The data-length selection, which is valid for the current I/O cycle, allows device start-up without losing I/O synchronization. A data length of 8, 12, or 16 bits can be selected. Since the converter has 12-bit resolution, a data length of 12 bits is suggested.

With D3 and D2 set to 00 or 10, the device is in the 12-bit data-length mode and the result of the current conversion is output as a 12-bit serial-data stream during the next I/O cycle. The current I/O cycle must be exactly 12 bits long for proper synchronization, even when this means corrupting the output data from a previous conversion. The current conversion is started immediately after the twelfth falling edge of the current I/O cycle.

With bits D3 and D2 set to 11, the 16-bit data-length mode is selected, which allows convenient communication with 16-bit serial interfaces. In the 16-bit mode, the result of the current conversion is output as a 16-bit serial-data stream during the next I/O cycle with the four LSBs always set to 0 (pad bits). The current I/O cycle must be exactly 16 bits long to maintain synchronization even when this means corrupting the output data from the previous conversion. The current conversion is started immediately after the sixteenth falling edge of the current I/O cycle.



TLV2543C, TLV2543I

12-BIT ANALOG-TO-DIGITAL CONVERTERS

WITH SERIAL CONTROL AND 11 ANALOG INPUTS

SLAS096C – MARCH 1995 – REVISED JUNE 2000

data output length (continued)

With bits D3 and D2 set to 01, the 8-bit data-length mode is selected, which allows fast communication with 8-bit serial interfaces. In the 8-bit mode, the result of the current conversion is output as an 8-bit serial-data stream during the next I/O cycle. The current I/O cycle must be exactly 8 bits long to maintain synchronization, even when this means corrupting the output data from the previous conversion. The four LSBs of the conversion result are truncated and discarded. The current conversion is immediately started after the eighth falling edge of the current I/O cycle.

Since D3 and D2 take effect on the current I/O cycle when the data length is programmed, there can be a conflict with the previous cycle when the data-word length is changed from one cycle to the next. This may occur when the data format is selected to be least significant bit first, since at the time the data length change becomes effective (six rising edges of I/O CLOCK), the previous conversion result has already started shifting out.

In actual operation, when different data lengths are required within an application and the data length is changed between two conversions, no more than one conversion result can be corrupted and only when it is shifted out in LSB first format.

sampling period

During the sampling period, one of the analog inputs is internally connected to the capacitor array of the converter to store the analog input signal. The converter starts sampling the selected input immediately after the four address bits have been clocked into the input data register. Sampling starts on the fourth falling edge of I/O CLOCK. The converter remains in the sampling mode until the eighth, twelfth, or sixteenth falling edge of the I/O CLOCK depending on the data-length selection. After the EOC delay time from the last I/O CLOCK falling edge, the EOC output goes low indicating that the sampling period is over and the conversion period has begun. After EOC goes low, the analog input can be changed without affecting the conversion result. Since the delay from the falling edge of the last I/O CLOCK to EOC low is fixed, time-varying analog input signals can be digitized at a fixed rate without introducing systematic harmonic distortion or noise due to timing uncertainty.

After the 8-bit data stream has been clocked in, DATA INPUT should be held at a fixed digital level until EOC goes high (indicating that the conversion is complete) to maximize the sampling accuracy and minimize the influence of external digital noise.

data register, LSB first

D1 in the input data register (LSB first) controls the direction of the output binary data transfer. When D1 is set to 0, the conversion result shifts out MSB first. When set to 1, the data shifts out LSB first. Selection of MSB first or LSB first always affects the next I/O cycle and not the current I/O cycle. When changing from one data direction to another, the current I/O cycle is never disrupted.

data register, bipolar format

D0 in the input data register controls the binary data format used to represent the conversion result. When D0 is set to 0, the conversion result is represented as unipolar (unsigned binary) data. Nominally, the conversion result of an input voltage equal to V_{ref-} is a code of all zeros (000 . . . 0), the conversion result of an input voltage equal to V_{ref+} is a code of all ones (111 . . . 1), and the conversion result of $(V_{ref+} + V_{ref-})/2$ is a code of a one followed by zeros (100 . . . 0).

When D0 is set to 1, the conversion result is represented as bipolar data (signed binary). Nominally, conversion of an input voltage equal to V_{ref-} is a code of a 1 followed by zeros (100 . . . 0), conversion of an input voltage equal to V_{ref+} is a code of a 0 followed by all ones (011 . . . 1), and the conversion of $(V_{ref+} + V_{ref-})/2$ is a code of all zeros (000 . . . 0). The MSB is interpreted as the sign bit. The bipolar data format is related to the unipolar format in that the MSBs are always each other's complement.

Selection of the unipolar or bipolar format always affects the current conversion cycle, and the result is output during the next I/O cycle. When changing between unipolar and bipolar formats, the data output during the current I/O cycle is not affected.



EOC output

The EOC signal indicates the beginning and the end of conversion. In the reset state, EOC is always high. During the sampling period (beginning after the fourth falling edge of the I/O CLOCK sequence), EOC remains high until the internal sampling switch of the converter is safely opened. The opening of the sampling switch occurs after the eighth, twelfth, or sixteenth I/O CLOCK falling edge, depending on the data-length selection in the input data register. After the EOC signal goes low, the analog input signal can be changed without affecting the conversion result.

The EOC signal goes high again after the conversion completes and the conversion result is latched into the output data register. The rising edge of EOC returns the converter to a reset state and a new I/O cycle begins. On the rising edge of EOC, the first bit of the current conversion result is on DATA OUT when \overline{CS} is low. When \overline{CS} is negated between conversions, the first bit of the current conversion result occurs at DATA OUT on the falling edge of \overline{CS} .

data format and pad bits

D3 and D2 of the input data register determine the number of significant bits in the digital output that represent the conversion result. The LSB-first bit determines the direction of the data transfer while the BIP bit determines the arithmetic conversion. The numerical data is always justified toward the MSB in any output format.

The internal conversion result is always 12 bits long. When an 8-bit data transfer is selected, the four LSBs of the internal result are discarded to provide a faster one-byte transfer. When a 12-bit transfer is used, all bits are transferred. When a 16-bit transfer is used, four LSB pad bits are always appended to the internal conversion result. In the LSB-first mode, four leading zeros are output. In the MSB-first mode, the last four bits output are zeros.

When \overline{CS} is held low continuously, the first data bit of the just completed conversion occurs on DATA OUT on the rising edge of EOC. When a new conversion is started after the last falling edge of I/O CLOCK, EOC goes low and the serial output is forced to a logic zero until EOC goes high again.

When \overline{CS} is negated between conversions, the first data bit occurs on DATA OUT on the falling edge of \overline{CS} . On each subsequent falling edge of I/O CLOCK after the first data bit appears, the data is changed to the next bit in the serial conversion result until the required number of bits has been output.

chip-select input (\overline{CS})

The chip-select input (\overline{CS}) enables and disables the device. During normal operation, \overline{CS} should be low. Although the use of \overline{CS} is not necessary to synchronize a data transfer, it can be brought high between conversions to coordinate the data transfer of several devices sharing the same bus.

When \overline{CS} is brought high, the serial-data output is immediately brought to the high-impedance state, releasing its output data line to other devices that may share it. After an internally generated debounce time, the I/O CLOCK is inhibited, thus preventing any further change in the internal state.

When \overline{CS} is subsequently brought low again, the device is reset. \overline{CS} must be held low for an internal debounce time before the reset operation takes effect. After \overline{CS} is debounced low, I/O CLOCK must remain inactive (low) for a minimum time before a new I/O cycle can start.

\overline{CS} can be used to interrupt any ongoing data transfer or any ongoing conversion. When \overline{CS} is debounced low long enough before the end of the current conversion cycle, the previous conversion result is saved in the internal output buffer and then shifted out during the next I/O cycle.

TLV2543C, TLV2543I

12-BIT ANALOG-TO-DIGITAL CONVERTERS

WITH SERIAL CONTROL AND 11 ANALOG INPUTS

SLAS096C – MARCH 1995 – REVISED JUNE 2000

power-down features

When a binary address of 1110 is clocked into the input data register during the first four I/O CLOCK cycles, the power-down mode is selected. Power down is activated on the falling edge of the fourth I/O CLOCK pulse.

During power down, all internal circuitry is put in a low-current standby mode. No conversions are performed, and the internal output buffer keeps the previous conversion cycle data results, provided that all digital inputs are held above $V_{CC} - 0.3\text{ V}$ or below 0.3 V . The I/O logic remains active so the current I/O cycle must be completed even when the power-down mode is selected. Upon power-on reset and before the first I/O cycle, the converter normally begins in the power-down mode. The device remains in the power-down mode until a valid (other than 1110) input address clocks in. Upon completion of that I/O cycle, a normal conversion is performed with the results being shifted out during the next I/O cycle.

analog input, test, and power-down mode

The 11 analog inputs, three internal voltages, and power-down mode are selected by the input multiplexer according to the input addresses shown in Tables 2, 3, and 4. The input multiplexer is a break-before-make type to reduce input-to-input noise rejection resulting from channel switching. Sampling of the analog input starts on the falling edge of the fourth I/O CLOCK and continues for the remaining I/O CLOCK pulses. The sample is held on the falling edge of the last I/O CLOCK pulse. The three internal test inputs are applied to the multiplexer, sampled, and converted in the same manner as the external analog inputs. The first conversion after the device has returned from the power-down state may not read accurately due to internal device settling.

Table 2. Analog-Channel-Select Address

ANALOG INPUT SELECTED	VALUE SHIFTED INTO DATA INPUT	
	BINARY	HEX
AIN0	0000	0
AIN1	0001	1
AIN2	0010	2
AIN3	0011	3
AIN4	0100	4
AIN5	0101	5
AIN6	0110	6
AIN7	0111	7
AIN8	1000	8
AIN9	1001	9
AIN10	1010	A

Table 3. Test-Mode-Select Address

INTERNAL SELF-TEST VOLTAGE SELECTED†	VALUE SHIFTED INTO DATA INPUT		UNIPOLAR OUTPUT RESULT (HEX)‡
	BINARY	HEX	
$\frac{V_{ref+} - V_{ref-}}{2}$	1011	B	200
V_{ref-}	1100	C	000
V_{ref+}	1101	D	3FF

† V_{ref+} is the voltage applied to REF+, and V_{ref-} is the voltage applied to REF-.

‡ The output results shown are the ideal values and may vary with the reference stability and with internal offsets.



analog input, test, and power-down mode (continued)

Table 4. Power-Down-Select Address

INPUT COMMAND	VALUE SHIFTED INTO DATA INPUT		RESULT
	BINARY	HEX	
Power down	1110	E	$I_{CC} \leq 25 \mu A$

converter and analog input

The CMOS threshold detector in the successive-approximation conversion system determines each bit by examining the charge on a series of binary-weighted capacitors (see Figure 1). In the first phase of the conversion process, the analog input is sampled by closing the S_C switch and all S_T switches simultaneously. This action charges all the capacitors to the input voltage.

In the next phase of the conversion process, all S_T and S_C switches are opened and the threshold detector begins identifying bits by identifying the charge (voltage) on each capacitor relative to the reference (REF-) voltage. In the switching sequence, 12 capacitors are examined separately until all 12 bits are identified and the charge-convert sequence is repeated. In the first step of the conversion phase, the threshold detector looks at the first capacitor (weight = 4096). Node 4096 of this capacitor is switched to the REF+ voltage, and the equivalent nodes of all the other capacitors on the ladder are switched to REF-. When the voltage at the summing node is greater than the trip point of the threshold detector (approximately one-half V_{CC}), a bit 0 is placed in the output register and the 4096-weight capacitor is switched to REF-. When the voltage at the summing node is less than the trip point of the threshold detector, a bit 1 is placed in the register and the 4096-weight capacitor remains connected to REF+ through the remainder of the successive-approximation process. The process is repeated for the 2048-weight capacitor, the 1024-weight capacitor, and so forth down the line until all bits are determined. With each step of the successive-approximation process, the initial charge is redistributed among the capacitors. The conversion process relies on charge redistribution to determine the bits from MSB to LSB.

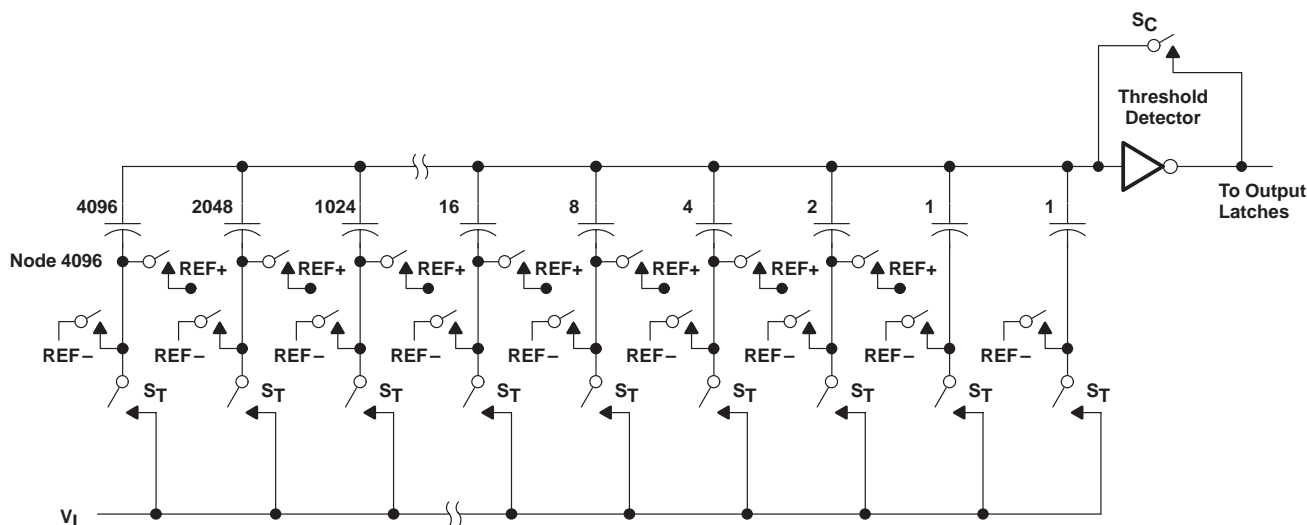

Figure 1. Simplified Model of the Successive-Approximation System

TLV2543C, TLV2543I
12-BIT ANALOG-TO-DIGITAL CONVERTERS
WITH SERIAL CONTROL AND 11 ANALOG INPUTS

SLAS096C – MARCH 1995 – REVISED JUNE 2000

reference voltage inputs

There are two reference voltage inputs on the device, REF+ and REF-. The voltage values on these terminals establish the upper and lower limits of the analog input to produce a full-scale and zero-scale reading respectively. These voltages and the analog input should not exceed the positive supply or be lower than ground consistent with the specified absolute maximum ratings. The digital output is at full scale when the input signal is equal to or higher than REF+ terminal voltage and at zero when the input signal is equal to or lower than REF- terminal voltage.

absolute maximum ratings over operating free-air temperature range (unless otherwise noted)†

Supply voltage range, V_{CC} (see Note 1)	-0.5 V to 6.5 V
Input voltage range, V_I (any input)	-0.3 V to $V_{CC} + 0.3$ V
Output voltage range, V_O	-0.3 V to $V_{CC} + 0.3$ V
Positive reference voltage, V_{ref+}	$V_{CC} + 0.1$ V
Negative reference voltage, V_{ref-}	-0.1 V
Peak input current, I_I (any input)	± 20 mA
Peak total input current (all inputs)	± 30 mA
Operating free-air temperature range, T_A :	TLV2543C 0°C to 70°C
	TLV2543I -40°C to 85°C
Storage temperature range, T_{stg}	-65°C to 150°C
Lead temperature 1,6 mm (1/16 inch) from the case for 10 seconds	260°C

† Stresses beyond those listed under “absolute maximum ratings” may cause permanent damage to the device. These are stress ratings only, and functional operation of the device at these or any other conditions beyond those indicated under “recommended operating conditions” is not implied. Exposure to absolute-maximum-rated conditions for extended periods may affect device reliability.

NOTE 1: All voltage values are with respect to the GND terminal with REF- and GND wired together (unless otherwise noted).



TLV2543C, TLV2543I
12-BIT ANALOG-TO-DIGITAL CONVERTERS
WITH SERIAL CONTROL AND 11 ANALOG INPUTS

SLAS096C – MARCH 1995 – REVISED JUNE 2000

recommended operating conditions

		MIN	NOM	MAX	UNIT
Supply voltage, V_{CC}		3	3.3	3.6	V
Positive reference voltage, V_{ref+} (see Note 2)		V_{CC}			V
Negative reference voltage, V_{ref-} (see Note 2)		0			V
Differential reference voltage, $V_{ref+} - V_{ref-}$ (see Note 2)		2.5	V_{CC}	$V_{CC}+0.1$	V
Analog input voltage (see Note 2)		0			V_{CC}
High-level control input voltage, V_{IH}	$V_{CC} = 3\text{ V to }3.6\text{ V}$	2.1			V
Low-level control input voltage, V_{IL}	$V_{CC} = 3\text{ V to }3.6\text{ V}$	0.6			V
Clock frequency at I/O CLOCK		0	3	4.1	MHz
Setup time, address bits at DATA INPUT before I/O CLOCK \uparrow , $t_{su(A)}$ (see Figure 5)		100			ns
Hold time, address bits at DATA INPUT after I/O CLOCK \uparrow , $t_h(A)$ (see Figure 5)		0			ns
Hold time, \overline{CS} low after last I/O CLOCK \downarrow , $t_h(\overline{CS})$ (see Figure 6)		0			ns
Setup time, \overline{CS} low before clocking in first address bit, $t_{su}(\overline{CS})$ (see Note 3 and Figure 6)		1.425			μs
Pulse duration, I/O CLOCK high, $t_{wH(I/O)}$		190			ns
Pulse duration, I/O CLOCK low, $t_{wL(I/O)}$		190			ns
Transition time, I/O CLOCK, $t_t(I/O)$ (see Note 4 and Figure 7)		1			μs
Transition time, DATA INPUT and \overline{CS} , $t_t(\overline{CS})$		10			μs
Operating free-air temperature, T_A	TLV2543C	0			$^{\circ}\text{C}$
	TLV2543I	-40			
		70			
		85			

- NOTES: 2. Analog input voltages greater than the voltage applied to REF+ convert as all ones (111111111111), while input voltages less than the voltage applied to REF- convert as all zeros (000000000000).
3. To minimize errors caused by noise at the \overline{CS} input, the internal circuitry waits for a setup time after $\overline{CS}\downarrow$ before responding to control input signals. No attempt should be made to clock in an address until the minimum \overline{CS} setup time elapses.
4. This is the time required for the clock input signal to fall from V_{IHmin} to V_{ILmax} or to rise from V_{ILmax} to V_{IHmin} . In the vicinity of normal room temperature, the devices function with input clock transition time as slow as 1 μs for remote data acquisition applications where the sensor and the A/D converter are placed several feet away from the controlling microprocessor.



TLV2543C, TLV2543I
12-BIT ANALOG-TO-DIGITAL CONVERTERS
WITH SERIAL CONTROL AND 11 ANALOG INPUTS

SLAS096C – MARCH 1995 – REVISED JUNE 2000

**electrical characteristics over recommended operating free-air temperature range,
 $V_{CC} = V_{ref+} = 3\text{ V to }3.6\text{ V}$ (unless otherwise noted)**

PARAMETER		TEST CONDITIONS	MIN	TYP†	MAX	UNIT
VOH	High-level output voltage	$V_{CC} = 3\text{ V}, I_{OH} = -0.2\text{ mA}$	2.4			V
		$V_{CC} = 3\text{ V to }3.6\text{ V}, I_{OH} = -20\text{ }\mu\text{A}$	$V_{CC} - 0.1$			
VOL	Low-level output voltage	$V_{CC} = 3\text{ V}, I_{OL} = 0.8\text{ mA}$			0.4	V
		$V_{CC} = 3\text{ V to }3.6\text{ V}, I_{OL} = 20\text{ }\mu\text{A}$	0.1			
IOZ	Off-state (high-impedance-state) output current	$V_O = V_{CC}, \overline{CS}$ at V_{CC}		1	2.5	μA
		$V_O = 0, \overline{CS}$ at V_{CC}		1	-2.5	
I _{IH}	High-level input current	$V_I = V_{CC}$		1	2.5	μA
I _{IL}	Low-level input current	$V_I = 0$		1	-2.5	μA
I _{CC}	Operating supply current	\overline{CS} at 0 V		1	2.5	mA
I _{CC(PD)}	Power-down current	For all digital inputs, $0 \leq V_I \leq 0.3\text{ V}$ or $V_I \geq V_{CC} - 0.3\text{ V}$		4	25	μA
I _{lkg}	Selected channel leakage current	Selected channel at V_{CC} , Unselected channel at 0 V			1	μA
		Selected channel at 0 V, Unselected channel at V_{CC}			-1	
	Maximum static analog reference current into REF+	$V_{ref+} = V_{CC}, V_{ref-} = \text{GND}$		1	2.5	μA
C _i	Input capacitance	Analog inputs		30	60	pF
		Control inputs		5	15	

† All typical values are at $V_{CC} = 5\text{ V}, T_A = 25^\circ\text{C}$.



TLV2543C, TLV2543I
**12-BIT ANALOG-TO-DIGITAL CONVERTERS
 WITH SERIAL CONTROL AND 11 ANALOG INPUTS**

SLAS096C – MARCH 1995 – REVISED JUNE 2000

**operating characteristics over recommended operating free-air temperature range,
 $V_{CC} = V_{ref+} = 3\text{ V to }3.6\text{ V}$, I/O CLOCK frequency = 4.1 MHz, (unless otherwise noted)**

PARAMETER	TEST CONDITIONS	MIN	TYP†	MAX	UNIT
E_L	Linearity error (see Note 6)			±1	LSB
E_D	Differential linearity error			±1	LSB
E_O	Offset error (see Note 7)			±1.5	LSB
E_G	Gain error (see Note 7)			±1	LSB
E_T	Total unadjusted error (see Note 8)			±1.75	LSB
Self-test output code (see Table 3 and Note 9)	DATA INPUT = 1011	2038	2048	2058	
	DATA INPUT = 1100		0	10	
	DATA INPUT = 1101	4075	4095		
$t_{(conv)}$	Conversion time		8	10	μs
t_c	Total cycle time (access, sample, and conversion)			10 + total I/O CLOCK periods + $t_d(I/O\text{-}EOC)$	μs
t_{acq}	Channel acquisition time (sample)		4	12	I/O CLOCK periods
t_v	Valid time, DATA OUT remains valid after I/O CLOCK↓		10		ns
$t_d(I/O\text{-}DATA)$	Delay time, I/O CLOCK↓ to DATA OUT valid			250	ns
$t_d(I/O\text{-}EOC)$	Delay time, last I/O CLOCK↓ to EOC↓		1.5	2.2	μs
$t_d(EOC\text{-}DATA)$	Delay time, EOC↑ to DATA OUT (MSB/LSB)			200	ns
t_{PZH} , t_{PZL}	Enable time, \overline{CS} ↓ to DATA OUT (MSB/LSB driven)		0.7	1.3	μs
t_{PHZ} , t_{PLZ}	Disable time, \overline{CS} ↑ to DATA OUT (high impedance)		70	150	ns
$t_r(EOC)$	Rise time, EOC		15	50	ns
$t_f(EOC)$	Fall time, EOC		15	50	ns
$t_r(\text{bus})$	Rise time, data bus		15	50	ns
$t_f(\text{bus})$	Fall time, data bus		15	50	ns
$t_d(I/O\text{-}CS)$	Delay time, last I/O CLOCK↓ to \overline{CS} ↓ to abort conversion (see Note 11)			5	μs

† All typical values are at $T_A = 25^\circ\text{C}$.

- NOTES:
2. Analog input voltages greater than that applied to REF+ convert as all ones (11111111111), while input voltages less than that applied to REF- convert as all zeros (00000000000).
 6. Linearity error is the maximum deviation from the best straight line through the A/D transfer characteristics.
 7. Gain error is the difference between the actual midstep value and the nominal midstep value in the transfer diagram at the specified gain point after the offset error has been adjusted to zero. Offset error is the difference between the actual midstep value and the nominal midstep value at the offset point.
 8. Total unadjusted error comprises linearity, zero-scale, and full-scale errors.
 9. Both the input address and the output codes are expressed in positive logic.
 10. I/O CLOCK period = 1/(I/O CLOCK frequency) (see Figure 7).
 11. Any transitions of \overline{CS} are recognized as valid only when the level is maintained for a setup time. \overline{CS} must be taken low at $\leq 5\ \mu\text{s}$ of the tenth I/O CLOCK falling edge to ensure that a conversion is aborted. Between 5 μs and 10 μs, the result is uncertain as to whether the conversion is aborted or the conversion results are valid.



TLV2543C, TLV2543I
12-BIT ANALOG-TO-DIGITAL CONVERTERS
WITH SERIAL CONTROL AND 11 ANALOG INPUTS

SLAS096C – MARCH 1995 – REVISED JUNE 2000

PARAMETER MEASUREMENT INFORMATION

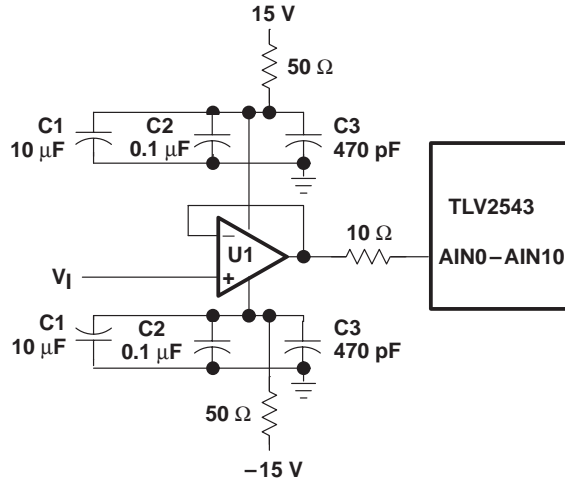

LOCATION	DESCRIPTION	PART NUMBER
U1	OP27	—
C1	10-μF 35-V tantalum capacitor	—
C2	0.1-μF ceramic NPO SMD capacitor	AVX 12105C104KA105 or equivalent
C3	470-pF porcelain high-Q SMD capacitor	Johanson 201S420471JG4L or equivalent

Figure 2. Analog Input Buffer to Analog Inputs AIN0–AIN10

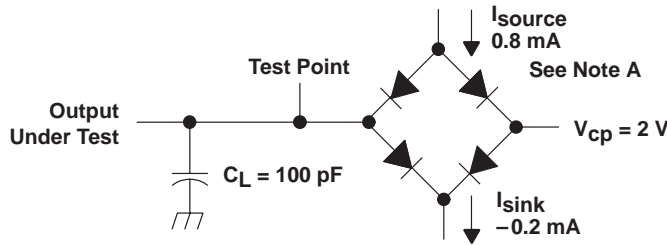

NOTE A: Equivalent load circuit of the Teradyne A580 tester for timing parameter measurement.

Figure 3. Timing Load Circuits

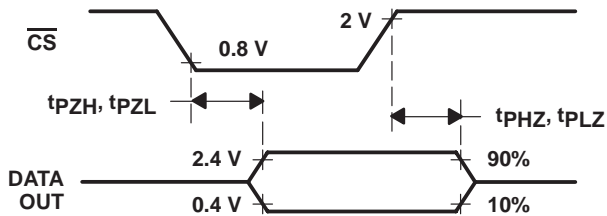

Figure 4. DATA OUT to Hi-Z Voltage Waveforms

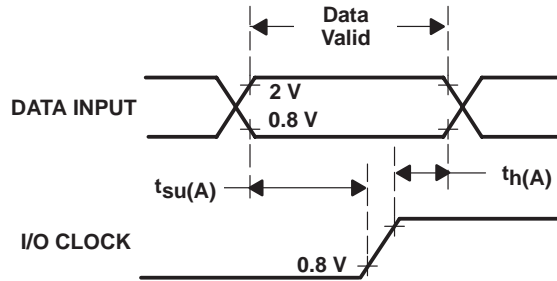

Figure 5. DATA INPUT and I/O CLOCK Voltage Waveforms

PARAMETER MEASUREMENT INFORMATION

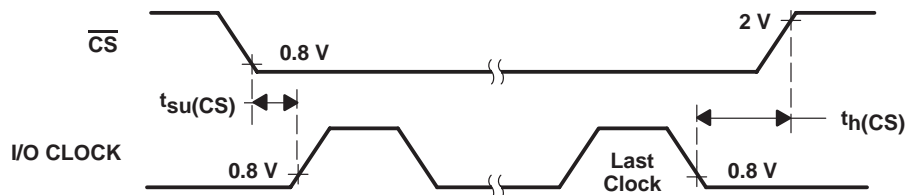

Figure 6. \overline{CS} and I/O CLOCK Voltage Waveforms†

† To ensure full conversion accuracy, it is recommended that no input signal change occurs while a conversion is ongoing.

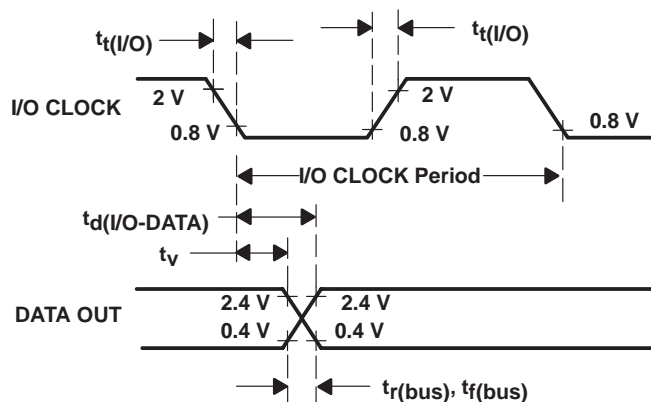

Figure 7. I/O CLOCK and DATA OUT Voltage Waveforms

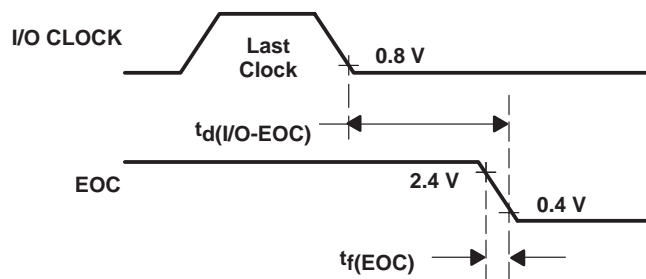

Figure 8. I/O CLOCK and EOC Voltage Waveforms

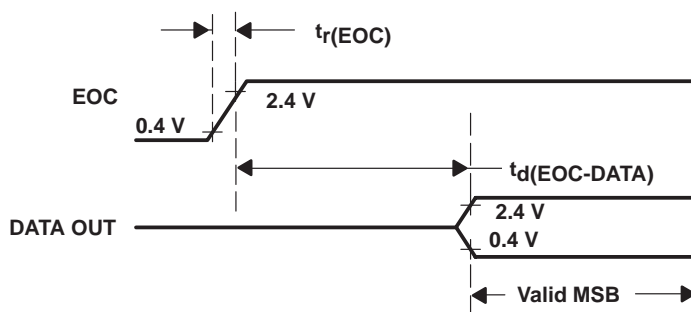

Figure 9. EOC and DATA OUT Voltage Waveforms

TLV2543C, TLV2543I
12-BIT ANALOG-TO-DIGITAL CONVERTERS
WITH SERIAL CONTROL AND 11 ANALOG INPUTS

SLAS096C – MARCH 1995 – REVISED JUNE 2000

PARAMETER MEASUREMENT INFORMATION

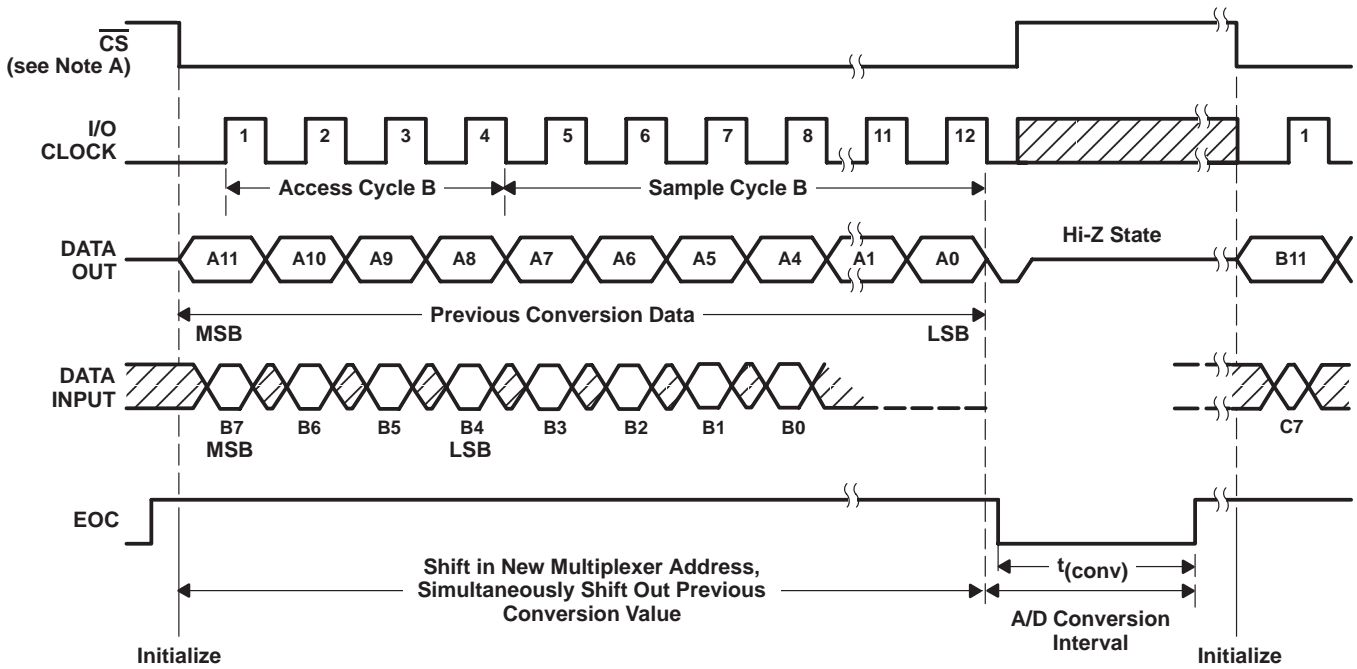

Figure 10. Timing for 12-Clock Transfer Using \overline{CS} With MSB First

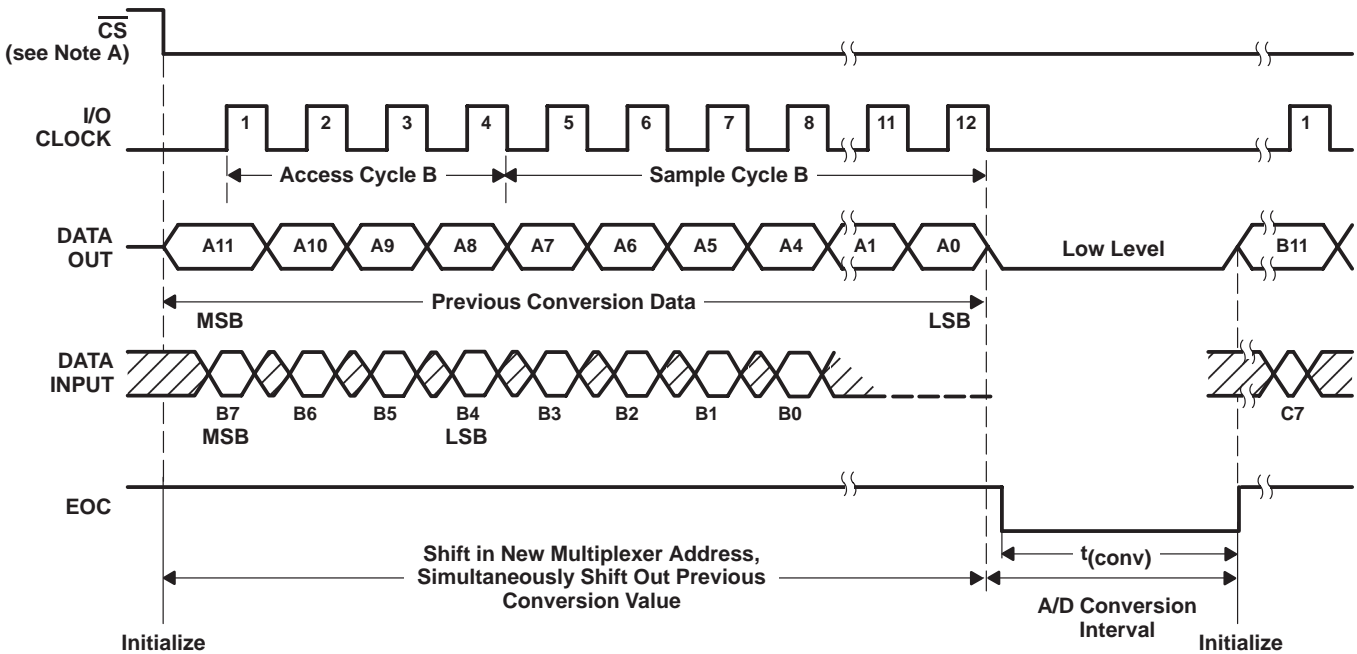

Figure 11. Timing for 12-Clock Transfer Not Using \overline{CS} With MSB First

NOTE A: To minimize errors caused by noise at \overline{CS} , the internal circuitry waits for a setup time after $\overline{CS}\downarrow$ before responding to control input signals. Therefore, no attempt should be made to clock in an address until the minimum \overline{CS} setup time has elapsed.



PARAMETER MEASUREMENT INFORMATION

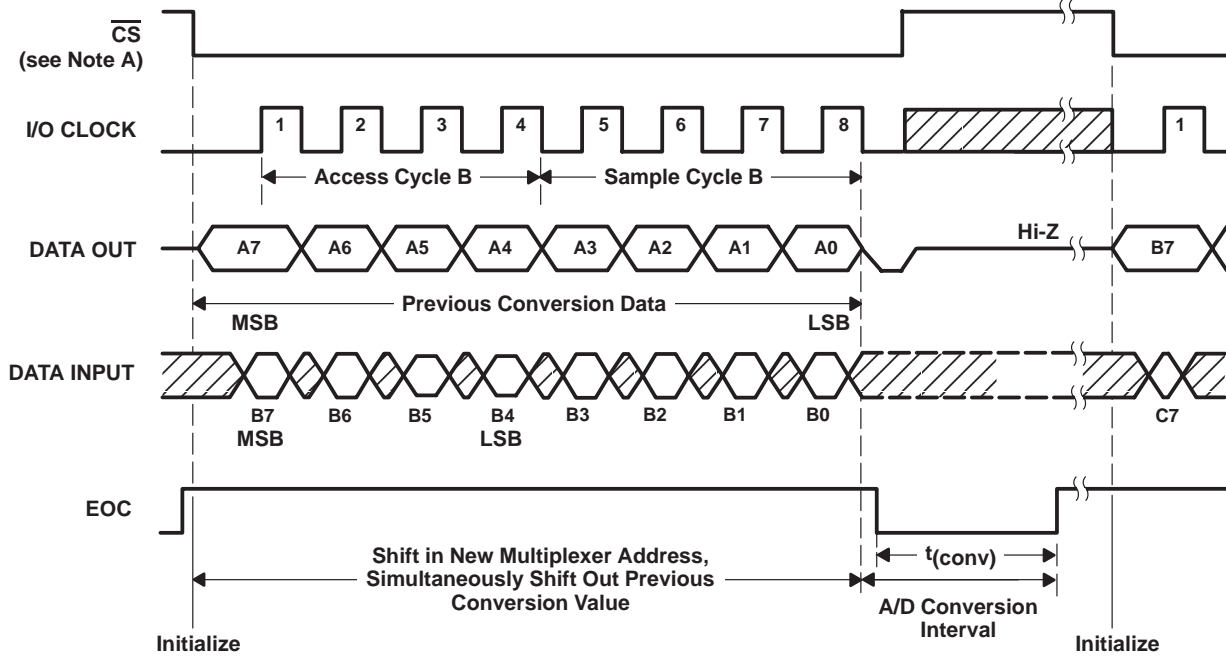

Figure 12. Timing for 8-Clock Transfer Using \overline{CS} With MSB First

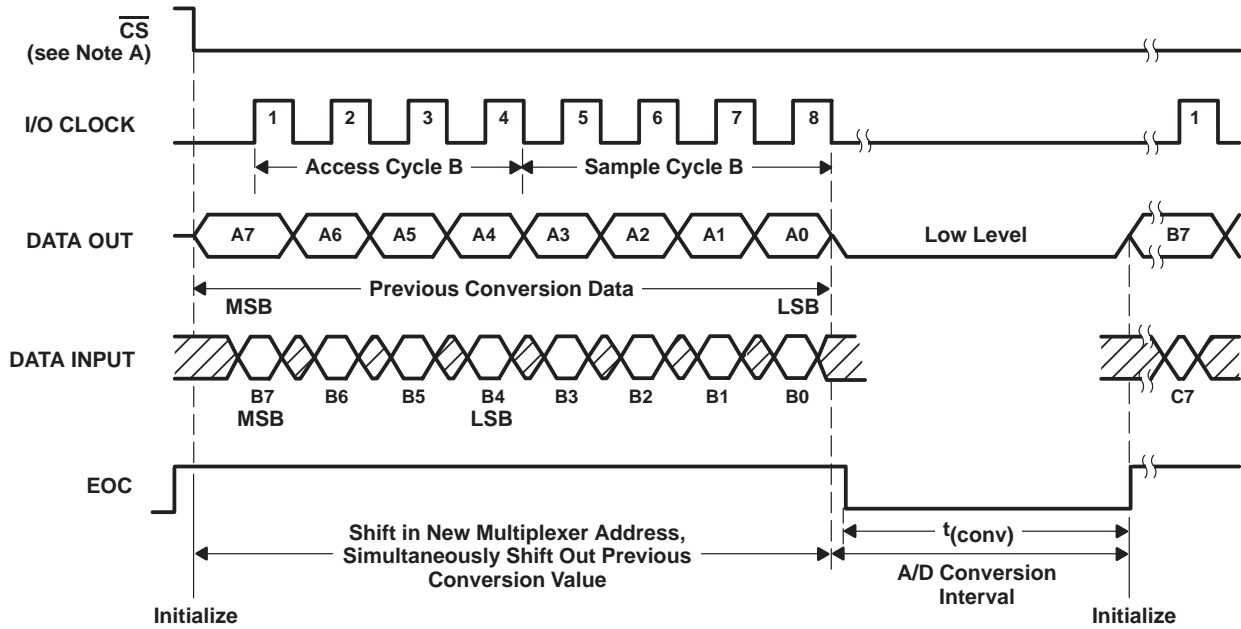

Figure 13. Timing for 8-Clock Transfer Not Using \overline{CS} With MSB First

NOTE A: To minimize errors caused by noise at \overline{CS} , the internal circuitry waits for a setup time after $\overline{CS}\downarrow$ before responding to control input signals. Therefore, no attempt should be made to clock in an address until the minimum \overline{CS} setup time has elapsed.

TLV2543C, TLV2543I
12-BIT ANALOG-TO-DIGITAL CONVERTERS
WITH SERIAL CONTROL AND 11 ANALOG INPUTS

SLAS096C – MARCH 1995 – REVISED JUNE 2000

PARAMETER MEASUREMENT INFORMATION

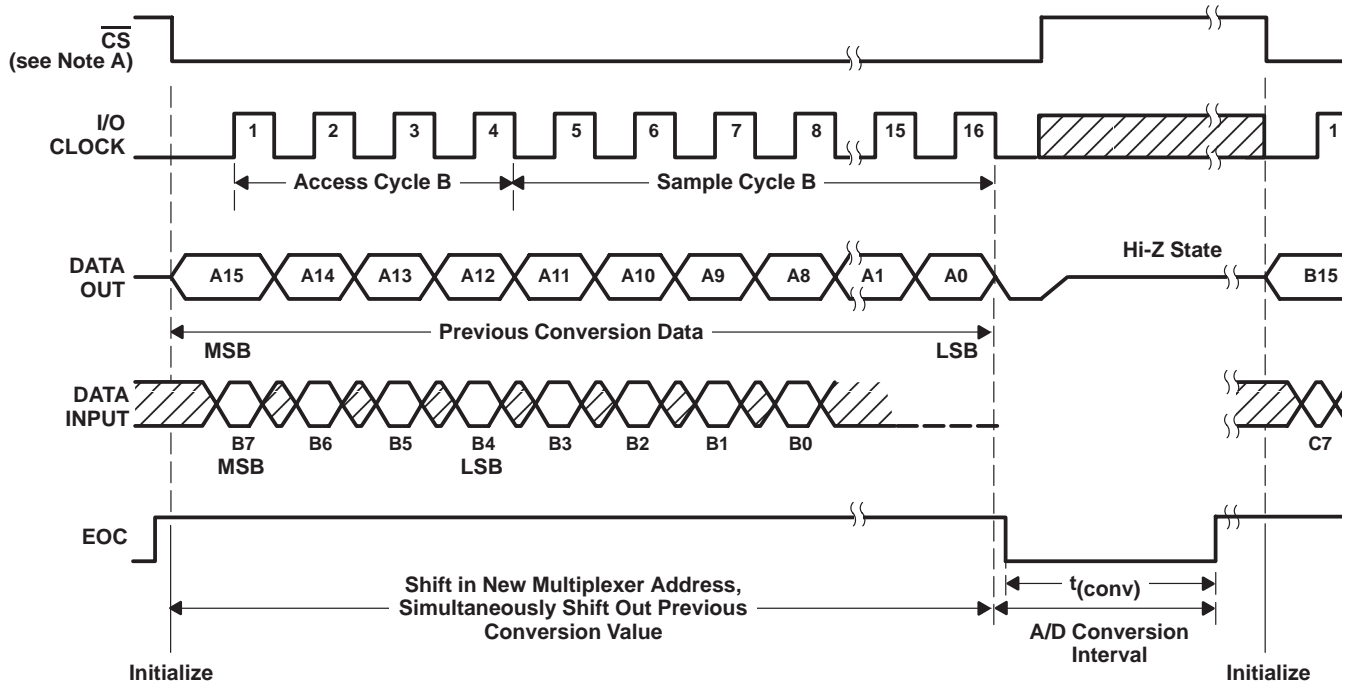

Figure 14. Timing for 16-Clock Transfer Using \overline{CS} With MSB First

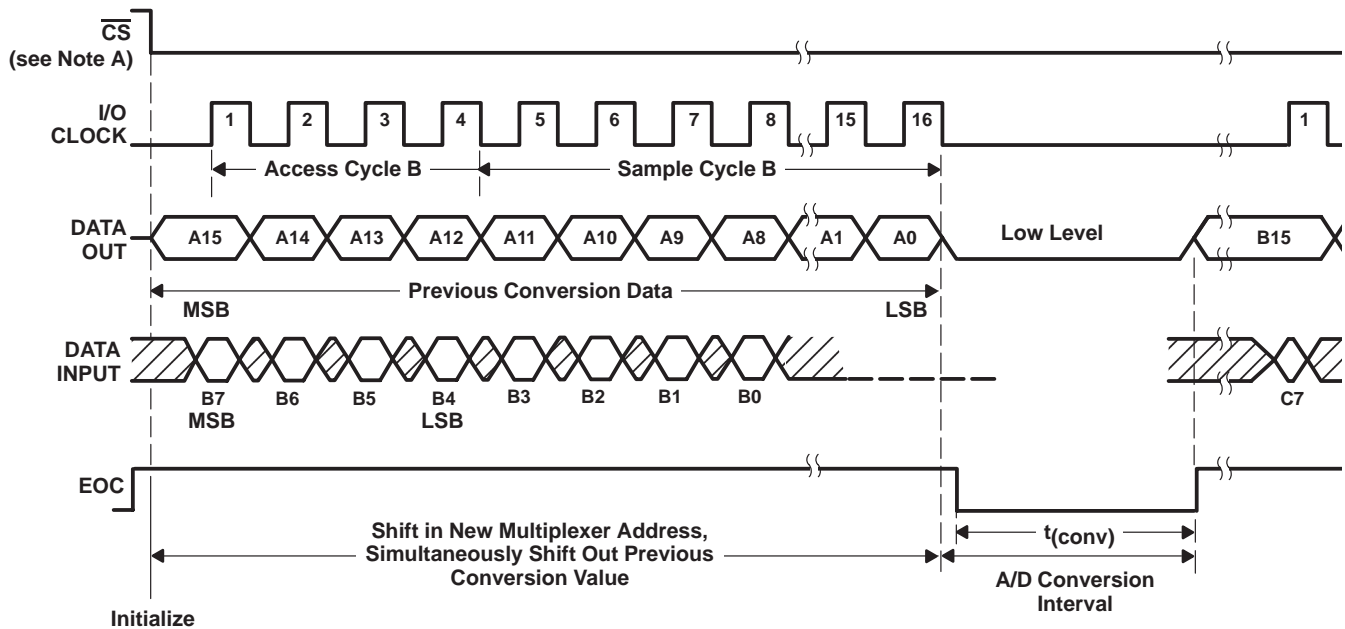
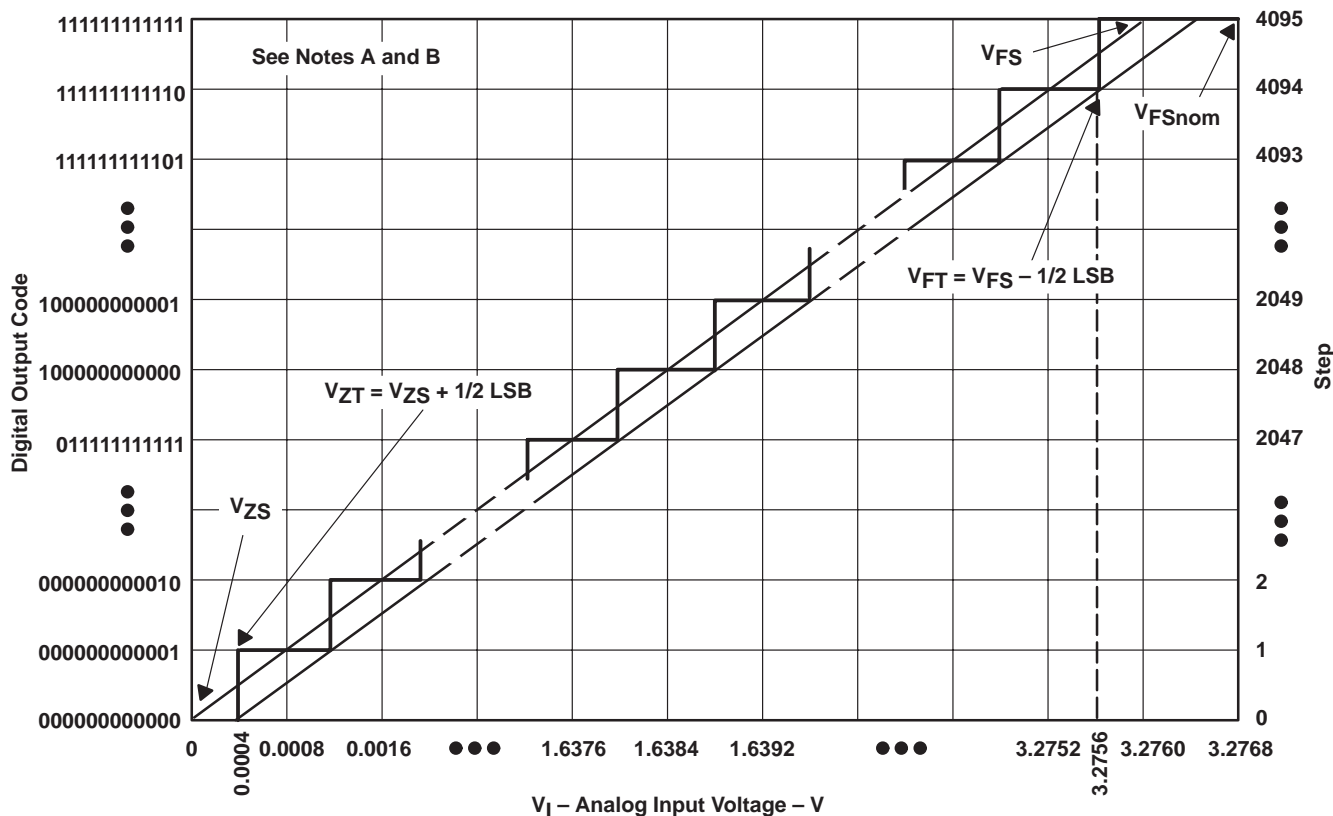

Figure 15. Timing for 16-Clock Transfer Not Using \overline{CS} With MSB First

NOTE A: To minimize errors caused by noise at \overline{CS} , the internal circuitry waits for a setup time after \overline{CS} before responding to control input signals. Therefore, no attempt should be made to clock in an address until the minimum \overline{CS} setup time has elapsed.

APPLICATION INFORMATION



- NOTES: A. This curve is based on the assumption that V_{ref+} and V_{ref-} have been adjusted so that the voltage at the transition from digital 0 to 1 (V_{ZT}) is 0.0004 V and the transition to full scale (V_{FT}) is 3.2756 V. 1 LSB = 0.8 mV.
- B. The full-scale value (V_{FS}) is the step whose nominal midstep value has the highest absolute value. The zero-scale value (V_{ZS}) is the step whose nominal midstep value equals zero.

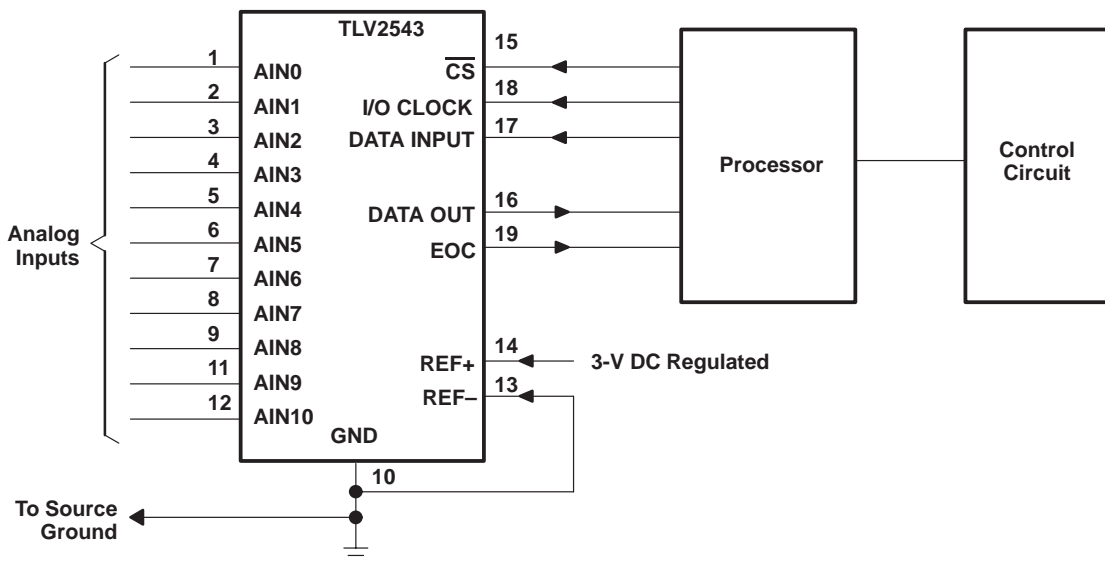

APPLICATIONS INFORMATION

simplified analog input analysis

Using the equivalent circuit in Figure 18, the time required to charge the analog input capacitance from 0 to V_S within 1/2 LSB can be derived as follows:

The capacitance charging voltage is given by

$$V_C = V_S \left(1 - e^{-t_c / R_t C_i} \right) \tag{1}$$

Where:

$$R_t = R_s + r_i$$

The final voltage to 1/2 LSB is given by

$$V_C (1/2 \text{ LSB}) = V_S - (V_S / 8192) \tag{2}$$

Equating equation 1 to equation 2 and solving for time t_c gives

$$V_S - (V_S / 8192) = V_S \left(1 - e^{-t_c / R_t C_i} \right) \tag{3}$$

and

$$t_c (1/2 \text{ LSB}) = R_t \times C_i \times \ln(8192) \tag{4}$$

Therefore, with the values given the time for the analog input signal to settle is

$$t_c (1/2 \text{ LSB}) = (R_s + 1 \text{ k}\Omega) \times 60 \text{ pF} \times \ln(8192) \tag{5}$$

This time must be less than the converter sample time shown in the timing diagrams.

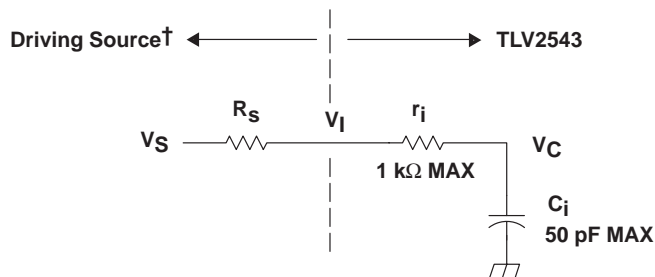

V_I = Input Voltage at AIN
 V_S = External Driving Source Voltage
 R_S = Source Resistance
 r_i = Input Resistance
 C_i = Input Capacitance

† Driving source requirements:

- Noise and distortion for the source must be equivalent to the resolution of the converter.
- R_S must be real at the input frequency.

Figure 18. Equivalent Input Circuit Including the Driving Source

TLV2543C, TLV2543I
**12-BIT ANALOG-TO-DIGITAL CONVERTERS
 WITH SERIAL CONTROL AND 11 ANALOG INPUTS**

SLAS096C – MARCH 1995 – REVISED JUNE 2000

MECHANICAL DATA

DB (R-PDSO-G)**

PLASTIC SMALL-OUTLINE PACKAGE

28 PIN SHOWN

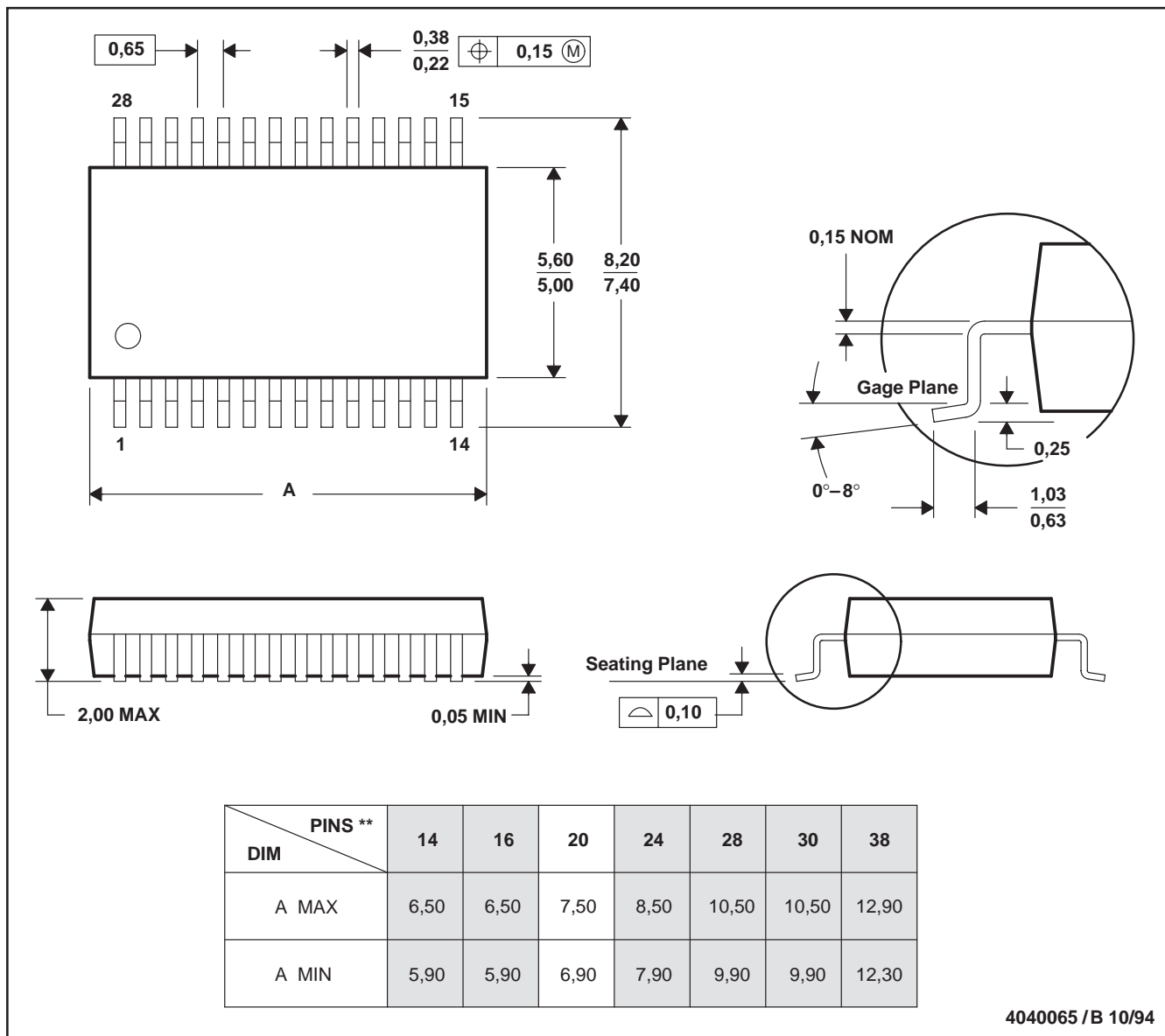

- NOTES: A. All linear dimensions are in millimeters.
 B. This drawing is subject to change without notice.
 C. Body dimensions do not include mold flash or protrusion not to exceed 0,15.
 D. Falls within JEDEC MO-150

TLV2543C, TLV2543I
12-BIT ANALOG-TO-DIGITAL CONVERTERS
WITH SERIAL CONTROL AND 11 ANALOG INPUTS

SLAS096C – MARCH 1995 – REVISED JUNE 2000

MECHANICAL DATA

DW (R-PDSO-G)**

PLASTIC SMALL-OUTLINE PACKAGE

16 PIN SHOWN

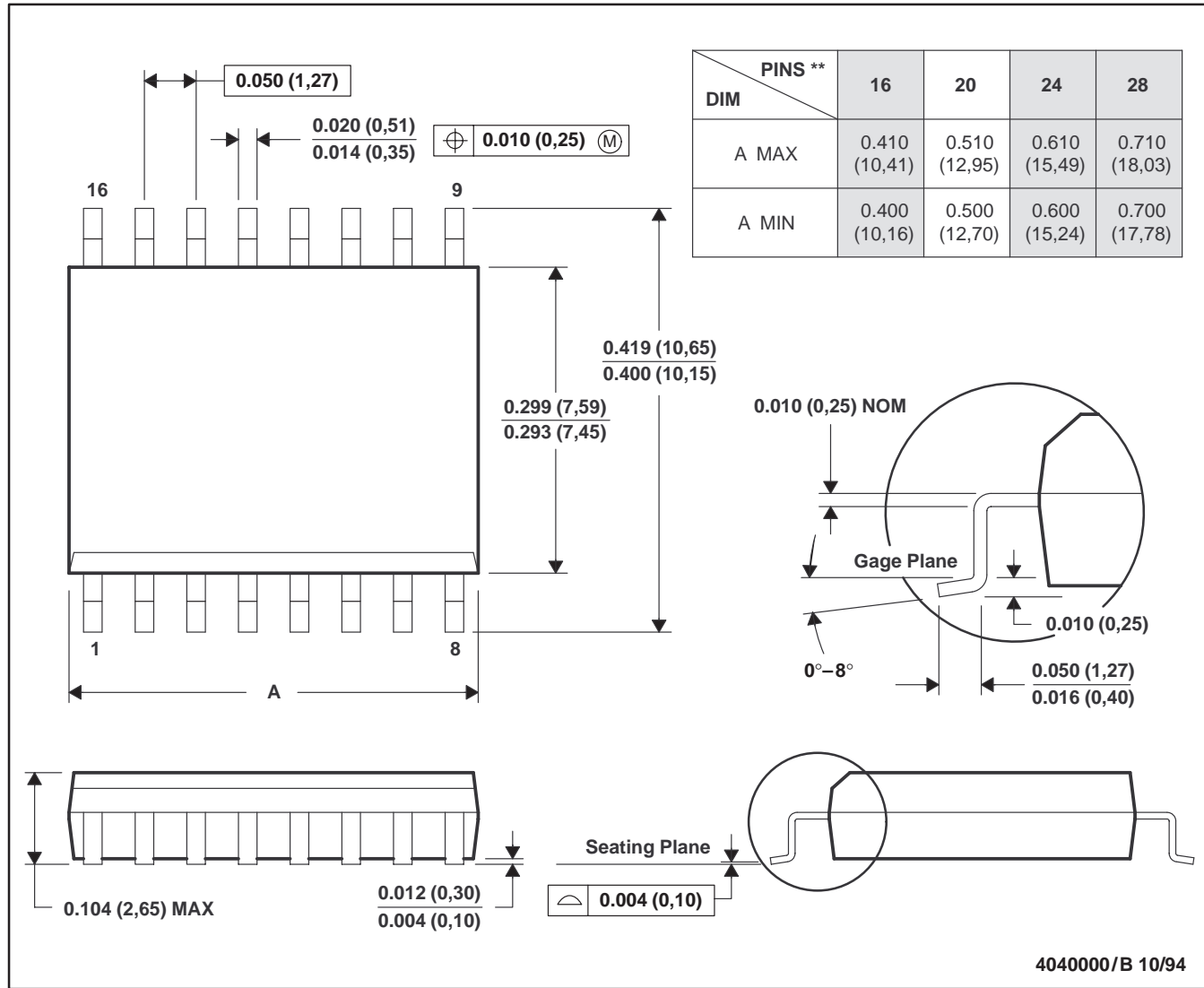

- NOTES: A. All linear dimensions are in inches (millimeters).
 B. This drawing is subject to change without notice.
 C. Body dimensions do not include mold flash or protrusion not to exceed 0.006 (0,15).
 D. Falls within JEDEC MS-013

TLV2543C, TLV2543I
12-BIT ANALOG-TO-DIGITAL CONVERTERS
WITH SERIAL CONTROL AND 11 ANALOG INPUTS

SLAS096C – MARCH 1995 – REVISED JUNE 2000

MECHANICAL DATA

N (R-PDIP-T)**

PLASTIC DUAL-IN-LINE PACKAGE

16 PIN SHOWN

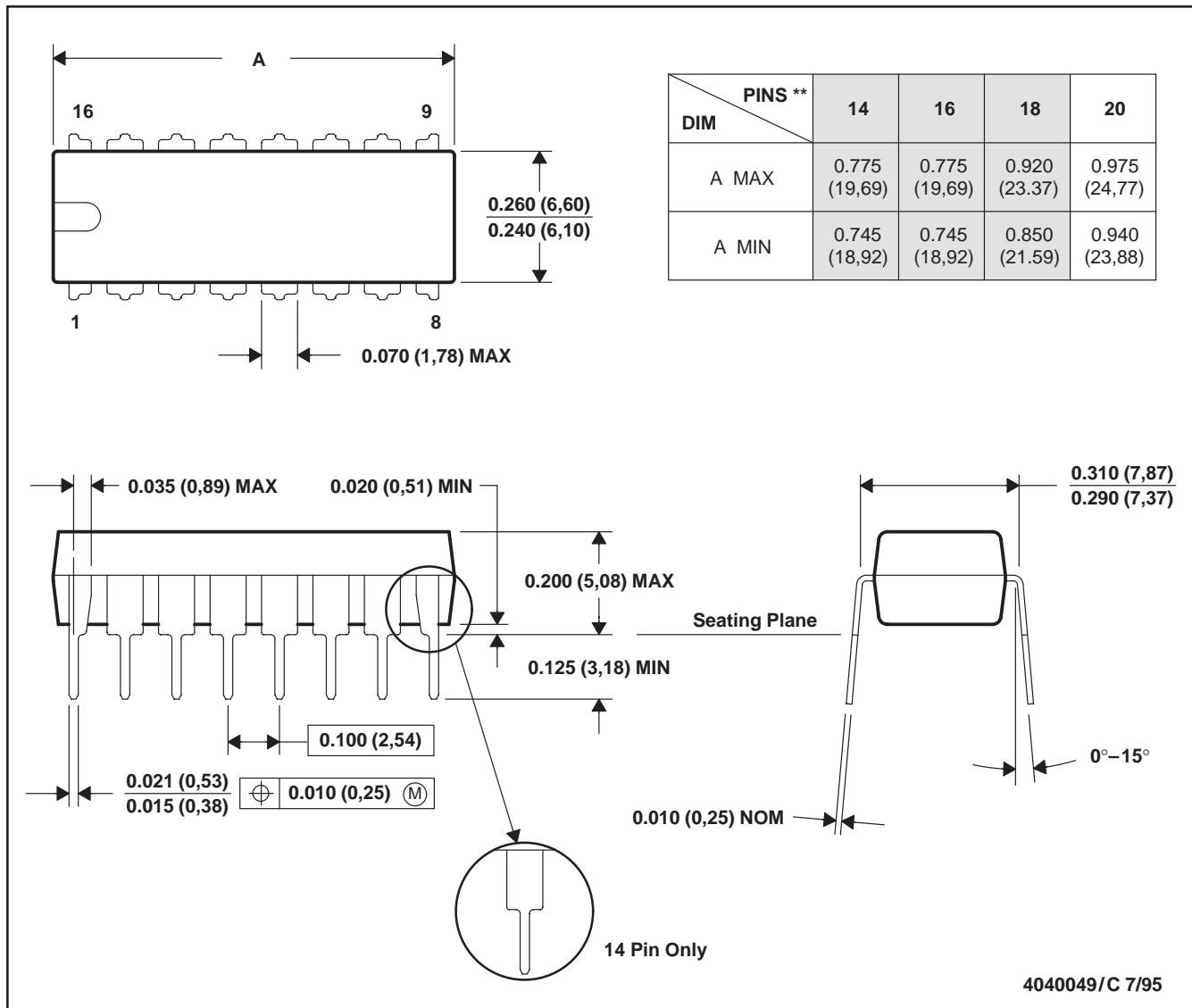

- NOTES: A. All linear dimensions are in inches (millimeters).
 B. This drawing is subject to change without notice.
 C. Falls within JEDEC MS-001 (20-pin package is shorter than MS-001)

PACKAGING INFORMATION

Orderable Device	Status ⁽¹⁾	Package Type	Package Drawing	Pins	Package Qty	Eco Plan ⁽²⁾	Lead/Ball Finish	MSL Peak Temp ⁽³⁾
TLV2543CDB	ACTIVE	SSOP	DB	20	70	Green (RoHS & no Sb/Br)	CU NIPDAU	Level-1-260C-UNLIM
TLV2543CDBG4	ACTIVE	SSOP	DB	20	70	Green (RoHS & no Sb/Br)	CU NIPDAU	Level-1-260C-UNLIM
TLV2543CDBR	ACTIVE	SSOP	DB	20	2000	Green (RoHS & no Sb/Br)	CU NIPDAU	Level-1-260C-UNLIM
TLV2543CDBRG4	ACTIVE	SSOP	DB	20	2000	Green (RoHS & no Sb/Br)	CU NIPDAU	Level-1-260C-UNLIM
TLV2543CDW	ACTIVE	SOIC	DW	20	25	Green (RoHS & no Sb/Br)	CU NIPDAU	Level-1-260C-UNLIM
TLV2543CDWG4	ACTIVE	SOIC	DW	20	25	Green (RoHS & no Sb/Br)	CU NIPDAU	Level-1-260C-UNLIM
TLV2543CDWR	ACTIVE	SOIC	DW	20	2000	Green (RoHS & no Sb/Br)	CU NIPDAU	Level-1-260C-UNLIM
TLV2543CDWRG4	ACTIVE	SOIC	DW	20	2000	Green (RoHS & no Sb/Br)	CU NIPDAU	Level-1-260C-UNLIM
TLV2543CN	ACTIVE	PDIP	N	20	20	Pb-Free (RoHS)	CU NIPDAU	N / A for Pkg Type
TLV2543CNE4	ACTIVE	PDIP	N	20	20	Pb-Free (RoHS)	CU NIPDAU	N / A for Pkg Type
TLV2543IDB	ACTIVE	SSOP	DB	20	70	Green (RoHS & no Sb/Br)	CU NIPDAU	Level-1-260C-UNLIM
TLV2543IDBG4	ACTIVE	SSOP	DB	20	70	Green (RoHS & no Sb/Br)	CU NIPDAU	Level-1-260C-UNLIM
TLV2543IDBR	ACTIVE	SSOP	DB	20	2000	Green (RoHS & no Sb/Br)	CU NIPDAU	Level-1-260C-UNLIM
TLV2543IDBRG4	ACTIVE	SSOP	DB	20	2000	Green (RoHS & no Sb/Br)	CU NIPDAU	Level-1-260C-UNLIM
TLV2543IDW	ACTIVE	SOIC	DW	20	25	Green (RoHS & no Sb/Br)	CU NIPDAU	Level-1-260C-UNLIM
TLV2543IDWG4	ACTIVE	SOIC	DW	20	25	Green (RoHS & no Sb/Br)	CU NIPDAU	Level-1-260C-UNLIM
TLV2543IDWR	ACTIVE	SOIC	DW	20	2000	Green (RoHS & no Sb/Br)	CU NIPDAU	Level-1-260C-UNLIM
TLV2543IDWRG4	ACTIVE	SOIC	DW	20	2000	Green (RoHS & no Sb/Br)	CU NIPDAU	Level-1-260C-UNLIM
TLV2543IN	ACTIVE	PDIP	N	20	20	Pb-Free (RoHS)	CU NIPDAU	N / A for Pkg Type
TLV2543INE4	ACTIVE	PDIP	N	20	20	Pb-Free (RoHS)	CU NIPDAU	N / A for Pkg Type

⁽¹⁾ The marketing status values are defined as follows:

ACTIVE: Product device recommended for new designs.

LIFEBUY: TI has announced that the device will be discontinued, and a lifetime-buy period is in effect.

NRND: Not recommended for new designs. Device is in production to support existing customers, but TI does not recommend using this part in a new design.

PREVIEW: Device has been announced but is not in production. Samples may or may not be available.

OBsolete: TI has discontinued the production of the device.

⁽²⁾ Eco Plan - The planned eco-friendly classification: Pb-Free (RoHS), Pb-Free (RoHS Exempt), or Green (RoHS & no Sb/Br) - please check <http://www.ti.com/productcontent> for the latest availability information and additional product content details.

TBD: The Pb-Free/Green conversion plan has not been defined.

Pb-Free (RoHS): TI's terms "Lead-Free" or "Pb-Free" mean semiconductor products that are compatible with the current RoHS requirements for all 6 substances, including the requirement that lead not exceed 0.1% by weight in homogeneous materials. Where designed to be soldered at high temperatures, TI Pb-Free products are suitable for use in specified lead-free processes.

Pb-Free (RoHS Exempt): This component has a RoHS exemption for either 1) lead-based flip-chip solder bumps used between the die and package, or 2) lead-based die adhesive used between the die and leadframe. The component is otherwise considered Pb-Free (RoHS compatible) as defined above.

Green (RoHS & no Sb/Br): TI defines "Green" to mean Pb-Free (RoHS compatible), and free of Bromine (Br) and Antimony (Sb) based flame retardants (Br or Sb do not exceed 0.1% by weight in homogeneous material)

⁽³⁾ MSL, Peak Temp. -- The Moisture Sensitivity Level rating according to the JEDEC industry standard classifications, and peak solder temperature.

Important Information and Disclaimer:The information provided on this page represents TI's knowledge and belief as of the date that it is provided. TI bases its knowledge and belief on information provided by third parties, and makes no representation or warranty as to the accuracy of such information. Efforts are underway to better integrate information from third parties. TI has taken and continues to take reasonable steps to provide representative and accurate information but may not have conducted destructive testing or chemical analysis on incoming materials and chemicals. TI and TI suppliers consider certain information to be proprietary, and thus CAS numbers and other limited information may not be available for release.

In no event shall TI's liability arising out of such information exceed the total purchase price of the TI part(s) at issue in this document sold by TI to Customer on an annual basis.

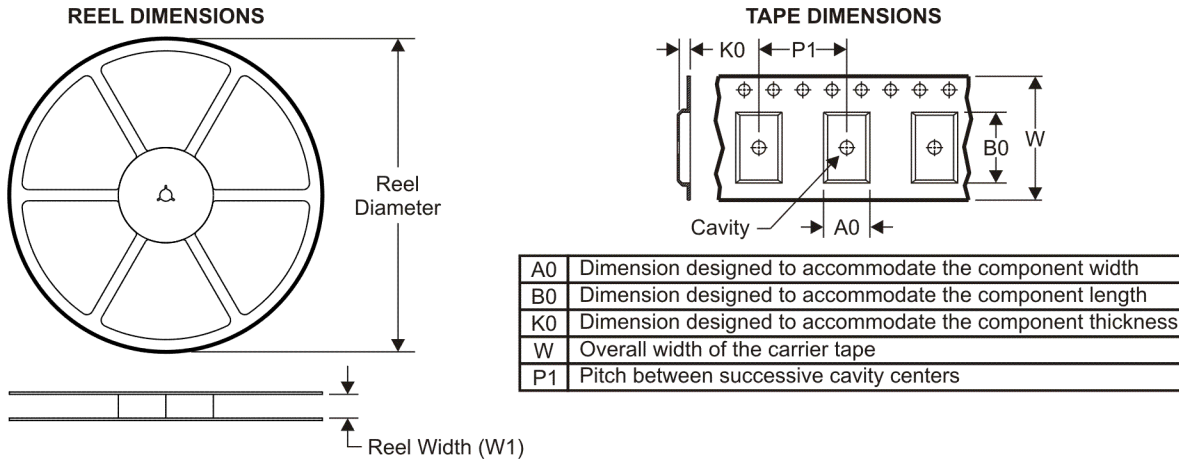
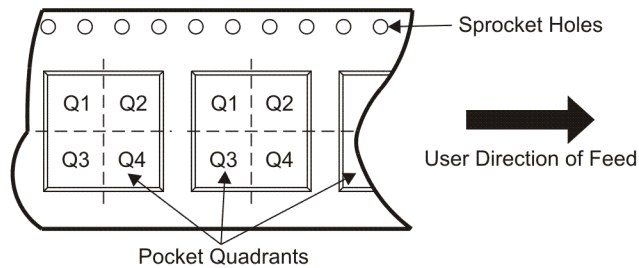
TAPE AND REEL INFORMATION

QUADRANT ASSIGNMENTS FOR PIN 1 ORIENTATION IN TAPE

*All dimensions are nominal

Device	Package Type	Package Drawing	Pins	SPQ	Reel Diameter (mm)	Reel Width W1 (mm)	A0 (mm)	B0 (mm)	K0 (mm)	P1 (mm)	W (mm)	Pin1 Quadrant
TLV2543CDBR	SSOP	DB	20	2000	330.0	16.4	8.2	7.5	2.5	12.0	16.0	Q1
TLV2543IDBR	SSOP	DB	20	2000	330.0	16.4	8.2	7.5	2.5	12.0	16.0	Q1

TAPE AND REEL BOX DIMENSIONS



*All dimensions are nominal

Device	Package Type	Package Drawing	Pins	SPQ	Length (mm)	Width (mm)	Height (mm)
TLV2543CDBR	SSOP	DB	20	2000	346.0	346.0	33.0
TLV2543IDBR	SSOP	DB	20	2000	346.0	346.0	33.0

IMPORTANT NOTICE

Texas Instruments Incorporated and its subsidiaries (TI) reserve the right to make corrections, modifications, enhancements, improvements, and other changes to its products and services at any time and to discontinue any product or service without notice. Customers should obtain the latest relevant information before placing orders and should verify that such information is current and complete. All products are sold subject to TI's terms and conditions of sale supplied at the time of order acknowledgment.

TI warrants performance of its hardware products to the specifications applicable at the time of sale in accordance with TI's standard warranty. Testing and other quality control techniques are used to the extent TI deems necessary to support this warranty. Except where mandated by government requirements, testing of all parameters of each product is not necessarily performed.

TI assumes no liability for applications assistance or customer product design. Customers are responsible for their products and applications using TI components. To minimize the risks associated with customer products and applications, customers should provide adequate design and operating safeguards.

TI does not warrant or represent that any license, either express or implied, is granted under any TI patent right, copyright, mask work right, or other TI intellectual property right relating to any combination, machine, or process in which TI products or services are used. Information published by TI regarding third-party products or services does not constitute a license from TI to use such products or services or a warranty or endorsement thereof. Use of such information may require a license from a third party under the patents or other intellectual property of the third party, or a license from TI under the patents or other intellectual property of TI.

Reproduction of TI information in TI data books or data sheets is permissible only if reproduction is without alteration and is accompanied by all associated warranties, conditions, limitations, and notices. Reproduction of this information with alteration is an unfair and deceptive business practice. TI is not responsible or liable for such altered documentation. Information of third parties may be subject to additional restrictions.

Resale of TI products or services with statements different from or beyond the parameters stated by TI for that product or service voids all express and any implied warranties for the associated TI product or service and is an unfair and deceptive business practice. TI is not responsible or liable for any such statements.

TI products are not authorized for use in safety-critical applications (such as life support) where a failure of the TI product would reasonably be expected to cause severe personal injury or death, unless officers of the parties have executed an agreement specifically governing such use. Buyers represent that they have all necessary expertise in the safety and regulatory ramifications of their applications, and acknowledge and agree that they are solely responsible for all legal, regulatory and safety-related requirements concerning their products and any use of TI products in such safety-critical applications, notwithstanding any applications-related information or support that may be provided by TI. Further, Buyers must fully indemnify TI and its representatives against any damages arising out of the use of TI products in such safety-critical applications.

TI products are neither designed nor intended for use in military/aerospace applications or environments unless the TI products are specifically designated by TI as military-grade or "enhanced plastic." Only products designated by TI as military-grade meet military specifications. Buyers acknowledge and agree that any such use of TI products which TI has not designated as military-grade is solely at the Buyer's risk, and that they are solely responsible for compliance with all legal and regulatory requirements in connection with such use.

TI products are neither designed nor intended for use in automotive applications or environments unless the specific TI products are designated by TI as compliant with ISO/TS 16949 requirements. Buyers acknowledge and agree that, if they use any non-designated products in automotive applications, TI will not be responsible for any failure to meet such requirements.

Following are URLs where you can obtain information on other Texas Instruments products and application solutions:

Products

Amplifiers	amplifier.ti.com
Data Converters	dataconverter.ti.com
DLP® Products	www.dlp.com
DSP	dsp.ti.com
Clocks and Timers	www.ti.com/clocks
Interface	interface.ti.com
Logic	logic.ti.com
Power Mgmt	power.ti.com
Microcontrollers	microcontroller.ti.com
RFID	www.ti-rfid.com
RF/IF and ZigBee® Solutions	www.ti.com/lprf

Applications

Audio	www.ti.com/audio
Automotive	www.ti.com/automotive
Broadband	www.ti.com/broadband
Digital Control	www.ti.com/digitalcontrol
Medical	www.ti.com/medical
Military	www.ti.com/military
Optical Networking	www.ti.com/opticalnetwork
Security	www.ti.com/security
Telephony	www.ti.com/telephony
Video & Imaging	www.ti.com/video
Wireless	www.ti.com/wireless

Mailing Address: Texas Instruments, Post Office Box 655303, Dallas, Texas 75265
Copyright © 2009, Texas Instruments Incorporated

Looking for pricing, stock, or lifecycle information?

Click below to explore more details on WIN SOURCE:

 [View TLV2543CDBRG4 on WIN SOURCE](#)

 [Texas Instruments](#) Information

Optimize Your Supply Chain with WIN SOURCE Solutions

-  Global Sourcing Solution
-  Obsolete Management
-  Cost Control Management
-  Shortage Management
-  Alternative Solution
-  Excess Inventory Management