



**THE DATASHEET OF
NLSV4T3144MUTAG**



NLSV4T3144

4-Bit Dual-Supply Non-Inverting Level Translator

The NLSV4T3144 is a 4-bit configurable dual-supply bus buffer level translator. The input (IN_{xn}) and output (OUT_{xn}) ports are designed to track two different power supply rails, V_{CCA} and V_{CCB} respectively. Both supply rails are configurable from 1.6 V to 3.6 V allowing low-voltage translation from the input to the output port.

Features

- Wide V_{CCA} and V_{CCB} Operating Range: 1.6 V to 3.6 V
- High-Speed w/ Balanced Propagation Delay
- Inputs and Outputs have OVT Protection to 5.5 V
- Outputs at 3-State until Active V_{CCA} and V_{CCB} are Reached
- Power-Off Protection
- Ultra-Small Packaging: 1.7 mm x 2.0 mm UQFN-12
- These Devices are Pb-Free, Halogen Free/BFR Free and are RoHS Compliant

Typical Applications

- Mobile Phones, PDAs, Other Portable Devices
- SPI™ Bus Voltage Translation

Important Information

- ESD Protection for All Pins:
HBM (Human Body Model) > 3000 V

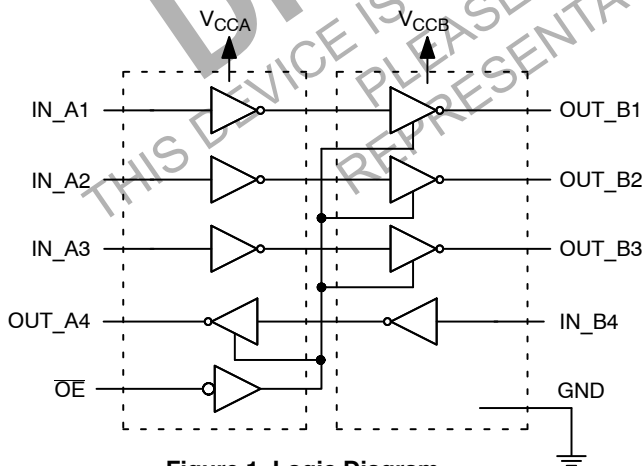
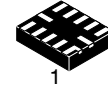

Figure 1. Logic Diagram



ON Semiconductor®

www.onsemi.com



UQFN12
MU SUFFIX
CASE 523AE

MARKING DIAGRAM



WG = Specific Device Code
M = Date Code
• = Pb-Free Package

(Note: Microdot may be in either location)

PIN ASSIGNMENTS

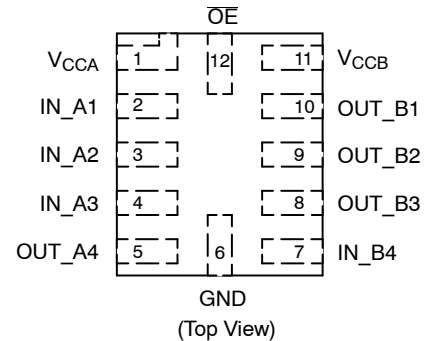

ORDERING INFORMATION

Device	Package	Shipping†
NLSV4T3144MUTAG	UQFN-12 (Pb-Free)	3000/Tape & Reel

†For information on tape and reel specifications, including part orientation and tape sizes, please refer to our Tape and Reel Packaging Specification Brochure, BRD8011/D.

NLSV4T3144

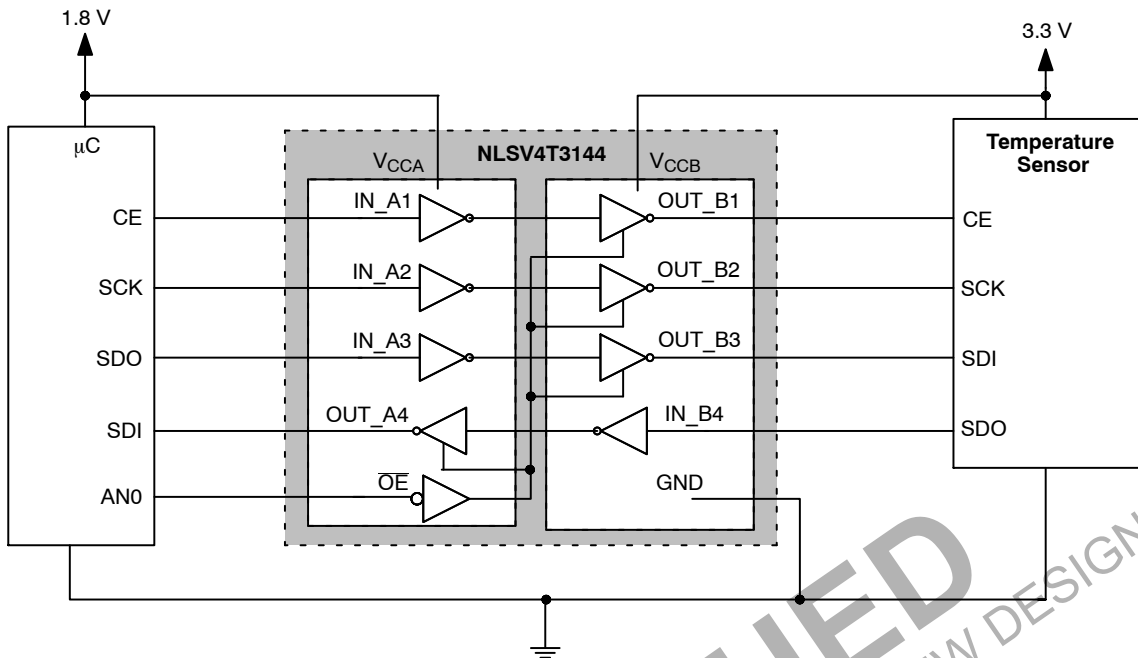

Figure 2. Typical Application: SPI Bus Voltage Translator

PIN NAMES

Pins	Description
V _{CCA}	'A' DC Power Supply
V _{CCB}	'B' DC Power Supply
GND	Ground
IN_A1, IN_A2, IN_A3	Input (Referenced to V _{CCA})
IN_B4	Input (Referenced to V _{CCB})
OUT_B1, OUT_B2, OUT_B3	Output (Referenced to V _{CCB})
OUT_A4	Output (Referenced to V _{CCA})
OE	Output Enable (Referenced to V _{CCA})

TRUTH TABLE

Inputs		Outputs
OE	IN_A1, IN_A2, IN_A3, IN_B4	OUT_B1, OUT_B2, OUT_B3, OUT_A4
H	X	3-State
L	L	L
	H	H

NLSV4T3144

MAXIMUM RATINGS

Symbol	Parameter	Value	Condition	Unit
V_{CCA}, V_{CCB}	DC Supply Voltage, $V_{CCA} \leq V_{CCB}$	-0.5 to +5.5		V
V_I	DC Input Voltage IN_{x_n}	-0.5 to +5.5		V
V_C	Control Input \overline{OE}	-0.5 to +5.5		V
V_O	DC Output Voltage (Power Down) OUT_{x_n}	-0.5 to +5.5	$V_{CCA} = V_{CCB} = 0$	V
	(Active Mode) OUT_{x_n}	-0.5 to +5.5		
	(Tri-State Mode) OUT_{x_n}	-0.5 to +5.5		
I_{IK}	DC Input Diode Current	-20	$V_I < GND$	mA
I_{OK}	DC Output Diode Current	-50	$V_O < GND$	mA
I_O	DC Output Source/Sink Current	± 50		mA
I_{CCA}, I_{CCB}	DC Supply Current Per Supply Pin	± 100		mA
I_{GND}	DC Ground Current per Ground Pin	± 100		mA
T_{STG}	Storage Temperature	-65 to +150		$^{\circ}C$

Stresses exceeding those listed in the Maximum Ratings table may damage the device. If any of these limits are exceeded, device functionality should not be assumed, damage may occur and reliability may be affected.

RECOMMENDED OPERATING CONDITIONS

Symbol	Parameter	Min	Max	Unit
V_{CCA}, V_{CCB}	Positive DC Supply Voltage, $V_{CCA} \leq V_{CCB}$	1.6	3.6	V
V_I	Bus Input Voltage	GND	3.6	V
V_C	Control Input \overline{OE}	GND	3.6	V
V_{IO}	DC Output Voltage (Power Down) OUT_{x_n}	GND	3.6	V
	(Active Mode) OUT_{x_n}			
	(Tri-State Mode) OUT_{x_n}			
T_A	Operating Temperature Range	-40	+85	$^{\circ}C$
$\Delta t / \Delta V$	Input Transition Rise or Rate V_I , from 30% to 70% of V_{CCA} and V_{CCB} ; $V_{CCA} = V_{CCB} = 3.3 V \pm 0.3 V$	0	10	ns

NLSV4T3144

DC ELECTRICAL CHARACTERISTICS

Symbol	Parameter	Test Conditions	V _{CCA} (V)	V _{CCB} (V)	-40°C to + 85°C		Unit
					Min	Max	
V _{IH} (IN_A1, IN_A2, IN_A3, OE)	Input HIGH Voltage		2.7 – 3.6	≥ V _{CCA}	2.0	-	V
			2.3 – 2.7		1.6	-	
			1.6 – 2.3		0.65 * V _{CCA}	-	
V _{IH} (IN_B4)	Input HIGH Voltage		≤ V _{CCB}	2.7 – 3.6	2.0	-	V
			2.3 – 2.7	1.6	-		
			1.6 – 2.3	0.65 * V _{CCB}	-		
V _{IL} (IN_A1, IN_A2, IN_A3, OE)	Input LOW Voltage		2.7 – 3.6	≥ V _{CCA}	-	0.8	V
			2.3 – 2.7		-	0.7	
			1.6 – 2.3		-	0.35 * V _{CCA}	
V _{IL} (IN_B4)	Input LOW Voltage		≤ V _{CCB}	2.7 – 3.6	-	0.8	V
			2.3 – 2.7	-	0.7		
			1.6 – 2.3	-	0.35 * V _{CCB}		
V _{OH} (OUT_B1, OUT_B2, OUT_B3)	Output HIGH Voltage	I _{OH} = -100 μA; V _I = V _{IH}	≤ V _{CCB}	1.6 – 3.6	V _{CCB} - 0.2	-	V
		I _{OH} = -6 mA; V _I = V _{IH}	1.6	1.6	1.25	-	
		I _{OH} = -12 mA; V _I = V _{IH}	2.3	2.3	2.0	-	
			2.7	2.7	2.2	-	
		I _{OH} = -18 mA; V _I = V _{IH}	2.3	2.3	1.7	-	
			3.0	3.0	2.4	-	
V _{OH} (OUT_A4)	Output HIGH Voltage	I _{OH} = -100 μA; V _I = V _{IH}	1.6 – 3.6	≥ V _{CCA}	V _{CCA} - 0.2	-	V
		I _{OH} = -6 mA; V _I = V _{IH}	1.6	1.6	1.25	-	
		I _{OH} = -12 mA; V _I = V _{IH}	2.3	2.3	2.0	-	
			2.7	2.7	2.2	-	
		I _{OH} = -18 mA; V _I = V _{IH}	2.3	2.3	1.7	-	
			3.0	3.0	2.4	-	
V _{OL} (OUT_B1, OUT_B2, OUT_B3)	Output LOW Voltage	I _{OL} = 100 μA; V _I = V _{IH}	≤ V _{CCB}	1.6 – 3.6	-	0.2	V
		I _{OL} = 6 mA; V _I = V _{IH}	1.6	1.6	-	0.3	
		I _{OL} = 12 mA; V _I = V _{IH}	2.3	2.3	-	0.4	
			2.7	2.7	-	0.4	
		I _{OL} = 18 mA; V _I = V _{IH}	2.3	2.3	-	0.6	
			3.0	3.0	-	0.5	
V _{OL} (OUT_A4)	Output LOW Voltage	I _{OL} = 100 μA; V _I = V _{IH}	1.6 – 3.6	≥ V _{CCA}	-	0.2	V
		I _{OL} = 6 mA; V _I = V _{IH}	1.6	1.6	-	0.3	
		I _{OL} = 12 mA; V _I = V _{IH}	2.3	2.3	-	0.4	
			2.7	2.7	-	0.4	
		I _{OL} = 18 mA; V _I = V _{IH}	2.3	2.3	-	0.6	
			3.0	3.0	-	0.5	
I _{OL} = 24 mA; V _I = V _{IH}	3.0	3.0	-	0.6			

NLSV4T3144

DC ELECTRICAL CHARACTERISTICS

Symbol	Parameter	Test Conditions	V _{CCA} (V)	V _{CCB} (V)	-40°C to +85°C		Unit
					Min	Max	
I _{IN}	Input Leakage Current	V _{IN_A1} = V _{IN_A2} = V _{IN_A3} = V _{CCA} or GND; V _{IN_B4} = V _{CCB} or GND	≤ V _{CCB}	1.6 – 3.6	-1.0	+1.0	μA
I _{OZ}	I/O Tri – State Output Leakage Current	T _A = 25°C, \overline{OE} = V _{CCA}	≤ V _{CCB}	1.6 – 3.6	–	1.0	μA
I _{CCA}	Quiescent Supply Current	V _{IN_A1} = V _{IN_A2} = V _{IN_A3} = V _{CCA} or GND; V _{IN_B4} = V _{CCB} or GND \overline{OE} = GND, I _O = 0	≤ V _{CCB}	1.6 – 3.6	–	3.0	μA
I _{CCB}	Quiescent Supply Current	V _{IN_A1} = V _{IN_A2} = V _{IN_A3} = V _{CCA} or GND; V _{IN_B4} = V _{CCB} or GND \overline{OE} = GND, I _O = 0	≤ V _{CCB}	1.6 – 3.6	–	3.0	μA
I _{CCA} + I _{CCB}	Quiescent Supply Current	V _{IN_A1} = V _{IN_A2} = V _{IN_A3} = V _{CCA} or GND; V _{IN_B4} = V _{CCB} or GND \overline{OE} = GND, I _O = 0	≤ V _{CCB}	1.6 – 3.6	–	6.0	μA

NOTE: Connect ground before applying supply voltage V_{CCA} or V_{CCB}. This device is designed with the feature that the power-up sequence of V_{CCA} and V_{CCB} will not damage the IC.

AC ELECTRICAL CHARACTERISTICS

Symbol	Parameter	V _{CCA} (V)	-40°C to +85°C						Unit
			V _{CCB} (V)						
			3.6		2.8		1.6		
		Min	Max	Min	Max	Min	Max		
t _{PLH} , t _{PHL}	Propagation Delay, Input to Output	3.6		3					ns
		2.8		3.1		3.3			
		1.6		4.3		4.5		6.1	
t _{PZH} , t _{PZL}	Output Enable, OE to Output	3.6		8.7					ns
		2.8		10.3		10.7			
		1.6		17.2		18		20	
t _{PHZ} , t _{PLZ}	Output Disable, OE to Output	3.6		7.8					ns
		2.8		8.2		8.4			
		1.6		9.5		9.8		10.5	
t _{OSSL} , t _{OSLH}	Output to Output Skew	3.6		0.25					ns
		2.8		0.25		0.25			
		1.6		0.25		0.25		0.25	

NOTE: Propagation delays defined per Figure 3.

CAPACITANCE

Symbol	Parameter	Test Conditions	Typ (Note 1)	Unit
C _I	Control Pin (\overline{OE}) Input Capacitance	V _{CCA} = V _{CCB} = 3.3 V, V _I = 0 V or V _{CCA/B}	3.5	pF
C _{IN}	Input Pin Capacitance	V _{CCA} = V _{CCB} = 3.3 V, V _I = 0 V or V _{CCA/B}	5.0	pF
C _{OUT}	Output Pin Capacitance	V _{CCA} = V _{CCB} = 3.3 V, V _I = 0 V or V _{CCA/B}	5.0	pF
C _{PD}	Power Dissipation Capacitance	V _{CCA} = V _{CC2} = 3.3 V, V _I = 0 V or 3.3 V, f = 10 MHz	10	pF

1. Typical values are at T_A = +25°C.

NLSV4T3144

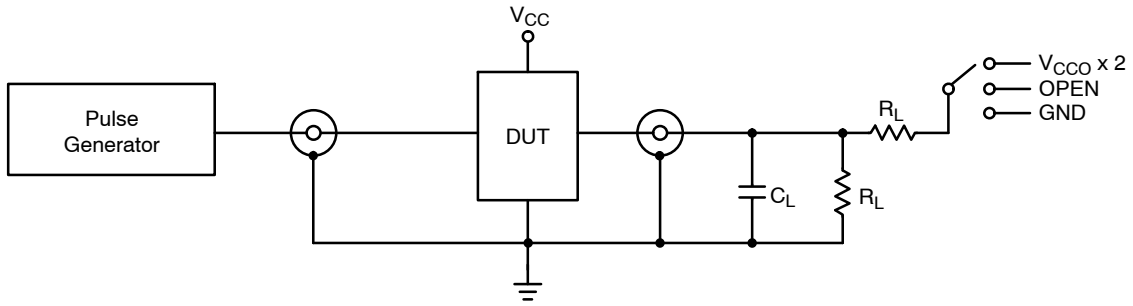
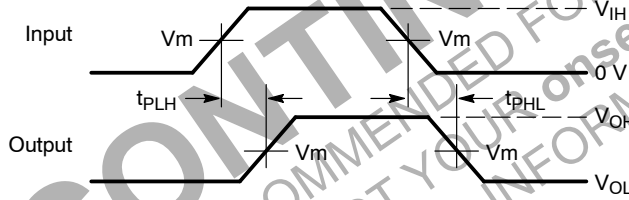

Figure 3. AC (Propagation Delay) Test Circuit

Test	Switch
t_{PLH} , t_{PHL}	OPEN
t_{PLZ} , t_{PZL}	$V_{CCO} \times 2$ at $V_{CCO} = 3.0\text{ V} - 3.6\text{ V}, 2.3\text{ V} - 2.7\text{ V}, 1.65\text{ V} - 1.95\text{ V}, 1.4\text{ V} - 1.6\text{ V}$
t_{PHZ} , t_{PZH}	GND

$C_L = 15\text{ pF}$ or equivalent (includes probe and jig capacitance)
 $R_L = 2\text{ k}\Omega$ or equivalent
 Z_{OUT} of pulse generator = $50\ \Omega$
 V_{CCO} is the supply voltage referenced to by the output being tested



Waveform 1 - Propagation Delays

$t_R = t_F = 2.0\text{ ns}$, 10% to 90%; $f = 1\text{ MHz}$; $t_W = 500\text{ ns}$

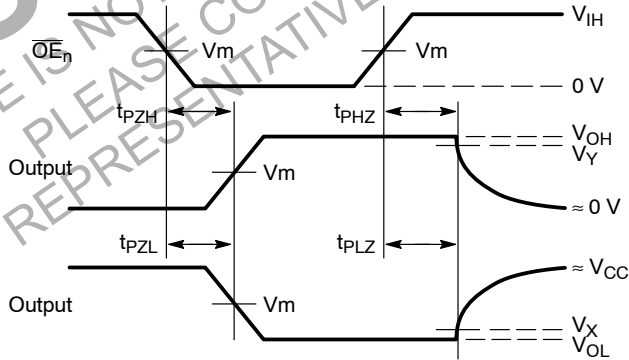

Waveform 2 - Output Enable and Disable Times

$t_R = t_F = 2.0\text{ ns}$, 10% to 90%; $f = 1\text{ MHz}$; $t_W = 500\text{ ns}$

Figure 4. AC (Propagation Delay) Test Circuit Waveforms

Symbol	Input Pin Output Pin
V_m	$V_{CCX}/2$
V_X	$V_{OL} \times 0.1$
V_Y	$V_{OH} \times 0.9$

MECHANICAL CASE OUTLINE PACKAGE DIMENSIONS

ON Semiconductor®



UQFN12 1.7x2.0, 0.4P CASE 523AE-01 ISSUE A

DATE 11 JUN 2007

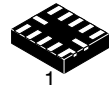

SCALE 4:1

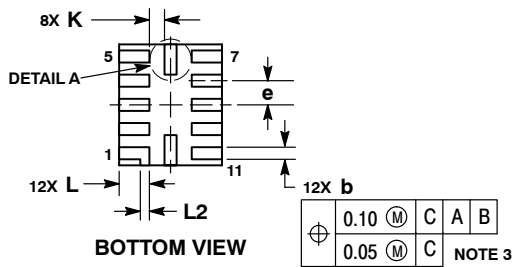
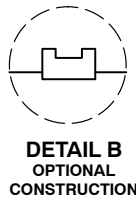
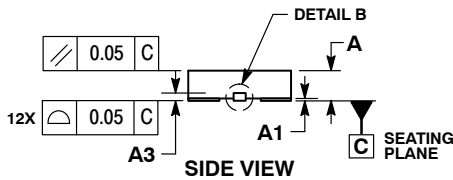
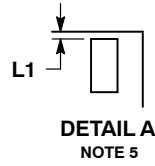
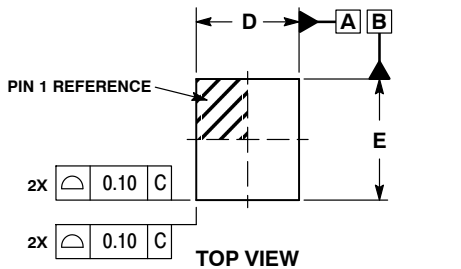

NOTES:

- DIMENSIONING AND TOLERANCING PER ASME Y14.5M, 1994.
- CONTROLLING DIMENSION: MILLIMETERS
- DIMENSION b APPLIES TO PLATED TERMINAL AND IS MEASURED BETWEEN 0.15 AND 0.30 MM FROM TERMINAL TIP.
- MOLD FLASH ALLOWED ON TERMINALS ALONG EDGE OF PACKAGE. FLASH 0.03 MAX ON BOTTOM SURFACE OF TERMINALS.
- DETAIL A SHOWS OPTIONAL CONSTRUCTION FOR TERMINALS.

DIM	MILLIMETERS	
	MIN	MAX
A	0.45	0.55
A1	0.00	0.05
A3	0.127 REF	
b	0.15	0.25
D	1.70 BSC	
E	2.00 BSC	
e	0.40 BSC	
K	0.20	---
L	0.45	0.55
L1	0.00	0.03
L2	0.15 REF	

GENERIC MARKING DIAGRAM*

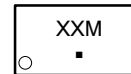

- XX = Specific Device Code
- M = Date Code
- = Pb-Free Package

*This information is generic. Please refer to device data sheet for actual part marking. Pb-Free indicator, "G" or microdot "▪", may or may not be present.

MOUNTING FOOTPRINT SOLDERMASK DEFINED

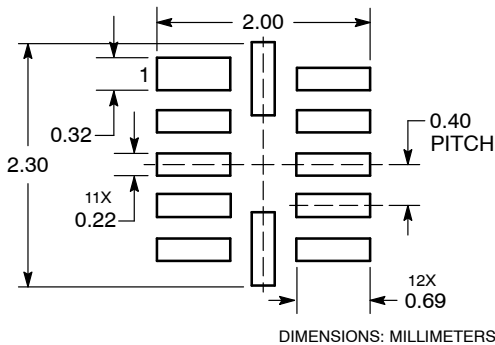

DOCUMENT NUMBER:	98AON23418D	Electronic versions are uncontrolled except when accessed directly from the Document Repository. Printed versions are uncontrolled except when stamped "CONTROLLED COPY" in red.
DESCRIPTION:	UQFN12 1.7 X 2.0, 0.4P	PAGE 1 OF 1

ON Semiconductor and ON are trademarks of Semiconductor Components Industries, LLC dba ON Semiconductor or its subsidiaries in the United States and/or other countries. ON Semiconductor reserves the right to make changes without further notice to any products herein. ON Semiconductor makes no warranty, representation or guarantee regarding the suitability of its products for any particular purpose, nor does ON Semiconductor assume any liability arising out of the application or use of any product or circuit, and specifically disclaims any and all liability, including without limitation special, consequential or incidental damages. ON Semiconductor does not convey any license under its patent rights nor the rights of others.

onsemi, **Onsemi**, and other names, marks, and brands are registered and/or common law trademarks of Semiconductor Components Industries, LLC dba "**onsemi**" or its affiliates and/or subsidiaries in the United States and/or other countries. **onsemi** owns the rights to a number of patents, trademarks, copyrights, trade secrets, and other intellectual property. A listing of **onsemi**'s product/patent coverage may be accessed at www.onsemi.com/site/pdf/Patent-Marking.pdf. **onsemi** reserves the right to make changes at any time to any products or information herein, without notice. The information herein is provided "as-is" and **onsemi** makes no warranty, representation or guarantee regarding the accuracy of the information, product features, availability, functionality, or suitability of its products for any particular purpose, nor does **onsemi** assume any liability arising out of the application or use of any product or circuit, and specifically disclaims any and all liability, including without limitation special, consequential or incidental damages. Buyer is responsible for its products and applications using **onsemi** products, including compliance with all laws, regulations and safety requirements or standards, regardless of any support or applications information provided by **onsemi**. "Typical" parameters which may be provided in **onsemi** data sheets and/or specifications can and do vary in different applications and actual performance may vary over time. All operating parameters, including "Typicals" must be validated for each customer application by customer's technical experts. **onsemi** does not convey any license under any of its intellectual property rights nor the rights of others. **onsemi** products are not designed, intended, or authorized for use as a critical component in life support systems or any FDA Class 3 medical devices or medical devices with a same or similar classification in a foreign jurisdiction or any devices intended for implantation in the human body. Should Buyer purchase or use **onsemi** products for any such unintended or unauthorized application, Buyer shall indemnify and hold **onsemi** and its officers, employees, subsidiaries, affiliates, and distributors harmless against all claims, costs, damages, and expenses, and reasonable attorney fees arising out of, directly or indirectly, any claim of personal injury or death associated with such unintended or unauthorized use, even if such claim alleges that **onsemi** was negligent regarding the design or manufacture of the part. **onsemi** is an Equal Opportunity/Affirmative Action Employer. This literature is subject to all applicable copyright laws and is not for resale in any manner.

ADDITIONAL INFORMATION

TECHNICAL PUBLICATIONS:

Technical Library: www.onsemi.com/design/resources/technical-documentation
onsemi Website: www.onsemi.com

ONLINE SUPPORT: www.onsemi.com/support

For additional information, please contact your local Sales Representative at www.onsemi.com/support/sales



Looking for pricing, stock, or lifecycle information?

Click below to explore more details on WIN SOURCE:

 [View NLSV4T3144MUTAG on WIN SOURCE](#)

 [ON Semiconductor](#) Information

Optimize Your Supply Chain with WIN SOURCE Solutions

-  Global Sourcing Solution
-  Obsolete Management
-  Cost Control Management
-  Shortage Management
-  Alternative Solution
-  Excess Inventory Management