



# THE DATASHEET OF PCM5102PWR



## 2V<sub>RMS</sub> DirectPath™, 112/106/100dB Audio Stereo DAC with 32-bit, 384kHz PCM Interface

 Check for Samples: [PCM5100](#), [PCM5101](#), [PCM5102](#)

### FEATURES

- Market-Leading Low Out-of-Band Noise
- Selectable Digital-Filter Latency and Performance
- No DC Blocking Capacitors Required
- Integrated Negative Charge Pump
- Internal Pop-Free Control For Sample-Rate Changes Or Clock Halts
- Intelligent Muting System; Soft Up or Down Ramp and Analog Mute For 120dB Mute SNR With Popless Operation.
- Integrated High-Performance Audio PLL With BCK Reference To Generate SCK Internally
- Small 20-pin TSSOP Package

### Typical Performance (3.3V Power Supply)

Parameter	PCM5102 / PCM5101 / PCM5100
SNR	112 / 106 / 100dB
Dynamic Range	112 / 106 / 100dB
THD+N @ -1dBFS	-93 / -92 / -90dB
Full Scale Output	2.1V <sub>RMS</sub> (GND center)
Normal 8x Oversampling Digital Filter Latency: 20/f <sub>s</sub>	
Low Latency 8x Oversampling Digital Filter Latency: 3.5/f <sub>s</sub>	
Sampling Frequency	8kHz to 384kHz
System Clock Multiples (f <sub>SCK</sub> ): 64, 128, 192, 256, 384, 512, 768, 1024, 1152, 1536, 2048, 3072; up to 50 MHz	

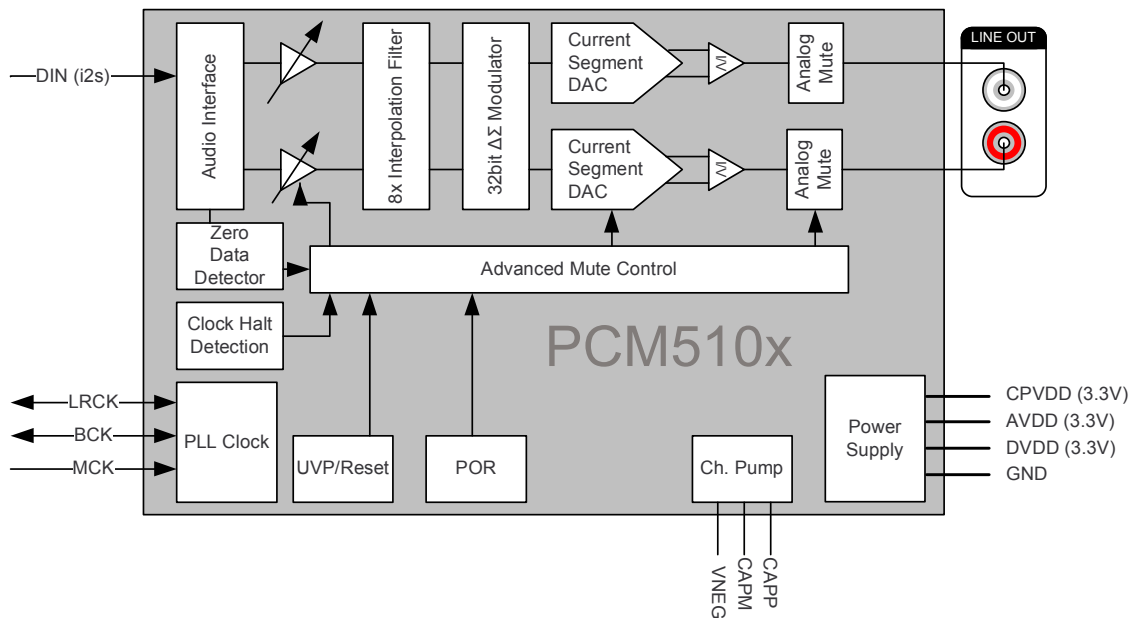

Figure 1. PCM510x Functional Block Diagram

### OTHER KEY FEATURES

- Accepts 16-, 24-, And 32-Bit Audio Data
- PCM Data Formats: I<sup>2</sup>S, Left-Justified
- Automatic Power-Save Mode When LRCK And BCK Are Deactivated.
- 3.3V Failsafe LVCMOS Digital Inputs
- Hardware Configuration
- Single Supply Operation:
  - 3.3V Analog, 3.3V Digital
- Integrated Power-On Reset



Please be aware that an important notice concerning availability, standard warranty, and use in critical applications of Texas Instruments semiconductor products and disclaimers thereto appears at the end of this data sheet.

System Two Cascade, Audio Precision are trademarks of Audio Precision.

DirectPath is a trademark of Texas, Instruments, Inc..



This integrated circuit can be damaged by ESD. Texas Instruments recommends that all integrated circuits be handled with appropriate precautions. Failure to observe proper handling and installation procedures can cause damage.

ESD damage can range from subtle performance degradation to complete device failure. Precision integrated circuits may be more susceptible to damage because very small parametric changes could cause the device not to meet its published specifications.

## APPLICATIONS

- **A/V Receivers**
- **DVD, BD Players**
- **HDTV Receivers**
- **Applications Requiring 2V<sub>RMS</sub> Audio Output**

## DESCRIPTION

The PCM510x devices are a family of monolithic CMOS integrated circuits that include a stereo digital-to-analog converter and additional support circuitry in a small TSSOP package. The PCM510x uses the latest generation of TI's advanced segment-DAC architecture to achieve excellent dynamic performance and improved tolerance to clock jitter.

The PCM510x provides 2.1V<sub>RMS</sub> ground centered outputs, allowing designers to eliminate DC blocking capacitors on the output, as well as external muting circuits traditionally associated with single supply line drivers.

The integrated line driver surpasses all other charge-pump based line drivers by supporting loads down to 1kΩ. By supporting loads down to 1kΩ, the PCM510x can essentially drive up to 10 products in parallel, such as an LCD TV, DVDR, AV Receivers and other devices.

The integrated PLL on the device removes the requirement for a system clock (commonly known as master clock), allowing a 3-wire I<sup>2</sup>S connection and reducing system EMI.

Intelligent clock error and PowerSense under voltage protection utilizes a two level mute system for pop-free performance. Upon clock error or system power failure, the device digitally attenuates the data (or last known good data), then mutes the analog circuit

Compared with existing DAC technology, the PCM510x family offers up to 20dB lower out-of-band noise, reducing EMI and aliasing in downstream amplifiers/ADCs. (from traditional 100kHz OBN measurements all the way to 3MHz)

The PCM510x accepts industry-standard audio data formats with 16- to 32-bit data. Sample rates up to 384kHz are supported.

**Table 1. Differences Between PCM510x Devices**

Part Number	Dynamic Range	SNR	THD
PCM5102	112dB	112dB	-93dB
PCM5101	106dB	106dB	-92dB
PCM5100	100dB	100dB	-90dB



This integrated circuit can be damaged by ESD. Texas Instruments recommends that all integrated circuits be handled with appropriate precautions. Failure to observe proper handling and installation procedures can cause damage.

ESD damage can range from subtle performance degradation to complete device failure. Precision integrated circuits may be more susceptible to damage because very small parametric changes could cause the device not to meet its published specifications.

## DEVICE INFORMATION

### TERMINAL FUNCTIONS, PCM510x

**PCM510x (top view)**

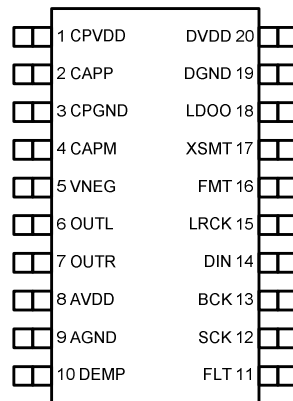

**Table 2. TERMINAL FUNCTIONS, PCM510x**

TERMINAL		I/O	DESCRIPTION
NAME	NO.		
CPVDD	1	—	Charge pump power supply, 3.3V
CAPP	2	O	Charge pump flying capacitor terminal for positive rail
CPGND	3	—	Charge pump ground
CAPM	4	O	Charge pump flying capacitor terminal for negative rail
VNEG	5	O	Negative charge pump rail terminal for decoupling, -3.3V
OUTL	6	O	Analog output from DAC left channel
OUTR	7	O	Analog output from DAC right channel
AVDD	8	—	Analog power supply, 3.3V
AGND	9	—	Analog ground
DEMP	10	I	De-emphasis control for 44.1kHz sampling rate <sup>(1)</sup> : Off (Low) / On (High)
FLT	11	I	Filter select : Normal latency (Low) / Low latency (High)
SCK	12	I	System clock input <sup>(1)</sup>
BCK	13	I	Audio data bit clock input <sup>(1)</sup>
DIN	14	I	Audio data input <sup>(1)</sup>
LRCK	15	I	Audio data word clock input <sup>(1)</sup>
FMT	16	I	Audio format selection : I <sup>2</sup> S (Low) / Left justified (High)
XSMT	17	I	Soft mute control <sup>(1)</sup> : Soft mute (Low) / soft un-mute (High)
LDOO	18	—	Internal logic supply rail terminal for decoupling
DGND	19	—	Digital ground
DVDD	20	—	Digital power supply, 3.3V

(1) Failsafe LVCMOS Schmitt trigger input

## ABSOLUTE MAXIMUM RATINGS

over operating free-air temperature range (unless otherwise noted)

	VALUE	UNIT
Supply Voltage AVDD, CPVDD, DVDD	-0.3 to 3.9	V
Digital Input Voltage	-0.3 to 3.9	
Analog Input Voltage	-0.3 to 3.9	
Operating Temperature Range	-25 to 85	°C
Storage Temperature Range	-65 to 150	

## THERMAL CHARACTERISTICS

over operating free-air temperature range (unless otherwise noted)

PARAMETER		TEST CONDITIONS	MIN	TYP	MAX	UNIT
$\theta_{JA}$	Theta JA	High K		91.2		°C/W
$\Psi_{JT}$	Psi JT			1.0		
$\Psi_{JB}$	Psi JB			41.5		
$\theta_{JC}$	Theta JC	Top		25.3		
$\theta_{JB}$	Theta JB			42.0		

## ELECTRICAL CHARACTERISTICS

All specifications at  $T_A = 25^\circ\text{C}$ ,  $AV_{DD} = CPV_{DD} = DV_{DD} = 3.3\text{V}$ ,  $f_S = 48\text{kHz}$ , system clock =  $512 f_S$  and 24-bit data unless otherwise noted.

PARAMETER	TEST CONDITIONS	MIN	TYP	MAX	UNIT
Resolution		16	24	32	Bits
<b>Data Format (PCM Mode)</b>					
	Audio data interface format		I <sup>2</sup> S, left justified		
	Audio data bit length		16, 24, 32-bit acceptable		
	Audio data format		MSB First, 2's Complement		
$f_S^{(1)}$	Sampling frequency	8		384	kHz
	System clock frequency		64, 128, 192, 256, 384, 512, 768, 1024, 1152, 1536, 2048, or 3072 $f_{SCK}$ , up to 50Mhz		
<b>Digital Input/Output</b>					
Logic Family: 3.3V LVCMOS compatible					
$V_{IH}$	Input logic level		0.7×DV <sub>DD</sub>		V
$V_{IL}$			0.3×DV <sub>DD</sub>		
$I_{IH}$	Input logic current	$V_{IN} = V_{DD}$		10	μA
$I_{IL}$		$V_{IN} = 0\text{V}$		-10	
$V_{OH}$	Output logic level	$I_{OH} = -4\text{mA}$	0.8×DV <sub>DD</sub>		V
$V_{OL}$		$I_{OL} = 4\text{mA}$	0.22×DV <sub>DD</sub>		

(1) One sample time  $t_s$  defined as the reciprocal of the sampling frequency.  $t_s = 1/f_S$

**ELECTRICAL CHARACTERISTICS (continued)**

All specifications at  $T_A = 25^\circ\text{C}$ ,  $AV_{DD} = CPV_{DD} = DV_{DD} = 3.3\text{V}$ ,  $f_S = 48\text{kHz}$ , system clock =  $512 f_S$  and 24-bit data unless otherwise noted.

PARAMETER	TEST CONDITIONS	MIN	TYP	MAX	UNIT
<b>Dynamic Performance (PCM Mode)<sup>(2)(3)</sup> (Values shown for three devices PCM5102/PCM5101/PCM5100)</b>					
THD+N at $-1\text{ dBFS}^{(3)}$	$f_S = 48\text{kHz}$		$-93/-92/-90$	$-83/-82/-80$	dB
	$f_S = 96\text{kHz}$		$-93/-92/-90$		
	$f_S = 192\text{kHz}$		$-93/-92/-90$		
Dynamic range <sup>(3)</sup>	EIAJ, A-weighted, $f_S = 48\text{kHz}$	106/ 100/ 95	112/106/100		
	EIAJ, A-weighted, $f_S = 96\text{kHz}$		112/106/100		
	EIAJ, A-weighted, $f_S = 192\text{kHz}$		112/106/100		
Signal-to-noise ratio <sup>(3)</sup>	EIAJ, A-weighted, $f_S = 48\text{kHz}$		112/106/100		
	EIAJ, A-weighted, $f_S = 96\text{kHz}$		112/106/100		
	EIAJ, A-weighted, $f_S = 192\text{kHz}$		112/106/100		
Signal to noise ratio with analog mute <sup>(3)(4)</sup>	EIAJ, A-weighted, $f_S = 48\text{kHz}$	113	123		
	EIAJ, A-weighted, $f_S = 96\text{kHz}$		123		
	EIAJ, A-weighted, $f_S = 192\text{kHz}$		123		
Channel Separation	$f_S = 48\text{ kHz}$	100/ 95/ 90	109/103/97		
	$f_S = 96\text{kHz}$		109/103/97		
	$f_S = 192\text{kHz}$		109/103/97		
<b>Analog Output</b>					
Output voltage			2.1		$V_{RMS}$
Gain error		-6	$\pm 2.0$	6	% of FSR
Gain mismatch, channel-to-channel		-6	$\pm 2.0$	6	% of FSR
Bipolar zero error	At bipolar zero	-5	$\pm 1.0$	5	mV
Load impedance		1			k $\Omega$
<b>Filter Characteristics–1: Normal</b>					
Pass band				$0.45f_S$	
Stop band		$0.55f_S$			
Stop band attenuation		-60			dB
Pass-band ripple				$\pm 0.02$	
Delay time			$20/f_S$		s
<b>Filter Characteristics–2: Low Latency</b>					
Pass band				$0.47f_S$	
Stop band		$0.55f_S$			
Stop band attenuation		-52			dB
Pass-band ripple				$\pm 0.0001$	
Delay time			$3.5/f_S$		s

(2) Filter condition: THD+N: 20Hz HPF, 20kHz AES17 LPF Dynamic range: 20Hz HPF, 20kHz AES17 LPF, A-weighted Signal-to-noise ratio: 20Hz HPF, 20kHz AES17 LPF, A-weighted Channel separation: 20Hz HPF, 20kHz AES17 LPF Analog performance specifications are measured using the System Two Cascade™ audio measurement system by Audio Precision™ in the RMS mode.

(3) Output load is 10k $\Omega$ , with 470 $\Omega$  output resistor and a 2.2nF shunt capacitor (see recommended output filter).

(4) Assert XSMT or both L-ch and R-ch PCM data are BPZ

**ELECTRICAL CHARACTERISTICS (continued)**

All specifications at  $T_A = 25^\circ\text{C}$ ,  $AV_{DD} = CPV_{DD} = DV_{DD} = 3.3\text{V}$ ,  $f_S = 48\text{kHz}$ , system clock =  $512 f_S$  and 24-bit data unless otherwise noted.

PARAMETER	TEST CONDITIONS	MIN	TYP	MAX	UNIT	
<b>Power Supply Requirements</b>						
$DV_{DD}$	Digital supply voltage	Target $DV_{DD} = 3.3\text{V}$	3.0	3.3	3.6	VDC
$AV_{DD}$	Analog supply voltage		3.0	3.3	3.6	
$CPV_{DD}$	Charge-pump supply voltage		3.0	3.3	3.6	
$I_{DD}$	$DV_{DD}$ supply current at $3.3\text{V}^{(5)}$	$f_S = 48\text{kHz}$		7	12	mA
		$f_S = 96\text{kHz}$		8		
		$f_S = 192\text{kHz}$		9		
$I_{DD}$	$DV_{DD}$ supply current at $3.3\text{V}^{(6)}$	$f_S = 48\text{kHz}$		8	13	mA
		$f_S = 96\text{kHz}$		9		
		$f_S = 192\text{kHz}$		10		
$I_{DD}$	$DV_{DD}$ supply current at $3.3\text{V}^{(7)}$			0.5	0.8	mA
$I_{CC}$	$AV_{DD} / CPV_{DD}$ Supply Current <sup>(5)</sup>	$f_S = 48\text{kHz}$		11	16	mA
		$f_S = 96\text{kHz}$		11		
		$f_S = 192\text{kHz}$		11		
$I_{CC}$	$AV_{DD} / CPV_{DD}$ Supply Current <sup>(6)</sup>	$f_S = 48\text{kHz}$		22	32	mA
		$f_S = 96\text{kHz}$		22		
		$f_S = 192\text{kHz}$		22		
$I_{CC}$	$AV_{DD} / CPV_{DD}$ Supply Current <sup>(7)</sup>	$f_S = \text{n/a}$		0.2	0.4	mA
	Power Dissipation, $DV_{DD} = 3.3\text{V}^{(5)}$	$f_S = 48\text{kHz}$		59.4	92.4	mW
		$f_S = 96\text{kHz}$		62.7		
		$f_S = 192\text{kHz}$		66.0		
	Power Dissipation, $DV_{DD} = 3.3\text{V}^{(6)}$	$f_S = 48\text{kHz}$		99.0	148.5	mW
		$f_S = 96\text{kHz}$		102.3		
		$f_S = 192\text{kHz}$		105.6		
	Power Dissipation, $DV_{DD} = 3.3\text{V}^{(7)}$	$f_S = \text{n/a}$ (Power Down Mode)		2.3	4.0	mW

(5) Input is Bipolar Zero data.

(6) Input is 1kHz -1dBFS data

(7) Power Down Mode

**TYPICAL CHARACTERISTICS**

All specifications at  $T_A = 25^\circ\text{C}$ ,  $AV_{DD} = CPV_{DD} = DV_{DD} = 3.3\text{V}$ ,  $f_S = 48\text{kHz}$ , system clock =  $512 f_S$  and 24-bit data unless otherwise noted.

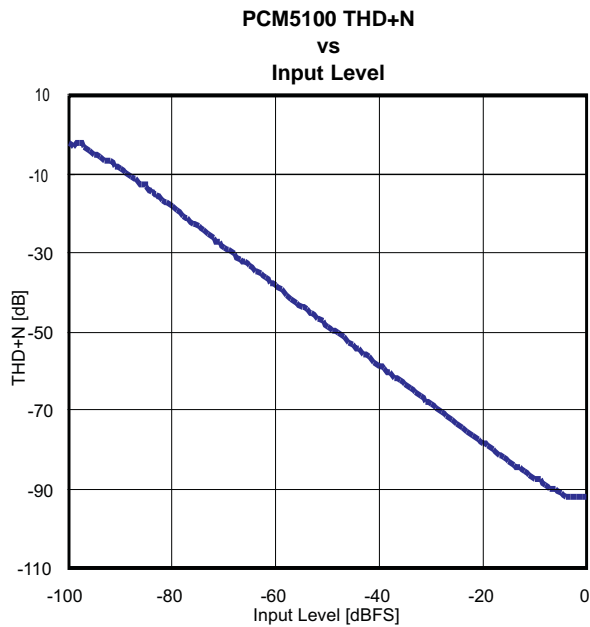

**Figure 2.**

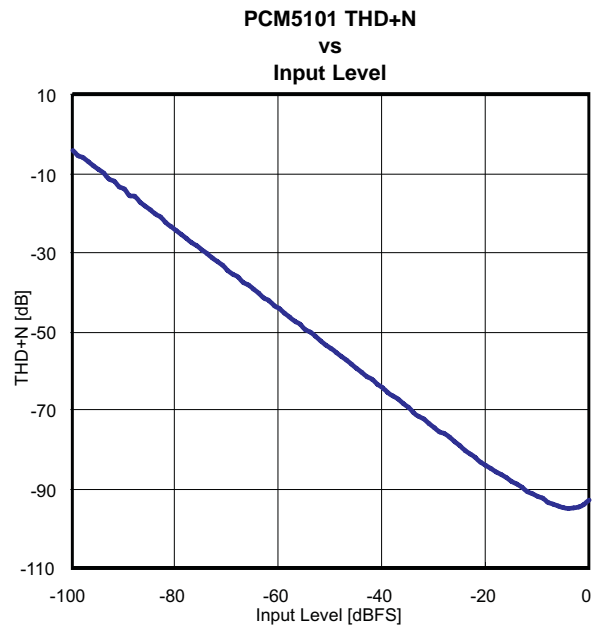

**Figure 3.**

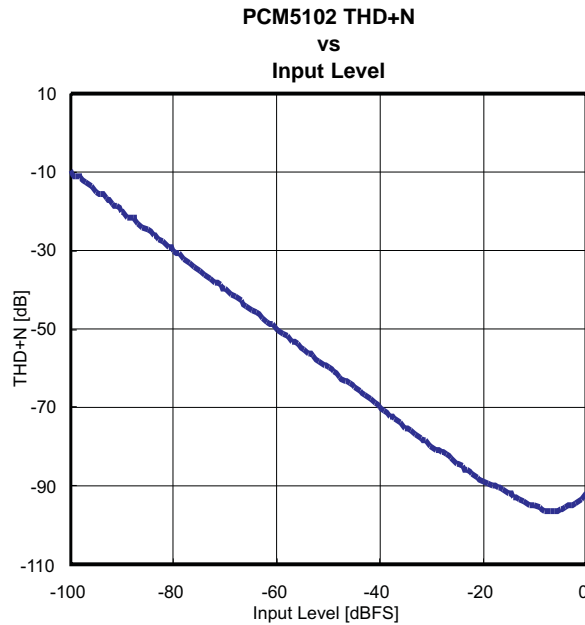

**Figure 4.**

**TYPICAL CHARACTERISTICS (continued)**

All specifications at  $T_A = 25^\circ\text{C}$ ,  $AV_{DD} = CPV_{DD} = DV_{DD} = 3.3\text{V}$ ,  $f_s = 48\text{kHz}$ , system clock =  $512 f_s$  and 24-bit data unless otherwise noted.

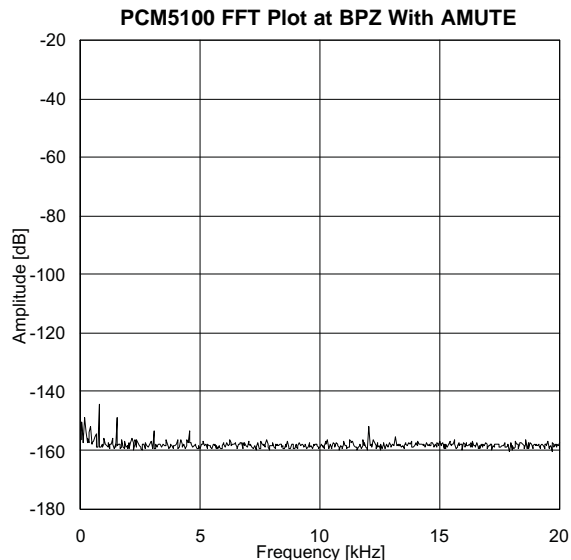

Figure 5.

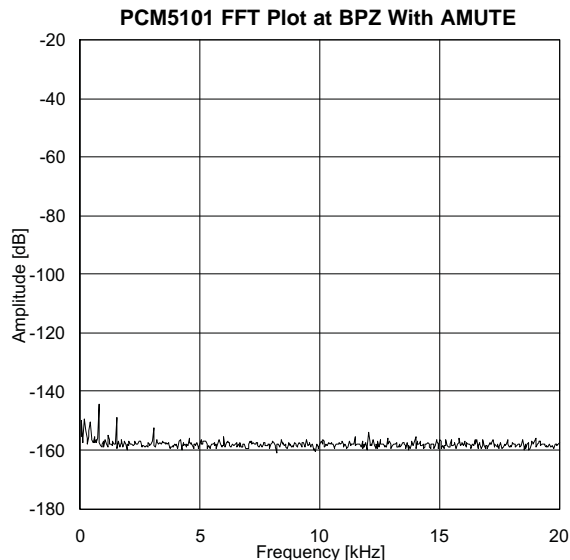

Figure 6.

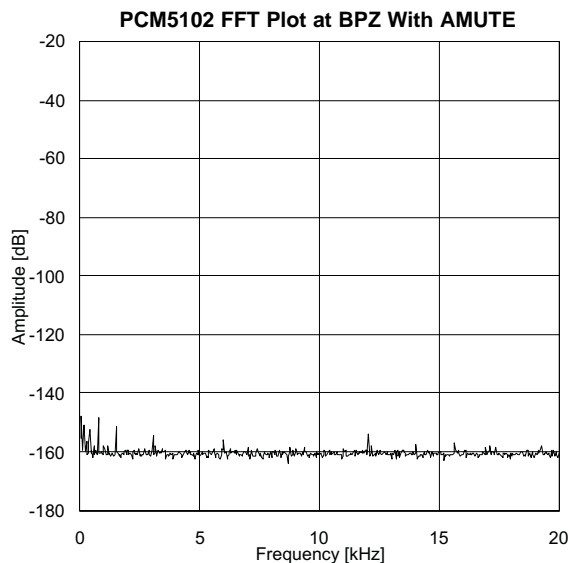
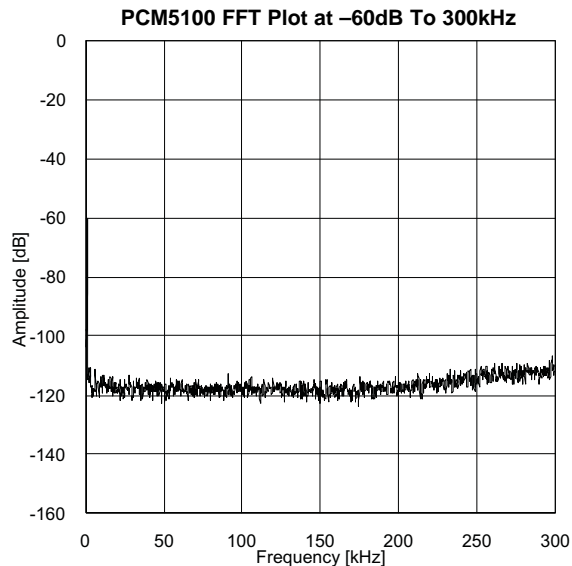

Figure 7.

**TYPICAL CHARACTERISTICS (continued)**

All specifications at  $T_A = 25^\circ\text{C}$ ,  $AV_{DD} = CPV_{DD} = DV_{DD} = 3.3\text{V}$ ,  $f_S = 48\text{kHz}$ , system clock =  $512 f_S$  and 24-bit data unless otherwise noted.



**Figure 8.**

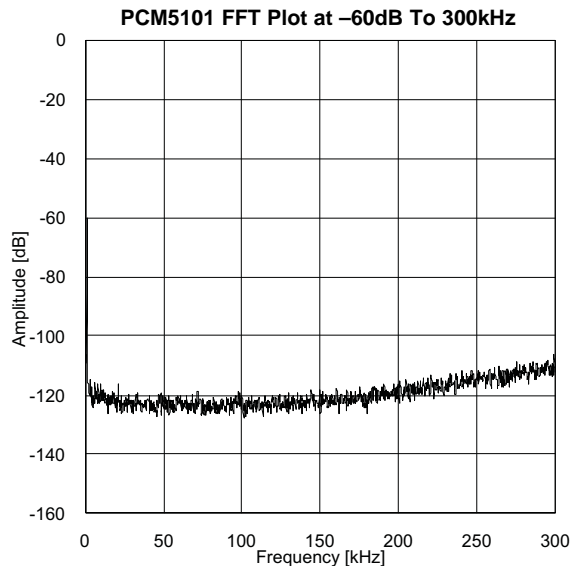

**Figure 9.**

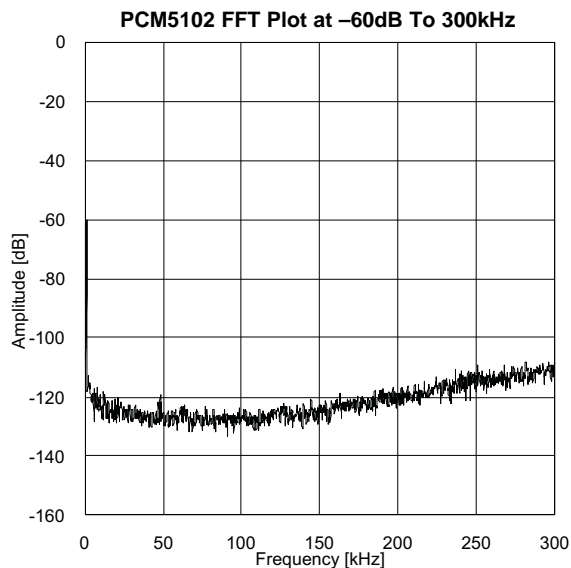

**Figure 10.**

## APPLICATION INFORMATION

### Reset and System Clock Functions

#### Power-On Reset Function

The PCM510x includes a power-on reset function shown in Figure 11. With  $V_{DD} > 2.8V$ , the power-on reset function is enabled. After the initialization period, the PCM510x is set to its default reset state.

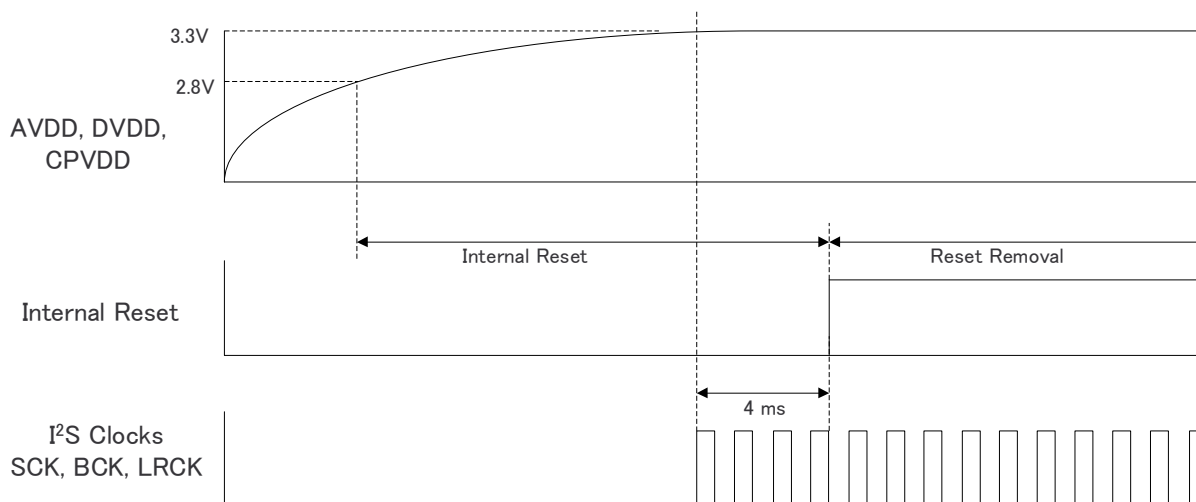

Figure 11. Power-On Reset Timing, DVDD = 3.3V

### System Clock Input

The PCM510x requires a system clock to operate the digital interpolation filters and advanced segment DAC modulators. The system clock is applied at the SCK input (pin 12) and supports up to 50MHz. The PCM510x system-clock detection circuit automatically senses the system-clock frequency. Common audio sampling frequencies of 8kHz, 16kHz, 32kHz - 44.1kHz - 48kHz, 88.2kHz - 96kHz, 176.4kHz -192kHz, and 384kHz with  $\pm 4\%$  tolerance are supported. The sampling frequency detector sets the clock for the digital filter, Delta Sigma Modulator (DSM) and the Negative Charge Pump (NCP) automatically. Table 3 shows examples of system clock frequencies for common audio sampling rates.

SCK rates that are not common to standard audio clocks, between 1MHz and 50MHz, are only supported in software mode, available only in the PCM512x and PCM514x devices, by configuring various PLL and clock-divider registers. Software mode allows the device to become a clock master and drive the host SERIAL port with LRCK and BCK, from a non-audio related clock; for example, using 12MHz to generate 44.1kHz (LRCK) and 2.8224MHz (BCK).

Figure 12 shows the timing requirements for the system clock input. For optimal performance, it is important to use a clock source with low phase jitter and noise.

**Table 3. System Master Clock Inputs for Audio Related Clocks**

Sampling Frequency	System Clock Frequency ( $f_{SCK}$ ) (MHz)											
	$64 f_s$	$128 f_s$	$192 f_s$	$256 f_s$	$384 f_s$	$512 f_s$	$768 f_s$	$1024 f_s$	$1152 f_s$	$1536 f_s$	$2048 f_s$	$3072 f_s$
8 kHz	– <sup>(1)</sup>	1.0240 <sup>(2)</sup>	1.5360 <sup>(2)</sup>	2.0480	3.0720	4.0960	6.1440	8.1920	9.2160	12.2880	16.3840	24.5760
16 kHz	– <sup>(1)</sup>	2.0480 <sup>(2)</sup>	3.0720 <sup>(2)</sup>	4.0960	6.1440	8.1920	12.2880	16.3840	18.4320	24.5760	36.8640	49.1520
32 kHz	– <sup>(1)</sup>	4.0960 <sup>(2)</sup>	6.1440 <sup>(2)</sup>	8.1920	12.2880	16.3840	24.5760	32.7680	36.8640	49.1520	– <sup>(1)</sup>	– <sup>(1)</sup>
44.1 kHz	– <sup>(1)</sup>	5.6488 <sup>(2)</sup>	8.4672 <sup>(2)</sup>	11.2896	16.9344	22.5792	33.8688	45.1584	– <sup>(1)</sup>	– <sup>(1)</sup>	– <sup>(1)</sup>	– <sup>(1)</sup>
48 kHz	– <sup>(1)</sup>	6.1440 <sup>(2)</sup>	9.2160 <sup>(2)</sup>	12.2880	18.4320	24.5760	36.8640	49.1520	– <sup>(1)</sup>	– <sup>(1)</sup>	– <sup>(1)</sup>	– <sup>(1)</sup>
88.2 kHz	– <sup>(1)</sup>	11.2896 <sup>(2)</sup>	16.9344	22.5792	33.8688	45.1584	– <sup>(1)</sup>	– <sup>(1)</sup>	– <sup>(1)</sup>	– <sup>(1)</sup>	– <sup>(1)</sup>	– <sup>(1)</sup>
96 kHz	– <sup>(1)</sup>	12.2880 <sup>(2)</sup>	18.4320	24.5760	36.8640	49.1520	– <sup>(1)</sup>	– <sup>(1)</sup>	– <sup>(1)</sup>	– <sup>(1)</sup>	– <sup>(1)</sup>	– <sup>(1)</sup>
176.4 kHz	– <sup>(1)</sup>	22.5792	33.8688	45.1584	– <sup>(1)</sup>	– <sup>(1)</sup>	– <sup>(1)</sup>	– <sup>(1)</sup>	– <sup>(1)</sup>	– <sup>(1)</sup>	– <sup>(1)</sup>	– <sup>(1)</sup>
192 kHz	– <sup>(1)</sup>	24.5760	36.8640	49.1520	– <sup>(1)</sup>	– <sup>(1)</sup>	– <sup>(1)</sup>	– <sup>(1)</sup>	– <sup>(1)</sup>	– <sup>(1)</sup>	– <sup>(1)</sup>	– <sup>(1)</sup>
384 kHz	24.5760	49.1520	– <sup>(1)</sup>	– <sup>(1)</sup>	– <sup>(1)</sup>	– <sup>(1)</sup>	– <sup>(1)</sup>	– <sup>(1)</sup>	– <sup>(1)</sup>	– <sup>(1)</sup>	– <sup>(1)</sup>	– <sup>(1)</sup>

- (1) This system clock rate is not supported for the given sampling frequency.
- (2) This system clock rate is supported by PLL mode.

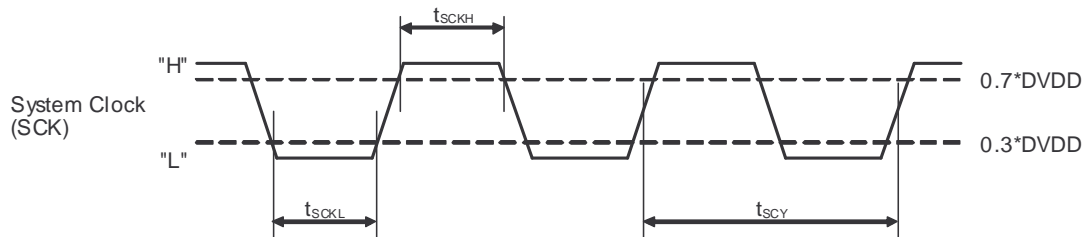

**Figure 12. Timing Requirements for SCK Input**

**Table 4. Timing Requirements for SCK Input**

	Parameters	Min	Max	Unit
t <sub>SCY</sub>	System clock pulse cycle time	20	1000	ns
t <sub>SCKH</sub>	System clock pulse width, High	9		ns
t <sub>SCKL</sub>	System clock pulse width, Low	9		ns

## System Clock PLL Mode

The system clock PLL mode allows designers to use a simple 3-wire I<sup>2</sup>S audio source when driving the DAC. The 3-wire source reduces the need for a high frequency SCK, making PCB layout easier, and reduces high frequency electromagnetic interference.

The device starts up expecting an external SCK input, but if BCK and LRCK start correctly while SCK remains at ground level for 16 successive LRCK periods, then the internal PLL starts, automatically generating an internal SCK from the BCK reference. The PCM510x disables the internal PLL when an external SCK is supplied; specific BCK rates are required to generate an appropriate master clock. Table 5 describes the minimum and maximum BCK per LRCK for the integrated PLL to automatically generate an internal SCK.

**Table 5. BCK Rates (MHz) by LRCK Sample Rate for PCM510x PLL Operation**

Sample f (kHz)	BCK (f <sub>s</sub> )	
	32	64
8	-	-
16	-	1.024
32	1.024	2.048
44.1	1.4112	2.8224
48	1.536	3.072
96	3.072	6.144
192	6.144	12.288
384	12.288	24.576

## Audio Data Interface

### Audio Serial Interface

The audio interface port is a 3-wire serial port, including LRCK (pin 15), BCK (pin 13), and DIN (pin 14). BCK is the serial audio bit clock, used to clock the serial data present on DIN into the serial shift register of the audio interface. Serial data is clocked into the PCM510x on the rising edge of BCK. LRCK is the serial audio left/right word clock.

**Table 6. PCM510x Audio Data Formats, Bit Depths and Clock Rates**

CONTROL MODE	FORMAT	DATA BITS	MAX LRCK FREQUENCY [f <sub>s</sub> ]	SCK RATE [x f <sub>s</sub> ]	BCK RATE [x f <sub>s</sub> ]
Hardware Control	I <sup>2</sup> S/LJ	32, 24, 20, 16	Up to 192kHz	128 – 3072 (≤50MHz)	64, 48, 32
			384kHz	64, 128	64, 48, 32

The PCM510x requires the synchronization of LRCK and system clock, but does not need a specific phase relation between LRCK and system clock.

If the relationship between LRCK and system clock changes more than ±5 SCK, internal operation is initialized within one sample period and analog outputs are forced to the bipolar zero level until resynchronization between LRCK and system clock is completed.

If the relationship between LRCK and BCK are invalid more than 4 LRCK periods, internal operation is initialized within one sample period and analog outputs are forced to the bipolar zero level until resynchronization between LRCK and BCK is completed.

### PCM Audio Data Formats and Timing

The PCM510x supports industry-standard audio data formats, including standard I<sup>2</sup>S and left-justified. Data formats are selected using the FMT (pin 16), Low for I<sup>2</sup>S, and High for Left-justified.

All formats require binary 2s complement, MSB-first audio data. Figure 13 shows a detailed timing diagram for the serial audio interface.

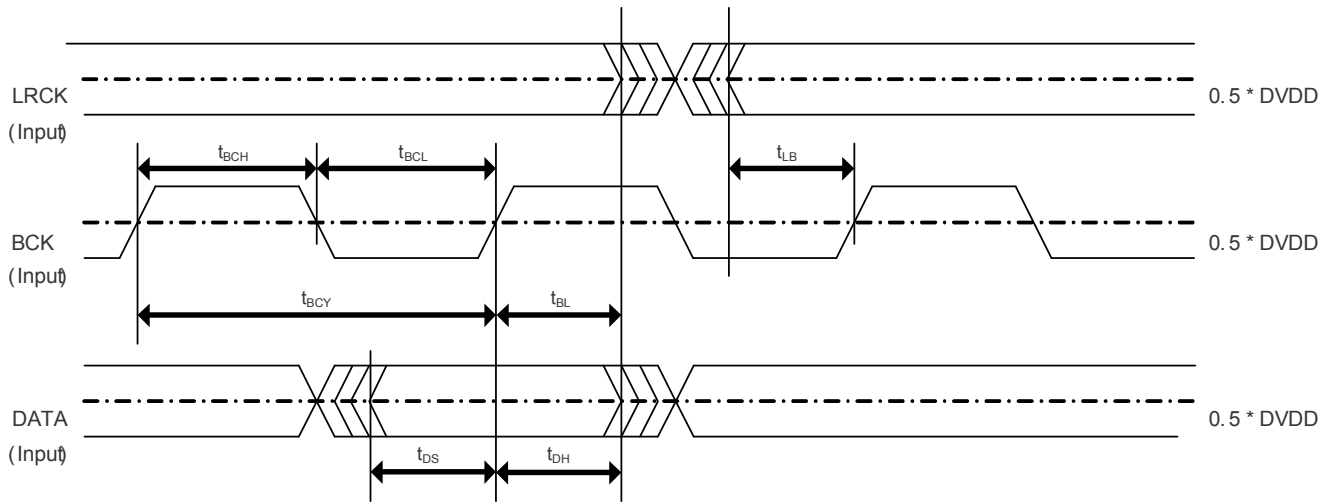

Figure 13. PCM510x Serial Audio Timing - Slave

Table 7. Audio Interface Slave Timing

	Parameters	Min	Max	Units
$t_{BCY}$	BCK Pulse Cycle Time	40		ns
$t_{BCL}$	BCK Pulse Width LOW	16		ns
$t_{BCH}$	BCK Pulse Width HIGH	16		ns
$t_{BL}$	BCK Rising Edge to LRCK Edge	8		ns
$t_{LB}$	LRCK Edge to BCK Rising Edge	8		ns
$t_{DS}$	DATA Set Up Time	8		ns
$t_{DH}$	DATA Hold Time	8		ns
$f_{BCK}$	BCK frequency @ DVDD=3.3V		24.576	MHz

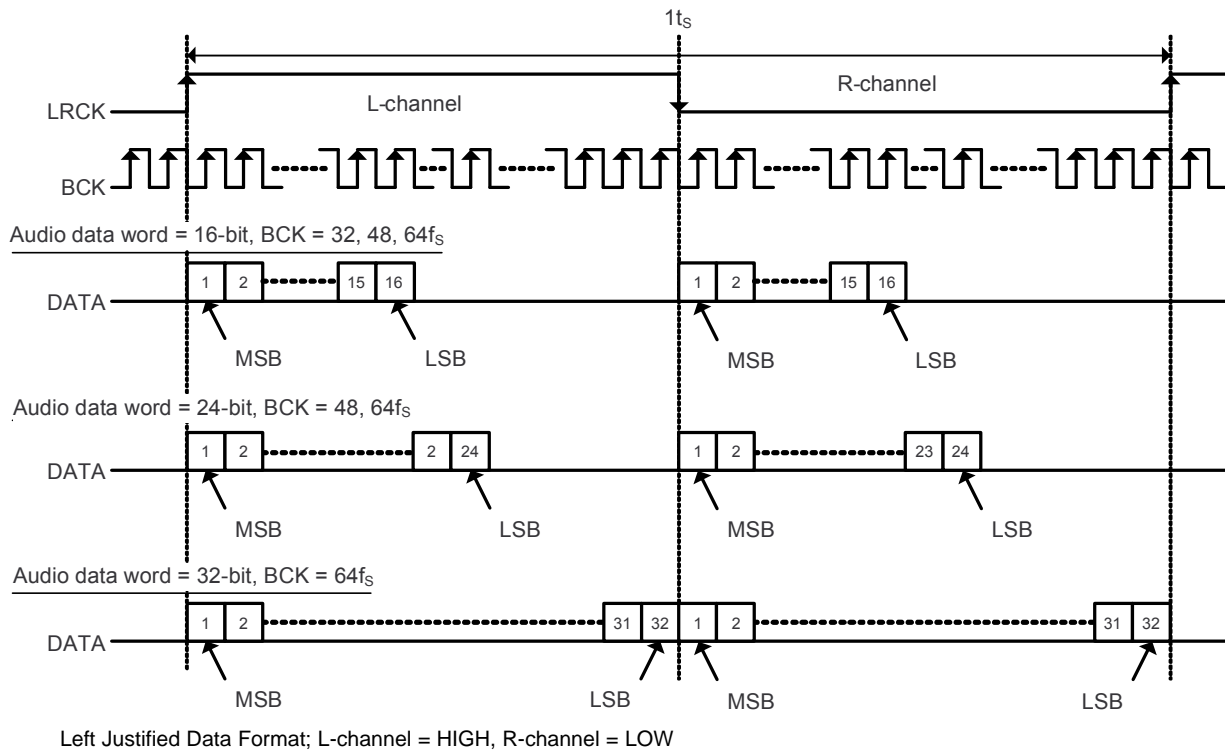

Figure 14. Left Justified Audio Data Format

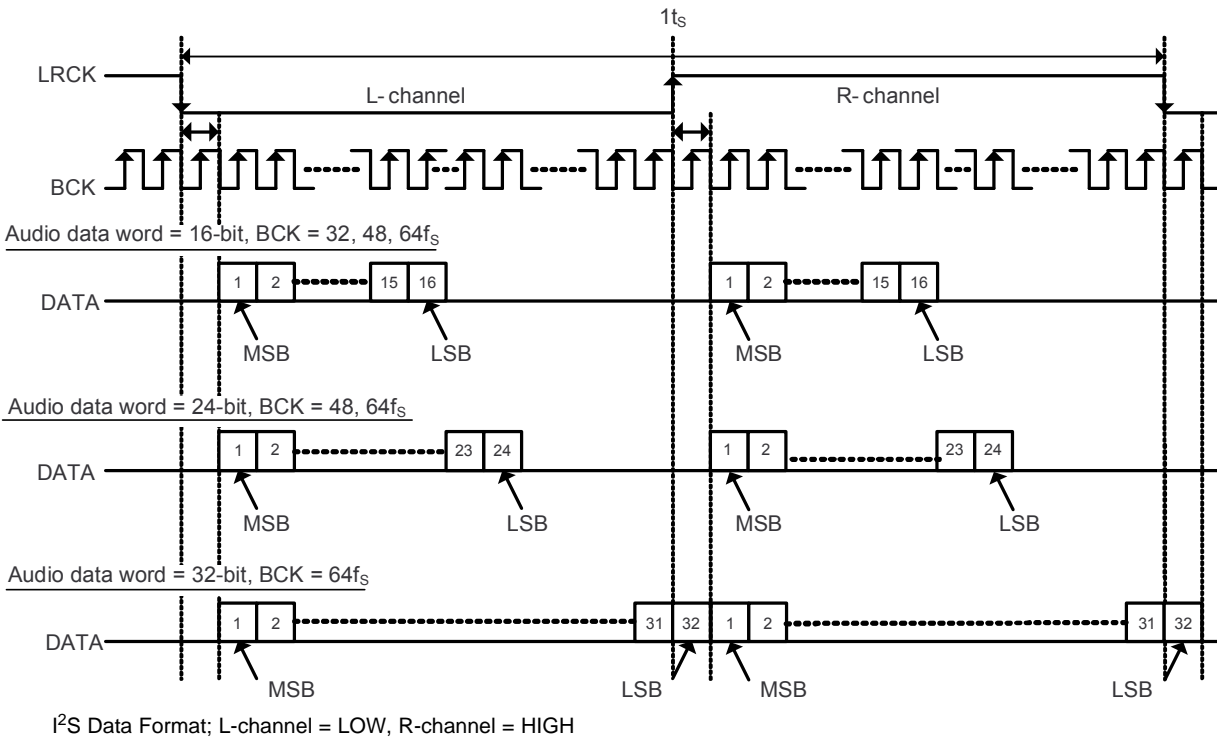

Figure 15. I<sup>2</sup>S Audio Data Format

## Function Descriptions

### Interpolation Filter

The PCM510x provides 2 types of interpolation filter. Users can select which filter to use by using the FLT pin (pin11)

**Table 8. Digital Interpolation Filter Options**

FLT Pin	Description
0	FIR Normal x8/x4/x2/x1 Interpolation Filters
1	IIR Low Latency x8/x4/x2/x1 Interpolation Filters

The Normal x8/x4/x2/x1(bypass) Interpolation filter is programmed in 256 cycles in 1 sample time ( $t_s$ ) for sample rates from 8kHz to 384kHz.

**Table 9. Normal x8 Interpolation Filter**

Parameter	Condition	Value (Typ)	Value (Max)	Units
Filter Gain Pass Band	0 ..... 0.45 $f_s$		$\pm 0.02$	dB
Filter Gain Stop Band	0.55 $f_s$ ..... 7.455 $f_s$	-60		dB
Filter Group Delay		22 $t_s$		s

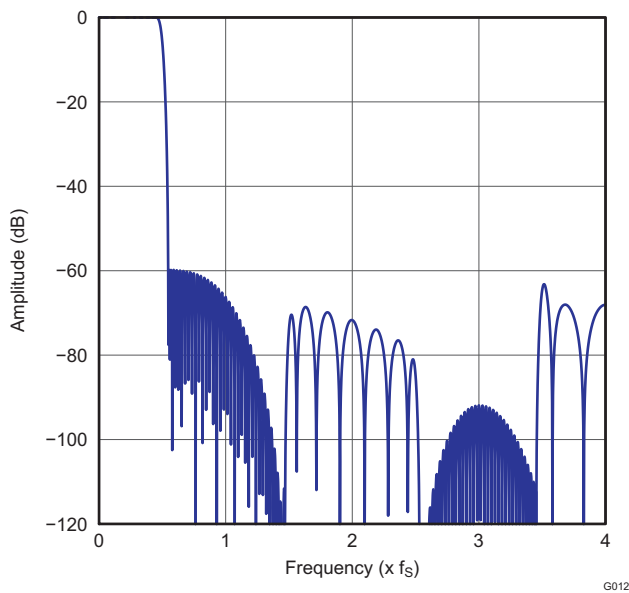

**Figure 16. Normal x8 Interpolation Filter Frequency Response**

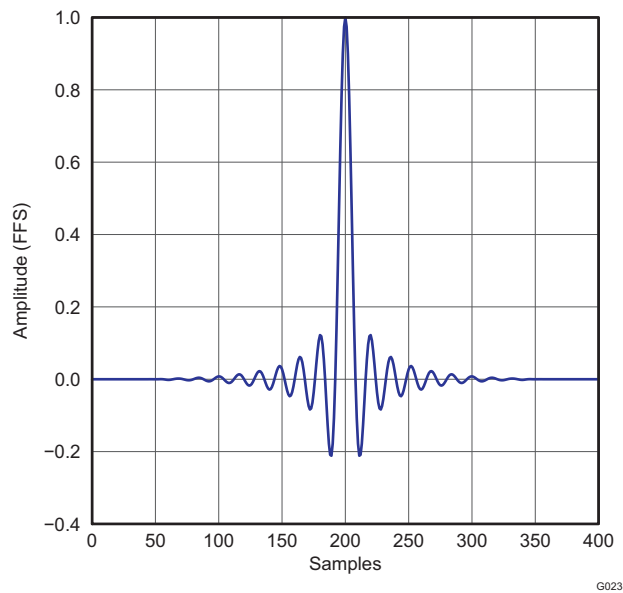

**Figure 17. Normal x8 Interpolation Filter Impulse Response**

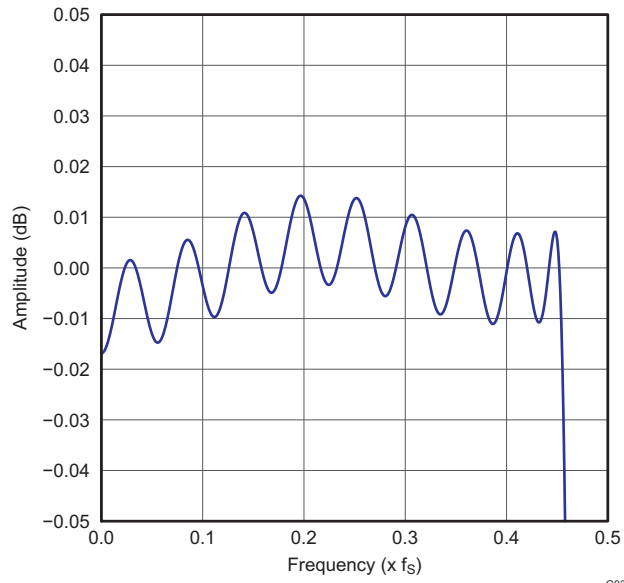
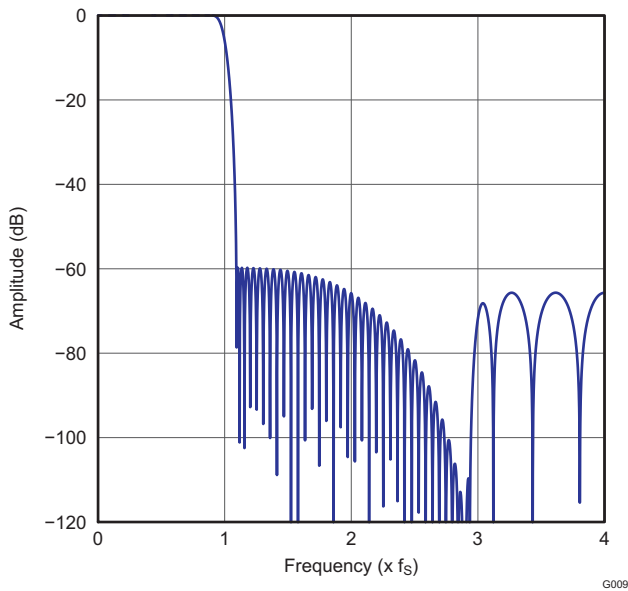

**Figure 18. Normal x8 Interpolation Filter Passband Ripple**

The Normal x4/x2/x1(bypass) Interpolation filter is programmed in 256 cycles in 1 sample time ( $t_s$ ) for sample rates from 8kHz to 384kHz.

**Table 10. Normal x4 Interpolation Filter**

Parameter	Condition	Value (Typ)	Value (Max)	Units
Filter Gain Pass Band	0 ..... 0.45 $f_s$		$\pm 0.02$	dB
Filter Gain Stop Band	0.55 $f_s$ ..... 7.455 $f_s$	-60		dB
Filter Group Delay		22 $t_s$		s



**Figure 19. Normal x4 Interpolation Filter Frequency Response**

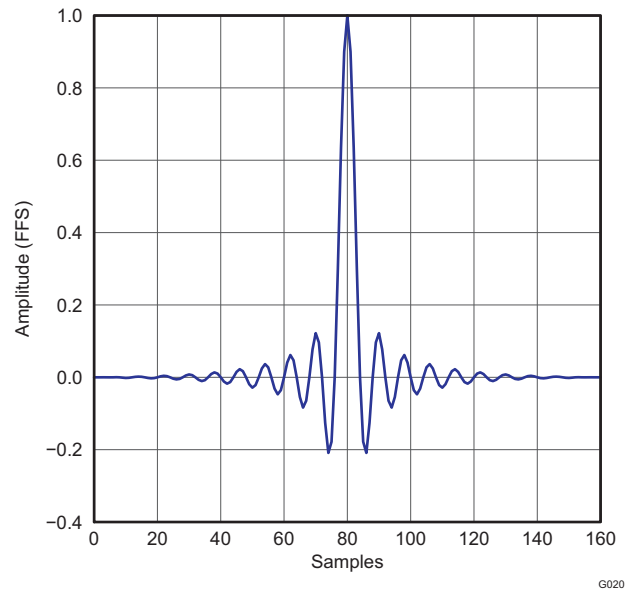

**Figure 20. Normal x4 Interpolation Filter Impulse Response**

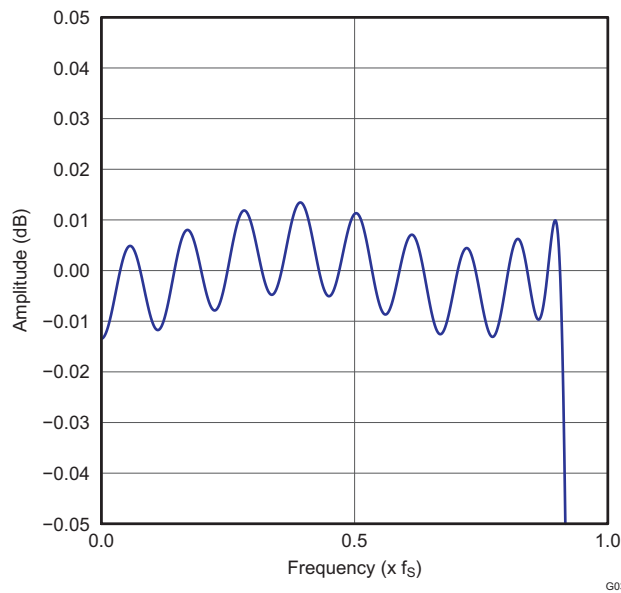
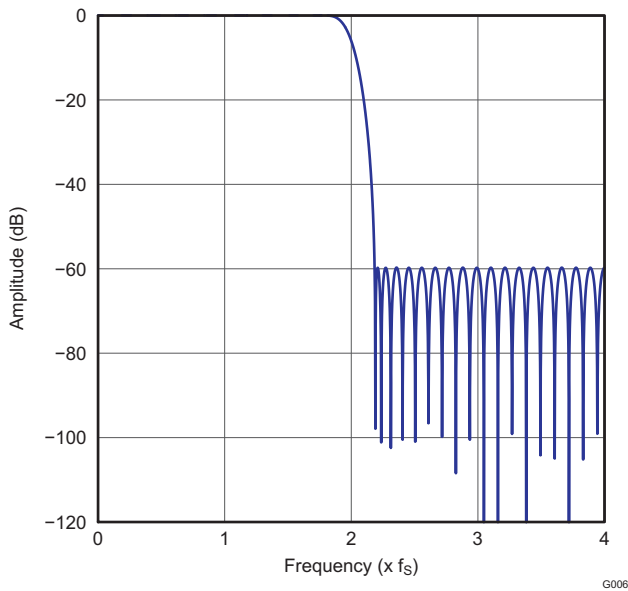

**Figure 21. Normal x4 Interpolation Filter Passband Ripple**

Normal x2 / x1(bypass) Interpolation filter is programmed in 256 cycles in 1 sample time ( $t_s$ ) for sample rates from 8kHz to 384kHz.

**Table 11. Normal x2 Interpolation Filter**

Parameter	Condition	Value (Typ)	Value (Max)	Units
Filter Gain Pass Band	0 ..... 0.45 $f_s$		$\pm 0.02$	dB
Filter Gain Stop Band	0.55 $f_s$ ..... 7.455 $f_s$	-60		dB
Filter Group Delay		22 $t_s$		s



**Figure 22. Normal x2 Interpolation Filter Frequency Response**

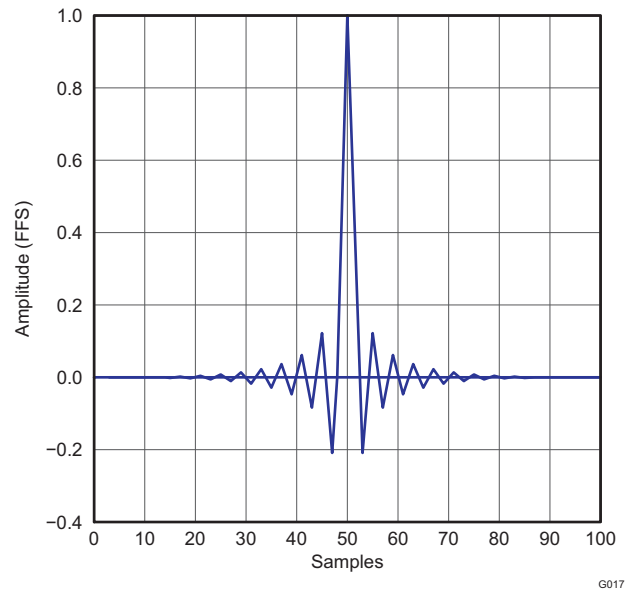

**Figure 23. Normal x2 Interpolation Filter Impulse Response**

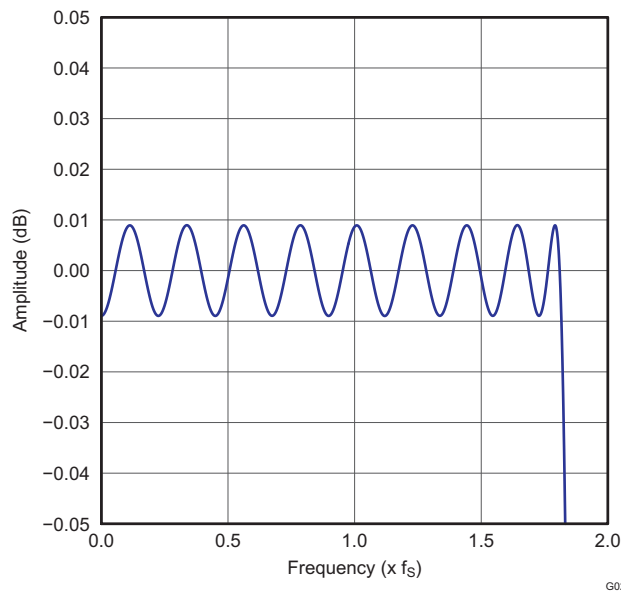
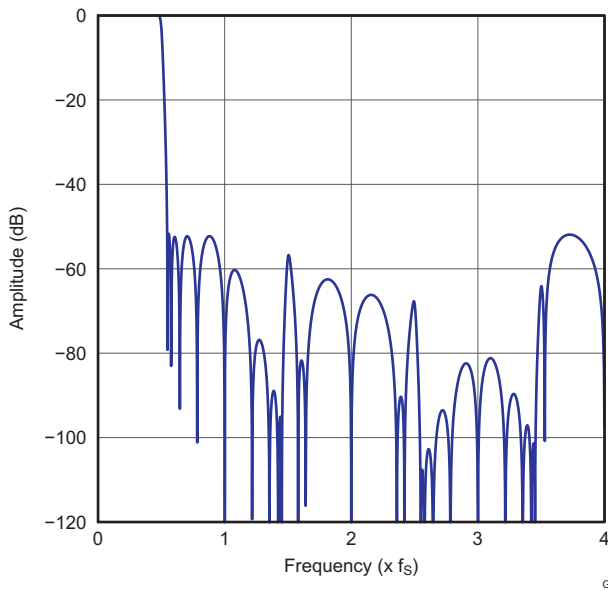

**Figure 24. Normal x2 Interpolation Filter Passband Ripple**

The low-latency x8 / x4 / x2 / x1(bypass) Interpolation filter is programmed in 256 cycles 1 sample time ( $t_s$ ) for sample rates from 8kHz to 384kHz.

**Table 12. Low latency x8 Interpolation Filter**

Parameter	Condition	Value (Typ)	Units
Filter Gain Pass Band	0 ..... 0.45 $f_s$	$\pm 0.0001$	dB
Filter Gain Stop Band	0.55 $f_s$ ..... 7.455 $f_s$	-52	dB
Filter Group Delay		3.5 $t_s$	s



**Figure 25. Low latency x8 Interpolation Filter Frequency Response**

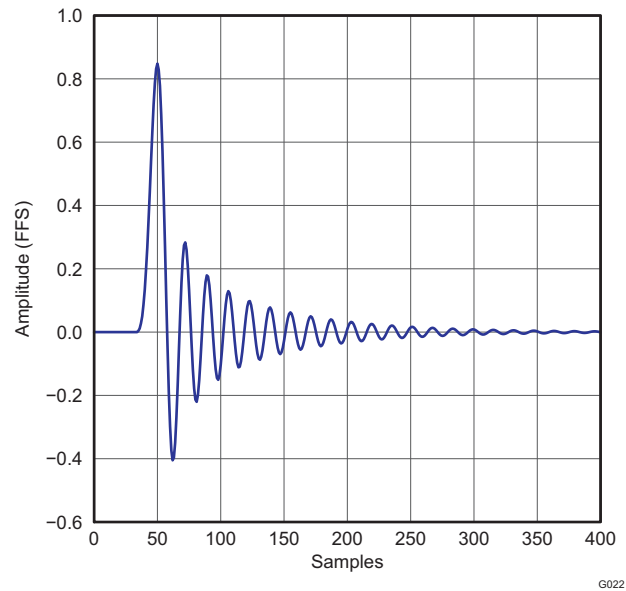

**Figure 26. Low latency x8 Interpolation Filter Impulse Response**

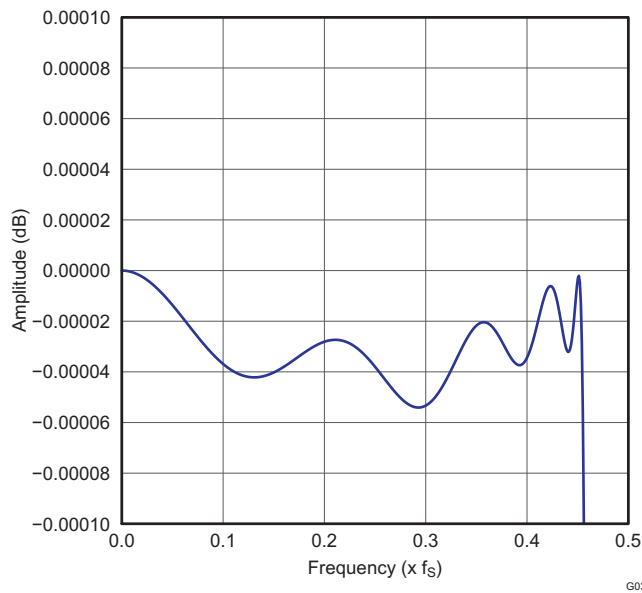

**Figure 27. Low latency x8 Interpolation Filter Passband Ripple**

**Table 13. Low latency x4 Interpolation Filter**

Parameter	Condition	Value (Typ)	Units
Filter Gain Pass Band	0 ..... 0.45f <sub>S</sub>	±0.0001	dB
Filter Gain Stop Band	0.55f <sub>S</sub> ..... 3.455f <sub>S</sub>	-52	dB
Filter Group Delay		3.5t <sub>S</sub>	s

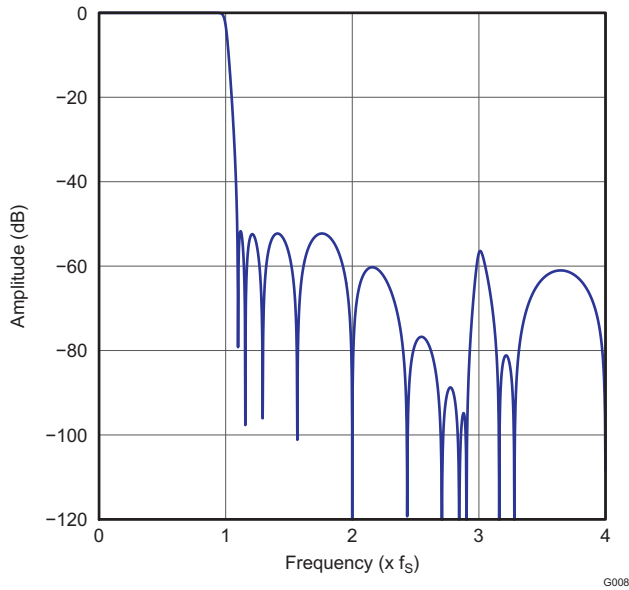

**Figure 28. Low latency x4 Interpolation Filter Frequency Response**

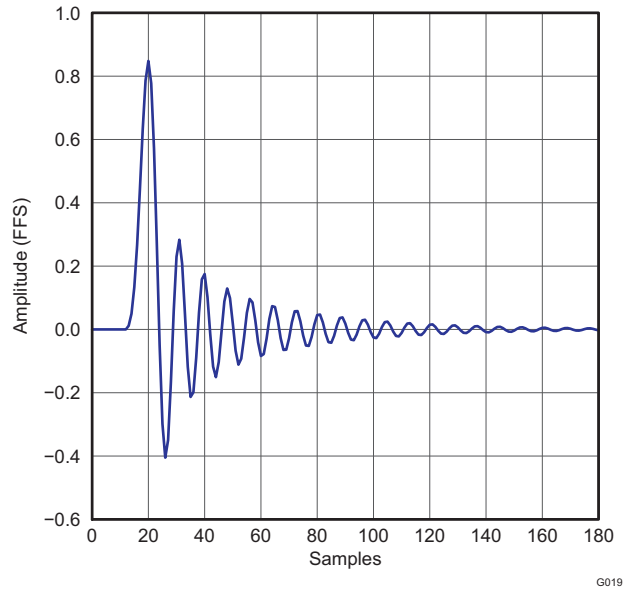

**Figure 29. Low latency x4 Interpolation Filter Impulse Response**

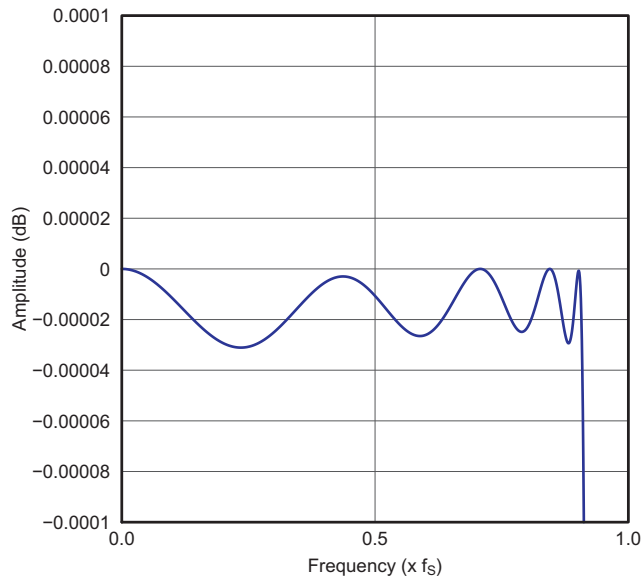

**Figure 30. Low latency x4 Interpolation Filter Passband Ripple**

**Table 14. Low latency x2 Interpolation Filter**

Parameter	Condition	Value (Typ)	Units
Filter Gain Pass Band	0 ..... 0.45f <sub>s</sub>	±0.0001	dB
Filter Gain Stop Band	0.55f <sub>s</sub> ..... 1.455f <sub>s</sub>	-52	dB
Filter Group Delay		3.5f <sub>s</sub>	s

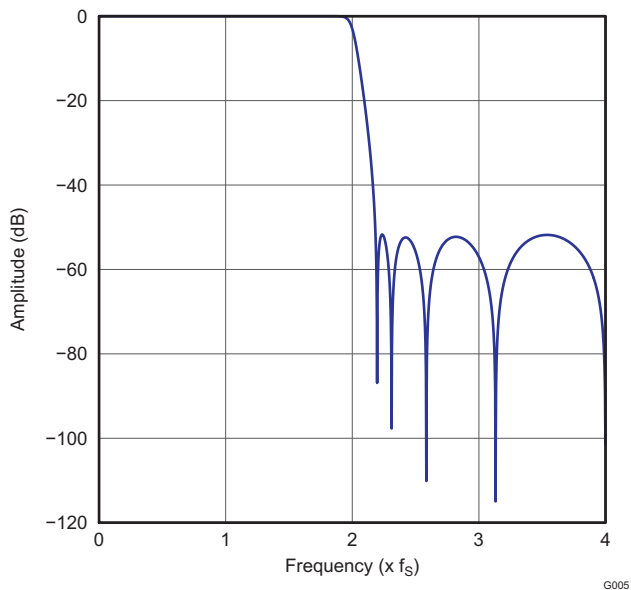

**Figure 31. Low latency x2 Interpolation Filter Frequency Response**

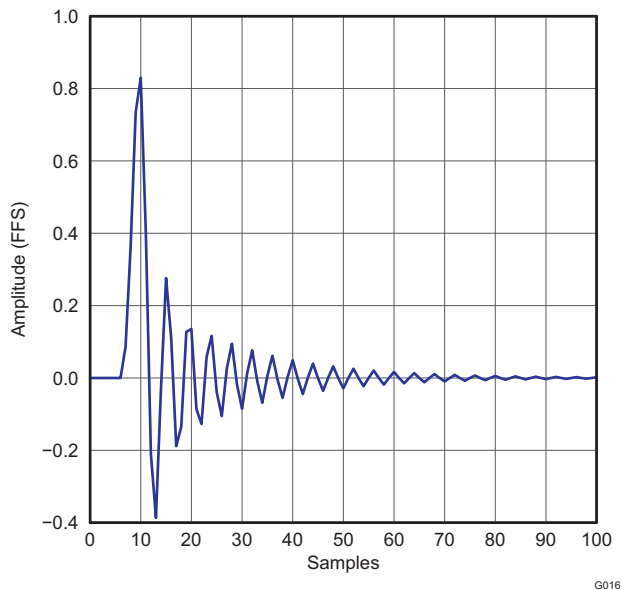

**Figure 32. Low latency x2 Interpolation Filter Impulse Response**

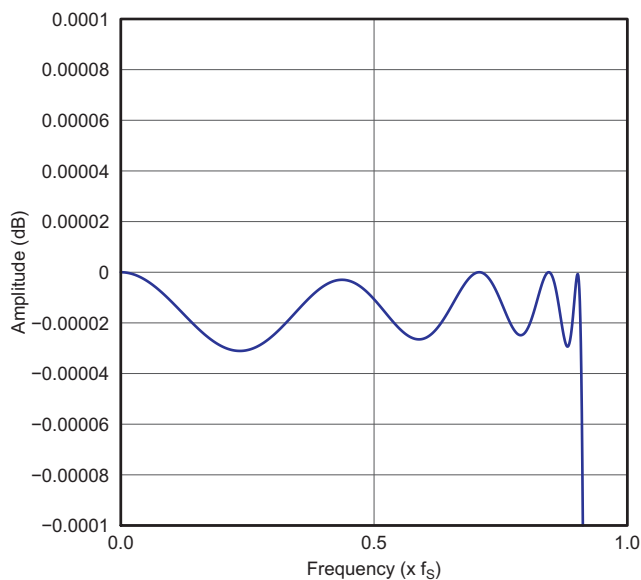

**Figure 33. Low latency x2 Interpolation Filter Passband Ripple**

### Zero Data Detect

The PCM510x has a zero-data detect function. When the device detects continuous zero data, it enters a full analog mute condition.

The PCM510x counts zero data over 1024LRCKs (21ms @ 48kHz) before setting analog mute.

### Power Save Mode

When any kind of clock error (SCK, BCK, and LRCK) or clock halt is detected, the PCM510x enters Stand-by mode automatically. The current-segment DAC and Line driver are also powered down.

When BCK and LRCK halt to a low level for more than 1 second, the PCM510x enters Power down mode automatically. Power-down mode includes the negative charge pump and Bias/Reference circuit power-down in addition to stand-by.

Whenever expected Audio clocks (SCK, BCK, LRCK) are applied to the PCM510x, the device starts its powerup sequence automatically.

### XSMT Pin (Soft Mute and Soft Un-Mute)

For external digital control of the PCM510x, the XSMT pin must be driven by an external digital host with a specific/minimum rise time ( $t_r$ ) and fall time ( $t_f$ ) for soft mute and soft un-mute. The PCM510x requires  $t_r/t_f$  times of less than 20ns. In the majority of applications, this shouldn't be a problem, however, traces with high capacitance may have issues.

When the XSMT pin is shifted from high to low (3.3V to 0V), a soft digital attenuation ramp is started. -1dB attenuation will be applied every  $1t_s$  from 0dBFS to  $-\infty$ . This attenuation takes 104 sample times.

When the XSMT pin is shifted from low to high (0V to 3.3V), a soft digital "un-mute" is started. 1dB gain steps are applied every  $t_s$  from  $-\infty$  to 0dBFS. This ramp-up takes 104 sample times.

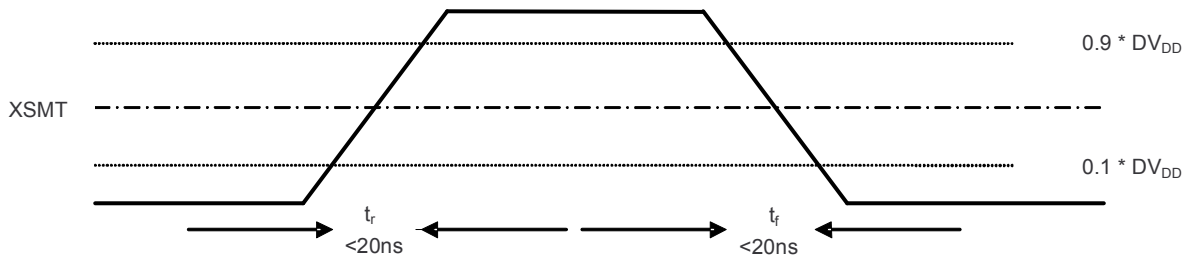

Figure 34. XSMT Timing for Soft Mute and Soft Un-Mute

Table 15. XSMT Timing Parameters

Parameters	Min	Max	Unit
Rise time ( $t_r$ )		20	ns
Fall time ( $t_f$ )		20	ns

### External Power Sense Undervoltage Protection mode (supported only when DVDD = 3.3V)

The XSMT pin can also be used to monitor a system voltage, such as the 24VDC LCD TV backlight, or 12VDC system supply using a potential divider created with two resistors. (See [Figure 35](#) )

- If the XSMT pin makes a transition from 1 to 0 over 6ms or more, the device will switch into external undervoltage protection mode. In this mode, two trigger levels are used.
- When XSMT pin level reaches 2V, soft mute process begins.
- When XSMT pin level reaches 1.2V, analog mute will engage, regardless of digital audio level, and analog shut down will begin. (For example, DAC circuitry powers down).

A timing diagram to show this is shown in [Figure 36](#).

#### NOTE

The XSMT input pins voltage range is from  $-0.3V$  to  $DVDD + 0.3V$ . The ratio of external resistors must be considered within this input range. Any increase in power supply (such as power supply positive noise/ripple) can pull the XSMT pin higher than  $DVDD+0.3V$ .

For example, if the PCM510x is monitoring a 12V input, and dividing the voltage by 4, then the voltage at XSMT during ideal power supply conditions will be 3V. If the voltage spikes any higher than 14.4V, then XSMT will see a voltage in excess of 3.6V ( $DVDD+0.3$ ), potentially damaging the device.

Providing the divider is set appropriately, any DC voltage can be monitored.

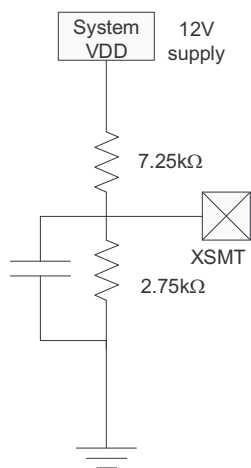

Figure 35. XSMT in External UVP Mode

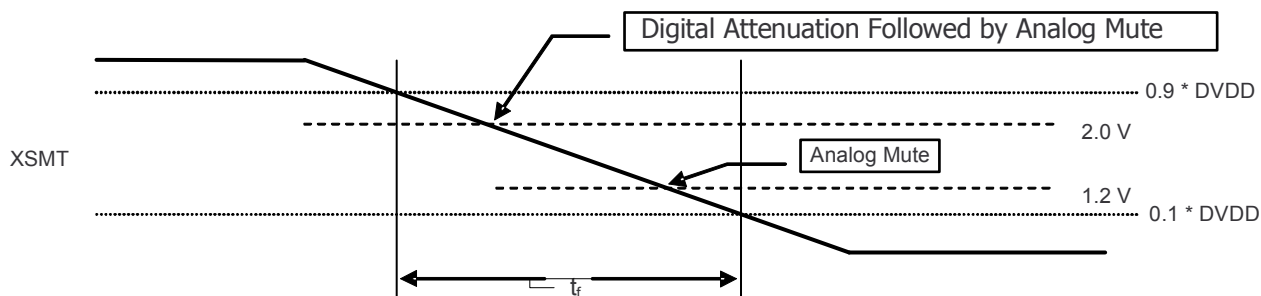

Figure 36. XSMT Timing for Undervoltage Protection

### Recommended Powerdown Sequence

With inadequate system design, the PCM510x can exhibit some pop on power down. Pops are caused by the device not having enough time to detect power loss and start the muting process.

The PCM510x evaluation board avoids audible pop with an electrolytic decoupling capacitor. This capacitor provides enough time between data loss from USB or S/PDIF and power supply loss for the muting process to take place.

The PCM510x has two auto-mute functions to mute the device upon power loss (intentional or unintentional).

#### XSMT = 0

When the XSMT pin is pulled low, the incoming PCM data is attenuated to 0, closely followed by a hard analog mute. This process takes  $150t_s + 0.2mS$ .

As this mute time is mainly dominated by the sampling frequency, systems sampling at 192kHz will mute much faster than a 48kHz system.

#### Clock Error Detect

When clock error is detected on the incoming data clock, the PCM510x family switches to an internal oscillator, and continues to drive the DAC, while attenuating the data from the last known value. Once this process is complete, the PCM510x outputs will be hard muted to ground.

#### Planned Shutdown

These auto-muting processes can be manipulated by system designs to mute before power loss in the following ways:

1. Assert XSMT low  $150t_s + 0.2mS$  before power is removed.

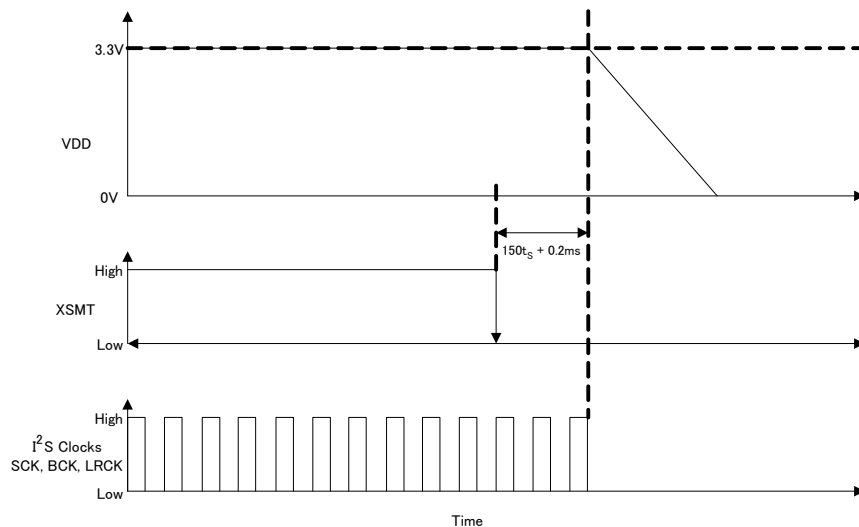

2. Stop I<sup>2</sup>S clocks (SCK, BCK, LRCK) 3ms before powerdown as shown below:

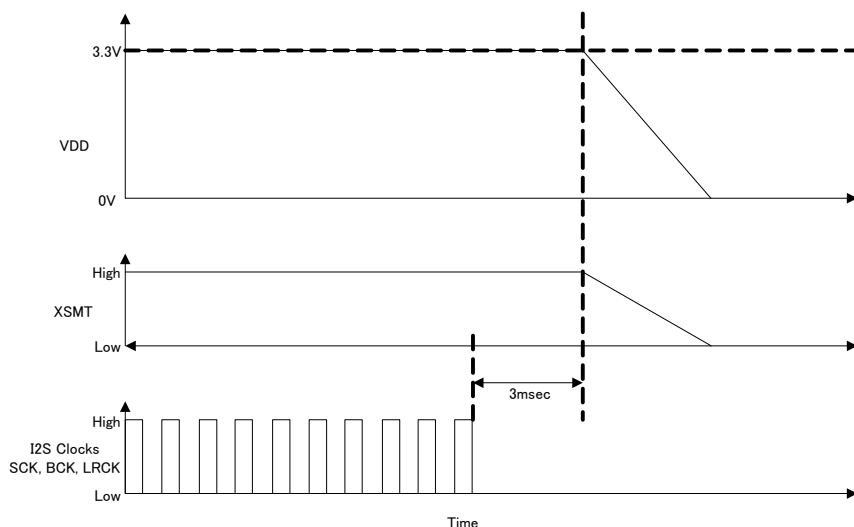

### Unplanned Shutdown

Many systems use a low-noise regulator to provide an AVDD 3.3V supply for the DAC. The XSMT Pin can take advantage of such a feature to measure the pre-regulated output from the system SMPS to mute the DAC before the entire SMPS discharges. Figure 37 shows how to configure such a system to use the XSMT pin. The XSMT pin can also be used in parallel with a GPIO pin from the system microcontroller/DSP or Power Supply.

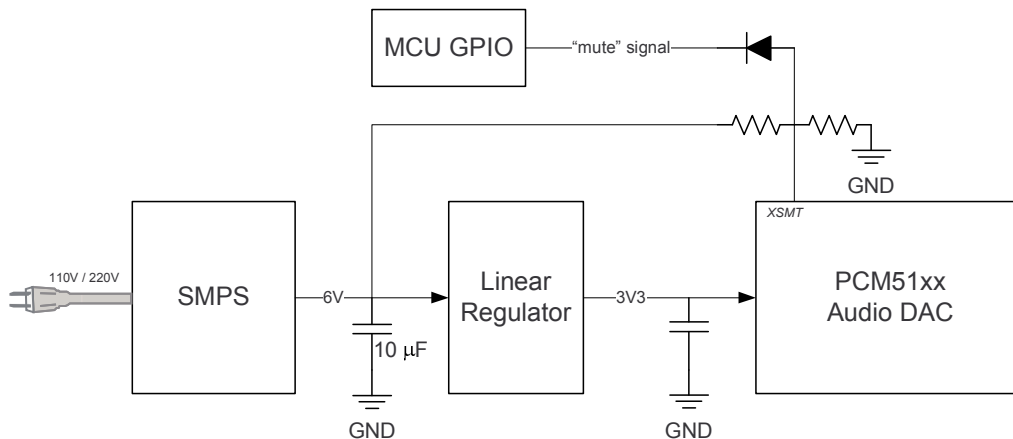

Figure 37. Using the XSMT Pin

Typical Application Circuits

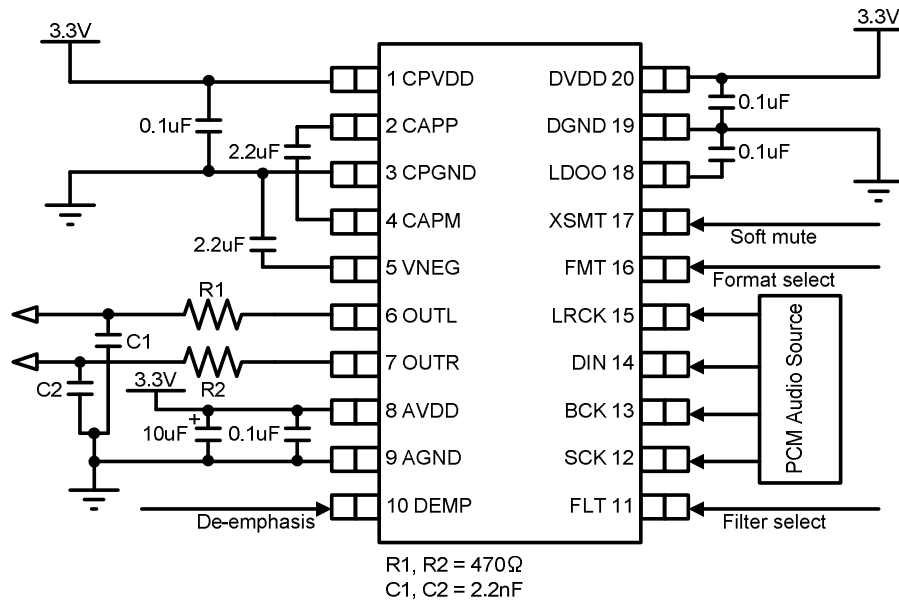

Figure 38. PCM510x Standard PCM Audio Operation, 3.3V

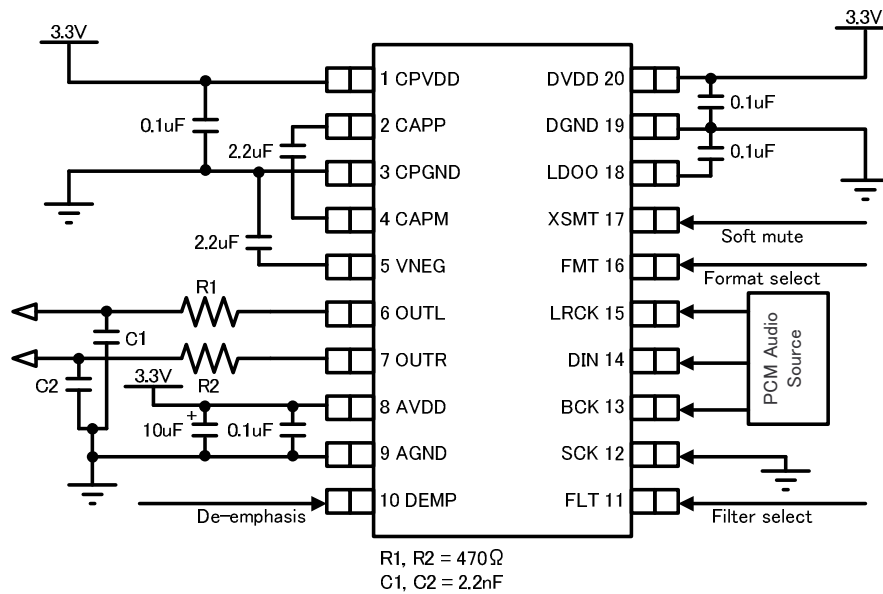
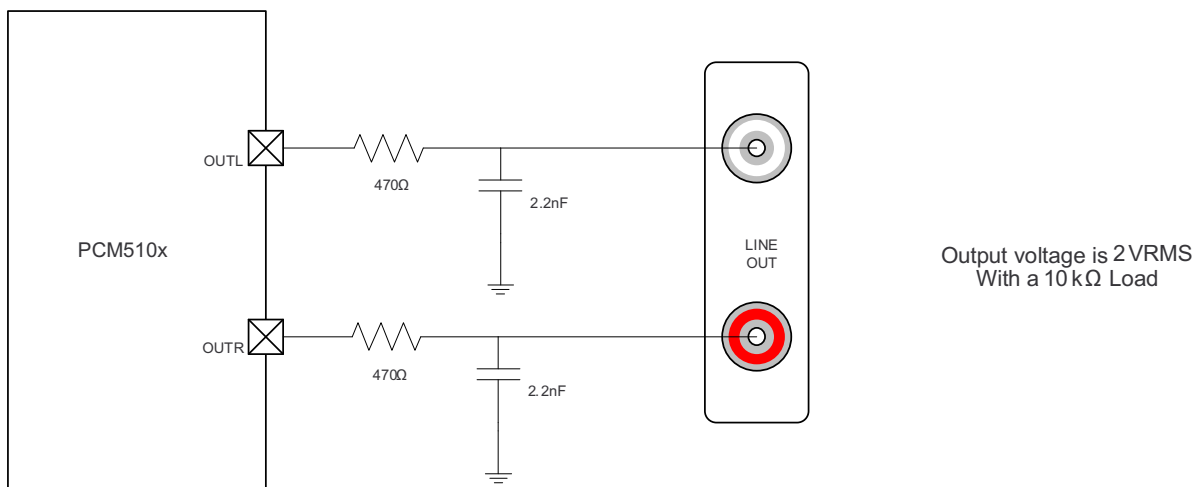

Figure 39. PCM510x PLL Operation, 3.3V

**Recommended Output Filter for the PCM510x**

The diagram in [Figure 40](#) shows the recommended output filter for the PCM510x. The new PCM510x next generation current segment architecture offers excellent out of band noise, making a traditional 20kHz low pass filter a thing of the past.

The RC settings below offer a  $-3\text{dB}$  filter point at 153kHz (approx), giving the DAC the ability to reproduce virtually all frequencies through to it's maximum sampling rate of 384kHz.



**Figure 40. Recommended Output Lowpass Filter for 10kΩ Operation**

**REVISION HISTORY**

<b>Changes from Revision Initial Release (May 2011) to Revision A</b>	<b>Page</b>
• Changed layout of first two pages .....	1
• Deleted "Device Power Dissipation" row .....	4
• Changed "VOOUT = -1 dB" to " -1 dBFS" in THD+N .....	5
• Changed reference to correct footnote .....	6
• Changed Updated plot .....	7
• Changed $t_{SCKH}$ and $t_{SCKL}$ values to 9ns. ....	11
• Removed 48kHz sample rate with PLL-generated clock .....	12
• Added BCK frequency max for convenience .....	13
• Added PCM510x application diagram, PLL Operation .....	26

**REVISION HISTORY**

<b>Changes from Revision A (March 2012) to Revision B</b>	<b>Page</b>
• fixed typos associated with the term "sample frequency" .....	1

**PACKAGING INFORMATION**

Orderable Device	Status (1)	Package Type	Package Drawing	Pins	Package Qty	Eco Plan (2)	Lead/Ball Finish	MSL Peak Temp (3)	Op Temp (°C)	Top-Side Markings (4)	Samples
PCM5100PW	NRND	TSSOP	PW	20	70	Green (RoHS & no Sb/Br)	CU NIPDAU	Level-1-260C-UNLIM	-25 to 85	PCM5100	
PCM5100PWR	NRND	TSSOP	PW	20	2000	Green (RoHS & no Sb/Br)	CU NIPDAU	Level-1-260C-UNLIM	-25 to 85	PCM5100	
PCM5101PW	NRND	TSSOP	PW	20	70	Green (RoHS & no Sb/Br)	CU NIPDAU	Level-1-260C-UNLIM	-25 to 85	PCM5101	
PCM5101PWR	NRND	TSSOP	PW	20	2000	Green (RoHS & no Sb/Br)	CU NIPDAU	Level-1-260C-UNLIM	-25 to 85	PCM5101	
PCM5102PW	NRND	TSSOP	PW	20	70	Green (RoHS & no Sb/Br)	CU NIPDAU	Level-1-260C-UNLIM	-25 to 85	PCM5102	
PCM5102PWR	NRND	TSSOP	PW	20	2000	Green (RoHS & no Sb/Br)	CU NIPDAU	Level-1-260C-UNLIM	-25 to 85	PCM5102	

(1) The marketing status values are defined as follows:

**ACTIVE:** Product device recommended for new designs.

**LIFEBUY:** TI has announced that the device will be discontinued, and a lifetime-buy period is in effect.

**NRND:** Not recommended for new designs. Device is in production to support existing customers, but TI does not recommend using this part in a new design.

**PREVIEW:** Device has been announced but is not in production. Samples may or may not be available.

**OBSELETE:** TI has discontinued the production of the device.

(2) Eco Plan - The planned eco-friendly classification: Pb-Free (RoHS), Pb-Free (RoHS Exempt), or Green (RoHS & no Sb/Br) - please check <http://www.ti.com/productcontent> for the latest availability information and additional product content details.

**TBD:** The Pb-Free/Green conversion plan has not been defined.

**Pb-Free (RoHS):** TI's terms "Lead-Free" or "Pb-Free" mean semiconductor products that are compatible with the current RoHS requirements for all 6 substances, including the requirement that lead not exceed 0.1% by weight in homogeneous materials. Where designed to be soldered at high temperatures, TI Pb-Free products are suitable for use in specified lead-free processes.

**Pb-Free (RoHS Exempt):** This component has a RoHS exemption for either 1) lead-based flip-chip solder bumps used between the die and package, or 2) lead-based die adhesive used between the die and leadframe. The component is otherwise considered Pb-Free (RoHS compatible) as defined above.

**Green (RoHS & no Sb/Br):** TI defines "Green" to mean Pb-Free (RoHS compatible), and free of Bromine (Br) and Antimony (Sb) based flame retardants (Br or Sb do not exceed 0.1% by weight in homogeneous material)

(3) MSL, Peak Temp. -- The Moisture Sensitivity Level rating according to the JEDEC industry standard classifications, and peak solder temperature.

(4) Multiple Top-Side Markings will be inside parentheses. Only one Top-Side Marking contained in parentheses and separated by a "~" will appear on a device. If a line is indented then it is a continuation of the previous line and the two combined represent the entire Top-Side Marking for that device.

**Important Information and Disclaimer:** The information provided on this page represents TI's knowledge and belief as of the date that it is provided. TI bases its knowledge and belief on information provided by third parties, and makes no representation or warranty as to the accuracy of such information. Efforts are underway to better integrate information from third parties. TI has taken and continues to take reasonable steps to provide representative and accurate information but may not have conducted destructive testing or chemical analysis on incoming materials and chemicals. TI and TI suppliers consider certain information to be proprietary, and thus CAS numbers and other limited information may not be available for release.

In no event shall TI's liability arising out of such information exceed the total purchase price of the TI part(s) at issue in this document sold by TI to Customer on an annual basis.

**OTHER QUALIFIED VERSIONS OF PCM5102 :**

- Automotive: [PCM5102-Q1](#)

NOTE: Qualified Version Definitions:

- Automotive - Q100 devices qualified for high-reliability automotive applications targeting zero defects

## TAPE AND REEL INFORMATION



### QUADRANT ASSIGNMENTS FOR PIN 1 ORIENTATION IN TAPE



\*All dimensions are nominal

Device	Package Type	Package Drawing	Pins	SPQ	Reel Diameter (mm)	Reel Width W1 (mm)	A0 (mm)	B0 (mm)	K0 (mm)	P1 (mm)	W (mm)	Pin1 Quadrant
PCM5100PWR	TSSOP	PW	20	2000	330.0	16.4	6.95	7.1	1.6	8.0	16.0	Q1
PCM5101PWR	TSSOP	PW	20	2000	330.0	16.4	6.95	7.1	1.6	8.0	16.0	Q1
PCM5102PWR	TSSOP	PW	20	2000	330.0	16.4	6.95	7.1	1.6	8.0	16.0	Q1

## TAPE AND REEL BOX DIMENSIONS



\*All dimensions are nominal

Device	Package Type	Package Drawing	Pins	SPQ	Length (mm)	Width (mm)	Height (mm)
PCM5100PWR	TSSOP	PW	20	2000	350.0	350.0	43.0
PCM5101PWR	TSSOP	PW	20	2000	350.0	350.0	43.0
PCM5102PWR	TSSOP	PW	20	2000	350.0	350.0	43.0



PW (R-PDSO-G20)

PLASTIC SMALL OUTLINE

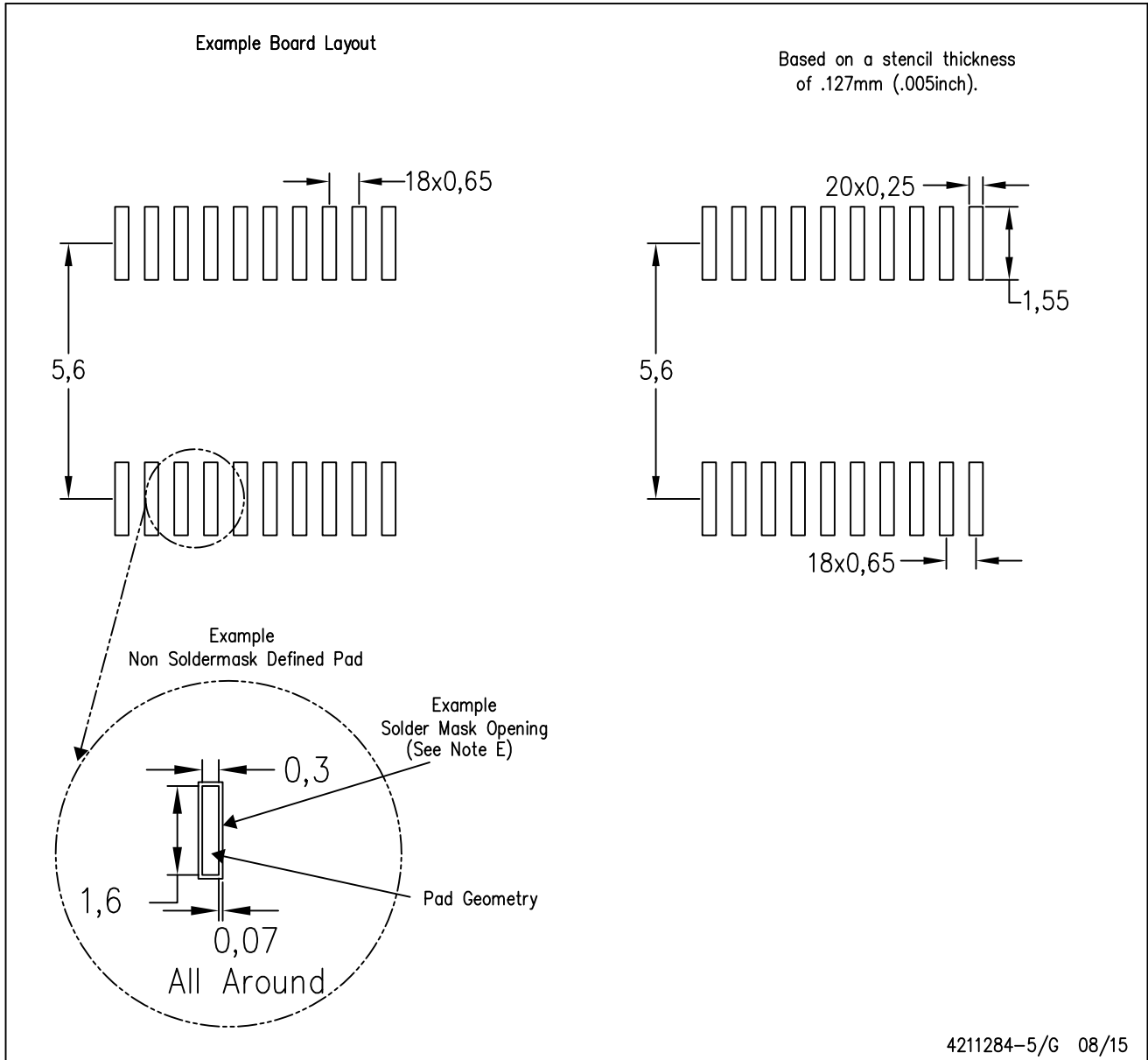

- NOTES:
- A. All linear dimensions are in millimeters.
  - B. This drawing is subject to change without notice.
  - C. Publication IPC-7351 is recommended for alternate design.
  - D. Laser cutting apertures with trapezoidal walls and also rounding corners will offer better paste release. Customers should contact their board assembly site for stencil design recommendations. Refer to IPC-7525 for other stencil recommendations.
  - E. Customers should contact their board fabrication site for solder mask tolerances between and around signal pads.

## IMPORTANT NOTICE AND DISCLAIMER

TI PROVIDES TECHNICAL AND RELIABILITY DATA (INCLUDING DATASHEETS), DESIGN RESOURCES (INCLUDING REFERENCE DESIGNS), APPLICATION OR OTHER DESIGN ADVICE, WEB TOOLS, SAFETY INFORMATION, AND OTHER RESOURCES "AS IS" AND WITH ALL FAULTS, AND DISCLAIMS ALL WARRANTIES, EXPRESS AND IMPLIED, INCLUDING WITHOUT LIMITATION ANY IMPLIED WARRANTIES OF MERCHANTABILITY, FITNESS FOR A PARTICULAR PURPOSE OR NON-INFRINGEMENT OF THIRD PARTY INTELLECTUAL PROPERTY RIGHTS.

These resources are intended for skilled developers designing with TI products. You are solely responsible for (1) selecting the appropriate TI products for your application, (2) designing, validating and testing your application, and (3) ensuring your application meets applicable standards, and any other safety, security, or other requirements. These resources are subject to change without notice. TI grants you permission to use these resources only for development of an application that uses the TI products described in the resource. Other reproduction and display of these resources is prohibited. No license is granted to any other TI intellectual property right or to any third party intellectual property right. TI disclaims responsibility for, and you will fully indemnify TI and its representatives against, any claims, damages, costs, losses, and liabilities arising out of your use of these resources.

TI's products are provided subject to TI's Terms of Sale ([www.ti.com/legal/termsofsale.html](http://www.ti.com/legal/termsofsale.html)) or other applicable terms available either on [ti.com](http://ti.com) or provided in conjunction with such TI products. TI's provision of these resources does not expand or otherwise alter TI's applicable warranties or warranty disclaimers for TI products.

Mailing Address: Texas Instruments, Post Office Box 655303, Dallas, Texas 75265  
Copyright © 2019, Texas Instruments Incorporated

## Looking for pricing, stock, or lifecycle information?

Click below to explore more details on WIN SOURCE:

 [View PCM5102PWR](#) on WIN SOURCE

 [Texas Instruments](#) Information

## Optimize Your Supply Chain with WIN SOURCE Solutions

-  Global Sourcing Solution
-  Obsolete Management
-  Cost Control Management
-  Shortage Management
-  Alternative Solution
-  Excess Inventory Management