



**THE DATASHEET OF
HDC1080DMBT**



HDC1080 Low Power, High Accuracy Digital Humidity Sensor with Temperature Sensor

1 Features

- Relative Humidity Accuracy $\pm 2\%$ (typical)
- Temperature Accuracy $\pm 0.2^\circ\text{C}$ (typical)
- Excellent Stability at High Humidity
- 14 Bit Measurement Resolution
- 100 nA Sleep Mode Current
- Average Supply Current:
 - 710 nA @ 1sps, 11 bit RH Measurement
 - 1.3 μA @ 1sps, 11 bit RH and Temperature Measurement
- Supply Voltage 2.7 V to 5.5 V
- Small 3 mm x 3 mm Device Footprint
- I²C Interface

2 Applications

- HVAC
- Smart Thermostats and Room Monitors
- White Goods
- Printers
- Handheld Meters
- Medical Devices
- Wireless Sensor (TIDA: [00374](#), [00484](#), [00524](#))

4 Typical Application

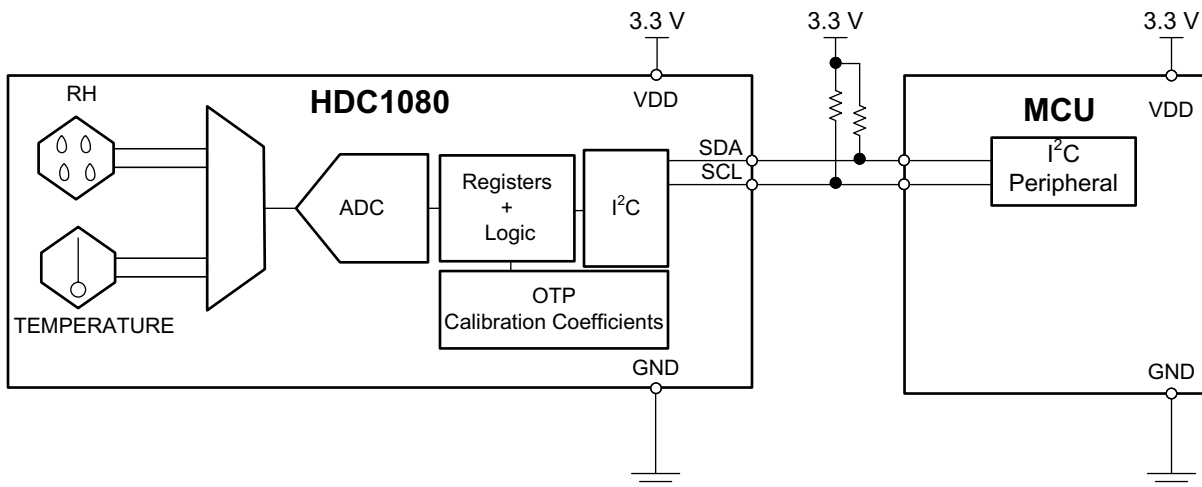

3 Description

The HDC1080 is a digital humidity sensor with integrated temperature sensor that provides excellent measurement accuracy at very low power. The HDC1080 operates over a wide supply range, and is a low cost, low power alternative to competitive solutions in a wide range of common applications. The humidity and temperature sensors are factory calibrated.

Device Information ⁽¹⁾

PART NUMBER	PACKAGE	BODY SIZE (NOM)
HDC1080	PWSON (6-pin) DMB	3.00 mm x 3.00 mm

(1) For all available packages, see the orderable addendum at the end of the datasheet.



Table of Contents

1 Features	1	8.4 Device Functional Modes.....	9
2 Applications	1	8.5 Programming.....	10
3 Description	1	8.6 Register Map	14
4 Typical Application	1	9 Application and Implementation	17
5 Revision History	2	9.1 Application Information.....	17
6 Pin Configuration and Functions	3	9.2 Typical Application	17
7 Specifications	4	9.3 Implementation and Usage Recommendations	18
7.1 Absolute Maximum Ratings	4	10 Power Supply Recommendations	19
7.2 ESD Ratings.....	4	11 Layout	19
7.3 Recommended Operating Conditions.....	4	11.1 Layout Guidelines	19
7.4 Thermal Information	4	11.2 Layout Example	19
7.5 Electrical Characteristics.....	5	12 Device and Documentation Support	21
7.6 I2C Interface Electrical Characteristics	6	12.1 Documentation Support	21
7.7 I2C Interface Timing Requirements	6	12.2 Community Resources.....	21
7.8 Typical Characteristics.....	7	12.3 Trademarks	21
8 Detailed Description	9	12.4 Electrostatic Discharge Caution.....	21
8.1 Overview	9	12.5 Glossary	21
8.2 Functional Block Diagram	9	13 Mechanical, Packaging, and Orderable Information	21
8.3 Feature Description.....	9		

5 Revision History

Changes from Original (November 2015) to Revision A	Page
• Product Preview to Production Data Release	1

6 Pin Configuration and Functions

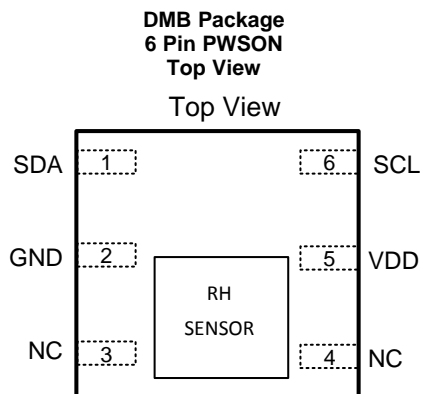

Pin Functions

PIN		I/O TYPE ⁽¹⁾	DESCRIPTION
NAME	NO.		
SDA	1	I/O	Serial data line for I2C, open-drain; requires a pull-up resistor to VDD
GND	2	G	Ground
NC	3,4	-	These pins may be left floating, or connected to GND
VDD	5	P	Supply Voltage
SCL	6	I	Serial clock line for I2C, open-drain; requires a pull-up resistor to VDD
DAP	DAP	-	Die Attach Pad. Should be left floating. (On bottom of the device, not shown in the figure)

(1) P=Power, G=Ground, I=Input, O=Output

7 Specifications

7.1 Absolute Maximum Ratings⁽¹⁾

		MIN	MAX	UNIT
Input Voltage	VDD	-0.3	6	V
	SCL	-0.3	6	
	SDA	-0.3	6	
Storage Temperature	T _{STG}	-65	150	°C

(1) Stresses beyond those listed under *Absolute Maximum Ratings* may cause permanent damage to the device. These are stress ratings only, which do not imply functional operation of the device at these or any other conditions beyond those indicated under *Recommended Operating Conditions*. Exposure to absolute-maximum-rated conditions for extended periods may affect device reliability.

7.2 ESD Ratings

		VALUE	UNIT
V _(ESD) Electrostatic discharge	Human-body model (HBM), per ANSI/ESDA/JEDEC JS-001 ⁽¹⁾	±2000	V
	Charged-device model (CDM), per JEDEC specification JESD22-C101 ⁽²⁾	±500	

(1) JEDEC document JEP155 states that 500-V HBM allows safe manufacturing with a standard ESD control process.

(2) JEDEC document JEP157 states that 250-V CDM allows safe manufacturing with a standard ESD control process.

7.3 Recommended Operating Conditions

over operating range (unless otherwise noted)

		MIN	NOM	MAX	UNIT
V _{DD}	Supply Voltage	2.7	3	5.5	V
T _A , Temperature sensor	Ambient Operating Temperature	-40		125	°C
T _A , Humidity sensor ⁽¹⁾	Ambient Operating Temperature	-20		70	°C
T _A , Humidity sensor ⁽¹⁾	Functional Operating Temperature	-20		85	°C

(1) See [Figure 2](#).

7.4 Thermal Information

THERMAL METRIC ⁽¹⁾		HDC1080	UNIT
		PWSON (DMB)	
		6 PINS	
R _{θJA}	Junction-to-ambient thermal resistance	49.4	°C/W
R _{θJC(top)}	Junction-to-case (top) thermal resistance	29.8	°C/W
R _{θJB}	Junction-to-board thermal resistance	23.1	°C/W
ψ _{JT}	Junction-to-top characterization parameter	3.3	°C/W
ψ _{JB}	Junction-to-board characterization parameter	23.1	°C/W
R _{θJC(bot)}	Junction-to-case (bottom) thermal resistance	4.2	°C/W

(1) For more information about traditional and new thermal metrics, see the *Semiconductor and IC Package Thermal Metrics* application report, [SPRA953](#).

7.5 Electrical Characteristics⁽¹⁾

The electrical ratings specified in this section apply to all specifications in this document, unless otherwise noted. $T_A = 30^\circ\text{C}$, $\text{RH} = 40\%$, and $V_{\text{DD}} = 3\text{V}$.

PARAMETER	TEST CONDITION ⁽²⁾	MIN ⁽³⁾	TYP ⁽⁴⁾	MAX ⁽³⁾	UNIT
POWER CONSUMPTION					
I_{DD} Supply Current	RH measurement, bit 12 of 0x02 register = 0 ⁽⁵⁾		190	220	μA
	Temperature measurement, bit 12 of 0x02 register = 0 ⁽⁵⁾		160	185	μA
	Sleep Mode		100	200	nA
	Average @ 1 measurement/second, RH (11 bit), bit 12 of 0x02 register = 0 ⁽⁵⁾⁽⁶⁾		710		nA
	Average @ 1 measurement/second, Temp (11 bit), bit 12 of 0x02 register = 0 ⁽⁵⁾⁽⁶⁾		590		nA
	Average @ 1 measurement/second, RH (11bit) +temperature (11 bit), bit 12 of 0x02 register = 1 ⁽⁵⁾⁽⁶⁾		1.3		μA
	Startup (average on Start-up time)		300		μA
I_{HEAT} Heater Current ⁽⁷⁾	Peak current		7.2		mA
	Average @ 1 measurement/second, RH (11bit) +temperature (11 bit), bit 12 of 0x02 register = 1 ⁽⁵⁾⁽⁶⁾		50		μA
RELATIVE HUMIDITY SENSOR					
RH_{ACC} Accuracy	Refer to Figure 2 in Typical Characteristics section.		± 2		%RH
RH_{REP} Repeatability ⁽⁷⁾	14 bit resolution		± 0.1		%RH
RH_{HYS} Hysteresis ⁽⁸⁾	$10\% \leq \text{RH} \leq 70\%$		± 1		%RH
RH_{RT} Response Time ⁽⁹⁾	$t_{63\%}$ ⁽¹⁰⁾		15		s
RH_{CT} Conversion Time ⁽⁷⁾	8 bit resolution		2.50		ms
	11 bit resolution		3.85		ms
	14 bit resolution		6.50		ms
RH_{OR} Operating Range ⁽¹¹⁾	Non-condensing	0		100	%RH
RH_{LTD} Long Term Drift ⁽¹²⁾			± 0.25		%RH/yr
TEMPERATURE SENSOR					
TEMP_{ACC} Accuracy ⁽⁷⁾	$5^\circ\text{C} < T_A < 60^\circ\text{C}$		± 0.2	± 0.4	$^\circ\text{C}$
TEMP_{REP} Repeatability ⁽⁷⁾	14 bit resolution		± 0.1		$^\circ\text{C}$
TEMP_{CT} Conversion Time ⁽⁷⁾	11 bit accuracy		3.65		ms
	14 bit accuracy		6.35		ms

- (1) Electrical Characteristics Table values apply only for factory testing conditions at the temperature indicated. Factory testing conditions result in very limited self-heating of the device such that $T_J = T_A$. No guarantee of parametric performance is indicated in the electrical tables under conditions of internal self-heating where $T_J > T_A$. Absolute Maximum Ratings indicate junction temperature limits beyond which the device may be permanently degraded, either mechanically or electrically.
- (2) Register values are represented as either binary (b is the prefix to the digits), or hexadecimal (0x is the prefix to the digits). Decimal values have no prefix.
- (3) Limits are ensured by testing, design, or statistical analysis at 30°C . Limits over the operating temperature range are ensured through correlations using statistical quality control (SQC) method.
- (4) Typical values represent the most likely parametric norm as determined at the time of characterization. Actual typical values may vary over time and will also depend on the application and configuration. The typical values are not tested and are not guaranteed on shipped production material.
- (5) $I^2\text{C}$ read/write communication and pull-up resistors current through SCL and SDA not included.
- (6) Average current consumption while conversion is in progress.
- (7) This parameter is specified by design and/or characterization and it is not tested in production.
- (8) The hysteresis value is the difference between an RH measurement in a rising and falling RH environment, at a specific RH point.
- (9) Actual response times will vary dependent on system thermal mass and air-flow.
- (10) Time for the RH output to change by 63% of the total RH change after a step change in environmental humidity.
- (11) Recommended humidity operating range is 10% to 70% RH. Prolonged operation outside this range may result in a measurement offset. The measurement offset will decrease after operating the sensor in this recommended operating range.
- (12) Drift due to aging effects at typical conditions (30°C and 20% to 50% RH). This value may be impacted by dust, vaporized solvents, out-gassing tapes, adhesives, packaging materials, etc.

7.6 I2C Interface Electrical Characteristics

At $T_A=30^{\circ}\text{C}$, $V_{DD}=3\text{V}$ (unless otherwise noted)

PARAMETER	TEST CONDITION	MIN	TYP	MAX	UNIT
I2C INTERFACE VOLTAGE LEVEL					
V_{IH}	Input High Voltage	$0.7 \times V_{DD}$			V
V_{IL}	Input Low Voltage			$0.3 \times V_{DD}$	V
V_{OL}	Output Low Voltage	Sink current 3mA		0.4	V
HYS	Hysteresis ⁽¹⁾	$0.1 \times V_{DD}$			V
C_{IN}	Input Capacitance on all digital pins		0.5		pF

(1) This parameter is specified by design and/or characterization and it is not tested in production.

7.7 I2C Interface Timing Requirements

PARAMETER	TEST CONDITION	MIN	NOM	MAX	UNIT
I2C INTERFACE VOLTAGE LEVEL					
f_{SCL}	Clock Frequency	10		400	kHz
t_{LOW}	Clock Low Time	1.3			μs
t_{HIGH}	Clock High Time	0.6			μs
t_{SP}	Pulse width of spikes that must be suppressed by the input filter ⁽¹⁾			50	ns
t_{START}	Device Start-up time	From $V_{DD} \geq 2.7\text{V}$ to ready for a conversion ⁽¹⁾⁽²⁾	10	15	ms

(1) This parameter is specified by design and/or characterization and it is not tested in production.

(2) Within this interval it is not possible to communicate to the device.

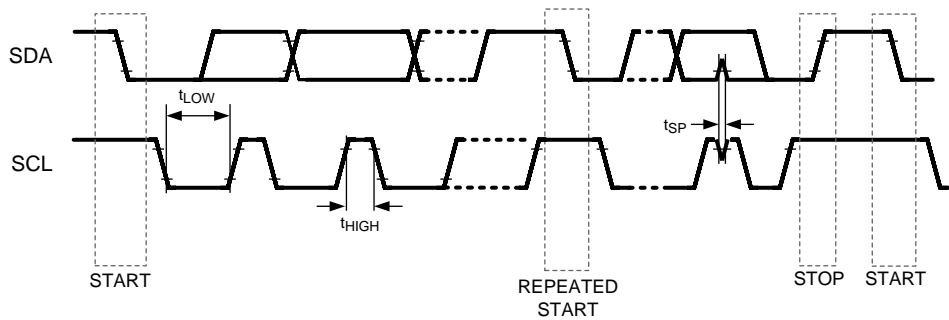

Figure 1. I2C Timing

7.8 Typical Characteristics

Unless otherwise noted. $T_A = 30^\circ\text{C}$, $V_{DD} = 3\text{V}$.

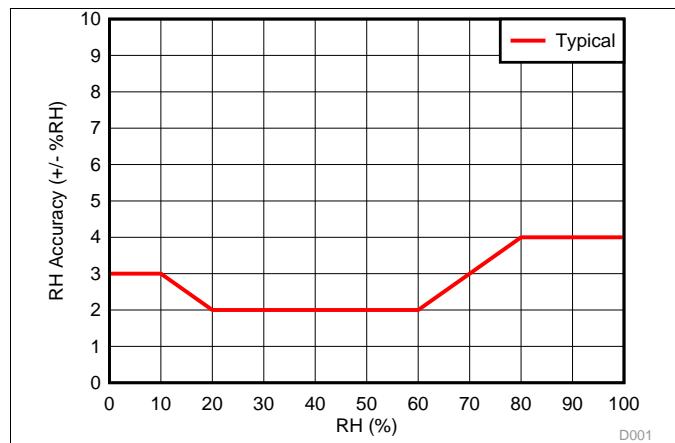

Figure 2. RH Accuracy vs. RH

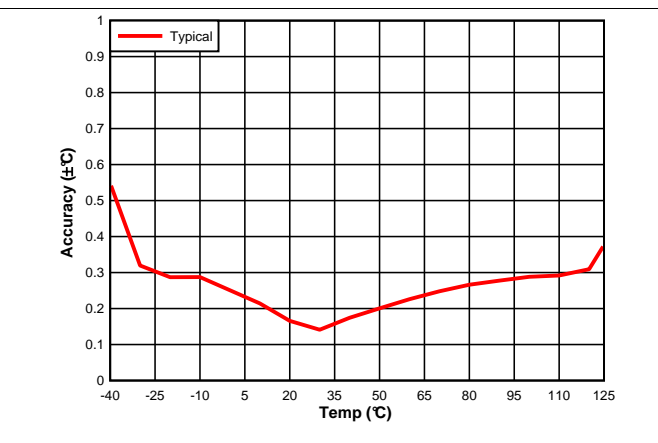

Figure 3. Temperature Accuracy vs. Temperature

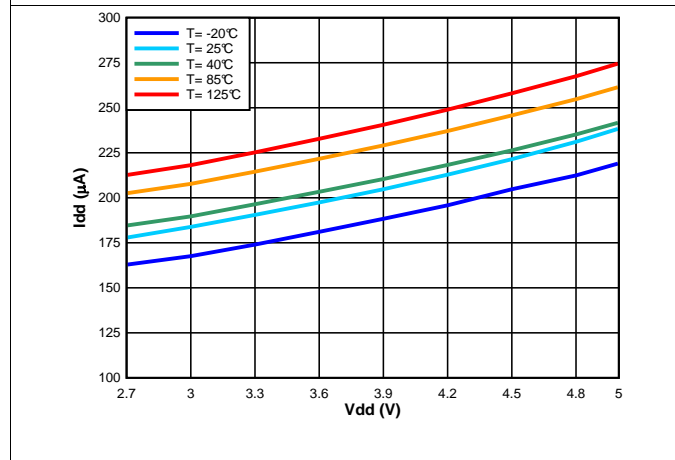

Figure 4. Supply Current vs. Supply Voltage, RH Measurement Active

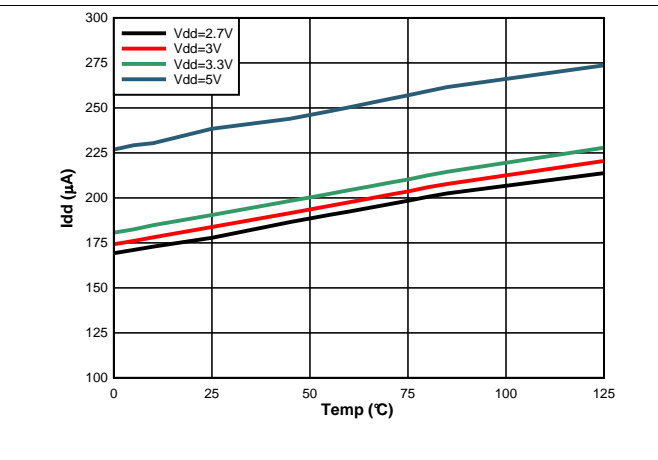

Figure 5. Supply Current vs. Temperature, RH Measurement Active

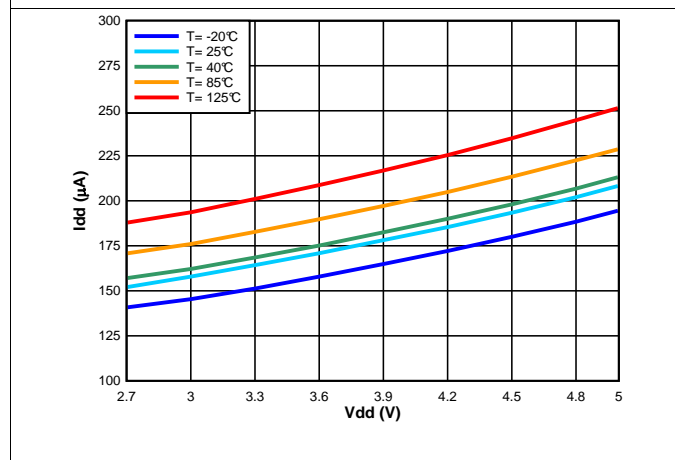

Figure 6. Supply Current vs. Supply Voltage, Temp Measurement Active

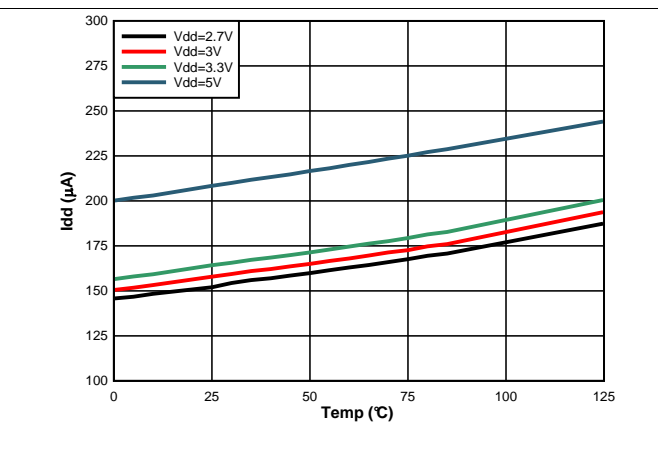
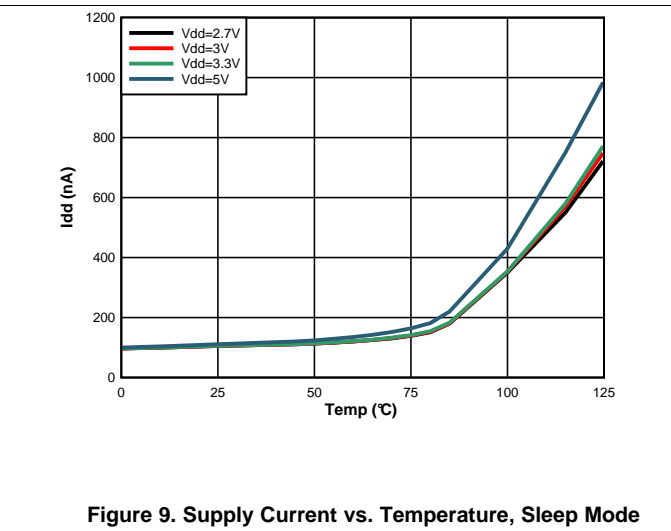
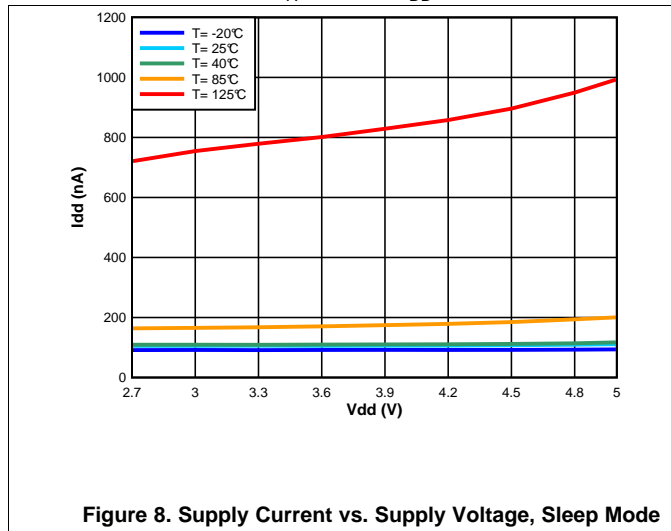

Figure 7. Supply Current vs. Temperature, Temp Measurement Active

Typical Characteristics (continued)

Unless otherwise noted. $T_A = 30^\circ\text{C}$, $V_{DD} = 3\text{V}$.



8 Detailed Description

8.1 Overview

The HDC1080 is a digital humidity sensor with integrated temperature sensor that provides excellent measurement accuracy at very low power. The sensing element of the HDC1080 is placed on the top part of the device. Measurement results can be read out through the I2C compatible interface. Resolution is based on the measurement time and can be 8, 11, or 14 bits for humidity; 11 or 14 bits for temperature.

8.2 Functional Block Diagram

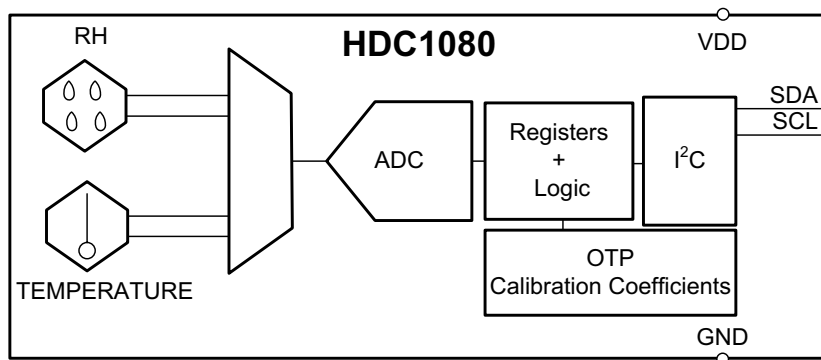

8.3 Feature Description

8.3.1 Power Consumption

One of the key features of the HDC1080 is its low power consumption, which makes the device suitable in battery or power harvesting applications. In these applications the HDC1080 spends most of the time in sleep mode: with a typical 100nA of current consumption in sleep mode, the averaged current consumption is minimal. Its low consumption in measurement mode minimizes any self-heating.

8.3.2 Voltage Supply Monitoring

The HDC1080 monitors the supply voltage level and indicates when the voltage supply of the HDC1080 is less than 2.8V. This information is useful in battery-powered systems in order to inform the user to replace the battery. This is reported in the BTST field (register address 0x02:bit[11]) which is updated after POR and after each measurement request.

8.3.3 Heater

The heater is an integrated resistive element that can be used to test the sensor or to drive condensation off the sensor. The heater can be activated using HEAT, bit 13 in the Configuration Register. The heater helps in reducing the accumulated offset after long exposure at high humidity conditions.

Once enabled the heater is turned on only in the measurement mode. To accelerate the temperature increase it is suggested to increase the measurement data rate.

8.4 Device Functional Modes

The HDC1080 has two modes of operation: sleep mode and measurement mode. After power up, the HDC1080 is in sleep mode. In this mode, the HDC1080 waits for I2C input including commands to configure the conversion times, read the status of the battery, trigger a measurement, and read measurements. Once it receives a command to trigger a measurement, the HDC1080 moves from sleep mode to measurement mode. After completing the measurement the HDC1080 returns to sleep mode.

8.5 Programming

8.5.1 I2C Interface

The HDC1080 operates only as a slave device on the I2C bus interface. It is not allowed to have on the I2C bus multiple devices with the same address. Connection to the bus is made via the open-drain I/O lines, SDA, and SCL. The SDA and SCL pins feature integrated spike-suppression filters and Schmitt triggers to minimize the effects of input spikes and bus noise. After power-up, the sensor needs at most 15 ms, to be ready to start RH and temperature measurement. During this power-up time the HDC1080 is only able to provide the content of the serial number registers (0xFB to 0xFF) if requested. After the power-up the sensor is in the sleep mode until a communication or measurement is performed. All data bytes are transmitted MSB first.

8.5.1.1 Serial Bus Address

To communicate with the HDC1080, the master must first address slave devices via a slave address byte. The slave address byte consists of seven address bits, and a direction bit that indicates the intent to execute a read or write operation. The I2C address of the HDC1080 is 1000000 (7-bit address).

8.5.1.2 Read and Write Operations

To access a particular register on the HDC1080, write the desired register address value to the Pointer Register. The pointer value is the first byte transferred after the slave address byte with the R/W bit low. Every write operation to the HDC1080 requires a value for the pointer register (refer to [Figure 10](#)).

When reading from the HDC1080, the last value stored in the pointer by a write operation is used to determine which register is accessed by a read operation. To change the pointer register for a read operation, a new value must be written to the pointer register. This transaction is accomplished by issuing the slave address byte with the R/W bit low, followed by the pointer byte. No additional data is required (refer to [Figure 11](#)).

The master can then generate a START condition and send the slave address byte with the R/W bit high to initiate the read command. Note that register bytes are sent MSB first, followed by the LSB. A write operation in a read-only register such as (DEVICE ID, MANUFACTURER ID, SERIAL ID) returns a NACK after each data byte; read/write operation to unused address returns a NACK after the pointer; a read/write operation with incorrect I2C address returns a NACK after the I2C address.

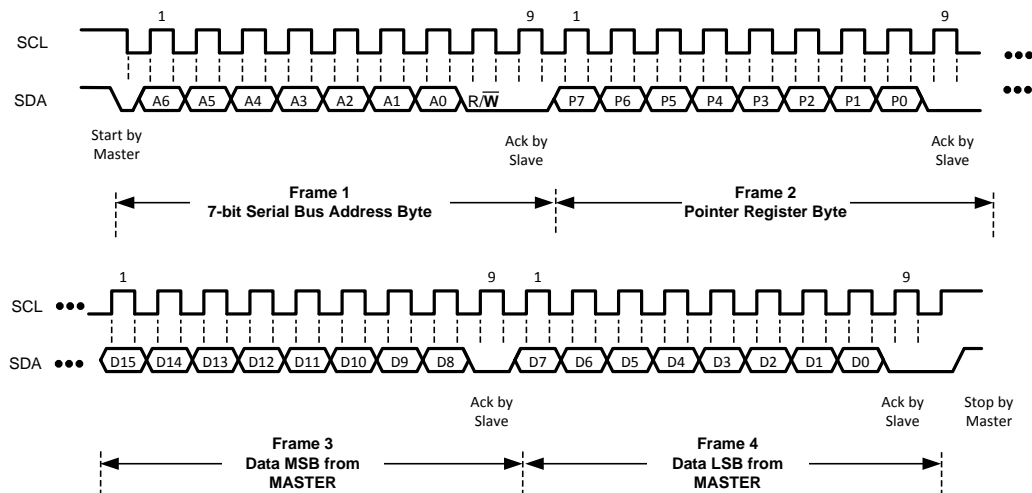

Figure 10. Writing Frame (Configuration Register)

Programming (continued)

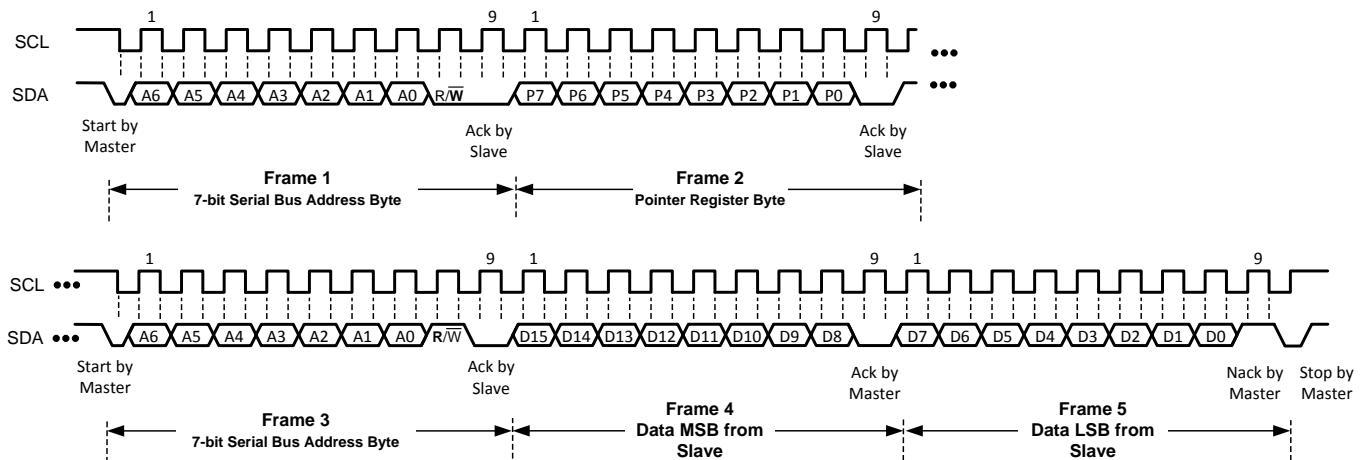

Figure 11. Reading Frame (Configuration Register)

8.5.1.3 Device Measurement Configuration

By default the HDC1080 will first perform a temperature measurement followed by a humidity measurement. On power-up, the HDC1080 enters a low power sleep mode and is not actively measuring. Use the following steps to perform a measurement of both temperature and humidity and then retrieve the results:

1. Configure the acquisition parameters in register address 0x02:
 - (a) Set the acquisition mode to measure both temperature and humidity by setting Bit[12] to 1.
 - (b) Set the desired temperature measurement resolution:
 - Set Bit[10] to 0 for 14 bit resolution.
 - Set Bit[10] to 1 for 11 bit resolution.
 - (c) Set the desired humidity measurement resolution:
 - Set Bit[9:8] to 00 for 14 bit resolution.
 - Set Bit[9:8] to 01 for 11 bit resolution.
 - Set Bit[9:8] to 10 for 8 bit resolution.
2. Trigger the measurements by executing a pointer write transaction with the address pointer set to 0x00. Refer to [Figure 12](#).
3. Wait for the measurements to complete, based on the conversion time (refer to [Electrical Characteristics](#)⁽¹⁾ for the conversion time).
4. Read the output data:

Read the temperature data from register address 0x00, followed by the humidity data from register address 0x01 in a single transaction as shown in [Figure 14](#). A read operation will return a NACK if the contents of the registers have not been updated as shown in [Figure 13](#).

To perform another acquisition with the same measurement configuration simply repeat steps 2 through 4.

If only a humidity or temperature measurement is desired, the following steps will perform a measurement and retrieve the result:

1. Configure the acquisition parameters in register address 0x02:
 - (a) Set the acquisition mode to independently measure temperature or humidity by setting Bit[12] to 0.
 - (b) For a temperature measurement, set the desired temperature measurement resolution:
 - Set Bit[10] to 0 for 14 bit resolution.
 - Set Bit[10] to 1 for 11 bit resolution.

(1) Electrical Characteristics Table values apply only for factory testing conditions at the temperature indicated. Factory testing conditions result in very limited self-heating of the device such that $T_J = T_A$. No guarantee of parametric performance is indicated in the electrical tables under conditions of internal self-heating where $T_J > T_A$. Absolute Maximum Ratings indicate junction temperature limits beyond which the device may be permanently degraded, either mechanically or electrically.

Programming (continued)

- (c) For a humidity measurement, set the desired humidity measurement resolution:
 - Set Bit[9:8] to 00 for 14 bit resolution.
 - Set Bit[9:8] to 01 for 11 bit resolution.
 - Set Bit[9:8] to 10 for 8 bit resolution.
2. Trigger the measurement by executing a pointer write transaction. Refer to [Figure 12](#)
 - Set the address pointer to 0x00 for a temperature measurement.
 - Set the address pointer to 0x01 for a humidity measurement.
3. Wait for the measurement to complete, based on the conversion time (refer to [Electrical Characteristics^{\(1\)}](#) for the conversion time).
4. Read the output data:

Retrieve the completed measurement result from register address 0x00 or 0x01, as appropriate, as shown in [Figure 11](#). A read operation will return a NACK if the measurement result is not yet available, as shown in [Figure 13](#).

To perform another acquisition with the same measurement configuration repeat steps 2 through 4.

It is possible to read the output registers (addresses 0x00 and 0x01) during a Temperature or Relative Humidity measurement without affecting any ongoing measurement. Note that a write to address 0x00 or 0x01 while a measurement is ongoing will abort the ongoing measurement.

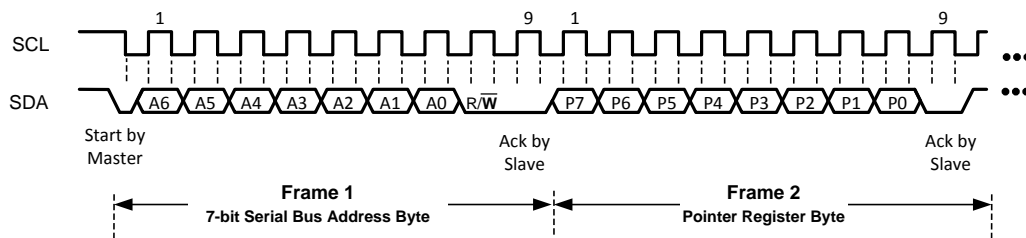

Figure 12. Trigger Humidity/Temperature Measurement

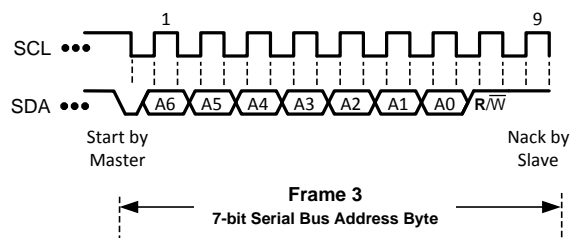

Figure 13. Read Humidity/Temperature Measurement (Data Not Ready)

Programming (continued)

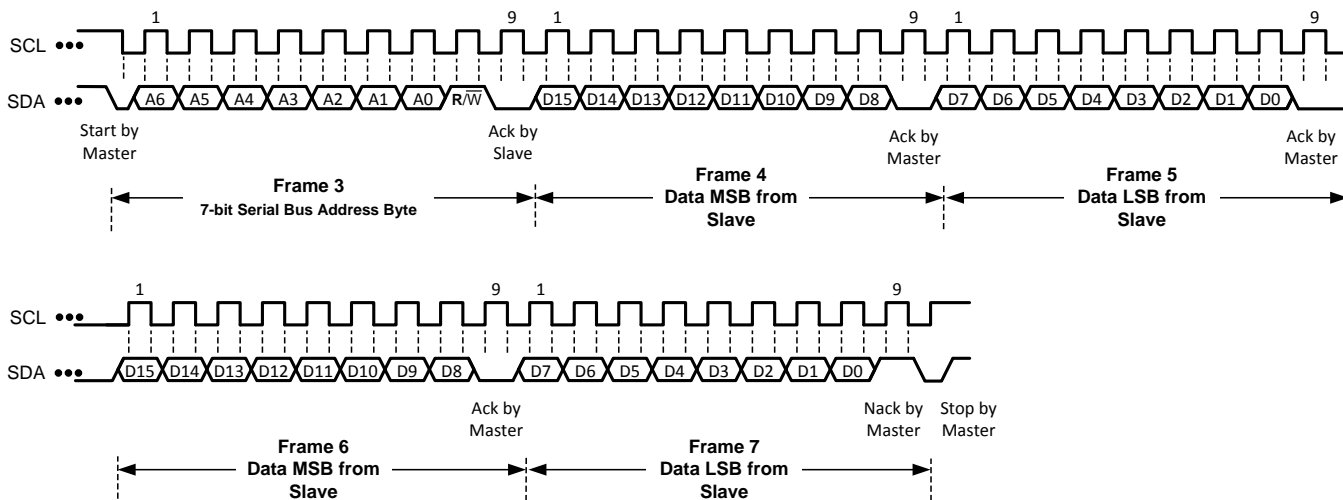

Figure 14. Read Humidity and Temperature Measurement (Data Ready)

8.6 Register Map

The HDC1080 contains data registers that hold configuration information, temperature and humidity measurement results, and status information.

Table 1. Register Map

Pointer	Name	Reset value	Description
0x00	Temperature	0x0000	Temperature measurement output
0x01	Humidity	0x0000	Relative Humidity measurement output
0x02	Configuration	0x1000	HDC1080 configuration and status
0xFB	Serial ID	device dependent	First 2 bytes of the serial ID of the part
0xFC	Serial ID	device dependent	Mid 2 bytes of the serial ID of the part
0xFD	Serial ID	device dependent	Last byte bit of the serial ID of the part
0xFE	Manufacturer ID	0x5449	ID of Texas Instruments
0xFF	Device ID	0x1050	ID of the device

Registers addresses 0x03 to 0xFA are reserved and should not be written.

The HDC1080 has an 8-bit pointer used to address a given data register. The pointer identifies which of the data registers should respond to a read or write command on the two-wire bus. This register is set with every write command. A write command must be issued to set the proper value in the pointer before executing a read command. The power-on reset (POR) value of the pointer is 0x00, which selects a temperature measurement.

8.6.1 Temperature Register

The temperature register is a 16-bit result register in binary format (the 2 LSBs D1 and D0 are always 0). The result of the acquisition is always a 14 bit value. The accuracy of the result is related to the selected conversion time (refer to [Electrical Characteristics^{\(1\)}](#)). The temperature can be calculated from the output data with:

$$\text{Temperature}(^{\circ}\text{C}) = \left(\frac{\text{TEMPERATURE}[15:00]}{2^{16}} \right) * 165^{\circ}\text{C} - 40^{\circ}\text{C}$$

Table 2. Temperature Register Description (0x00)

Name	Bits	Description
TEMPERATURE	[15:02]	Temperature Temperature measurement (read only)
	[01:00]	Reserved Reserved, always 0 (read only)

- (1) Electrical Characteristics Table values apply only for factory testing conditions at the temperature indicated. Factory testing conditions result in very limited self-heating of the device such that $T_J = T_A$. No guarantee of parametric performance is indicated in the electrical tables under conditions of internal self-heating where $T_J > T_A$. Absolute Maximum Ratings indicate junction temperature limits beyond which the device may be permanently degraded, either mechanically or electrically.

8.6.2 Humidity Register

The humidity register is a 16-bit result register in binary format (the 2 LSBs D1 and D0 are always 0). The result of the acquisition is always a 14 bit value, while the accuracy is related to the selected conversion time (refer to [Electrical Characteristics^{\(1\)}](#)). The humidity can be calculated from the output data with:

$$\text{Relative Humidity}(\% \text{ RH}) = \left(\frac{\text{HUMIDITY}[15:00]}{2^{16}} \right) * 100\% \text{ RH}$$

Table 3. Humidity Register Description (0x01)

Name	Bits	Description
HUMIDITY	[15:02]	Relative Humidity Relative Humidity measurement (read only)
	[01:00]	Reserved Reserved, always 0 (read only)

- (1) Electrical Characteristics Table values apply only for factory testing conditions at the temperature indicated. Factory testing conditions result in very limited self-heating of the device such that $T_J = T_A$. No guarantee of parametric performance is indicated in the electrical tables under conditions of internal self-heating where $T_J > T_A$. Absolute Maximum Ratings indicate junction temperature limits beyond which the device may be permanently degraded, either mechanically or electrically.

8.6.3 Configuration Register

This register configures device functionality and returns status.

Table 4. Configuration Register Description (0x02)

NAME	Bits	DESCRIPTION		
RST	[15]	Software reset bit	0	Normal Operation, this bit self clears
			1	Software Reset
Reserved	[14]	Reserved	0	Reserved, must be 0
HEAT	[13]	Heater	0	Heater Disabled
			1	Heater Enabled
MODE	[12]	Mode of acquisition	0	Temperature or Humidity is acquired.
			1	Temperature and Humidity are acquired in sequence, Temperature first.
BTST	[11]	Battery Status	0	Battery voltage > 2.8V (read only)
			1	Battery voltage < 2.8V (read only)
TRES	[10]	Temperature Measurement Resolution	0	14 bit
			1	11 bit
HRES	[9:8]	Humidity Measurement Resolution	00	14 bit
			01	11 bit
			10	8 bit
Reserved	[7:0]	Reserved	0	Reserved, must be 0

8.6.4 Serial Number Registers

These registers contain a 40bit unique serial number for each individual HDC1080.

Table 5. Serial Number Register Description (0xFB)

Name	Bits	Description	
SERIAL ID[40:25]	[15:0]	Serial Id bits	Device Serial Number bits from 40 to 25 (read only)

Table 6. Serial Number Register Description (0xFC)

Name	Bits	Description	
SERIAL ID[24:9]	[15:0]	Serial Id bits	Device Serial Number bits from 24 to 9(read only)

Table 7. Serial Number Register Description (0xFD)

Name	Bits	Description	
SERIAL ID[8:0]	[15:7]	Serial Id bits	Device Serial Number bits from 8 to 0 (read only)
	[6:0]	Reserved	Reserved, always 0 (read only)

8.6.5 Manufacturer ID Register

This register contains a factory-programmable identification value that identifies this device as being manufactured by Texas Instruments. This register distinguishes this device from other devices that are on the same I2C bus. The manufacturer ID reads 0x5449.

Table 8. Manufacturer ID Register Description (0xFE)

Name	Bits	Description		
MANUFACTURER ID	[15:0]	Manufacturer ID	0x5449	Texas instruments ID (read only)

8.6.6 Device Register ID

This register contains a factory-programmable identification value that identifies the device. This register distinguishes this device from other devices that are on the same I2C bus. A reading of the Device ID register returns 0x1050.

Table 9. Device ID Register Description (0xFF)

Name	Bits		Description
DEVICE ID	[15:0]	Device ID	0x1050 Device ID (read only)

9 Application and Implementation

NOTE

Information in the following applications sections is not part of the TI component specification, and TI does not warrant its accuracy or completeness. TI's customers are responsible for determining suitability of components for their purposes. Customers should validate and test their design implementation to confirm system functionality.

9.1 Application Information

An HVAC system thermostat control is based on environmental sensors and a micro-controller. The microcontroller acquires data from humidity sensors and temperature sensors and controls the heating/cooling system. The collected data are then shown on a display that can be easily controlled by the micro controller. Based on data from the humidity and temperature sensor, the heating/cooling system then maintains the environment at customer-defined preferred conditions.

9.2 Typical Application

In a battery-powered HVAC system thermostat, one of the key parameters in the selection of components is the power consumption. The HDC1080, with 1.3µA of current consumption (average consumption over 1s for RH and Temperature measurements), in conjunction with an MSP430, represents an excellent choice for low power consumption, which extends the battery life. A system block diagram of a battery powered thermostat is shown in [Figure 15](#).

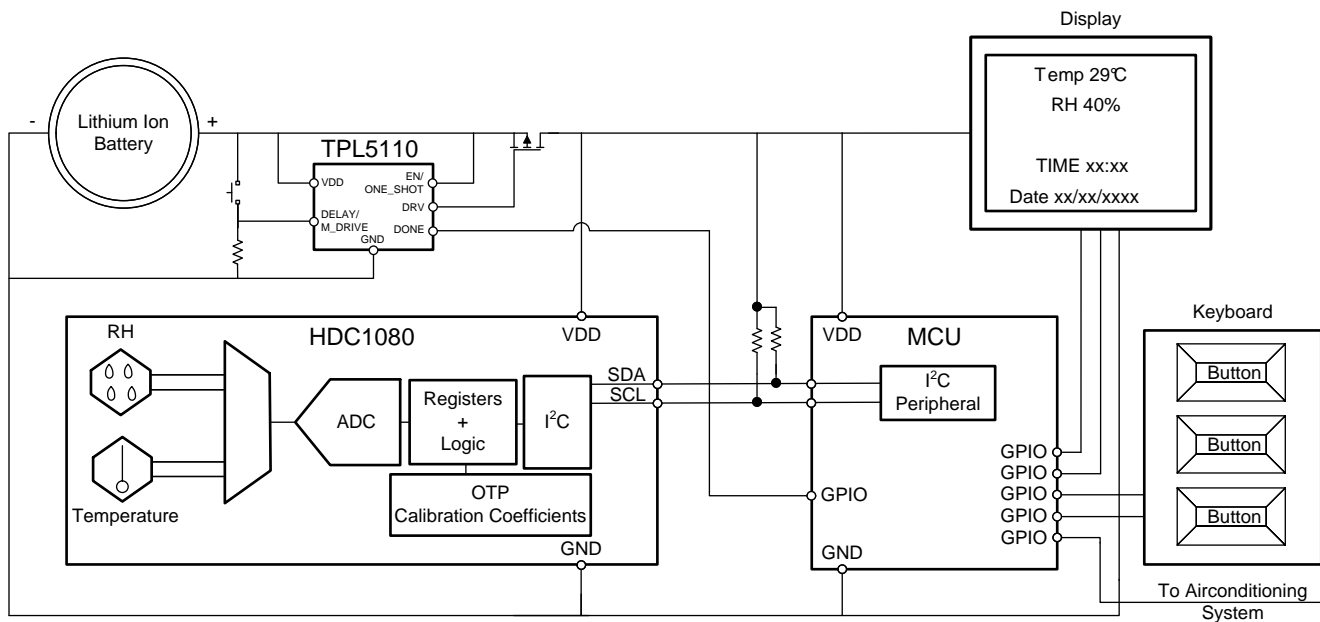

Figure 15. Typical Application Schematic HVAC

9.2.1 Design Requirements

In order to correctly sense the ambient temperature and humidity, the HDC1080 should be positioned away from heat sources on the PCB. Generally, it should not be close to the LCD and battery. Moreover, to minimize any self-heating of the HDC1080 it is recommended to acquire at a maximum sample rate of 1sps (RH + Temp). In home systems, humidity and the temperature monitoring rates of less than 1sps (even 0.5sps or 0.2sps) can be still effective.

Typical Application (continued)

9.2.2 Detailed Design Procedure

When a circuit board layout is created from the schematic shown in [Figure 15](#) a small circuit board is possible. The accuracy of a RH and temperature measurement depends on the sensor accuracy and the setup of the sensing system. The HDC1080 samples relative humidity and temperature in its immediate environment, it is therefore important that the local conditions at the sensor match the monitored environment. Use one or more openings in the physical cover of the thermostat to obtain a good airflow even in static conditions. Refer to the layout below ([Figure 18](#)) for a PCB layout which minimizes the thermal mass of the PCB in the region of the HDC1080, which can improve measurement response time and accuracy.

9.2.3 Application Curve

The data shown below was acquired with the HDC1080EVM. A humidity chamber was used to control the environment.

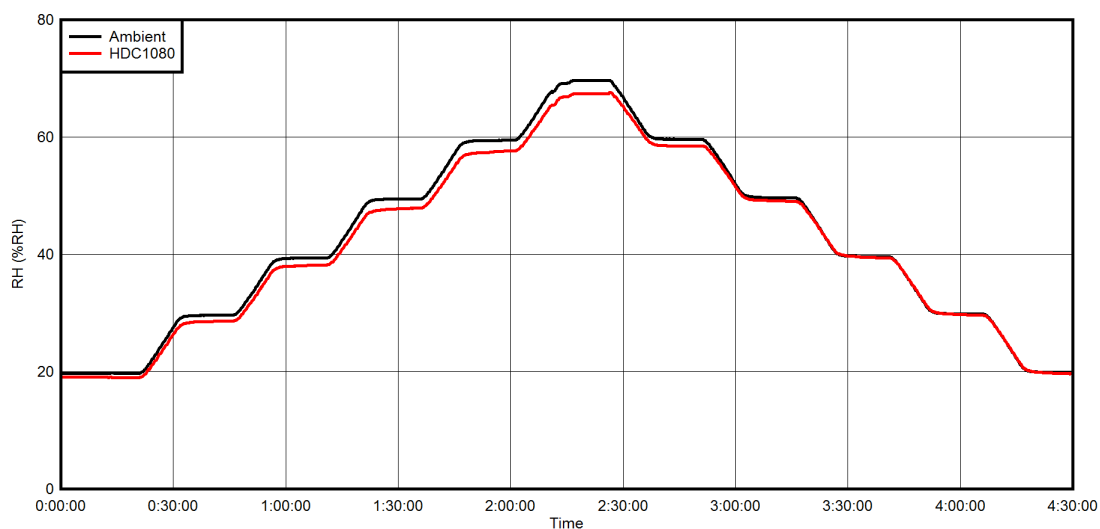

Figure 16. RH vs. Time

9.3 Implementation and Usage Recommendations

9.3.1 Soldering

When soldering the HDC1080 use the standard soldering profile IPC/JEDEC J-STD-020 with peak temperatures of 260 °C.

When soldering the HDC1080 it is mandatory to use no-clean solder paste and no board wash should be applied. The HDC1080 should be limited to a single IR reflow and no rework is recommended.

9.3.2 Chemical Exposure and Sensor Protection

The humidity sensor is not a standard IC and therefore should not be exposed to particulates or volatile chemicals such as solvents or other organic compounds. If any type of protective coating must be applied to the circuit board, the sensor must be protected during the coating process.

9.3.3 High Temperature and Humidity Exposure

Long exposure outside the recommended operating conditions may temporarily offset the RH output. [Table 10](#) shows the RH offset values that can be expected for exposure to 85 °C and 85 % RH for durations between 12 and 500 hours (continuous).

Table 10. Induced RH Offset Due to Extended Exposure to High Humidity and High Temperature (85°C/85% RH)

85°C/85% RH Duration (hours)	12	24	168	500
RH Offset (%)	3	6	12	15

When the sensor is exposed to less severe conditions, [Figure 17](#) shows the typical RH offset at other combinations of temperature and RH.

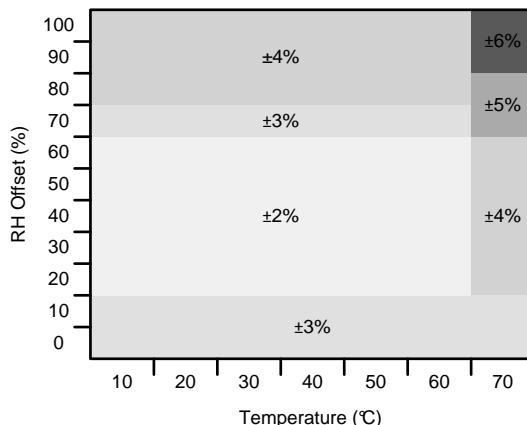

Figure 17. Relative Humidity Accuracy vs Temperature

10 Power Supply Recommendations

The HDC1080 requires a voltage supply within 2.7V and 5.5V. A multilayer ceramic bypass X7R capacitor of 0.1µF between the VDD and GND pins is recommended.

11 Layout

11.1 Layout Guidelines

The Relative Humidity sensor element is located on the top side of the package.

It is recommended to isolate the sensor from the rest of the PCB by eliminating copper layers below the device (GND, V_{DD}) and creating a slot into the PCB around the sensor to enhance thermal isolation.

11.2 Layout Example

The only component next to the device is the supply bypass capacitor. Since the relative humidity is dependent on the temperature, the HDC1080 should be positioned away from hot spots present on the board, such as a battery, display or micro-controller. Slots around the device can be used to reduce the thermal mass, for a quicker response to environmental changes. The DAP may be soldered to a floating pad on the board, but the board pad should NOT be connected to GND.

Layout Example (continued)

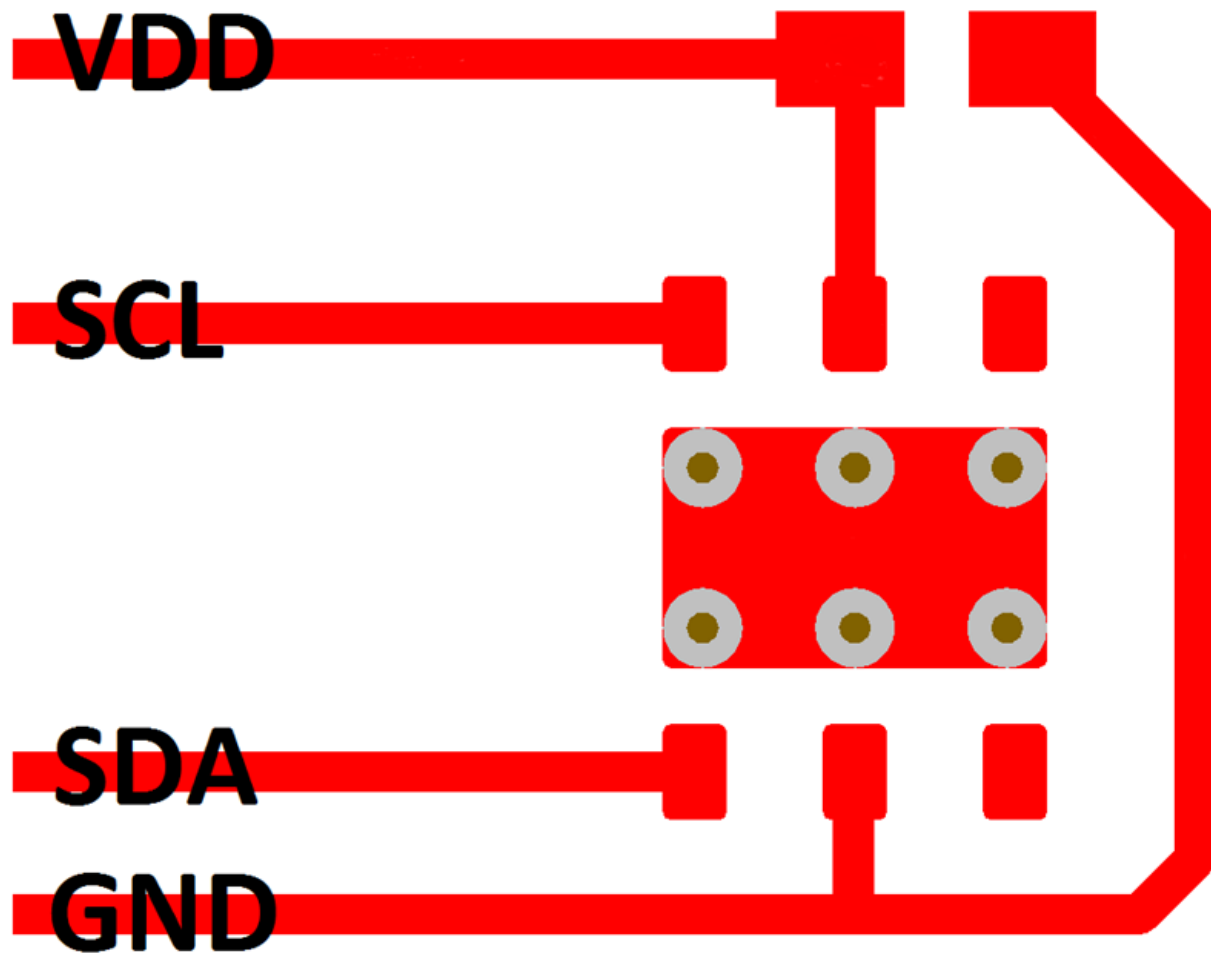

Figure 18. Layout

12 Device and Documentation Support

12.1 Documentation Support

12.1.1 Related Documentation

Texas Instruments Humidity Sensors, [SNAA216](#), provides a general description of humidity sensing and important design guidelines.

Humidity and Temp Sensor Node for Star Networks Enabling 10+ Year Coin Cell Battery Life Ref Design [TIDA-00374](#)

Humidity and Temp Sensor Node for Sub-1GHz Star Networks Enabling 10+ Year Coin Cell Battery Life [TIDA-00484](#)

Ultralow Power Multi-sensor Data Logger with NFC Interface Reference Design [TIDA-00524](#)

12.2 Community Resources

The following links connect to TI community resources. Linked contents are provided "AS IS" by the respective contributors. They do not constitute TI specifications and do not necessarily reflect TI's views; see TI's [Terms of Use](#).

TI E2E™ Online Community *TI's Engineer-to-Engineer (E2E) Community*. Created to foster collaboration among engineers. At [e2e.ti.com](#), you can ask questions, share knowledge, explore ideas and help solve problems with fellow engineers.

Design Support *TI's Design Support* Quickly find helpful E2E forums along with design support tools and contact information for technical support.

12.3 Trademarks

E2E is a trademark of Texas Instruments.
All other trademarks are the property of their respective owners.

12.4 Electrostatic Discharge Caution



These devices have limited built-in ESD protection. The leads should be shorted together or the device placed in conductive foam during storage or handling to prevent electrostatic damage to the MOS gates.

12.5 Glossary

[SLYZ022](#) — *TI Glossary*.

This glossary lists and explains terms, acronyms, and definitions.

13 Mechanical, Packaging, and Orderable Information

The following pages include mechanical, packaging, and orderable information. This information is the most current data available for the designated devices. This data is subject to change without notice and revision of this document. For browser-based versions of this data sheet, refer to the left-hand navigation.

PACKAGING INFORMATION

Orderable Device	Status (1)	Package Type	Package Drawing	Pins	Package Qty	Eco Plan (2)	Lead/Ball Finish (6)	MSL Peak Temp (3)	Op Temp (°C)	Device Marking (4/5)	Samples
HDC1080DMBR	ACTIVE	WSON	DMB	6	3000	Green (RoHS & no Sb/Br)	CU NIPDAU	Level-1-260C-UNLIM	-40 to 125	1R	Samples
HDC1080DMBT	ACTIVE	WSON	DMB	6	250	Green (RoHS & no Sb/Br)	CU NIPDAU	Level-1-260C-UNLIM	-40 to 125	1R	Samples

(1) The marketing status values are defined as follows:

ACTIVE: Product device recommended for new designs.

LIFEBUY: TI has announced that the device will be discontinued, and a lifetime-buy period is in effect.

NRND: Not recommended for new designs. Device is in production to support existing customers, but TI does not recommend using this part in a new design.

PREVIEW: Device has been announced but is not in production. Samples may or may not be available.

OBSOLETE: TI has discontinued the production of the device.

(2) Eco Plan - The planned eco-friendly classification: Pb-Free (RoHS), Pb-Free (RoHS Exempt), or Green (RoHS & no Sb/Br) - please check <http://www.ti.com/productcontent> for the latest availability information and additional product content details.

TBD: The Pb-Free/Green conversion plan has not been defined.

Pb-Free (RoHS): TI's terms "Lead-Free" or "Pb-Free" mean semiconductor products that are compatible with the current RoHS requirements for all 6 substances, including the requirement that lead not exceed 0.1% by weight in homogeneous materials. Where designed to be soldered at high temperatures, TI Pb-Free products are suitable for use in specified lead-free processes.

Pb-Free (RoHS Exempt): This component has a RoHS exemption for either 1) lead-based flip-chip solder bumps used between the die and package, or 2) lead-based die adhesive used between the die and leadframe. The component is otherwise considered Pb-Free (RoHS compatible) as defined above.

Green (RoHS & no Sb/Br): TI defines "Green" to mean Pb-Free (RoHS compatible), and free of Bromine (Br) and Antimony (Sb) based flame retardants (Br or Sb do not exceed 0.1% by weight in homogeneous material)

(3) MSL, Peak Temp. - The Moisture Sensitivity Level rating according to the JEDEC industry standard classifications, and peak solder temperature.

(4) There may be additional marking, which relates to the logo, the lot trace code information, or the environmental category on the device.

(5) Multiple Device Markings will be inside parentheses. Only one Device Marking contained in parentheses and separated by a "~" will appear on a device. If a line is indented then it is a continuation of the previous line and the two combined represent the entire Device Marking for that device.

(6) Lead/Ball Finish - Orderable Devices may have multiple material finish options. Finish options are separated by a vertical ruled line. Lead/Ball Finish values may wrap to two lines if the finish value exceeds the maximum column width.

Important Information and Disclaimer: The information provided on this page represents TI's knowledge and belief as of the date that it is provided. TI bases its knowledge and belief on information provided by third parties, and makes no representation or warranty as to the accuracy of such information. Efforts are underway to better integrate information from third parties. TI has taken and continues to take reasonable steps to provide representative and accurate information but may not have conducted destructive testing or chemical analysis on incoming materials and chemicals. TI and TI suppliers consider certain information to be proprietary, and thus CAS numbers and other limited information may not be available for release.

In no event shall TI's liability arising out of such information exceed the total purchase price of the TI part(s) at issue in this document sold by TI to Customer on an annual basis.

TAPE AND REEL INFORMATION



QUADRANT ASSIGNMENTS FOR PIN 1 ORIENTATION IN TAPE



*All dimensions are nominal

Device	Package Type	Package Drawing	Pins	SPQ	Reel Diameter (mm)	Reel Width W1 (mm)	A0 (mm)	B0 (mm)	K0 (mm)	P1 (mm)	W (mm)	Pin1 Quadrant
HDC1080DMBR	WSON	DMB	6	3000	330.0	15.4	3.3	3.3	1.1	8.0	12.0	Q2
HDC1080DMBT	WSON	DMB	6	250	178.0	12.4	3.3	3.3	1.1	8.0	12.0	Q2

TAPE AND REEL BOX DIMENSIONS

*All dimensions are nominal

Device	Package Type	Package Drawing	Pins	SPQ	Length (mm)	Width (mm)	Height (mm)
HDC1080DMBR	WSON	DMB	6	3000	335.0	335.0	32.0
HDC1080DMBT	WSON	DMB	6	250	336.6	336.6	41.3

DMB 6

GENERIC PACKAGE VIEW
WSO8 - 0.8 mm max height
PLASTIC SMALL OUTLINE - NO LEAD

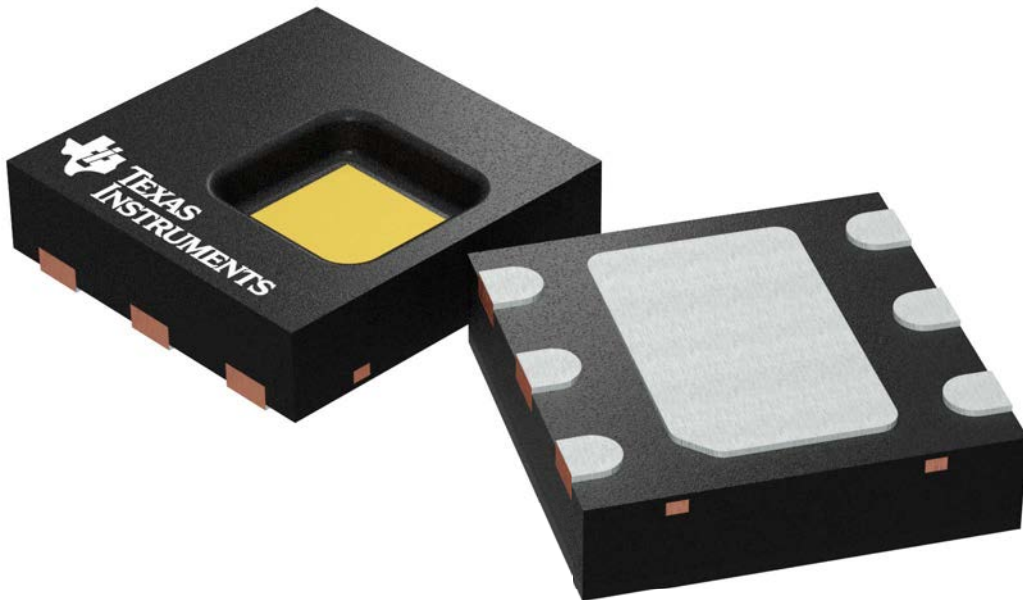

Images above are just a representation of the package family, actual package may vary.
Refer to the product data sheet for package details.

4212623/D

DMB0006A



PACKAGE OUTLINE

WSON - 0.8 mm max height

PLASTIC SMALL OUTLINE - NO LEAD

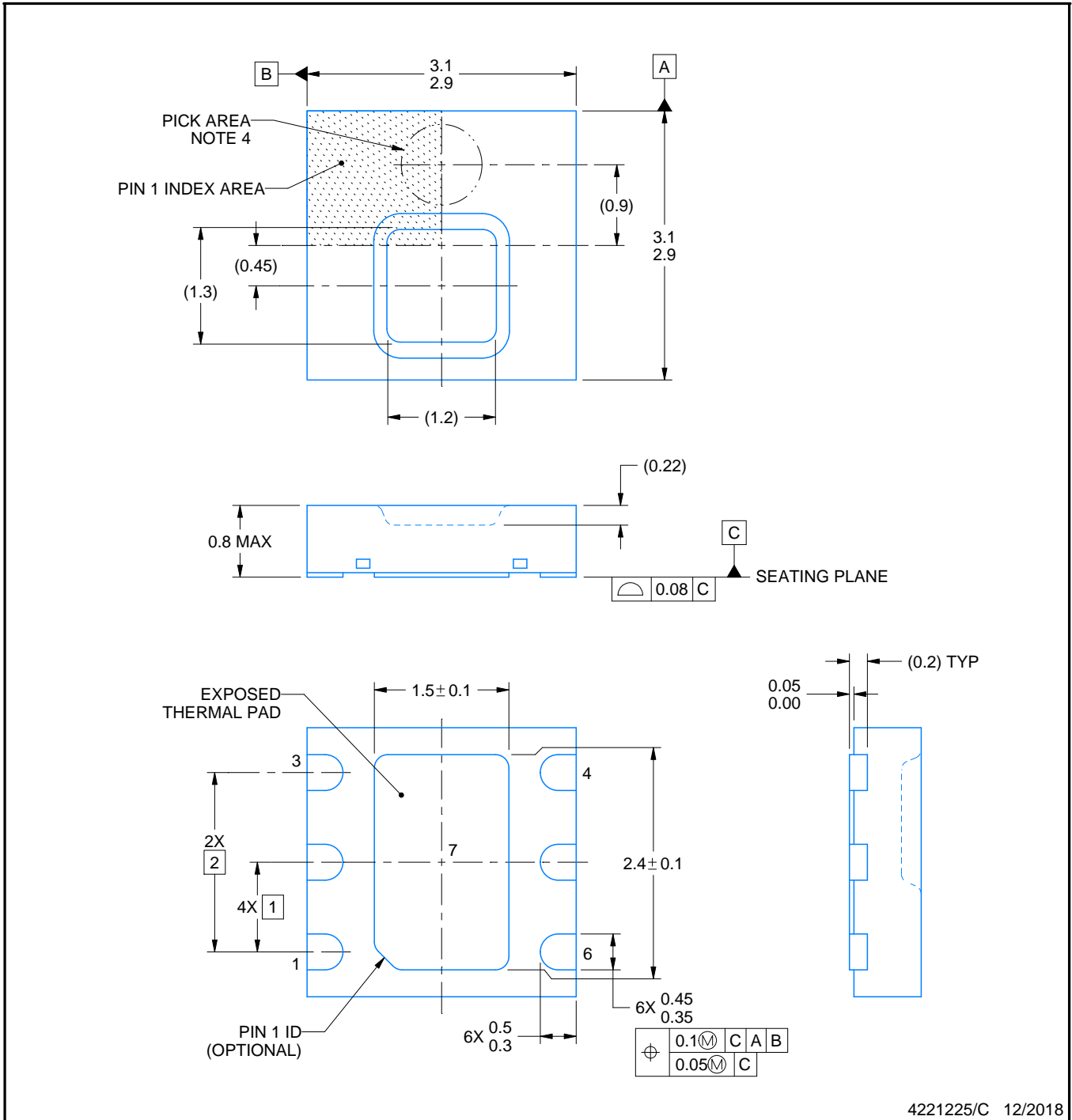

4221225/C 12/2018

NOTES:

- All linear dimensions are in millimeters. Any dimensions in parenthesis are for reference only. Dimensioning and tolerancing per ASME Y14.5M.
- This drawing is subject to change without notice.
- The package thermal pad must be soldered to the printed circuit board for thermal and mechanical performance.
- Pick and place nozzle \varnothing 0.9 mm or smaller recommended.

EXAMPLE STENCIL DESIGN

DMB0006A

WSON - 0.8 mm max height

PLASTIC SMALL OUTLINE - NO LEAD

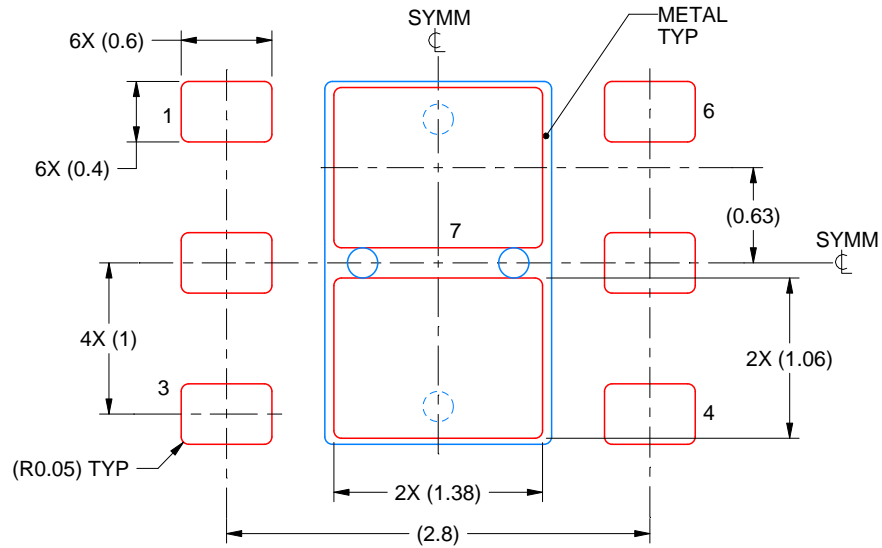

SOLDER PASTE EXAMPLE
BASED ON 0.125 mm THICK STENCIL

EXPOSED PAD 7:
81% PRINTED SOLDER COVERAGE BY AREA UNDER PACKAGE
SCALE:20X

4221225/C 12/2018

NOTES: (continued)

7. Laser cutting apertures with trapezoidal walls and rounded corners may offer better paste release. IPC-7525 may have alternate design recommendations.

IMPORTANT NOTICE AND DISCLAIMER

TI PROVIDES TECHNICAL AND RELIABILITY DATA (INCLUDING DATASHEETS), DESIGN RESOURCES (INCLUDING REFERENCE DESIGNS), APPLICATION OR OTHER DESIGN ADVICE, WEB TOOLS, SAFETY INFORMATION, AND OTHER RESOURCES "AS IS" AND WITH ALL FAULTS, AND DISCLAIMS ALL WARRANTIES, EXPRESS AND IMPLIED, INCLUDING WITHOUT LIMITATION ANY IMPLIED WARRANTIES OF MERCHANTABILITY, FITNESS FOR A PARTICULAR PURPOSE OR NON-INFRINGEMENT OF THIRD PARTY INTELLECTUAL PROPERTY RIGHTS.

These resources are intended for skilled developers designing with TI products. You are solely responsible for (1) selecting the appropriate TI products for your application, (2) designing, validating and testing your application, and (3) ensuring your application meets applicable standards, and any other safety, security, or other requirements. These resources are subject to change without notice. TI grants you permission to use these resources only for development of an application that uses the TI products described in the resource. Other reproduction and display of these resources is prohibited. No license is granted to any other TI intellectual property right or to any third party intellectual property right. TI disclaims responsibility for, and you will fully indemnify TI and its representatives against, any claims, damages, costs, losses, and liabilities arising out of your use of these resources.

TI's products are provided subject to TI's Terms of Sale (www.ti.com/legal/termsofsale.html) or other applicable terms available either on ti.com or provided in conjunction with such TI products. TI's provision of these resources does not expand or otherwise alter TI's applicable warranties or warranty disclaimers for TI products.

Mailing Address: Texas Instruments, Post Office Box 655303, Dallas, Texas 75265
Copyright © 2018, Texas Instruments Incorporated

Looking for pricing, stock, or lifecycle information?

Click below to explore more details on WIN SOURCE:

 [View HDC1080DMBT](#) on WIN SOURCE

 [Texas Instruments](#) Information

Optimize Your Supply Chain with WIN SOURCE Solutions

-  Global Sourcing Solution
-  Obsolete Management
-  Cost Control Management
-  Shortage Management
-  Alternative Solution
-  Excess Inventory Management