



**THE DATASHEET OF
ADIS16210CMLZ**



FEATURES

- Triaxial, digital inclinometer system**
 - ±180° measurement range, roll and pitch axes
 - ±90° gravity axis
 - ±0.1° relative accuracy
- Triaxial, digital accelerometer, high accuracy**
 - ±1.7 g measurement range
 - ±0.05° axis-to-axis alignment
- Digital internal temperature measurements**
- Digital internal power supply measurements**
- Programmable user calibration options**
 - Single command, frame alignment
 - Manual accelerometer bias correction
- Programmable operation and control**
 - Sample rate/filtering
 - Alarm conditions and indicator output
 - Input/output: data ready, alarm, general-purpose
- Power management functions**
- SPI-compatible serial interface**
- Serial number and device ID**
- Single-supply operation: 3.0 V to 3.6 V**
- Calibrated temperature range: -40°C to +85°C**
- 15 mm × 24 mm × 15 mm package with flexible connector**

APPLICATIONS

- Platform control, stabilization, and alignment
- Tilt sensing, inclinometers, and leveling
- Motion/position measurement
- Monitor/alarm devices (security, medical, safety)
- Navigation

GENERAL DESCRIPTION

The **ADIS16210** *iSensor*® is a digital inclinometer system that provides precise measurements for both pitch and roll angles over a full orientation range of ±180°. It combines a MEMS tri-axial acceleration sensor with signal processing, addressable user registers for data collection/programming, and a SPI-compatible serial interface. In addition, the production process includes unit specific calibration for optimal accuracy performance. It also offers digital temperature sensor and power supply measurements together with configuration controls for in-system calibration, sample rate, filtering, alarms, input/output (I/O) configuration, and power management.

The MEMS sensor elements are bound to an aluminum core for tight platform coupling and excellent mechanical stability. An internal clock drives the data sampling system, which eliminates the need for an external clock source. The SPI and data buffer structure provide convenient access to accurate sensor data and configuration controls.

The **ADIS16210** is available in a 15 mm × 24 mm × 15 mm module that provides mounting tabs with M2-sized mounting holes and a flexible, edge terminated connector interface. It has an extended operating temperature range of -40°C to +125°C.

FUNCTIONAL BLOCK DIAGRAM

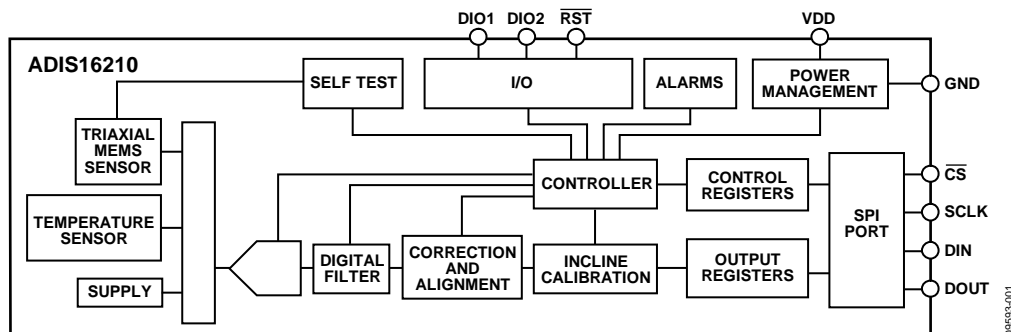

Figure 1.

Rev. E

[Document Feedback](#)

Information furnished by Analog Devices is believed to be accurate and reliable. However, no responsibility is assumed by Analog Devices for its use, nor for any infringements of patents or other rights of third parties that may result from its use. Specifications subject to change without notice. No license is granted by implication or otherwise under any patent or patent rights of Analog Devices. Trademarks and registered trademarks are the property of their respective owners.

One Technology Way, P.O. Box 9106, Norwood, MA 02062-9106, U.S.A.
 Tel: 781.329.4700 ©2011–2019 Analog Devices, Inc. All rights reserved.
[Technical Support](#) www.analog.com

TABLE OF CONTENTS

Features 1

Applications..... 1

General Description 1

Functional Block Diagram 1

Revision History 2

Specifications..... 3

 Timing Specifications 4

Absolute Maximum Ratings..... 5

 ESD Caution..... 5

Pin Configuration and Function Descriptions..... 6

Basic Operation..... 7

 Reading Sensor Data 7

 Device Configuration 7

User Register Map 8

Sensor Data..... 9

 Output Data Registers..... 9

Signal Processing, Bias Correction, and Alignment..... 12

System Tools..... 15

 Global Commands 15

 Input/Output Functions 15

 Device Identification..... 16

 Status/Error Flags 16

 Flash Memory Management..... 16

Alarms..... 17

 System Alarm..... 17

 Static Alarms..... 17

 Dynamic Alarms 17

 Alarm Reporting 17

Applications Information 18

 Mating Connector 18

 Breakout Board..... 18

 PC-Based Evaluation Tools..... 18

Outline Dimensions 20

 Ordering Guide 20

REVISION HISTORY

3/2019—Rev D to Rev. E

Added Endnote 1 to Inclinometers, Relative Accuracy
Parameter, Table 1; Renumbered Sequentially 3

Changes to Table 31 Title to Table 33 Title 14

Added X-Ray Sensitivity Section..... 19

Changes to Ordering Guide 21

3/2018—Rev C to Rev. D

Changes to Figure 4..... 6

Deleted Interface Board Section, Figure 23, and Figure 25;
Renumbered Sequentially..... 18

Added Breakout Board Section, PC-Based Evaluation Tools
Section, and Figure 24; Renumbered Sequentially 18

Added Figure 25..... 19

Changes to Ordering Guide 20

12/2016—Rev. B to Rev. C

Changes to Signal Processing, Bias Correction, and Alignment
Section..... 12

6/2015—Rev. A to Rev. B

Changes to Figure 2..... 4

Change to Figure 57

Changes to User Register Map Section and Table 8.....8

Changes to Signal Processing, Bias Correction, and Alignment
Section, Figure 16, and Accelerometer Bias Correction Section.. 12

Added Table 27, Table 28, and Table 29; Renumbered
Sequentially 12

Changes to Table 30 and Measurement Mode Section 13

Added Two-Axis Mode Section..... 13

Added User Reference Alignment Section, Table 31, Table 32,
and Table 33 14

Change to Table 34..... 15

Moved User Register Save to Flash Memory Section and
Figure 20 15

Changes to Figure 25..... 18

6/2011—Rev. 0 to Rev. A

Changes to Table 1.....3

Changes to Table 23 12

Changes to Figure 24 and Figure 25..... 17

4/2011—Revision 0: Initial Version

SPECIFICATIONS

$T_A = -40^\circ\text{C}$ to $+85^\circ\text{C}$, $V_{DD} = 3.0\text{ V}$ to 3.6 V , unless otherwise noted.

Table 1.

Parameter	Test Conditions/Comments	Min	Typ	Max	Unit
INCLINOMETERS					
Measurement Range		-180		+180	Degrees
Relative Accuracy ¹	$\pm 30^\circ$, $\text{AVG_CNT} \geq 0x0009$, $\mu \pm 3\sigma$		± 0.1		Degrees
	$\pm 60^\circ$, $\text{AVG_CNT} \geq 0x0009$, $\mu \pm 1\sigma$		± 0.1		Degrees
	$\pm 60^\circ$, $\text{AVG_CNT} \geq 0x0009$, $\mu \pm 3\sigma$		± 0.15		Degrees
	$\pm 180^\circ$, $\text{AVG_CNT} \geq 0x0009$, $\mu \pm 1\sigma$		± 0.14		Degrees
	$\pm 180^\circ$, $\text{AVG_CNT} \geq 0x0009$, $\mu \pm 3\sigma$		± 0.21		Degrees
Noise Density	$T_A = 25^\circ\text{C}$, $\text{AVG_CNT} = 0x0000$		± 0.011		$^\circ/\sqrt{\text{Hz}}$
ACCELEROMETERS					
Measurement Range		± 1.7			<i>g</i>
Offset Error	$\mu \pm 1\sigma$		± 1		mg
Sensitivity Error	$\mu \pm 1\sigma$		± 0.0244		%
Nonlinearity	$\pm 1\text{ g}$, $\mu \pm 1\sigma$		± 1	± 2	mg
Misalignment	Axis to axis, deviation from 90° , $\mu \pm 1\sigma$		± 0.05		Degrees
Noise Density	$T_A = 25^\circ\text{C}$, $\text{AVG_CNT} = 0x0000$		190		$\mu\text{g}/\sqrt{\text{Hz}}$
Bandwidth	-3 dB decrease in dc sensitivity, $T_A = 25^\circ\text{C}$		50		Hz
Sensor Resonant Frequency	$T_A = 25^\circ\text{C}$		5.5		kHz
LOGIC INPUTS²					
Input High Voltage, V_{INH}		2.0			V
Input Low Voltage, V_{INL}				0.8	V
Logic 1 Input Current, I_{INH}	$V_{\text{IH}} = 3.3\text{ V}$		± 0.2	± 1	μA
Logic 0 Input Current, I_{INL}	$V_{\text{IL}} = 0\text{ V}$				μA
All Except $\overline{\text{RST}}$			-40	-60	μA
$\overline{\text{RST}}$			-1		mA
Input Capacitance, C_{IN}			10		pF
DIGITAL OUTPUTS²					
Output High Voltage, V_{OH}	$I_{\text{SOURCE}} = 1.6\text{ mA}$	2.4			V
Output Low Voltage, V_{OL}	$I_{\text{SINK}} = 1.6\text{ mA}$			0.4	V
FLASH MEMORY					
Endurance ³		10,000			Cycles
Data Retention ⁴	$T_J = 85^\circ\text{C}$	20			Years
START-UP TIME⁵					
Initial Startup			156		ms
Reset Recovery ⁶	$\overline{\text{RST}}$ pulse low or Register $\text{GLOB_CMD}[7] = 1$		33.8		ms
Sleep Mode Recovery	After $\overline{\text{CS}}$ assertion from high to low		22.3		ms
CONVERSION RATE					
Clock Accuracy	Register $\text{AVG_CNT} = 0x0000$		512		SPS
			3		%
POWER SUPPLY					
Operating voltage range, V_{DD}		3.0	3.3	3.6	V
Power Supply Current	Normal mode, $T_A = 25^\circ\text{C}$		18		mA
	Sleep mode, $T_A = 25^\circ\text{C}$		230		μA

¹ X-ray exposure may degrade this performance metric.

² The digital I/O signals are 5 V tolerant.

³ Endurance is qualified as per JEDEC Standard 22, Method A117, and measured at -40°C , $+25^\circ\text{C}$, $+85^\circ\text{C}$, and $+125^\circ\text{C}$.

⁴ Retention lifetime equivalent at junction temperature (T_J) = 85°C as per JEDEC Standard 22, Method A117. Retention lifetime decreases with junction temperature. See Figure 22.

⁵ The start-up times presented do not include the data capture time, which is dependent on the AVG_CNT register settings.

⁶ The $\overline{\text{RST}}$ pin must be held low for at least 15 ns.

TIMING SPECIFICATIONS

$T_A = 25^\circ\text{C}$, $V_{DD} = 3.3\text{ V}$, unless otherwise noted.

Table 2.

Parameter	Description	Min ¹	Typ	Max	Unit
f_{SCLK}	SCLK frequency	10		830	kHz
t_{STALL}	Stall period between data, between 16 th and 17 th SCLK	40			μs
t_{CS}	Chip select to SCLK edge	48.8			ns
t_{DAV}	DOOUT valid after SCLK edge			100	ns
t_{DSU}	DIN setup time before SCLK rising edge	24.4			ns
t_{DHD}	DIN hold time after SCLK rising edge	48.8			ns
t_{SR}	SCLK rise time			12.5	ns
t_{SF}	SCLK fall time			12.5	ns
$t_{\text{DF}}, t_{\text{DR}}$	DOOUT rise/fall times		5	12.5	ns
t_{SFS}	$\overline{\text{CS}}$ high after SCLK edge	5			ns

¹ Guaranteed by design, not tested.

Timing Diagrams

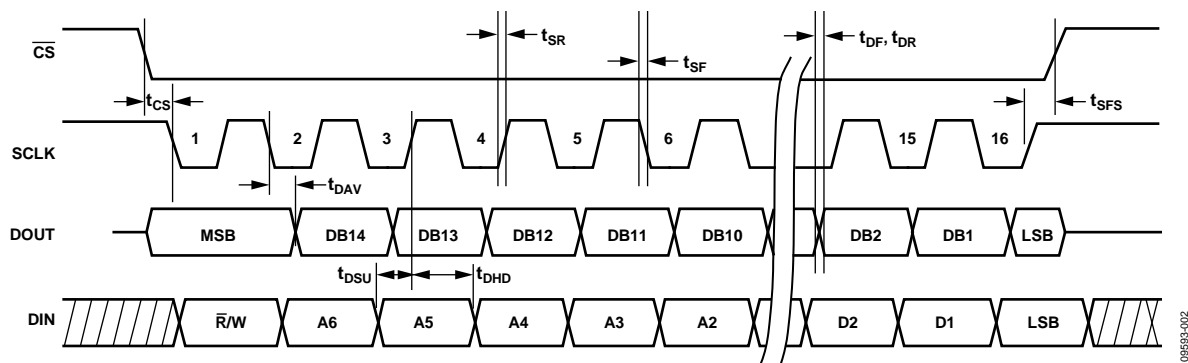

Figure 2. SPI Timing and Sequence

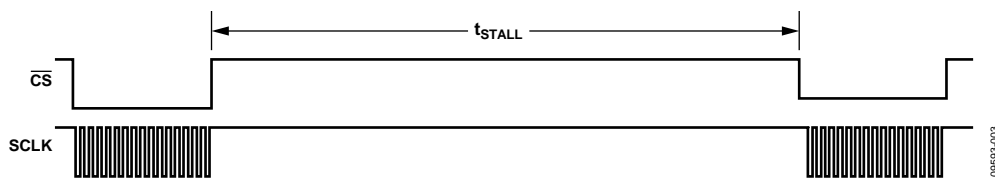

Figure 3. DIN Bit Sequence

ABSOLUTE MAXIMUM RATINGS

Table 3.

Parameter	Rating
Acceleration	
Any Axis, Unpowered	3500 g
Any Axis, Powered	3500 g
VDD to GND	−0.3 V to +6.0 V
Digital Input Voltage to GND	−0.3 V to +5.3 V
Digital Output Voltage to GND	−0.3 V to VDD + 0.3 V
Analog Inputs to GND	−0.3 V to +3.6 V
Operating Temperature Range	−40°C to +125°C
Storage Temperature Range	−65°C to +150°C

Stresses at or above those listed under Absolute Maximum Ratings may cause permanent damage to the product. This is a stress rating only; functional operation of the product at these or any other conditions above those indicated in the operational section of this specification is not implied. Operation beyond the maximum operating conditions for extended periods may affect product reliability.

Table 4. Package Characteristics

Package Type	θ_{JA}	θ_{JC}	Device Weight
15-Lead Module	31°C/W	11°C/W	7.2 grams

ESD CAUTION



ESD (electrostatic discharge) sensitive device. Charged devices and circuit boards can discharge without detection. Although this product features patented or proprietary protection circuitry, damage may occur on devices subjected to high energy ESD. Therefore, proper ESD precautions should be taken to avoid performance degradation or loss of functionality.

PIN CONFIGURATION AND FUNCTION DESCRIPTIONS

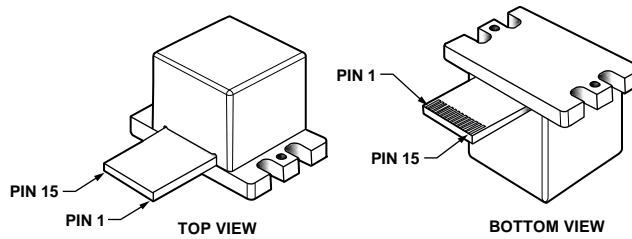

NOTES

1. THE LEADS ARE LOCATED ON THE BOTTOM SIDE OF THE FLEXIBLE CABLE.
2. THE LEAD FINISH IS IMMERSION GOLD OVER THE ELECTROLESS NICKEL.
3. THE THICKNESS OF THE GOLD FINISH IS BETWEEN 0.035 μ m AND 0.150 μ m.
4. PACKAGE IS NOT SUITABLE FOR SOLDER REFLOW ASSEMBLY PROCESSES.
5. EXAMPLE MATING CONNECTOR: AVX CORPORATION
FLAT FLEXIBLE CONNECTOR (FFC)
P/N: 04-6288-015-000-846.

09593-104

Figure 4. Pin Configuration

Table 5. Pin Function Descriptions

Pin No.	Mnemonic	Type ¹	Description
1, 2	VDD	S	Power Supply, 3.3 V.
3, 4, 5, 8	GND	S	Ground.
6, 9	DNC	I	Do Not Connect. Do not connect to these pins.
7	DIO2	I/O	Digital Input/Output Line 2.
10	$\overline{\text{RST}}$	I	Reset, Active Low.
11	DIN	I	SPI, Data Input.
12	DOUT	O	SPI, Data Output. DOUT is an output when $\overline{\text{CS}}$ is low. When $\overline{\text{CS}}$ is high, DOUT is in a three-state, high impedance mode.
13	SCLK	I	SPI, Serial Clock.
14	$\overline{\text{CS}}$	I	SPI, Chip Select.
15	DIO1	I/O	Digital Input/Output Line 1.

¹ S is supply, I is input, O is output, and I/O is input/output.

BASIC OPERATION

The ADIS16210 is an autonomous system that requires no user initialization. Upon receiving a valid power supply, it initializes itself and starts sampling, processing, and loading data into the output registers. When using the factory default configuration, DIO1 provides a data ready signal. The SPI interface enables simple integration with many embedded processor platforms, as shown in Figure 5 (electrical connection) and Table 6 (processor pin descriptions).

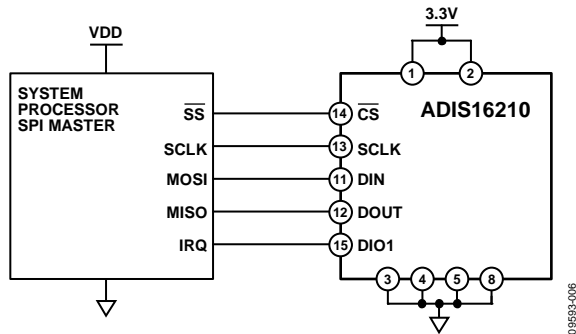

Figure 5. Electrical Connection Diagram

Table 6. Generic Master Processor Pin Names and Functions

Pin Name	Function
SS	Slave select
IRQ	Interrupt request, optional
MOSI	Master output, slave input
MISO	Master input, slave output
SCLK	Serial clock

The ADIS16210 SPI interface supports full duplex serial communication (simultaneous transmit and receive) and uses the bit sequence shown in Figure 9. Table 7 provides a list of the most common settings that initialize the serial port of a processor for the ADIS16210 SPI interface.

Table 7. Generic Master Processor SPI Settings

Processor Setting	Description
Master	ADIS16210 operates as a slave
SCLK Rate ≤ 830 kHz	Maximum serial clock rate
SPI Mode 3	CPOL = 1 (polarity), CPHA = 1 (phase)
MSB-First Mode	Bit sequence
16-Bit Mode	Shift register/data length

READING SENSOR DATA

A single register read requires two 16-bit SPI cycles. The first cycle requests the contents of a register using the bit assignments in Figure 9. The register contents then follow on DOUT, during the second sequence.

Figure 6 includes three single register reads in succession. In this example, the process starts with DIN = 0x0400 to request the contents of the XACCL_OUT register, followed by 0x0600 to request the contents of the YACCL_OUT register, and then 0x0800 to request the contents of the ZACCL_OUT register. Full duplex operation enables processors to use the same 16-bit SPI cycle to read data from DOUT while requesting the next set of data on DIN.

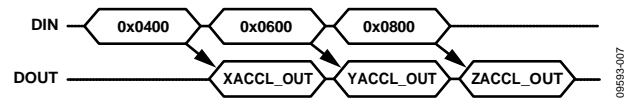

Figure 6. SPI Read Example Remove

Figure 7 provides an example of four SPI signals when reading PROD_ID in a repeating pattern.

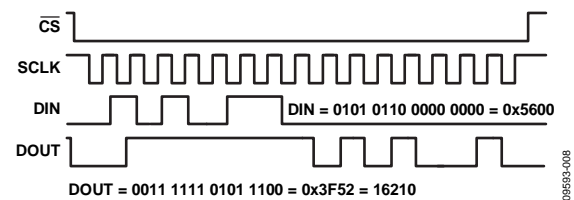

Figure 7. SPI Read Example, Second 16-Bit Sequence

DEVICE CONFIGURATION

The user register map (see Table 8) provides a variety of control registers, which enable optimization for specific applications. The SPI provides access to these registers, one byte at a time, using the bit assignments shown in Figure 9. Each register has 16 bits, where Bits[7:0] represent the lower address and Bits[15:8] represent the upper address. Figure 8 displays the SPI signal pattern for writing 0x07 to Address 0x38, which sets the number of averages to 128 and the sample rate to 4 SPS.

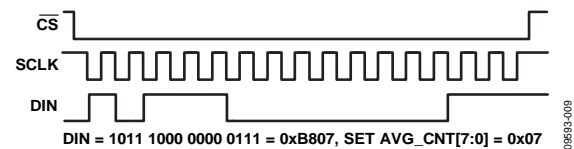
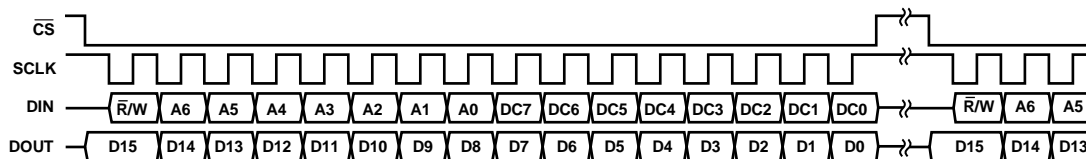

Figure 8. Example SPI Write Pattern



NOTES

1. DOUT BITS ARE PRODUCED ONLY WHEN THE PREVIOUS 16-BIT DIN SEQUENCE STARTS WITH R/W = 0.
2. WHEN CS IS HIGH, DOUT IS IN A THREE-STATE, HIGH IMPEDANCE MODE, WHICH ALLOWS MULTIFUNCTIONAL USE OF THE LINE FOR OTHER DEVICES.

Figure 9. SPI Communication Bit Sequence

USER REGISTER MAP

Table 8. User Register Memory Map¹

Name	R/W	Flash Backup	Address	Size (Bytes)	Function	Reference
FLASH_CNT	R	Yes	0x00	2	Diagnostics, flash write counter (16-bit binary)	Table 43
SUPPLY_OUT	R	No	0x02	2	Output, power supply	Table 20
XACCL_OUT	R	No	0x04	2	Output, x-axis acceleration	Table 9
YACCL_OUT	R	No	0x06	2	Output, y-axis acceleration	Table 10
ZACCL_OUT	R	No	0x08	2	Output, z-axis acceleration	Table 11
TEMP_OUT	R	No	0x0A	2	Output, internal temperature	Table 18
XINCL_OUT	R	No	0x0C	2	Output, $\pm 180^\circ$ x-axis inclination	Table 13
YINCL_OUT	R	No	0x0E	2	Output, $\pm 180^\circ$ y-axis inclination	Table 14
ZINCL_OUT	R	No	0x10	2	Output, $\pm 180^\circ$ z-axis inclination	Table 15
XACCL_NULL	R/W	Yes	0x12	2	Calibration, x-axis acceleration offset null	Table 24
YACCL_NULL	R/W	Yes	0x14	2	Calibration, y-axis acceleration offset null	Table 25
ZACCL_NULL	R/W	Yes	0x16	2	Calibration, z-axis acceleration offset null	Table 26
X_ALIGN_REF	R	Yes	0x18	2	Calibration, x-axis alignment reference	Table 31
Y_ALIGN_REF	R	Yes	0x1A	2	Calibration, y-axis alignment reference	Table 32
Z_ALIGN_REF	R	Yes	0x1C	2	Calibration, z-axis alignment reference	Table 33
Reserved	N/A	N/A	0x1E	2	Reserved, do not write to these locations	N/A
ALM_MAG_X	R/W	Yes	0x20	2	Alarm, x-axis amplitude threshold	Table 45
ALM_MAG_Y	R/W	Yes	0x22	2	Alarm, y-axis amplitude threshold	Table 46
ALM_MAG_Z	R/W	Yes	0x24	2	Alarm, z-axis amplitude threshold	Table 47
ALM_MAG_S	R/W	Yes	0x26	2	Alarm, system alarm threshold	Table 48
ALM_SMPL_X	R/W	Yes	0x28	2	Alarm, x-axis sample period	Table 49
ALM_SMPL_Y	R/W	Yes	0x2A	2	Alarm, y-axis sample period	Table 50
ALM_SMPL_Z	R/W	Yes	0x2C	2	Alarm, z-axis sample period	Table 51
ALM_CTRL	R/W	Yes	0x2E	2	Operation, alarm control	Table 44
Reserved	N/A	N/A	0x30	2	Reserved	N/A
GPIO_CTRL	R/W	Yes	0x32	2	Operation, general I/O configuration and data	Table 37
MSC_CTRL	R/W	Yes	0x34	2	Operation, orientation mode	Table 30
DIO_CTRL	R/W	Yes	0x36	2	Operation, digital I/O configuration and data	Table 36
AVG_CNT	R/W	Yes	0x38	2	Operation, decimation filter configuration	Table 22
SLP_CNT	R/W	Yes	0x3A	2	Operation, sleep count	Table 35
DIAG_STAT	R	No	0x3C	2	Diagnostics, system status register	Table 42
GLOB_CMD	W	No	0x3E	2	Operation, system command register	Table 34
Reserved	N/A	N/A	0x40 to 0x51	16	Reserved	N/A
LOT_ID1	R	N/A	0x52	2	Lot identification, Code 1	Table 38
LOT_ID2	R	N/A	0x54	2	Lot identification, Code 2	Table 39
PROD_ID	R	N/A	0x56	2	Production identification number	Table 40
SERIAL_NUM	R	N/A	0x58	2	Serial number	Table 41
Reserved	N/A	N/A	0x5A to 0x06F	22	Reserved	N/A
XACCL_BIAS	R/W	Yes	0x70	2	Calibration, x-axis accelerometer internal bias	Table 27
YACCL_BIAS	R/W	Yes	0x72	2	Calibration, y-axis accelerometer internal bias	Table 28
ZACCL_BIAS	R/W	Yes	0x74	2	Calibration, z-axis accelerometer internal bias	Table 29

¹ N/A means not applicable.

SENSOR DATA

OUTPUT DATA REGISTERS

The ADIS16210 provides a set of output registers for three orthogonal axes of acceleration: incline angles, internal temperature, and power supply.

Accelerometers

The accelerometers respond to both static (gravity) and dynamic acceleration using the polarity shown in Figure 10. XACCL_OUT (see Table 9), YACCL_OUT (see Table 10), and ZACCL_OUT (see Table 11) provide user access to digital calibrated accelerometer data for each axis. For example, use DIN = 0x0400 to request the x-axis data (XACCL_OUT). After reading the contents of one of these registers, convert the 16-bit, twos complement number into a decimal equivalent, and then divide that number by 16,384 to convert the measurement into units of gravity (g). Table 12 provides several examples of this data format.

Table 9. XACCL_OUT (Base Address = 0x04), Read Only

Bits	Description
[15:0]	X-axis accelerometer output data, twos complement, 1 LSB = $1 g \div 16,384 = \sim 61 \mu g/LSB$, 0 g = 0x0000

Table 10. YACCL_OUT (Base Address = 0x06), Read Only

Bits	Description
[15:0]	Y-axis accelerometer output data, twos complement, 1 LSB = $1 g \div 16,384 = \sim 61 \mu g/LSB$, 0 g = 0x0000

Table 11. ZACCL_OUT (Base Address = 0x08), Read Only

Bits	Description
[15:0]	Z-axis accelerometer output data, twos complement, 1 LSB = $1 g \div 16,384 = \sim 61 \mu g/LSB$, 0 g = 0x0000

Table 12. Accelerometer Data Format Examples

Orientation (g)	Decimal	Hex	Binary
+1.7	+27,853	0x6CCD	0110 1100 1100 1101
+1	+16,384	0x4000	0100 0000 0000 0000
+2/16,384	+2	0x0002	0000 0000 0000 0010
+1/16,384	+1	0x0001	0000 0000 0000 0001
0	0	0x0000	0000 0000 0000 0000
-1/16,384	-1	0xFFFF	1111 1111 1111 1111
-2/16,384	-2	0xFFFE	1111 1111 1111 1110
-1	-16,384	0xC000	1100 0000 0000 0000
-1.7	-27,853	0x9333	1001 0011 0011 0011

Inclinometers

The XINCL_OUT (see Table 13), YINCL_OUT (see Table 14), and ZINCL_OUT (see Table 15) registers provide access to incline angle data for each axis. For example, set DIN = 0x0E00 to request y-axis data (YINCL_OUT). Use the following process to translate the contents of these registers into degrees (°):

1. Convert the 16-bit, twos complement number into a decimal equivalent.
2. Multiply the decimal equivalent by 180.
3. Divide the result of Step 2 by 32,768.

Table 16 provides several examples of this data format.

Table 13. XINCL_OUT (Base Address = 0x0C), Read Only

Bits	Description
[15:0]	X-axis inclinometer output data, binary, 0° = 0x0000, 1 LSB = $180^\circ/32,768 = \sim 0.0055^\circ/LSB$

Table 14. YINCL_OUT (Base Address = 0x0E), Read Only

Bits	Description
[15:0]	Y-axis inclinometer output data, binary, 0° = 0x0000, 1 LSB = $180^\circ/32,768 = \sim 0.055^\circ/LSB$

Table 15. ZINCL_OUT (Base Address = 0x10), Read Only

Bits	Description
[15:0]	Z-axis inclinometer output data, binary, 0° = 0x0000, 1 LSB = $180^\circ/32,768 = \sim 0.0055^\circ/LSB$

Table 16. Incline Angle Data Format Examples

Orientation	Decimal	Hex	Binary
+179.9945°	+32,767	0x7FFF	0111 1111 1111 1111
+0.011°	+2	0x0002	0000 0000 0000 0010
+0.0055°	+1	0x0001	0000 0000 0000 0001
0°	0	0x0000	0000 0000 0000 0000
-0.0055°	-1	0xFFFF	1111 1111 1111 1111
-0.011°	-2	0xFFFE	1111 1111 1111 1110
-180°	-32,768	0x8000	1000 0000 0000 0000

Figure 10 through Figure 15 provide orientation examples and the associated output values for each accelerometer and inclinometer register. These examples assume the factory default configuration for the gravity vector (z-axis, pointed up). See the MSC_CTRL (see Table 30) for additional options for gravity vector definitions.

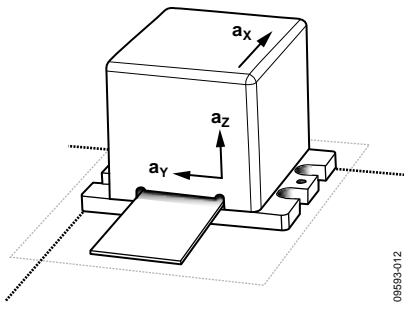

Figure 10. Inclinometer Output Example, 0° Tilt

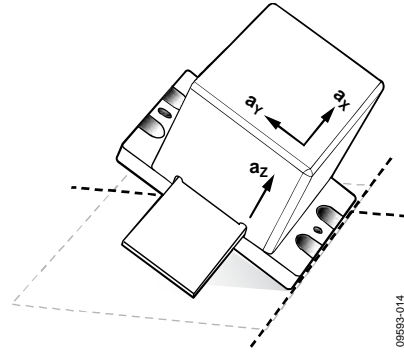

Figure 13. Inclinometer Output Example, +30° Y-Axis Tilt

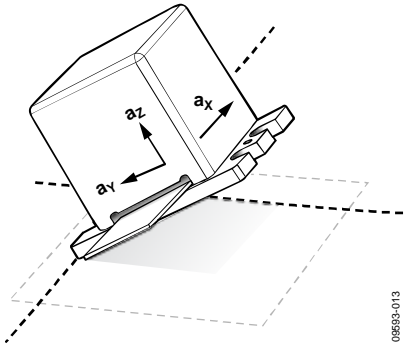

Figure 11. Inclinometer Output Example, -30° Y-Axis Tilt

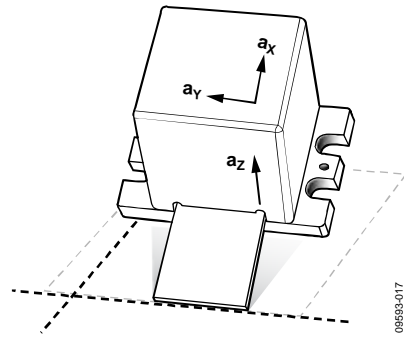

Figure 14. Inclinometer Output Example, +30° X-Axis Tilt

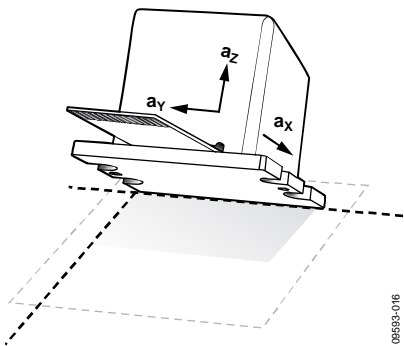

Figure 12. Inclinometer Output Example, -30° X-Axis Tilt

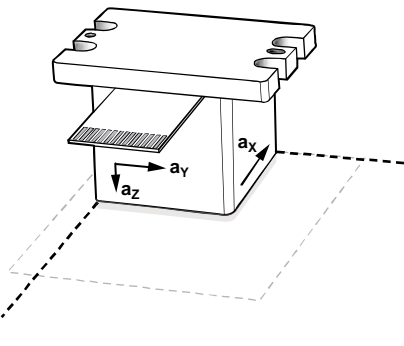

Figure 15. Inclinometer Output Example, 180° Tilt

Table 17. Orientation/Output Examples for Z-Axis Gravity Orientation¹

Register	Figure 10	Figure 11	Figure 12	Figure 13	Figure 14	Figure 15
XACCL_OUT	0	0	-8192	0	+8192	0
YACCL_OUT	0	-8192	0	+8192	0	0
ZACCL_OUT	+16,384	+14,189	+14,189	+14,189	+14,189	-16,384
XINCL_OUT	0	0	-5462	0	+5462	-32,768
YINCL_OUT	0	-5462	0	+5462	0	-32,768
ZINCL_OUT	+16,384	+10,922	+10,922	+10,922	+10,922	-16,384

¹ Register setting for Z-axis gravity orientation is MSC_CTRL[7:0] = xxxx xx10.

Internal Temperature

The TEMP_OUT register (see Table 18) provides access to an internal temperature measurement. Set DIN = 0x0A00 to request the contents of this register. Use the following process to translate the contents of TEMP_OUT into degrees Celsius (°C):

1. Convert the 12-bit binary number into a decimal equivalent.
2. Subtract 1278 from the decimal equivalent.
3. Multiply the result of Step 2 by -0.47 .
4. Add 25 to the result of Step 3.

Table 19 provides several examples of this data format. Note that this internal temperature measurement provides an indicator of condition changes, not an absolute measurement of conditions outside of the package.

Table 18. TEMP_OUT (Base Address = 0x0A), Read Only

Bits	Description
[15:0]	Internal temperature data, binary format, sensitivity = $-0.47^{\circ}/\text{LSB}$, $+25^{\circ}\text{C} = 1278 \text{ LSB} = 0x04FE$

Table 19. Internal Temperature Data Format Examples

Temperature (°C)	LSB	Hex	Binary
+125	1065	0x0429	0000 0100 0010 1001
25 + 0.47	1277	0x04FD	0000 0100 1111 1101
+25	1278	0x04FE	0000 0100 1111 1110
25 – 0.047	1279	0x04FF	0000 0100 1111 1111
0	1331	0x0533	0000 0101 0011 0011
–40	1416	0x0588	0000 0101 1000 1000

Power Supply

The SUPPLY_OUT register (see Table 20) provides a digital measurement for the supply voltage on the VDD pins (see Table 5). Set DIN = 0x0200 to request the contents of this register. Use the following process to translate the contents of SUPPLY_OUT into volts (V):

1. Convert the 16-bit binary number into a decimal equivalent.
2. Multiply the decimal equivalent by 5.
3. Divide the result of Step 2 by 32,768.

Table 21 provides several examples of this data format.

Table 20. SUPPLY_OUT (Base Address = 0x02), Read Only

Bits	Description
[15:0]	Power supply measurement data, binary format, 1 LSB = $5 \div 32,768 = \sim 152.6 \mu\text{V}$, 0 V = 0x0000

Table 21. Power Supply Data Format Examples

Supply Level (V)	LSB	Hex	Binary
3.6	23,593	0x5C29	0101 1100 0010 1001
3.3 + (5 \div 32,768)	21,628	0x547C	0101 0100 0111 1100
3.3	21,627	0x547B	0101 0100 0111 1011
3.3 – (5 \div 32,768)	21,626	0x547A	0101 0100 0111 1010
3.0	19,661	0x4CCD	0100 1100 1100 1101

SIGNAL PROCESSING, BIAS CORRECTION, AND ALIGNMENT

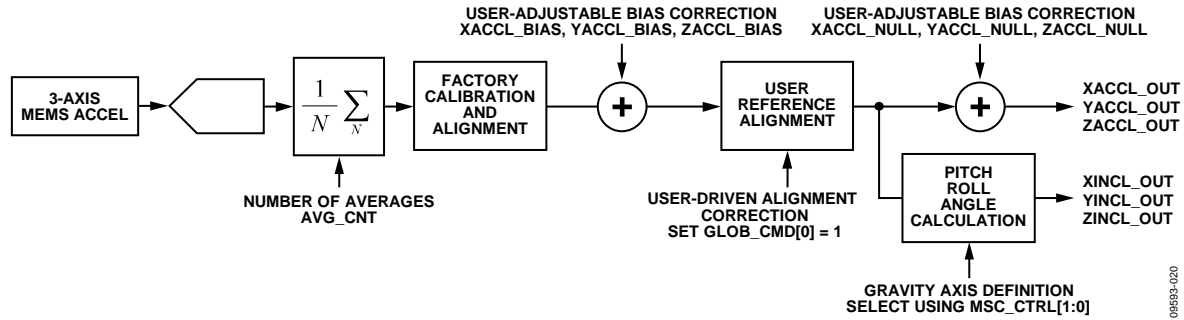

Figure 16. Sensor Signal Processing Diagram (Each Axis)

The ADIS16210 provides user controls for digital filtering, accelerometer bias correction, gravity vector definition, and the measurement mode.

Digital Filtering

The digital filter uses an averaging/decimating architecture to produce a low-pass response. The AVG_CNT register (see Table 22) provides access to the average factor, m, which determines the number of averages (N) in the filtering stage. Table 23 provides the resulting cutoff frequency (f_c) and output register update rate (f_s) associated with each setting in AVG_CNT.

Table 22. AVG_CNT (Base Address = 0x38), Read/Write

Bits	Description (Default = 0x0009)
[15:4]	Not used
[3:0]	Average factor, m, binary format Number of averages, $N = 2^m$

Table 23. AVG_CNT Sample Rate, Bandwidth

AVG_CNT[7:0]	m	N	f_s (Output)	f_c (-3 dB)	Noise (p-p)
0x0000	0	1	512	48.2	±0.32
0x0001	1	2	256	44.6	±0.30
0x0002	2	4	128	36.1	±0.27
0x0003	3	8	64	23.9	±0.22
0x0004	4	16	32	13.5	±0.17
0x0005	5	32	16	7.0	±0.12
0x0006	6	64	8	3.5	±0.09
0x0007	7	128	4	1.8	±0.06
0x0008	8	256	2	0.89	±0.04
0x0009	9	512	1	0.44	±0.03
0x000A	10	1024	0.5	0.22	±0.02
0x000B	11	2048	0.25	0.11	±0.02

Accelerometer/Inclinometer Resolution

When m (AVG_CNT[7:0] in Table 23) is between 0 and 4, the resolution in the accelerometer and inclinometer registers is equal to m + 12 bits. When m is greater than 4, the resolution in the accelerometer and inclinometer registers is 16 bits.

Accelerometer Bias Correction

The XACCL_NULL (Table 24), YACCL_NULL (see Table 25), and ZACCL_NULL (see Table 26) registers add to the accelerometer outputs to provide a bias adjustment function. They use the same format as each accelerometer output register. For example, set XACCL_NULL = 0x00F (DIN = 0x9300, 0x920F) to increase the x-axis bias by 15 LSB, or 915.5 μg ($15 \div 16,384$).

Table 24. XACCL_NULL (Base Address = 0x12), Read/Write

Bits	Description (Default = 0x0000)
[15:0]	Same format as XACCL_OUT, see Table 9

Table 25. YACCL_NULL (Base Address = 0x14), Read/Write

Bits	Description (Default = 0x0000)
[15:0]	Same format as YACCL_OUT, see Table 10

Table 26. ZACCL_NULL (Base Address = 0x16), Read/Write

Bits	Description (Default = 0x0000)
[15:0]	Same format as ZACCL_OUT, see Table 11

The XACCL_BIAS (see Table 27), YACCL_BIAS (see Table 28), and ZACCL_BIAS (see Table 34) registers add to the accelerometer signals, prior to the angle computation function.

Table 27. XACCL_BIAS (Base Address = 0x70), Read/Write

Bits	Description (Default = 0x0000)
[15:0]	Same format as XACCL_OUT, see Table 9

Table 28. YACCL_BIAS (Base Address = 0x72), Read/Write

Bits	Description (Default = 0x0000)
[15:0]	Same format as YACCL_OUT, see Table 10

Table 29. ZACCL_BIAS (Base Address = 0x74), Read/Write

Bits	Description (Default = 0x0000)
[15:0]	Same format as ZACCL_OUT, see Table 11

Gravity Vector Axis Definition

The ADIS16210 uses the following equations to translate calibrated, triaxial accelerometer data into incline angles:

$$\theta = \text{atan2} \left(\frac{a_P}{K_{GP} \sqrt{a_R^2 + a_G^2}} \right)$$

$$\phi = \text{atan2} \left(\frac{a_R}{K_{GP} \sqrt{a_P^2 + a_G^2}} \right)$$

$$\psi = \text{atan2} \left(\frac{a_G}{K_{GP} \sqrt{a_P^2 + a_R^2}} \right)$$

The pitch (θ) and roll (ϕ) axes provide $\pm 180^\circ$ of measurement range, whereas the gravity (ψ) axis provides $\pm 90^\circ$ of measurement range. The MSC_CTRL register (see Table 30) provides three control bits that set the orientation of the device, which assigns each accelerometer to an angle axis (pitch, roll, and gravity).

Table 30. MSC_CTRL (Base Address = 0x34), Read/Write

Bits	Value	Description (Default = 0x0002)
[15:10]		Not used
[9]	0	Number of axes in angle calculation Three axes
	1	Two axes
[8]	0	Measurement mode Inclinometer
	1	Accelerometer
[7:3]		Not used
[2]	1	Gravity vector polarity, K_{GP} Negative, pointing down (-)
	0	Positive, pointing up (+)
[1:0]	00	Gravity vector orientation X = gravity vector Y = pitch axis (θ , a_P) Z = roll axis (ϕ , a_R)
	01	Y = gravity vector X = pitch axis (θ , a_P) Z = roll axis (ϕ , a_R)
	10	Z = gravity vector X = pitch axis (θ , a_P) Y = roll axis (ϕ , a_R)
	11	Reserved

For best use of the available range and accuracy, use Bits[2:0] in the MSC_CTRL register to establish the accelerometer that best aligns with gravity when the device is oriented at its reference point. For example, Figure 10 provides a reference point orientation, where the z-axis accelerometer aligns with gravity, for which the factory default setting for MSC_CTRL (0x0002) is optimal.

Bits[1:0] provide a control for setting the axis that is most closely aligned with the gravity vector and assigns the pitch and roll axes. Bit 2 provides a control for the direction/polarity of this. Therefore, when using the factory default setting for MSC_CTRL, read XINCL_OUT for the pitch angle and YINCL_OUT for the roll angle measurements. Figure 17, Figure 18, and Figure 19 provide several examples for these settings, which are different from the factory programmed settings.

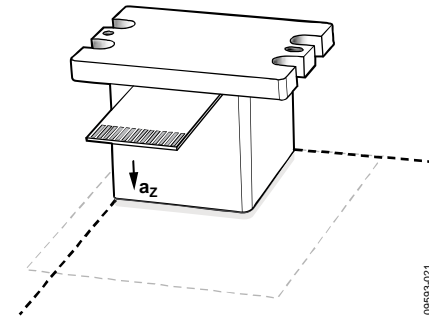

Figure 17. Z-Axis Gravity Vector, Negative Polarity
Set MSC_CTRL = 0x0006 (DIN = 0xB406)

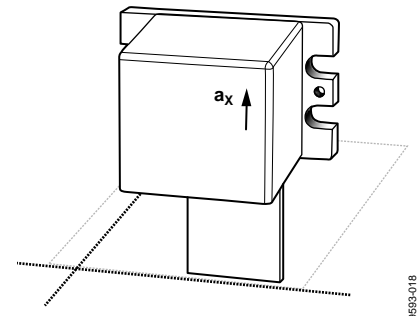

Figure 18. X-Axis Gravity Vector, Positive Polarity
Set MSC_CTRL = 0x0000 (DIN = 0xB400)

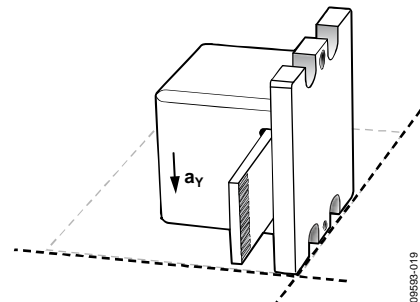

Figure 19. Y-Axis Gravity Vector, Negative Polarity
Set MSC_CTRL = 0x0005 (DIN = 0xB405)

Measurement Mode

MSC_CTRL[8] establishes the primary measurement function. Selecting acceleration mode (MSC_CTRL[8] = 1, DIN = 0xB501) disables a nonlinear correction term that is only relevant in the angle computation.

Two-Axis Mode

In cases where two-axis computations are preferred, set `MSC_CTRL[9] = 1` (`DIN = 0xB502`). This simplifies the pitch and roll equations to the following:

$$\theta = \text{atan2} \left(\frac{a_P}{K_{GP} \times a_G} \right)$$

$$\phi = \text{atan2} \left(\frac{a_R}{K_{GP} \times a_G} \right)$$

User Reference Alignment

Set `GLOB_CMD[0] = 1` (`DIN = 0xBE01`) to trigger the user reference alignment function, which observes the accelerometer values and computes a rotation matrix that reorients them to the reference frame definition, per the settings in `MSC_CTRL[2:0]`. For example, when using the default setting for these bits, executing this command remaps the accelerometers to the following values: `XACCL_OUT = 0 g`, `YACCL_OUT = 0 g` and `ZACCL_OUT = 1 g`.

The initial accelerometer readings, prior to the alignment process, are available in the `X_ALIGN_REF` (see Table 31), `Y_ALIGN_REF` (see Table 32), and `Z_ALIGN_REF` (see Table 33) registers.

Table 31. X_ALIGN_REF (Base Address = 0x18), Read

Bits	Description (Default = 0x0000)
[15:0]	Same format as <code>XACCL_OUT</code> , see Table 9

Table 32. Y_ALIGN_REF (Base Address = 0x1A), Read

Bits	Description (Default = 0x0000)
[15:0]	Same format as <code>YACCL_OUT</code> , see Table 10

Table 33. Z_ALIGN_REF (Base Address = 0x1C), Read

Bits	Description (Default = 0x0000)
[15:0]	Same format as <code>ZACCL_OUT</code> , see Table 11

SYSTEM TOOLS

The ADIS16210 provides control registers for the following system level functions: global commands (including self test), input/output functions, device identification, status/error flags, and flash memory management.

GLOBAL COMMANDS

The GLOB_CMD register (see Table 34) provides an array of single write commands. Set the assigned bit to 1 to activate each function. Proper execution of each command depends on the power supply being within normal limits and no SPI communication, during the process times listed in Table 34.

Table 34. GLOB_CMD (Base Address = 0x3E), Write Only

Bits	Description	Process Time ¹
[15:8]	Not used	Not applicable
[7]	Software reset	33.7 ms
[6]	User register save to flash memory	28.0 ms
[5]	Flash memory test	31.3 ms
[4]	Clear DIAG_STAT register	93 μ s
[3]	Restore factory default configuration	68.6 ms
[2]	Self test	53.7 ms
[1]	Power-down	Not applicable
[0]	User reference alignment	Not applicable

¹ This indicates the typical duration of time between the command write and the device returning to normal operation.

Software Reset

Set GLOB_CMD[7] = 1 (DIN = 0xBE80) to execute an internal reset, which flushes all data and restores the register values to the values that are stored in nonvolatile flash memory.

User Register Save to Flash Memory

Figure 20 provides a diagram of the dual memory structure used to manage operation and store user settings. Writing configuration data to a control register updates its SRAM contents, which are volatile. Most of the user registers have mirror locations in flash memory (see Table 8, for a yes in the Flash Backup column). Use the manual flash backup command in GLOB_CMD[6] (DIN = 0xBE40) to save these settings into the nonvolatile flash memory. The flash backup process requires a valid power supply level and zero SPI communication to execute.

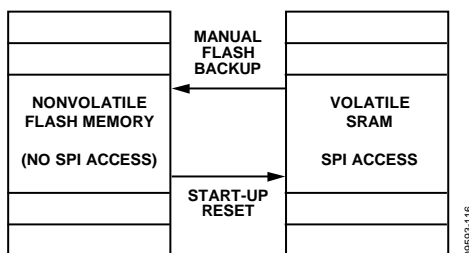

Figure 20. SRAM and Flash Memory Diagram

Flash Memory Test

Set GLOB_CMD[5] = 1 (DIN = 0xBE20) to execute the internal flash memory test routine, which computes a check sum verification of all flash memory locations that are not configurable through user commands.

Self Test

Set GLOB_CMD[2] = 1 (DIN = 0xBE04) to execute an internal test routine that exercises the sensors and signal processing circuit, then writes the pass/fail result to Bit 5 of the DIAG_STAT register.

Power-Down

Set GLOB_CMD[1] = 1 (DIN = 0xBE02) to put the device into sleep mode. Use the SLP_CNT register to establish the duration of the sleep period. For example, set SLP_CNT[7:0] = 0x64 (DIN = 0xBA64) to set the sleep period to 50 seconds. Set SLP_CNT[7:0] = 0x00 (DIN = 0xBA00) to establish the sleep period as indefinite. Indefinite sleep mode requires one of the three actions to wake up: negative assertion of the CS line (22.3 ms wake-up time), a negative assertion of the RST line (33.8 ms recovery time), or a power cycle (156 ms start-up time).

Table 35. SLP_CNT (Base Address = 0x3A), Read/Write

Bits	Description (Default = 0x0000)
[15:8]	Not used
[7:0]	Binary, sleep time, 0.5 seconds/LSB 0x00 = indefinite sleep mode

INPUT/OUTPUT FUNCTIONS

The DIO_CTRL register (see Table 36) provides configuration control options for the two digital I/O lines. Bits[5:4] and Bit 1 assign the function and active polarity for DIO2. Bits[3:2] and Bit 0 assigned the function and polarity for DIO1.

Table 36. DIO_CTRL (Base Address = 0x36), Read/Write

Bits	Value	Description (Default = 0x0007)
[15:6]		Not used
[5:4]	00 01 10 11	DIO2 function selection General-purpose Data ready Alarm indicator Busy signal
[3:2]	00 01 10 11	DIO1 function selection General-purpose Data ready Alarm indicator Busy signal
[1]	1 0	DIO2 polarity Active high Active low
[0]	1 0	DIO1 polarity active high active low

Data Ready Indicator

The data ready signal pulses to its inactive state when loading fresh data into the output registers, then back to its active state when the register update process completes, as shown in Figure 21, which shows the factory default operation. Set DIO_CTRL[7:0] = 0x13 (DIN = 0xB613) to change the data ready assignment to DIO2 with a positive polarity.



Figure 21. Data Ready Operation, DIO_CTRL[7:0] = 0x05

Alarm Indicator

Set DIO_CTRL[7:0] = 0x27 (DIN = 0xB627) to configure DIO2 as an alarm indicator with an active high polarity. The alarm indicator transitions to its active state when the acceleration or system data exceeds the threshold settings in the ALM_MAG_x registers. Set GLOB_CMD[4] = 1 (DIN = 0xBF10) to clear the DIAG_STAT error flags and restore the alarm indicator to its inactive state.

General-Purpose Input/Output

If DIO_CTRL configures either DIO1 or DIO2 as a general-purpose digital line, use the GPIO_CTRL register (see Table 37) to configure its input/output direction, set the output level when configured as an output, and monitor the status of an input. For example, set DIO_CTRL[3:0] = 0x00 (DIN = 0xB600) to establish DIO1 as a general-purpose line, set GPIO_CTRL[0] = 1 (DIN = 0xB201) to establish DIO1 as an output, and set GPIO_CTRL[8] = 1 (DIN = 0xB301) to set DIO1 high.

Table 37. GPIO_CTRL (Base Address = 0x32), Read/Write

Bits	Description (Default = 0x0000)
[15:10]	Not used
[9]	DIO2 output level, 1 = high, 0 = low
[8]	DIO1 output level, 1 = high, 0 = low
[7:2]	Reserved
[1]	DIO2 direction control, 1 = output, 0 = input
[0]	DIO1 direction control, 1 = output, 0 = input

DEVICE IDENTIFICATION

Table 38. LOT_ID1 (Base Address = 0x52), Read Only

Bits	Description
[15:0]	Lot identification code

Table 39. LOT_ID2 (Base Address = 0x54), Read Only

Bits	Description
[15:0]	Lot identification code

Table 40. PROD_ID (Base Address = 0x56), Read Only

Bits	Description (Default = 0x3F52)
[15:0]	0x3F52 = 16,210

Table 41. SERIAL_NUM (Base Address = 0x58), Read Only

Bits	Description
[15:0]	Serial number, lot specific

STATUS/ERROR FLAGS

The DIAG_STAT register, in Table 42, provides a number of status/error flags that reflect the conditions observed during a capture, during SPI communication and diagnostic tests. A 1 indicates an error condition and all of the error flags are sticky, which means that they remain until they are reset by setting GLOB_CMD[4] = 1 (DIN = 0xBE10). The flag in Bit 3 of the DIAG_STAT register indicates that the total number of SCLK clocks is not a multiple of 16. Set DIN = 0x3C00 to read this register.

Table 42. DIAG_STAT (Base Address = 0x3C), Read Only

Bits	Description (Default = 0x0000)
[15:12]	Not used
[11]	Alarm S flag
[10]	Alarm Z flag
[9]	Alarm Y flag
[8]	Alarm X flag
[7]	Data ready
[6]	Flash test
[5]	Self test
[4]	Not used
[3]	SPI failure
[2]	Flash update failure
[1]	VDD > 3.625
[0]	VDD < 2.975

FLASH MEMORY MANAGEMENT

Set GLOB_CMD[5] = 1 (DIN = 0xBE20) to run an internal checksum test on the flash memory, which reports a pass/fail result to DIAG_STAT[6]. The FLASH_CNT register (see Table 43) provides a running count of flash memory write cycles. This is a tool for managing the endurance of the flash memory. Figure 22 quantifies the relationship between data retention and junction temperature.

Table 43. FLASH_CNT (Base Address = 0x00), Read Only

Bits	Description
[15:0]	Binary counter for writing to flash memory

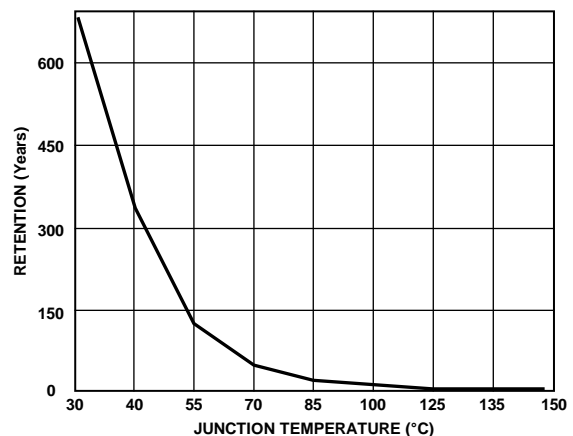

Figure 22. Flash/EE Memory Data Retention

ALARMS

There are four independent alarms, which provide trigger level and polarity controls. The ALM_CTRL register (see Table 44) provides individual settings for data source selection (Bits[7:4]), static and dynamic comparison (Bits[14:12]), trigger direction/polarity (Bits[11:8]), and alarm enable (Bits[3:0]).

Table 44. ALM_CTRL (Base Address = 0x2E), Read/Write

Bits	Description (Default = 0x0000)
[15]	Not used
[14]	Alarm Z, dynamic control 1 = dynamic, 0 = static
[13]	Alarm Y, dynamic control 1 = dynamic, 0 = static
[12]	Alarm X, dynamic control 1 = dynamic, 0 = static
[11]	Alarm S, comparison polarity 1 = SUPPLY_OUT/TEMP_OUT > ALM_MAG_S 0 = SUPPLY_OUT/TEMP_OUT < ALM_MAG_S
[10]	Alarm Z, comparison polarity 1 = ZACCL_OUT/ZINCL_OUT > ALM_MAG_Z 0 = ZACCL_OUT/ZINCL_OUT < ALM_MAG_Z
[9]	Alarm Y, comparison polarity 1 = YACCL_OUT/YINCL_OUT > ALM_MAG_Y 0 = YACCL_OUT/YINCL_OUT < ALM_MAG_Y
[8]	Alarm X, comparison polarity 1 = XACCL_OUT/XINCL_OUT > ALM_MAG_X 0 = XACCL_OUT/XINCL_OUT < ALM_MAG_X
[7]	Alarm S, source selection 1 = SUPPLY_OUT, 0 = TEMP_OUT
[6]	Alarm Z, source selection 1 = ZINCL_OUT, 0 = ZACCL_OUT
[5]	Alarm Y, source selection 1 = YINCL_OUT, 0 = YACCL_OUT
[4]	Alarm X, source selection 1 = XINCL_OUT, 0 = XACCL_OUT
[3]	Alarm S, enable 1 = enabled, 0 = disabled
[2]	Alarm Z, enable 1 = enabled, 0 = disabled
[1]	Alarm Y, enable 1 = enabled, 0 = disabled
[0]	Alarm X, enable 1 = enabled, 0 = disabled

SYSTEM ALARM

The system alarm monitors either power supply or internal temperature, according to the user selections in ALM_CTRL[11], ALM_CTRL[7], ALM_CTRL[3], and the ALM_MAG_S register in Table 48. For example, set ALM_CTRL = 0x0008 (DIN = 0xA900, 0xA808) and ALM_MAG_S = 0x533 (DIN = 0xA705, 0xA633) to disable all three inertial alarms and configure the system alarm active when TEMP_OUT is <0°C.

STATIC ALARMS

The static alarm setting enables the ADIS16210 to compare the data source (ALM_CTRL[6:4]) with the corresponding values

in the ALM_MAG_x registers (see Table 45, Table 46, and Table 47) using the trigger direction/polarity settings in ALM_CTRL[10:8]. For example, if ALM_CTRL[10] = 0, ALM_CTRL[6] = 1, and ALM_MAG_Z = 0x2000, then Alarm Z becomes active when ZINCL_OUT is less than 0x2000, or 45°.

DYNAMIC ALARMS

The dynamic alarm setting monitors the data selection for a rate-of-change comparison. The rate-of-change comparison is represented by the magnitude in the ALM_MAG_x registers (see Table 45, Table 46, and Table 47), divided by the time in the ALM_SMPL_x registers (see Table 49, Table 50, Table 51).

For example, if ALM_CTRL[9] = 1, ALM_CTRL[5] = 0, ALM_MAG_Y = 0x4000, and ALM_SMPL_Y = 0x0064, then Alarm Y (DIAG_STAT[9]) becomes active when YACCL_OUT changes by more than +1 g over 100 samples. The AVG_CNT register (Table 22) establishes the time for each sample.

Table 45. ALM_MAG_X (Base Address = 0x20), Read/Write

Bits	Description (Default = 0x0000)
[15:0]	Same data format as ZACCL_OUT or ZINCL_OUT, according to the setting in ALM_CTRL[4]

Table 46. ALM_MAG_Y (Base Address = 0x22), Read/Write

Bits	Description (Default = 0x0000)
[15:0]	Same data format as ZACCL_OUT or ZINCL_OUT, according to the setting in ALM_CTRL[5]

Table 47. ALM_MAG_Z (Base Address = 0x24), Read/Write

Bits	Description (Default = 0x0000)
[15:0]	Same data format as ZACCL_OUT or ZINCL_OUT, according to the setting in ALM_CTRL[6]

Table 48. ALM_MAG_S (Base Address = 0x26), Read/Write

Bits	Description (Default = 0x0000)
[15:0]	Same data format as SUPPLY_OUT or TEMP_OUT, according to the setting in ALM_CTRL[7]

Table 49. ALM_SMPL_X (Base Address = 0x28), Read/Write

Bits	Description (Default = 0x0001)
[15:8]	Not used
[7:0]	Binary, number of samples

Table 50. ALM_SMPL_Y (Base Address = 0x2A), Read/Write

Bits	Description (Default = 0x0001)
[15:8]	Not used
[7:0]	Binary, number of samples

Table 51. ALM_SMPL_Z (Base Address = 0x2C), Read/Write

Bits	Description (Default = 0x0001)
[15:8]	Not used
[7:0]	Binary, number of samples

ALARM REPORTING

See DIAG_STAT[11:8] (see Table 42) for alarm flags, which equal 1 when an alarm condition is detected. DIO_CTRL (see Table 36) offers settings that configure DIO1 or DIO2 as an alarm indicator signal.

APPLICATIONS INFORMATION

MATING CONNECTOR

The mating connector for the [ADIS16210](#), J2, is the AVX® 04-6288-015-000-846. Figure 23 provides a close-up view of this connector, which clamps down on the flex cable to press its metal pads onto the metal pads inside of the mating connector.

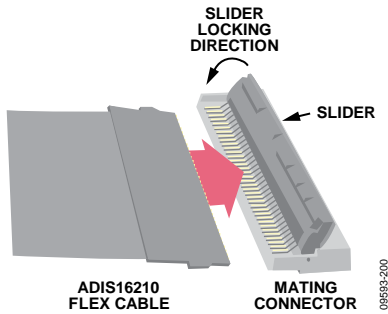

Figure 23. Mating Connector Detail

BREAKOUT BOARD

The [ADIS16ACL1/PCBZ](#) breakout board provides a convenient means for connecting the [ADIS16210](#) to an embedded processor, using a standard ribbon cable. This printed circuit board (PCB) provides four mounting holes (one in each corner), which provide clearance for 4-40 machine screws.

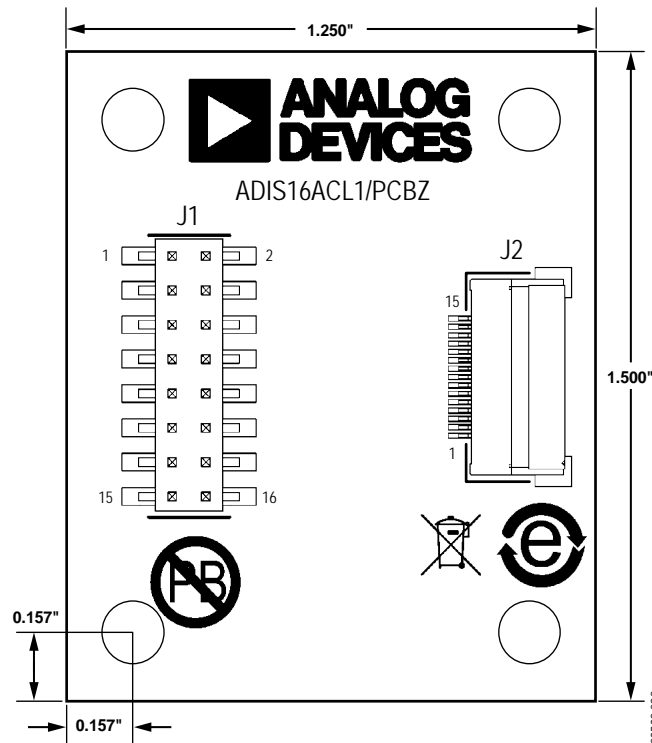

Figure 24. [ADIS16ACL1/PCBZ](#) Top Level View/Dimensions

J1 is a 16-pin connector, which mates with 2 mm pitch, IDC ribbon cables, such as the TCSD series from Samtec®. The LEDs (D1 and D2) are not populated; however, the pads are available to install to provide a visual representation of the DIO1 and DIO2 signals. The pads accommodate VCC™ CMD28-21VRC/TR8, which works well when R1 and R2 are approximately 400 Ω (0603 pad sizes).

PC-BASED EVALUATION TOOLS

The [ADIS16ACL1/PCBZ](#) provides a simple way to connect the [ADIS16210](#) to the [EVAL-ADIS2](#) evaluation system, which provides a PC-based method for evaluation of basic function and performance. For more information, visit the [EVAL-ADIS2 Evaluation System](#) page on the Analog Devices, Inc., website.

X-RAY SENSITIVITY

Exposure to high dose rate X-rays, such as those in production systems that inspect solder joints in electronic assemblies, may affect accelerometer bias errors. For optimal performance, avoid exposing the [ADIS16210](#) to this type of inspection.

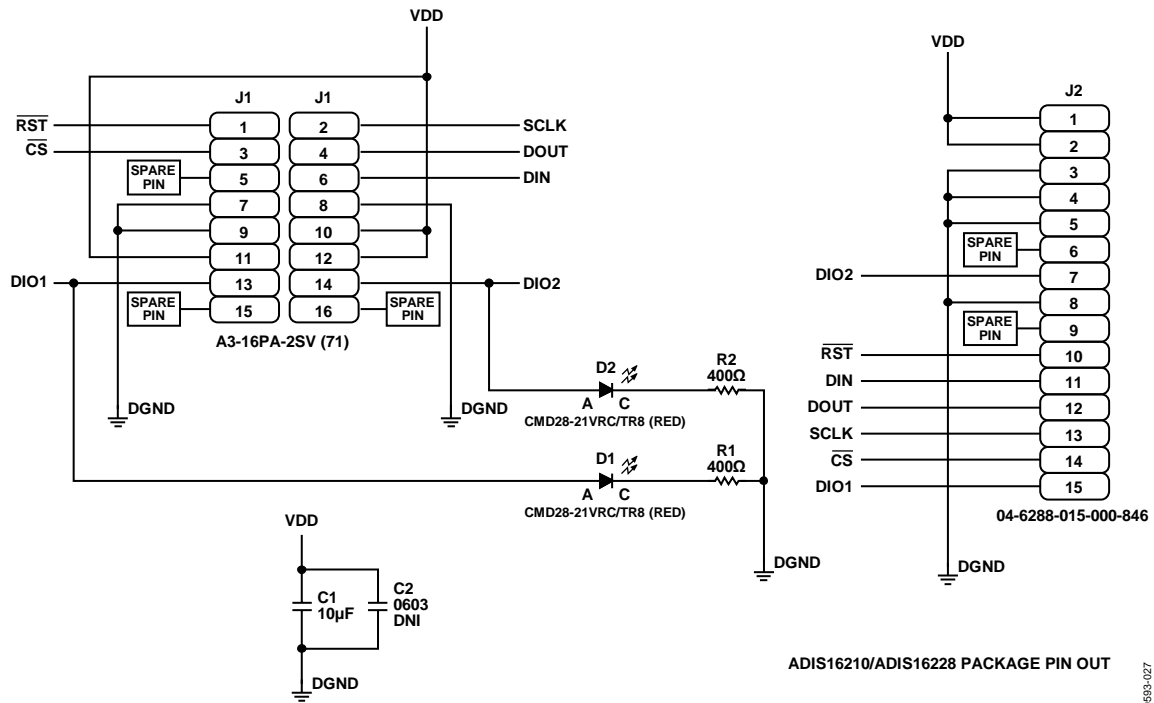

Figure 25. ADIS16ACL1/PCBZ Electrical Schematic

08593-027

OUTLINE DIMENSIONS

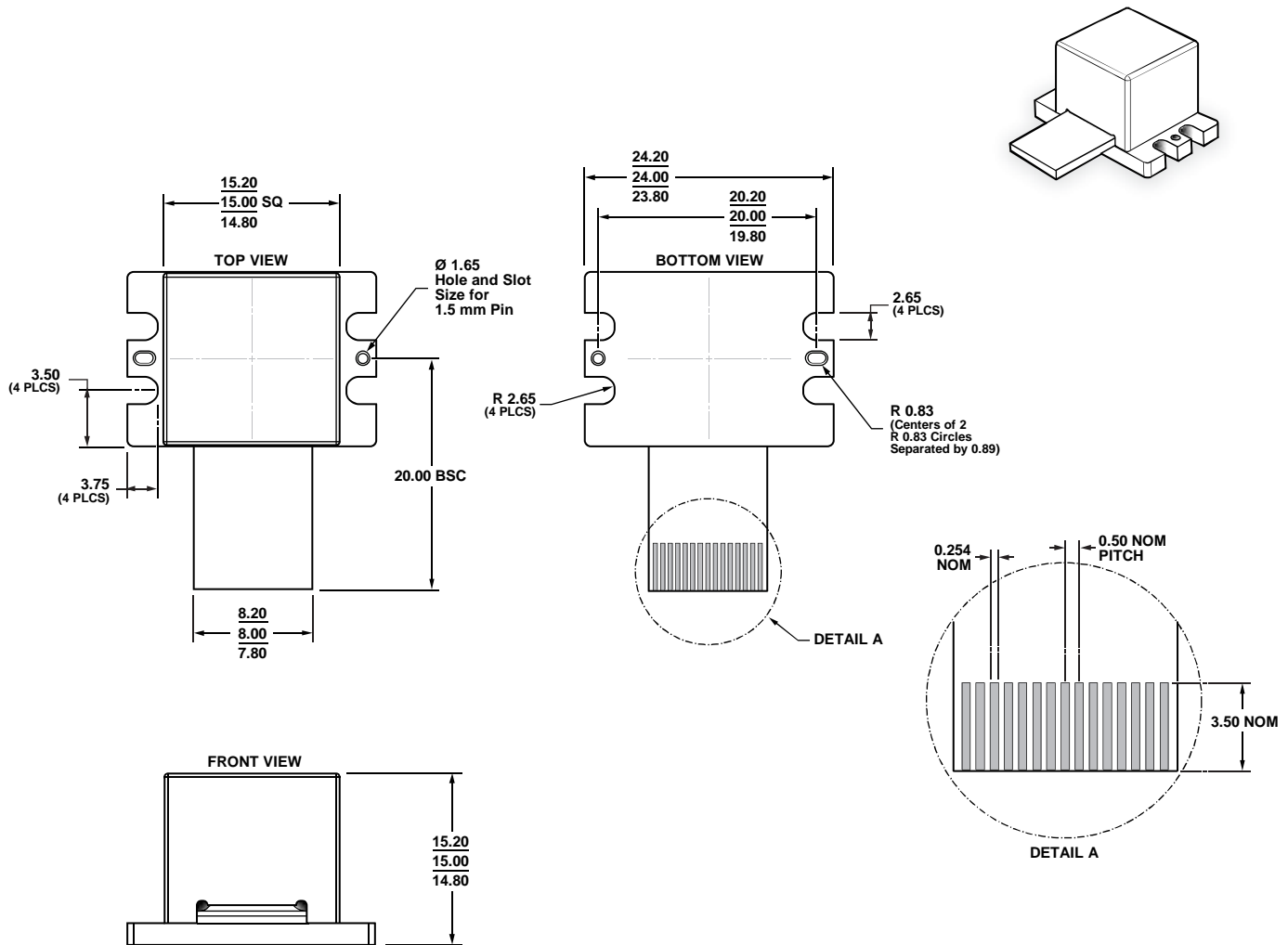

Figure 26. 15-Lead Module with Connector Interface (ML-15-1)
Dimensions shown in millimeters

04-27-2011-A

ORDERING GUIDE

Model ¹	Temperature Range	Package Description	Package Option
ADIS16210CMLZ	-40°C to +125°C	15-Lead Module with Connector Interface	ML-15-1
ADIS16ACL1/PCBZ		Breakout Board	
EVAL-ADIS2Z		Evaluation System	

¹ Z = RoHS Compliant Part.

Looking for pricing, stock, or lifecycle information?

Click below to explore more details on WIN SOURCE:

- ⊖ [View ADIS16210CMLZ on WIN SOURCE](#)
- ⊖ [Analog Devices Inc. Information](#)

Optimize Your Supply Chain with WIN SOURCE Solutions

- ✓ Global Sourcing Solution
- ✓ Obsolete Management
- ✓ Cost Control Management
- ✓ Shortage Management
- ✓ Alternative Solution
- ✓ Excess Inventory Management