



**THE DATASHEET OF  
MC100LVEP210FA**



# 2.5 V / 3.3 V 1:5 Dual Differential ECL/PECL/HSTL Clock Driver

## MC100LVEP210

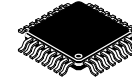

LQFP-32  
FA SUFFIX  
CASE 561AB

### Description

The MC100LVEP210 is a low skew 1-to-5 dual differential driver, designed with clock distribution in mind. The ECL/PECL input signals can be either differential or single-ended if the  $V_{BB}$  output is used. The signal is fanned out to 5 identical differential outputs. HSTL inputs can be used when the EP210 is operating in PECL mode.

The LVEP210 specifically guarantees low output-to-output skew. Optimal design, layout, and processing minimize skew within a device and from device to device.

To ensure the tight skew specification is realized, both sides of the differential output need to be terminated identically into  $50\ \Omega$  even if only one output is being used. If an output pair is unused, both outputs may be left open (unterminated) without affecting skew.

The MC100LVEP210, as with most other ECL devices, can be operated from a positive  $V_{CC}$  supply in PECL mode. This allows the LVEP210 to be used for high performance clock distribution in +3.3 V or +2.5 V systems. Single-ended CLK input operation is limited to a  $V_{CC} \geq 3.0\ \text{V}$  in PECL mode, or  $V_{EE} \leq -3.0\ \text{V}$  in ECL mode.

Designers can take advantage of the LVEP210's performance to distribute low skew clocks across the backplane or the board. In a PECL environment, series or Thevenin line terminations are typically used as they require no additional power supplies. For more information on using PECL, designers should refer to Application Note [AN1406/D](#).

### Features

- 85 ps Typical Device-to-Device Skew
- 20 ps Typical Output-to-Output Skew
- $V_{BB}$  Output
- Jitter Less than 1 ps RMS
- 350 ps Typical Propagation Delay
- Maximum Frequency > 3 GHz Typical
- The 100 Series Contains Temperature Compensation
- PECL and HSTL Mode Operating Range:  $V_{CC} = 2.375\ \text{V}$  to  $3.8\ \text{V}$  with  $V_{EE} = 0\ \text{V}$
- NECL Mode Operating Range:  $V_{CC} = 0\ \text{V}$  with  $V_{EE} = -2.375\ \text{V}$  to  $-3.8\ \text{V}$
- Open Input Default State
- LVDS Input Compatible
- Fully Compatible with MC100EP210
- These are Pb-Free Devices

### MARKING DIAGRAM

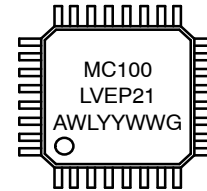

A	= Assembly Location
WL	= Wafer Lot
YY	= Year
WW	= Work Week
G or ■	= Pb-Free Package

(Note: Microdot may be in either location)

\*For additional marking information, refer to Application Note [AND8002/D](#).

### ORDERING INFORMATION

See detailed ordering and shipping information in the package dimensions section on page 7 of this data sheet.

# MC100LVEP210

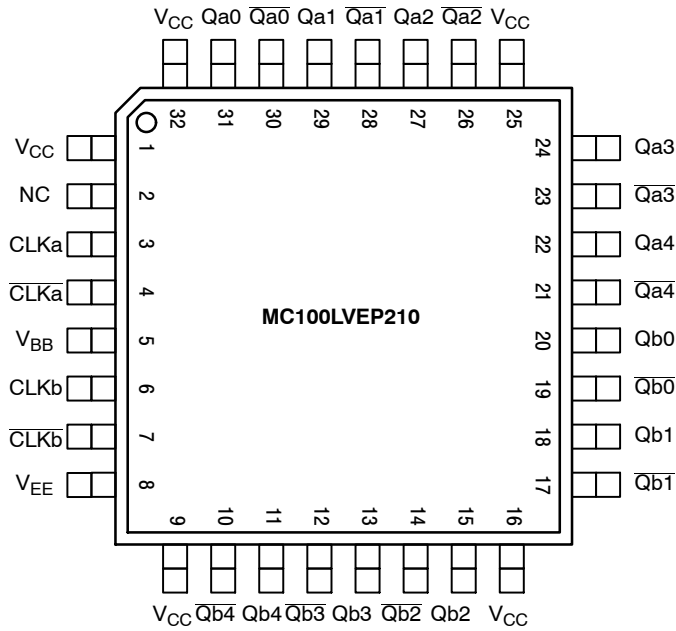

Warning: All  $V_{CC}$  and  $V_{EE}$  pins must be externally connected to Power Supply to guarantee proper operation.

Figure 1. LQFP-32 Pinout (Top View)

Table 1. PIN DESCRIPTION

PIN	FUNCTION
CLKn*, $\overline{CLKn}$ **	ECL/PECL/HSTL CLK Inputs
Qn0:4, $\overline{Qn0:4}$	ECL/PECL Outputs
$V_{BB}$	Reference Voltage Output
$V_{CC}$	Positive Supply
$V_{EE}$	Negative Supply

\* Pins will default LOW when left open.

\*\* Pins will default to  $V_{CC}/2$  when left open.

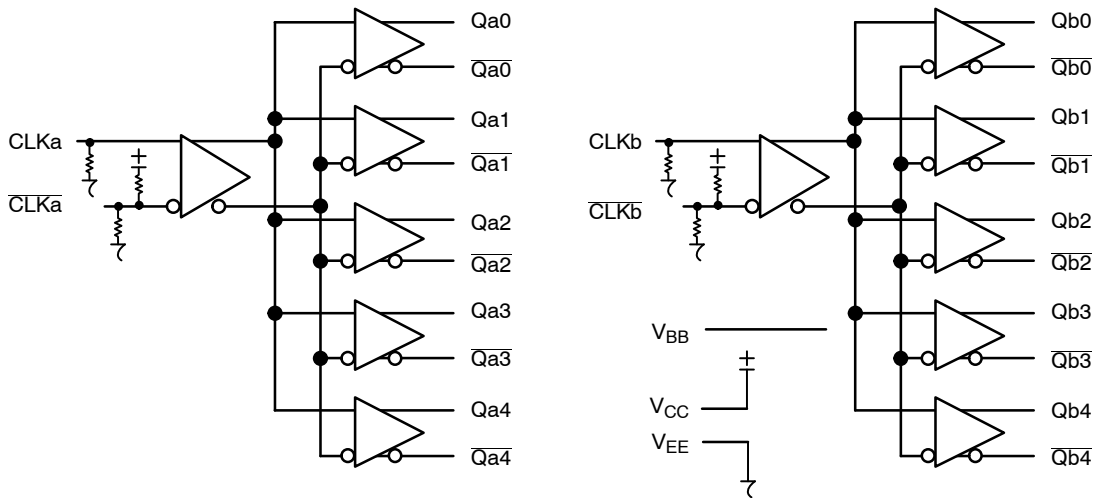

Figure 2. Logic Diagram

# MC100LVEP210

**Table 2. ATTRIBUTES**

Characteristics	Value
Internal Input Pulldown Resistor	75 k $\Omega$
Internal Input Pull-up Resistor	37.5 k $\Omega$
ESD Protection Human Body Model Machine Model Charged Device Model	> 2 kV > 100 V > 2 kV
Moisture Sensitivity (Note 1)	Pb-Free Pkg Level 2
	LQFP-32
Flammability Rating Oxygen Index: 28 to 34	UL 94 V-0 @ 0.125 in
Transistor Count	461 Devices
Meets or exceeds JEDEC Spec EIA/JESD78 IC Latchup Test	

1. For additional information, see Application Note [AND8003/D](#).

**Table 3. MAXIMUM RATINGS**

Symbol	Parameter	Condition 1	Condition 2	Rating	Unit
V <sub>CC</sub>	PECL Mode Power Supply	V <sub>EE</sub> = 0 V		6	V
V <sub>EE</sub>	NECL Mode Power Supply	V <sub>CC</sub> = 0 V		-6	V
V <sub>I</sub>	PECL Mode Input Voltage NECL Mode Input Voltage	V <sub>EE</sub> = 0 V V <sub>CC</sub> = 0 V	V <sub>I</sub> $\leq$ V <sub>CC</sub> V <sub>I</sub> $\geq$ V <sub>EE</sub>	6 -6	V V
I <sub>out</sub>	Output Current	Continuous Surge		50 100	mA mA
I <sub>BB</sub>	V <sub>BB</sub> Sink/Source			$\pm$ 0.5	mA
T <sub>A</sub>	Operating Temperature Range			-40 to +85	$^{\circ}$ C
T <sub>stg</sub>	Storage Temperature Range			-65 to +150	$^{\circ}$ C
$\theta_{JA}$	Thermal Resistance (Junction-to-Ambient)	0 lfpm 500 lfpm	LQFP-32 LQFP-32	80 55	$^{\circ}$ C/W $^{\circ}$ C/W
$\theta_{JC}$	Thermal Resistance (Junction-to-Case)	Standard Board	LQFP-32	12 to 17	$^{\circ}$ C/W
T <sub>sol</sub>	Wave Solder Pb Pb-Free	<2 to 3 sec @ 248 $^{\circ}$ C <2 to 3 sec @ 260 $^{\circ}$ C		265 265	$^{\circ}$ C

Stresses exceeding those listed in the Maximum Ratings table may damage the device. If any of these limits are exceeded, device functionality should not be assumed, damage may occur and reliability may be affected.

# MC100LVEP210

**Table 4. PECL DC CHARACTERISTICS**  $V_{CC} = 2.5\text{ V}$ ;  $V_{EE} = 0\text{ V}$  (Note 2)

Symbol	Characteristic	-40°C			25°C			85°C			Unit
		Min	Typ	Max	Min	Typ	Max	Min	Typ	Max	
$I_{EE}$	Power Supply Current	55	70	90	55	70	90	55	70	90	mA
$V_{OH}$	Output HIGH Voltage (Note 3)	1355	1480	1605	1355	1480	1605	1355	1480	1605	mV
$V_{OL}$	Output LOW Voltage (Note 3)	505	680	900	505	680	900	505	680	900	mV
$V_{IHCMR}$	Input HIGH Voltage Common Mode Range (Differential Configuration) (Note 4)	1.2		2.5	1.2		2.5	1.2		2.5	V
$V_{IL}$	Input LOW Voltage (Single-Ended)	505		900	505		900	505		900	mV
$I_{IH}$	Input HIGH Current			150			150			150	$\mu\text{A}$
$I_{IL}$	Input LOW Current	CLK CLK	0.5 -150		0.5 -150			0.5 -150			$\mu\text{A}$

NOTE: Device will meet the specifications after thermal equilibrium has been established when mounted in a test socket or printed circuit board with maintained transverse airflow greater than 500 lpm.

- Input and output parameters vary 1:1 with  $V_{CC}$ .  $V_{EE}$  can vary + 0.125 V to -1.3 V.
- All loading with 50  $\Omega$  to  $V_{EE}$ .
- $V_{IHCMR}$  min varies 1:1 with  $V_{EE}$ ,  $V_{IHCMR}$  max varies 1:1 with  $V_{CC}$ . The  $V_{IHCMR}$  range is referenced to the most positive side of the differential input signal.

**Table 5. PECL DC CHARACTERISTICS**  $V_{CC} = 3.3\text{ V}$ ;  $V_{EE} = 0\text{ V}$  (Note 5)

Symbol	Characteristic	-40°C			25°C			85°C			Unit
		Min	Typ	Max	Min	Typ	Max	Min	Typ	Max	
$I_{EE}$	Power Supply Current	55	70	90	55	70	90	55	70	90	mA
$V_{OH}$	Output HIGH Voltage (Note 6)	2155	2280	2405	2155	2280	2405	2155	2280	2405	mV
$V_{OL}$	Output LOW Voltage (Note 6)	1305	1480	1700	1305	1480	1700	1305	1480	1700	mV
$V_{IH}$	Input HIGH Voltage (Single-Ended)	2135		2420	2135		2420	2135		2420	mV
$V_{IL}$	Input LOW Voltage (Single-Ended)	1305		1700	1305		1700	1305		1700	mV
$V_{BB}$	Output Reference Voltage (Note 7)	1775	1875	1975	1775	1875	1975	1775	1875	1975	mV
$V_{IHCMR}$	Input HIGH Voltage Common Mode Range (Differential Configuration) (Note 8)	1.2		3.3	1.2		3.3	1.2		3.3	V
$I_{IH}$	Input HIGH Current			150			150			150	$\mu\text{A}$
$I_{IL}$	Input LOW Current	CLK CLK	0.5 -150		0.5 -150			0.5 -150			$\mu\text{A}$

NOTE: Device will meet the specifications after thermal equilibrium has been established when mounted in a test socket or printed circuit board with maintained transverse airflow greater than 500 lpm.

- Input and output parameters vary 1:1 with  $V_{CC}$ .  $V_{EE}$  can vary + 0.925 V to -0.5 V.
- All loading with 50  $\Omega$  to  $V_{CC} - 2.0\text{ V}$ .
- Single-ended input operation is limited  $V_{CC} \geq 3.0\text{ V}$  in PECL mode.
- $V_{IHCMR}$  min varies 1:1 with  $V_{EE}$ ,  $V_{IHCMR}$  max varies 1:1 with  $V_{CC}$ . The  $V_{IHCMR}$  range is referenced to the most positive side of the differential input signal.

# MC100LVEP210

**Table 6. NECL DC CHARACTERISTICS**  $V_{CC} = 0\text{ V}$ ,  $V_{EE} = -2.375\text{ V to }-3.8\text{ V}$  (Note 9)

Symbol	Characteristic	-40°C			25°C			85°C			Unit
		Min	Typ	Max	Min	Typ	Max	Min	Typ	Max	
$I_{EE}$	Power Supply Current	55	70	90	55	70	90	55	70	90	mA
$V_{OH}$	Output HIGH Voltage (Note 10)	-1145	-1020	-895	-1145	-1020	-895	-1145	-1020	-895	mV
$V_{OL}$	Output LOW Voltage (Note 10)	-1995	-1820	-1600	-1995	-1820	-1600	-1995	-1820	-1600	mV
$V_{IH}$	Input HIGH Voltage (Single-Ended)	-1165		-880	-1165		-880	-1165		-880	mV
$V_{IL}$	Input LOW Voltage (Single-Ended)	-1995		-1600	-1995		-1600	-1995		-1600	mV
$V_{BB}$	Output Reference Voltage (Note 11)	-1525	-1425	-1325	-1525	-1425	-1325	-1525	-1425	-1325	mV
$V_{IHCMR}$	Input HIGH Voltage Common Mode Range (Differential Configuration) (Note 12)	$V_{EE} + 1.2$		0.0	$V_{EE} + 1.2$		0.0	$V_{EE} + 1.2$		0.0	V
$I_{IH}$	Input HIGH Current			150			150			150	$\mu\text{A}$
$I_{IL}$	Input LOW Current	CLK CLK	0.5 -150		0.5 -150			0.5 -150		150	$\mu\text{A}$

NOTE: Device will meet the specifications after thermal equilibrium has been established when mounted in a test socket or printed circuit board with maintained transverse airflow greater than 500 lfm.

9. Input and output parameters vary 1:1 with  $V_{CC}$ .

10. All loading with  $50\ \Omega$  to  $V_{CC} - 2.0\text{ V}$ .

11. Single-ended input operation is limited  $V_{EE} \leq -3.0\text{ V}$  in NECL mode.

12.  $V_{IHCMR}$  min varies 1:1 with  $V_{EE}$ .  $V_{IHCMR}$  max varies 1:1 with  $V_{CC}$ . The  $V_{IHCMR}$  range is referenced to the most positive side of the differential input signal.

**Table 7. HSTL DC CHARACTERISTICS**  $V_{CC} = 2.375\text{ to }3.8\text{ V}$ ,  $V_{EE} = 0\text{ V}$

Symbol	Characteristic	-40°C			25°C			85°C			Unit
		Min	Typ	Max	Min	Typ	Max	Min	Typ	Max	
$V_{IH}$	Input HIGH Voltage	1200			1200			1200			mV
$V_{IL}$	Input LOW Voltage			400			400			400	mV
$V_{CM}$	Input Crossover Voltage	680		900	680		900	680		900	mV
$I_{CC}$	Power Supply Current (Outputs Open)	55	70	90	55	70	90	55	70	90	mA

NOTE: Device will meet the specifications after thermal equilibrium has been established when mounted in a test socket or printed circuit board with maintained transverse airflow greater than 500 lfm.

# MC100LVEP210

**Table 8. AC CHARACTERISTICS**  $V_{CC} = 0\text{ V}$ ;  $V_{EE} = -2.375\text{ to }-3.8\text{ V}$  or  $V_{CC} = 2.375\text{ to }3.8\text{ V}$ ;  $V_{EE} = 0\text{ V}$  (Note 13)

Symbol	Characteristic	-40°C			25°C			85°C			Unit
		Min	Typ	Max	Min	Typ	Max	Min	Typ	Max	
$f_{\text{maxPECL/HSTL}}$	Maximum Frequency (Figure 3)		3			3			3		GHz
$t_{\text{PLH}}/t_{\text{PHL}}$	Propagation Delay @ 2.5 V Propagation Delay @ 3.3 V	220 220	300 300	380 380	270 270	350 350	430 430	300 330	400 410	500 490	ps
$t_{\text{skew}}$	Within-Device Skew (Note 14) Device-to-Device Skew (Note 15)		20 85	25 160		20 85	25 160		20 85	35 160	ps
$t_{\text{JITTER}}$	CLOCK Random Jitter (RMS) @ $\leq 0.5\text{ GHz}$ @ $\leq 1.0\text{ GHz}$ @ $\leq 1.5\text{ GHz}$ @ $\leq 2.0\text{ GHz}$ @ $\leq 2.5\text{ GHz}$ @ $\leq 3.0\text{ GHz}$		0.184 0.190 0.178 0.196 0.239 0.336	0.3 0.3 0.3 0.3 0.4 0.5		0.207 0.200 0.197 0.233 0.301 0.422	0.3 0.3 0.3 0.4 0.4 0.5		0.271 0.252 0.259 0.308 0.399 0.572	0.4 0.4 0.4 0.5 0.5 0.9	ps
$V_{\text{PP}}$	Minimum Input Swing	150	800	1200	150	800	1200	150	800	1200	mV
$t_{\text{r}}/t_{\text{f}}$	Output Rise/Fall Time (20%–80%)	100	170	250	120	190	270	150	280	350	ps

NOTE: Device will meet the specifications after thermal equilibrium has been established when mounted in a test socket or printed circuit board with maintained transverse airflow greater than 500 lpm.

13. Measured with 750 mV source, 50% duty cycle clock source. All loading with  $50\ \Omega$  to  $V_{CC} - 2.0\text{ V}$ .

14. Skew is measured between outputs under identical transitions of similar paths through a device.

15. Device-to-Device skew for identical transitions at identical  $V_{CC}$  levels.

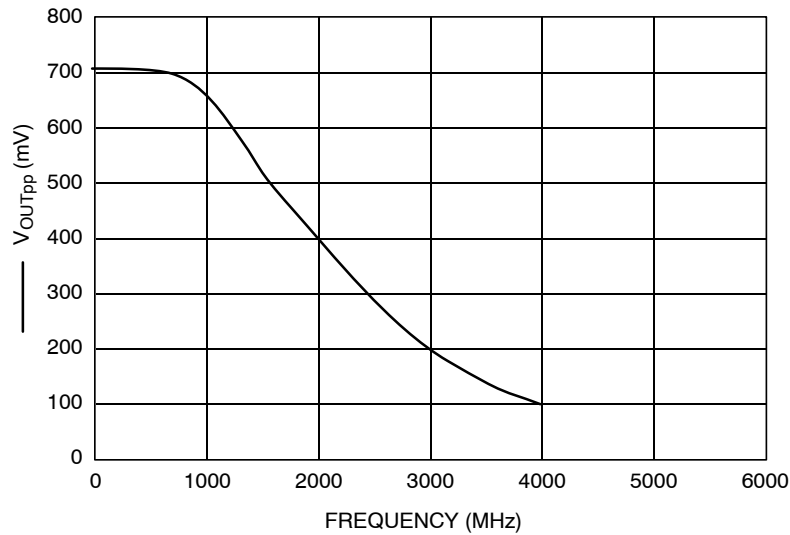

**Figure 3.  $F_{\text{max}}$  Typical**

## MC100LVEP210

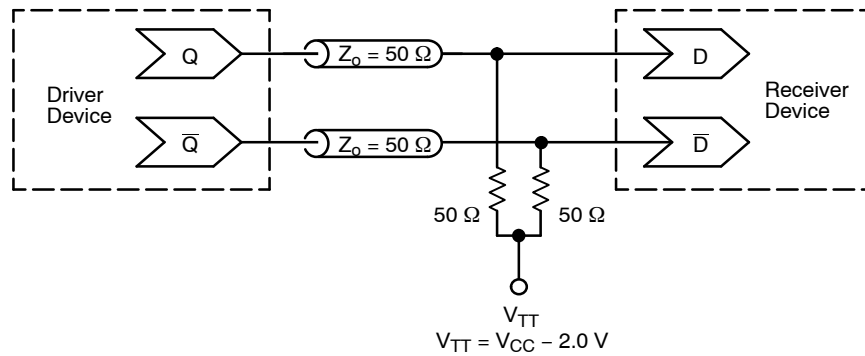

**Figure 4. Typical Termination for Output Driver and Device Evaluation**  
(See Application Note [AND8020/D](#) – Termination of ECL Logic Devices.)

### ORDERING INFORMATION

Device	Package	Shipping <sup>†</sup>
MC100LVEP210FAG	LQFP (Pb-Free)	250 Units / Tray
MC100LVEP210FARG	LQFP (Pb-Free)	2,000 / Tape & Reel

<sup>†</sup>For information on tape and reel specifications, including part orientation and tape sizes, please refer to our Tape and Reel Packaging Specifications Brochure, [BRD8011/D](#).

### Resource Reference of Application Notes

- AN1405/D** – ECL Clock Distribution Techniques
- AN1406/D** – Designing with PECL (ECL at +5.0 V)
- AN1503/D** – ECLinPS™ I/O SPICE Modeling Kit
- AN1504/D** – Metastability and the ECLinPS Family
- AN1568/D** – Interfacing Between LVDS and ECL
- AN1672/D** – The ECL Translator Guide
- AND8001/D** – Odd Number Counters Design
- AND8002/D** – Marking and Date Codes
- AND8020/D** – Termination of ECL Logic Devices
- AND8066/D** – Interfacing with ECLinPS
- AND8090/D** – AC Characteristics of ECL Devices

ECLinPS is a trademarks of Semiconductor Components Industries, LLC dba "onsemi" or its affiliates and/or subsidiaries in the United States and/or other countries.

**MECHANICAL CASE OUTLINE**  
**PACKAGE DIMENSIONS**

ON Semiconductor®



**LQFP-32, 7x7**  
**CASE 561AB-01**  
**ISSUE O**

DATE 19 JUN 2008

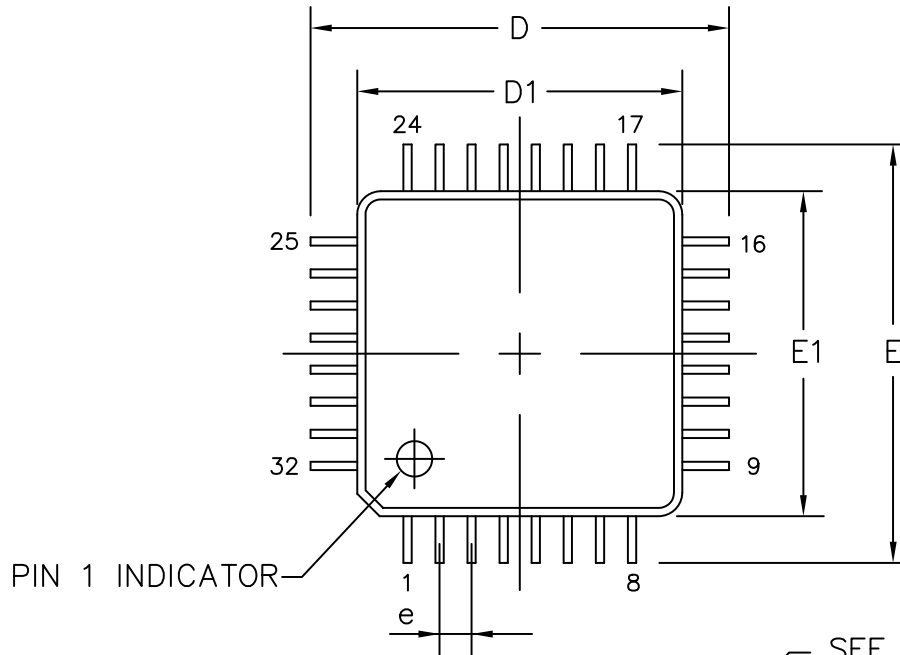

SYMBOL	MIN	NOM	MAX
A	—	—	1.60
A1	0.05	—	0.15
A2	1.35	1.40	1.45
B	0.30	0.37	0.45
B1	0.30	0.35	0.40
C	0.09	—	0.20
C1	0.09	—	0.16
D	9.00 BSC		
D1	7.00 BSC		
E	9.00 BSC		
E1	7.00 BSC		
e	0.80 BSC		
L	0.45	0.60	0.75
L1	1.00		
R1	0.08	—	0.20
$\alpha^\circ$	11	—	13
$\beta^\circ$	0	—	7
$\gamma^\circ$	0	—	—

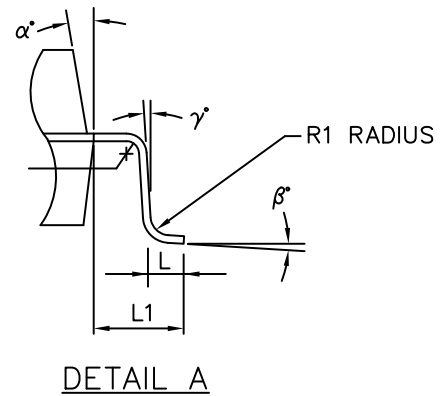
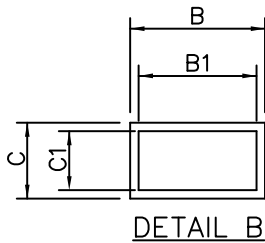
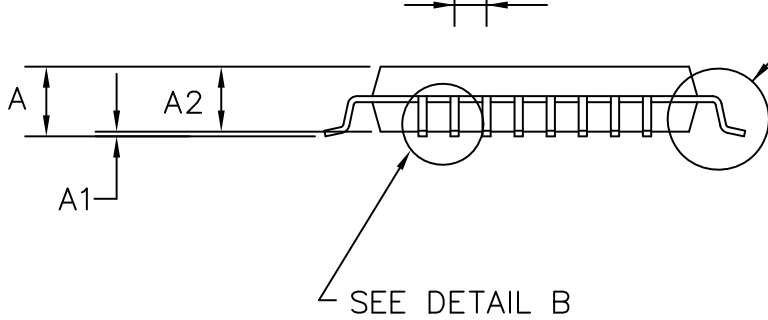

ALL DIMENSIONS IN MM

<b>DOCUMENT NUMBER:</b>	<b>98AON30893E</b>	Electronic versions are uncontrolled except when accessed directly from the Document Repository. Printed versions are uncontrolled except when stamped "CONTROLLED COPY" in red.
<b>DESCRIPTION:</b>	<b>32 LEAD LQFP, 7X7</b>	<b>PAGE 1 OF 1</b>

ON Semiconductor and are trademarks of Semiconductor Components Industries, LLC dba ON Semiconductor or its subsidiaries in the United States and/or other countries. ON Semiconductor reserves the right to make changes without further notice to any products herein. ON Semiconductor makes no warranty, representation or guarantee regarding the suitability of its products for any particular purpose, nor does ON Semiconductor assume any liability arising out of the application or use of any product or circuit, and specifically disclaims any and all liability, including without limitation special, consequential or incidental damages. ON Semiconductor does not convey any license under its patent rights nor the rights of others.

**onsemi**, **Onsemi**, and other names, marks, and brands are registered and/or common law trademarks of Semiconductor Components Industries, LLC dba "**onsemi**" or its affiliates and/or subsidiaries in the United States and/or other countries. **onsemi** owns the rights to a number of patents, trademarks, copyrights, trade secrets, and other intellectual property. A listing of **onsemi**'s product/patent coverage may be accessed at [www.onsemi.com/site/pdf/Patent-Marking.pdf](http://www.onsemi.com/site/pdf/Patent-Marking.pdf). **onsemi** reserves the right to make changes at any time to any products or information herein, without notice. The information herein is provided "as-is" and **onsemi** makes no warranty, representation or guarantee regarding the accuracy of the information, product features, availability, functionality, or suitability of its products for any particular purpose, nor does **onsemi** assume any liability arising out of the application or use of any product or circuit, and specifically disclaims any and all liability, including without limitation special, consequential or incidental damages. Buyer is responsible for its products and applications using **onsemi** products, including compliance with all laws, regulations and safety requirements or standards, regardless of any support or applications information provided by **onsemi**. "Typical" parameters which may be provided in **onsemi** data sheets and/or specifications can and do vary in different applications and actual performance may vary over time. All operating parameters, including "Typicals" must be validated for each customer application by customer's technical experts. **onsemi** does not convey any license under any of its intellectual property rights nor the rights of others. **onsemi** products are not designed, intended, or authorized for use as a critical component in life support systems or any FDA Class 3 medical devices or medical devices with a same or similar classification in a foreign jurisdiction or any devices intended for implantation in the human body. Should Buyer purchase or use **onsemi** products for any such unintended or unauthorized application, Buyer shall indemnify and hold **onsemi** and its officers, employees, subsidiaries, affiliates, and distributors harmless against all claims, costs, damages, and expenses, and reasonable attorney fees arising out of, directly or indirectly, any claim of personal injury or death associated with such unintended or unauthorized use, even if such claim alleges that **onsemi** was negligent regarding the design or manufacture of the part. **onsemi** is an Equal Opportunity/Affirmative Action Employer. This literature is subject to all applicable copyright laws and is not for resale in any manner.

## ADDITIONAL INFORMATION

### TECHNICAL PUBLICATIONS:

Technical Library: [www.onsemi.com/design/resources/technical-documentation](http://www.onsemi.com/design/resources/technical-documentation)  
onsemi Website: [www.onsemi.com](http://www.onsemi.com)

### ONLINE SUPPORT: [www.onsemi.com/support](http://www.onsemi.com/support)

For additional information, please contact your local Sales Representative at [www.onsemi.com/support/sales](http://www.onsemi.com/support/sales)



## Looking for pricing, stock, or lifecycle information?

Click below to explore more details on WIN SOURCE:

- ⊖ [View MC100LVEP210FA on WIN SOURCE](#)
- ⊖ [ON Semiconductor Information](#)

## Optimize Your Supply Chain with WIN SOURCE Solutions

- ✓ Global Sourcing Solution
- ✓ Obsolete Management
- ✓ Cost Control Management
- ✓ Shortage Management
- ✓ Alternative Solution
- ✓ Excess Inventory Management