



**THE DATASHEET OF
BQ27542DRZR-G1**



bq27542-G1 Single Cell Li-Ion Battery Fuel Gauge for Battery Pack Integration

1 Features

- Battery Fuel Gauge for 1-Series (1sXp) Li-Ion Applications up to 14,500-mAh Capacity
- Microcontroller Peripheral Provides:
 - Accurate Battery Fuel Gauging Supports up to 14,500 mAh
 - Internal or External Temperature Sensor for Battery Temperature Reporting
 - SHA-1/HMAC Authentication
 - Lifetime Data Logging
 - 64 Bytes of Non-Volatile Scratch Pad FLASH
- Battery Fuel Gauging Based on Patented Impedance Track™ Technology
 - Models Battery Discharge Curve for Accurate Time-To-Empty Predictions
 - Automatically Adjusts for Battery Aging, Battery Self-Discharge, and Temperature/Rate Inefficiencies
 - Low-Value Sense Resistor (5 mΩ to 20 mΩ)
- Advanced Fuel Gauging Features
 - Internal Short Detection
 - Tab Disconnection Detection
- HDQ and I²C Interface Formats for Communication with Host System
- Small 12-pin 2.50 mm × 4.00 mm SON Package
- Complies with Battery Trip Point (BTP) Requirements

2 Applications

- Smartphones
- Tablets
- Digital Still and Video Cameras
- Handheld Terminals
- MP3 or Multimedia Players

3 Description

The Texas Instruments bq27542-G1 Li-Ion battery fuel gauge is a microcontroller peripheral that provides fuel gauging for single-cell Li-Ion battery packs. The device requires little system microcontroller firmware development for accurate battery fuel gauging. The fuel gauge resides within the battery pack or on the main board of the system with an embedded battery (non-removable).

The fuel gauge uses the patented Impedance Track™ algorithm for fuel gauging, and provides information such as remaining battery capacity (mAh), state-of-charge (%), run-time to empty (minimum), battery voltage (mV), and temperature (°C). It also provides detections for internal short or tab disconnection events.

The fuel gauge also features integrated support for secure battery pack authentication, using the SHA-1/HMAC authentication algorithm.

Device Information⁽¹⁾

PART NUMBER	PACKAGE	BODY SIZE (NOM)
bq27542-G1	SON (12)	2.50 mm x 4.00 mm

(1) For all available packages, see the orderable addendum at the end of the data sheet.

4 Simplified Schematic

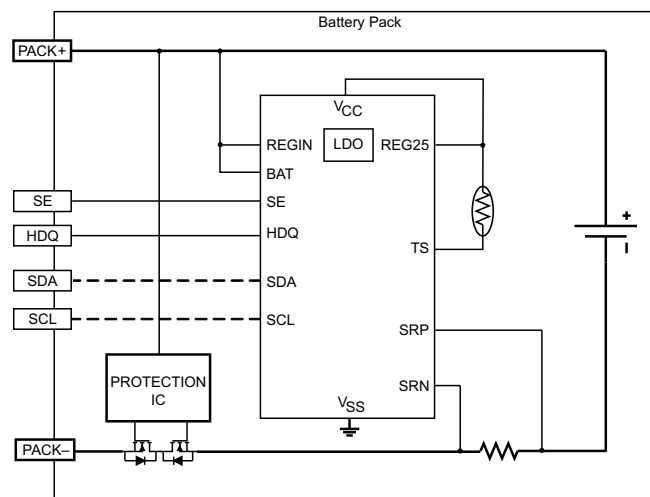

Table of Contents

1	Features	1	9	Detailed Description	10
2	Applications	1	9.1	Overview	10
3	Description	1	9.2	Functional Block Diagram	11
4	Simplified Schematic	1	9.3	Feature Description	12
5	Revision History	2	9.4	Device Functional Modes	14
6	Device Comparison Table	3	9.5	Programming	16
7	Pin Configurations and Functions	3	9.6	Power Control	17
8	Specifications	4	9.7	Autocalibration	18
8.1	Absolute Maximum Ratings	4	9.8	Communications	18
8.2	ESD Ratings	4	10	Application and Implementation	22
8.3	Recommended Operating Conditions	4	10.1	Application Information	22
8.4	Thermal Information	5	10.2	Typical Application	22
8.5	Electrical Characteristics: Power-On Reset	5	10.3	Application Curves	27
8.6	2.5-V LDO Regulator	5	11	Power Supply Recommendations	28
8.7	Internal Temperature Sensor Characteristics	5	12	Layout	28
8.8	Internal Clock Oscillators	5	12.1	Layout Guidelines	28
8.9	Integrating ADC (Coulomb Counter) Characteristics	6	12.2	Layout Example	29
8.10	ADC (Temperature and Cell Voltage) Characteristics	6	13	Device and Documentation Support	30
8.11	Data Flash Memory Characteristics	6	13.1	Documentation Support	30
8.12	Timing Requirements	6	13.2	Community Resources	30
8.13	Timing Requirements: HDQ Communication	7	13.3	Trademarks	30
8.14	Timing Requirements: I ² C-Compatible Interface	8	13.4	Electrostatic Discharge Caution	30
8.15	Typical Characteristics	9	13.5	Glossary	30
			14	Mechanical, Packaging, and Orderable Information	30

5 Revision History

DATE	REVISION	NOTES
April 2015	*	Initial Release

6 Device Comparison Table

PRODUCTION PART NO. ⁽¹⁾	PACKAGE	T _A	COMMUNICATION FORMAT	TAPE AND REEL QUANTITY
bq27542DRZR-G1	SON-12	–40°C to 85°C	I ² C, HDQ ⁽¹⁾	3000
bq27542DRZT-G1				250

(1) The bq27542-G1 device is shipped in I²C mode.

7 Pin Configurations and Functions

(Top View)

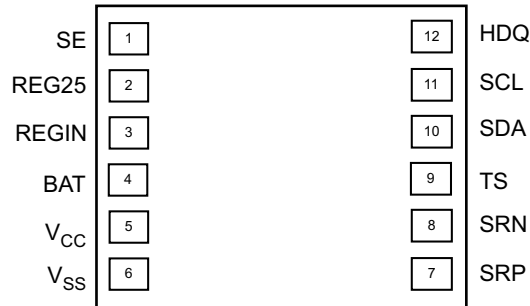

Pin Functions

PIN		TYPE ⁽¹⁾	DESCRIPTION
NAME	NUMBER		
BAT	4	I	Cell-voltage measurement input. ADC input. Decouple with 0.1- μ F capacitor.
HDQ	12	I/O	HDQ serial communications line (Slave). Open-drain. Use with 10-k Ω pullup resistor (typical) or leave floating when it is not used.
REG25	2	P	2.5-V output voltage of the internal integrated LDO. Connect a minimum 0.47- μ F ceramic capacitor.
REGIN	3	P	The input voltage for the internal integrated LDO. Connect a 0.1- μ F ceramic capacitor.
SCL	11	I	Slave I ² C serial communications clock input line for communication with the system (slave). Open-drain I/O. Use with a 10-k Ω pullup resistor (typical).
SDA	10	I/O	Slave I ² C serial communications data line for communication with the system (slave). Open-drain I/O. Use with a 10-k Ω pullup resistor (typical).
SE	1	O	Shutdown Enable output. Push-pull output. Leave floating when it is not used.
SRN	8	IA	Analog input pin connected to the internal coulomb counter with a Kelvin connection where SRN is nearest the PACK– connection. Connect to 5-m Ω to 20-m Ω sense resistor.
SRP	7	IA	Analog input pin connected to the internal coulomb counter with a Kelvin connection where SRP is nearest the CELL– connection. Connect to 5-m Ω to 20-m Ω sense resistor.
TS	9	IA	Pack thermistor voltage sense (use 103AT-type thermistor). ADC input
V _{CC}	5	P	Processor power input. The minimum 0.47- μ F capacitor connected to REG25 should be close to V _{CC} .
V _{SS}	6	P	Device ground

(1) I/O = Digital input/output, IA = Analog input, P = Power connection

8 Specifications

8.1 Absolute Maximum Ratings

 Over-operating free-air temperature range (unless otherwise noted)⁽¹⁾

		MIN	MAX	UNIT
V _I	Regulator input, REGIN	-0.3	24	V
V _{CC}	Supply voltage range	-0.3	2.75	V
V _{IOD}	Open-drain I/O pins (SDA, SCL, HDQ)	-0.3	6	V
V _{BAT}	BAT input (pin 4)	-0.3	6	V
V _I	Input voltage range to all others (pins 1, 7, 8, 9)	-0.3	V _{CC} + 0.3	V
T _F	Functional temperature range	-40	100	°C
T _{stg}	Storage temperature	-65	150	°C

(1) Stresses beyond those listed under *Absolute Maximum Ratings* may cause permanent damage to the device. These are stress ratings only, which do not imply functional operation of the device at these or any other conditions beyond those indicated under *Recommended Operating Conditions*. Exposure to absolute-maximum-rated conditions for extended periods may affect device reliability.

8.2 ESD Ratings

			VALUE	UNIT	
V _(ESD)	Electrostatic discharge	Human-body model (HBM), per ANSI/ESDA/JEDEC JS-001 ⁽¹⁾	All pins except 4 (BAT)	±2000	V
			Pin 4 (BAT)	±1500	
		Charged-device model (CDM), per JEDEC specification JESD22-C101 ⁽²⁾	All pins	±250	

(1) JEDEC document JEP155 states that 500-V HBM allows safe manufacturing with a standard ESD control process.

(2) JEDEC document JEP157 states that 250-V CDM allows safe manufacturing with a standard ESD control process.

8.3 Recommended Operating Conditions

 T_A = -40°C to 85°C; typical values at T_A = 25°C and V_(REGIN) = V_{BAT} = 3.6 V (unless otherwise noted)

			MIN	NOM	MAX	UNIT
V _I	Supply voltage, REGIN	No operating restrictions	2.7		5.5	V
		No FLASH writes	2.45		2.7	
I _{CC}	Normal operating mode current ⁽¹⁾	Fuel gauge in NORMAL mode I _{LOAD} > Sleep Current		131		µA
I _(SLP)	Low-power operating mode current ⁽¹⁾	Fuel gauge in SLEEP mode I _{LOAD} < Sleep Current		60		µA
I _(FULLSLP)	Low-power operating mode current ⁽¹⁾	Fuel gauge in FULLSLEEP mode I _{LOAD} < Sleep Current		21		µA
I _(HIB)	Hibernate operating mode current ⁽¹⁾	Fuel gauge in HIBERNATE mode Available in I ² C mode only. I _{LOAD} < Hibernate Current		6		µA
V _{OL}	Output voltage low (HDQ, SDA, SCL, SE)	I _{OL} = 3 mA			0.4	V
V _{OH(PP)}	Output high voltage (SE)	I _{OH} = -1 mA	V _{CC} - 0.5			V
V _{OH(OD)}	Output high voltage (HDQ, SDA, SCL)	External pullup resistor connected to V _{CC}	V _{CC} - 0.5			V
V _{IL}	Input voltage low (HDQ, SDA, SCL)		-0.3		0.6	V
V _{IH}	Input voltage high (HDQ, SDA, SCL)		1.2		6	V
V _(A1)	Input voltage range (TS)		V _{SS} - 0.125		2	V
V _(A2)	Input voltage range (BAT)		V _{SS} - 0.125		5	V
V _(A3)	Input voltage range (SRP, SRN)		V _{SS} - 0.125		0.125	V
I _{lkg}	Input leakage current (I/O pins)				0.3	µA
t _{PUCD}	Power-up communication delay			250		ms

(1) Specified by design. Not tested in production.

8.4 Thermal Information

Over-operating free-air temperature range (unless otherwise noted)

THERMAL METRIC ⁽¹⁾		bq27542-G1			UNIT
		DRZ			
		(12 PINS)			
R _{θJA}	Junction-to-ambient thermal resistance	64.1			°C/W
R _{θJC(top)}	Junction-to-case (top) thermal resistance	59.8			
R _{θJB}	Junction-to-board thermal resistance	52.7			
Ψ _{JT}	Junction-to-top characterization parameter	0.3			
Ψ _{JB}	Junction-to-board characterization parameter	28.3			
R _{θJC(bot)}	Junction-to-case (bottom) thermal resistance	2.4			

(1) For more information about traditional and new thermal metrics, see the *Semiconductor and IC Package Thermal Metrics* application report, [SPRA953](#).

8.5 Electrical Characteristics: Power-On Reset

T_A = –40°C to 85°C, C_(REG) = 0.47 μF, 2.45 V < V_(REGIN) = V_{BAT} < 5.5 V; typical values at T_A = 25°C and V_(REGIN) = V_{BAT} = 3.6 V (unless otherwise noted)

PARAMETER	TEST CONDITIONS	MIN	TYP	MAX	UNIT
V _{IT+}	Positive-going battery voltage input at V _{CC}	2.05	2.20	2.31	V
V _{HYS}	Power-on reset hysteresis		115		mV

8.6 2.5-V LDO Regulator ⁽¹⁾

T_A = –40°C to 85°C, C_(REG) = 0.47 μF, 2.45 V < V_(REGIN) = V_{BAT} < 5.5 V; typical values at T_A = 25°C and V_(REGIN) = V_{BAT} = 3.6 V (unless otherwise noted)

PARAMETER	TEST CONDITIONS		MIN	TYP	MAX	UNIT
V _O	Regulator output voltage, REG25	2.7 V ≤ V _(REGIN) ≤ 5.5 V, I _{OUT} ≤ 16 mA	2.4	2.5	2.6	V
		2.45 V ≤ V _(REGIN) < 2.7 V (low battery), I _{OUT} ≤ 3 mA				
I _{OS} ⁽²⁾	Short circuit current limit	V _(REG25) = 0 V			250	mA

(1) LDO output current, I_{OUT}, is the total load current. LDO regulator should be used to power internal fuel gauge only.

(2) Specified by design. Not production tested.

8.7 Internal Temperature Sensor Characteristics

T_A = –40°C to 85°C, C_(REG) = 0.47 μF, 2.45 V < V_(REGIN) = V_{BAT} < 5.5 V; typical values at T_A = 25°C and V_(REGIN) = V_{BAT} = 3.6 V (unless otherwise noted)

PARAMETER	TEST CONDITIONS	MIN	TYP	MAX	UNIT
G _(TEMP)	Temperature sensor voltage gain		–2.0		mV/°C

8.8 Internal Clock Oscillators

T_A = –40°C to 85°C, C_(REG) = 0.47 μF, 2.45 V < (V_(REGIN) = V_{BAT}) < 5.5 V; typical values at T_A = 25°C and V_(REGIN) = V_{BAT} = 3.6 V (unless otherwise noted)

PARAMETER	TEST CONDITIONS	MIN	TYP	MAX	UNIT
f _(OSC)	Operating frequency		8.389		MHz
f _(LOSC)	Operating frequency		32.768		kHz

8.9 Integrating ADC (Coulomb Counter) Characteristics

$T_A = -40^{\circ}\text{C}$ to 85°C , $C_{\text{REG}} = 0.47\ \mu\text{F}$, $2.45\ \text{V} < V_{\text{(REGIN)}} = V_{\text{BAT}} < 5.5\ \text{V}$; typical values at $T_A = 25^{\circ}\text{C}$ and $V_{\text{(REGIN)}} = V_{\text{BAT}} = 3.6\ \text{V}$ (unless otherwise noted)

PARAMETER		TEST CONDITIONS	MIN	TYP	MAX	UNIT
$V_{\text{IN(SR)}}$	Input voltage range, $V_{\text{(SRN)}}$ and $V_{\text{(SRP)}}$	$V_{\text{SR}} = V_{\text{(SRN)}} - V_{\text{(SRP)}}$	-0.125		0.125	V
$t_{\text{CONV(SR)}}$	Conversion time	Single conversion		1		s
	Resolution		14		15	bits
$V_{\text{OS(SR)}}$	Input offset			10		μV
I_{NL}	Integral nonlinearity error			± 0.007	± 0.034	FSR
$Z_{\text{IN(SR)}}$	Effective input resistance ⁽¹⁾		2.5			M Ω
$I_{\text{lkq(SR)}}$	Input leakage current ⁽¹⁾				0.3	μA

(1) Specified by design. Not production tested.

8.10 ADC (Temperature and Cell Voltage) Characteristics

$T_A = -40^{\circ}\text{C}$ to 85°C , $C_{\text{REG}} = 0.47\ \mu\text{F}$, $2.45\ \text{V} < V_{\text{(REGIN)}} = V_{\text{BAT}} < 5.5\ \text{V}$; typical values at $T_A = 25^{\circ}\text{C}$ and $V_{\text{(REGIN)}} = V_{\text{BAT}} = 3.6\ \text{V}$ (unless otherwise noted)

PARAMETER		TEST CONDITIONS	MIN	TYP	MAX	UNIT
$V_{\text{IN(ADC)}}$	Input voltage range		-0.2		1	V
$t_{\text{CONV(ADC)}}$	Conversion time				125	ms
	Resolution		14		15	bits
$V_{\text{OS(ADC)}}$	Input offset			1		mV
$Z_{\text{(ADC1)}}$	Effective input resistance (TS) ⁽¹⁾			5		k Ω
$Z_{\text{(ADC2)}}$	Effective input resistance (BAT) ⁽¹⁾	bq27542-G1 not measuring cell voltage	8			M Ω
		bq27542-G1 measuring cell voltage		100		k Ω
$I_{\text{lkq(ADC)}}$	Input leakage current ⁽¹⁾				0.3	μA

(1) Specified by design. Not production tested.

8.11 Data Flash Memory Characteristics

$T_A = -40^{\circ}\text{C}$ to 85°C , $C_{\text{REG}} = 0.47\ \mu\text{F}$, $2.45\ \text{V} < V_{\text{(REGIN)}} = V_{\text{BAT}} < 5.5\ \text{V}$; typical values at $T_A = 25^{\circ}\text{C}$ and $V_{\text{(REGIN)}} = V_{\text{BAT}} = 3.6\ \text{V}$ (unless otherwise noted)

PARAMETER		TEST CONDITIONS	MIN	TYP	MAX	UNIT
t_{DR}	Data retention ⁽¹⁾		10			Years
	Flash programming write-cycles ⁽¹⁾		20,000			Cycles
t_{WORDPROG}	Word programming time ⁽¹⁾				2	ms
I_{CCPROG}	Flash-write supply current ⁽¹⁾			5	10	mA

(1) Specified by design. Not production tested.

8.12 Timing Requirements

$T_A = -40^{\circ}\text{C}$ to 85°C , $C_{\text{REG}} = 0.47\ \mu\text{F}$, $2.45\ \text{V} < V_{\text{REGIN}} = V_{\text{BAT}} < 5.5\ \text{V}$; typical values at $T_A = 25^{\circ}\text{C}$ and $V_{\text{REGIN}} = V_{\text{BAT}} = 3.6\ \text{V}$ (unless otherwise noted)

PARAMETER		TEST CONDITIONS	MIN	NOM	MAX	UNIT
t_r	SCL/SDA rise time				300	ns
t_f	SCL/SDA fall time				300	ns
$t_{\text{w(H)}}$	SCL pulse width (high)		600			ns
$t_{\text{w(L)}}$	SCL pulse width (low)		1.3			μs
$t_{\text{su(STA)}}$	Setup for repeated start		600			ns
$t_{\text{d(STA)}}$	Start to first falling edge of SCL		600			ns
$t_{\text{su(DAT)}}$	Data setup time		1000			ns
$t_{\text{h(DAT)}}$	Data hold time		0			ns

Timing Requirements (continued)

$T_A = -40^{\circ}\text{C}$ to 85°C , $C_{\text{REG}} = 0.47\ \mu\text{F}$, $2.45\ \text{V} < V_{\text{REGIN}} = V_{\text{BAT}} < 5.5\ \text{V}$; typical values at $T_A = 25^{\circ}\text{C}$ and $V_{\text{REGIN}} = V_{\text{BAT}} = 3.6\ \text{V}$ (unless otherwise noted)

PARAMETER	TEST CONDITIONS	MIN	NOM	MAX	UNIT
$t_{\text{SU(STOP)}}$	Setup time for stop	600			ns
t_{BUF}	Bus free time between stop and start	66			μs
f_{SCL}	Clock frequency			400	kHz

8.13 Timing Requirements: HDQ Communication

$T_A = -40^{\circ}\text{C}$ to 85°C , $C_{\text{REG}} = 0.47\ \mu\text{F}$, $2.45\ \text{V} < V_{\text{REGIN}} = V_{\text{BAT}} < 5.5\ \text{V}$; typical values at $T_A = 25^{\circ}\text{C}$ and $V_{\text{REGIN}} = V_{\text{BAT}} = 3.6\ \text{V}$ (unless otherwise noted)

PARAMETER	TEST CONDITIONS	MIN	NOM	MAX	UNIT
$t_{\text{(CYCH)}}$	Cycle time, host to bq27542-G1	190			μs
$t_{\text{(CYCD)}}$	Cycle time, bq27542-G1 to host	190	205	250	μs
$t_{\text{(HW1)}}$	Host sends 1 to bq27542-G1	0.5		50	μs
$t_{\text{(DW1)}}$	bq27542-G1 sends 1 to host	32		50	μs
$t_{\text{(HW0)}}$	Host sends 0 to bq27542-G1	86		145	μs
$t_{\text{(DW0)}}$	bq27542-G1 sends 0 to host	80		145	μs
$t_{\text{(RSPS)}}$	Response time, bq27542-G1 to host	190		950	μs
$t_{\text{(B)}}$	Break time	190			μs
$t_{\text{(BR)}}$	Break recovery time	40			μs
$t_{\text{(RISE)}}$	HDQ line rising time to logic 1 (1.2 V)			950	ns
$t_{\text{(TRND)}}$	Turnaround time (time from the falling edge of the last transmitted bit of 8-bit data and the falling edge of the next Break signal)	210			μs

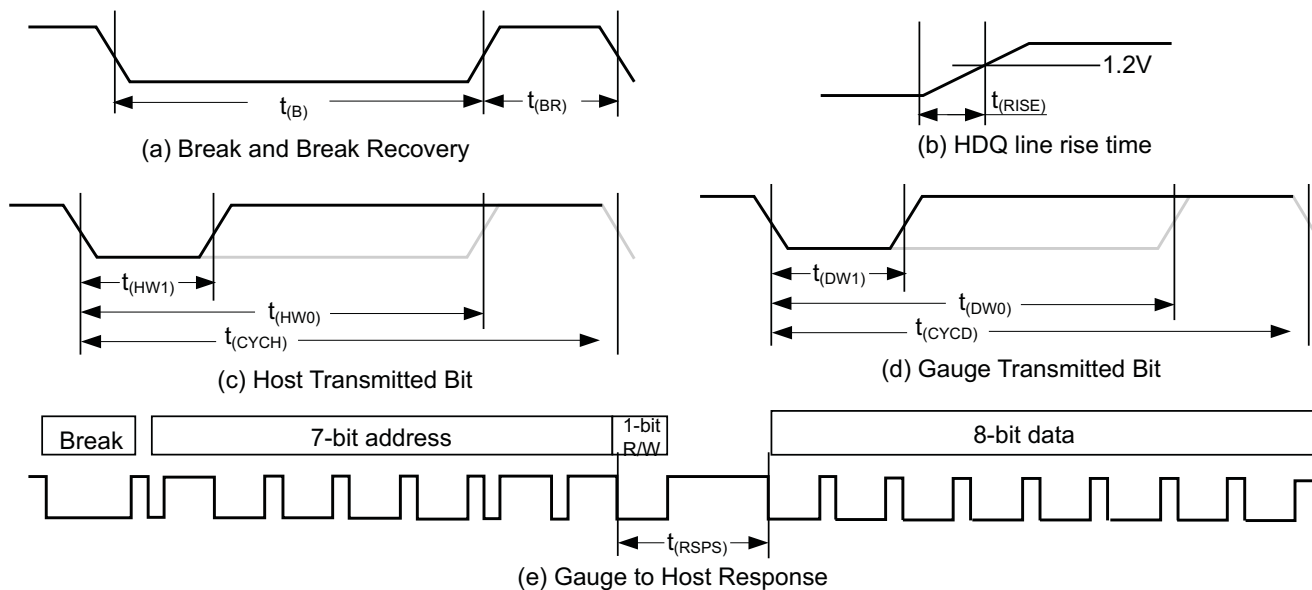

Figure 1. Timing Diagram, HDQ

8.14 Timing Requirements: I²C-Compatible Interface

$T_A = -40^\circ\text{C}$ to 85°C , $C_{\text{REG}} = 0.47\mu\text{F}$, $2.45\text{ V} < V_{\text{REGIN}} = V_{\text{BAT}} < 5.5\text{ V}$; typical values at $T_A = 25^\circ\text{C}$ and $V_{\text{REGIN}} = V_{\text{BAT}} = 3.6\text{ V}$ (unless otherwise noted)

PARAMETER		TEST CONDITIONS	MIN	NOM	MAX	UNIT
t_r	SCL/SDA rise time				300	ns
t_f	SCL/SDA fall time				300	ns
$t_{w(H)}$	SCL pulse width (high)		600			ns
$t_{w(L)}$	SCL pulse width (low)		1.3			μs
$t_{\text{su(STA)}}$	Setup for repeated start		600			ns
$t_{\text{d(STA)}}$	Start to first falling edge of SCL		600			ns
$t_{\text{su(DAT)}}$	Data setup time		1000			ns
$t_{\text{h(DAT)}}$	Data hold time		0			ns
$t_{\text{su(STOP)}}$	Setup time for stop		600			ns
t_{BUF}	Bus free time between stop and start		66			μs
f_{SCL}	Clock frequency				400	kHz

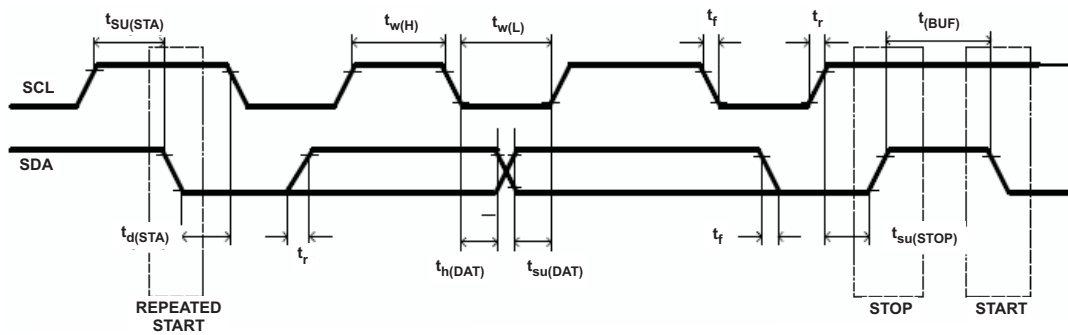

Figure 2. I²C-Compatible Interface Timing Diagrams

8.15 Typical Characteristics

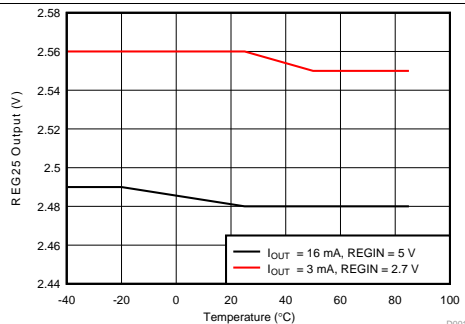

Figure 3. REG25 vs. Temperature

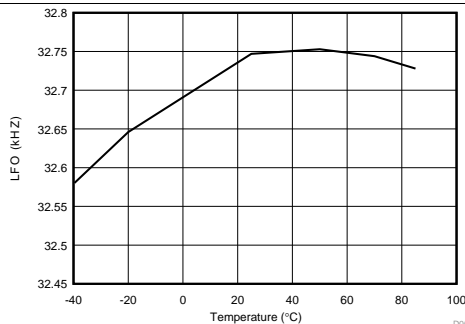

Figure 4. Low Frequency Oscillator vs. Temperature

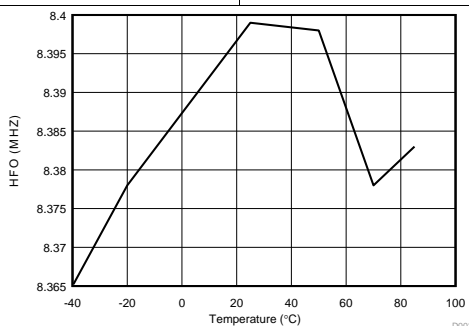

Figure 5. High Frequency Oscillator vs. Temperature

9 Detailed Description

9.1 Overview

The bq27542-G1 fuel gauge accurately predicts the battery capacity and other operational characteristics of a single Li-based rechargeable cell. It can be interrogated by a system processor to provide cell information, such as state-of-charge (SOC), time-to-empty (TTE), and time-to-full (TTF).

To minimize power consumption, the fuel gauge has different power modes: NORMAL, SLEEP, FULLSLEEP, and HIBERNATE. The fuel gauge passes automatically between these modes, depending upon the occurrence of specific events, though a system processor can initiate some of these modes directly. More details can be found in [Device Functional Modes](#).

NOTE

The following formatting conventions are used in this document:

Commands: *italics* with parentheses() and no breaking spaces, for example: *RemainingCapacity()*

Data Flash: *italics*, **bold**, and breaking spaces, for example: ***Design Capacity***

Register Bits and Flags: *italics* with brackets[], for example: *[TDA]*

Data Flash Bits: *italics*, **bold**, and brackets[], for example: ***[LED1]***

Modes and States: All capitals, for example: UNSEALED mode

9.2 Functional Block Diagram

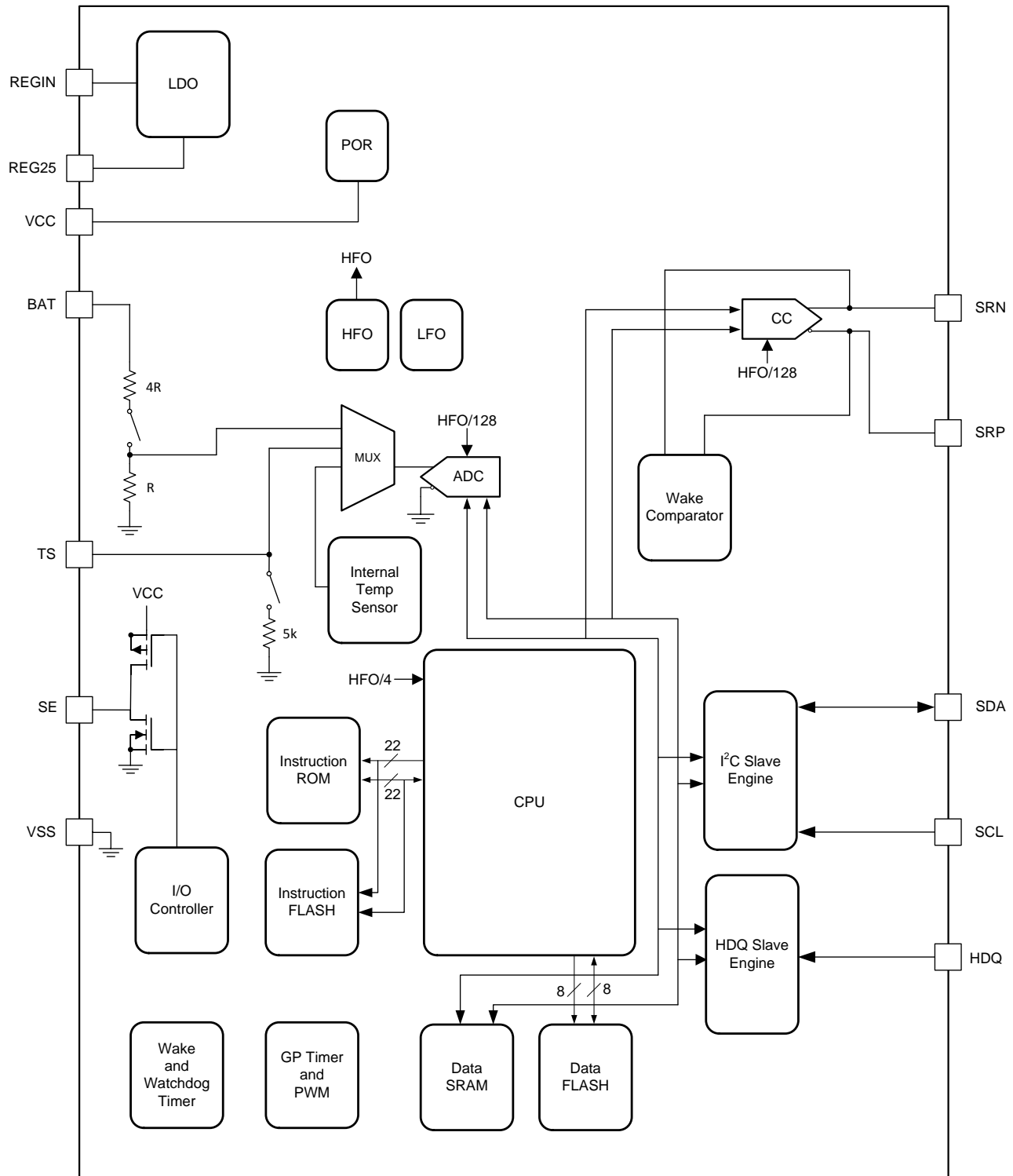

9.3 Feature Description

9.3.1 Fuel Gauging

The fuel gauge measures the cell voltage, temperature, and current to determine battery SOC based on the Impedance Track algorithm. (Refer to the *Theory and Implementation of Impedance Track Battery Fuel-Gauging Algorithm Application Report* [SLUA450] for more information.) The fuel gauge monitors charge and discharge activity by sensing the voltage across a small-value resistor (5-mΩ to 20-mΩ, typical) between the SRP and SRN pins and in series with the cell. By integrating the charge passing through the battery, the battery SOC is adjusted during battery charge or discharge.

The total battery capacity is found by comparing states of charge before and after applying the load with the amount of charge passed. When an application load is applied, the impedance of the cell is measured by comparing the OCV obtained from a predefined function for present SOC with the measured voltage under load. Measurements of OCV and charge integration determine chemical state of charge and chemical capacity (Qmax). The initial Qmax values are taken from a cell manufacturers' data sheet multiplied by the number of parallel cells. It is also used for the value in **Design Capacity**. The fuel gauge acquires and updates the battery-impedance profile during normal battery usage. It uses this profile, along with SOC and the Qmax value, to determine *FullChargeCapacity()* and *StateOfCharge()*, specifically for the present load and temperature. *FullChargeCapacity()* is reported as capacity available from a fully charged battery under the present load and temperature until *Voltage()* reaches the **Terminate Voltage**. *NominalAvailableCapacity()* and *FullAvailableCapacity()* are the uncompensated (no or light load) versions of *RemainingCapacity()* and *FullChargeCapacity()*, respectively.

9.3.2 Impedance Track Variables

The fuel gauge has several data flash variables that permit the user to customize the Impedance Track algorithm for optimized performance. These variables depend on the power characteristics of the application, as well as the cell itself.

9.3.3 System Control Function

The fuel gauge provides system control functions that allow the fuel gauge to enter SHUTDOWN mode to power-off with the assistance of an external circuit or provide interrupt function to the system. [Table 1](#) shows the configurations for SE and HDQ pins.

Table 1. SE and HDQ Pin Functions

[INTSEL]	COMMUNICATION MODE	SE PIN FUNCTION	HDQ PIN FUNCTION
0 (default)	I ² C	Interrupt Mode ⁽¹⁾	Not Used
	HDQ		HDQ Mode ⁽²⁾
1	I ² C	Shutdown Mode	Interrupt Mode
	HDQ		HDQ Mode ⁽²⁾

(1) [SE_EN] bit in **Pack Configuration** can be enabled to use [SE] and [SHUTDOWN] bits in *CONTROL_STATUS()* function. The SE pin shutdown function is disabled.

(2) HDQ pin is used for communication and HDQ Host Interrupt Feature is available.

9.3.3.1 SHUTDOWN Mode

In SHUTDOWN mode, the SE pin is used to signal external circuit to power-off the fuel gauge. This feature is useful to shut down the fuel gauge in a deeply discharged battery to protect the battery. By default, SHUTDOWN mode is in NORMAL state. By sending the SET_SHUTDOWN subcommand or setting the [SE_EN] bit in **the Pack Configuration** register, the [SHUTDOWN] bit is set and enables the shutdown feature. When this feature is enabled and [INTSEL] is set, the SE pin can be in NORMAL state or SHUTDOWN state. The SHUTDOWN state can be entered in HIBERNATE mode (only if HIBERNATE mode is enabled due to low cell voltage). All other power modes will default the SE pin to NORMAL state. [Table 2](#) shows the SE pin state in NORMAL or SHUTDOWN mode. The CLEAR_SHUTDOWN subcommand or clearing [SE_EN] bit in the **Pack Configuration** register can be used to disable SHUTDOWN mode.

The SE pin will be high impedance at power-on reset (POR); the [SE_POL] does not affect the state of SE pin at POR. Also, [SE_PU] configuration changes will only take effect after POR. In addition, the [INTSEL] only controls the behavior of the SE pin; it does not affect the function of [SE] and [SHUTDOWN] bits.

Table 2. SE Pin State

		SHUTDOWN Mode [INTSEL] = 1 and ([SE_EN] or [SHUTDOWN] = 1)	
[SE_PU]	[SE_POL]	NORMAL State	SHUTDOWN State
0	0	High Impedance	0
0	1	0	High Impedance
1	0	1	0
1	1	0	1

9.3.3.2 INTERRUPT Mode

By using the INTERRUPT mode, the system can be interrupted based on detected fault conditions, as specified in Table 5. The SE or HDQ pin can be selected as the interrupt pin by configuring the [INTSEL] bit based on SE and HDQ pin functions. In addition, the pin polarity and pullup (SE pin only) can be configured according to the system's needs, as described in Table 3 or Table 4.

Table 3. SE Pin in Interrupt Mode ([INTSEL] = 0)

[SE_PU]	[INTPOL]	INTERRUPT CLEAR	INTERRUPT SET
0	0	High Impedance	0
0	1	0	High Impedance
1	0	1	0
1	1	0	1

Table 4. HDQ Pin in Interrupt Mode ([INTSEL] = 1)

[INTPOL]	INTERRUPT CLEAR	INTERRUPT SET
0	High Impedance	0
1	0	High Impedance

Table 5. Interrupt Mode Fault Conditions

INTERRUPT CONDITION	Flags() STATUS BIT	ENABLE CONDITION	COMMENT
SOC1 Set	[SOC1]	Always	This interrupt is raised when the [SOC1] flag is set.
Battery High	[BATHI]	Always	This interrupt is raised when the [BATHI] flag is set.
Battery Low	[BATLOW]	Always	This interrupt is raised when the [BATLOW] flag is set.
Over-Temperature Charge	[OTC]	OT Chg Time ≠ 0	This interrupt is raised when the [OTC] flag is set.
Over-Temperature Discharge	[OTD]	OT Dsg Time ≠ 0	This interrupt is raised when the [OTD] flag is set.
Internal Short Detection	[ISD]	[SE_ISD] = 1 in Pack Configuration B	This interrupt is raised when the [ISD] flag is set.
Tab Disconnect Detection	[TDD]	[SE_TDD] = 1 in Pack Configuration B	This interrupt is raised when the [TDD] flag is set.
I _{max}	[IMAX]	[IMAXEN] = 1 in Pack Configuration D	This interrupt is raised when the [IMAX] flag is set.
Battery Trip Point (BTP)	[SOC1]	[BTP_EN] = 1 in Pack Configuration C . The BTP interrupt supersedes all other interrupt sources, which are unavailable when BTP is active.	This interrupt is raised when RemainingCapacity() ≤ BTPSOC1Set() or RemainingCapacity() ≥ BTPSOC1Clear() during battery discharge or charge, respectively. The interrupt remains asserted until new values are written to the BTPSOC1Set() and BTPSOC1Clear() registers.

Device Functional Modes (continued)

9.4.2 SLEEP Mode

SLEEP mode is entered automatically if the feature is enabled (**Pack Configuration [SLEEP] = 1**) and *AverageCurrent()* is below the programmable level **Sleep Current**. Once entry into SLEEP mode has been qualified, but prior to entering it, the fuel gauge performs an ADC autocalibration to minimize offset.

While in SLEEP mode, the fuel gauge can suspend serial communications as much as 4 ms by holding the comm line(s) low. This delay is necessary to correctly process host communication, since the fuel gauge processor is mostly halted in SLEEP mode.

During the SLEEP mode, the fuel gauge periodically takes data measurements and updates its data set. However, a majority of its time is spent in an idle condition.

The fuel gauge exits SLEEP if any entry condition is broken, specifically when: (1) *AverageCurrent()* rises above **Sleep Current**, or (2) a current in excess of I_{WAKE} through R_{SENSE} is detected when the I_{WAKE} comparator is enabled.

9.4.3 FULLSLEEP Mode

FULLSLEEP mode is entered automatically when the bq27542-G1 is in SLEEP mode and the timer counts down to 0 (*Full Sleep Wait Time* > 0). FULLSLEEP mode is entered immediately after entry to SLEEP if **Full Sleep Wait Time** is set to 0 and the host sets the **[FULLSLEEP]** bit in the CONTROL_STATUS register using the SET_FULLSLEEP subcommand.

During FULLSLEEP mode, the fuel gauge periodically takes data measurements and updates its data set. However, a majority of its time is spent in an idle condition.

The gauge exits the FULLSLEEP mode when there is any communication activity. The **[FULLSLEEP]** bit can remain set (*Full Sleep Wait Time* > 0) or be cleared (*Full Sleep Wait Time* ≤ 0) after exit of FULLSLEEP mode. Therefore, EVSW communication activity might cause the gauge to exit FULLSLEEP MODE and display the **[FULLSLEEP]** bit as clear. The execution of SET_FULLSLEEP to set **[FULLSLEEP]** bit is required when *Full Sleep Wait Time* ≤ 0 in order to re-enter FULLSLEEP mode.

While in FULLSLEEP mode, the fuel gauge can suspend serial communications as much as 4 ms by holding the comm line(s) low. This delay is necessary to correctly process host communication, since the fuel gauge processor is mostly halted in SLEEP mode.

The fuel gauge exits FULLSLEEP if any entry condition is broken, specifically when: (1) *AverageCurrent()* rises above **Sleep Current**, or (2) a current in excess of I_{WAKE} through R_{SENSE} is detected when the I_{WAKE} comparator is enabled.

9.4.4 HIBERNATE Mode

HIBERNATE mode should be used for long-term pack storage or when the host system needs to enter a low-power state, and minimal gauge power consumption is required. This mode is ideal when the host is set to its own HIBERNATE, SHUTDOWN, or OFF modes. The gauge waits to enter HIBERNATE mode until it has taken a valid OCV measurement (cell relaxed) and the value of the average cell current has fallen below Hibernate Current. When the conditions are met, the fuel gauge can enter HIBERNATE due to either low cell voltage or by having the **[HIBERNATE]** bit of the CONTROL_STATUS register set. The gauge will remain in HIBERNATE mode until any communication activity appears on the communication lines and the address is for bq27541. In addition, the SE pin shutdown mode function is supported only when the fuel gauge enters HIBERNATE due to low cell voltage.

When the gauge wakes up from HIBERNATE mode, the **[HIBERNATE]** bit of the CONTROL_STATUS register is cleared. The host is required to set the bit to allow the gauge to re-enter HIBERNATE mode if desired.

Device Functional Modes (continued)

Because the fuel gauge is dormant in HIBERNATE mode, the battery should not be charged or discharged in this mode, because any changes in battery charge status will not be measured. If necessary, the host equipment can draw a small current (generally infrequent and less than 1 mA, for purposes of low-level monitoring and updating); however, the corresponding charge drawn from the battery will not be logged by the gauge. Once the gauge exits to NORMAL mode, the IT algorithm will take about 3 seconds to re-establish the correct battery capacity and measurements, regardless of the total charge drawn in HIBERNATE mode. During this period of re-establishment, the gauge reports values previously calculated prior to entering HIBERNATE mode. The host can identify exit from HIBERNATE mode by checking if $Voltage() < \text{Hibernate Voltage}$ or $[HIBERNATE]$ bit is cleared by the gauge.

If a charger is attached, the host should immediately take the fuel gauge out of HIBERNATE mode before beginning to charge the battery. Charging the battery in HIBERNATE mode will result in a notable gauging error that will take several hours to correct. It is also recommended to minimize discharge current during exit from HIBERNATE.

9.5 Programming

9.5.1 Standard Data Commands

The fuel gauge uses a series of 2-byte standard commands to enable system reading and writing of battery information. Each standard command has an associated command-code pair, as indicated in [Table 6](#). Each protocol has specific means to access the data at each Command Code. DataRAM is updated and read by the gauge only once per second. Standard commands are accessible in NORMAL operation mode.

Table 6. Standard Commands

COMMAND NAME	COMMAND CODE	UNIT	SEALED ACCESS
<i>Control()</i>	0x00 and 0x01	—	RW
<i>AtRate()</i>	0x02 and 0x03	mA	RW
<i>UnfilteredSOC()</i>	0x04 and 0x05	%	R
<i>Temperature()</i>	0x06 and 0x07	0.1°K	R
<i>Voltage()</i>	0x08 and 0x09	mV	R
<i>Flags()</i>	0x0A and 0x0B	—	R
<i>NomAvailableCapacity()</i>	0x0C and 0x0D	mAh	R
<i>FullAvailableCapacity()</i>	0x0E and 0x0F	mAh	R
<i>RemainingCapacity()</i>	0x10 and 0x11	mAh	R
<i>FullChargeCapacity()</i>	0x12 and 0x13	mAh	R
<i>AverageCurrent()</i>	0x14 and 0x15	mA	R
<i>TimeToEmpty()</i>	0x16 and 0x17	min	R
<i>FullChargeCapacityFiltered()</i>	0x18 and 0x19	mAh	R
<i>SafetyStatus()</i>	0x1A and 0x1B	—	R
<i>FullChargeCapacityUnfiltered()</i>	0x1C and 0x1D	mAh	R
<i>Imax()</i>	0x1E and 0x1F	mA	R
<i>RemainingCapacityUnfiltered()</i>	0x20 and 0x21	mAh	R
<i>RemainingCapacityFiltered()</i>	0x22 and 0x23	mAh	R
<i>BTPSOC1Set()</i>	0x24 and 0x25	mAh	RW
<i>BTPSOC1Clear()</i>	0x26 and 0x27	mAh	RW
<i>InternalTemperature()</i>	0x28 and 0x29	0.1°K	R
<i>CycleCount()</i>	0x2A and 0x2B	Counts	R
<i>StateofCharge()</i>	0x2C and 0x2D	%	R
<i>StateofHealth()</i>	0x2E and 0x2F	% / num	R
<i>ChargingVoltage()</i>	0x30 and 0x31	mV	R
<i>ChargingCurrent()</i>	0x32 and 0x33	mA	R

Programming (continued)

Table 6. Standard Commands (continued)

COMMAND NAME	COMMAND CODE	UNIT	SEALED ACCESS
<i>PassedCharge()</i>	0x34 and 0x35	mAh	R
<i>DOD0()</i>	0x36 and 0x37	hex	R
<i>SelfDischargeCurrent()</i>	0x34 and 0x35	mA	R

9.5.1.1 Control(): 0x00 and 0x01

Issuing a *Control()* command requires a subsequent 2-byte subcommand. These additional bytes specify the particular control function desired. The *Control()* command allows the system to control specific features of the fuel gauge during normal operation and additional features when the fuel gauge is in different access modes, as described in [Table 7](#).

Table 7. Control() Subcommands

SUBCOMMAND NAME	SUBCOMMAND CODE	SEALED ACCESS	DESCRIPTION
CONTROL_STATUS	0x0000	Yes	Reports the status of DF Checksum, Impedance Track, and so on
DEVICE_TYPE	0x0001	Yes	Reports the device type of 0x0541 (indicating bq27542-G1)
FW_VERSION	0x0002	Yes	Reports the firmware version on the device type
HW_VERSION	0x0003	Yes	Reports the hardware version on the device type
RESET_DATA	0x0005	Yes	Returns reset data
PREV_MACWRITE	0x0007	Yes	Returns previous <i>Control()</i> subcommand code
CHEM_ID	0x0008	Yes	Reports the chemical identifier of the Impedance Track configuration
BOARD_OFFSET	0x0009	No	Forces the device to measure and store the board offset
CC_OFFSET	0x000A	No	Forces the device to measure the CC offset
DF_VERSION	0x000C	Yes	Reports the data flash version of the device
SET_FULLSLEEP	0x0010	Yes	Sets the <i>CONTROL_STATUS[FULLSLEEP]</i> bit to 1
SET_SHUTDOWN	0x0013	Yes	Sets the <i>CONTROL_STATUS[SHUTDWN]</i> bit to 1
CLEAR_SHUTDOWN	0x0014	Yes	Clears the <i>CONTROL_STATUS[SHUTDWN]</i> bit to 1
SET_HDQINTEN	0x0015	Yes	Forces CONTROL_STATUS [HDQHOSTIN] to 1
CLEAR_HDQINTEN	0x0016	Yes	Forces CONTROL_STATUS [HDQHOSTIN] to 0
STATIC_CHEM_CHKSUM	0x0017	Yes	Calculates chemistry checksum
ALL_DF_CHKSUM	0x0018	Yes	Reports checksum for all data flash excluding device specific variables
STATIC_DF_CHKSUM	0x0019	Yes	Reports checksum for static data flash excluding device specific variables
SYNC_SMOOTH	0x001E	Yes	Synchronizes RemCapSmooth() and FCCSmooth() with RemCapTrue() and FCCTrue()
SEALED	0x0020	No	Places the fuel gauge in SEALED access mode
IT_ENABLE	0x0021	No	Enables the Impedance Track algorithm
IMAX_INT_CLEAR	0x0023	Yes	Clears an Imax interrupt that is currently asserted on the RC2 pin
CAL_ENABLE	0x002D	No	Toggle CALIBRATION mode
RESET	0x0041	No	Forces a full reset of the fuel gauge
EXIT_CAL	0x0080	No	Exit CALIBRATION mode
ENTER_CAL	0x0081	No	Enter CALIBRATION mode
OFFSET_CAL	0x0082	No	Reports internal CC offset in CALIBRATION mode

9.6 Power Control

9.6.1 Reset Functions

When the fuel gauge detects a software reset by sending *[RESET] Control()* subcommand, it determines the type of reset and increments the corresponding counter. This information is accessible by issuing the command *Control()* function with the RESET_DATA subcommand.

Power Control (continued)

9.6.2 Wake-Up Comparator

The wake up comparator is used to indicate a change in cell current while the fuel gauge is in SLEEP modes. **Pack Configuration** uses bits **[RSNS1, RSNS0]** to set the sense resistor selection. **Pack Configuration** also uses the **[IWAKE]** bit to select one of two possible voltage threshold ranges for the given sense resistor selection. An internal interrupt is generated when the threshold is breached in either charge or discharge directions. Setting **[RSNS1]** and **[RSNS0]** to 0 disables this feature.

Table 8. I_{WAKE} Threshold Settings⁽¹⁾

IWAKE	RSNS1	RSNS0	Vth(SRP-SRN)
0	0	0	Disabled
1	0	0	Disabled
0	0	1	1.0 mV or –1.0 mV
1	0	1	2.2 mV or –2.2 mV
0	1	0	2.2 mV or –2.2 mV
1	1	0	4.6 mV or –4.6 mV
0	1	1	4.6 mV or –4.6 mV
1	1	1	9.8 mV or –9.8 mV

(1) The actual resistance value vs. the setting of the sense resistor is not important just the actual voltage threshold when calculating the configuration. The voltage thresholds are typical values under room temperature.

9.6.3 Flash Updates

Data Flash can only be updated if $Voltage() \geq \text{Flash Update OK Voltage}$. Flash programming current can cause an increase in LDO dropout. The value of **Flash Update OK Voltage** should be selected such that the V_{CC} voltage does not fall below its minimum of 2.4 V during Flash write operations.

9.7 Autocalibration

The fuel gauge provides an autocalibration feature that will measure the voltage offset error across SRP and SRN from time-to-time as operating conditions change. It subtracts the resulting offset error from normal sense resistor voltage, V_{SR} , for maximum measurement accuracy.

Autocalibration of the ADC begins on entry to SLEEP mode, except if $Temperature() \leq 5^{\circ}\text{C}$ or $Temperature() \geq 45^{\circ}\text{C}$.

The fuel gauge also performs a single offset calibration when: (1) the condition of $AverageCurrent() \leq 100 \text{ mA}$ and (2) {voltage change since last offset calibration $\geq 256 \text{ mV}$ } or {temperature change since last offset calibration is greater than 8°C for ≥ 60 seconds}.

Capacity and current measurements will continue at the last measured rate during the offset calibration when these measurements cannot be performed. If the battery voltage drops more than 32 mV during the offset calibration, the load current has likely increased considerably; hence, the offset calibration will be aborted.

9.8 Communications

9.8.1 HDQ Single-Pin Serial Interface

The HDQ interface is an asynchronous return-to-one protocol where a processor sends the command code to the fuel gauge. With HDQ, the least significant bit (LSB) of a data byte (command) or word (data) is transmitted first. Note that the DATA signal on pin 12 is open-drain and requires an external pullup resistor. The 8-bit command code consists of two fields: the 7-bit HDQ command code (bits 0:6) and the 1-bit RW field (MSB bit 7). The RW field directs the fuel gauge either to:

- Store the next 8 or 16 bits of data to a specified register, or
- Output 8 bits of data from the specified register

The HDQ peripheral can transmit and receive data as either an HDQ master or slave.

Communications (continued)

HDQ serial communication is normally initiated by the host processor sending a break command to the fuel gauge. A break is detected when the DATA pin is driven to a logic-low state for a time $t_{(B)}$ or greater. The DATA pin should then be returned to its normal ready high logic state for a time $t_{(BR)}$. The fuel gauge is now ready to receive information from the host processor.

The fuel gauge is shipped in the I²C mode. TI provides tools to enable the HDQ peripheral. The SLUA408 application report provides details of HDQ communication basics.

9.8.2 HDQ Host Interruption Feature

The default fuel gauge behaves as an HDQ slave only device when HDQ mode is enabled. If the HDQ interrupt function is enabled, the fuel gauge is capable of mastering and also communicating to a HDQ device. There is no mechanism for negotiating who is to function as the HDQ master and care must be taken to avoid message collisions. The interrupt is signaled to the host processor with the fuel gauge mastering an HDQ message. This message is a fixed message that will be used to signal the interrupt condition. The message itself is 0x80 (slave write to register 0x00) with no data byte being sent as the command is not intended to convey any status of the interrupt condition. The HDQ interrupt function is disabled by default and needs to be enabled by command.

When the SET_HDQINTEN subcommand is received, the fuel gauge will detect any of the interrupt conditions and assert the interrupt at 1-second intervals until the CLEAR_HDQINTEN command is received or the count of HDQHostIntrTries has lapsed.

The number of tries for interrupting the host is determined by the data flash parameter named *HDQHostIntrTries*.

9.8.2.1 Low Battery Capacity

This feature will work identically to SOC1. It will use the same data flash entries as SOC1 and will trigger interrupts as long as SOC1 = 1 and *HDQIntEN* = 1.

9.8.2.2 Temperature

This feature will trigger an interrupt based on the OTC (Over-Temperature in Charge) or OTD (Over-Temperature in Discharge) condition being met. It uses the same data flash entries as OTC or OTD and will trigger interrupts as long as either the OTD or OTC condition is met and *HDQIntEN* = 1.

9.8.3 I²C Interface

The fuel gauge supports the standard I²C read, incremental read, one-byte write quick read, and functions. The 7-bit device address (ADDR) is the most significant 7 bits of the hex address and is fixed as 1010101. The 8-bit device address is therefore 0xAA or 0xAB for write or read, respectively.

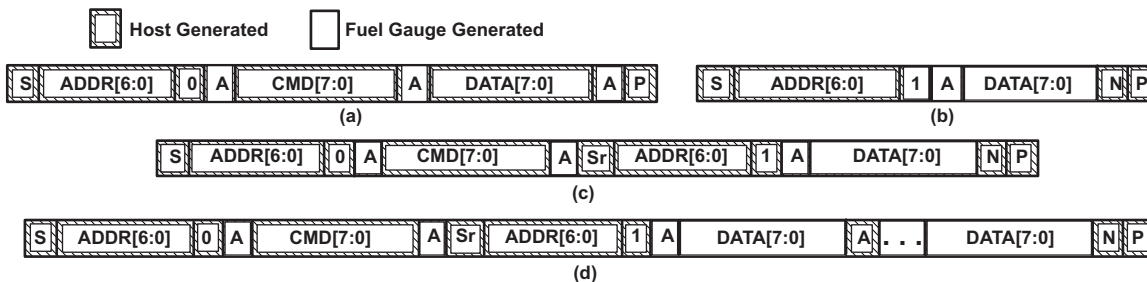

Figure 7. Supported I²C Formats

- (a) 1-byte write
- (b) Quick read
- (c) 1 byte-read
- (d) Incremental read (S = Start, Sr = Repeated Start, A = Acknowledge, N = No Acknowledge, and P = Stop)

Communications (continued)

The quick read returns data at the address indicated by the address pointer. The address pointer, a register internal to the I²C communication engine, increments whenever data is acknowledged by the fuel gauge or the I²C master. The quick writes function in the same manner and are a convenient means of sending multiple bytes to consecutive command locations (such as two-byte commands that require two bytes of data).

Attempt to write a read-only address (NACK after data sent by master):



Attempt to read an address above 0x7F (NACK command):



Attempt at incremental writes (NACK all extra data bytes sent):



Incremental read at the maximum allowed read address:

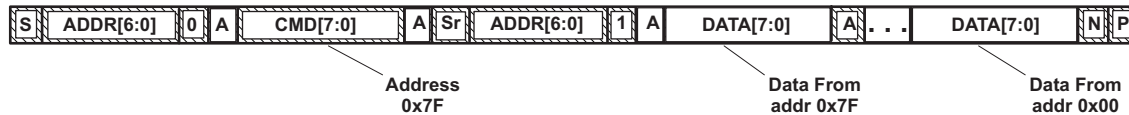

The I²C engine releases both SDA and SCL if the I²C bus is held low for $t_{(BUSERR)}$. If the fuel gauge was holding the lines, releasing them frees the master to drive the lines. If an external condition is holding either of the lines low, the I²C engine enters the low-power sleep mode.

9.8.3.1 I²C Time Out

The I²C engine will release both SDA and SCL if the I²C bus is held low for about 2 seconds. If the fuel gauge was holding the lines, releasing them will free for the master to drive the lines.

9.8.3.2 I²C Command Waiting Time

To make sure the correct results of a command with the 400-kHz I²C operation, a proper waiting time should be added between issuing command and reading results. For subcommands, the following diagram shows the waiting time required between issuing the control command the reading the status with the exception of the checksum command. A 100-ms waiting time is required between the checksum command and reading result. For read-write standard commands, a minimum of 2 seconds is required to get the result updated. For read-only standard commands, there is no waiting time required, but the host should not issue all standard commands more than two times per second. Otherwise, the gauge could result in a reset issue due to the expiration of the watchdog timer.



Waiting time between control subcommand and reading results

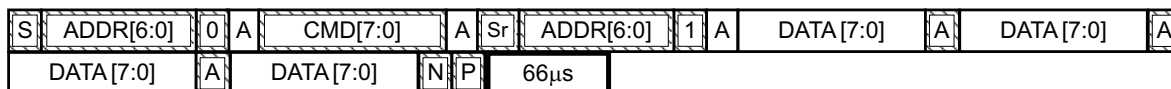

Waiting time between continuous reading results

Communications (continued)

9.8.3.3 I²C Clock Stretching

I²C clock stretches can occur during all modes of fuel gauge operation. In the SLEEP and HIBERNATE modes, a short clock stretch will occur on all I²C traffic as the device must wake-up to process the packet. In NORMAL and SLEEP+ modes, clock stretching will only occur for packets addressed for the fuel gauge. The timing of stretches will vary as interactions between the communicating host and the gauge are asynchronous. The I²C clock stretches may occur after start bits, the ACK/NAK bit and first data bit transmit on a host read cycle. The majority of clock stretch periods are small (≤ 4 ms) as the I²C interface peripheral and CPU firmware perform normal data flow control. However, less frequent but more significant clock stretch periods may occur when data flash (DF) is being written by the CPU to update the resistance (Ra) tables and other DF parameters such as Qmax. Due to the organization of DF, updates need to be written in data blocks consisting of multiple data bytes.

An Ra table update requires erasing a single page of DF, programming the updated Ra table and a flag. The potential I²C clock stretching time is 24 ms maximum. This includes 20-ms page erase and 2-ms row programming time ($\times 2$ rows). The Ra table updates occur during the discharge cycle and at up to 15 resistance grid points that occur during the discharge cycle.

A DF block write typically requires a maximum of 72 ms. This includes copying data to a temporary buffer and updating DF. This temporary buffer mechanism is used to protect from power failure during a DF update. The first part of the update requires 20 ms to erase the copy buffer page, 6 ms to write the data into the copy buffer and the program progress indicator (2 ms for each individual write). The second part of the update is writing to the DF and requires 44 ms for DF block update. This includes a 20-ms each page erase for two pages and 2-ms each row write for two rows.

In the event that a previous DF write was interrupted by a power failure or reset during the DF write, an additional 44-ms maximum DF restore time is required to recover the data from a previously interrupted DF write. In this power failure recovery case, the total I²C clock stretching is 116 ms maximum.

Another case where I²C clock stretches is at the end of discharge. The update to the last discharge data will go through the DF block update twice because two pages are used for the data storage. The clock stretching in this case is 144 ms maximum. This occurs if there has been a Ra table update during the discharge.

Typical Application (continued)

10.2.1 Design Requirements

Several key parameters must be updated to align with a given application's battery characteristics. For highest accuracy gauging, it is important to follow-up this initial configuration with a learning cycle to optimize resistance and maximum chemical capacity (Qmax) values prior to sealing and shipping packs to the field. Successful and accurate configuration of the fuel gauge for a target application can be used as the basis for creating a "golden" file that can be written to all production packs, assuming identical pack design and Li-Ion cell origin (chemistry, lot, and so forth). Calibration data can be included as part of this golden file to cut down on battery pack production time. If going this route, it is recommended to average the calibration data from a large sample size and use these in the golden file. Ideally, it is recommended to calibrate all packs individually as this will lead to the highest performance and lowest measurement error in the end application on a per-pack basis. In addition, the integrated protection functionality should be correctly configured to ensure activation based on the fault protection needs of the target pack design, or else accidental trip could be possible if using defaults. [Table 9](#), Key Data Flash Parameters for Configuration, shows the items that should be configured to achieve reliable protection and accurate gauging with minimal initial configuration.

Table 9. Key Data Flash Parameters for Configuration

NAME	DEFAULT	UNIT	RECOMMENDED SETTING
Design Capacity	1000	mAh	Set based on the nominal pack capacity as interpreted from cell manufacturer's datasheet. If multiple parallel cells are used, should be set to N × Cell Capacity.
Design Energy	3800	mWh	Set based on the nominal pack energy (nominal cell voltage × nominal cell capacity) as interpreted from the cell manufacturer's datasheet. If multiple parallel cells are used, should be set to N × Cell Energy.
Design Energy Scale	1	—	Set to 10 to convert all power values to cWh or to 1 for mWh. Design Energy is divided by this value.
Reserve Capacity	0	mAh	Set to desired runtime remaining (in seconds / 3600) × typical applied load between reporting 0% SOC and reaching Terminate Voltage , if needed.
Design Voltage	3800	mV	Set to nominal cell voltage per manufacturer datasheet.
Cycle Count Threshold	900	mAh	Set to 90% of configured Design Capacity
Device Chemistry	0354	hex	Should be configured using TI-supplied Battery Management Studio software. Default open-circuit voltage and resistance tables are also updated in conjunction with this step. Do not attempt to manually update reported Device Chemistry as this does not change all chemistry information! Always update chemistry using the appropriate software tool (that is, BMS).
Load Mode	1	—	Set to applicable load model, 0 for constant current or 1 for constant power.
Load Select	1	—	Set to load profile which most closely matches typical system load.
Qmax Cell 0	1000	mAh	Set to initial configured value for Design Capacity. The gauge will update this parameter automatically after the optimization cycle and for every regular Qmax update thereafter.
V at Chg Term	4350	mV	Set to nominal cell voltage for a fully charged cell. The gauge will update this parameter automatically each time full charge termination is detected.
Terminate Voltage	3000	mV	Set to empty point reference of battery based on system needs. Typical is between 3000 and 3200 mV.
Ra Max Delta	43	mΩ	Set to 15% of Cell0 R_a 4 resistance after an optimization cycle is completed.
Charging Voltage	4350	mV	Set based on nominal charge voltage for the battery in normal conditions (25°C, and so on). Used as the reference point for offsetting by Taper Voltage for full charge termination detection.
Taper Current	100	mA	Set to the nominal taper current of the charger + taper current tolerance to ensure that the gauge will reliably detect charge termination.
Taper Voltage	100	mV	Sets the voltage window for qualifying full charge termination. Can be set tighter to avoid or wider to ensure possibility of reporting 100% SOC in outer JEITA temperature ranges that use derated charging voltage.
Dsg Current Threshold	60	mA	Sets threshold for gauge detecting battery discharge. Should be set lower than minimal system load expected in the application and higher than Quit Current .
Chg Current Threshold	75	mA	Sets the threshold for detecting battery charge. Can be set higher or lower depending on typical trickle charge current used. Also should be set higher than Quit Current .

Typical Application (continued)
Table 9. Key Data Flash Parameters for Configuration (continued)

NAME	DEFAULT	UNIT	RECOMMENDED SETTING
Quit Current	40	mA	Sets threshold for gauge detecting battery relaxation. Can be set higher or lower depending on typical standby current and exhibited in the end system.
Avg I Last Run	-299	mA	Current profile used in capacity simulations at onset of discharge or at all times if Load Select = 0. Should be set to nominal system load. Is automatically updated by the gauge every cycle.
Avg P Last Run	-1131	mW	Power profile used in capacity simulations at onset of discharge or at all times if Load Select = 0. Should be set to nominal system power. Is automatically updated by the gauge every cycle.
Sleep Current	15	mA	Sets the threshold at which the fuel gauge enters SLEEP Mode. Take care in setting above typical standby currents else entry to SLEEP may be unintentionally blocked.
T1 Temp	0	°C	Sets the boundary between charging inhibit / suspend and charging with T1-T2 parameters. Defaults set based on recommended values from JEITA standard.
T2 Temp	10	°C	Sets the boundary between charging with T1-T2 or T2-T3 parameters. Defaults set based on recommended values from JEITA standard.
T3 Temp	45	°C	Sets the boundary between charging with T2-T3 or T3-T4 parameters. Defaults set based on recommended values from JEITA standard.
T4 Temp	50	°C	Sets the boundary between charging with T4-T5 or T4-T5 parameters. Also serves as charge inhibit boundary if initiating new charging event. Defaults set based on recommended values from JEITA standard.
T5 Temp	60	°C	Sets the boundary between charging suspend and charging with T4-T5 parameters. Refer to JEITA standard for compliance.
Temp Hys	1	°C	Adds temperature hysteresis for boundary crossings to avoid oscillation if temperature is changing by a degree, approximately, on a given boundary.
T1-T2 Chg Voltage	4350	mV	Sets reported charge voltage when inside of T1 Temp and T2 Temp range. Defaults set based on recommended values from JEITA standard.
T2-T3 Chg Voltage	4350	mV	Sets reported charge voltage when inside of T2 Temp and T3 Temp range. Defaults set based on recommended values from JEITA standard.
T3-T4 Chg Voltage	4300	mV	Sets reported charge voltage when inside of T3 Temp and T4 Temp range. Defaults set based on recommended values from JEITA standard.
T4-T5 Chg Voltage	4250	mV	Sets reported charge voltage when inside of T4 Temp and T5 Temp range. Defaults set based on recommended values from JEITA standard.
T1-T2 Chg Current	50	%	Sets reported charge current when inside of T1 Temp and T2 Temp range. Defaults set based on recommended values from JEITA standard.
T2-T3 Chg Current	80	%	Sets reported charge current when inside of T2 Temp and T3 Temp range. Defaults set based on recommended values from JEITA standard.
T3-T4 Chg Current	80	%	Sets reported charge current when inside of T3 Temp and T4 Temp range. Defaults set based on recommended values from JEITA standard.
T4-T5 Chg Current	80	%	Sets reported charge current when inside of T4 Temp and T5 Temp range. Defaults set based on recommended values from JEITA standard.
OT Chg	55.0	°C	Set to desired temperature at which charging is prohibited to prevent cell damage due to excessive ambient temperature.
OT Chg Time	5	s	Set to desired time before CHG FET is disabled based on overtemperature. Because temperature changes much more slowly than other fault conditions, the default setting is sufficient for most application.
OT Chg Recovery	50.0	°C	Set to the temperature threshold at which charging is no longer prohibited.
OT Dsg	60.0	°C	Set to desired temperature at which discharging is prohibited to prevent cell damage due to excessive ambient temperature.
OT Dsg Time	5	s	Set to desired time before DSG FET is disabled based on overtemperature. Because temperature changes much more slowly than other fault conditions, the default setting is sufficient for most application.
OT Dsg Recovery	55.0	°C	Set to the temperature threshold at which cell discharging is no longer prohibited.
CC Gain	5	mΩ	Calibrate this parameter using TI-supplied BMS software and calibration procedure in the TRM. Determines conversion of coulomb counter measured sense resistor voltage to current.

Typical Application (continued)

Table 9. Key Data Flash Parameters for Configuration (continued)

NAME	DEFAULT	UNIT	RECOMMENDED SETTING
CC Delta	5.074	mΩ	Calibrate this parameter using TI-supplied BMS software and calibration procedure in the TRM. Determines conversion of coulomb counter measured sense resistor voltage to passed charge.
CC Offset	6.874	mA	Calibrate this parameter using TI-supplied BMS software and calibration procedure in the TRM. Determines native offset of coulomb counter hardware that should be removed from conversions.
Board Offset	0.66	μA	Calibrate this parameter using TI-supplied BMS software and calibration procedure in the TRM. Determines native offset of the printed circuit board parasitics that should be removed from conversions.
Pack V Offset	0	mV	Calibrate this parameter using TI-supplied BMS software and calibration procedure in the TRM. Determines voltage offset between cell tab and ADC input node to incorporate back into or remove from measurement, depending on polarity.

10.2.2 Detailed Design Procedure

10.2.2.1 BAT Voltage Sense Input

A ceramic capacitor at the input to the BAT pin is used to bypass AC voltage ripple to ground, greatly reducing its influence on battery voltage measurements. It proves most effective in applications with load profiles that exhibit high frequency current pulses (that is, cell phones) but is recommended for use in all applications to reduce noise on this sensitive high impedance measurement node.

The series resistor between the battery and the BAT input is used to limit current that could be conducted through the chip-scale package's solder bumps in the event of an accidental short during the board assembly process. The resistor is not likely to survive a sustained short condition (depends on power rating); however, it sacrifices the much cheaper resistor component over suffering damage to the fuel gauge die itself.

10.2.2.2 SRP and SRN Current Sense Inputs

The filter network at the input to the coulomb counter is intended to improve differential mode rejection of voltage measured across the sense resistor. These components should be placed as close as possible to the coulomb counter inputs and the routing of the differential traces length-matched in order to best minimize impedance mismatch-induced measurement errors. The single-ended ceramic capacitors should be tied to the battery voltage node (preferably to a large copper pour connected to the SRN side of the sense resistor) in order to further improve common-mode noise rejection. The series resistors between the CC inputs and the sense resistor should be at least 200 Ω in order to mitigate SCR-induced latch-up due to possible ESD events.

10.2.2.3 Sense Resistor Selection

Any variation encountered in the resistance present between the SRP and SRN pins of the fuel gauge will affect the resulting differential voltage, and derived current, it senses. As such, it is recommended to select a sense resistor with minimal tolerance and temperature coefficient of resistance (TCR) characteristics. The standard recommendation based on best compromise between performance and price is a 1% tolerance, 50 ppm drift sense resistor with a 1-W power rating.

10.2.2.4 TS Temperature Sense Input

Similar to the BAT pin, a ceramic decoupling capacitor for the TS pin is used to bypass AC voltage ripple away from the high-impedance ADC input, minimizing measurement error. Another helpful advantage is that the capacitor provides additional ESD protection since most thermistors are handled and manually soldered to the PCB as a separate step in the factory production flow. As before, it should be placed as close as possible to the respective input pin for optimal filtering performance.

10.2.2.5 Thermistor Selection

The fuel gauge temperature sensing circuitry is designed to work with a negative temperature coefficient-type (NTC) thermistor with a characteristic 10-k Ω resistance at room temperature (25°C). The default curve-fitting coefficients configured in the fuel gauge specifically assume a 103AT-2 type thermistor profile and so that is the default recommendation for thermistor selection purposes. Moving to a separate thermistor resistance profile (for example, JT-2 or others) requires an update to the default thermistor coefficients in data flash to ensure highest accuracy temperature measurement performance.

10.2.2.6 REGIN Power Supply Input Filtering

A ceramic capacitor is placed at the input to the fuel gauge's internal LDO in order to increase power supply rejection (PSR) and improve effective line regulation. It ensures that voltage ripple is rejected to ground instead of coupling into the device's internal supply rails.

10.2.2.7 REG25 LDO Output Filtering

A ceramic capacitor is also needed at the output of the internal LDO in order to provide a current reservoir for fuel gauge load peaks during high peripheral utilization. It acts to stabilize the regulator output and reduce core voltage ripple inside of the device.

10.2.2.8 Communication Interface Lines

A protection network composed of resistors and zener diodes is recommended on each of the serial communication inputs to protect the fuel gauge from dangerous ESD transients. The Zener should be selected to break down at a voltage larger than the typical pullup voltage for these lines but less than the internal diode clamp breakdown voltage of the device inputs (~6 V). A zener voltage of 5.6 V is typically recommended. The series resistors are used to limit the current into the Zener diode and prevent component destruction due to thermal strain once it goes into breakdown. 100 Ω is typically recommended for these resistance values.

10.2.2.9 PACKP Voltage Sense Input

Inclusion of a 2-k Ω series resistor on the PACKP input allows it to tolerate a charger overvoltage event up to 28 V without device damage. The resistor also protects the device in the event of a reverse polarity charger input, since the substrate diode will be forward biased and attempt to conduct charger current through the fuel gauge (as well as the high FETs). An external reverse charger input FET clamp can be added to short the DSG FET gate to its source terminal, forcing the conduction channel off when negative voltage is present at PACK+ input to the battery pack and preventing large battery discharge currents. A ceramic capacitor connected at the PACKP pin helps to filter voltage into the comparator sense lines used for checking charger and load presence. In addition, in the Low Voltage Charging State, the minimal circuit elements that are operational are powered from this input pin and require a stable supply.

10.3 Application Curves

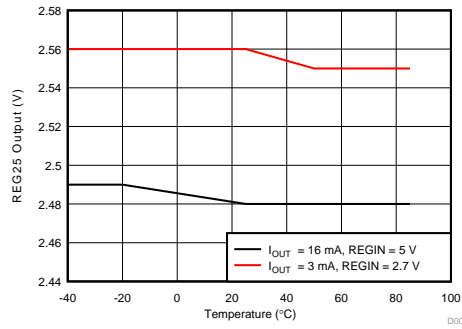

Figure 9. REG25 vs. Temperature

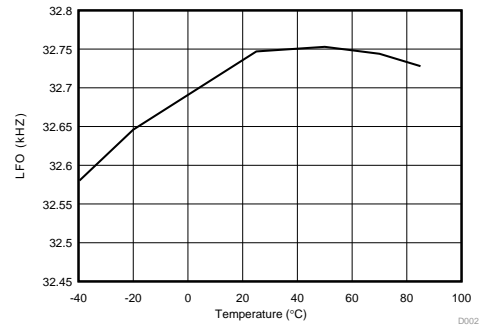

Figure 10. Low Frequency Oscillator vs. Temperature

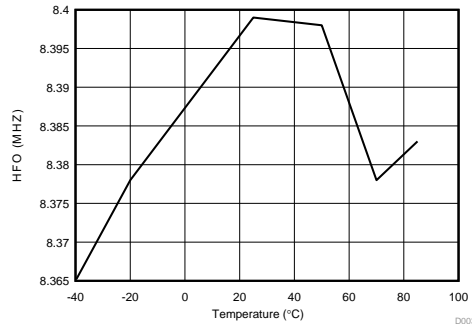

Figure 11. High Frequency Oscillator vs. Temperature

11 Power Supply Recommendations

The REGIN input pin and the REG25 output pin require low equivalent series resistance (ESR) ceramic capacitors placed as closely as possible to the respective pins to optimize ripple rejection and provide a stable and dependable power rail that is resilient to line transients. A 0.1- μ F capacitor at the REGIN and a 0.47- μ F capacitor at REG25 will suffice for satisfactory device performance.

12 Layout

12.1 Layout Guidelines

12.1.1 Lithium-Ion Cell Connections

For highest voltage measurement accuracy, it is critical to connect the BAT pin directly to the battery terminal PCB pad. This avoids measurement errors caused by IR drops when high charge or discharge currents are flowing. Connecting right at the positive battery terminal with a Kelvin connection ensures the elimination of parasitic resistance between the point of measurement and the actual battery terminal. Likewise the low current ground return for the fuel gauge and all related passive components should be star-connected right at the negative battery terminal. This technique minimizes measurement error due to current-induced ground offsets and also improves noise performance through prevention of ground bounce that could occur with high current and low current returns intersecting ahead of the battery ground. The bypass capacitor for this sense line needs to be placed as close as possible to the BAT input pin.

12.1.2 Sense Resistor Connections

Kelvin connections at the sense resistor are just as critical as those for the battery terminals themselves. The differential traces should be connected at the inside of the sense resistor pads and not anywhere along the high current trace path in order to prevent false increases to measured current that could result when measuring between the sum of the sense resistor and trace resistance between the tap points. In addition, the routing of these leads from the sense resistor to the input filter network and finally into the SRP and SRN pins needs to be as closely matched in length as possible else additional measurement offset could occur. It is further recommended to add copper trace or pour-based "guard rings" around the perimeter of the filter network and coulomb counter inputs to shield these sensitive pins from radiated EMI into the sense nodes. This prevents differential voltage shifts that could be interpreted as real current change to the fuel gauge. All of the filter components need to be placed as close as possible to the coulomb counter input pins.

12.1.3 Thermistor Connections

The thermistor sense input should include a ceramic bypass capacitor placed as close to the TS input pin as possible. The capacitor helps to filter measurements of any stray transients as the voltage bias circuit pulses periodically during temperature sensing windows.

12.1.4 High Current and Low Current Path Separation

For best possible noise performance, it is extremely important to separate the low current and high current loops to different areas of the board layout. The fuel gauge and all support components should be situated on one side of the boards and tap off of the high current loop (for measurement purposes) at the sense resistor. Routing the low current ground around instead of under high current traces will further help to improve noise rejection.

12.2 Layout Example

Battery Pack

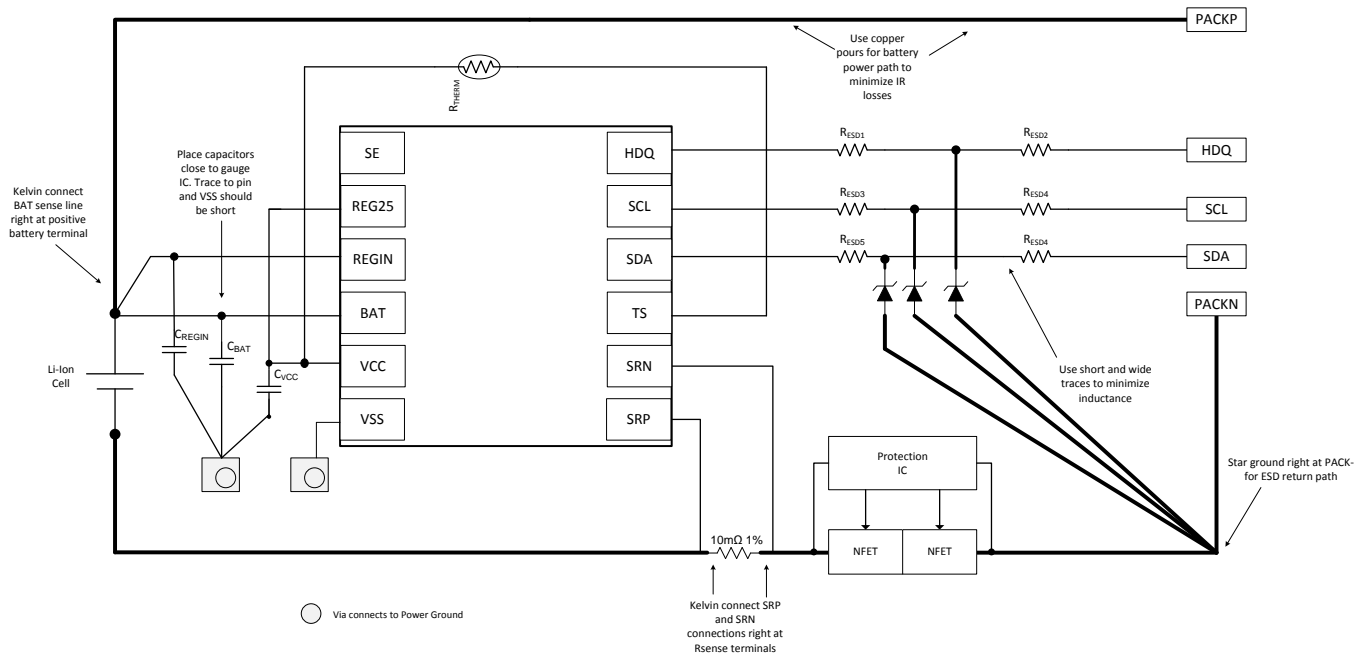

Figure 12. Layout Example

13 Device and Documentation Support

13.1 Documentation Support

13.1.1 Related Documentation

For related documentation, see the following:

- *bq27542-G1 Technical Reference Manual* ([SLUUB65](#))
- *IC Package Thermal Metrics* ([SPRA953](#))
- *Theory and Implementation of Impedance Track Battery Fuel-Gauging Algorithm Application Report* ([SLUA450](#))

13.2 Community Resources

The following links connect to TI community resources. Linked contents are provided "AS IS" by the respective contributors. They do not constitute TI specifications and do not necessarily reflect TI's views; see TI's [Terms of Use](#).

TI E2E™ Online Community *TI's Engineer-to-Engineer (E2E) Community*. Created to foster collaboration among engineers. At e2e.ti.com, you can ask questions, share knowledge, explore ideas and help solve problems with fellow engineers.

Design Support *TI's Design Support* Quickly find helpful E2E forums along with design support tools and contact information for technical support.

13.3 Trademarks

Impedance Track, E2E are trademarks of Texas Instruments.
All other trademarks are the property of their respective owners.

13.4 Electrostatic Discharge Caution



This integrated circuit can be damaged by ESD. Texas Instruments recommends that all integrated circuits be handled with appropriate precautions. Failure to observe proper handling and installation procedures can cause damage.

ESD damage can range from subtle performance degradation to complete device failure. Precision integrated circuits may be more susceptible to damage because very small parametric changes could cause the device not to meet its published specifications.

13.5 Glossary

[SLYZ022](#) — *TI Glossary*.

This glossary lists and explains terms, acronyms, and definitions.

14 Mechanical, Packaging, and Orderable Information

The following pages include mechanical, packaging, and orderable information. This information is the most current data available for the designated devices. This data is subject to change without notice and revision of this document. For browser-based versions of this data sheet, refer to the left-hand navigation.

PACKAGING INFORMATION

Orderable Device	Status (1)	Package Type	Package Drawing	Pins	Package Qty	Eco Plan (2)	Lead/Ball Finish (6)	MSL Peak Temp (3)	Op Temp (°C)	Device Marking (4/5)	Samples
BQ27542DRZR-G1	ACTIVE	SON	DRZ	12	3000	Green (RoHS & no Sb/Br)	CU NIPDAU	Level-2-260C-1 YEAR	-40 to 85	BQ 7542	Samples
BQ27542DRZT-G1	ACTIVE	SON	DRZ	12	250	Green (RoHS & no Sb/Br)	CU NIPDAU	Level-2-260C-1 YEAR	-40 to 85	BQ 7542	Samples

(1) The marketing status values are defined as follows:

ACTIVE: Product device recommended for new designs.

LIFEBUY: TI has announced that the device will be discontinued, and a lifetime-buy period is in effect.

NRND: Not recommended for new designs. Device is in production to support existing customers, but TI does not recommend using this part in a new design.

PREVIEW: Device has been announced but is not in production. Samples may or may not be available.

OBSELETE: TI has discontinued the production of the device.

(2) Eco Plan - The planned eco-friendly classification: Pb-Free (RoHS), Pb-Free (RoHS Exempt), or Green (RoHS & no Sb/Br) - please check <http://www.ti.com/productcontent> for the latest availability information and additional product content details.

TBD: The Pb-Free/Green conversion plan has not been defined.

Pb-Free (RoHS): TI's terms "Lead-Free" or "Pb-Free" mean semiconductor products that are compatible with the current RoHS requirements for all 6 substances, including the requirement that lead not exceed 0.1% by weight in homogeneous materials. Where designed to be soldered at high temperatures, TI Pb-Free products are suitable for use in specified lead-free processes.

Pb-Free (RoHS Exempt): This component has a RoHS exemption for either 1) lead-based flip-chip solder bumps used between the die and package, or 2) lead-based die adhesive used between the die and leadframe. The component is otherwise considered Pb-Free (RoHS compatible) as defined above.

Green (RoHS & no Sb/Br): TI defines "Green" to mean Pb-Free (RoHS compatible), and free of Bromine (Br) and Antimony (Sb) based flame retardants (Br or Sb do not exceed 0.1% by weight in homogeneous material)

(3) MSL, Peak Temp. - The Moisture Sensitivity Level rating according to the JEDEC industry standard classifications, and peak solder temperature.

(4) There may be additional marking, which relates to the logo, the lot trace code information, or the environmental category on the device.

(5) Multiple Device Markings will be inside parentheses. Only one Device Marking contained in parentheses and separated by a "~" will appear on a device. If a line is indented then it is a continuation of the previous line and the two combined represent the entire Device Marking for that device.

(6) Lead/Ball Finish - Orderable Devices may have multiple material finish options. Finish options are separated by a vertical ruled line. Lead/Ball Finish values may wrap to two lines if the finish value exceeds the maximum column width.

Important Information and Disclaimer: The information provided on this page represents TI's knowledge and belief as of the date that it is provided. TI bases its knowledge and belief on information provided by third parties, and makes no representation or warranty as to the accuracy of such information. Efforts are underway to better integrate information from third parties. TI has taken and continues to take reasonable steps to provide representative and accurate information but may not have conducted destructive testing or chemical analysis on incoming materials and chemicals. TI and TI suppliers consider certain information to be proprietary, and thus CAS numbers and other limited information may not be available for release.

In no event shall TI's liability arising out of such information exceed the total purchase price of the TI part(s) at issue in this document sold by TI to Customer on an annual basis.

TAPE AND REEL INFORMATION



QUADRANT ASSIGNMENTS FOR PIN 1 ORIENTATION IN TAPE



*All dimensions are nominal

Device	Package Type	Package Drawing	Pins	SPQ	Reel Diameter (mm)	Reel Width W1 (mm)	A0 (mm)	B0 (mm)	K0 (mm)	P1 (mm)	W (mm)	Pin1 Quadrant
BQ27542DRZR-G1	SON	DRZ	12	3000	330.0	12.4	2.8	4.3	1.2	4.0	12.0	Q2
BQ27542DRZT-G1	SON	DRZ	12	250	180.0	12.4	2.8	4.3	1.2	4.0	12.0	Q2

TAPE AND REEL BOX DIMENSIONS

*All dimensions are nominal

Device	Package Type	Package Drawing	Pins	SPQ	Length (mm)	Width (mm)	Height (mm)
BQ27542DRZR-G1	SON	DRZ	12	3000	552.0	367.0	36.0
BQ27542DRZT-G1	SON	DRZ	12	250	552.0	185.0	36.0

DRZ (R-PDSO-N12)

PLASTIC SMALL OUTLINE NO-LEAD

THERMAL INFORMATION

This package incorporates an exposed thermal pad that is designed to be attached directly to an external heatsink. The thermal pad must be soldered directly to the printed circuit board (PCB). After soldering, the PCB can be used as a heatsink. In addition, through the use of thermal vias, the thermal pad can be attached directly to the appropriate copper plane shown in the electrical schematic for the device, or alternatively, can be attached to a special heatsink structure designed into the PCB. This design optimizes the heat transfer from the integrated circuit (IC).

For information on the Quad Flatpack No-Lead (QFN) package and its advantages, refer to Application Report, QFN/SON PCB Attachment, Texas Instruments Literature No. SLUA271. This document is available at www.ti.com.

The exposed thermal pad dimensions for this package are shown in the following illustration.

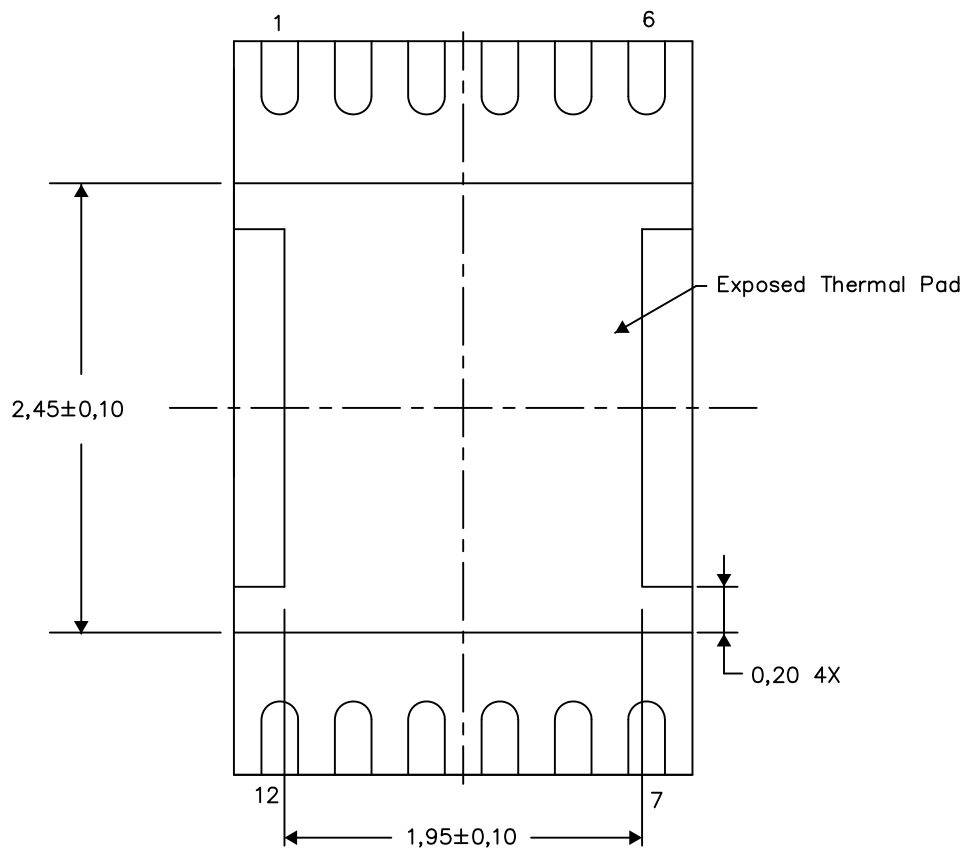

Bottom View
Exposed Thermal Pad Dimensions

4208114/F 10/14

NOTE: All linear dimensions are in millimeters

DRZ (S-PDSO-N12)

PLASTIC SMALL OUTLINE NO-LEAD

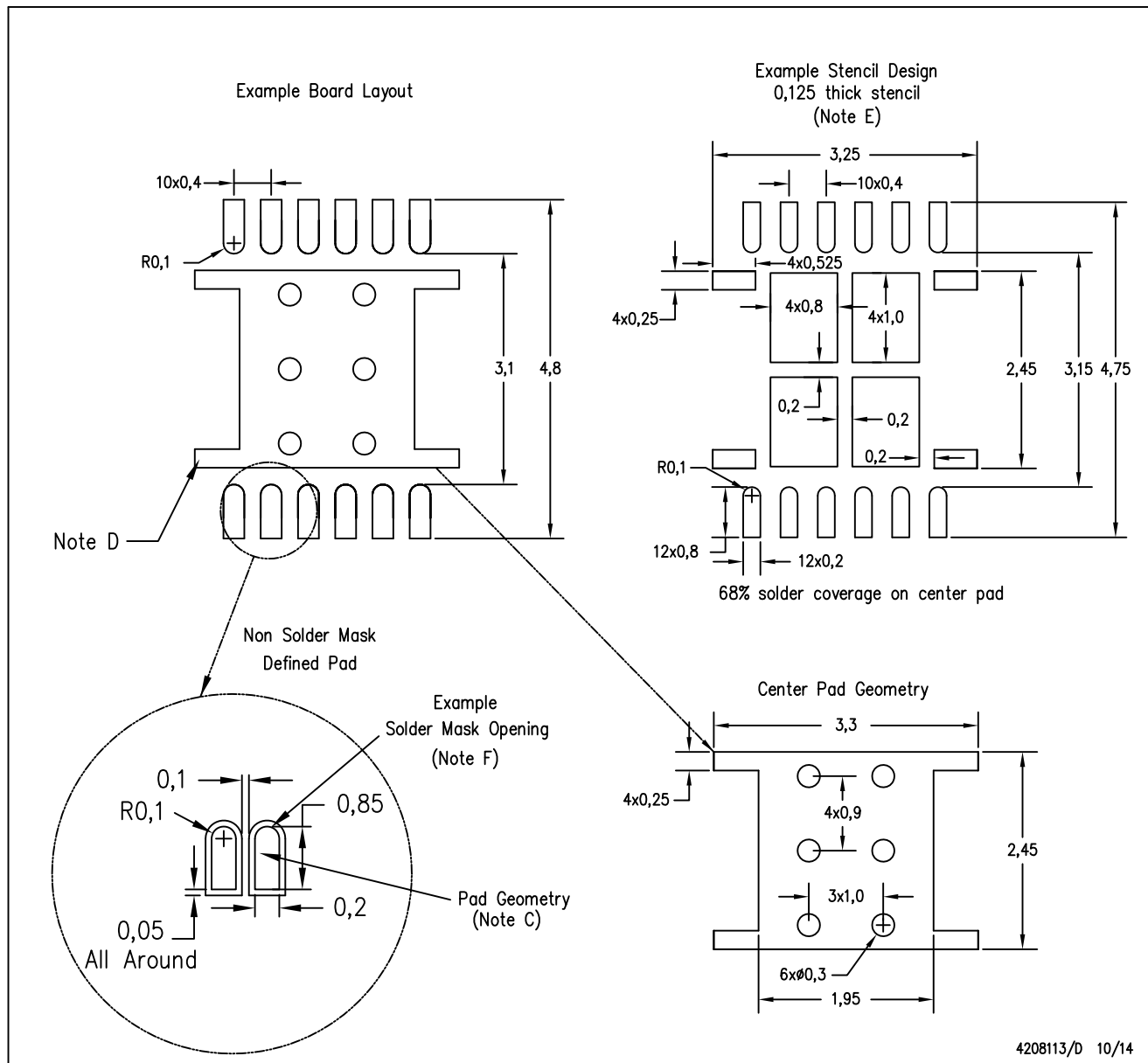

- NOTES:
- All linear dimensions are in millimeters.
 - This drawing is subject to change without notice.
 - Publication IPC-7351 is recommended for alternate designs.
 - This package is designed to be soldered to a thermal pad on the board. Refer to Application Note, Quad Flat-Pack Packages, Texas Instruments Literature No. SCBA017, SLUA271, and also the Product Data Sheets for specific thermal information, via requirements, and recommended board layout. These documents are available at www.ti.com <<http://www.ti.com>>.
 - Laser cutting apertures with trapezoidal walls and also rounding corners will offer better paste release. Customers should contact their board assembly site for stencil design recommendations. Refer to IPC 7525 for stencil design considerations.
 - Customers should contact their board fabrication site for minimum solder mask web tolerances between signal pads.

IMPORTANT NOTICE AND DISCLAIMER

TI PROVIDES TECHNICAL AND RELIABILITY DATA (INCLUDING DATASHEETS), DESIGN RESOURCES (INCLUDING REFERENCE DESIGNS), APPLICATION OR OTHER DESIGN ADVICE, WEB TOOLS, SAFETY INFORMATION, AND OTHER RESOURCES "AS IS" AND WITH ALL FAULTS, AND DISCLAIMS ALL WARRANTIES, EXPRESS AND IMPLIED, INCLUDING WITHOUT LIMITATION ANY IMPLIED WARRANTIES OF MERCHANTABILITY, FITNESS FOR A PARTICULAR PURPOSE OR NON-INFRINGEMENT OF THIRD PARTY INTELLECTUAL PROPERTY RIGHTS.

These resources are intended for skilled developers designing with TI products. You are solely responsible for (1) selecting the appropriate TI products for your application, (2) designing, validating and testing your application, and (3) ensuring your application meets applicable standards, and any other safety, security, or other requirements. These resources are subject to change without notice. TI grants you permission to use these resources only for development of an application that uses the TI products described in the resource. Other reproduction and display of these resources is prohibited. No license is granted to any other TI intellectual property right or to any third party intellectual property right. TI disclaims responsibility for, and you will fully indemnify TI and its representatives against, any claims, damages, costs, losses, and liabilities arising out of your use of these resources.

TI's products are provided subject to TI's Terms of Sale (www.ti.com/legal/termsofsale.html) or other applicable terms available either on ti.com or provided in conjunction with such TI products. TI's provision of these resources does not expand or otherwise alter TI's applicable warranties or warranty disclaimers for TI products.

Mailing Address: Texas Instruments, Post Office Box 655303, Dallas, Texas 75265
Copyright © 2019, Texas Instruments Incorporated

Looking for pricing, stock, or lifecycle information?

Click below to explore more details on WIN SOURCE:

 [View BQ27542DRZR-G1 on WIN SOURCE](#)

 [Texas Instruments](#) Information

Optimize Your Supply Chain with WIN SOURCE Solutions

-  Global Sourcing Solution
-  Obsolete Management
-  Cost Control Management
-  Shortage Management
-  Alternative Solution
-  Excess Inventory Management