



**THE DATASHEET OF
SN74HC273NE4**



SNx4HC273 Octal D-Type Flip-Flops With Clear

1 Features

- Wide operating voltage range of 2 V to 6 V
- Outputs can drive up to 10 LSTTL loads
- Low power consumption, 80- μ A maximum I_{CC}
- Typical $t_{pd} = 12$ ns
- ± 4 -mA output drive at 5 V
- Low input current of 1- μ A maximum
- Contain eight flip-flops with single-rail outputs
- Direct clear input
- Individual data input to each flip-flop
- On products compliant to MIL-PRF-38535, all parameters are tested unless otherwise noted. On all other products, production processing does not necessarily include testing of all parameters.

2 Applications

- Buffer or storage registers
- Shift registers
- Pattern generators

3 Description

The SNx4HC273 devices are positive-edge-triggered D-type flip-flops with a direct active low clear (\overline{CLR}) input.

Information at the data (D) inputs meeting the setup time requirements is transferred to the Q outputs on the positive-going edge of the clock (CLK) pulse. Clock triggering occurs at a particular voltage level and is not related directly to the transition time of the positive-going pulse. When CLK is at either the high or low level, the D input has no effect at the output.

Device Information⁽¹⁾

PART NUMBER	PACKAGE (PINS)	BODY SIZE (NOM)
SN54HC273J	CDIP (20)	24.20 mm \times 6.92 mm
SN54HC273W	CFP (20)	13.09 mm \times 6.92 mm
SN54HC273FK	LCCC (20)	8.89 mm \times 8.89 mm
SN74HC273D	SOIC (20)	12.80 mm \times 7.50 mm
SN74HC273DB	SSOP (20)	7.20 mm \times 5.30 mm
SN74HC273NS	SO (20)	12.60 mm \times 5.30 mm
SN74HC273N	PDIP (20)	24.33 mm \times 6.35 mm
SN74HC273PW	TSSOP (20)	6.50 mm \times 4.40 mm

(1) For all available packages, see the orderable addendum at the end of the data sheet.

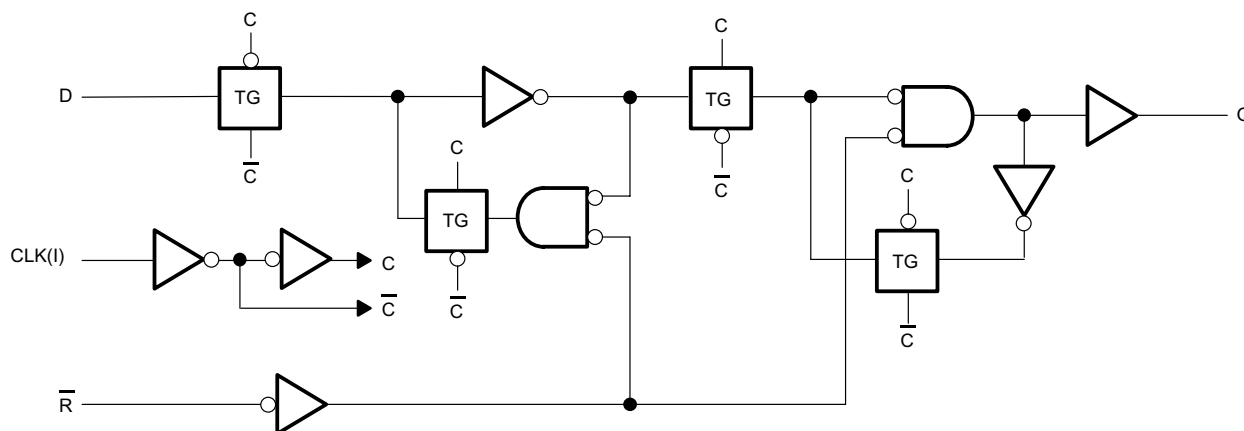

Copyright © 2016, Texas Instruments Incorporated

Functional Block Diagram



Table of Contents

1 Features	1	8 Detailed Description	11
2 Applications	1	8.1 Overview.....	11
3 Description	1	8.2 Functional Block Diagram.....	11
4 Revision History	2	8.3 Feature Description.....	11
5 Pin Configuration and Functions	3	8.4 Device Functional Modes.....	11
6 Specifications	4	9 Application and Implementation	12
6.1 Absolute Maximum Ratings.....	4	9.1 Application Information.....	12
6.2 ESD Ratings – SN74HC273.....	4	9.2 Typical Application.....	12
6.3 Recommended Operating Conditions.....	4	10 Power Supply Recommendations	14
6.4 Thermal Information.....	5	11 Layout	14
6.5 Electrical Characteristics.....	5	11.1 Layout Guidelines.....	14
6.6 Electrical Characteristics – SN54HC273.....	5	11.2 Layout Example.....	14
6.7 Electrical Characteristics – SN74HC273.....	6	12 Device and Documentation Support	15
6.8 Timing Requirements.....	6	12.1 Documentation Support.....	15
6.9 Timing Requirements – SN54HC273.....	7	12.2 Related Links.....	15
6.10 Timing Requirements – SN74HC273.....	7	12.3 Receiving Notification of Documentation Updates.....	15
6.11 Switching Characteristics.....	8	12.4 Support Resources.....	15
6.12 Switching Characteristics – SN54HC273.....	8	12.5 Trademarks.....	15
6.13 Switching Characteristics – SN74HC273.....	8	12.6 Electrostatic Discharge Caution.....	15
6.14 Operating Characteristics.....	9	12.7 Glossary.....	15
6.15 Typical Characteristics.....	9	13 Mechanical, Packaging, and Orderable Information	15
7 Parameter Measurement Information	10		

4 Revision History

NOTE: Page numbers for previous revisions may differ from page numbers in the current version.

Changes from Revision E (August 2003) to Revision F (April 2022)	Page
• Updated the ESD ratings table to fit modern standards.....	4
• Changed package thermal impedance, $R_{\theta JA}$, values from: 90.3 to: 122.7 (DB), from: 77.4 to: 109.1 (DW), from: 45.1 to: 84.6 (N), from: 72.6 to: 113.4 (NS), and from: 98.3 to: 131.8 (PW).....	5
• Updated Power Supply Recommendations and Layout Guidelines sections to include current TI terminology... 14	

Changes from Revision D (December 1982) to Revision E (July 2016)	Page
• Added <i>Device Information</i> table, <i>ESD Ratings</i> table, <i>Feature Description</i> section, <i>Device Functional Modes</i> , <i>Application and Implementation</i> section, <i>Power Supply Recommendations</i> section, <i>Layout</i> section, <i>Device and Documentation Support</i> section, and <i>Mechanical, Packaging, and Orderable Information</i> section.....	1
• Removed <i>Ordering Information</i> table, see POA at the end of the data sheet.....	1
• Added Military Disclaimer to <i>Features</i>	1

5 Pin Configuration and Functions

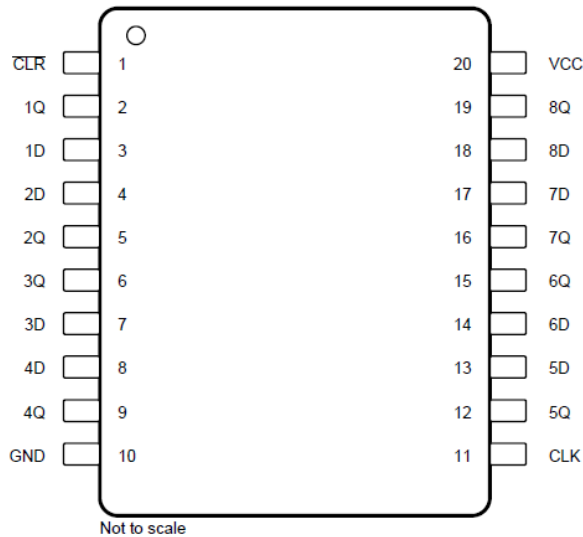

**J, W, DB, DW N, NS, or PW Package,
20-Pin CDIP, CFP, SSOP, SOIC, SO, PDIP, or TSSOP
(Top View)**

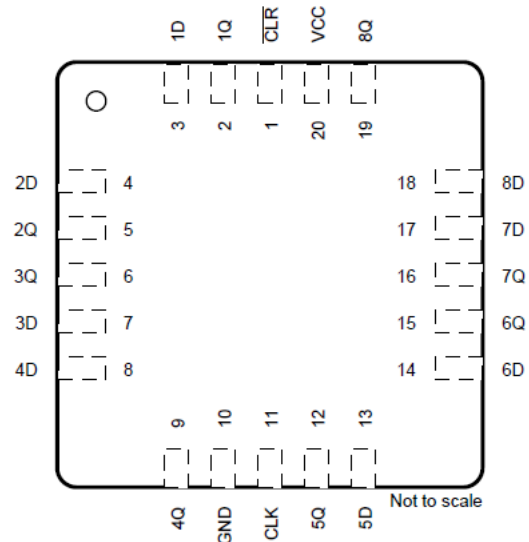

**FK Package,
20-Pin LCCC
(Top View)**

Table 5-1. Pin Functions

PIN		TYPE ⁽¹⁾	DESCRIPTION
NO.	NAME		
1	CLR	I	Active low clear input
2	1Q	O	Output 1
3	1D	I	Input 1
4	2D	I	Input 2
5	2Q	O	Output 2
6	3Q	O	Output 3
7	3D	I	Input 3
8	4D	I	Input 4
9	4Q	O	Output 4
10	GND	—	Ground
11	CLK	I	Clock input
12	5Q	O	Output 5
13	5D	I	Input 5
14	6D	I	Input 6
15	6Q	O	Output 6
16	7Q	O	Output 7
17	7D	I	Input 7
18	8D	I	Input 8
19	8Q	O	Output 8
20	V _{CC}	—	Power

(1) Signal Types: I = Input, O = Output, I/O = Input or Output.

6 Specifications

6.1 Absolute Maximum Ratings

over operating free-air temperature range (unless otherwise noted)⁽¹⁾

		MIN	MAX	UNIT
V _{CC}	Supply voltage	-0.5	7	V
I _{IK}	Input clamp current ⁽²⁾	V _I < 0 or V _I > V _{CC}		±20 mA
I _{OK}	Output clamp current ⁽²⁾	V _O < 0 or V _O > V _{CC}		±20 mA
I _O	Continuous output current	V _O = 0 to V _{CC}		±25 mA
	Continuous current through V _{CC} or GND			±50 mA
T _J	Junction temperature			150 °C
T _{stg}	Storage temperature	-65	150	°C

- (1) Stresses beyond those listed under *Absolute Maximum Ratings* may cause permanent damage to the device. These are stress ratings only, and functional operation of the device at these or any other conditions beyond those indicated under *Recommended Operating Conditions* is not implied. Exposure to absolute-maximum-rated conditions for extended periods may affect device reliability.
- (2) The input and output voltage ratings may be exceeded if the input and output current ratings are observed.

6.2 ESD Ratings – SN74HC273

		VALUE	UNIT
V _(ESD)	Electrostatic discharge	Human-body model (HBM), per ANSI/ESDA/JEDEC JS-001 ⁽¹⁾	±2000
		Charged device model (CDM), per ANSI/ESDA/JEDEC JS-002 ⁽²⁾	±500

- (1) JEDEC document JEP155 states that 500-V HBM allows safe manufacturing with a standard ESD control process. Manufacturing with less than 500-V HBM is possible with the necessary precautions.
- (2) JEDEC document JEP157 states that 250-V CDM allows safe manufacturing with a standard ESD control process. Manufacturing with less than 250-V CDM is possible with the necessary precautions.

6.3 Recommended Operating Conditions

over operating free-air temperature range (unless otherwise noted)⁽¹⁾

		MIN	NOM	MAX	UNIT
V _{CC}	Supply voltage	2	5	6	V
V _{IH}	High-level input voltage	V _{CC} = 2 V	1.5		V
		V _{CC} = 4.5 V	3.15		
		V _{CC} = 6 V	4.2		
V _{IL}	Low-level input voltage	V _{CC} = 2 V		0.5	V
		V _{CC} = 4.5 V		1.35	
		V _{CC} = 6 V		1.8	
V _I	Input voltage	0		V _{CC}	V
V _O	Output voltage	0		V _{CC}	V
Δt/Δv	Input transition rise and fall time	V _{CC} = 2 V		1000	ns
		V _{CC} = 4.5 V		500	
		V _{CC} = 6 V		400	
T _A	Operating free-air temperature	SN54HC273	-55	125	°C
		SN74HC273	-40	85	

- (1) All unused inputs of the device must be held at V_{CC} or GND to ensure proper device operation. Refer to the TI application report, [Implications of Slow or Floating CMOS Inputs](#).

6.4 Thermal Information

THERMAL METRIC		SN74HC273					UNIT
		DW (SOIC)	DB (SSOP)	N (PDIP)	NS (SO)	PW (TSSOP)	
		20 PINS	20 PINS	20 PINS	20 PINS	20 PINS	
R _{θJA}	Junction-to-ambient thermal resistance ⁽¹⁾	109.1	122.7	84.6	113.4	131.8	°C/W
R _{θJC (top)}	Junction-to-case (top) thermal resistance	76	81.6	72.5	78.6	72.2	°C/W
R _{θJB}	Junction-to-board thermal resistance	77.6	77.5	65.3	78.4	82.8	°C/W
Ψ _{JT}	Junction-to-top characterization parameter	51.5	46.1	55.3	47.1	21.5	°C/W
Ψ _{JB}	Junction-to-board characterization parameter	77.1	77.1	65.2	78.1	82.4	°C/W
R _{θJC(bot)}	Junction-to-case (bottom) thermal resistance	N/A	N/A	N/A	N/A	N/A	°C/W

(1) For more information about traditional and new thermal metrics, see [Semiconductor and IC Package Thermal Metrics](#).

6.5 Electrical Characteristics

T_A = 25°C (unless otherwise noted)

PARAMETER	TEST CONDITIONS		MIN	TYP	MAX	UNIT
V _{OH}	V _I = V _{IH} or V _{IL}	I _{OH} = -20 μA	V _{CC} = 2 V	1.9	1.998	V
			V _{CC} = 4.5 V	4.4	4.499	
			V _{CC} = 6 V	5.9	5.999	
		I _{OH} = -4 mA, V _{CC} = 4.5 V	3.98	4.3		
		I _{OH} = -5.2 mA, V _{CC} = 6 V	5.48	5.8		
V _{OL}	V _I = V _{IH} or V _{IL}	I _{OL} = 20 μA	V _{CC} = 2 V	0.002	0.1	V
			V _{CC} = 4.5 V	0.001	0.1	
			V _{CC} = 6 V	0.001	0.1	
		I _{OL} = 4 mA, V _{CC} = 4.5 V	0.17	0.26		
		I _{OL} = 5.2 mA, V _{CC} = 6 V	0.15	0.26		
I _I	V _I = V _{CC} or 0, V _{CC} = 6 V			±0.1	±100	nA
I _{CC}	V _I = V _{CC} or 0, I _O = 0, V _{CC} = 6 V				8	μA
C _i	V _{CC} = 2 V to 6 V			3	10	pF

6.6 Electrical Characteristics – SN54HC273

over recommended operating free-air temperature range (unless otherwise noted)

PARAMETER	TEST CONDITIONS		MIN	TYP	MAX	UNIT
V _{OH}	V _I = V _{IH} or V _{IL}	I _{OH} = -20 μA	V _{CC} = 2 V	1.9		V
			V _{CC} = 4.5 V	4.4		
			V _{CC} = 6 V	5.9		
		I _{OH} = -4 mA, V _{CC} = 4.5 V	3.7			
		I _{OH} = -5.2 mA, V _{CC} = 6 V	5.2			
V _{OL}	V _I = V _{IH} or V _{IL}	I _{OL} = 20 μA	V _{CC} = 2 V		0.1	V
			V _{CC} = 4.5 V		0.1	
			V _{CC} = 6 V		0.1	
		I _{OL} = 4 mA, V _{CC} = 4.5 V		0.4		
		I _{OL} = 5.2 mA, V _{CC} = V		0.4		
I _I	V _I = V _{CC} or 0, V _{CC} = 6 V				±1000	nA
I _{CC}	V _I = V _{CC} or 0, I _O = 0, V _{CC} = 6 V				160	μA

6.6 Electrical Characteristics – SN54HC273 (continued)

over recommended operating free-air temperature range (unless otherwise noted)

PARAMETER	TEST CONDITIONS	MIN	TYP	MAX	UNIT
C_i	$V_{CC} = 2\text{ V to }6\text{ V}$			10	pF

6.7 Electrical Characteristics – SN74HC273

over recommended operating free-air temperature range (unless otherwise noted)

PARAMETER	TEST CONDITIONS		MIN	TYP	MAX	UNIT
V_{OH}	$V_I = V_{IH}\text{ or }V_{IL}$	$I_{OH} = -20\ \mu\text{A}$	$V_{CC} = 2\text{ V}$		1.9	V
			$V_{CC} = 4.5\text{ V}$		4.4	
			$V_{CC} = 6\text{ V}$		5.9	
		$I_{OH} = -4\text{ mA}, V_{CC} = 4.5\text{ V}$			3.84	
		$I_{OH} = -5.2\text{ mA}, V_{CC} = 6\text{ V}$			5.34	
V_{OL}	$V_I = V_{IH}\text{ or }V_{IL}$	$I_{OL} = 20\ \mu\text{A}$	$V_{CC} = 2\text{ V}$		0.1	V
			$V_{CC} = 4.5\text{ V}$		0.1	
			$V_{CC} = 6\text{ V}$		0.1	
		$I_{OL} = 4\text{ mA}, V_{CC} = 4.5\text{ V}$			0.33	
		$I_{OL} = 5.2\text{ mA}, V_{CC} = 6\text{ V}$			0.33	
I_I	$V_I = V_{CC}\text{ or }0, V_{CC} = 6\text{ V}$				± 1000	nA
I_{CC}	$V_I = V_{CC}\text{ or }0, I_O = 0, V_{CC} = 6\text{ V}$				80	μA
C_i	$V_{CC} = 2\text{ V to }6\text{ V}$				10	pF

6.8 Timing Requirements

$T_A = 25^\circ\text{C}$ (unless otherwise noted)

		MIN	MAX	UNIT
f_{clock}	Clock frequency	$V_{CC} = 2\text{ V}$		5
		$V_{CC} = 4.5\text{ V}$		27
		$V_{CC} = 6\text{ V}$		32
t_w	$\overline{\text{CLR}}$ low	$V_{CC} = 2\text{ V}$	80	ns
		$V_{CC} = 4.5\text{ V}$	16	
		$V_{CC} = 6\text{ V}$	14	
	CLK high or low	$V_{CC} = 2\text{ V}$	80	
		$V_{CC} = 4.5\text{ V}$	16	
		$V_{CC} = 6\text{ V}$	14	
t_{su}	Data	$V_{CC} = 2\text{ V}$	100	ns
		$V_{CC} = 4.5\text{ V}$	20	
		$V_{CC} = 6\text{ V}$	17	
	$\overline{\text{CLR}}$ inactive	$V_{CC} = 2\text{ V}$	100	
		$V_{CC} = 4.5\text{ V}$	20	
		$V_{CC} = 6\text{ V}$	17	
t_h	Hold time, data after CLK \uparrow	$V_{CC} = 2\text{ V}$	0	ns
		$V_{CC} = 4.5\text{ V}$	0	
		$V_{CC} = 6\text{ V}$	0	

6.9 Timing Requirements – SN54HC273

over recommended operating free-air temperature range (unless otherwise noted)

		MIN	MAX	UNIT
f_{clock}	Clock frequency	$V_{\text{CC}} = 2\text{ V}$	4	MHz
		$V_{\text{CC}} = 4.5\text{ V}$	18	
		$V_{\text{CC}} = 6\text{ V}$	21	
t_{w}	CLR low	$V_{\text{CC}} = 2\text{ V}$	120	ns
		$V_{\text{CC}} = 4.5\text{ V}$	24	
		$V_{\text{CC}} = 6\text{ V}$	20	
	CLK high or low	$V_{\text{CC}} = 2\text{ V}$	120	
		$V_{\text{CC}} = 4.5\text{ V}$	24	
		$V_{\text{CC}} = 6\text{ V}$	20	
t_{su}	Data	$V_{\text{CC}} = 2\text{ V}$	150	ns
		$V_{\text{CC}} = 4.5\text{ V}$	30	
		$V_{\text{CC}} = 6\text{ V}$	25	
	CLR inactive	$V_{\text{CC}} = 2\text{ V}$	150	
		$V_{\text{CC}} = 4.5\text{ V}$	30	
		$V_{\text{CC}} = 6\text{ V}$	25	
t_{h}	Hold time, data after CLK \uparrow	$V_{\text{CC}} = 2\text{ V}$	0	ns
		$V_{\text{CC}} = 4.5\text{ V}$	0	
		$V_{\text{CC}} = 6\text{ V}$	0	

6.10 Timing Requirements – SN74HC273

over recommended operating free-air temperature range (unless otherwise noted)

		MIN	MAX	UNIT
f_{clock}	Clock frequency	$V_{\text{CC}} = 2\text{ V}$	4	MHz
		$V_{\text{CC}} = 4.5\text{ V}$	21	
		$V_{\text{CC}} = 6\text{ V}$	25	
t_{w}	CLR low	$V_{\text{CC}} = 2\text{ V}$	100	ns
		$V_{\text{CC}} = 4.5\text{ V}$	20	
		$V_{\text{CC}} = 6\text{ V}$	17	
	CLK high or low	$V_{\text{CC}} = 2\text{ V}$	100	
		$V_{\text{CC}} = 4.5\text{ V}$	20	
		$V_{\text{CC}} = 6\text{ V}$	17	
t_{su}	Data	$V_{\text{CC}} = 2\text{ V}$	125	ns
		$V_{\text{CC}} = 4.5\text{ V}$	25	
		$V_{\text{CC}} = 6\text{ V}$	21	
	CLR inactive	$V_{\text{CC}} = 2\text{ V}$	125	
		$V_{\text{CC}} = 4.5\text{ V}$	25	
		$V_{\text{CC}} = 6\text{ V}$	21	
t_{h}	Hold time, data after CLK \uparrow	$V_{\text{CC}} = 2\text{ V}$	0	ns
		$V_{\text{CC}} = 4.5\text{ V}$	0	
		$V_{\text{CC}} = 6\text{ V}$	0	

6.11 Switching Characteristics

$T_A = 25^\circ\text{C}$ and $C_L = 50\text{ pF}$ (unless otherwise noted; see [Figure 7-1](#))

PARAMETER	TEST CONDITIONS	MIN	TYP	MAX	UNIT	
f_{\max}		$V_{CC} = 2\text{ V}$	5	11	MHz	
		$V_{CC} = 4.5\text{ V}$	27	50		
		$V_{CC} = 6\text{ V}$	32	60		
t_{PHL}	From $\overline{\text{CLR}}$ (input) to any (output)	$V_{CC} = 2\text{ V}$		55	160	ns
		$V_{CC} = 4.5\text{ V}$		15	32	
		$V_{CC} = 6\text{ V}$		12	27	
t_{pd}	From CLK (input) to any (output)	$V_{CC} = 2\text{ V}$		56	160	ns
		$V_{CC} = 4.5\text{ V}$		15	32	
		$V_{CC} = 6\text{ V}$		13	27	
t_t	To any (output)	$V_{CC} = 2\text{ V}$		38	75	ns
		$V_{CC} = 4.5\text{ V}$		8	15	
		$V_{CC} = 6\text{ V}$		6	13	

6.12 Switching Characteristics – SN54HC273

over recommended operating free-air temperature range, $C_L = 50\text{ pF}$ (unless otherwise noted; see [Figure 7-1](#))

PARAMETER	TEST CONDITIONS	MIN	MAX	UNIT	
f_{\max}		$V_{CC} = 2\text{ V}$	4	MHz	
		$V_{CC} = 4.5\text{ V}$	18		
		$V_{CC} = 6\text{ V}$	21		
t_{PHL}	From $\overline{\text{CLR}}$ (input) to any (output)	$V_{CC} = 2\text{ V}$		240	ns
		$V_{CC} = 4.5\text{ V}$		48	
		$V_{CC} = 6\text{ V}$		41	
t_{pd}	From CLK (input) to any (output)	$V_{CC} = 2\text{ V}$		240	ns
		$V_{CC} = 4.5\text{ V}$		48	
		$V_{CC} = 6\text{ V}$		41	
t_t	To any (output)	$V_{CC} = 2\text{ V}$		110	ns
		$V_{CC} = 4.5\text{ V}$		22	
		$V_{CC} = 6\text{ V}$		19	

6.13 Switching Characteristics – SN74HC273

over recommended operating free-air temperature range, $C_L = 50\text{ pF}$ (unless otherwise noted; see [Figure 7-1](#))

PARAMETER	TEST CONDITIONS	MIN	MAX	UNIT	
f_{\max}		$V_{CC} = 2\text{ V}$	4	MHz	
		$V_{CC} = 4.5\text{ V}$	21		
		$V_{CC} = 6\text{ V}$	25		
t_{PHL}	From $\overline{\text{CLR}}$ (input) to any (output)	$V_{CC} = 2\text{ V}$		200	ns
		$V_{CC} = 4.5\text{ V}$		40	
		$V_{CC} = 6\text{ V}$		34	
t_{pd}	From CLK (input) to any (output)	$V_{CC} = 2\text{ V}$		200	ns
		$V_{CC} = 4.5\text{ V}$		40	
		$V_{CC} = 6\text{ V}$		34	

6.13 Switching Characteristics – SN74HC273 (continued)

over recommended operating free-air temperature range, $C_L = 50$ pF (unless otherwise noted; see Figure 7-1)

PARAMETER	TEST CONDITIONS	MIN	MAX	UNIT
t_t	To any (output)	$V_{CC} = 2$ V	95	ns
		$V_{CC} = 4.5$ V	19	
		$V_{CC} = 6$ V	16	

6.14 Operating Characteristics

$T_A = 25^\circ\text{C}$

PARAMETER	TEST CONDITIONS	TYP	UNIT
C_{pd} Power dissipation capacitance per flip-flop	No load	35	pF

6.15 Typical Characteristics

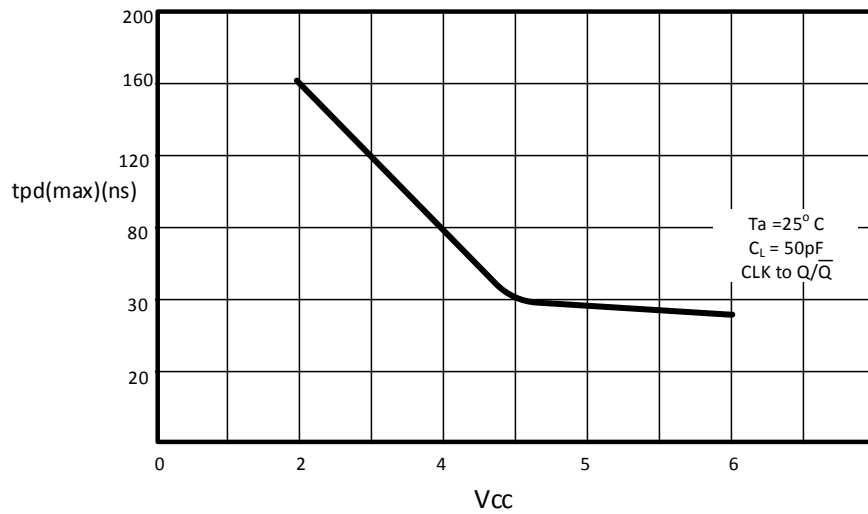
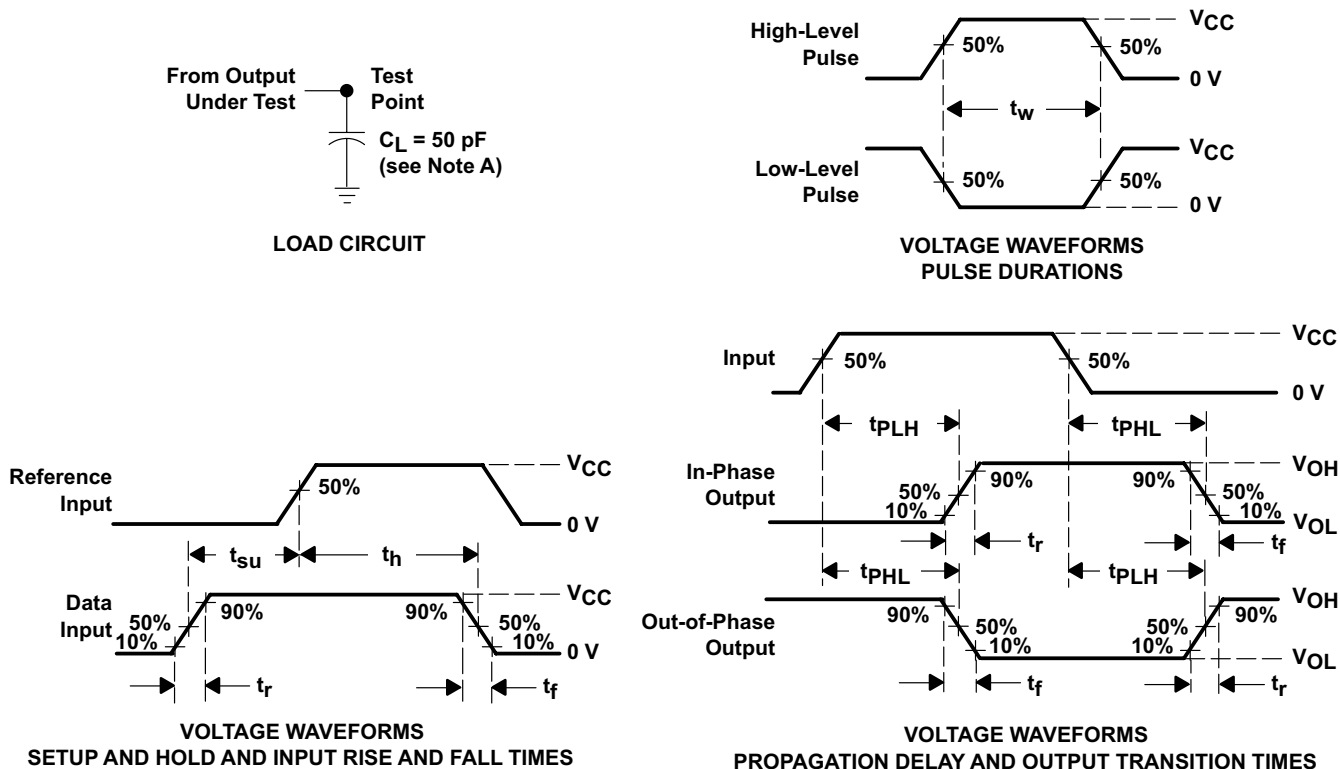

Figure 6-1. Max t_{pd} vs V_{CC}

7 Parameter Measurement Information



- NOTES:
- A. C_L includes probe and test-fixture capacitance.
 - B. Phase relationships between waveforms were chosen arbitrarily. All input pulses are supplied by generators having the following characteristics: $PRR \leq 1 \text{ MHz}$, $Z_O = 50 \Omega$, $t_r = 6 \text{ ns}$, $t_f = 6 \text{ ns}$.
 - C. For clock inputs, f_{max} is measured when the input duty cycle is 50%.
 - D. The outputs are measured one at a time with one input transition per measurement.
 - E. t_{PLH} and t_{PHL} are the same as t_{pd} .

Figure 7-1. Load Circuit and Voltage Waveforms

8 Detailed Description

8.1 Overview

The SNx4HC273 contains eight flip-flops with single-rail outputs with individual data input to each flip-flop. The outputs can drive up to 10 LSTTL loads. The device has direct active low clear input.

8.2 Functional Block Diagram

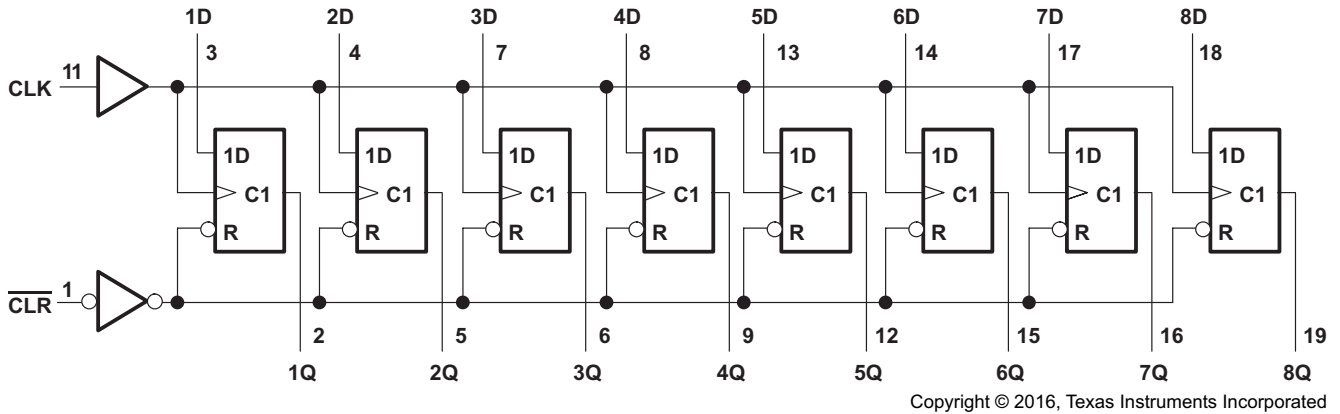

8.3 Feature Description

The SNx4HC273 has low power consumption with a maximum_{CC} of 80 μ A.

The typical t_{pd} for the SNx4HC273 is 12 ns and the output drive is ± 4 mA at 5 V.

The SNx4HC273 also has very low input current, with the maximum set at 1 μ A.

8.4 Device Functional Modes

Table 8-1 lists the functional modes of the SNx4HC273.

**Table 8-1. Function Table
(Each Flip-Flop)**

INPUTS			OUTPUT Q
CLR	CLK	D	
L	X	X	L
H	\uparrow	H	H
H	\uparrow	L	L
H	L	X	Q_0

9 Application and Implementation

Note

Information in the following applications sections is not part of the TI component specification, and TI does not warrant its accuracy or completeness. TI's customers are responsible for determining suitability of components for their purposes, as well as validating and testing their design implementation to confirm system functionality.

9.1 Application Information

The SNx4HC273 is octal D Flip flop with active low clear input. It has low input current and low power consumption. The D flip-flop can be used as a Toggle flip flop using an XOR gate at the input. The output toggles from the previous state whenever the T input is high.

9.2 Typical Application

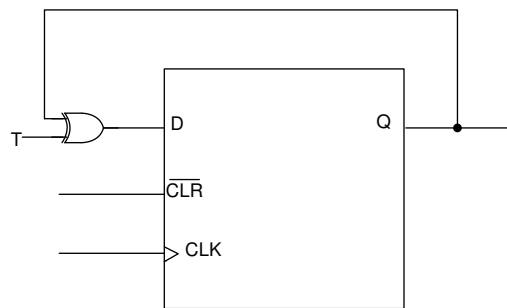

Copyright © 2016, Texas Instruments Incorporated

9.2.1 Design Requirements

This SNx4Hc273 device uses CMOS technology and has balanced output drive.

9.2.2 Detailed Design Procedure

- Recommended input conditions:
 - Rise time and fall time specifications: see $(\Delta t/\Delta V)$ in [Recommended Operating Conditions](#).
 - Specified high and low levels: see $(V_{IH}$ and $V_{IL})$ in [Recommended Operating Conditions](#).
 - Inputs are not overvoltage tolerant and must not be above any valid V_{CC} as per [Recommended Operating Conditions](#).
- Absolute maximum output conditions:
 - Continuous output currents must not exceed $(I_O \text{ max})$ per output and must not exceed total current (continuous current through V_{CC} or GND) for the part. These limits are located in the [Absolute Maximum Ratings](#).
 - Outputs must not be pulled above V_{CC} .

9.2.3 Application Curve

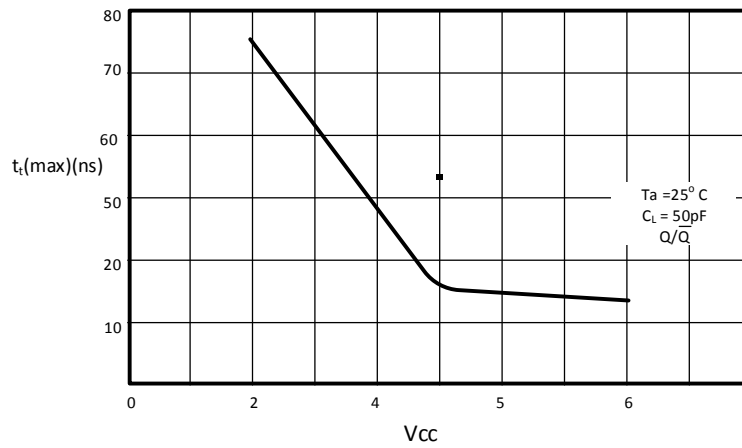

Figure 9-1. Maximum Transition Time vs V_{CC}

10 Power Supply Recommendations

The power supply can be any voltage between the minimum and maximum supply voltage rating located in the *Recommended Operating Conditions*. Each V_{CC} terminal should have a good bypass capacitor to prevent power disturbance. A 0.1- μF capacitor is recommended for this device. It is acceptable to parallel multiple bypass caps to reject different frequencies of noise. The 0.1- μF and 1- μF capacitors are commonly used in parallel. The bypass capacitor should be installed as close to the power terminal as possible for best results.

11 Layout

11.1 Layout Guidelines

When using multiple-input and multiple-channel logic devices inputs must not ever be left floating. In many cases, functions or parts of functions of digital logic devices are unused; for example, when only two inputs of a triple-input AND gate are used or only 3 of the 4 buffer gates are used. Such unused input pins must not be left unconnected because the undefined voltages at the outside connections result in undefined operational states. All unused inputs of digital logic devices must be connected to a logic high or logic low voltage, as defined by the input voltage specifications, to prevent them from floating. The logic level that must be applied to any particular unused input depends on the function of the device. Generally, the inputs are tied to GND or VCC, whichever makes more sense for the logic function or is more convenient.

11.2 Layout Example

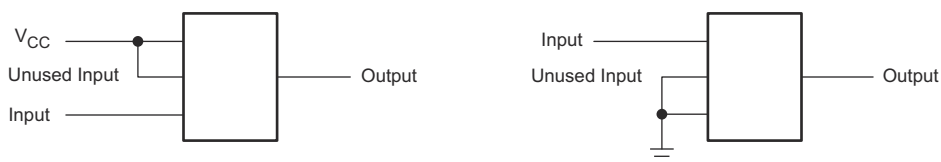

Figure 11-1. SNx4HC273 Layout

12 Device and Documentation Support

12.1 Documentation Support

12.1.1 Related Documentation

For related documentation, see the following:

- Texas Instruments, [Implications of Slow or Floating CMOS Inputs application report](#)

12.2 Related Links

The table below lists quick access links. Categories include technical documents, support and community resources, tools and software, and quick access to sample or buy.

Table 12-1. Related Links

PARTS	PRODUCT FOLDER	SAMPLE & BUY	TECHNICAL DOCUMENTS	TOOLS & SOFTWARE	SUPPORT & COMMUNITY
SN54HC273	Click here	Click here	Click here	Click here	Click here
SN74HC273	Click here	Click here	Click here	Click here	Click here

12.3 Receiving Notification of Documentation Updates

To receive notification of documentation updates, navigate to the device product folder on ti.com. In the upper right corner, click on *Alert me* to register and receive a weekly digest of any product information that has changed. For change details, review the revision history included in any revised document.

12.4 Support Resources

[TI E2E™ support forums](#) are an engineer's go-to source for fast, verified answers and design help — straight from the experts. Search existing answers or ask your own question to get the quick design help you need.

Linked content is provided "AS IS" by the respective contributors. They do not constitute TI specifications and do not necessarily reflect TI's views; see TI's [Terms of Use](#).

12.5 Trademarks

TI E2E™ is a trademark of Texas Instruments.

All trademarks are the property of their respective owners.

12.6 Electrostatic Discharge Caution



This integrated circuit can be damaged by ESD. Texas Instruments recommends that all integrated circuits be handled with appropriate precautions. Failure to observe proper handling and installation procedures can cause damage.

ESD damage can range from subtle performance degradation to complete device failure. Precision integrated circuits may be more susceptible to damage because very small parametric changes could cause the device not to meet its published specifications.

12.7 Glossary

[TI Glossary](#) This glossary lists and explains terms, acronyms, and definitions.

13 Mechanical, Packaging, and Orderable Information

The following pages include mechanical packaging and orderable information. This information is the most current data available for the designated devices. This data is subject to change without notice and revision of this document. For browser based versions of this data sheet, refer to the left hand navigation.

PACKAGING INFORMATION

Orderable Device	Status (1)	Package Type	Package Drawing	Pins	Package Qty	Eco Plan (2)	Lead finish/ Ball material (6)	MSL Peak Temp (3)	Op Temp (°C)	Device Marking (4/5)	Samples
5962-8409901VRA	ACTIVE	CDIP	J	20	20	Non-RoHS & Green	SNPB	N / A for Pkg Type	-55 to 125	5962-8409901VR A SNV54HC273J	Samples
5962-8409901VSA	ACTIVE	CFP	W	20	25	Non-RoHS & Green	SNPB	N / A for Pkg Type	-55 to 125	5962-8409901VS A SNV54HC273W	Samples
84099012A	ACTIVE	LCCC	FK	20	55	Non-RoHS & Green	SNPB	N / A for Pkg Type	-55 to 125	84099012A SNJ54HC 273FK	Samples
8409901RA	ACTIVE	CDIP	J	20	20	Non-RoHS & Green	SNPB	N / A for Pkg Type	-55 to 125	8409901RA SNJ54HC273J	Samples
8409901SA	ACTIVE	CFP	W	20	25	Non-RoHS & Green	SNPB	N / A for Pkg Type	-55 to 125	8409901SA SNJ54HC273W	Samples
JM38510/65601BRA	ACTIVE	CDIP	J	20	20	Non-RoHS & Green	SNPB	N / A for Pkg Type	-55 to 125	JM38510/ 65601BRA	Samples
JM38510/65601BSA	ACTIVE	CFP	W	20	25	Non-RoHS & Green	SNPB	N / A for Pkg Type	-55 to 125	JM38510/ 65601BSA	Samples
M38510/65601BRA	ACTIVE	CDIP	J	20	20	Non-RoHS & Green	SNPB	N / A for Pkg Type	-55 to 125	JM38510/ 65601BRA	Samples
M38510/65601BSA	ACTIVE	CFP	W	20	25	Non-RoHS & Green	SNPB	N / A for Pkg Type	-55 to 125	JM38510/ 65601BSA	Samples
SN54HC273J	ACTIVE	CDIP	J	20	20	Non-RoHS & Green	SNPB	N / A for Pkg Type	-55 to 125	SN54HC273J	Samples
SN74HC273DBR	ACTIVE	SSOP	DB	20	2000	RoHS & Green	NIPDAU	Level-1-260C-UNLIM	-40 to 85	HC273	Samples
SN74HC273DWR	ACTIVE	SOIC	DW	20	2000	RoHS & Green	NIPDAU	Level-1-260C-UNLIM	-40 to 85	HC273	Samples
SN74HC273DWRE4	ACTIVE	SOIC	DW	20	2000	RoHS & Green	NIPDAU	Level-1-260C-UNLIM	-40 to 85	HC273	Samples
SN74HC273DWRG4	ACTIVE	SOIC	DW	20	2000	RoHS & Green	NIPDAU	Level-1-260C-UNLIM	-40 to 85	HC273	Samples
SN74HC273N	ACTIVE	PDIP	N	20	20	RoHS & Green	NIPDAU	N / A for Pkg Type	-40 to 85	SN74HC273N	Samples
SN74HC273NE4	ACTIVE	PDIP	N	20	20	RoHS & Green	NIPDAU	N / A for Pkg Type	-40 to 85	SN74HC273N	Samples

Orderable Device	Status (1)	Package Type	Package Drawing	Pins	Package Qty	Eco Plan (2)	Lead finish/ Ball material (6)	MSL Peak Temp (3)	Op Temp (°C)	Device Marking (4/5)	Samples
SN74HC273NSR	ACTIVE	SO	NS	20	2000	RoHS & Green	NIPDAU	Level-1-260C-UNLIM	-40 to 85	HC273	Samples
SN74HC273PWR	ACTIVE	TSSOP	PW	20	2000	RoHS & Green	NIPDAU	Level-1-260C-UNLIM	-40 to 85	HC273	Samples
SN74HC273PWRG4	ACTIVE	TSSOP	PW	20	2000	RoHS & Green	NIPDAU	Level-1-260C-UNLIM	-40 to 85	HC273	Samples
SNJ54HC273FK	ACTIVE	LCCC	FK	20	55	Non-RoHS & Green	SNPB	N / A for Pkg Type	-55 to 125	84099012A SNJ54HC 273FK	Samples
SNJ54HC273J	ACTIVE	CDIP	J	20	20	Non-RoHS & Green	SNPB	N / A for Pkg Type	-55 to 125	8409901RA SNJ54HC273J	Samples
SNJ54HC273W	ACTIVE	CFP	W	20	25	Non-RoHS & Green	SNPB	N / A for Pkg Type	-55 to 125	8409901SA SNJ54HC273W	Samples

(1) The marketing status values are defined as follows:

ACTIVE: Product device recommended for new designs.

LIFEBUY: TI has announced that the device will be discontinued, and a lifetime-buy period is in effect.

NRND: Not recommended for new designs. Device is in production to support existing customers, but TI does not recommend using this part in a new design.

PREVIEW: Device has been announced but is not in production. Samples may or may not be available.

OBSELETE: TI has discontinued the production of the device.

(2) **RoHS:** TI defines "RoHS" to mean semiconductor products that are compliant with the current EU RoHS requirements for all 10 RoHS substances, including the requirement that RoHS substance do not exceed 0.1% by weight in homogeneous materials. Where designed to be soldered at high temperatures, "RoHS" products are suitable for use in specified lead-free processes. TI may reference these types of products as "Pb-Free".

RoHS Exempt: TI defines "RoHS Exempt" to mean products that contain lead but are compliant with EU RoHS pursuant to a specific EU RoHS exemption.

Green: TI defines "Green" to mean the content of Chlorine (Cl) and Bromine (Br) based flame retardants meet JS709B low halogen requirements of <=1000ppm threshold. Antimony trioxide based flame retardants must also meet the <=1000ppm threshold requirement.

(3) MSL, Peak Temp. - The Moisture Sensitivity Level rating according to the JEDEC industry standard classifications, and peak solder temperature.

(4) There may be additional marking, which relates to the logo, the lot trace code information, or the environmental category on the device.

(5) Multiple Device Markings will be inside parentheses. Only one Device Marking contained in parentheses and separated by a "-" will appear on a device. If a line is indented then it is a continuation of the previous line and the two combined represent the entire Device Marking for that device.

(6) Lead finish/Ball material - Orderable Devices may have multiple material finish options. Finish options are separated by a vertical ruled line. Lead finish/Ball material values may wrap to two lines if the finish value exceeds the maximum column width.

Important Information and Disclaimer: The information provided on this page represents TI's knowledge and belief as of the date that it is provided. TI bases its knowledge and belief on information provided by third parties, and makes no representation or warranty as to the accuracy of such information. Efforts are underway to better integrate information from third parties. TI has taken and continues to take reasonable steps to provide representative and accurate information but may not have conducted destructive testing or chemical analysis on incoming materials and chemicals. TI and TI suppliers consider certain information to be proprietary, and thus CAS numbers and other limited information may not be available for release.

In no event shall TI's liability arising out of such information exceed the total purchase price of the TI part(s) at issue in this document sold by TI to Customer on an annual basis.

OTHER QUALIFIED VERSIONS OF SN54HC273, SN54HC273-SP, SN74HC273 :

- Catalog : [SN74HC273](#), [SN54HC273](#)
- Automotive : [SN74HC273-Q1](#), [SN74HC273-Q1](#)
- Military : [SN54HC273](#)
- Space : [SN54HC273-SP](#)

NOTE: Qualified Version Definitions:

- Catalog - TI's standard catalog product
- Automotive - Q100 devices qualified for high-reliability automotive applications targeting zero defects
- Military - QML certified for Military and Defense Applications
- Space - Radiation tolerant, ceramic packaging and qualified for use in Space-based application

TAPE AND REEL INFORMATION

QUADRANT ASSIGNMENTS FOR PIN 1 ORIENTATION IN TAPE

*All dimensions are nominal

Device	Package Type	Package Drawing	Pins	SPQ	Reel Diameter (mm)	Reel Width W1 (mm)	A0 (mm)	B0 (mm)	K0 (mm)	P1 (mm)	W (mm)	Pin1 Quadrant
SN74HC273DBR	SSOP	DB	20	2000	330.0	16.4	8.2	7.5	2.5	12.0	16.0	Q1
SN74HC273DWR	SOIC	DW	20	2000	330.0	24.4	10.9	13.3	2.7	12.0	24.0	Q1
SN74HC273DWR	SOIC	DW	20	2000	330.0	24.4	10.9	13.3	2.7	12.0	24.0	Q1
SN74HC273DWRG4	SOIC	DW	20	2000	330.0	24.4	10.8	13.3	2.7	12.0	24.0	Q1
SN74HC273NSR	SO	NS	20	2000	330.0	24.4	8.4	13.0	2.5	12.0	24.0	Q1
SN74HC273NSR	SO	NS	20	2000	330.0	24.4	8.4	13.0	2.5	12.0	24.0	Q1
SN74HC273PWR	TSSOP	PW	20	2000	330.0	16.4	6.95	7.0	1.4	8.0	16.0	Q1
SN74HC273PWR	TSSOP	PW	20	2000	330.0	16.4	6.95	7.0	1.4	8.0	16.0	Q1

TAPE AND REEL BOX DIMENSIONS

*All dimensions are nominal

Device	Package Type	Package Drawing	Pins	SPQ	Length (mm)	Width (mm)	Height (mm)
SN74HC273DBR	SSOP	DB	20	2000	356.0	356.0	35.0
SN74HC273DWR	SOIC	DW	20	2000	367.0	367.0	45.0
SN74HC273DWR	SOIC	DW	20	2000	367.0	367.0	45.0
SN74HC273DWRG4	SOIC	DW	20	2000	367.0	367.0	45.0
SN74HC273NSR	SO	NS	20	2000	367.0	367.0	45.0
SN74HC273NSR	SO	NS	20	2000	367.0	367.0	45.0
SN74HC273PWR	TSSOP	PW	20	2000	356.0	356.0	35.0
SN74HC273PWR	TSSOP	PW	20	2000	356.0	356.0	35.0

TUBE

*All dimensions are nominal

Device	Package Name	Package Type	Pins	SPQ	L (mm)	W (mm)	T (μm)	B (mm)
5962-8409901VSA	W	CFP	20	25	506.98	26.16	6220	NA
84099012A	FK	LCCC	20	55	506.98	12.06	2030	NA
8409901SA	W	CFP	20	25	506.98	26.16	6220	NA
JM38510/65601BSA	W	CFP	20	25	506.98	26.16	6220	NA
M38510/65601BSA	W	CFP	20	25	506.98	26.16	6220	NA
SN74HC273N	N	PDIP	20	20	506	13.97	11230	4.32
SN74HC273NE4	N	PDIP	20	20	506	13.97	11230	4.32
SNJ54HC273FK	FK	LCCC	20	55	506.98	12.06	2030	NA
SNJ54HC273W	W	CFP	20	25	506.98	26.16	6220	NA

DB0020A



PACKAGE OUTLINE

SSOP - 2 mm max height

SMALL OUTLINE PACKAGE



4214851/B 08/2019

NOTES:

1. All linear dimensions are in millimeters. Any dimensions in parenthesis are for reference only. Dimensioning and tolerancing per ASME Y14.5M.
2. This drawing is subject to change without notice.
3. This dimension does not include mold flash, protrusions, or gate burrs. Mold flash, protrusions, or gate burrs shall not exceed 0.15 mm per side.
4. This dimension does not include interlead flash. Interlead flash shall not exceed 0.25 mm per side.
5. Reference JEDEC registration MO-150.

EXAMPLE BOARD LAYOUT

DB0020A

SSOP - 2 mm max height

SMALL OUTLINE PACKAGE



LAND PATTERN EXAMPLE
EXPOSED METAL SHOWN
SCALE: 10X



4214851/B 08/2019

NOTES: (continued)

- 6. Publication IPC-7351 may have alternate designs.
- 7. Solder mask tolerances between and around signal pads can vary based on board fabrication site.

EXAMPLE STENCIL DESIGN

DB0020A

SSOP - 2 mm max height

SMALL OUTLINE PACKAGE

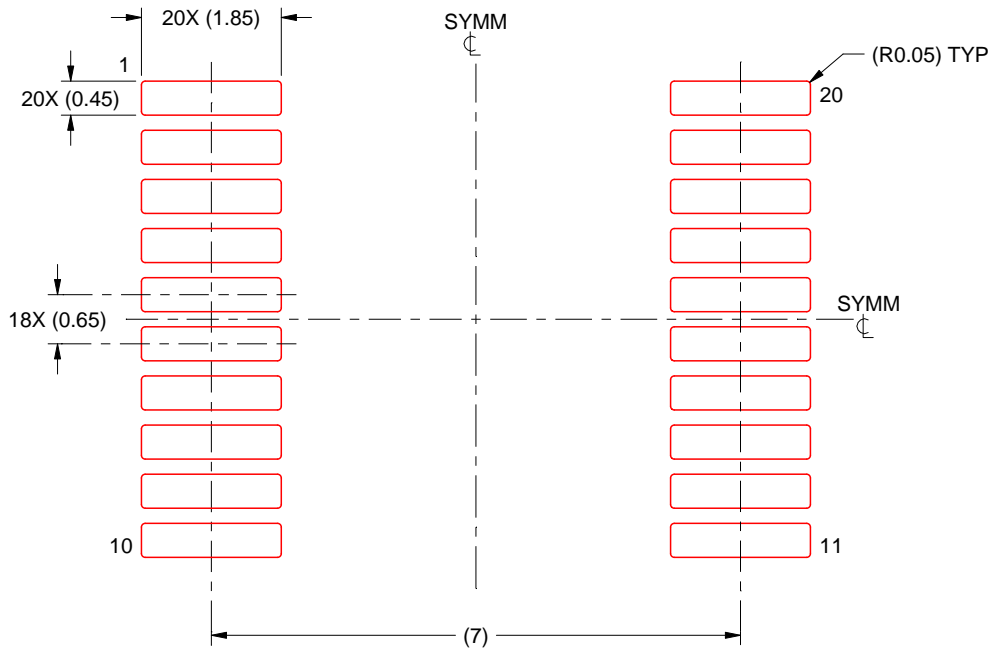

SOLDER PASTE EXAMPLE
BASED ON 0.125 mm THICK STENCIL
SCALE: 10X

4214851/B 08/2019

NOTES: (continued)

8. Laser cutting apertures with trapezoidal walls and rounded corners may offer better paste release. IPC-7525 may have alternate design recommendations.
9. Board assembly site may have different recommendations for stencil design.

MECHANICAL DATA

NS (R-PDSO-G**)

PLASTIC SMALL-OUTLINE PACKAGE

14-PINS SHOWN



- NOTES:
- A. All linear dimensions are in millimeters.
 - B. This drawing is subject to change without notice.
 - C. Body dimensions do not include mold flash or protrusion, not to exceed 0,15.

J (R-GDIP-T**)

14 LEADS SHOWN

CERAMIC DUAL IN-LINE PACKAGE



DIM \ PINS **	14	16	18	20
A	0.300 (7,62) BSC	0.300 (7,62) BSC	0.300 (7,62) BSC	0.300 (7,62) BSC
B MAX	0.785 (19,94)	.840 (21,34)	0.960 (24,38)	1.060 (26,92)
B MIN	—	—	—	—
C MAX	0.300 (7,62)	0.300 (7,62)	0.310 (7,87)	0.300 (7,62)
C MIN	0.245 (6,22)	0.245 (6,22)	0.220 (5,59)	0.245 (6,22)



4040083/F 03/03

- NOTES:
- All linear dimensions are in inches (millimeters).
 - This drawing is subject to change without notice.
 - This package is hermetically sealed with a ceramic lid using glass frit.
 - Index point is provided on cap for terminal identification only on press ceramic glass frit seal only.
 - Falls within MIL STD 1835 GDIP1-T14, GDIP1-T16, GDIP1-T18 and GDIP1-T20.

GENERIC PACKAGE VIEW

FK 20

LCCC - 2.03 mm max height

8.89 x 8.89, 1.27 mm pitch

LEADLESS CERAMIC CHIP CARRIER

This image is a representation of the package family, actual package may vary.
Refer to the product data sheet for package details.



4229370VA\

N (R-PDIP-T**)

PLASTIC DUAL-IN-LINE PACKAGE

16 PINS SHOWN



4040049/E 12/2002

- NOTES:
- A. All linear dimensions are in inches (millimeters).
 - B. This drawing is subject to change without notice.
 - C Falls within JEDEC MS-001, except 18 and 20 pin minimum body length (Dim A).
 - D The 20 pin end lead shoulder width is a vendor option, either half or full width.

DW0020A



PACKAGE OUTLINE

SOIC - 2.65 mm max height

SOIC



4220724/A 05/2016

NOTES:

1. All linear dimensions are in millimeters. Dimensions in parenthesis are for reference only. Dimensioning and tolerancing per ASME Y14.5M.
2. This drawing is subject to change without notice.
3. This dimension does not include mold flash, protrusions, or gate burrs. Mold flash, protrusions, or gate burrs shall not exceed 0.15 mm per side.
4. This dimension does not include interlead flash. Interlead flash shall not exceed 0.43 mm per side.
5. Reference JEDEC registration MS-013.

EXAMPLE BOARD LAYOUT

DW0020A

SOIC - 2.65 mm max height

SOIC



LAND PATTERN EXAMPLE
SCALE:6X



SOLDER MASK DETAILS

4220724/A 05/2016

NOTES: (continued)

- 6. Publication IPC-7351 may have alternate designs.
- 7. Solder mask tolerances between and around signal pads can vary based on board fabrication site.

EXAMPLE STENCIL DESIGN

DW0020A

SOIC - 2.65 mm max height

SOIC



SOLDER PASTE EXAMPLE
BASED ON 0.125 mm THICK STENCIL
SCALE:6X

4220724/A 05/2016

NOTES: (continued)

8. Laser cutting apertures with trapezoidal walls and rounded corners may offer better paste release. IPC-7525 may have alternate design recommendations.
9. Board assembly site may have different recommendations for stencil design.

W (R-GDFP-F20)

CERAMIC DUAL FLATPACK

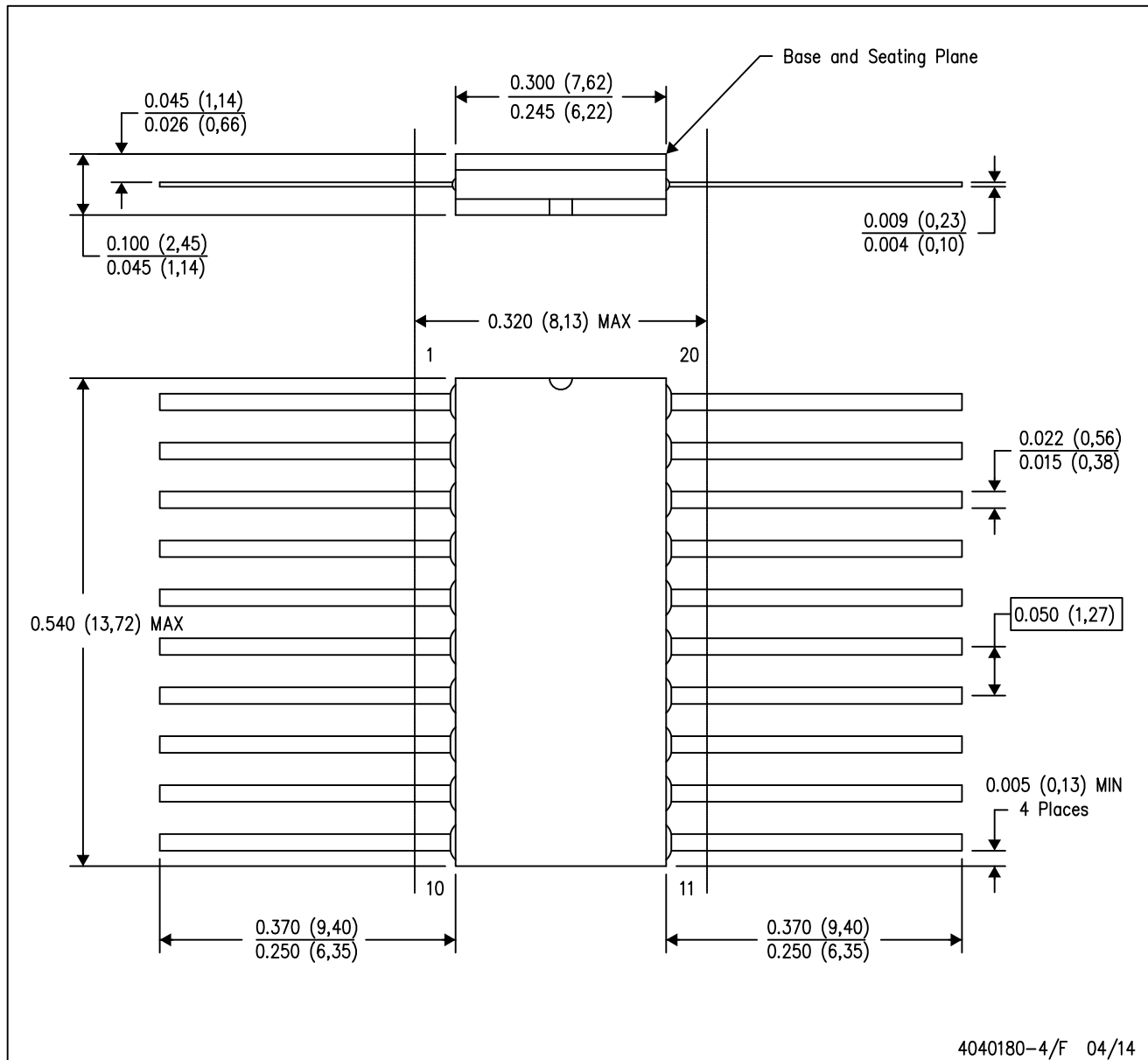

- NOTES:
- A. All linear dimensions are in inches (millimeters).
 - B. This drawing is subject to change without notice.
 - C. This package can be hermetically sealed with a ceramic lid using glass frit.
 - D. Index point is provided on cap for terminal identification only.
 - E. Falls within Mil-Std 1835 GDFP2-F20

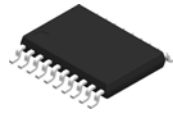

4220206/A 02/2017

NOTES:

1. All linear dimensions are in millimeters. Any dimensions in parenthesis are for reference only. Dimensioning and tolerancing per ASME Y14.5M.
2. This drawing is subject to change without notice.
3. This dimension does not include mold flash, protrusions, or gate burrs. Mold flash, protrusions, or gate burrs shall not exceed 0.15 mm per side.
4. This dimension does not include interlead flash. Interlead flash shall not exceed 0.25 mm per side.
5. Reference JEDEC registration MO-153.

EXAMPLE BOARD LAYOUT

PW0020A

TSSOP - 1.2 mm max height

SMALL OUTLINE PACKAGE



LAND PATTERN EXAMPLE
EXPOSED METAL SHOWN
SCALE: 10X



SOLDER MASK DETAILS

4220206/A 02/2017

NOTES: (continued)

- 6. Publication IPC-7351 may have alternate designs.
- 7. Solder mask tolerances between and around signal pads can vary based on board fabrication site.

EXAMPLE STENCIL DESIGN

PW0020A

TSSOP - 1.2 mm max height

SMALL OUTLINE PACKAGE



SOLDER PASTE EXAMPLE
BASED ON 0.125 mm THICK STENCIL
SCALE: 10X

4220206/A 02/2017

NOTES: (continued)

8. Laser cutting apertures with trapezoidal walls and rounded corners may offer better paste release. IPC-7525 may have alternate design recommendations.
9. Board assembly site may have different recommendations for stencil design.

PW (R-PDSO-G20)

PLASTIC SMALL OUTLINE

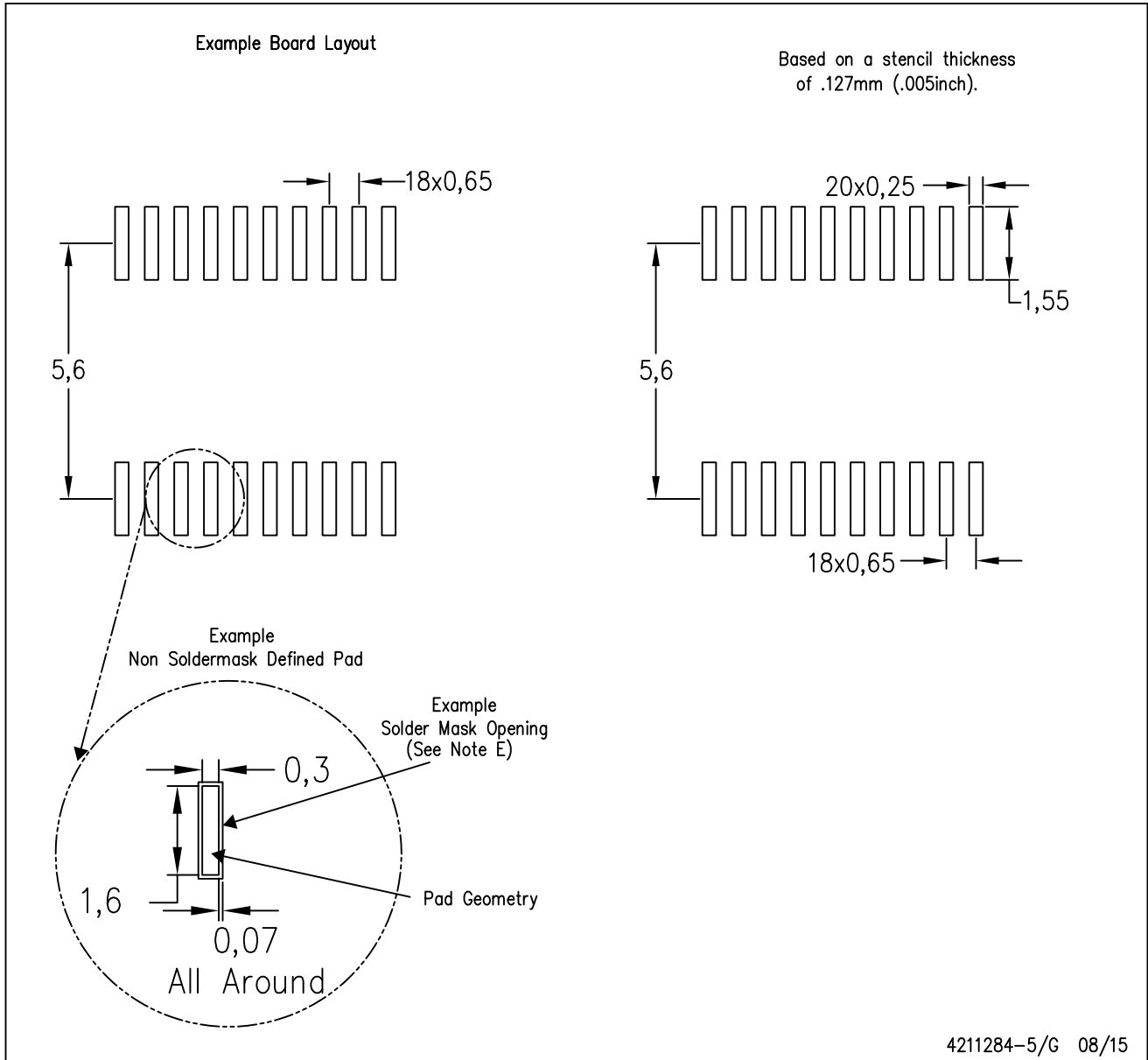

- NOTES:
- A. All linear dimensions are in millimeters.
 - B. This drawing is subject to change without notice.
 - C. Publication IPC-7351 is recommended for alternate design.
 - D. Laser cutting apertures with trapezoidal walls and also rounding corners will offer better paste release. Customers should contact their board assembly site for stencil design recommendations. Refer to IPC-7525 for other stencil recommendations.
 - E. Customers should contact their board fabrication site for solder mask tolerances between and around signal pads.

IMPORTANT NOTICE AND DISCLAIMER

TI PROVIDES TECHNICAL AND RELIABILITY DATA (INCLUDING DATA SHEETS), DESIGN RESOURCES (INCLUDING REFERENCE DESIGNS), APPLICATION OR OTHER DESIGN ADVICE, WEB TOOLS, SAFETY INFORMATION, AND OTHER RESOURCES "AS IS" AND WITH ALL FAULTS, AND DISCLAIMS ALL WARRANTIES, EXPRESS AND IMPLIED, INCLUDING WITHOUT LIMITATION ANY IMPLIED WARRANTIES OF MERCHANTABILITY, FITNESS FOR A PARTICULAR PURPOSE OR NON-INFRINGEMENT OF THIRD PARTY INTELLECTUAL PROPERTY RIGHTS.

These resources are intended for skilled developers designing with TI products. You are solely responsible for (1) selecting the appropriate TI products for your application, (2) designing, validating and testing your application, and (3) ensuring your application meets applicable standards, and any other safety, security, regulatory or other requirements.

These resources are subject to change without notice. TI grants you permission to use these resources only for development of an application that uses the TI products described in the resource. Other reproduction and display of these resources is prohibited. No license is granted to any other TI intellectual property right or to any third party intellectual property right. TI disclaims responsibility for, and you will fully indemnify TI and its representatives against, any claims, damages, costs, losses, and liabilities arising out of your use of these resources.

TI's products are provided subject to [TI's Terms of Sale](#) or other applicable terms available either on [ti.com](https://www.ti.com) or provided in conjunction with such TI products. TI's provision of these resources does not expand or otherwise alter TI's applicable warranties or warranty disclaimers for TI products.

TI objects to and rejects any additional or different terms you may have proposed.

Mailing Address: Texas Instruments, Post Office Box 655303, Dallas, Texas 75265
Copyright © 2024, Texas Instruments Incorporated

Looking for pricing, stock, or lifecycle information?

Click below to explore more details on WIN SOURCE:

 [View SN74HC273NE4 on WIN SOURCE](#)

 [Texas Instruments](#) Information

Optimize Your Supply Chain with WIN SOURCE Solutions

-  Global Sourcing Solution
-  Obsolete Management
-  Cost Control Management
-  Shortage Management
-  Alternative Solution
-  Excess Inventory Management