



**THE DATASHEET OF
MAX1603EAI**





Dual-Channel CardBus and PCMCIA VCC/VPP Power-Switching Networks

MAX1600/MAX1603

General Description

The MAX1600/MAX1603 DC power-switching ICs contain a network of low-resistance MOSFET switches that deliver selectable VCC and VPP voltages to two CardBus or PC Card host sockets. Key features include ultra-low-resistance switches, small packaging, soft-switching action, and compliance with PCMCIA specifications for 3V/5V switching. 3.3V-only power switching for fast, 32-bit CardBus applications is supported in two ways: stiff, low-resistance 3.3V switches allow high 3.3V load currents (up to 1A); and completely independent internal charge pumps let the 3.3V switch operate normally, even if the +5V and +12V supplies are disconnected or turned off to conserve power. The internal charge pumps are regulating types that draw reduced input current when the VCC switches are static. Also, power consumption is automatically reduced to 10µA max when the control logic inputs are programmed to high-Z or GND states, unlike other solutions that may require a separate shutdown-control input.

Other key features include guaranteed specifications for output current limit level, and guaranteed specifications for output rise/fall times (in compliance with PCMCIA specifications). Reliability is enhanced by thermal-overload protection, accurate current limiting, an overcurrent-fault flag output, and undervoltage lock-out. The CMOS/TTL-logic interface is flexible, and can tolerate logic input levels in excess of the positive supply rail.

The MAX1600 and MAX1603 are identical, except for the MAX1603's VY switch on-resistance (typically 140mΩ). The MAX1600/MAX1603 fit two complete CardBus/ PCMCIA switches into a space-saving, narrow (0.2in. or 5mm wide) SSOP package.

Applications

- | | |
|--------------------|--------------------------|
| Desktop Computers | Data Loggers |
| Notebook Computers | Docking Stations |
| Handy-Terminals | PCMCIA Read/Write Drives |

Ordering Information

PART	TEMP. RANGE	PIN-PACKAGE
MAX1600EAI	-40°C to +85°C	28 SSOP
MAX1603EAI	-40°C to +85°C	28 SSOP

Pin Configuration appears on last page.

Features

- ◆ Supports Two PC Card/CardBus Sockets
- ◆ 1A, 0.08Ω Max 3.3V VCC Switch (MAX1600 only)
- ◆ 1A, 0.14Ω Max 5V VCC Switch
- ◆ Soft Switching for Low Inrush Surge Current
- ◆ Overcurrent Protection
- ◆ Overcurrent/Thermal-Fault Flag Output
- ◆ Thermal Shutdown at T_j = +150°C
- ◆ Independent Internal Charge Pumps
- ◆ Break-Before-Make Switching Action
- ◆ 10µA Max Standby Supply Current
- ◆ 5V and 12V Not Required for Low-R_{DS(ON)} 3.3V Switching
- ◆ Complies with PCMCIA 3V/5V Switching Specifications
- ◆ Super-Small 28-Pin SSOP Package (0.2in. or 5mm wide)
- ◆ Code Compatible with:
 - ◆ Cirrus CL-PD67XX Family Databook DB86184
 - ◆ Intel 82365SL (industry-standard coding)

Simplified Block Diagram

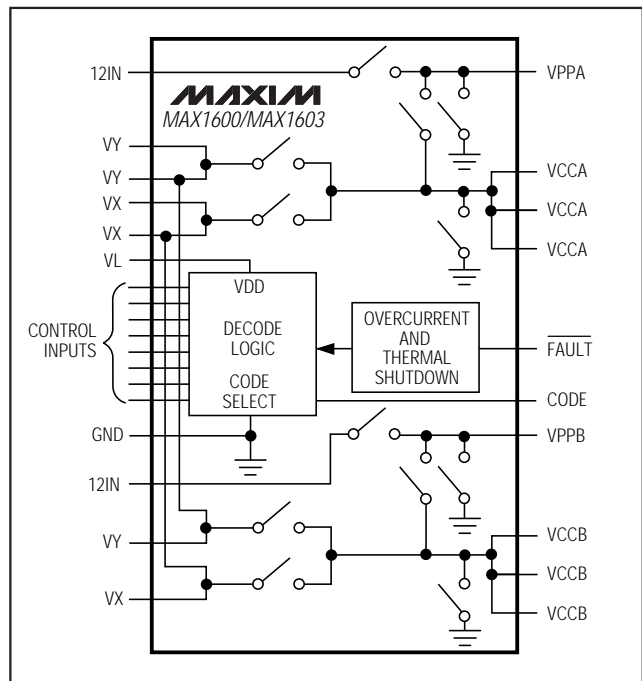

Dual-Channel CardBus and PCMCIA VCC/VPP Power-Switching Networks

ABSOLUTE MAXIMUM RATINGS

Inputs/Outputs to GND (VL, VX, VY, VCCA, VCCB) (Note 1)	-0.3V, +6V
VPP Inputs/Outputs to GND (12INA, 12INB, VPPA, VPPB) (Note 1)	-0.3V, +15V
Logic Inputs to GND (A0VCC, A1VCC, B0VCC, B1VCC, A0VPP, A1VPP, B0VPP, B1VPP) (Note 1)	-0.3V, +6V
CODE Input to GND	-0.3V, (VL + 0.3V)
VCCA, VCCB Output Current (Note 2)	4A
VPPA, VPPB Output Current (Note 2)	250mA

VCCA, VCCB Short Circuit to GND	Continuous
VPPA, VPPB Short Circuit to GND	Continuous
Continuous Power Dissipation (TA = +70°C) SSOP (derate 9.52mW/°C above +70°C)	762mW
Operating Temperature Range MAX160_EAI/MAX1603EAI	-40°C to +85°C
Storage Temperature Range	-65°C to +160°C
Lead Temperature (soldering, 10sec)	+300°C

Note 1: There are no parasitic diodes between any of these pins, so there are no power-up sequencing restrictions (for example, logic input signals can be applied even if all of the supply voltage inputs are grounded).

Note 2: VCC and VPP outputs are internally current limited. See the *Electrical Characteristics*.

Stresses beyond those listed under "Absolute Maximum Ratings" may cause permanent damage to the device. These are stress ratings only, and functional operation of the device at these or any other conditions beyond those indicated in the operational sections of the specifications is not implied. Exposure to absolute maximum rating conditions for extended periods may affect device reliability.

ELECTRICAL CHARACTERISTICS

(VL = VY = 3.3V, VX = 5V, 12INA = 12INB = 12V, TA = 0°C to +85°C, unless otherwise noted. Typical values are at TA = +25°C.)

PARAMETER	CONDITIONS	MIN	TYP	MAX	UNITS
POWER-SUPPLY SECTION					
Input Voltage Range	VX, VY or VL	3.0		5.5	V
	12INA, 12INB	11		13	
Undervoltage Lockout Threshold	VL falling edge	2.4	2.5	2.8	V
	12IN falling edge	1.8	3.0		
	12IN rising edge	5.0	8.0	10.0	
	VX, VY falling edge	1.4	2.5	2.8	
Standby Supply Current	VX or VY, all switches 0V or high-Z, control inputs = 0V or VL, TA = +25°C			1	μA
VY Quiescent Supply Current	Any combination of VY switches on, control inputs = 0V or VL, no VCC loads		20	100	μA
VX Quiescent Supply Current	Any combination of VX switches on, control inputs = 0V or high-Z, no VCC loads		20	100	μA
12IN_ Standby Supply Current	12INA tied to 12INB, all switches 0V or high-Z, control inputs = 0V or VL, TA = +25°C			1	μA
12IN_ Quiescent Supply Current	12INA tied to 12INB, VPPA and VPPB 12V switches on, control inputs = 0V or VL, no VPP loads		15	100	μA
VL Standby Supply Current	All switches 0V or high-Z, control inputs = 0V or VL, TA = +25°C		4	10	μA
VL Quiescent Supply Current	Any combination of switches on		25	150	μA
VL Fall Rate	When using VL as shutdown pin (Note 3)			0.05	V/μs
VCC SWITCHES					
Operating Output Current Range	VCCA or VCCB, VX = VY = 3V to 5.5V	0		1	A
On-Resistance, VY Switches	12INA = 12INB = 0V to 13V, VY = 3V, VX = 0V to 5.5V, ISWITCH = 1A, TA = +25°C	MAX1600	0.06	0.08	Ω
		MAX1603	0.14	0.24	
On-Resistance, VX Switches	12INA = 12INB = 0V to 13V, VX = 4.5V, VY = 0V to 5.5V, ISWITCH = 1A, TA = +25°C		0.10	0.14	Ω
Output Current Limit	VCCA or VCCB	1.2		4	A

Dual-Channel CardBus and PCMCIA VCC/VPP Power-Switching Networks

MAX1600/MAX1603

ELECTRICAL CHARACTERISTICS (continued)

(VL = VY = 3.3V, VX = 5V, 12INA = 12INB = 12V, TA = 0°C to +85°C, unless otherwise noted. Typical values are at TA = +25°C.)

PARAMETER	CONDITIONS	MIN	TYP	MAX	UNITS
Output Sink Current	VCCA or VCCB < 0.4V, programmed to 0V state	20			mA
Output Leakage Current	VCCA or VCCB forced to 0V, high-Z state, TA = +25°C			10	μA
Output Propagation Delay Plus Rise Time	VCCA or VCCB, 0V to VX or VY, CL = 30μF, RL = 25Ω, 50% of input to 90% of output, TA = +25°C		2	10	ms
Output Rise Time	VCCA or VCCB, 0V to VX or VY, CL = 1μF, RL = open circuit, 10% to 90% points, TA = +25°C	100	1200		μs
Output Propagation Delay Plus Fall Time	VCCA or VCCB, VX or VY to 0V, CL = 30μF, RL = open circuit, 50% of input to 10% of output, TA = +25°C		60	100	ms
Output Fall Time	VCCA or VCCB, VX or VY to 0V, CL = 1μF, RL = 25Ω, 90% to 10% points		6		ms
VPP SWITCHES					
Operating Output Current Range	VPPA or VPPB	0		120	mA
On-Resistance, 12V Switches	12IN = 11.6V, ISWITCH = 100mA, TA = +25°C		0.70	1	Ω
On-Resistance, VPP = VCC Switches	Programmed to VX (5V) or VY (3.3V), TA = +25°C		1	3	Ω
Output Current Limit	VPPA or VPPB, programmed to 12V	130	200	260	mA
Output Sink Current	VPPA or VPPB < 0.4V, programmed to 0V state	10			mA
Output Leakage Current	VPPA or VPPB forced to 0V, high-Z state, TA = +25°C			10	μA
Output Propagation Delay Plus Rise Time	VPPA or VPPB, 0V to 12IN_, CL = 0.1μF, 50% of input to 90% of output, TA = +25°C		1.2	30	ms
Output Rise Time	VPPA or VPPB, 0V to 12IN_, CL = 0.1μF, 10% to 90% points, TA = +25°C	100	800		μs
Output Propagation Delay Plus Fall Time	VPPA or VPPB, 12IN_ to 0V, CL = 0.1μF, 50% of input to 10% of output, TA = +25°C		9	60	ms
Output Fall Time	VPPA or VPPB, 12IN_ to 0V, CL = 0.1μF, 90% to 10% points		1		ms
INTERFACE AND LOGIC SECTION					
FAULT Signal Propagation Delay	VCC_ or VPP_, load step to FAULT output, 50% point to 50% point (Note 3)		1		μs
FAULT Output Low Voltage	ISINK = 1mA, low state			0.4	V
FAULT Output Leakage Current	VFAULT = 5.5V, high state	-0.5		0.5	μA
Thermal Shutdown Threshold	Hysteresis = 20°C (Note 4)		150		°C
Logic Input Low Voltage	__VCC, __VPP			0.6	V
Logic Input High Voltage	__VCC, __VPP	1.5			V
Code Input Low Voltage	"Intel" code	0		0.4	V
Code Input High Voltage	"Cirrus" code	VL - 0.4		VL	V
Code Input Mid-Level Voltage	"Databook" code	1.2		VL - 1.2	V
Logic Input Bias Current	__VCC, __VPP, code	-1		1	μA

Dual-Channel CardBus and PCMCIA VCC/VPP Power-Switching Networks

ELECTRICAL CHARACTERISTICS

(VL = VY = 3.3V, VX = 5V, 12INA = 12INB = 12V, TA = -40°C to +85°C, unless otherwise noted.)

PARAMETER	CONDITIONS	MIN	TYP	MAX	UNITS
POWER-SUPPLY SECTION					
Input Voltage Range	VX, VY or VL	3.0		5.5	V
	12INA, 12INB	11		13	
Undervoltage Lockout Threshold	VL falling edge, hysteresis = 1%	2.3		2.9	V
	12IN falling edge	1.8			
	12IN rising edge	5		10	
	VX, VY falling edge	1.4		2.9	
Standby Supply Current	VX or VY, all switches 0V or high-Z, control inputs = 0V or VL, TA = TMIN to TMAX			15	μA
VY Quiescent Supply Current	Any combination of VY switches on, control inputs = 0V or VL, no VCC loads			100	μA
VX Quiescent Supply Current	Any combination of VX switches on, control inputs = 0V or high-Z, no VCC loads			100	μA
12IN_ Standby Supply Current	12INA tied to 12INB, all switches 0V or high-Z, control inputs = 0V or VL			15	μA
12IN_ Quiescent Supply Current	12INA tied to 12INB, VPPA and VPPB 12V switches on, control inputs = 0V or VL, no VPP loads			100	μA
VL Standby Supply Current	All switches 0V or high-Z, control inputs = 0V or VL			15	μA
VL Quiescent Supply Current	Any combination of switches on			150	μA
FAULT Output Low Voltage	ISINK = 1mA, low state			0.4	V
Logic Input Low Voltage	__VCC, __VPP			0.6	V
Logic Input High Voltage	__VCC, __VPP	1.6			V

Note 3: Not production tested.

Note 4: Thermal limit not active in standby state (all switches programmed to GND or high-Z state).

Typical Operating Characteristics

(VL = VY = 3.3V, VX = 5V = 12IN, TA = +25°C, unless otherwise noted.)

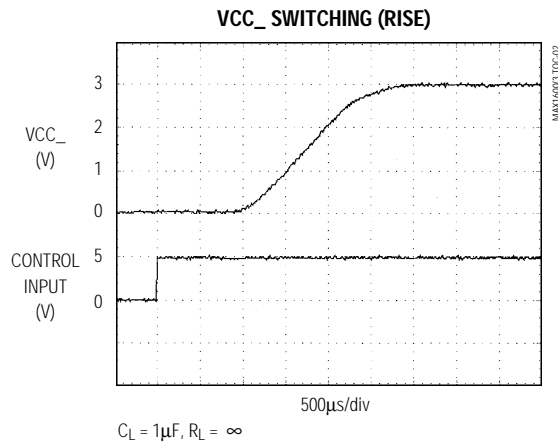
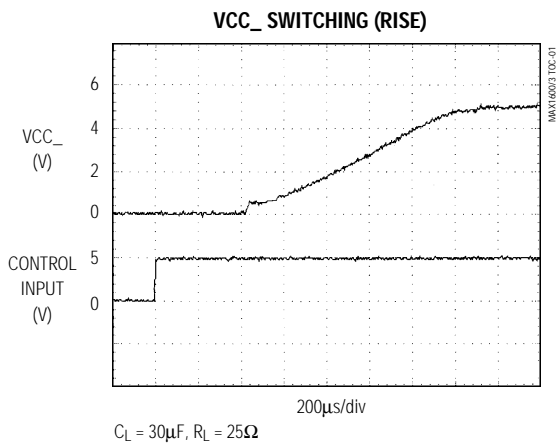

Dual-Channel CardBus and PCMCIA VCC/VPP Power-Switching Networks

MAX1600/MAX1603

Typical Operating Characteristics (continued)
 (VL = VY = 3.3V, VX = 5V = 12IN, TA = +25°C, unless otherwise noted.)

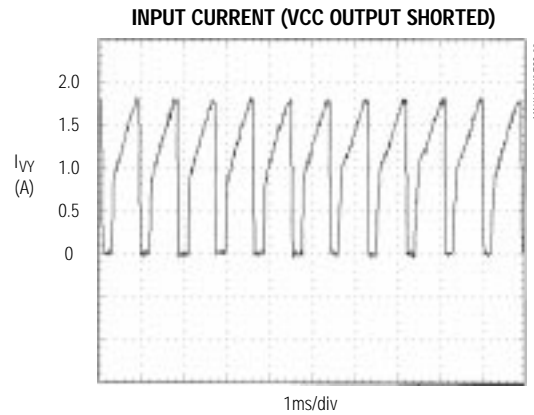
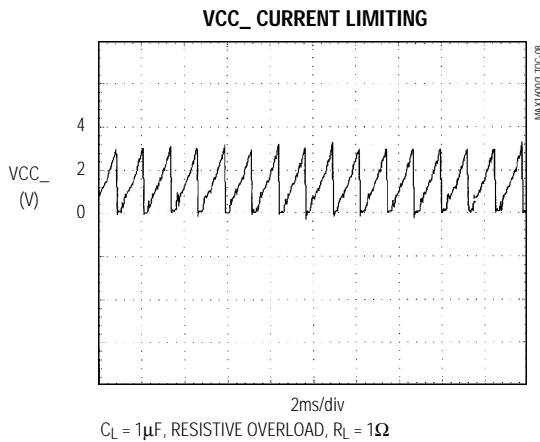
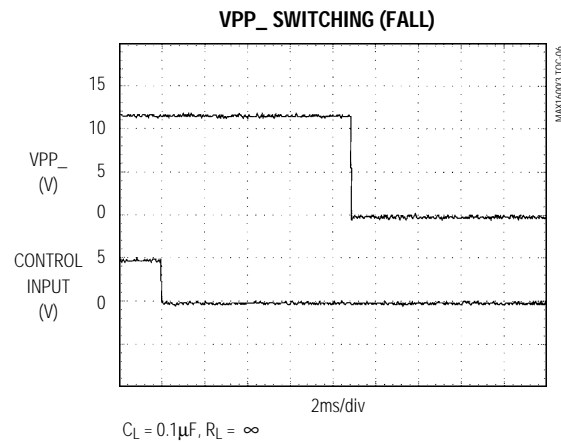
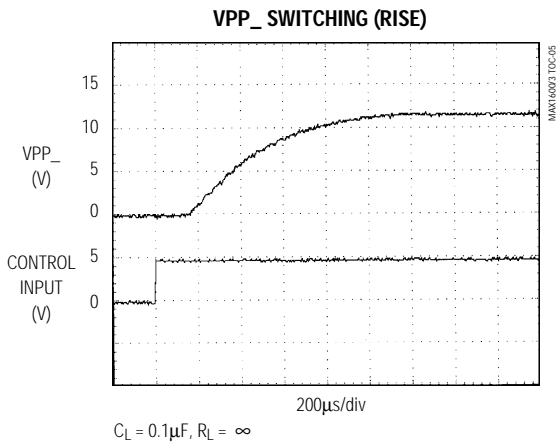
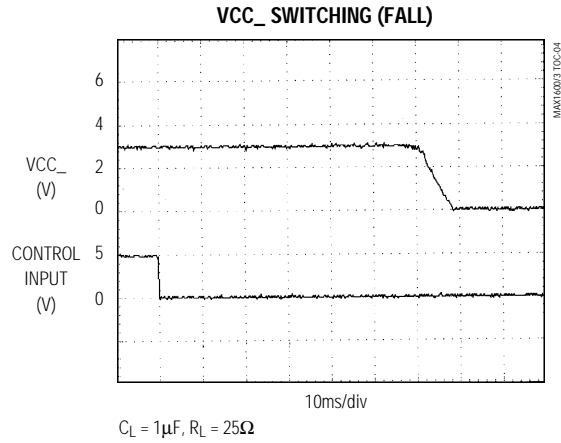
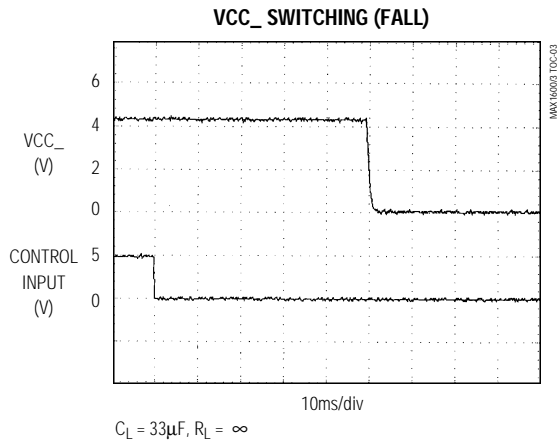

Dual-Channel CardBus and PCMCIA VCC/VPP Power-Switching Networks

Typical Operating Characteristics (continued)

(VL = VY = 3.3V, VX = 5V = 12IN, TA = +25°C, unless otherwise noted.)

VPP_ CURRENT LIMITING

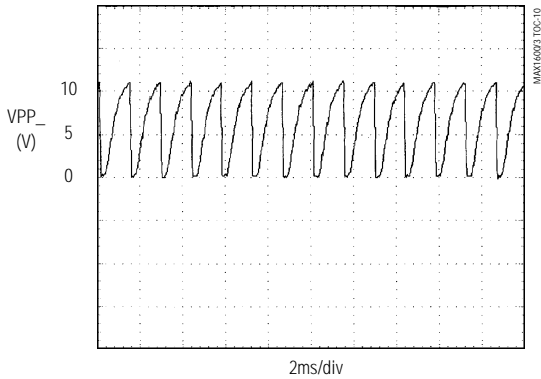

CL = 1μF, RL = 50Ω

INPUT CURRENT (VPP OUTPUT SHORTED)

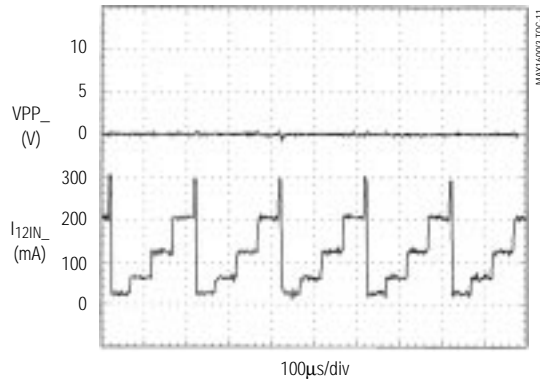

RL = 0.1Ω

VCC_ SHUTDOWN RESPONSE

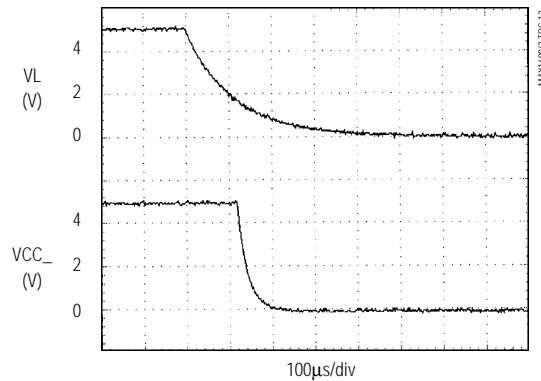

CIRCUIT OF FIGURE 2

12IN SUPPLY CURRENT vs. INPUT VOLTAGE

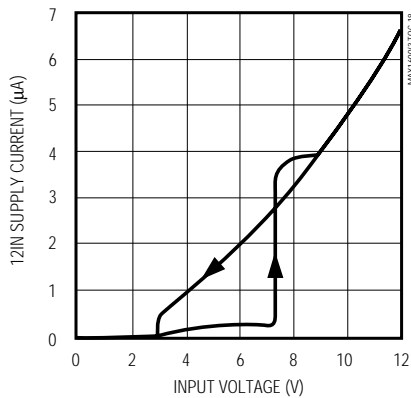

VL SUPPLY CURRENT vs. VL INPUT VOLTAGE

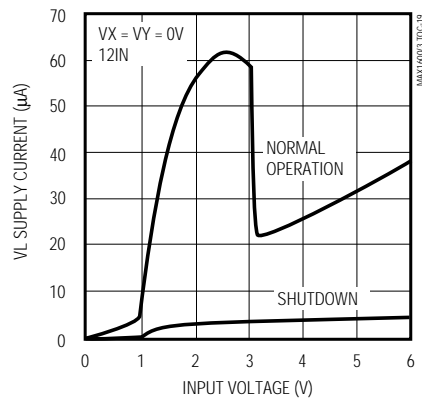

Dual-Channel CardBus and PCMCIA VCC/VPP Power-Switching Networks

MAX1600/MAX1603

Typical Operating Characteristics (continued)

(VL = VY = 3.3V, VX = 5V = 12IN, TA = +25°C, unless otherwise noted.)

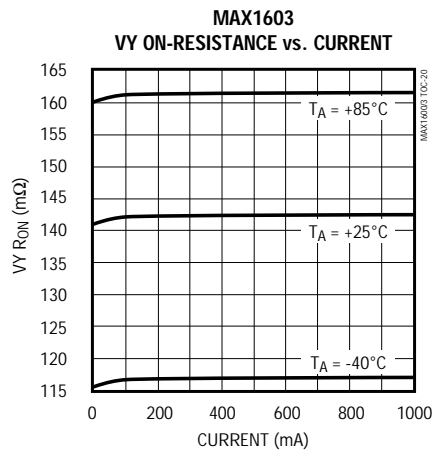
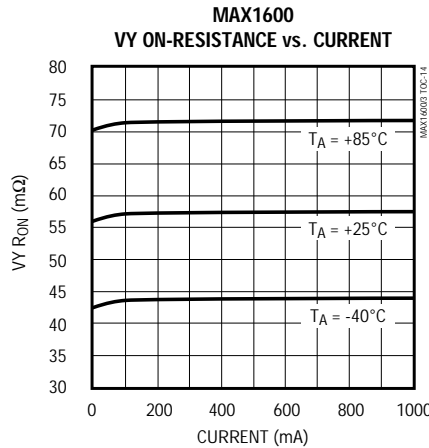
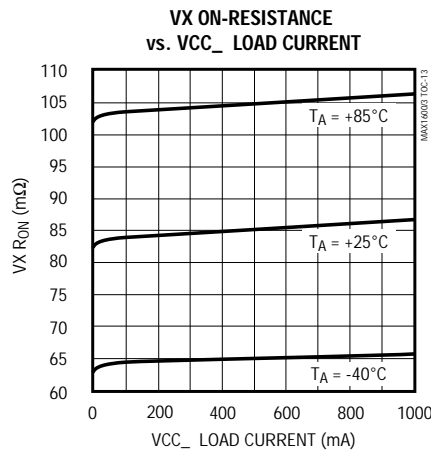
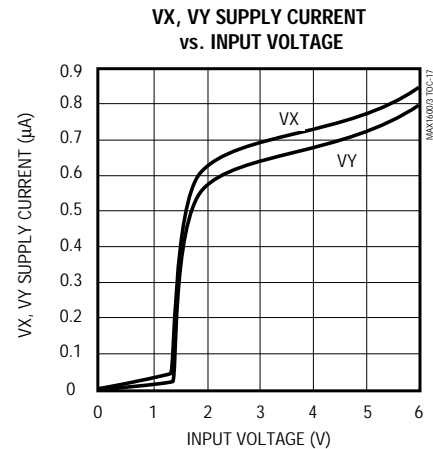
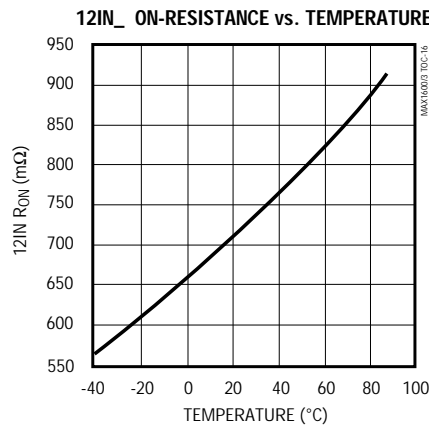
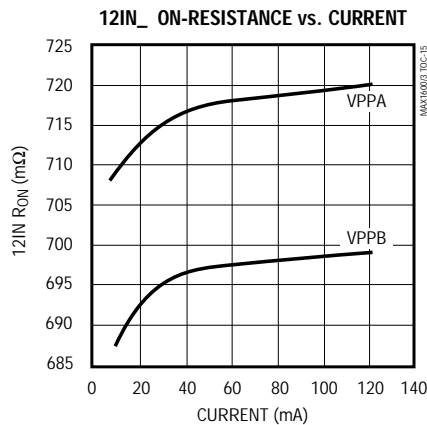

Pin Description

PIN	NAME	FUNCTION
1	GND	Ground
2	A1VPP	Channel A VPP Control Input. See <i>Logic Truth Tables</i> .
3	A0VPP	Channel A VPP Control Input. See <i>Logic Truth Tables</i> .
4	12INA	+12V Supply Voltage Input, internally connects to channel A VPP switch. Tie to VPPA if not used.
5	VPPA	Channel A VPP Output
6, 8, 10	VX	VX Supply Voltage Inputs. VX pins must be connected to one another. Input range is +3V to +5.5V. VX is normally connected to 5V.
7, 22, 24	VCCA	Channel A VCC Outputs
9, 18, 20	VCCB	Channel B VCC Outputs
11	VPPB	Channel B VPP Output
12	12INB	+12V Supply Voltage Input, internally connects to channel B VPP switch. Tie to VPPB if not used.

Dual-Channel CardBus and PCMCIA VCC/VPP Power-Switching Networks

Pin Description (continued)

PIN	NAME	FUNCTION
13	B0VPP	Channel B VPP Control Input. See <i>Logic Truth Tables</i> .
14	B1VPP	Channel B VPP Control Input. See <i>Logic Truth Tables</i> .
15	B0VCC	Channel B VCC Control Input. See <i>Logic Truth Tables</i> .
16	B1VCC	Channel B VCC Control Input. See <i>Logic Truth Tables</i> .
17	$\overline{\text{FAULT}}$	Fault-Detection Output. $\overline{\text{FAULT}}$ goes low during current limit, undervoltage lockout, or thermal limit. $\overline{\text{FAULT}}$ is an open-drain output that requires an external pull-up resistor.
19, 21, 23	VY	VY Supply Voltage Inputs. VY pins must be connected to one another. Input range is +3V to +5.5V. VY is normally connected to 3.3V.
25	CODE	Three-Level Code-Select Input. See <i>Logic Truth Tables</i> . Low = Standard "Intel" code High = "Cirrus" code Mid-supply = "Databook" code (Figure 6)
26	A1VCC	Channel A VCC Control Input. See <i>Logic Truth Tables</i> .
27	A0VCC	Channel A VCC Control Input. See <i>Logic Truth Tables</i> .
28	VL	Logic Supply-Voltage Input. Connect to the +3.3V or +5V host system supply. VL can be supplied via the output of a CMOS-logic gate to produce an overriding shutdown. When used as a shutdown input, VL should have a 1k Ω series resistor with a 0.1 μ F capacitor to ground (Figure 2). Note that VL must be greater than undervoltage lockout for any switches to be turned on.

Logic Truth Tables

**Table 1. Standard "Intel" Code (82365SL),
CODE = GND**

_1VCC	_0VCC	_1VPP	_0VPP	VCC_	VPP_	MODE
0	0	0	0	GND	GND	STBY
0	0	0	1	GND	GND	STBY
0	0	1	0	GND	GND	STBY
0	0	1	1	GND	GND	STBY
0	1	0	0	VY	GND	ACTIVE
0	1	0	1	VY	VCC_	ACTIVE
0	1	1	0	VY	12IN	ACTIVE
0	1	1	1	VY	High-Z	ACTIVE
1	0	0	0	VX	GND	ACTIVE
1	0	0	1	VX	VCC_	ACTIVE
1	0	1	0	VX	12IN	ACTIVE
1	0	1	1	VX	High-Z	ACTIVE
1	1	0	0	VY	GND	ACTIVE
1	1	0	1	VY	VCC_	ACTIVE
1	1	1	0	VY	12IN	ACTIVE
1	1	1	1	VY	High-Z	ACTIVE

STBY = Standby Mode

**Table 2. "Cirrus" Code,
CODE = High (VL)**

_1VCC	_0VCC	_1VPP	_0VPP	VCC_	VPP_	MODE
0	0	0	0	High-Z	High-Z	STBY
0	0	0	1	High-Z	High-Z	STBY
0	0	1	0	High-Z	High-Z	STBY
0	0	1	1	High-Z	High-Z	STBY
0	1	0	0	VX	GND	ACTIVE
0	1	0	1	VX	VCC_	ACTIVE
0	1	1	0	VX	12IN	ACTIVE
0	1	1	1	VX	High-Z	ACTIVE
1	0	0	0	VY	GND	ACTIVE
1	0	0	1	VY	VCC_	ACTIVE
1	0	1	0	VY	12IN	ACTIVE
1	0	1	1	VY	High-Z	ACTIVE
1	1	0	0	GND	GND	STBY
1	1	0	1	GND	GND	STBY
1	1	1	0	GND	GND	STBY
1	1	1	1	GND	GND	STBY

STBY = Standby Mode

Dual-Channel CardBus and PCMCIA VCC/VPP Power-Switching Networks

MAX1600/MAX1603

Logic Truth Tables (cont.)

Table 3. "Databook" Code, CODE = Mid-Supply (VL/2)

$_1VCC$	$_0VCC$	$_1VPP$	$_0VPP$	VCC $_$	VPP $_$	MODE
0	0	0	X	GND	High-Z	STBY
0	0	1	X	VY	12IN	ACTIVE
0	1	0	X	GND	GND	STBY
0	1	1	X	VX	12IN	ACTIVE
1	0	0	X	VY	VCC $_$	ACTIVE
1	0	1	X	VY	GND	ACTIVE
1	1	0	X	VX	VCC $_$	ACTIVE
1	1	1	X	VX	GND	ACTIVE

STBY = Standby Mode X = Don't Care

Detailed Description

The MAX1600/MAX1603 power-switching ICs contain a network of low-resistance MOSFET switches that deliver selectable VCC and VPP voltages to two CardBus or PC Card host sockets. The MAX1600/MAX1603 differ only in the VY switch on-resistance. Figure 1 is the detailed block diagram.

The power-input pins (VY, VX, 12IN $_$) are completely independent. Low inrush current is guaranteed by controlled switch rise times. VCC's 100 μ s minimum output rise time is 100% tested with a 1 μ F capacitive load, and VPP's 1ms minimum rise time is guaranteed with a 0.1 μ F load. These respective capacitive loads are chosen as worst-case card-insertion parameters. The internal switching control allows VCC and VPP rise times to be

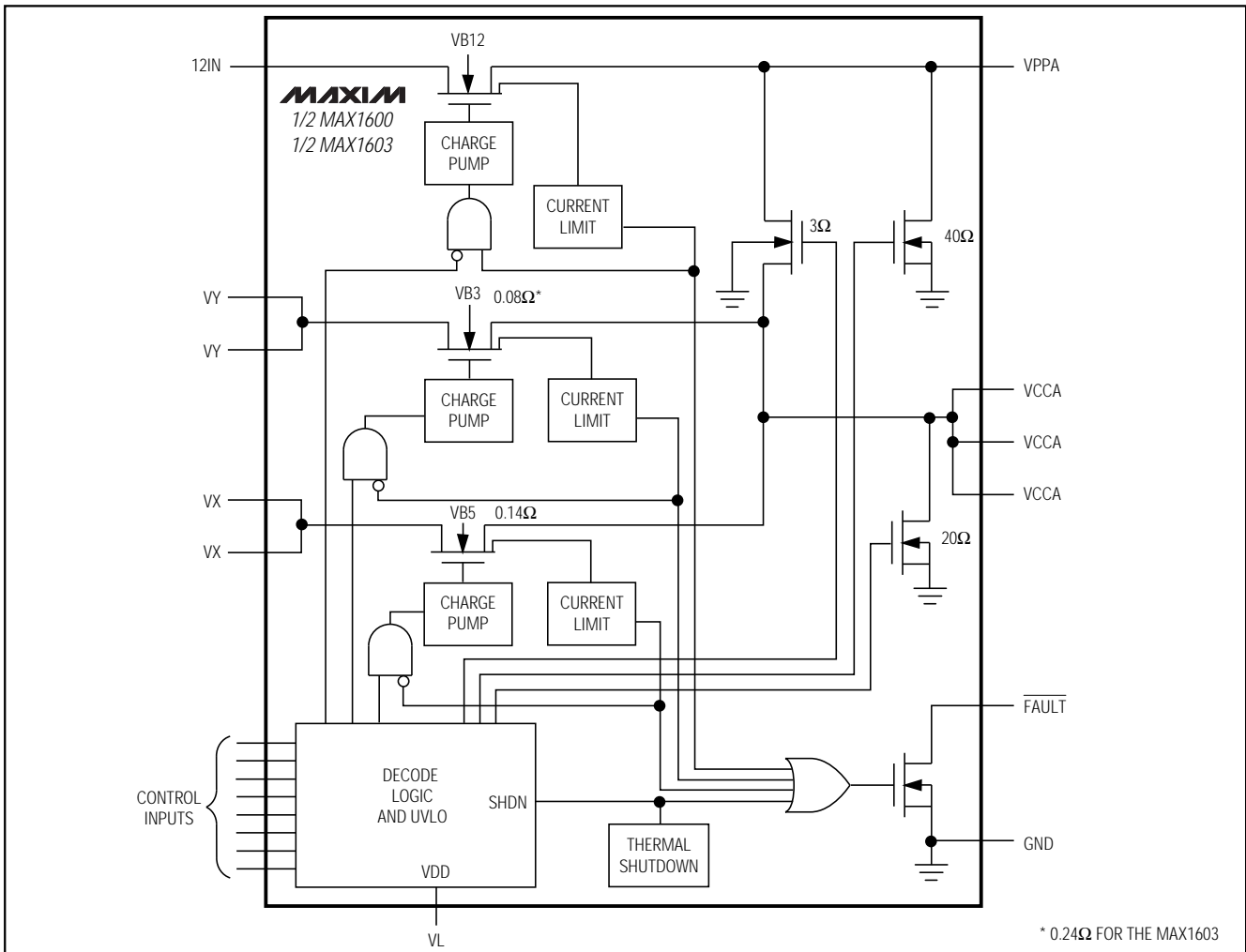

Figure 1. Detailed Block Diagram (one channel of two)

Dual-Channel CardBus and PCMCIA VCC/VPP Power-Switching Networks

controlled, and makes them nearly independent of resistive and capacitive loads (see rise-time photos in the *Typical Operating Characteristics*). Fall times are a function of loading, and are compensated by internal circuitry.

Power savings is automatic: internal charge pumps draw very low current when the VCC switches are static. Standby mode reduces switch supply current to 1 μ A. Driving the VL pin low with an external logic gate (master shutdown) reduces total supply current to 1 μ A (Figure 2).

Operating Modes

The MAX1600/MAX1603 are compatible with the Cirrus CL-PD67XX, Databook DB86184, and Intel 82365SL PC Card Interface Controllers (PCIC). Eight control inputs select the internal switches' positions and the operating modes according to the input code. Select the proper code format for the chosen controller with the CODE input pin (see *Pin Description* and Tables 1, 2, and 3). CODE reconfigures the logic decoder to one of three interface controllers:

Low = Standard "Intel" code (Figure 5)

High = "Cirrus" code (Figure 4)

Midsupply = "Databook" code (Figure 6)

An additional 1 μ A (3 μ A max) of VL supply current will flow if CODE = midsupply (VL / 2).

The MAX1600/MAX1603 have three operating modes: normal, standby, and shutdown. Normal mode supplies the selected outputs with their appropriate supply voltages. Standby mode places all switches at ground, high impedance, or a combination of the two. Shutdown mode turns all switches off, and puts the VCC and VPP outputs into a high-impedance state. Pull VL low to enter shutdown mode. To ensure a 0.05V/ μ s fall rate on VL, use a 1k Ω series resistor and a 0.1 μ F capacitor to ground (Figure 2).

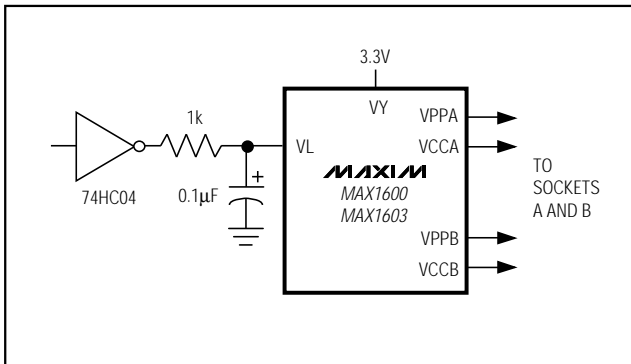

Figure 2. Master Shutdown Circuit

Overcurrent Protection

Peak detecting circuitry protects both the VCC and VPP switches against overcurrent conditions. When current through any switch exceeds the internal current limit (4A for VCC switches and 200mA for VPP switches) the switch turns off briefly, then turns on again at the controlled rise rate. If the overcurrent condition lasts more than 2 μ s, the FAULT output goes low. FAULT is not latched. A continuous short-circuit condition results in a pulsed output current and a pulsed FAULT output until thermal shutdown is reached. FAULT is open-drain and requires an external pull-up resistor.

Thermal Shutdown

If the IC junction temperature rises above +150°C, the thermal shutdown circuitry opens all switches, including the GND switches, and FAULT is pulled low. When the temperature falls below +130°C, the switches turn on again at the controlled rise rate. If the overcurrent condition remains, the part cycles between thermal shutdown and overcurrent.

Undervoltage Lockout

If the VX or VY switch input voltage drops below 1.5V, the associated switch turns off and FAULT goes low. For example, if VY is 3.3V and VX is 0V, and if the interface controller selects VY, the VCCA output will be 3.3V. If VX is selected, VCCA changes to a high-impedance output and FAULT goes low.

When a voltage is initially applied to 12IN₋, it must be greater than 8V to allow the switch to operate. Operation continues until the voltage falls below 2V (the VPP output is high impedance).

When VL drops to less than 2.3V, all switches are turned off and the VCC and VPP outputs are high impedance.

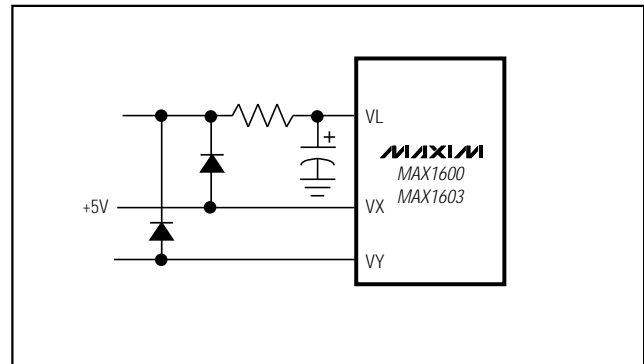

Figure 3. Applying Power to the VL Input

Dual-Channel CardBus and PCMCIA VCC/VPP Power-Switching Networks

MAX1600/MAX1603

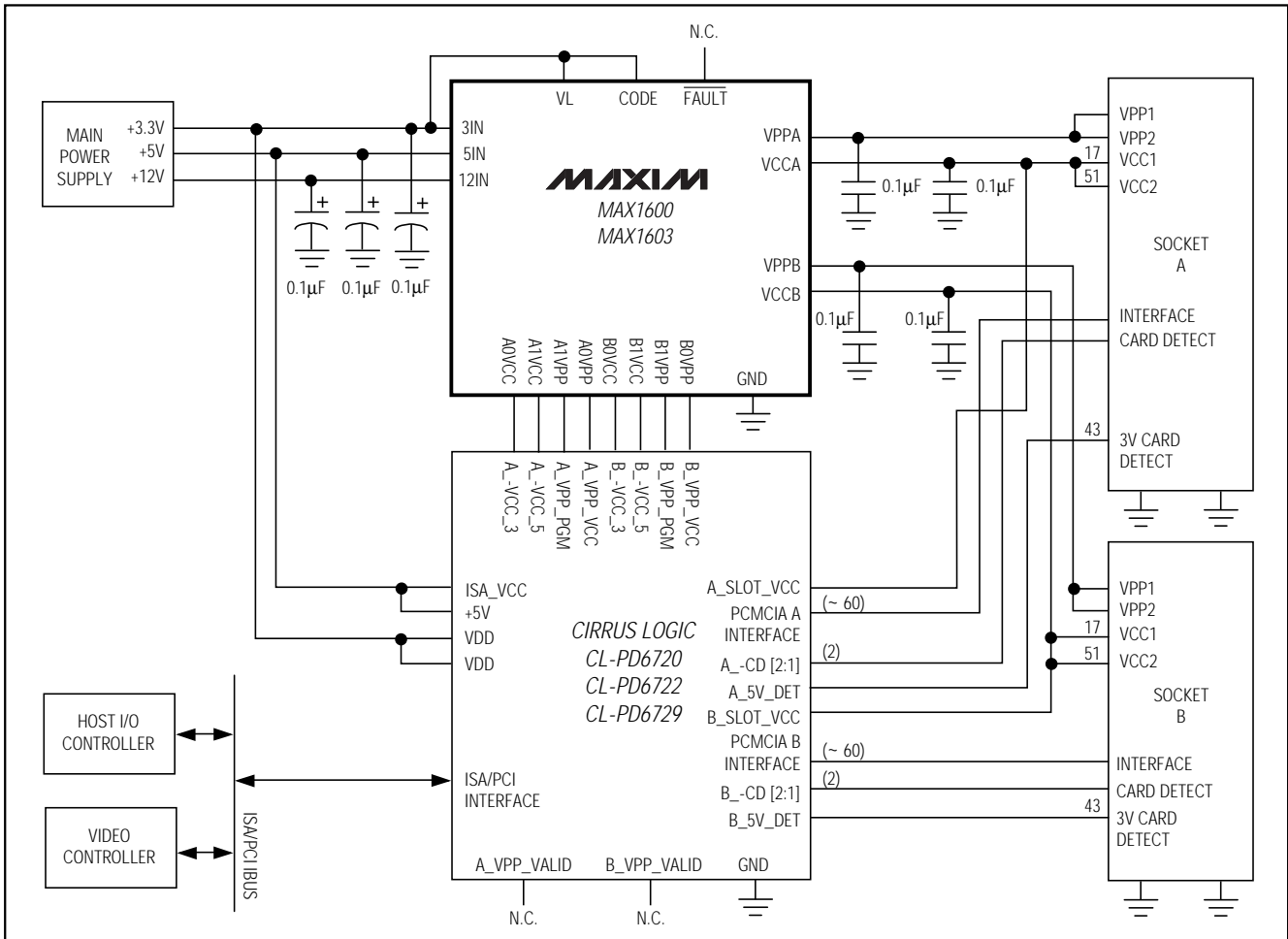

Figure 4. Application with Cirrus Logic Interface

Applications Information

Supply Bypassing

Bypass the VY, VX, and 12IN₊ inputs with ceramic 0.1µF capacitors. Bypass the VCC₊ and VPP₊ outputs with a 0.1µF capacitor for noise reduction and ESD protection.

Power-Up

Apply power to the VL input before any of the switch inputs. If VX, VY, or 12IN₊ receive power before VL rises above 2.8V, the supply current may be artificially high (about 5mA). When the voltage on VL is greater than 2.8V, the part consumes its specified 24µA. To avoid power sequencing, diode-OR VX and VY to VL through a 1kΩ resistor (Figure 3). Take care not to allow VL to drop below the 2.8V maximum undervoltage lockout threshold.

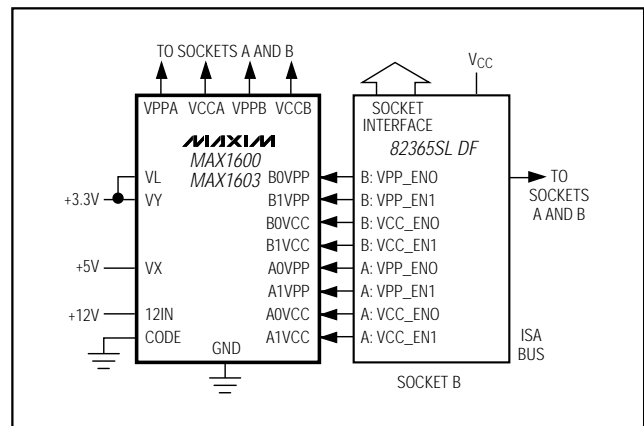

Figure 5. Application with Intel Interface

Dual-Channel CardBus and PCMCIA VCC/VPP Power-Switching Networks

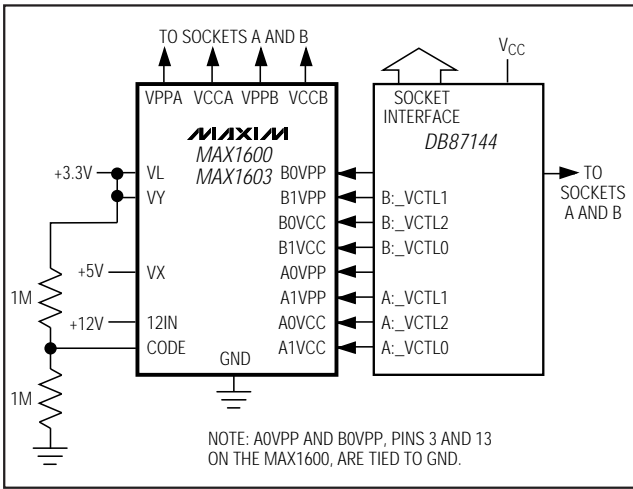
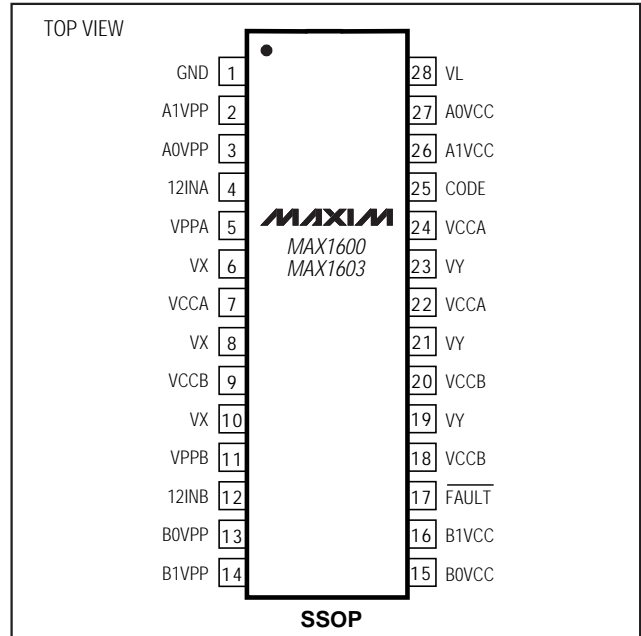

Figure 6. Block Diagram of the Databook DB87144 PCI to CardBus Controller Interface to the MAX1600.

Pin Configuration



Chip Information

TRANSISTOR COUNT: 4372

Package Information

DIM	INCHES		MILLIMETERS	
	MIN	MAX	MIN	MAX
A	0.068	0.078	1.73	1.99
A1	0.002	0.008	0.05	0.21
B	0.010	0.015	0.25	0.38
C	0.004	0.008	0.09	0.20
D	SEE VARIATIONS			
E	0.205	0.209	5.20	5.38
e	0.0256 BSC		0.65 BSC	
H	0.301	0.311	7.65	7.90
L	0.025	0.037	0.63	0.95
α	0°		8°	

D	INCHES		MILLIMETERS	
	MIN	MAX	MIN	MAX
D	0.239	0.249	6.07	6.33
D	0.239	0.249	6.07	6.33
D	0.278	0.289	7.07	7.33
D	0.317	0.328	8.07	8.33
D	0.397	0.407	10.07	10.33

NOTES:
 1. D&E DO NOT INCLUDE MOLD FLASH.
 2. MOLD FLASH OR PROTRUSIONS NOT TO EXCEED .15mm (.006")
 3. CONTROLLING DIMENSION: MILLIMETER

MAXIM
 PROPRIETARY INFORMATION
 TITLE: PACKAGE OUTLINE, SSOP, 5.3X.65mm
 APPROVAL: _____ DOCUMENT CONTROL NO: 21-0056 REV: A 1/1

Maxim cannot assume responsibility for use of any circuitry other than circuitry entirely embodied in a Maxim product. No circuit patent licenses are implied. Maxim reserves the right to change the circuitry and specifications without notice at any time.

12 Maxim Integrated Products, 120 San Gabriel Drive, Sunnyvale, CA 94086 408-737-7600

Looking for pricing, stock, or lifecycle information?

Click below to explore more details on WIN SOURCE:

 [View MAX1603EAI on WIN SOURCE](#)

 [Maxim Integrated Information](#)

Optimize Your Supply Chain with WIN SOURCE Solutions

-  Global Sourcing Solution
-  Obsolete Management
-  Cost Control Management
-  Shortage Management
-  Alternative Solution
-  Excess Inventory Management