

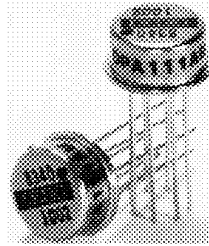

# THE DATASHEET OF OPA111BM





OPA111

## Low Noise Precision *Difet*<sup>®</sup> OPERATIONAL AMPLIFIER

### FEATURES

- **LOW NOISE:** 100% Tested,  $8\text{nV}\sqrt{\text{Hz}}$  max (10kHz)
- **LOW BIAS CURRENT:** 1pA max
- **LOW OFFSET:** 250 $\mu\text{V}$  max
- **LOW DRIFT:** 1 $\mu\text{V}/^\circ\text{C}$  max
- **HIGH OPEN-LOOP GAIN:** 120dB min
- **HIGH COMMON-MODE REJECTION:** 100dB min

### DESCRIPTION

The OPA111 is a precision monolithic dielectrically isolated FET (*Difet*<sup>®</sup>) operational amplifier. Outstanding performance characteristics allow its use in the most critical instrumentation applications.

Noise, bias current, voltage offset, drift, open-loop gain, common-mode rejection, and power supply rejection are superior to BIFET<sup>®</sup> amplifiers.

Very low bias current is obtained by dielectric isolation with on-chip guarding.

Laser trimming of thin-film resistors gives very low offset and drift. Extremely low noise is achieved with patented circuit design techniques. A new cascode design allows high precision input specifications and reduced susceptibility to flicker noise.

Standard 741 pin configuration allows upgrading of existing designs to higher performance levels.

### APPLICATIONS

- **PRECISION INSTRUMENTATION**
- **DATA ACQUISITION**
- **TEST EQUIPMENT**
- **OPTOELECTRONICS**
- **MEDICAL EQUIPMENT—CAT SCANNER**
- **RADIATION HARD EQUIPMENT**

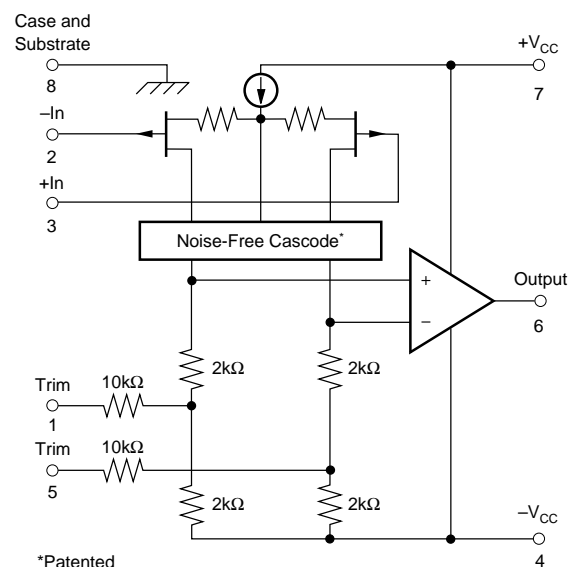

BIFET<sup>®</sup> National Semiconductor Corp., *Difet*<sup>®</sup> Burr-Brown Corp.

International Airport Industrial Park • Mailing Address: PO Box 11400 • Tucson, AZ 85734 • Street Address: 6730 S. Tucson Blvd. • Tucson, AZ 85706  
Tel: (520) 746-1111 • Twx: 910-952-1111 • Cable: BBRCORP • Telex: 066-6491 • FAX: (520) 889-1510 • Immediate Product Info: (800) 548-6132

# SPECIFICATIONS

## ELECTRICAL

At  $V_{CC} = \pm 15\text{VDC}$  and  $T_A = +25^\circ\text{C}$  unless otherwise noted.

PARAMETER	CONDITION	OPA111AM			OPA111BM			OPA111SM			UNITS
		MIN	TYP	MAX	MIN	TYP	MAX	MIN	TYP	MAX	
<b>INPUT</b>											
<b>NOISE</b>											
Voltage, $f_O = 10\text{Hz}$	100% Tested		40	80		30	60		40	80	$\text{nV}/\sqrt{\text{Hz}}$
$f_O = 100\text{Hz}$	100% Tested		15	40		11	30		15	40	$\text{nV}/\sqrt{\text{Hz}}$
$f_O = 1\text{kHz}$	100% Tested		8	15		7	12		8	15	$\text{nV}/\sqrt{\text{Hz}}$
$f_O = 10\text{kHz}$	100% Tested		6	8		6	8		6	8	$\text{nV}/\sqrt{\text{Hz}}$
$f_B = 10\text{Hz}$ to $10\text{kHz}$	100% Tested		0.7	1.2		0.6	1		0.7	1.2	$\mu\text{Vrms}$
Current, $f_B = 0.1\text{Hz}$ to $10\text{Hz}$	(1)		1.6	3.3		1.2	2.5		1.6	3.3	$\mu\text{Vp-p}$
Current, $f_B = 0.1\text{Hz}$ to $10\text{Hz}$	(1)		9.5	15		7.5	12		9.5	15	$\text{fAp-p}$
$f_O = 0.1\text{Hz}$ thru $20\text{kHz}$	(1)		0.5	0.8		0.4	0.6		0.5	0.8	$\text{fA}/\sqrt{\text{Hz}}$
<b>OFFSET VOLTAGE<sup>(2)</sup></b>											
Input Offset Voltage	$V_{CM} = 0\text{VDC}$		$\pm 100$	$\pm 500$		$\pm 50$	$\pm 250$		$\pm 100$	$\pm 500$	$\mu\text{V}$
Average Drift	$T_A = T_{MIN}$ to $T_{MAX}$		$\pm 2$	$\pm 5$		$\pm 0.5$	$\pm 1$		$\pm 2$	$\pm 5$	$\mu\text{V}/^\circ\text{C}$
Supply Rejection	$V_{CC} = \pm 10\text{V}$ to $\pm 18\text{V}$	90	110	$\pm 31$	100	110	$\pm 10$	90	110	$\pm 31$	$\text{dB}$ $\mu\text{V/V}$
<b>BIAS CURRENT<sup>(2)</sup></b>											
Input Bias Current	$V_{CM} = 0\text{VDC}$		$\pm 0.8$	$\pm 2$		$\pm 0.5$	$\pm 1$		$\pm 0.8$	$\pm 2$	$\text{pA}$
<b>OFFSET CURRENT<sup>(2)</sup></b>											
Input Offset Current	$V_{CM} = 0\text{VDC}$		$\pm 0.5$	$\pm 1.5$		$\pm 0.25$	$\pm 0.75$		$\pm 0.5$	$\pm 1.5$	$\text{pA}$
<b>IMPEDANCE</b>											
Differential			$10^{13} \parallel 1$			$10^{13} \parallel 1$			$10^{13} \parallel 1$		$\Omega \parallel \text{pF}$
Common-Mode			$10^{14} \parallel 3$			$10^{14} \parallel 3$			$10^{14} \parallel 3$		$\Omega \parallel \text{pF}$
<b>VOLTAGE RANGE</b>											
Common-Mode Input Range		$\pm 10$	$\pm 11$		$\pm 10$	$\pm 11$		$\pm 10$	$\pm 11$		$\text{V}$
Common-Mode Rejection	$V_{IN} = \pm 10\text{VDC}$	90	110		100	110		90	110		$\text{dB}$
<b>OPEN-LOOP GAIN, DC</b>											
Open-Loop Voltage Gain	$R_L \geq 2\text{k}\Omega$	114	125		120	125		114	125		$\text{dB}$
<b>FREQUENCY RESPONSE</b>											
Unity Gain, Small Signal			2			2			2		$\text{MHz}$
Full Power Response	$20\text{Vp-p}$ , $R_L = 2\text{k}\Omega$	16	32		16	32		16	32		$\text{kHz}$
Slew Rate	$V_O = \pm 10\text{V}$ , $R_L = 2\text{k}\Omega$	1	2		1	2		1	2		$\text{V}/\mu\text{s}$
Settling Time, 0.1%	Gain = $-1$ , $R_L = 2\text{k}\Omega$		6			6			6		$\mu\text{s}$
0.01%	10V Step		10			10			10		$\mu\text{s}$
Overload Recovery, 50% Overdrive <sup>(3)</sup>	Gain = $-1$		5			5			5		$\mu\text{s}$
<b>RATED OUTPUT</b>											
Voltage Output	$R_L = 2\text{k}\Omega$	$\pm 11$	$\pm 12$		$\pm 11$	$\pm 12$		$\pm 11$	$\pm 12$		$\text{V}$
Current Output	$V_O = \pm 10\text{VDC}$	$\pm 5.5$	$\pm 10$		$\pm 5.5$	$\pm 10$		$\pm 5.5$	$\pm 10$		$\text{mA}$
Output Resistance	DC, Open Loop		100			100			100		$\Omega$
Load Capacitance Stability	Gain = $+1$		1000			1000			1000		$\text{pF}$
Short Circuit Current		10	40		10	40		10	40		$\text{mA}$
<b>POWER SUPPLY</b>											
Rated Voltage			$\pm 15$			$\pm 15$			$\pm 15$		$\text{VDC}$
Voltage Range, Derated Performance		$\pm 5$		$\pm 18$	$\pm 5$		$\pm 18$	$\pm 5$		$\pm 18$	$\text{VDC}$
Current, Quiescent	$I_O = 0\text{mADC}$		2.5	3.5		2.5	3.5		2.5	3.5	$\text{mA}$
<b>TEMPERATURE RANGE</b>											
Specification	Ambient Temp.	$-25$		$+85$	$-25$		$+85$	$-55$		$+125$	$^\circ\text{C}$
Operating	Ambient Temp.	$-55$		$+125$	$-55$		$+125$	$-55$		$+125$	$^\circ\text{C}$
Storage	Ambient Temp.	$-65$		$+150$	$-65$		$+150$	$-65$		$+150$	$^\circ\text{C}$
$\theta_{\text{Junction-Ambient}}$			200			200			200		$^\circ\text{C}/\text{W}$

NOTES: (1) Sample tested—this parameter is guaranteed. (2) Offset voltage, offset current, and bias current are measured with the units fully warmed up. (3) Overload recovery is defined as the time required for the output to return from saturation to linear operation following the removal of a 50% input overdrive.

The information provided herein is believed to be reliable; however, BURR-BROWN assumes no responsibility for inaccuracies or omissions. BURR-BROWN assumes no responsibility for the use of this information, and all use of such information shall be entirely at the user's own risk. Prices and specifications are subject to change without notice. No patent rights or licenses to any of the circuits described herein are implied or granted to any third party. BURR-BROWN does not authorize or warrant any BURR-BROWN product for use in life support devices and/or systems.

## ELECTRICAL (FULL TEMPERATURE RANGE SPECIFICATIONS)

At  $V_{CC} = \pm 15\text{VDC}$  and  $T_A = T_{MIN}$  to  $T_{MAX}$  unless otherwise noted.

PARAMETER	CONDITION	OPA111AM			OPA111BM			OPA111SM			UNITS
		MIN	TYP	MAX	MIN	TYP	MAX	MIN	TYP	MAX	
<b>TEMPERATURE RANGE</b>											
Specification Range	Ambient Temp.	-25		+85	-25		+85	-55		+125	°C
<b>INPUT</b>											
<b>OFFSET VOLTAGE<sup>(1)</sup></b> Input Offset Voltage Average Drift Supply Rejection	$V_{CM} = 0\text{VDC}$ $V_{CC} = \pm 10\text{V to } \pm 18\text{V}$		$\pm 220$ $\pm 2$ 86	$\pm 1000$ $\pm 5$ 100		$\pm 110$ $\pm 0.5$ 90	$\pm 500$ $\pm 1$ 100		$\pm 300$ $\pm 2$ 86	$\pm 1500$ $\pm 5$ 100	$\mu\text{V}$ $\mu\text{V}/^\circ\text{C}$ dB $\mu\text{V/V}$
<b>BIAS CURRENT<sup>(1)</sup></b> Input Bias Current	$V_{CM} = 0\text{VDC}$		$\pm 50$	$\pm 250$		$\pm 30$	$\pm 130$		$\pm 820$	$\pm 4100$	pA
<b>OFFSET CURRENT<sup>(1)</sup></b> Input Offset Current	$V_{CM} = 0\text{VDC}$		$\pm 30$	$\pm 200$		$\pm 15$	$\pm 100$		$\pm 510$	$\pm 3100$	pA
<b>VOLTAGE RANGE</b> Common-Mode Input Range Common-Mode Rejection	$V_{IN} = \pm 10\text{VDC}$	$\pm 10$ 86	$\pm 11$ 100		$\pm 10$ 90	$\pm 11$ 100		$\pm 10$ 86	$\pm 11$ 100		V dB
<b>OPEN-LOOP GAIN, DC</b>											
Open-Loop Voltage Gain	$R_L \geq 2\text{k}\Omega$	110	120		114	120		110	120		dB
<b>RATED OUTPUT</b>											
Voltage Output Current Output Short Circuit Current	$R_L = 2\text{k}\Omega$ $V_O = \pm 10\text{VDC}$ $V_O = 0\text{VDC}$	$\pm 10.5$ $\pm 5.25$ 10	$\pm 11$ $\pm 10$ 40		$\pm 11$ $\pm 5.25$ 10	$\pm 11.5$ $\pm 10$ 40		$\pm 11$ $\pm 5.25$ 10	$\pm 11.5$ $\pm 10$ 40		V mA mA
<b>POWER SUPPLY</b>											
Current, Quiescent	$I_O = 0\text{mADC}$		2.5	3.5		2.5	3.5		2.5	3.5	mA

NOTES: (1) Offset voltage, offset current, and bias current are measured with the units fully warmed up.

## CONNECTION DIAGRAM

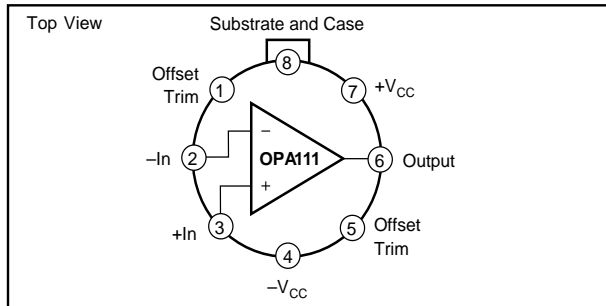

## ABSOLUTE MAXIMUM RATINGS

Supply	±18VDC
Internal Power Dissipation <sup>(1)</sup>	750mW
Differential Input Voltage <sup>(2)</sup>	±36VDC
Input Voltage Range <sup>(2)</sup>	±18VDC
Storage Temperature Range	-65°C to +150°C
Operating Temperature Range	-55°C to +125°C
Lead Temperature (soldering, 10s)	+300°C
Output Short Circuit Duration <sup>(3)</sup>	Continuous
Junction Temperature	+175°C

NOTES: (1) Packages must be derated based on  $\theta_{JC} = 150^\circ\text{C/W}$  or  $\theta_{JA} = 300^\circ\text{C/W}$ . (2) For supply voltages less than  $\pm 18\text{VDC}$ , the absolute maximum input voltage is equal to  $+18\text{V} > V_{IN} > -V_{CC} - 6\text{V}$ . See Figure 2. (3) Short circuit may be to power supply common only. Rating applies to +25°C ambient. Observe dissipation limit and  $T_J$ .

## PACKAGE INFORMATION

MODEL	PACKAGE	PACKAGE DRAWING NUMBER <sup>(1)</sup>
OPA111AM	TO-99	001
OPA111BM	TO-99	001
OPA111SM	TO-99	001

NOTE: (1) For detailed drawing and dimension table, please see end of data sheet, or Appendix D of Burr-Brown IC Data Book.

## ORDERING INFORMATION

MODEL	PACKAGE	TEMPERATURE RANGE	OFFSET VOLTAGE, MAX ( $\mu\text{V}$ )
OPA111AM	TO-99	-25°C to +85°C	±500
OPA111BM	TO-99	-25°C to +85°C	±250
OPA111SM	TO-99	-55°C to +125°C	±500

## DICE INFORMATION

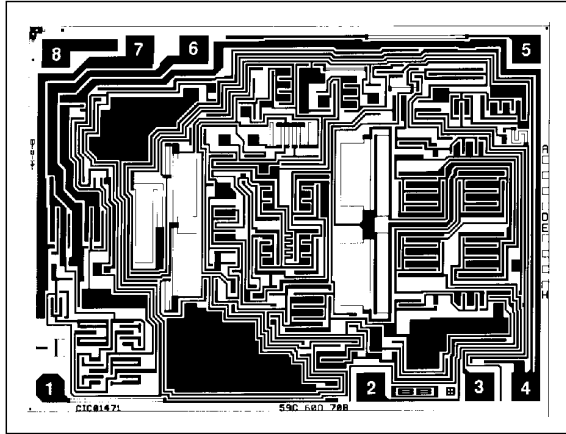

OPA111AD DIE TOPOGRAPHY

PAD	FUNCTION
1	Offset Trim
2	-In
3	+In
4	-V <sub>S</sub>
5	Offset Trim
6	Output
7	+V <sub>S</sub>
8	Substrate

**Substrate Bias:** This Dielectrically-Isolated Substrate is normally connected to common.

## MECHANICAL INFORMATION

	MILS (0.001")	MILLIMETERS
Die Size	95 x 71 ±5	2.41 x 1.80 ±0.13
Die Thickness	20 ±3	0.51 ±0.08
Min. Pad Size	4 x 4	0.10 x 0.10
Backing:	None	
Transistor Count:	44	

## TYPICAL PERFORMANCE CURVES

T<sub>A</sub> = +25°C, V<sub>CC</sub> = ±15VDC unless otherwise noted.

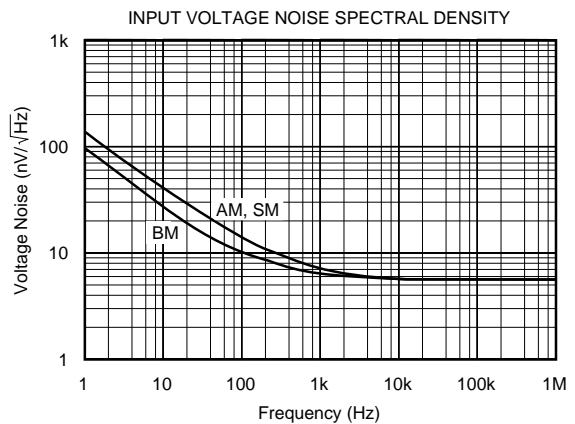
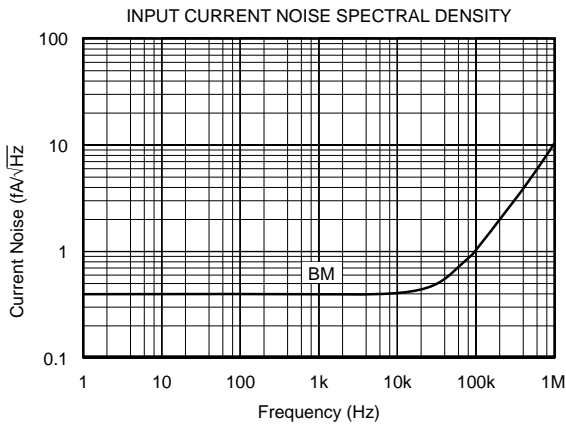

# TYPICAL PERFORMANCE CURVES (CONT)

$T_A = +25^\circ\text{C}$ ,  $V_{OC} = \pm 15\text{VDC}$  unless otherwise noted.

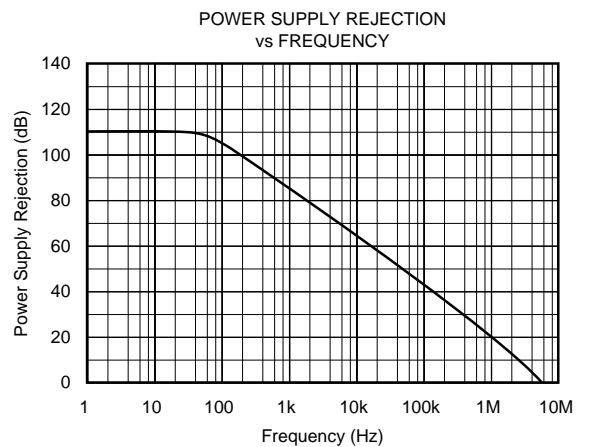
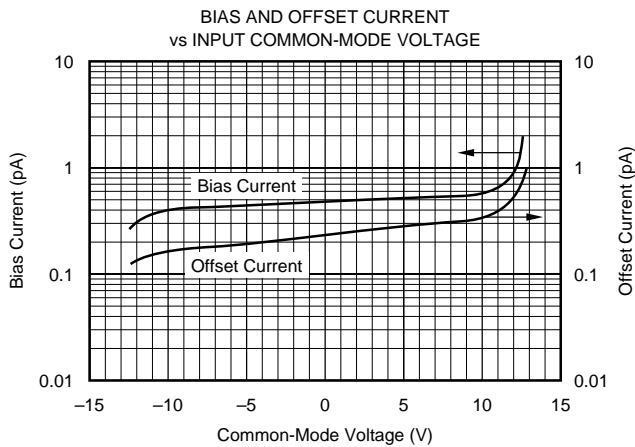
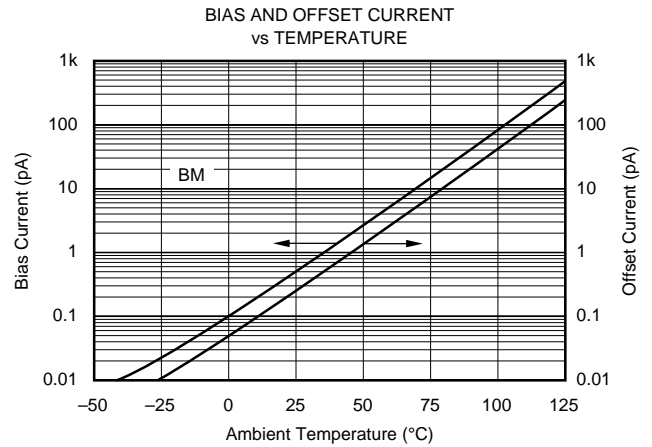
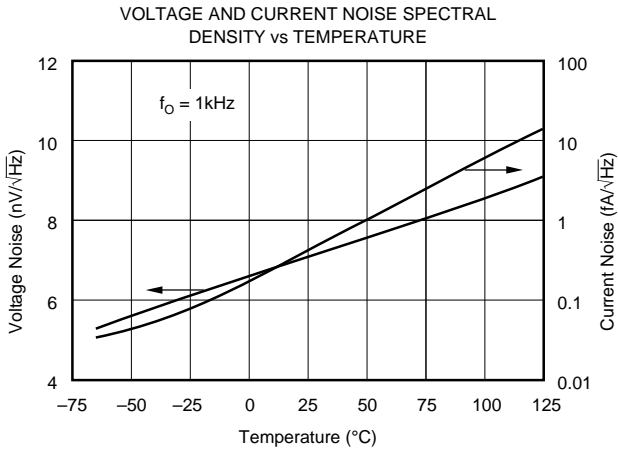
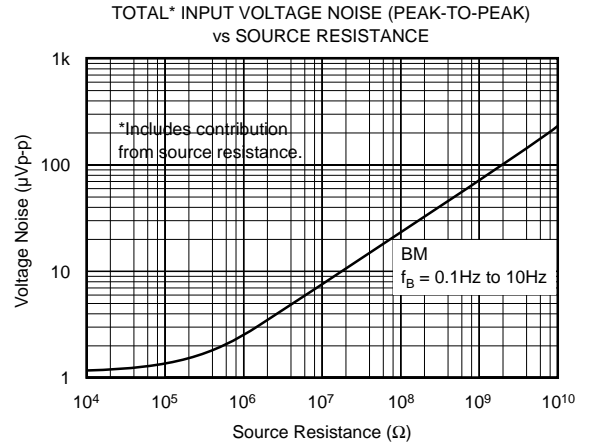
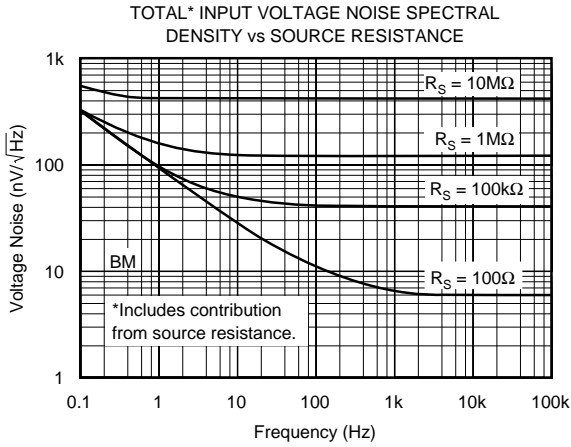

# TYPICAL PERFORMANCE CURVES (CONT)

$T_A = +25^\circ\text{C}$ ,  $V_{CC} = \pm 15\text{VDC}$  unless otherwise noted.

COMMON-MODE REJECTION  
vs FREQUENCY

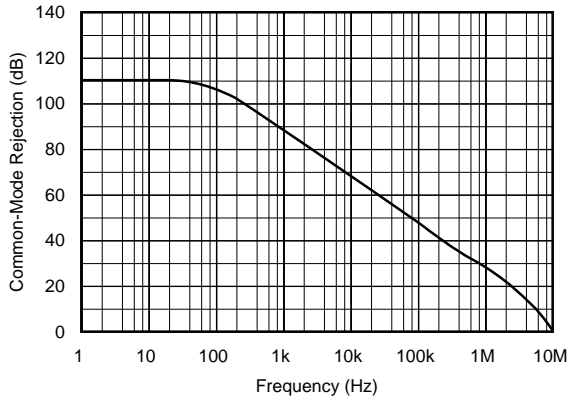

COMMON-MODE REJECTION  
vs INPUT COMMON MODE VOLTAGE

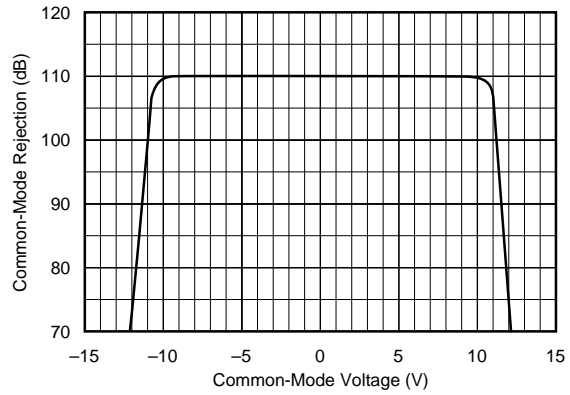

OPEN-LOOP FREQUENCY RESPONSE

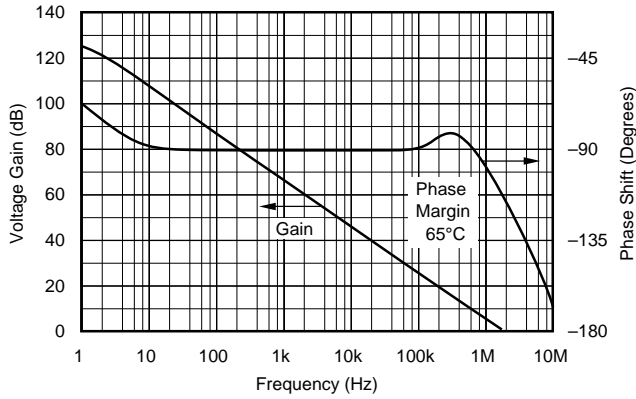

GAIN-BANDWIDTH AND SLEW RATE  
vs TEMPERATURE

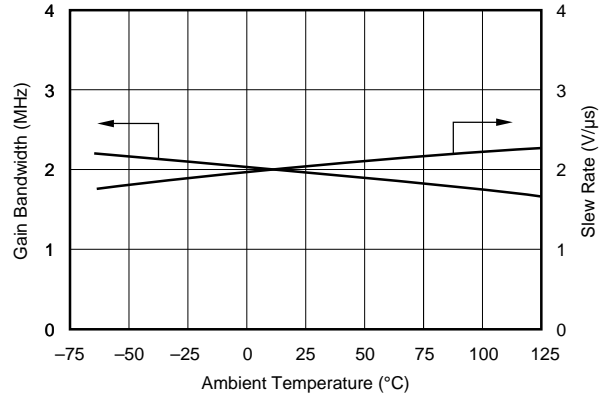

GAIN-BANDWIDTH AND SLEW RATE  
vs SUPPLY VOLTAGE

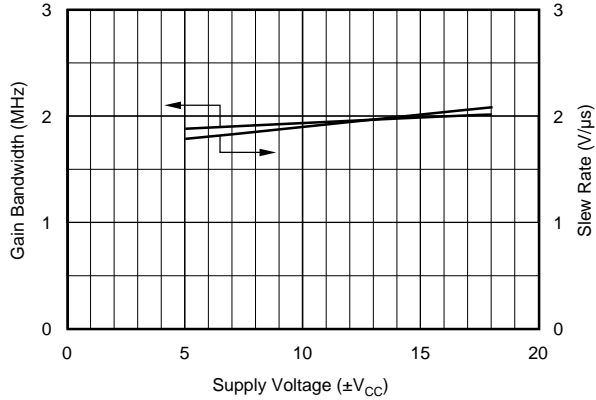

OPEN-LOOP GAIN vs TEMPERATURE

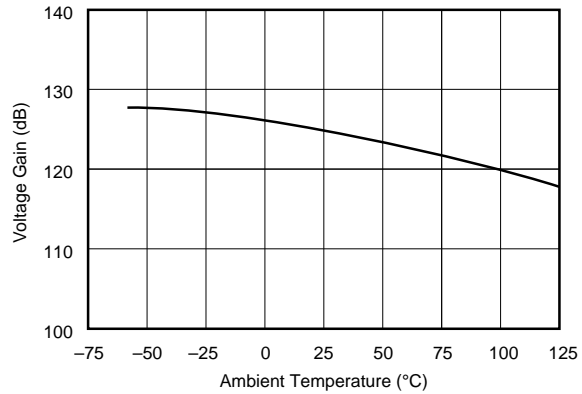

# TYPICAL PERFORMANCE CURVES (CONT)

$T_A = +25^\circ\text{C}$ ,  $V_{CC} = \pm 15\text{VDC}$  unless otherwise noted.

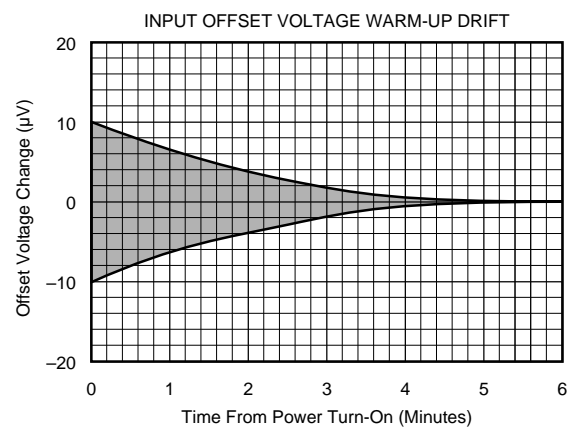
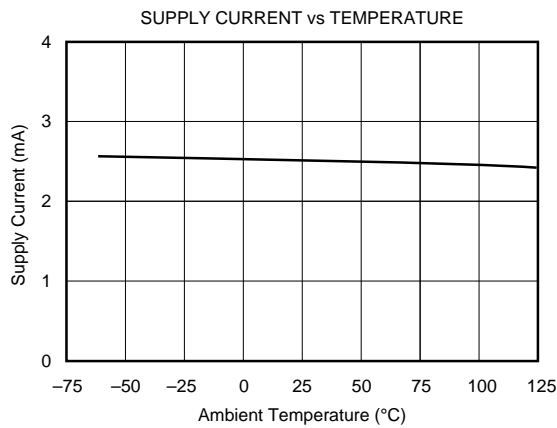
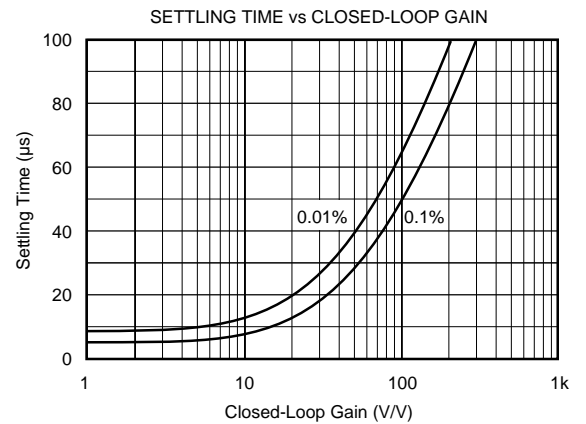
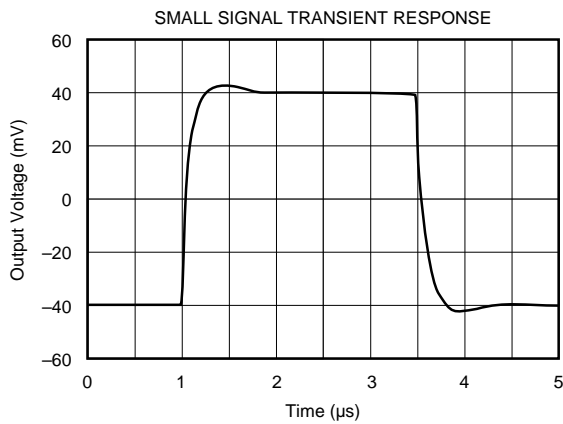
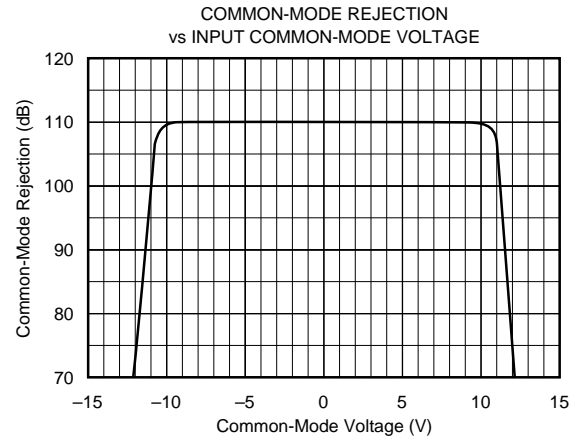
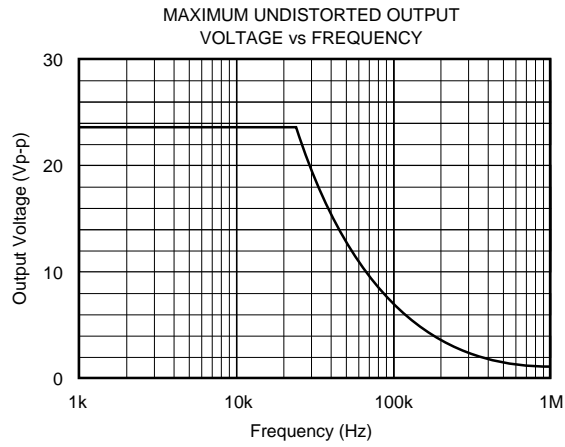

# TYPICAL PERFORMANCE CURVES (CONT)

$T_A = +25^\circ\text{C}$ ,  $V_{CC} = \pm 15\text{VDC}$  unless otherwise noted.

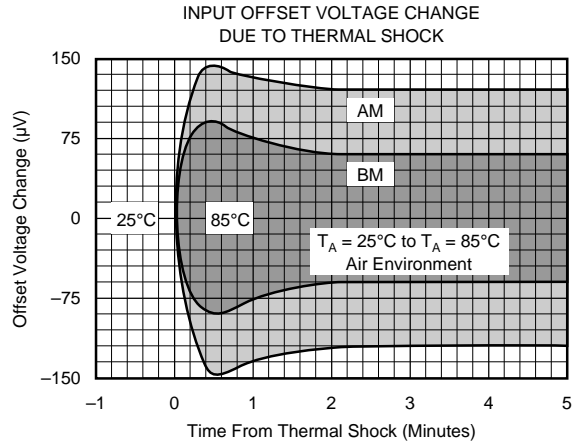

## APPLICATIONS INFORMATION

### OFFSET VOLTAGE ADJUSTMENT

The OPA111 offset voltage is laser-trimmed and will require no further trim for most applications. As with most amplifiers, externally trimming the remaining offset can change drift performance by about  $0.3\mu\text{V}/^\circ\text{C}$  for each  $100\mu\text{V}$  of adjusted offset. Note that the trim (Figure 1) is similar to operational amplifiers such as 741 and AD547. The OPA111 can replace most other amplifiers by leaving the external null circuit unconnected.

### INPUT PROTECTION

Conventional monolithic FET operational amplifiers require external current-limiting resistors to protect their inputs against destructive currents that can flow when input FET gate-to-substrate isolation diodes are forward-biased. Most BIFET amplifiers can be destroyed by the loss of  $-V_{CC}$ .

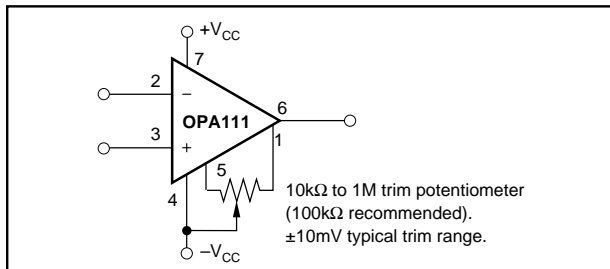

FIGURE 1. Offset Voltage Trim.

Unlike BIFET amplifiers, The *Difet* OPA111 requires input current limiting resistors only if its input voltage is greater than 6V more negative than  $-V_{CC}$ . A  $10\text{k}\Omega$  series resistor will limit input current to a safe level with up to  $\pm 15\text{V}$  input levels, even if both supply voltages are lost.

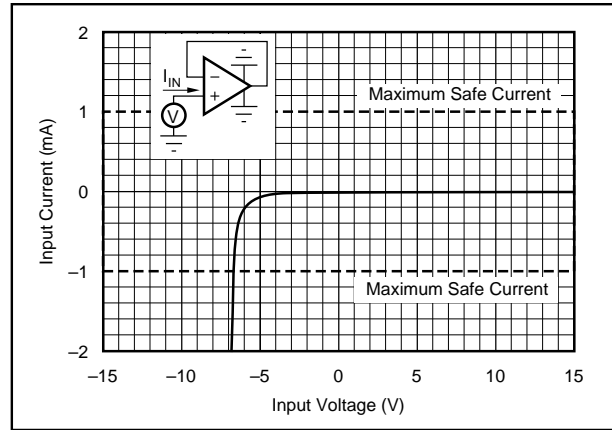

FIGURE 2. Input Current vs Input Voltage with  $\pm V_{CC}$  Pins Grounded.

Static damage can cause subtle changes in amplifier input characteristics without necessarily destroying the device. In precision operational amplifiers (both bipolar and FET types), this may cause a noticeable degradation of offset voltage and drift. Static protection is recommended when handling any precision IC operational amplifier.

### GUARDING AND SHIELDING

As in any situation where high impedances are involved, careful shielding is required to reduce “hum” pickup in input leads. If large feedback resistors are used, they should also be shielded along with the external input circuitry.

Leakage currents across printed circuit boards can easily exceed the bias current of the OPA111. To avoid leakage problems, it is recommended that the signal input lead of the OPA111 be wired to a Teflon standoff. If the OPA111 is to be soldered directly into a printed circuit board, utmost care must be used in planning the board layout. A “guard” pattern

should completely surround the high impedance input leads and should be connected to a low impedance point which is at the signal input potential.

The amplifier case should be connected to any input shield or guard via pin 8. This insures that the amplifier itself is fully surrounded by guard potential, minimizing both leakage and noise pickup (see Figure 3).

If guarding is not required, pin 8 (case) should be connected to ground.

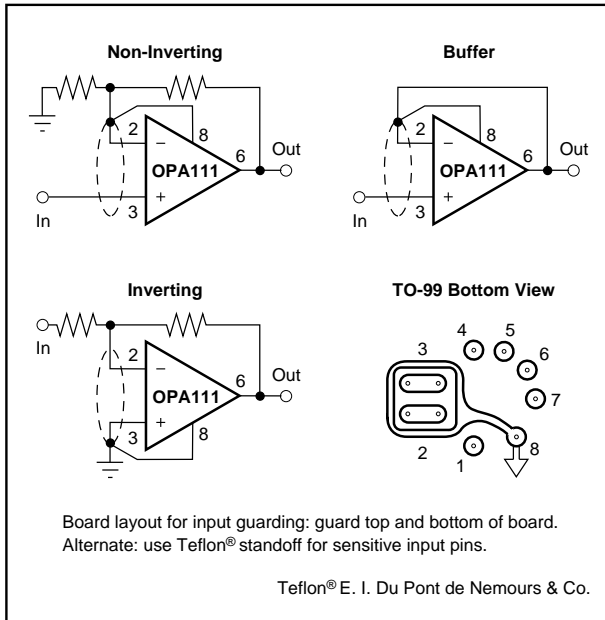

FIGURE 3. Connection of Input Guard.

### NOISE: FET VERSUS BIPOLAR

Low noise circuit design requires careful analysis of all noise sources. External noise sources can dominate in many cases, so consider the effect of source resistance on overall operational amplifier noise performance. At low source impedances, the lower voltage noise of a bipolar operational amplifier is superior, but at higher impedances the high current noise of a bipolar amplifier becomes a serious liability. Above about 15kΩ, the OPA111 will have a lower total noise than an OP-27 (see Figure 4).

### BIAS CURRENT CHANGE VERSUS COMMON-MODE VOLTAGE

The input bias current of most popular BIFET operational amplifiers are affected by common-mode voltage (Figure 5). Higher input FET gate-to-drain voltage causes leakage and ionization (bias) currents to increase. Due to its cascode input stage, the extremely low bias current of the OPA111 is not compromised by common-mode voltage.

### APPLICATIONS CIRCUITS

Figures 6 through 18 are circuit diagrams of various applications for the OPA111.

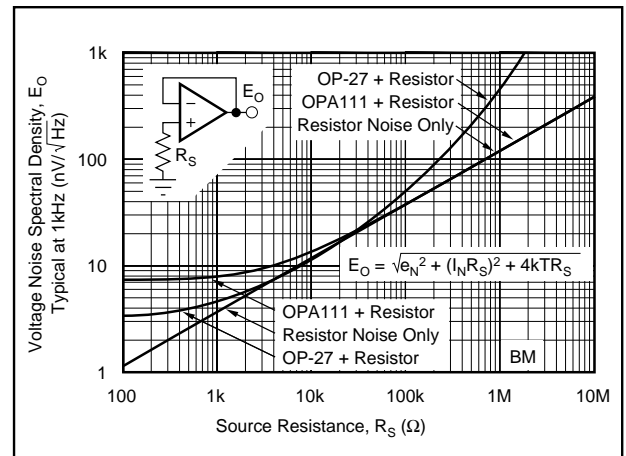

FIGURE 4. Voltage Noise Spectral Density vs Source Resistance.

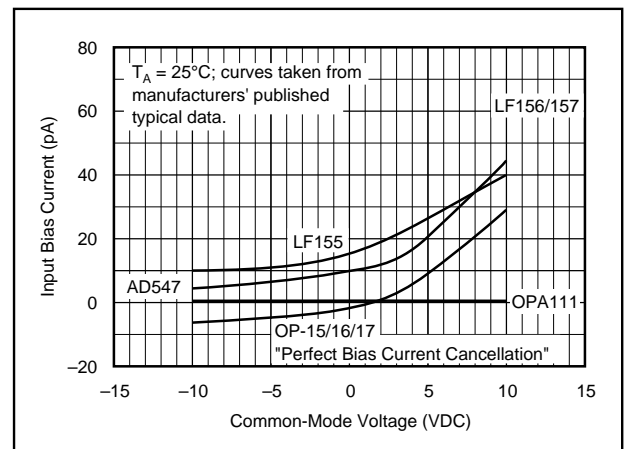

FIGURE 5. Input Bias Current vs Common-Mode Voltage.

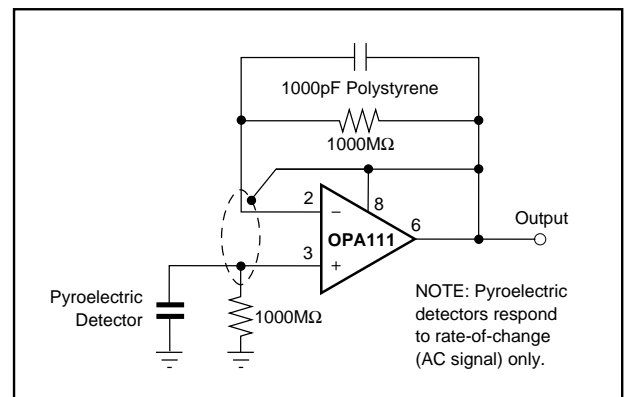

FIGURE 6. Pyroelectric Infrared Detector.

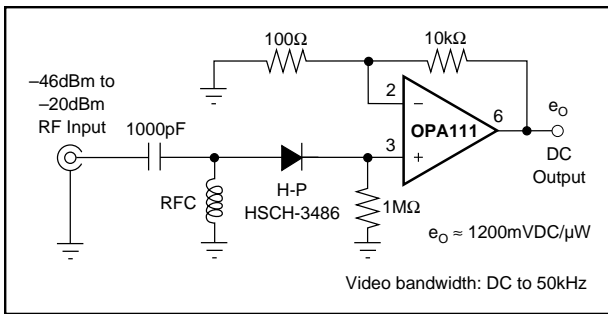

FIGURE 7. Zero-Bias Schottky Diode Square-Law RF Detector.

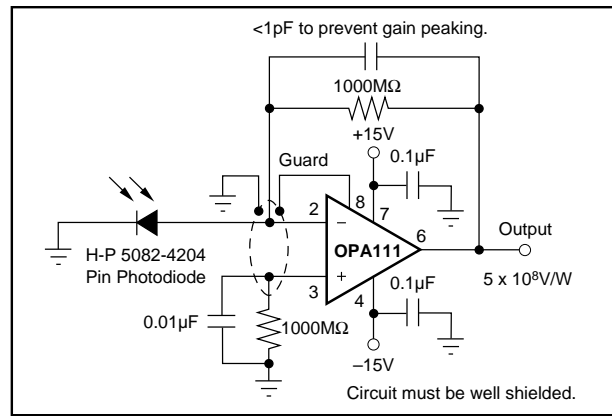

FIGURE 10. Sensitive Photodiode Amplifier.

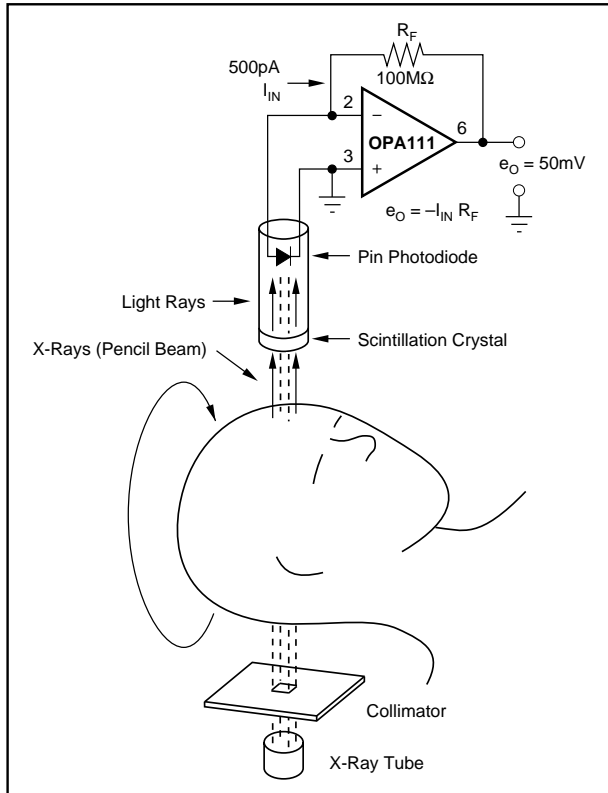

FIGURE 8. Computerized Axial Tomography (CAT) Scanner Channel Amplifier.

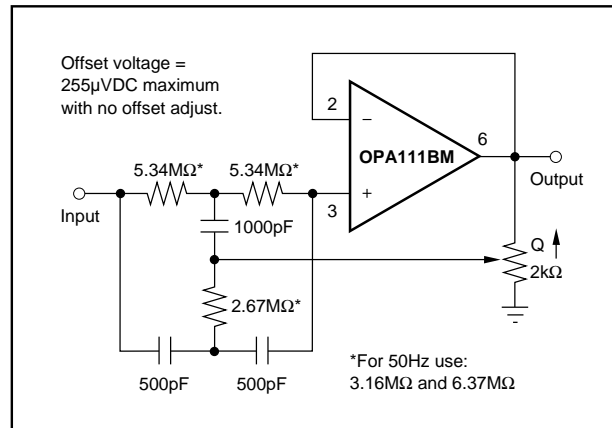

FIGURE 11. 60Hz Reject Filter.

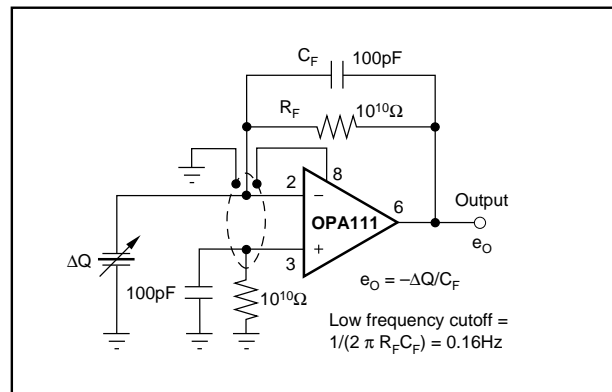

FIGURE 12. Piezoelectric Transducer Charge Amplifier.

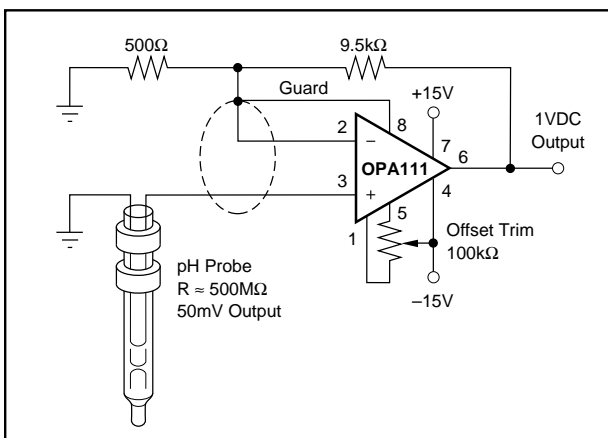

FIGURE 9. High Impedance ( $10^{14}\Omega$ ) Amplifier.

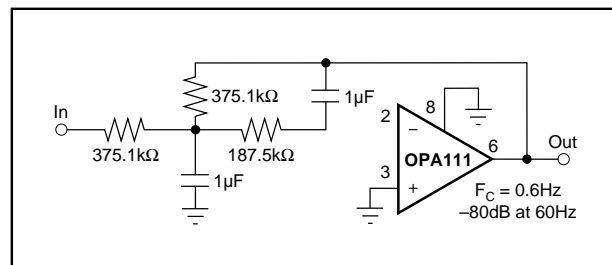

FIGURE 13. 0.6Hz Second-Order Low-Pass Filter.

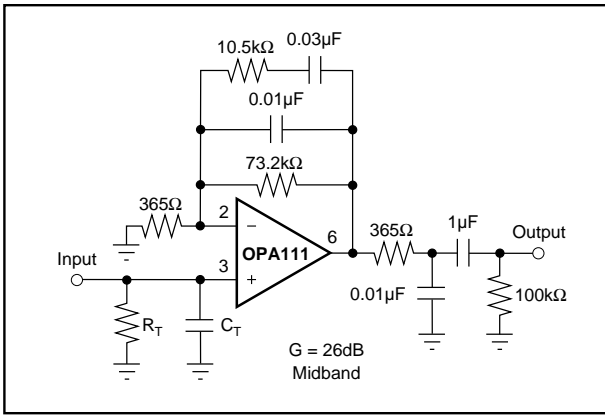

FIGURE 14. RIAA Equalized Phono Preamp.

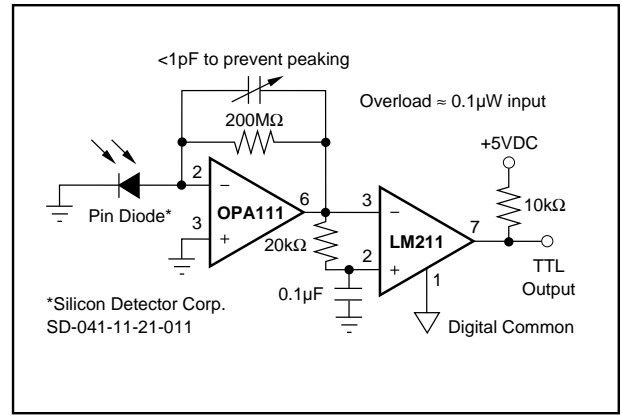

FIGURE 15. High Sensitivity (under 1nW) Fiber Optic Receiver for 9600 Baud Manchester Data.

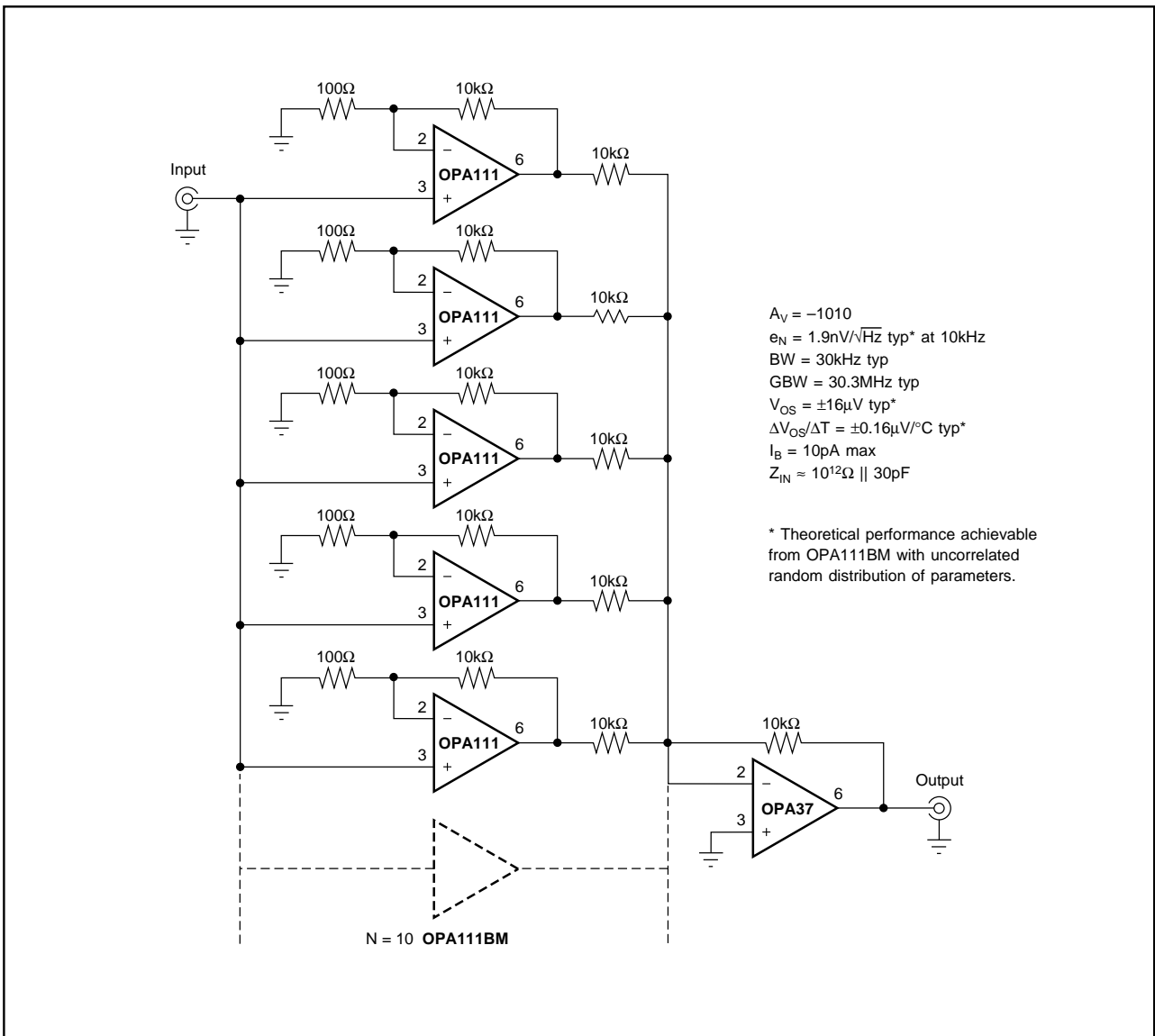

FIGURE 16. 'N' Stage Parallel-Input Amplifier for Reduced Relative Amplifier Noise at the Output.

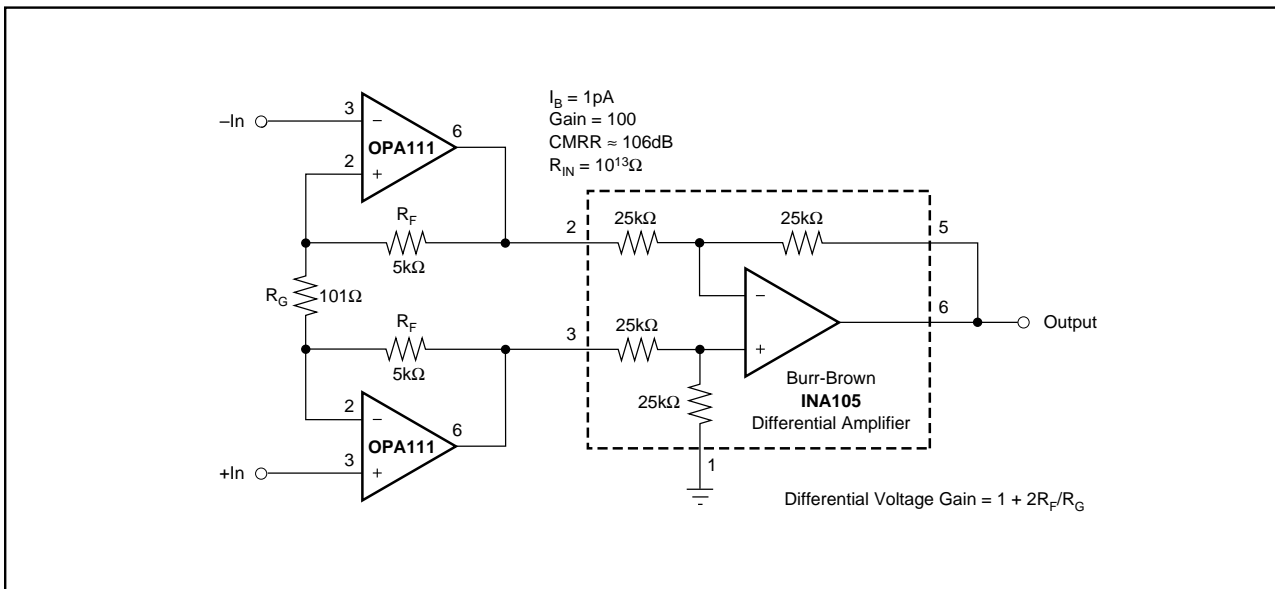

FIGURE 17. FET Input Instrumentation Amplifier.

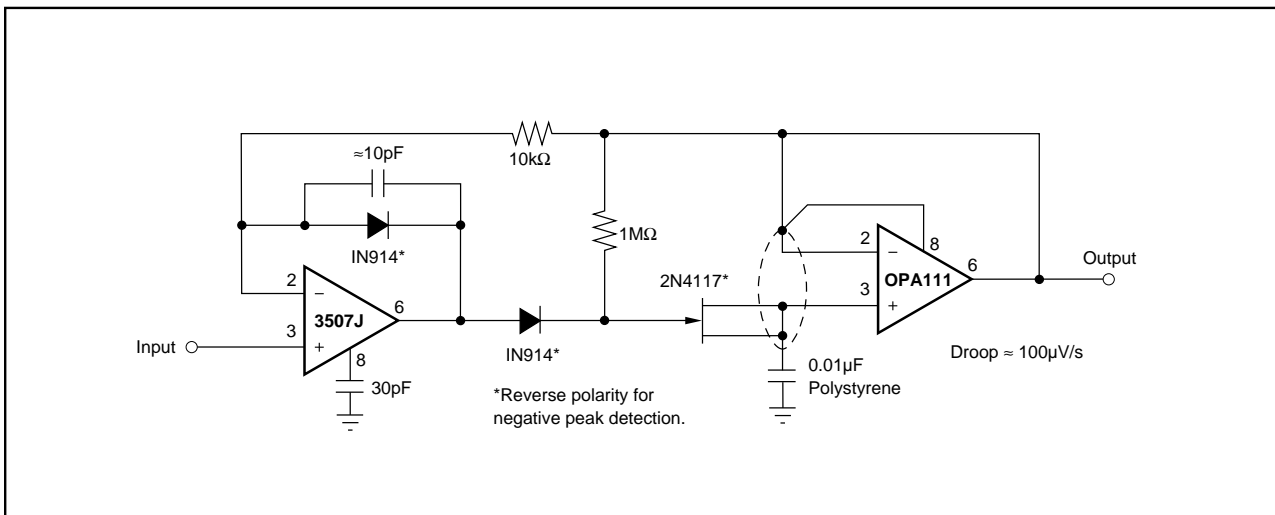

FIGURE 18. Low-Droop Positive Peak Detector.

**PACKAGING INFORMATION**

Orderable Device	Status (1)	Package Type	Package Drawing	Pins	Package Qty	Eco Plan (2)	Lead/Ball Finish (6)	MSL Peak Temp (3)	Op Temp (°C)	Device Marking (4/5)	Samples
OPA111AM	LIFEBUY	TO-99	LMC	8	20	Green (RoHS & no Sb/Br)	AU	N / A for Pkg Type		OPA111AM	
OPA111BM	LIFEBUY	TO-99	LMC	8	1	Green (RoHS & no Sb/Br)	AU	N / A for Pkg Type		OPA111BM	

(1) The marketing status values are defined as follows:

**ACTIVE:** Product device recommended for new designs.

**LIFEBUY:** TI has announced that the device will be discontinued, and a lifetime-buy period is in effect.

**NRND:** Not recommended for new designs. Device is in production to support existing customers, but TI does not recommend using this part in a new design.

**PREVIEW:** Device has been announced but is not in production. Samples may or may not be available.

**OBSOLETE:** TI has discontinued the production of the device.

(2) **RoHS:** TI defines "RoHS" to mean semiconductor products that are compliant with the current EU RoHS requirements for all 10 RoHS substances, including the requirement that RoHS substance do not exceed 0.1% by weight in homogeneous materials. Where designed to be soldered at high temperatures, "RoHS" products are suitable for use in specified lead-free processes. TI may reference these types of products as "Pb-Free".

**RoHS Exempt:** TI defines "RoHS Exempt" to mean products that contain lead but are compliant with EU RoHS pursuant to a specific EU RoHS exemption.

**Green:** TI defines "Green" to mean the content of Chlorine (Cl) and Bromine (Br) based flame retardants meet JS709B low halogen requirements of <=1000ppm threshold. Antimony trioxide based flame retardants must also meet the <=1000ppm threshold requirement.

(3) MSL, Peak Temp. - The Moisture Sensitivity Level rating according to the JEDEC industry standard classifications, and peak solder temperature.

(4) There may be additional marking, which relates to the logo, the lot trace code information, or the environmental category on the device.

(5) Multiple Device Markings will be inside parentheses. Only one Device Marking contained in parentheses and separated by a "~" will appear on a device. If a line is indented then it is a continuation of the previous line and the two combined represent the entire Device Marking for that device.

(6) Lead/Ball Finish - Orderable Devices may have multiple material finish options. Finish options are separated by a vertical ruled line. Lead/Ball Finish values may wrap to two lines if the finish value exceeds the maximum column width.

**Important Information and Disclaimer:**The information provided on this page represents TI's knowledge and belief as of the date that it is provided. TI bases its knowledge and belief on information provided by third parties, and makes no representation or warranty as to the accuracy of such information. Efforts are underway to better integrate information from third parties. TI has taken and continues to take reasonable steps to provide representative and accurate information but may not have conducted destructive testing or chemical analysis on incoming materials and chemicals. TI and TI suppliers consider certain information to be proprietary, and thus CAS numbers and other limited information may not be available for release.

In no event shall TI's liability arising out of such information exceed the total purchase price of the TI part(s) at issue in this document sold by TI to Customer on an annual basis.



## IMPORTANT NOTICE AND DISCLAIMER

TI PROVIDES TECHNICAL AND RELIABILITY DATA (INCLUDING DATASHEETS), DESIGN RESOURCES (INCLUDING REFERENCE DESIGNS), APPLICATION OR OTHER DESIGN ADVICE, WEB TOOLS, SAFETY INFORMATION, AND OTHER RESOURCES "AS IS" AND WITH ALL FAULTS, AND DISCLAIMS ALL WARRANTIES, EXPRESS AND IMPLIED, INCLUDING WITHOUT LIMITATION ANY IMPLIED WARRANTIES OF MERCHANTABILITY, FITNESS FOR A PARTICULAR PURPOSE OR NON-INFRINGEMENT OF THIRD PARTY INTELLECTUAL PROPERTY RIGHTS.

These resources are intended for skilled developers designing with TI products. You are solely responsible for (1) selecting the appropriate TI products for your application, (2) designing, validating and testing your application, and (3) ensuring your application meets applicable standards, and any other safety, security, or other requirements. These resources are subject to change without notice. TI grants you permission to use these resources only for development of an application that uses the TI products described in the resource. Other reproduction and display of these resources is prohibited. No license is granted to any other TI intellectual property right or to any third party intellectual property right. TI disclaims responsibility for, and you will fully indemnify TI and its representatives against, any claims, damages, costs, losses, and liabilities arising out of your use of these resources.

TI's products are provided subject to TI's Terms of Sale ([www.ti.com/legal/termsofsale.html](http://www.ti.com/legal/termsofsale.html)) or other applicable terms available either on [ti.com](http://ti.com) or provided in conjunction with such TI products. TI's provision of these resources does not expand or otherwise alter TI's applicable warranties or warranty disclaimers for TI products.

Mailing Address: Texas Instruments, Post Office Box 655303, Dallas, Texas 75265  
Copyright © 2019, Texas Instruments Incorporated

## Looking for pricing, stock, or lifecycle information?

Click below to explore more details on WIN SOURCE:

 [View OPA111BM](#) on WIN SOURCE

 [Texas Instruments](#) Information

## Optimize Your Supply Chain with WIN SOURCE Solutions

-  Global Sourcing Solution
-  Obsolete Management
-  Cost Control Management
-  Shortage Management
-  Alternative Solution
-  Excess Inventory Management