

Features

- Low $V_{CE(on)}$ Planar IGBT Technology
- Low Switching Losses
- Square RBSOA
- 100% of the Parts Tested for ILM
- Positive $V_{CE(on)}$ Temperature Coefficient
- Reflow Capable per JDS22-A113
- Lead-Free, RoHS Compliant
- Automotive Qualified *

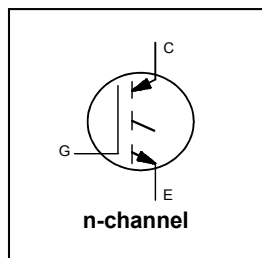

$V_{CES} = 1200V$
 $I_C = 81A @ T_C = 100^\circ C$
 $V_{CE(on)} \text{ typ.} = 1.47V @ 33A$

Benefits

- Device optimized for soft switching applications
- High Efficiency due to Low $V_{CE(on)}$, low switching losses
- Rugged transient performance for increased reliability
- Excellent current sharing in parallel operation
- Low EMI

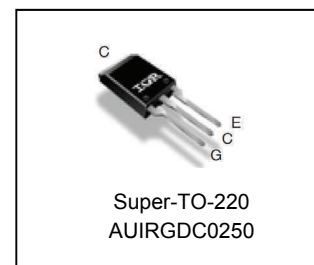

G	C	E
Gate	Collector	Emitter

Application

- PTC Heater
- Relay Replacement

Base Part Number	Package Type	Standard Pack		Orderable Part Number
		Form	Quantity	
AUIRGDC0250	Super-TO-220	Tube	50	AUIRGDC0250

Absolute Maximum Ratings

Stresses beyond those listed under “Absolute Maximum Ratings” may cause permanent damage to the device. These are stress ratings only; and functional operation of the device at these or any other condition beyond those indicated in the specifications is not implied. Exposure to absolute-maximum-rated conditions for extended periods may affect device reliability. The thermal resistance and power dissipation ratings are measured under board mounted and still air conditions. Ambient temperature (T_A) is $25^\circ C$, unless otherwise specified.

	Parameter	Max.	Units
V_{CES}	Collector-to-Emitter Voltage	1200	V
$I_C @ T_C = 25^\circ C$	Continuous Collector Current	141 ^④	A
$I_C @ T_C = 100^\circ C$	Continuous Collector Current	81	
I_{CM}	Pulse Collector Current, $V_{GE} = 15V$ ^②	99	
I_{LM}	Clamped Inductive Load Current, $V_{GE} = 20V$ ^①	99	V
V_{GE}	Continuous Gate-to-Emitter Voltage	± 20	
	Transient Gate-to-Emitter Voltage	± 30	
$P_D @ T_C = 25^\circ C$	Maximum Power Dissipation	543	W
$P_D @ T_C = 100^\circ C$	Maximum Power Dissipation	217	
T_J	Operating Junction and	-55 to +150	$^\circ C$
T_{STG}	Storage Temperature Range		
	Soldering Temperature, for 10 sec. (Through Hole Mounting)	300 (0.063 in. (1.6mm) from case)	

Thermal Resistance

	Parameter	Typ.	Max.	Units
$R_{\theta JC}$ (IGBT)	Thermal Resistance Junction-to-Case (each IGBT) ^③	—	0.23	$^\circ C/W$
$R_{\theta CS}$	Thermal Resistance, Case-to-Sink (flat, greased surface)	0.50	—	
$R_{\theta JA}$	Thermal Resistance, Junction-to-Ambient (typical socket mount)	—	62	

* Qualification standards can be found at www.infineon.com

Electrical Characteristics @ T_J = 25°C (unless otherwise specified)

	Parameter	Min.	Typ.	Max.	Units	Conditions
V _{(BR)CES}	Collector-to-Emitter Breakdown Voltage	1200	—	—	V	V _{GE} = 0V, I _C = 250μA
ΔV _{(BR)CES} /ΔT _J	Temperature Coeff. of Breakdown Voltage	—	1.2	—	V/°C	V _{GE} = 0V, I _C = 1mA (25°C-150°C)
V _{CE(on)}	Collector-to-Emitter Saturation Voltage	—	1.47	1.8	V	I _C = 33A, V _{GE} = 15V, T _J = 25°C
		—	1.56	—		I _C = 33A, V _{GE} = 15V, T _J = 150°C
V _{GE(th)}	Gate Threshold Voltage	3.0	—	6.0	V	V _{CE} = V _{GE} , I _C = 250μA
ΔV _{GE(th)} /ΔT _J	Threshold Voltage temp. coefficient	—	-15	—	mV/°C	V _{CE} = V _{GE} , I _C = 250μA (25°C-150°C)
g _{fe}	Forward Transconductance	—	30	—	S	V _{CE} = 50V, I _C = 33A, PW = 20μS
I _{CES}	Collector-to-Emitter Leakage Current	—	—	250	μA	V _{GE} = 0V, V _{CE} = 1200V, T _J = 25°C
		—	—	1000		V _{GE} = 0V, V _{CE} = 1200V, T _J = 150°C
I _{GES}	Gate-to-Emitter Leakage Current	—	—	±100	nA	V _{GE} = ±20V

Switching Characteristics @ T_J = 25°C (unless otherwise specified)

	Parameter	Min.	Typ.	Max.	Units	Conditions
Q _g	Total Gate Charge (turn-on)	—	151	227	nC	I _C = 33A V _{GE} = 15V V _{CC} = 600V
Q _{ge}	Gate-to-Emitter Charge (turn-on)	—	26	39		
Q _{gc}	Gate-to-Collector Charge (turn-on)	—	62	93		
E _{off}	Turn-Off Switching Loss	—	15	16	mJ	I _C = 33A, V _{CC} = 600V, V _{GE} = 15V
t _{d(off)}	Turn-Off delay time	—	485	616	ns	R _G = 5Ω, L = 400μH, T _J = 25°C Energy losses include tail
t _f	Fall time	—	1193	1371		
E _{off}	Turn-Off Switching Loss	—	29	—	mJ	I _C = 33A, V _{CC} = 600V, V _{GE} = 15V
t _{d(off)}	Turn-Off delay time	—	689	—	ns	R _G = 5Ω, L = 400μH, T _J = 150°C Energy losses include tail
t _f	Fall time	—	2462	—		
C _{ies}	Input Capacitance	—	3804	—	pF	V _{GE} = 0V V _{CC} = 30V f = 1.0Mhz
C _{oes}	Output Capacitance	—	161	—		
C _{res}	Reverse Transfer Capacitance	—	31	—		
RBSOA	Reverse Bias Safe Operating Area	FULL SQUARE				T _J = 150°C, I _C = 99A V _{CC} = 960V, V _p ≤ 1200V R _g = 5Ω, V _{GE} = +20V to 0V

Notes:

- ① V_{CC} = 80% (V_{CES}), V_{GE} = 20V, L = 400μH, R_G = 5Ω.
- ② Pulse width limited by max. junction temperature.
- ③ R_θ is measured at T_J approximately 90°C.
- ④ Calculated continuous current based on maximum allowable junction temperature. Bond wire current limit is 78A.
Note that current limitations arising from heating of the device leads may occur with some lead mounting arrangements.

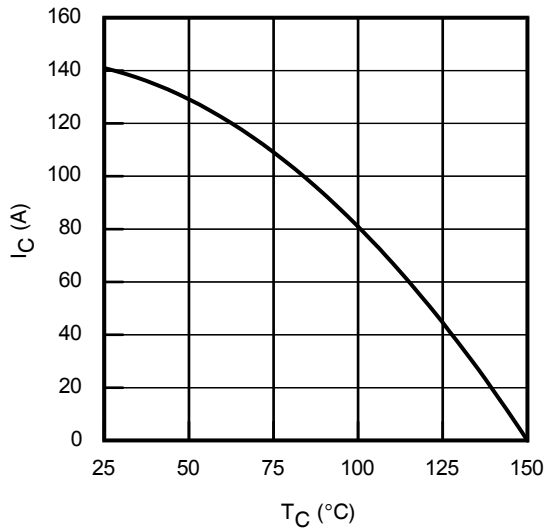

Fig. 1 - Maximum DC Collector Current vs. Case Temperature

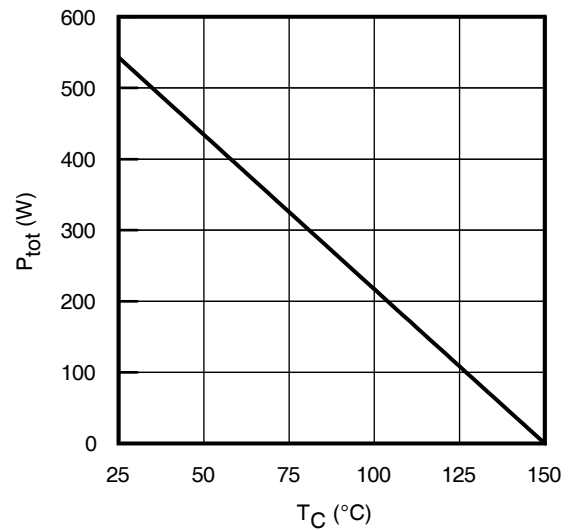

Fig. 2 - Power Dissipation vs. Case Temperature

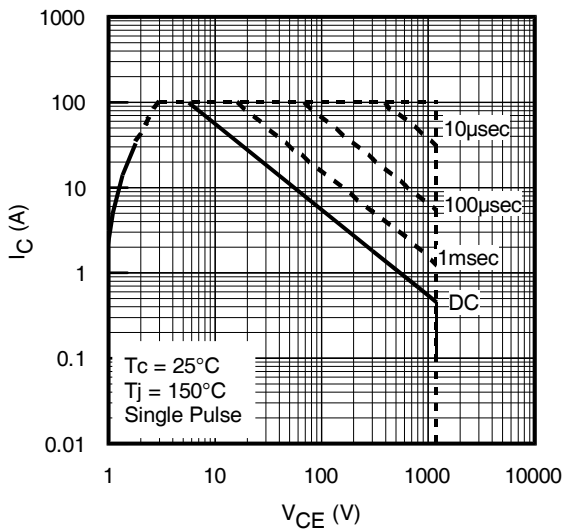

Fig. 3 - Forward SOA
 $T_C = 25^\circ\text{C}$, $T_J \leq 150^\circ\text{C}$; $V_{GE} = 15\text{V}$

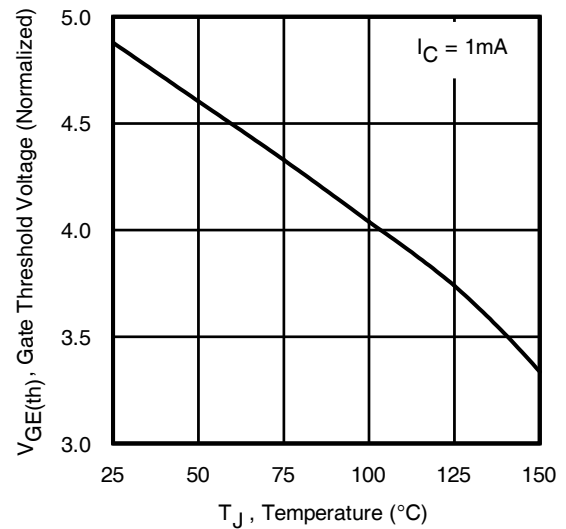

Fig. 4 - Typical Gate Threshold Voltage (Normalized) vs. Junction Temperature

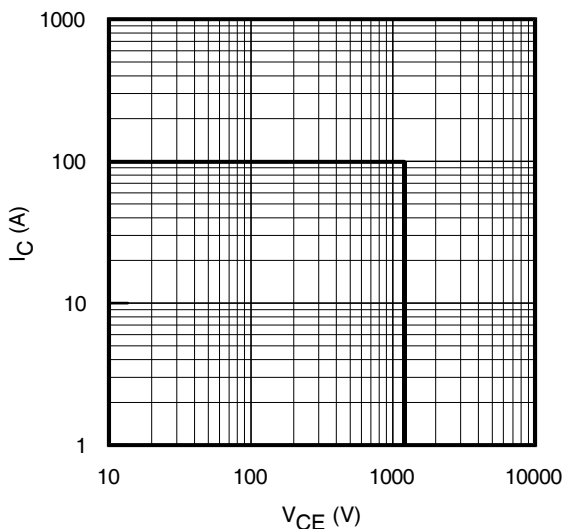

Fig. 5 - Reverse Bias SOA
 $T_J = 150^\circ\text{C}$; $V_{GE} = 20\text{V}$

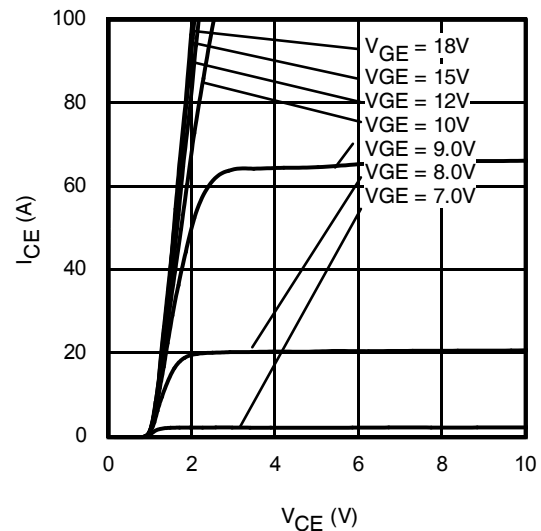

Fig. 6 - Typ. IGBT Output Characteristics
 $T_J = -40^\circ\text{C}$; $t_p = 20\mu\text{s}$

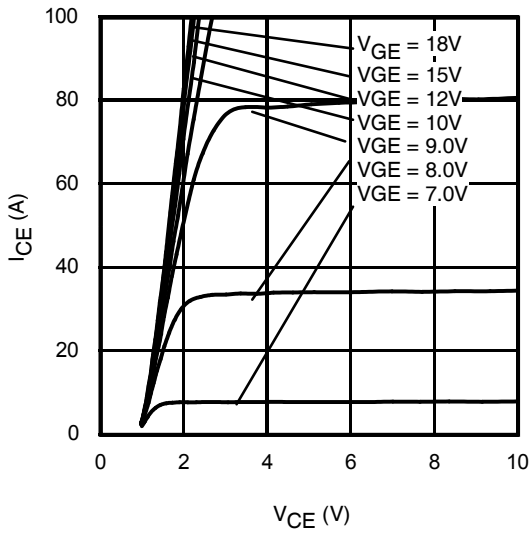

Fig. 7 - Typ. IGBT Output Characteristics
 $T_J = 25^\circ\text{C}$; $t_p = 20\mu\text{s}$

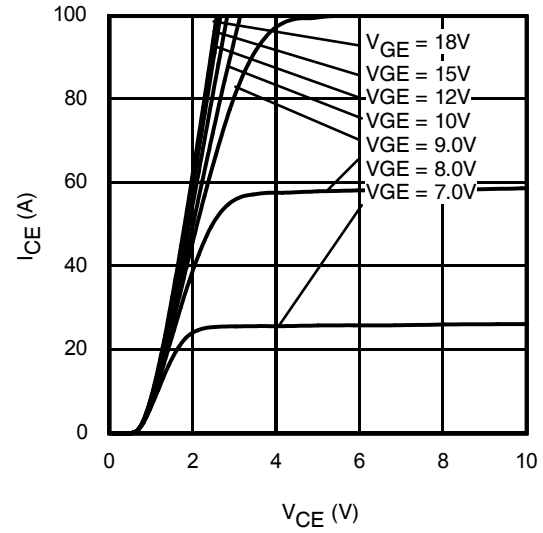

Fig. 8 - Typ. IGBT Output Characteristics
 $T_J = 150^\circ\text{C}$; $t_p = 20\mu\text{s}$

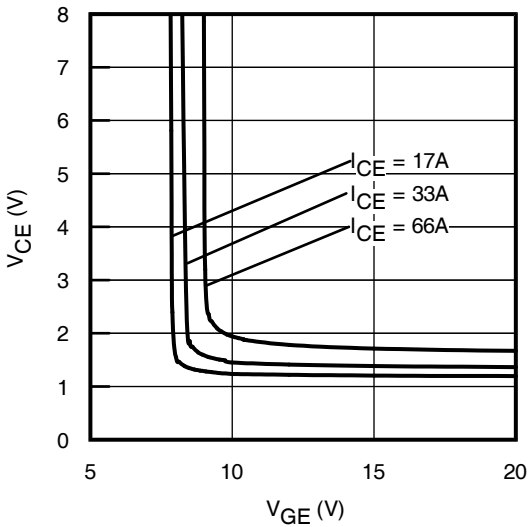

Fig. 9 - Typical V_{CE} vs. V_{GE}
 $T_J = -40^\circ\text{C}$

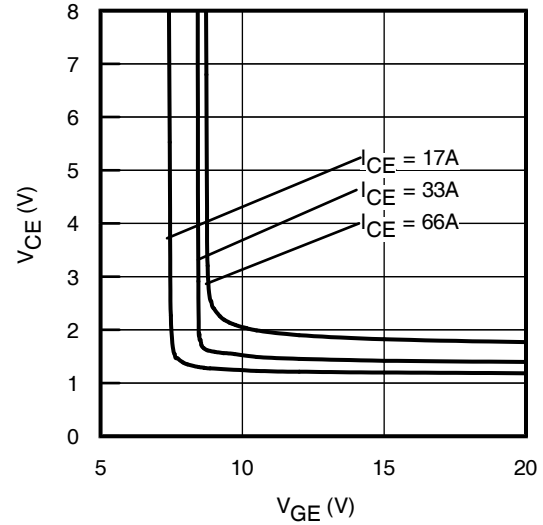

Fig. 10 - Typical V_{CE} vs. V_{GE}
 $T_J = 25^\circ\text{C}$

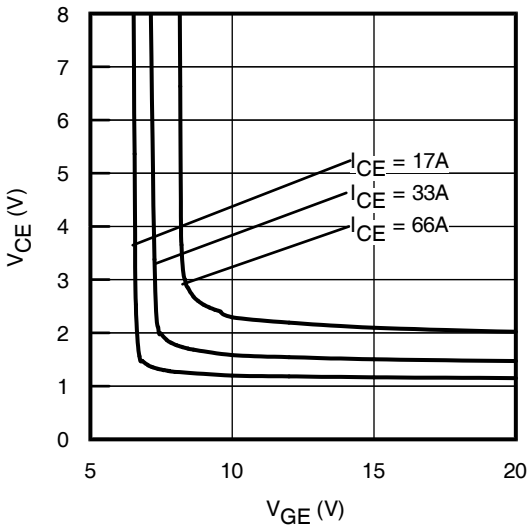

Fig. 11 - Typical V_{CE} vs. V_{GE}
 $T_J = 150^\circ\text{C}$

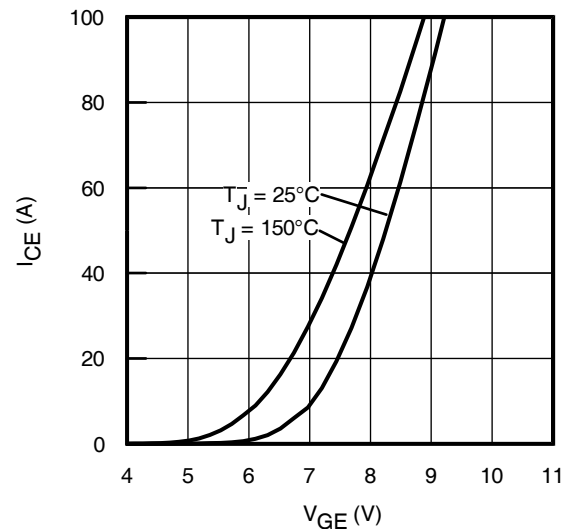
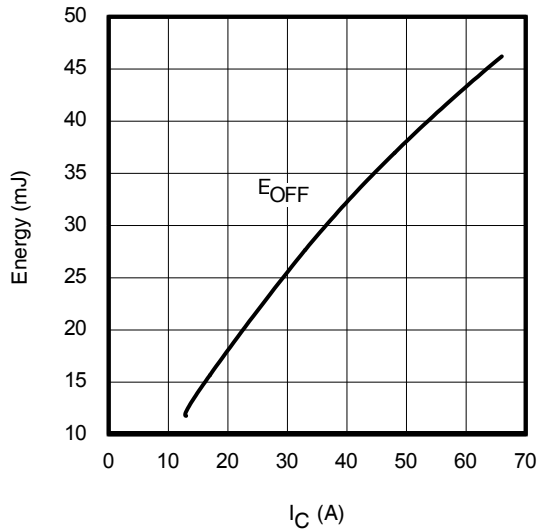
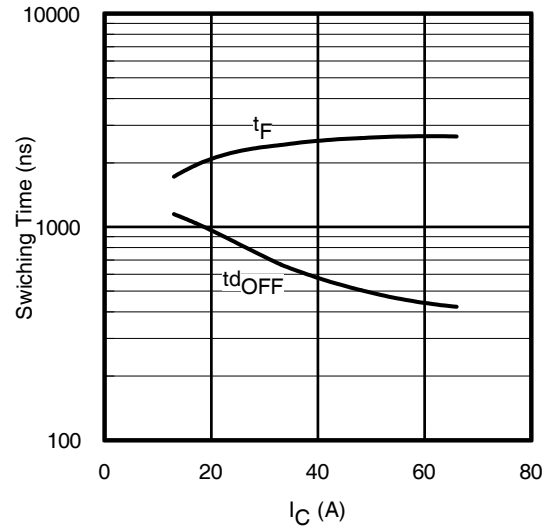
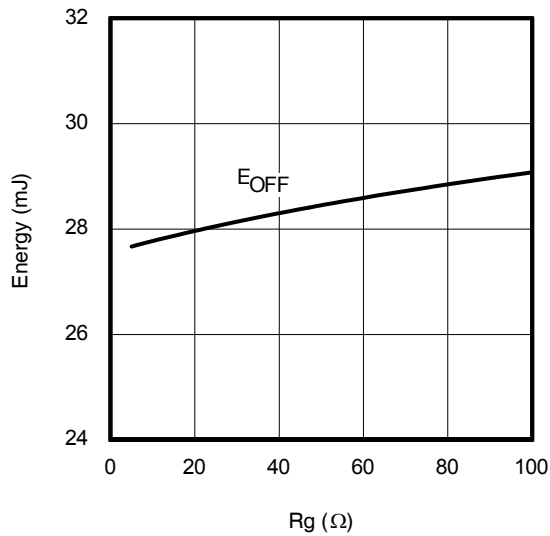
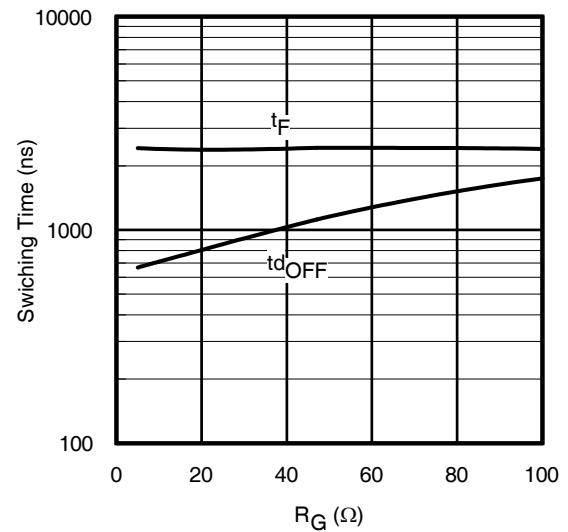
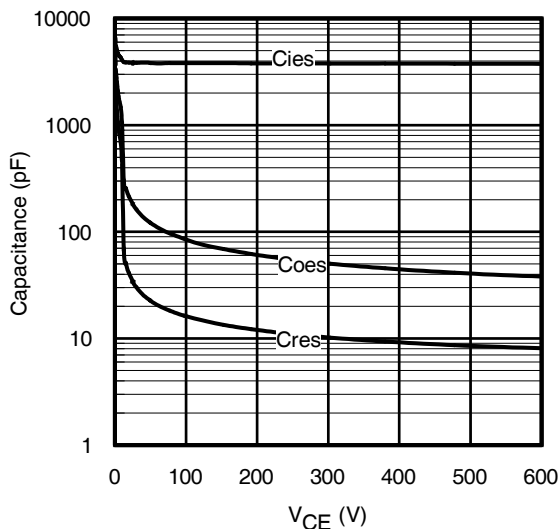
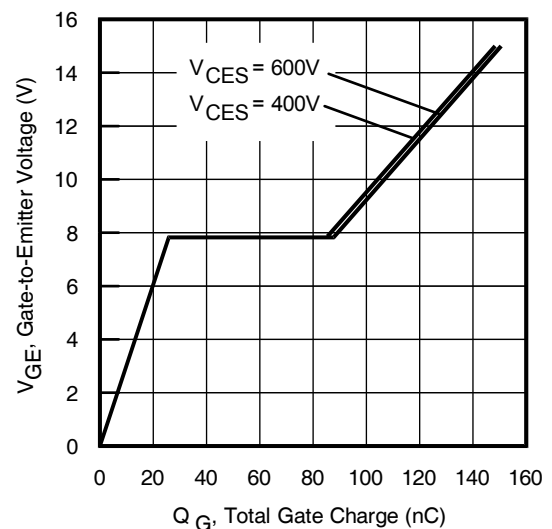

Fig. 12 - Typ. Transfer Characteristics
 $V_{CE} = 50\text{V}$; $t_p = 20\mu\text{s}$

Fig. 13 - Typ. Energy Loss vs. I_C
 $T_J = 150^\circ\text{C}; L = 400\mu\text{H}; V_{CE} = 600\text{V}, R_G = 5\Omega; V_{GE} = 15\text{V}$

Fig. 14 - Typ. Switching Time vs. I_C
 $T_J = 150^\circ\text{C}; L = 400\mu\text{H}; V_{CE} = 600\text{V}, R_G = 5\Omega; V_{GE} = 15\text{V}$

Fig. 15 - Typ. Energy Loss vs. R_G
 $T_J = 150^\circ\text{C}; L = 400\mu\text{H}; V_{CE} = 600\text{V}, I_{CE} = 33\text{A}; V_{GE} = 15\text{V}$

Fig. 16 - Typ. Switching Time vs. R_G
 $T_J = 150^\circ\text{C}; L = 400\mu\text{H}; V_{CE} = 600\text{V}, I_{CE} = 33\text{A}; V_{GE} = 15\text{V}$

Fig. 17 - Typ. Capacitance vs. V_{CE}
 $V_{GE} = 0\text{V}; f = 1\text{MHz}$

Fig. 18 - Typical Gate Charge vs. V_{GE}
 $I_{CE} = 33\text{A}; L = 2.0\text{mH}$

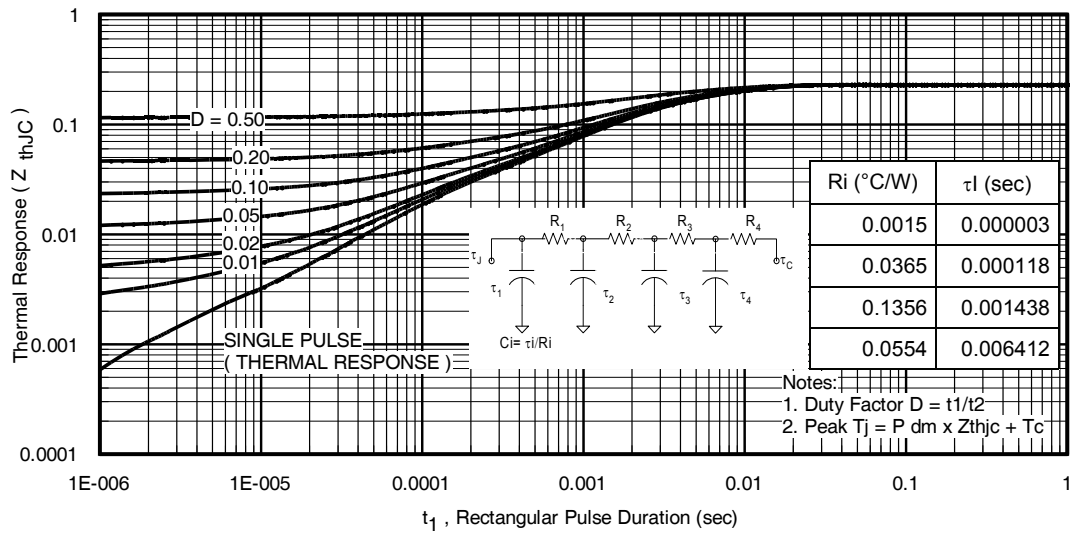
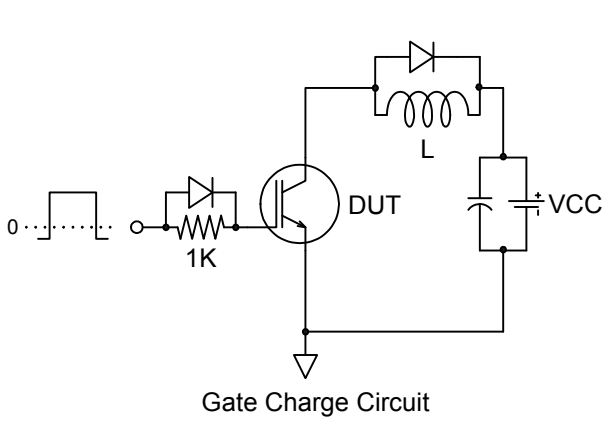
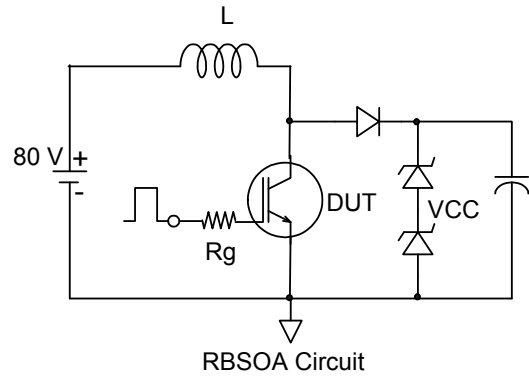
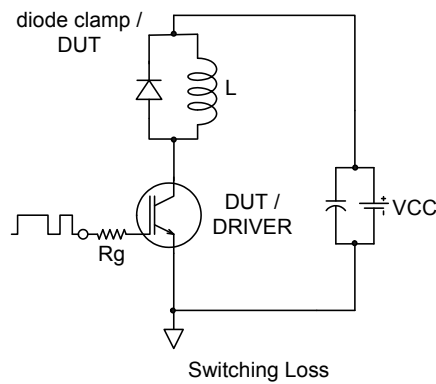
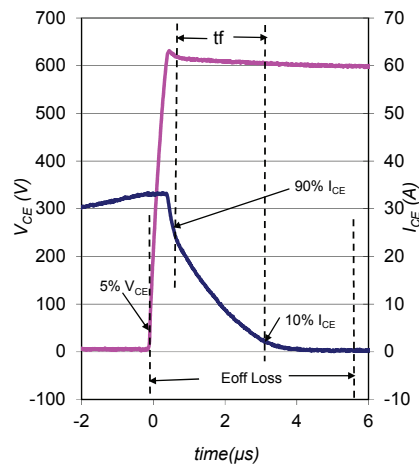
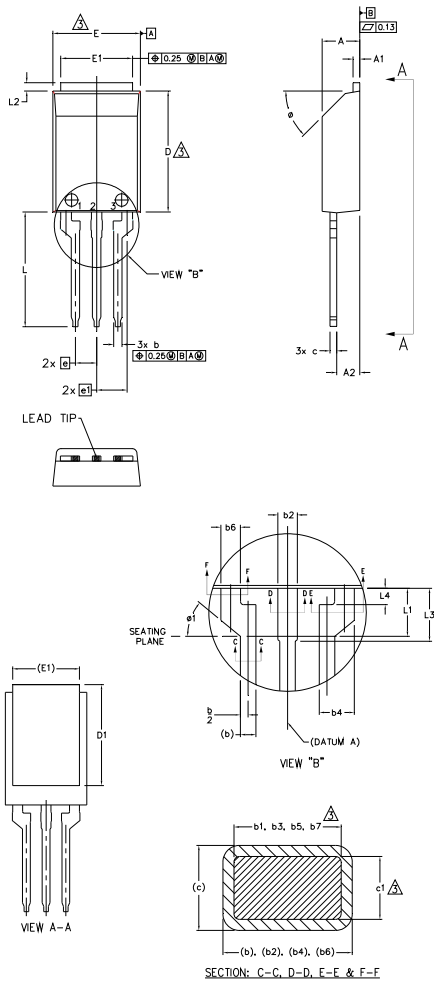

Fig 19. Maximum Transient Thermal Impedance, Junction-to-Case (IGBT)

Fig.C.T.1 - Gate Charge Circuit (turn-off)

Fig.C.T.2 - RBSOA Circuit

Fig.C.T.3 - Switching Loss Circuit

**Fig. WF1 - Typ. Turn-off Loss Waveform
@ $T_j = 150^\circ\text{C}$ using Fig. CT.3**

Super-TO-220 Package Outline

Dimensions are shown in millimeters (inches)



NOTES:

1. DIMENSIONING AND TOLERANCING AS PER ASME Y14.5M-1994
2. DIMENSIONS b1, b3, b5 & c1 APPLY TO BASE METAL ONLY.
3. DIMENSION D & E DO NOT INCLUDE MOLD FLASH. MOLD FLASH SHALL NOT EXCEED 0.127 [,.005"] PER SIDE. THESE DIMENSIONS ARE MEASURED AT THE OUTER EXTREMES OF THE PLASTIC BODY.
- 4.- ALL DIMENSIONS SHOWN IN MILLIMETERS.
- 5.- CONTROLLING DIMENSION: MILLIMETER.
- 6.- OUTLINE CONFORMS TO JEDEC OUTLINE TO-273AA.

SYMBO L	DIMENSIONS				NOTES
	MILLIMETERS		INCHES		
	MIN.	MAX.	MIN.	MAX.	
A	4.34	4.74	.171	.187	
A1	0.50	1.00	.020	.039	
A2	2.50	3.00	.098	.118	
b	0.90	1.30	.035	.051	
b1	0.80	1.10	.031	.043	2
b2	1.25	1.65	.049	.065	
b3	1.10	1.55	.043	.061	2
b4	2.35	2.55	.093	.100	
b5	2.30	2.50	.091	.098	2
b6	1.25	1.65	.049	.065	
b7	1.10	1.55	.043	.061	2
c	0.70	1.00	.028	.039	
c1	0.60	0.90	.024	.035	2
D	14.00	15.00	.0551	.591	3
D1	12.50	13.50	.492	.531	
E	10.00	11.00	.394	.433	3
E1	8.00	9.00	.315	.354	
e	2.55 BSC		.100 BSC		
e1	3.66 BSC		.144 BSC		
L	13.00	14.50	.512	.571	
L1	3.00	3.50	.118	.138	
L2	0.50	1.50	.020	.059	
L3	3.50	4.00	.138	.157	
L4	-	1.50	-	.059	
ø	42.5*	47.5*	42.5*	47.5*	
ø1	-	42.5*	-	42.5*	

LEAD ASSIGNMENTS

MOSFET

- 1.- GATE
- 2.- DRAIN
- 3.- SOURCE
- 4.- DRAIN

IGBT

- 1.- GATE
- 2.- COLLECTOR
- 3.- EMITTER
- 4.- COLLECTOR

Super-TO-220 Part Marking Information

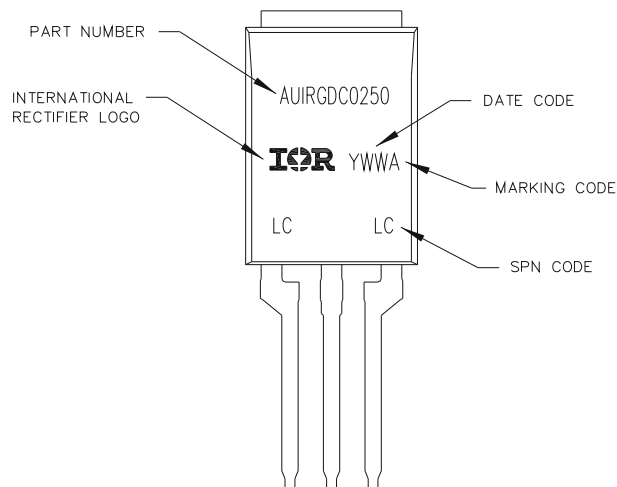

Qualification Information

Qualification Level		Automotive (per AEC-Q101)	
		Comments: This part number (s) passed Automotive qualification. Infineon's Industrial and Consumer qualification level is granted by extension of the higher Automotive level.	
Moisture Sensitivity Level		3L– Super TO-220	MSL1
ESD	Machine Model	Class M4 [†] (+/- 800V) AEC-Q101-002	
	Human Body Model	Class H3A [†] (+/- 6000V) AEC-Q101-001	
	Charged Device Model	Class C5 [†] (+/- 2000V) AEC-Q101-005	
RoHS Compliant		Yes	

† Highest passing voltage.

Revision History

Revision	Date	Subjects (major changes since last revision)
2.0	9/2/2014	• Final Datasheet
2.1	12/1/2014	• Updated with $V_{(BR)CES}$ and $V_{GE(th)}$ conditions
2.2	3/2/2015	• Updated with minor changes
2.3	8/31/2017	• Updated with Infineon logo
2.4	03/01/2018	• Updated with qualification level
2.5	11/06/2018	• Updated maximum $V_{CE(on)}$
2.6	4/18/2019	• Updated typical $V_{ce(on)}$ value @ 150°C

**Published by
Infineon Technologies AG
81726 München, Germany
© Infineon Technologies AG 2018
All Rights Reserved.**

IMPORTANT NOTICE

The information given in this document shall in no event be regarded as a guarantee of conditions or characteristics ("Beschaffenhheitsgarantie"). With respect to any examples, hints or any typical values stated herein and/or any information regarding the application of the product, Infineon Technologies hereby disclaims any and all warranties and liabilities of any kind, including without limitation warranties of non-infringement of intellectual property rights of any third party.

In addition, any information given in this document is subject to customer's compliance with its obligations stated in this document and any applicable legal requirements, norms and standards concerning customer's products and any use of the product of Infineon Technologies in customer's applications.

The data contained in this document is exclusively intended for technically trained staff. It is the responsibility of customer's technical departments to evaluate the suitability of the product for the intended application and the completeness of the product information given in this document with respect to such application.

For further information on the product, technology, delivery terms and conditions and prices please contact your nearest Infineon Technologies office (www.infineon.com).

WARNINGS

Due to technical requirements products may contain dangerous substances. For information on the types in question please contact your nearest Infineon Technologies office.

Except as otherwise explicitly approved by Infineon Technologies in a written document signed by authorized representatives of Infineon Technologies, Infineon Technologies' products may not be used in any applications where a failure of the product or any consequences of the use thereof can reasonably be expected to result in personal injury.

Looking for pricing, stock, or lifecycle information?

Click below to explore more details on WIN SOURCE:

 [View AUIRGDC0250 on WIN SOURCE](#)

 [Infineon Technologies](#) Information

Optimize Your Supply Chain with WIN SOURCE Solutions

-  Global Sourcing Solution
-  Obsolete Management
-  Cost Control Management
-  Shortage Management
-  Alternative Solution
-  Excess Inventory Management