



# THE DATASHEET OF OPA2111KP





OPA2111

## Dual Low Noise Precision *Difet*<sup>®</sup> OPERATIONAL AMPLIFIER

### FEATURES

- **LOW NOISE:** 100% Tested,  $8\text{nV}/\sqrt{\text{Hz}}$  max at 10kHz
- **LOW BIAS CURRENT:** 4pA max
- **LOW OFFSET:** 500 $\mu\text{V}$  max
- **LOW DRIFT:** 2.8 $\mu\text{V}/^\circ\text{C}$
- **HIGH OPEN-LOOP GAIN:** 114dB min
- **HIGH COMMON-MODE REJECTION:** 96dB min

### APPLICATIONS

- **PRECISION INSTRUMENTATION**
- **DATA ACQUISITION**
- **TEST EQUIPMENT**
- **PROFESSIONAL AUDIO EQUIPMENT**
- **MEDICAL EQUIPMENT**
- **DETECTOR ARRAYS**

### DESCRIPTION

The OPA2111 is a high precision monolithic dielectrically isolated FET (*Difet*) operational amplifier. Outstanding performance characteristics allow its use in the most critical instrumentation applications.

Noise, bias current, voltage offset, drift, open-loop gain, common-mode rejection, and power supply rejection are superior to BIFET<sup>®</sup> amplifiers.

Very low bias current is obtained by dielectric isolation with on-chip guarding.

Laser trimming of thin-film resistors gives very low offset and drift. Extremely low noise is achieved with patented circuit design techniques. A cascode design allows high precision input specifications and reduced susceptibility to flicker noise.

Standard dual op amp pin configuration allows upgrading of existing designs to higher performance levels.

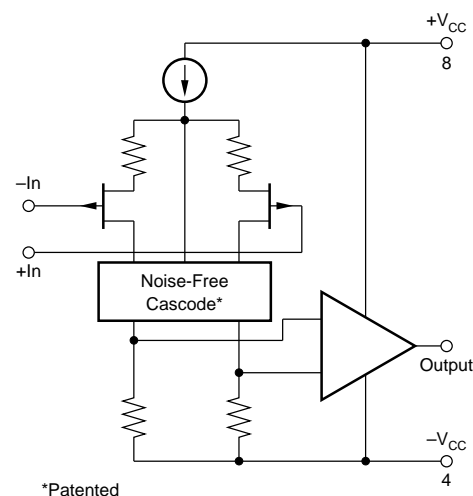

OPA2111 Simplified Circuit  
(Each Amplifier)

BIFET<sup>®</sup> National Semiconductor Corp., *Difet*<sup>®</sup> Burr-Brown Corp.

International Airport Industrial Park • Mailing Address: PO Box 11400 • Tucson, AZ 85734 • Street Address: 6730 S. Tucson Blvd. • Tucson, AZ 85706  
Tel: (520) 746-1111 • Twx: 910-952-1111 • Cable: BBRCORP • Telex: 066-6491 • FAX: (520) 889-1510 • Immediate Product Info: (800) 548-6132

# SPECIFICATIONS

## ELECTRICAL

At  $V_{CC} = \pm 15\text{VDC}$  and  $T_A = +25^\circ\text{C}$  unless otherwise noted

PARAMETER	CONDITION	OPA2111AM			OPA2111BM			OPA2111SM			OPA2111KM, KP			UNITS	
		MIN	TYP	MAX	MIN	TYP	MAX	MIN	TYP	MAX	MIN	TYP	MAX		
<b>INPUT NOISE</b> Voltage, $f_o = 10\text{Hz}$ $f_o = 100\text{Hz}$ $f_o = 1\text{kHz}$ $f_o = 10\text{kHz}$ $f_B = 10\text{Hz}$ to $10\text{kHz}$ $f_B = 0.1\text{Hz}$ to $10\text{Hz}$ Current, $f_B = 0.1\text{Hz}$ to $10\text{Hz}$ $f_o = 0.1\text{Hz}$ to $20\text{kHz}$	100% Tested		40	80		30	60		40	80		40		$\text{nV}/\sqrt{\text{Hz}}$	
	100% Tested		15	40		11	30		15	40		15		$\text{nV}/\sqrt{\text{Hz}}$	
	100% Tested		8	15		7	12		8	15		8		$\text{nV}/\sqrt{\text{Hz}}$	
	(1)		6	8		6	8		6	8		6		$\text{nV}/\sqrt{\text{Hz}}$	
	(1)		0.7	1.2		0.6	1		0.7	1.2		0.7		$\mu\text{Vrms}$	
	(1)		1.6	3.3		1.2	2.5		1.6	3.3		1.6		$\mu\text{Vp-p}$	
	(1)		15	24		12	19		15	24		15		$\text{fA p-p}$	
	(1)		0.8	1.3		0.6	1		0.8	1		0.8		$\text{fA}/\sqrt{\text{Hz}}$	
<b>OFFSET VOLTAGE</b> (2) Input Offset Voltage Average Drift Match Supply Rejection Channel Separation	$V_{CM} = 0\text{VDC}$ $T_A = T_{MIN}$ to $T_{MAX}$		$\pm 0.1$	$\pm 0.75$		$\pm 0.05$	$\pm 0.5$		$\pm 0.1$	$\pm 0.75$		$\pm 0.3$	$\pm 2$	mV	
			$\pm 2$	$\pm 6$		$\pm 0.5$	$\pm 2.8$		$\pm 2$	$\pm 6$		$\pm 8$	$\pm 15$	$\mu\text{V}/^\circ\text{C}$	
		90	$\pm 1$		96	$\pm 0.5$		90	2		86	2		$\mu\text{V}/^\circ\text{C}$	
			110		110	110		110	110		110	110		dB	
	100Hz, $R_L = 2\text{k}\Omega$		$\pm 3$	$\pm 31$		$\pm 3$	$\pm 16$		$\pm 3$	$\pm 31$		$\pm 3$	$\pm 50$	$\mu\text{V/V}$	
		136			136			136			136		dB		
<b>BIAS CURRENT</b> (2) Input Bias Current Match	$V_{CM} = 0\text{VDC}$		$\pm 2$	$\pm 8$		$\pm 1.2$	$\pm 4$		$\pm 2$	$\pm 8$		$\pm 3$	$\pm 15$	pA	
			$\pm 1$			$\pm 0.5$			$\pm 1$			2		pA	
<b>OFFSET CURRENT</b> (2) Input Offset Current	$V_{CM} = 0\text{VDC}$		$\pm 1.2$	$\pm 6$		$\pm 0.6$	$\pm 3$		$\pm 1.2$	$\pm 6$		$\pm 3$	$\pm 12$	pA	
<b>IMPEDANCE</b> Differential Common-Mode			$10^{13} \parallel 1$		$10^{13} \parallel 1$		$10^{13} \parallel 1$		$10^{13} \parallel 1$		$10^{13} \parallel 1$		$10^{13} \parallel 1$	$\Omega \parallel \text{pF}$	
			$10^{14} \parallel 3$		$10^{14} \parallel 3$		$10^{14} \parallel 3$		$10^{14} \parallel 3$		$10^{14} \parallel 3$		$10^{14} \parallel 3$	$\Omega \parallel \text{pF}$	
<b>VOLTAGE RANGE</b> Common-Mode Input Range Common-Mode Rejection	$V_{IN} = \pm 10\text{VDC}$	$\pm 10$	$\pm 11$		$\pm 10$	$\pm 11$		$\pm 10$	$\pm 11$		$\pm 10$	$\pm 11$		V	
		90	110		96	110		90	110		82	110		dB	
<b>OPEN-LOOP GAIN, DC</b> Open-Loop Voltage Gain Match	$R_L \geq 2\text{k}\Omega$	110	125		114	125		110	125		106	125		dB	
			3			2			3			3		dB	
<b>FREQUENCY RESPONSE</b> Unity Gain, Small Signal Full Power Response Slew Rate Settling Time, 0.1% 0.01% Overload Recovery, 50% Overdrive(3)	20Vp-p, $R_L = 2\text{k}\Omega$ $V_O = \pm 10\text{V}$ , $R_L = 2\text{k}\Omega$ Gain = -1, $R_L = 2\text{k}\Omega$ 10V Step Gain = -1		2		2		2		2		2		2	MHz	
		16	32		16	32		16	32		32		32	kHz	
		1	2		1	2		1	2		2		2	V/ $\mu\text{s}$	
			6			6			6		6		6	$\mu\text{s}$	
			10			10			10		10		10	$\mu\text{s}$	
			5			5			5		5		5	$\mu\text{s}$	
<b>RATED OUTPUT</b> Voltage Output Current Output Output Resistance Load Capacitance Stability Short Circuit Current	$R_L = 2\text{k}\Omega$ $V_O = \pm 10\text{VDC}$ DC, Open-Loop Gain = +1	$\pm 10$	$\pm 11$		$\pm 10$	$\pm 11$		$\pm 10$	$\pm 11$		$\pm 10$	$\pm 11$		V	
		$\pm 5$	$\pm 10$		$\pm 5$	$\pm 10$		$\pm 5$	$\pm 10$		$\pm 5$	$\pm 10$		mA	
			100			100			100			100		$\Omega$	
			1000			1000			1000			1000		pF	
		10	40		10	40		10	40		10	40		mA	
<b>POWER SUPPLY</b> Rated Voltage Voltage Range, Derated Performance Current, Quiescent	$I_O = 0\text{mADC}$		$\pm 15$		$\pm 15$		$\pm 15$		$\pm 15$		$\pm 15$		$\pm 15$	VDC	
		$\pm 5$		$\pm 18$	$\pm 5$		$\pm 18$	$\pm 5$		$\pm 18$	$\pm 5$		$\pm 18$	VDC	
			5	7		5	7		5	7		5	9	mA	
<b>TEMPERATURE RANGE</b> Specification Operating "M" Package "P" Package Storage "M" Package "P" Package $\theta$ Junction-Ambient	Ambient Temp.	-25		+85	-25		+85	-55		+125	0		+70	$^\circ\text{C}$	
		-55		+125	-55		+125	-55		+125	-55		+125	$^\circ\text{C}$	
												-40		+85	$^\circ\text{C}$
		-65		+150	-65		+150	-65		+150	-65		+150	$^\circ\text{C}$	
												-40		+85	$^\circ\text{C}$
		200				200			200			200(4)			$^\circ\text{C/W}$

NOTES: (1) Sample tested—this parameter is guaranteed. (2) Offset voltage, offset current, and bias current are measured with the units fully warmed up. (3) Overload recovery is defined as the time required for the output to return from saturation to linear operation following the removal of a 50% input overdrive. (4) Typical  $\theta_{JA} = 150^\circ\text{C/W}$  for plastic DIP.

## ELECTRICAL (FULL TEMPERATURE RANGE SPECIFICATIONS)

At  $V_{CC} = \pm 15\text{VDC}$  and  $T_A = T_{MIN}$  to  $T_{MAX}$  unless otherwise noted.

PARAMETER	CONDITION	OPA2111AM			OPA2111BM			OPA2111SM			OPA2111KM, KP			UNITS
		MIN	TYP	MAX	MIN	TYP	MAX	MIN	TYP	MAX	MIN	TYP	MAX	
<b>TEMPERATURE RANGE</b> Specification Range	Ambient Temp.	-25		+85	-25		+85	-55		+125	0		+70	°C
<b>INPUT OFFSET VOLTAGE<sup>(1)</sup></b> Input Offset Voltage Average Drift Match Supply Rejection	$V_{CM} = 0\text{VDC}$		$\pm 0.22$ $\pm 2$ 1 86	$\pm 1.2$ $\pm 6$ 1 $\pm 10$		$\pm 0.08$ $\pm 0.5$ 0.5 90	$\pm 0.75$ $\pm 2.8$ 0.5 $\pm 10$		$\pm 0.3$ $\pm 2$ 2 86	$\pm 1.5$ $\pm 6$ 2 $\pm 10$		$\pm 0.9$ $\pm 8$ 2 82	$\pm 5$ $\pm 15$ 2 $\pm 10$	mV $\mu\text{V}/^\circ\text{C}$ $\mu\text{V}/^\circ\text{C}$ dB $\mu\text{V}/\text{V}$
<b>BIAS CURRENT<sup>(1)</sup></b> Input Bias Current Match	$V_{CM} = 0\text{VDC}$		$\pm 125$ 60	$\pm 1\text{nA}$		$\pm 75$ 30	$\pm 500$		$\pm 2\text{nA}$ 1nA	$\pm 16.3\text{nA}$		$\pm 125$ $\pm 500$	pA pA	
<b>OFFSET CURRENT<sup>(1)</sup></b> Input Offset Current	$V_{CM} = 0\text{VDC}$		$\pm 75$	$\pm 750$		$\pm 38$	$\pm 375$		$\pm 1.3\text{nA}$	$\pm 12\text{nA}$		$\pm 75$ $\pm 375$	pA	
<b>VOLTAGE RANGE</b> Common-Mode Input Range Common-Mode Rejection	$V_{IN} = \pm 10\text{VDC}$	$\pm 10$ 86	$\pm 11$ 100		$\pm 10$ 90	$\pm 11$ 100		$\pm 10$ 86	$\pm 11$ 100		$\pm 10$ 80	$\pm 11$ 100	V dB	
<b>OPEN-LOOP GAIN, DC</b> Open-Loop Voltage Gain Match	$R_L \geq 2\text{k}\Omega$	106	120 5		110	120 3		106	120 5		100	120 5	dB dB	
<b>RATED OUTPUT</b> Voltage Output Current Output Short Circuit Current	$R_L = 2\text{k}\Omega$ $V_O = \pm 10\text{VDC}$ $V_O = 0\text{VDC}$	$\pm 10.5$ $\pm 5$ 10	$\pm 11$ $\pm 10$ 40		$\pm 10.5$ $\pm 5$ 10	$\pm 11$ $\pm 10$ 40		$\pm 10.5$ $\pm 5$ 10	$\pm 11$ $\pm 10$ 40		$\pm 10.5$ $\pm 5$ 10	$\pm 11$ $\pm 10$ 40	V mA mA	
<b>POWER SUPPLY</b> Current, Quiescent	$I_O = 0\text{mADC}$		5 8		5 8	5 8		5 8	5 8		5 10	10	mA	

NOTES: (1) Offset voltage, offset current, and bias current are measured with the units fully warmed up.

## CONNECTION DIAGRAMS

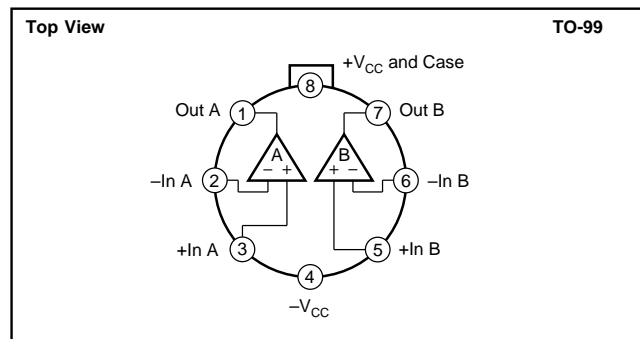
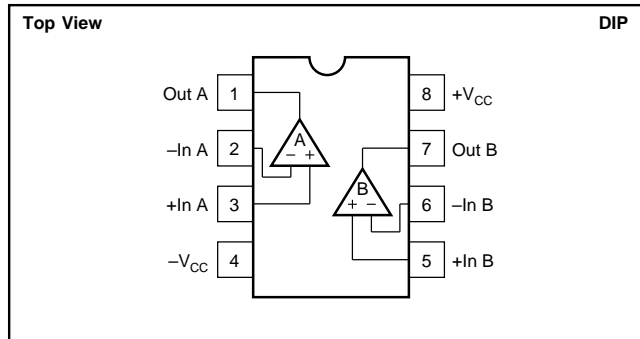

## ABSOLUTE MAXIMUM RATINGS

Supply	$\pm 18\text{VDC}$
Internal Power Dissipation ( $T_J \leq +175^\circ\text{C}$ )	500mW
Differential Input Voltage	Total $V_{CC}$
Input Voltage Range	$\pm V_{CC}$
Storage Temperature Range: "M" Package	$-65^\circ\text{C}$ to $+150^\circ\text{C}$
"P" Package	$-40^\circ\text{C}$ to $+85^\circ\text{C}$
Operating Temperature Range: "M" Package	$-55^\circ\text{C}$ to $+125^\circ\text{C}$
"P" Package	$-40^\circ\text{C}$ to $+85^\circ\text{C}$
Lead Temperature (soldering, 10s)	$+300^\circ\text{C}$
Output Short Circuit to Ground ( $+25^\circ\text{C}$ )	Continuous
Junction Temperature	$+175^\circ\text{C}$

## PACKAGE INFORMATION

MODEL	PACKAGE	PACKAGE DRAWING NUMBER <sup>(1)</sup>
OPA2111AM	TO-99	001
OPA2111BM	TO-99	001
OPA2111KM	TO-99	001
OPA2111SM	TO-99	001
OPA2111KP	8-Pin Plastic DIP	006

NOTE: (1) For detailed drawing and dimension table, please see end of data sheet, or Appendix D of Burr-Brown IC Data Book.

## ORDERING INFORMATION

MODEL	PACKAGE	TEMPERATURE RANGE	OFFSET VOLTAGE, max (mV)
OPA2111AM	TO-99	$-25^\circ\text{C}$ to $+85^\circ\text{C}$	$\pm 0.75$
OPA2111BM	TO-99	$-25^\circ\text{C}$ to $+85^\circ\text{C}$	$\pm 0.5$
OPA2111KM	TO-99	$0^\circ\text{C}$ to $+70^\circ\text{C}$	$\pm 2$
OPA2111SM	TO-99	$-55^\circ\text{C}$ to $+125^\circ\text{C}$	$\pm 0.75$
OPA2111KP	8-Pin Plastic DIP	$0^\circ\text{C}$ to $+70^\circ\text{C}$	$\pm 2$

## DICE INFORMATION

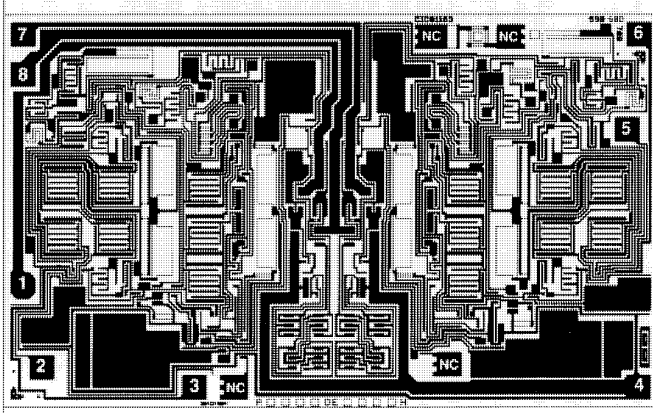

OPA2111AD DIE TOPOGRAPHY

PAD	FUNCTION
1	Out A
2	-In A
3	+In A
4	-V <sub>S</sub>
5	+In B
6	-In B
7	Out B
8	+V <sub>S</sub>
NC	No Connection

Substrate Bias: No Connection

## MECHANICAL INFORMATION

	MILS (0.001")	MILLIMETERS
Die Size	138 x 84 ±5	3.51 x 2.13 ±0.13
Die Thickness	20 ±3	0.51 ±0.08
Min. Pad Size	4 x 4	0.10 x 0.10
Backing		None
Transistor Count		102

## TYPICAL PERFORMANCE CURVES

T<sub>A</sub> = +25°C, and V<sub>CC</sub> = ±15VDC unless otherwise noted.

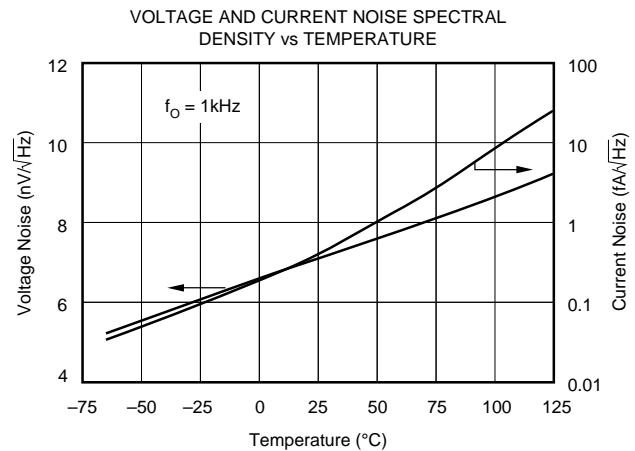
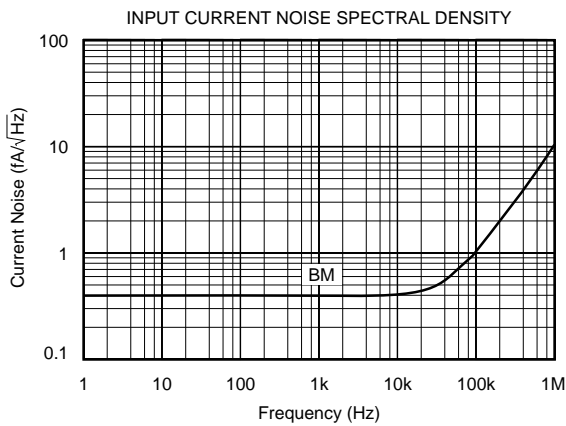

# TYPICAL PERFORMANCE CURVES (CONT)

$T_A = +25^\circ\text{C}$ , and  $V_{CC} = \pm 15\text{VDC}$  unless otherwise noted.

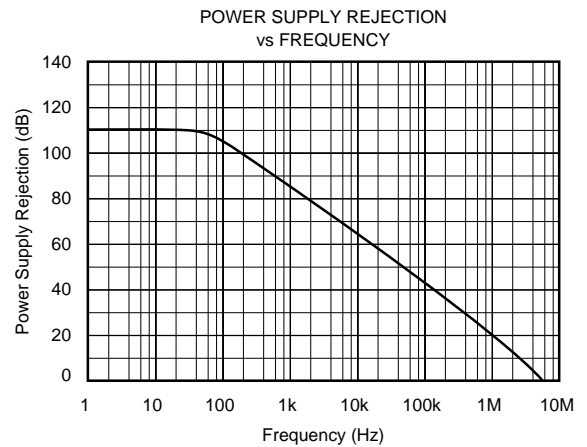
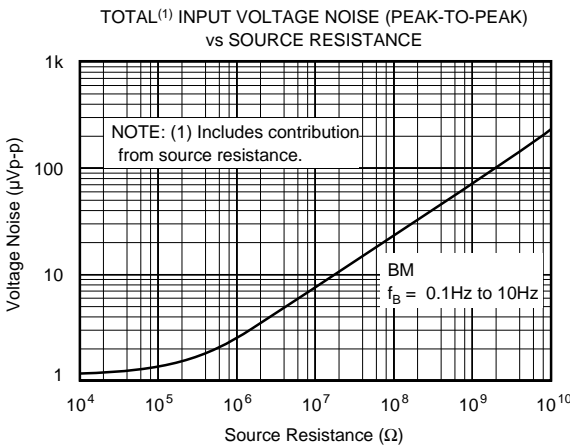
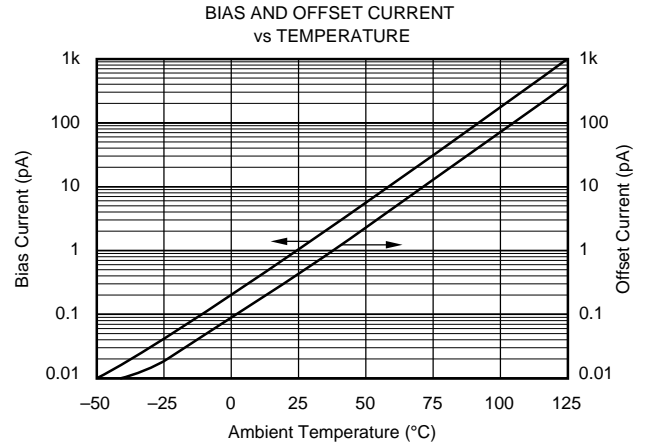
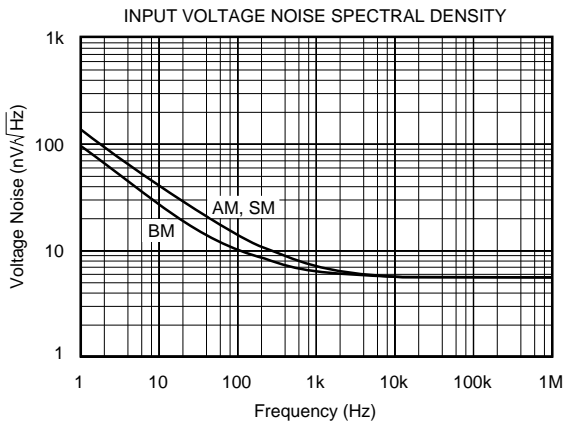
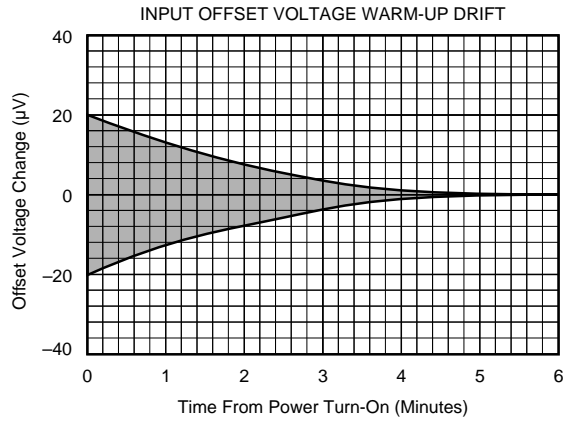
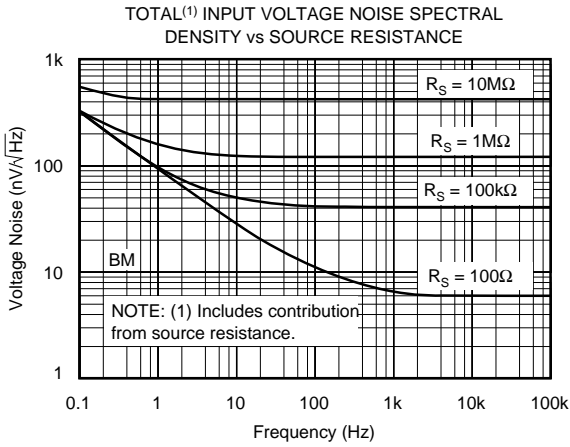

# TYPICAL PERFORMANCE CURVES (CONT)

$T_A = +25^\circ\text{C}$ , and  $V_{CC} = \pm 15\text{VDC}$  unless otherwise noted.

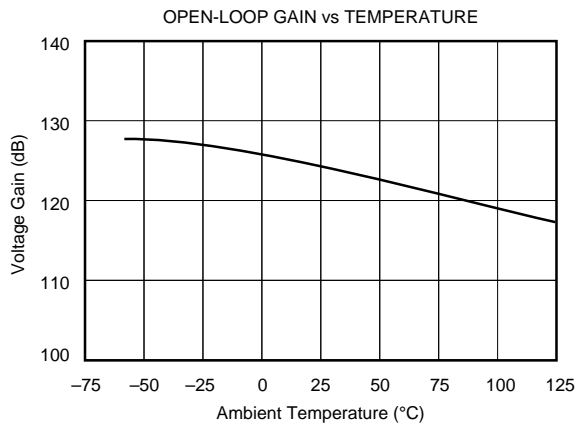
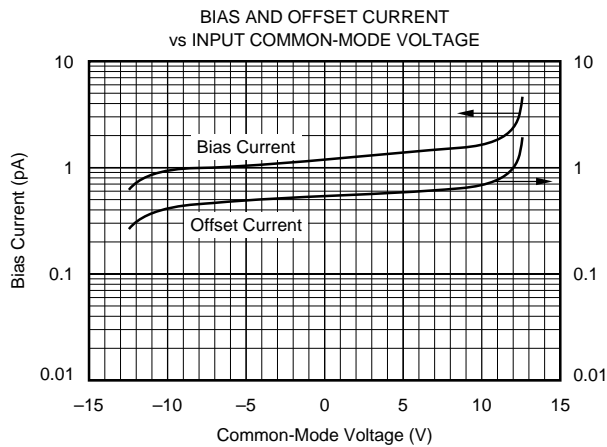
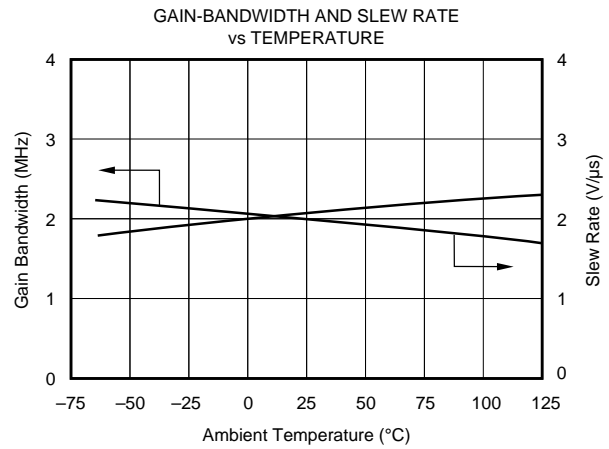
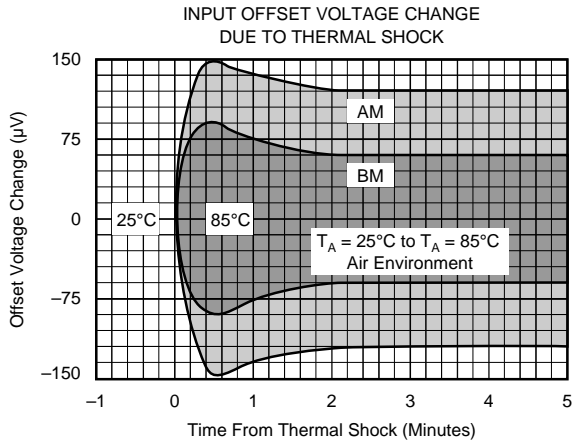
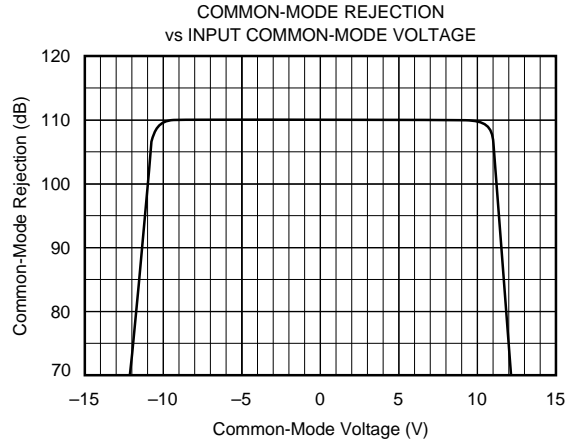
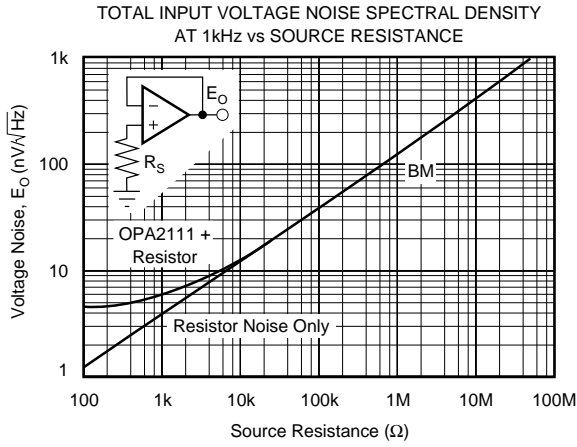

# TYPICAL PERFORMANCE CURVES (CONT)

$T_A = +25^\circ\text{C}$ ,  $V_{CC} = \pm 15\text{VDC}$  unless otherwise noted.

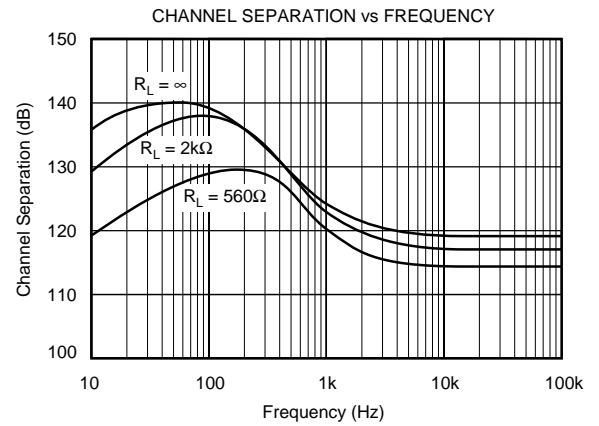
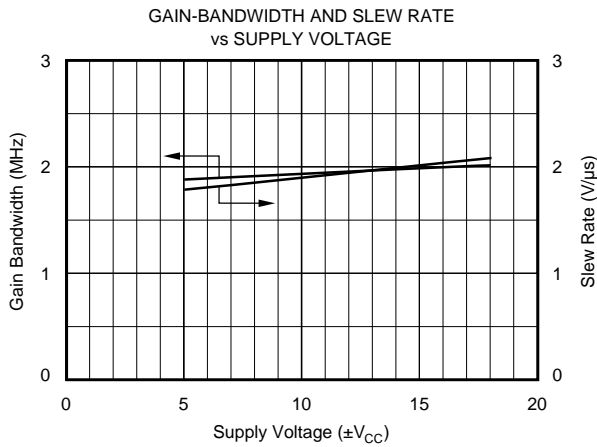
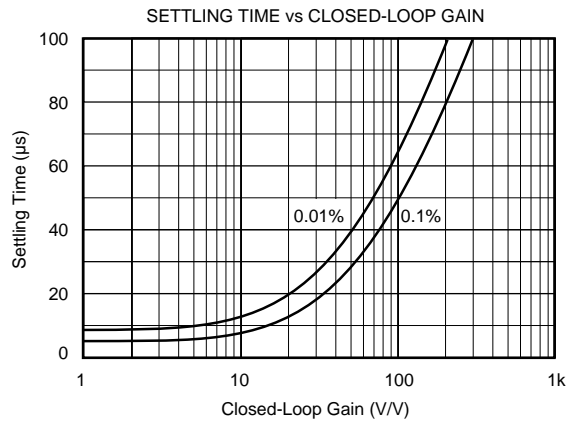
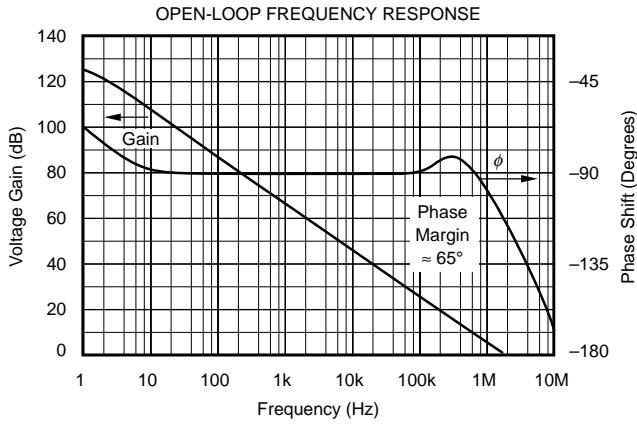
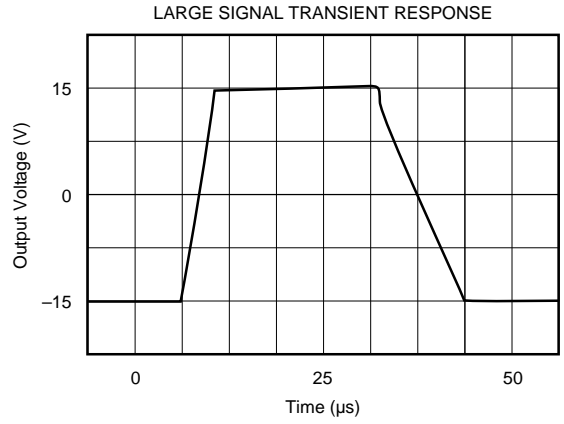
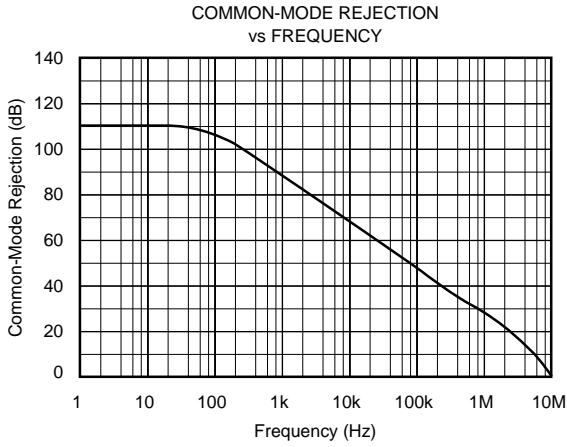

# TYPICAL PERFORMANCE CURVES (CONT)

$T_A = +25^\circ\text{C}$ ,  $V_{CC} = \pm 15\text{VDC}$  unless otherwise noted.

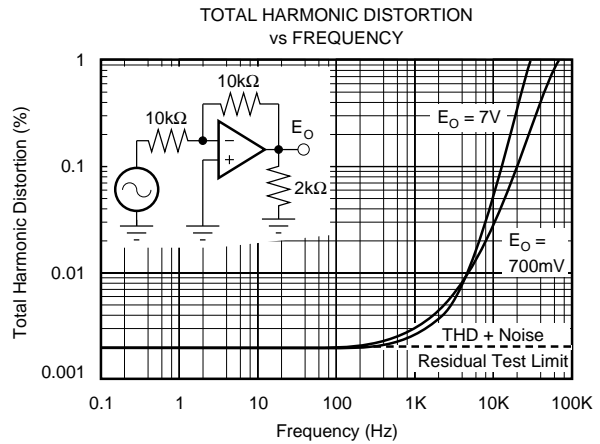
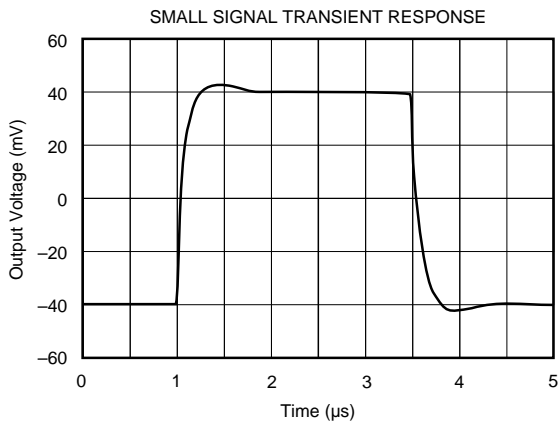
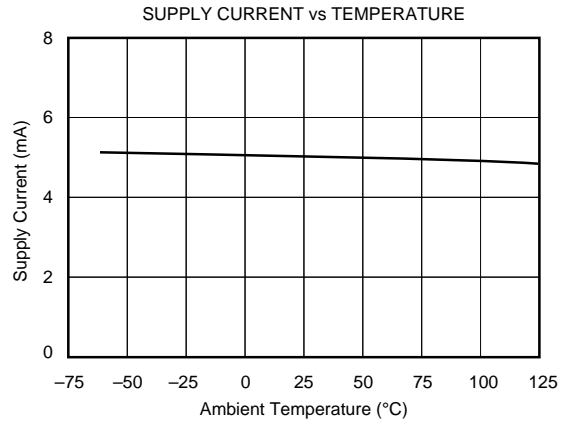
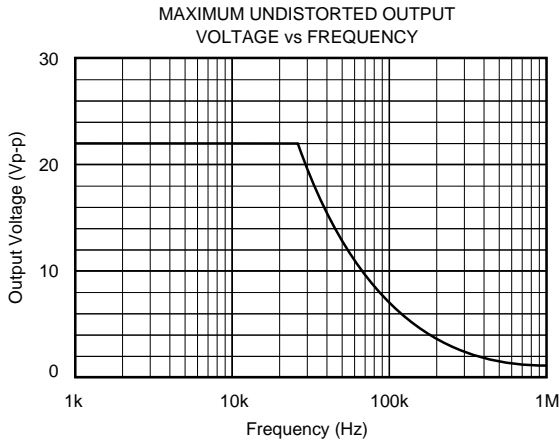

## APPLICATIONS INFORMATION

### OFFSET VOLTAGE ADJUSTMENT

The OPA2111 offset voltage is laser-trimmed and will require no further trim for most applications.

Offset voltage can be trimmed by summing (see Figure 1). With this trim method there will be no degradation of input offset drift.

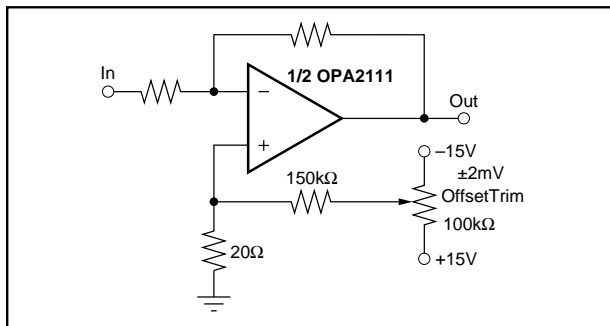

FIGURE 1. Offset Voltage Trim.

### INPUT PROTECTION

Conventional monolithic FET operational amplifiers require external current-limiting resistors to protect their inputs against destructive currents that can flow when input FET gate-to-substrate isolation diodes are forward-biased. Most BIFET amplifiers can be destroyed by the loss of  $-V_{CC}$ .

Because of its dielectric isolation, no special protection is needed on the OPA2111. Of course, the differential and common-mode voltage limits should be observed. Static damage can cause subtle changes in amplifier input characteristics without necessarily destroying the device. In precision operational amplifiers (both bipolar and FET types), this may cause a noticeable degradation of offset voltage and drift.

Static protection is recommended when handling any precision IC operational amplifier.

## GUARDING AND SHIELDING

As in any situation where high impedances are involved, careful shielding is required to reduce “hum” pickup in input leads. If large feedback resistors are used, they should also be shielded along with the external input circuitry.

Leakage currents across printed circuit boards can easily exceed the bias current of the OPA2111. To avoid leakage problems, it is recommended that the signal input lead of the OPA2111 be wired to a Teflon standoff. If the OPA2111 is to be soldered directly into a printed circuit board, utmost care must be used in planning the board layout. A “guard” pattern should completely surround the high impedance input leads and should be connected to a low impedance point which is at the signal input potential (see Figure 2).

## NOISE: FET vs BIPOLAR

Low noise circuit design requires careful analysis of all noise sources. External noise sources can dominate in many cases, so consider the effect of source resistance on overall operational amplifier noise performance. At low source impedances, the low voltage noise of a bipolar operational amplifier is superior, but at higher impedances the high current noise of a bipolar amplifier becomes a serious liability. Above about 15kΩ the OPA2111 will have lower total noise than an OP-27 (see Figure 3).

## BIAS CURRENT CHANGE vs COMMON-MODE VOLTAGE

The input bias currents of most popular BIFET® operational amplifiers are affected by common-mode voltage (Figure 4). Higher input FET gate-to-drain voltage causes leakage and ionization (bias) currents to increase. Due to its cascode input stage, the extremely low bias current of the OPA2111 is not compromised by common-mode voltage.

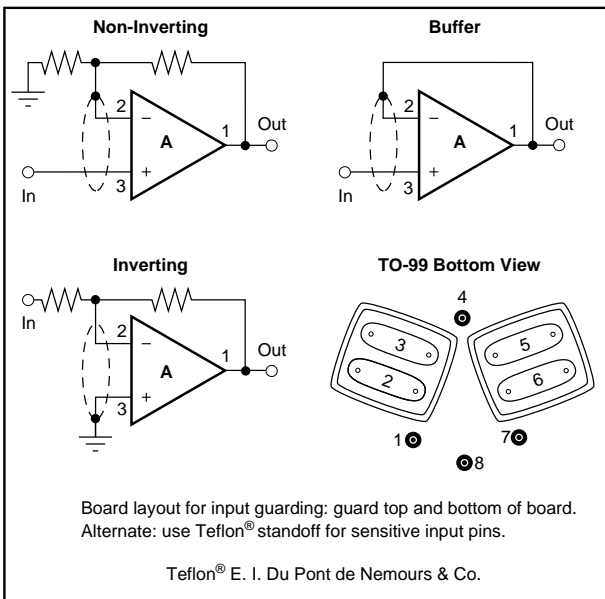

FIGURE 2. Connection of Input Guard.

## APPLICATIONS CIRCUITS

Figures 5 through 13 are circuit diagrams of various applications for the OPA2111.

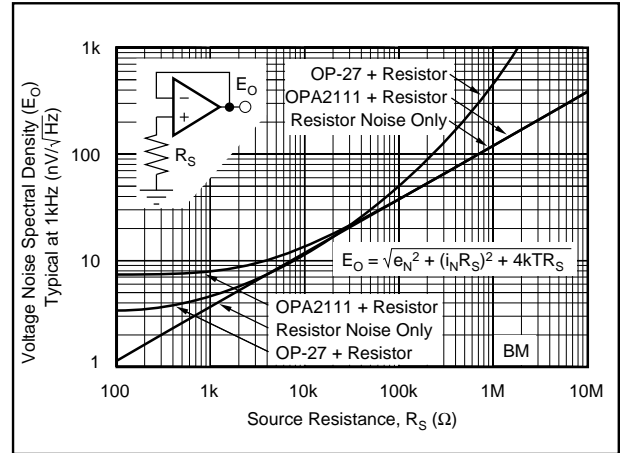

FIGURE 3. Voltage Noise Spectral Density vs Source Resistance.

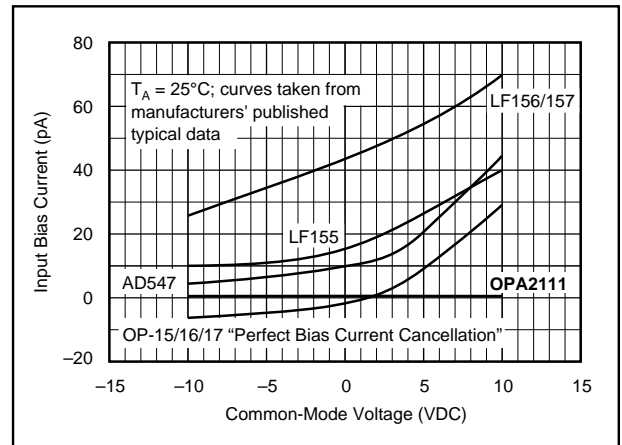

FIGURE 4. Input Bias Current vs Common-Mode Voltage.

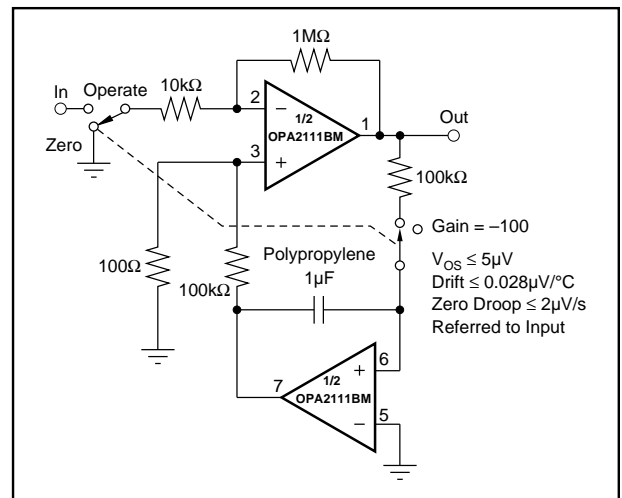

FIGURE 5. Auto-Zero Amplifier.

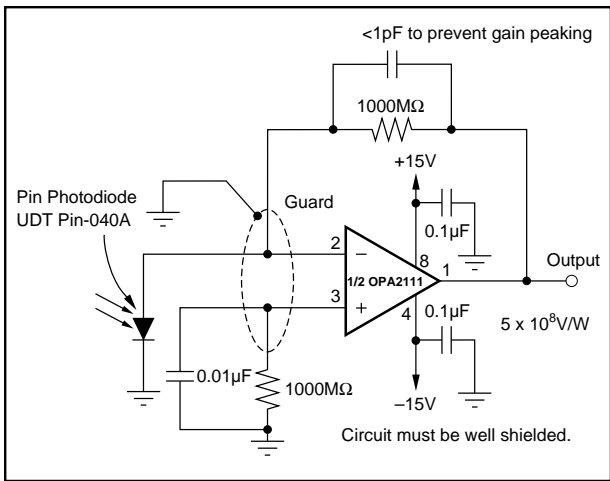

FIGURE 6. Sensitive Photodiode Amplifier.

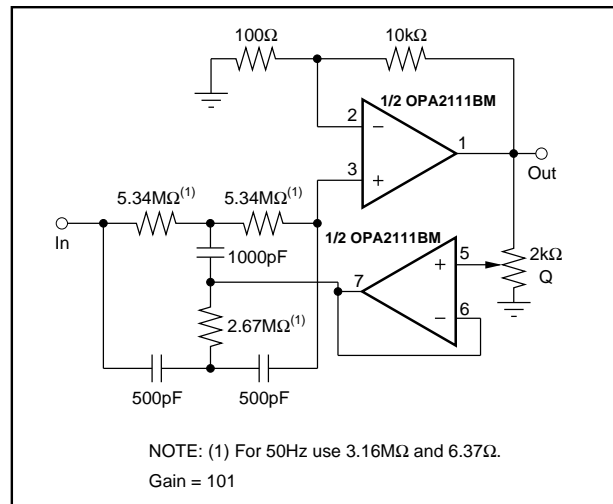

FIGURE 7. High Impedance 60Hz Reject Filter with Gain.

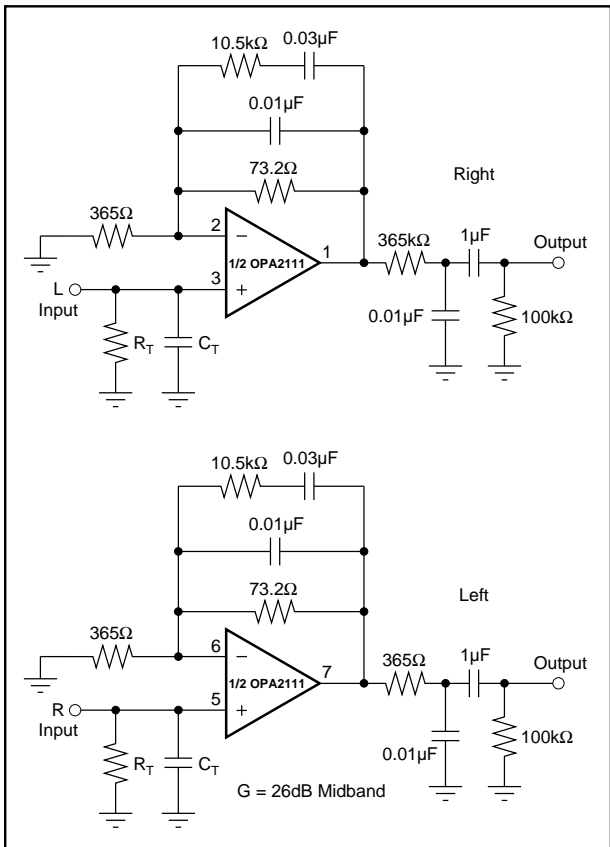

FIGURE 8. RIAA Equalized Stereo Preamplifier.

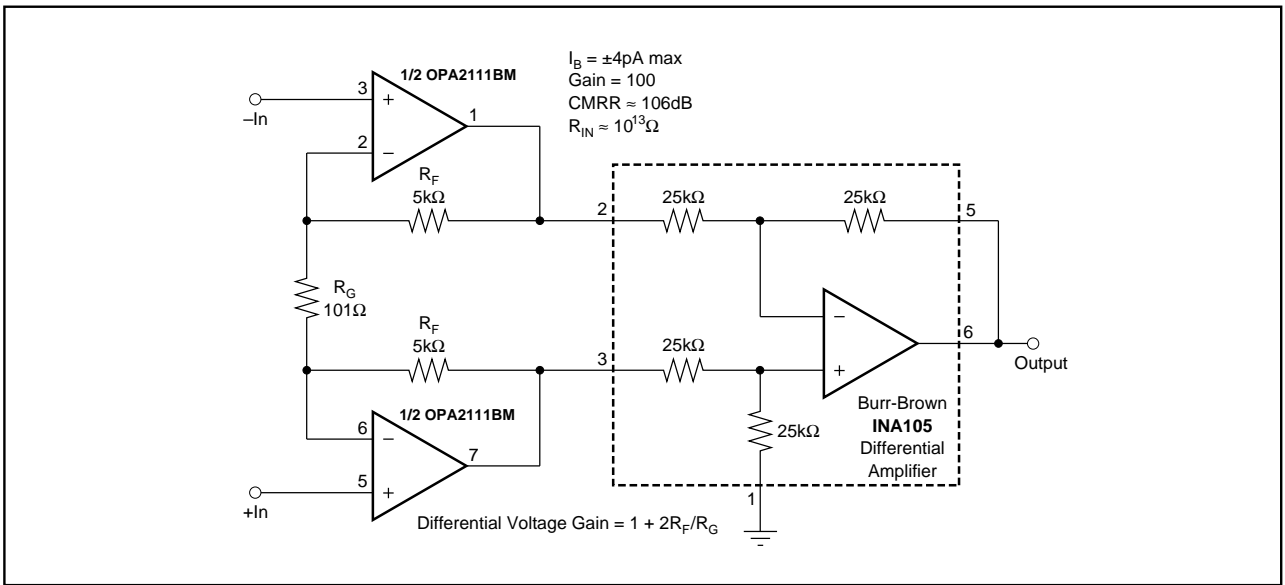

FIGURE 9. FET Input Instrumentation Amplifier.

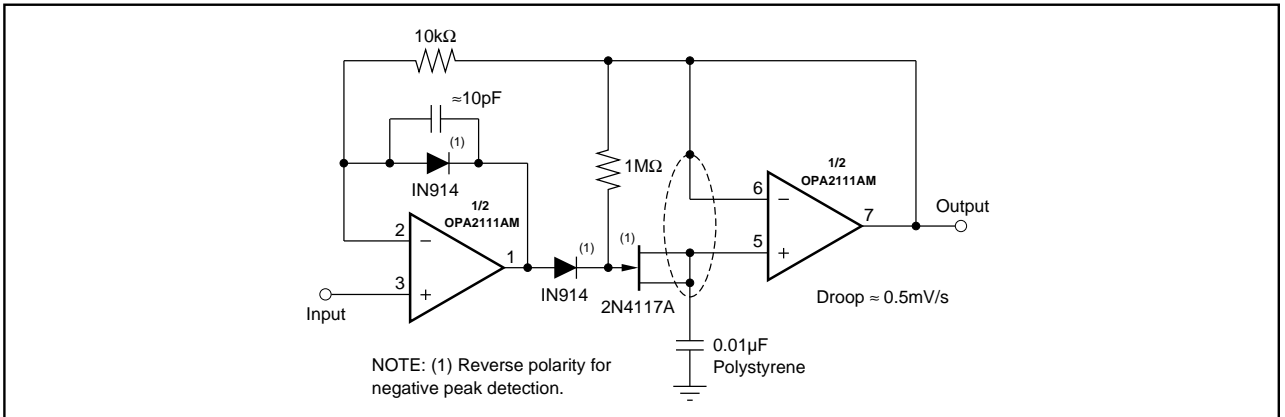

FIGURE 10. Low-Droop Positive Peak Detector.

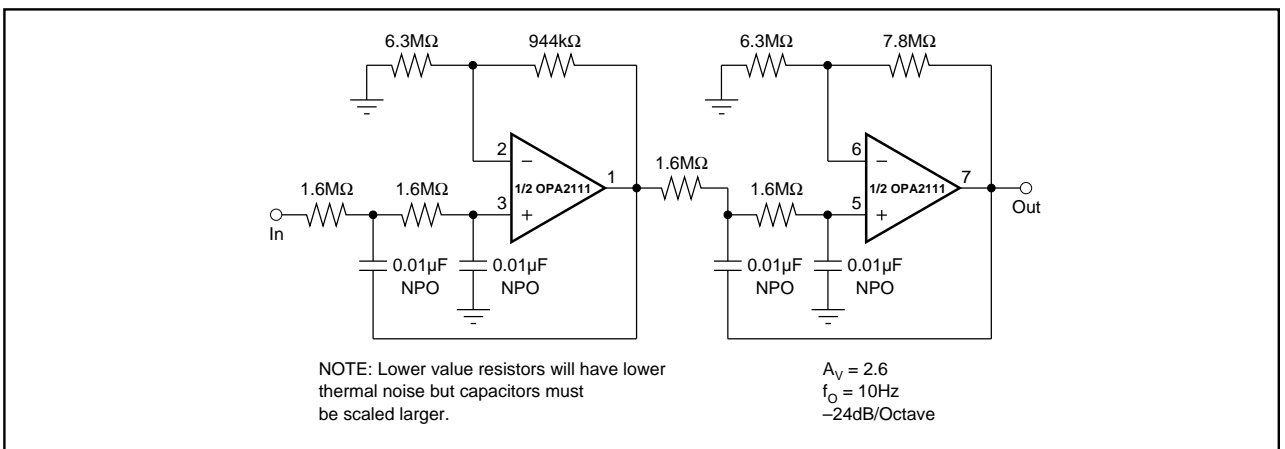

FIGURE 11. 10Hz Fourth-Order Butterworth Low-Pass Filter.

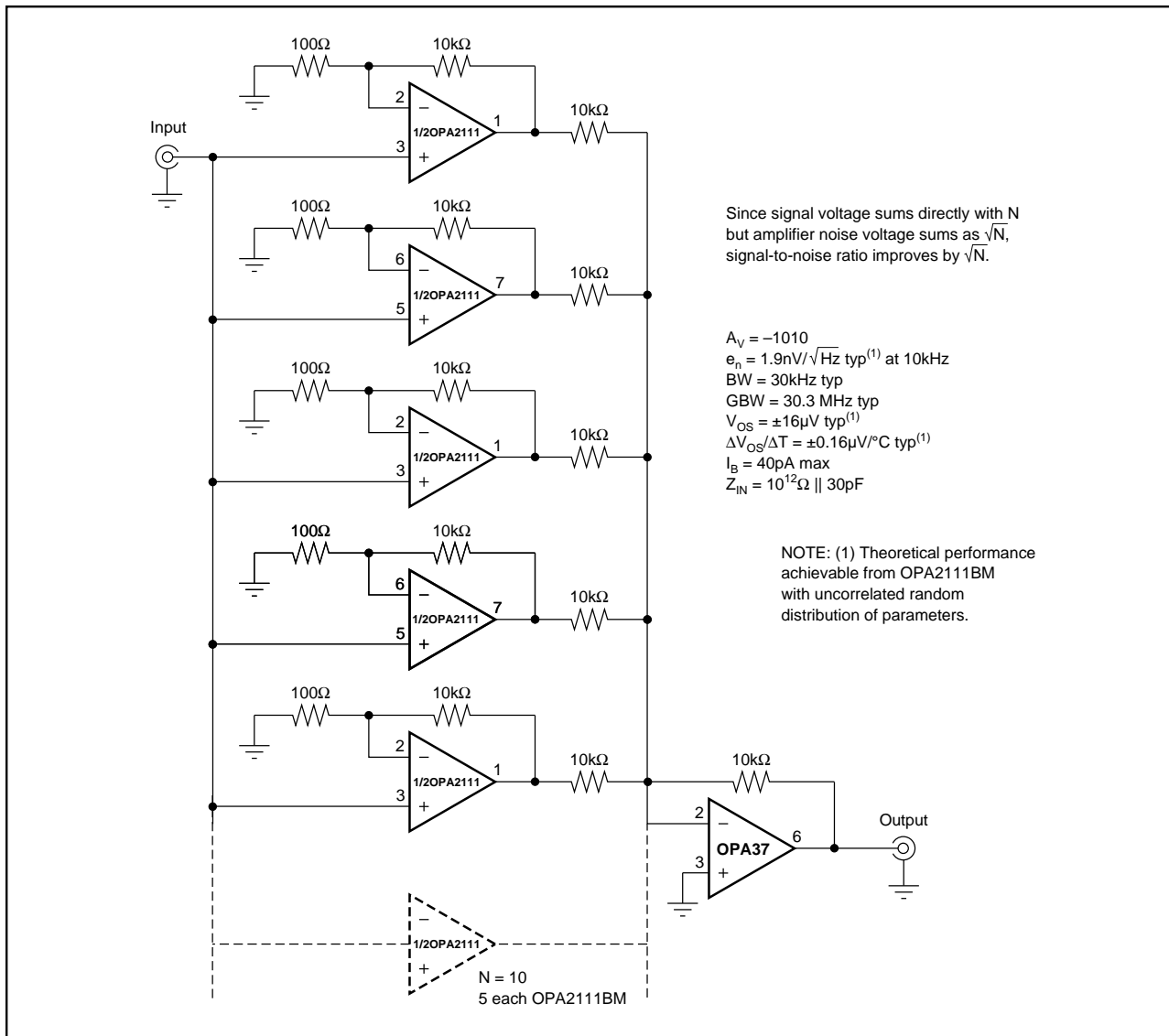

FIGURE 12. 'N' Stage Parallel-Input Amplifier.

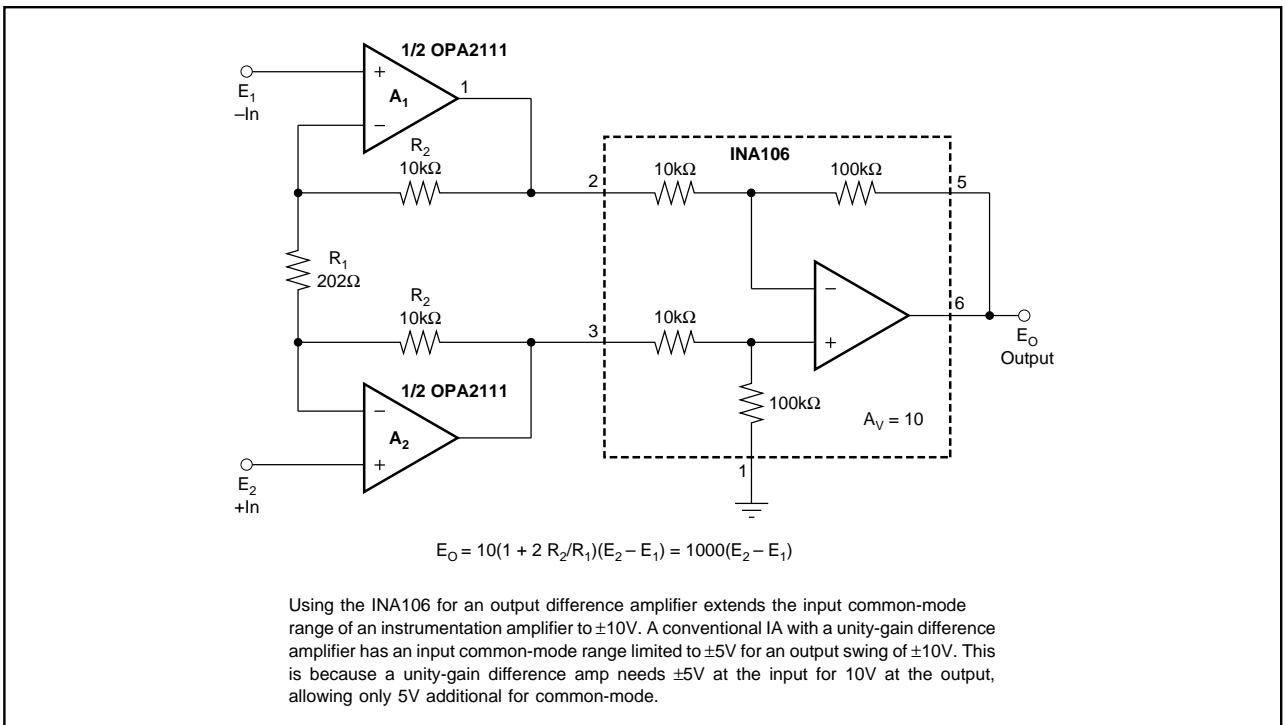

FIGURE 13. Precision Instrumentation Amplifier.

The information provided herein is believed to be reliable; however, BURR-BROWN assumes no responsibility for inaccuracies or omissions. BURR-BROWN assumes no responsibility for the use of this information, and all use of such information shall be entirely at the user's own risk. Prices and specifications are subject to change without notice. No patent rights or licenses to any of the circuits described herein are implied or granted to any third party. BURR-BROWN does not authorize or warrant any BURR-BROWN product for use in life support devices and/or systems.

**PACKAGING INFORMATION**

Orderable Device	Status <sup>(1)</sup>	Package Type	Package Drawing	Pins	Package Qty	Eco Plan <sup>(2)</sup>	Lead/Ball Finish	MSL Peak Temp <sup>(3)</sup>
OPA2111AM	NRND	TO-99	LMC	8	20	Green (RoHS & no Sb/Br)	AU	N / A for Pkg Type
OPA2111BM	NRND	TO-99	LMC	8	20	Green (RoHS & no Sb/Br)	AU	N / A for Pkg Type
OPA2111KM	NRND	TO-99	LMC	8	20	Green (RoHS & no Sb/Br)	AU	N / A for Pkg Type
OPA2111KP	ACTIVE	PDIP	P	8	50	Green (RoHS & no Sb/Br)	CU NIPDAU	N / A for Pkg Type
OPA2111KPG4	ACTIVE	PDIP	P	8	50	Green (RoHS & no Sb/Br)	CU NIPDAU	N / A for Pkg Type

<sup>(1)</sup> The marketing status values are defined as follows:

**ACTIVE:** Product device recommended for new designs.

**LIFEBUY:** TI has announced that the device will be discontinued, and a lifetime-buy period is in effect.

**NRND:** Not recommended for new designs. Device is in production to support existing customers, but TI does not recommend using this part in a new design.

**PREVIEW:** Device has been announced but is not in production. Samples may or may not be available.

**OBSOLETE:** TI has discontinued the production of the device.

<sup>(2)</sup> Eco Plan - The planned eco-friendly classification: Pb-Free (RoHS), Pb-Free (RoHS Exempt), or Green (RoHS & no Sb/Br) - please check <http://www.ti.com/productcontent> for the latest availability information and additional product content details.

**TBD:** The Pb-Free/Green conversion plan has not been defined.

**Pb-Free (RoHS):** TI's terms "Lead-Free" or "Pb-Free" mean semiconductor products that are compatible with the current RoHS requirements for all 6 substances, including the requirement that lead not exceed 0.1% by weight in homogeneous materials. Where designed to be soldered at high temperatures, TI Pb-Free products are suitable for use in specified lead-free processes.

**Pb-Free (RoHS Exempt):** This component has a RoHS exemption for either 1) lead-based flip-chip solder bumps used between the die and package, or 2) lead-based die adhesive used between the die and leadframe. The component is otherwise considered Pb-Free (RoHS compatible) as defined above.

**Green (RoHS & no Sb/Br):** TI defines "Green" to mean Pb-Free (RoHS compatible), and free of Bromine (Br) and Antimony (Sb) based flame retardants (Br or Sb do not exceed 0.1% by weight in homogeneous material)

<sup>(3)</sup> MSL, Peak Temp. -- The Moisture Sensitivity Level rating according to the JEDEC industry standard classifications, and peak solder temperature.

**Important Information and Disclaimer:**The information provided on this page represents TI's knowledge and belief as of the date that it is provided. TI bases its knowledge and belief on information provided by third parties, and makes no representation or warranty as to the accuracy of such information. Efforts are underway to better integrate information from third parties. TI has taken and continues to take reasonable steps to provide representative and accurate information but may not have conducted destructive testing or chemical analysis on incoming materials and chemicals. TI and TI suppliers consider certain information to be proprietary, and thus CAS numbers and other limited information may not be available for release.

In no event shall TI's liability arising out of such information exceed the total purchase price of the TI part(s) at issue in this document sold by TI to Customer on an annual basis.

## IMPORTANT NOTICE

Texas Instruments Incorporated and its subsidiaries (TI) reserve the right to make corrections, modifications, enhancements, improvements, and other changes to its products and services at any time and to discontinue any product or service without notice. Customers should obtain the latest relevant information before placing orders and should verify that such information is current and complete. All products are sold subject to TI's terms and conditions of sale supplied at the time of order acknowledgment.

TI warrants performance of its hardware products to the specifications applicable at the time of sale in accordance with TI's standard warranty. Testing and other quality control techniques are used to the extent TI deems necessary to support this warranty. Except where mandated by government requirements, testing of all parameters of each product is not necessarily performed.

TI assumes no liability for applications assistance or customer product design. Customers are responsible for their products and applications using TI components. To minimize the risks associated with customer products and applications, customers should provide adequate design and operating safeguards.

TI does not warrant or represent that any license, either express or implied, is granted under any TI patent right, copyright, mask work right, or other TI intellectual property right relating to any combination, machine, or process in which TI products or services are used. Information published by TI regarding third-party products or services does not constitute a license from TI to use such products or services or a warranty or endorsement thereof. Use of such information may require a license from a third party under the patents or other intellectual property of the third party, or a license from TI under the patents or other intellectual property of TI.

Reproduction of TI information in TI data books or data sheets is permissible only if reproduction is without alteration and is accompanied by all associated warranties, conditions, limitations, and notices. Reproduction of this information with alteration is an unfair and deceptive business practice. TI is not responsible or liable for such altered documentation. Information of third parties may be subject to additional restrictions.

Resale of TI products or services with statements different from or beyond the parameters stated by TI for that product or service voids all express and any implied warranties for the associated TI product or service and is an unfair and deceptive business practice. TI is not responsible or liable for any such statements.

TI products are not authorized for use in safety-critical applications (such as life support) where a failure of the TI product would reasonably be expected to cause severe personal injury or death, unless officers of the parties have executed an agreement specifically governing such use. Buyers represent that they have all necessary expertise in the safety and regulatory ramifications of their applications, and acknowledge and agree that they are solely responsible for all legal, regulatory and safety-related requirements concerning their products and any use of TI products in such safety-critical applications, notwithstanding any applications-related information or support that may be provided by TI. Further, Buyers must fully indemnify TI and its representatives against any damages arising out of the use of TI products in such safety-critical applications.

TI products are neither designed nor intended for use in military/aerospace applications or environments unless the TI products are specifically designated by TI as military-grade or "enhanced plastic." Only products designated by TI as military-grade meet military specifications. Buyers acknowledge and agree that any such use of TI products which TI has not designated as military-grade is solely at the Buyer's risk, and that they are solely responsible for compliance with all legal and regulatory requirements in connection with such use.

TI products are neither designed nor intended for use in automotive applications or environments unless the specific TI products are designated by TI as compliant with ISO/TS 16949 requirements. Buyers acknowledge and agree that, if they use any non-designated products in automotive applications, TI will not be responsible for any failure to meet such requirements.

Following are URLs where you can obtain information on other Texas Instruments products and application solutions:

### Products

Amplifiers	<a href="http://amplifier.ti.com">amplifier.ti.com</a>
Data Converters	<a href="http://dataconverter.ti.com">dataconverter.ti.com</a>
DLP® Products	<a href="http://www.dlp.com">www.dlp.com</a>
DSP	<a href="http://dsp.ti.com">dsp.ti.com</a>
Clocks and Timers	<a href="http://www.ti.com/clocks">www.ti.com/clocks</a>
Interface	<a href="http://interface.ti.com">interface.ti.com</a>
Logic	<a href="http://logic.ti.com">logic.ti.com</a>
Power Mgmt	<a href="http://power.ti.com">power.ti.com</a>
Microcontrollers	<a href="http://microcontroller.ti.com">microcontroller.ti.com</a>
RFID	<a href="http://www.ti-rfid.com">www.ti-rfid.com</a>
RF/IF and ZigBee® Solutions	<a href="http://www.ti.com/lprf">www.ti.com/lprf</a>

### Applications

Audio	<a href="http://www.ti.com/audio">www.ti.com/audio</a>
Automotive	<a href="http://www.ti.com/automotive">www.ti.com/automotive</a>
Broadband	<a href="http://www.ti.com/broadband">www.ti.com/broadband</a>
Digital Control	<a href="http://www.ti.com/digitalcontrol">www.ti.com/digitalcontrol</a>
Medical	<a href="http://www.ti.com/medical">www.ti.com/medical</a>
Military	<a href="http://www.ti.com/military">www.ti.com/military</a>
Optical Networking	<a href="http://www.ti.com/opticalnetwork">www.ti.com/opticalnetwork</a>
Security	<a href="http://www.ti.com/security">www.ti.com/security</a>
Telephony	<a href="http://www.ti.com/telephony">www.ti.com/telephony</a>
Video & Imaging	<a href="http://www.ti.com/video">www.ti.com/video</a>
Wireless	<a href="http://www.ti.com/wireless">www.ti.com/wireless</a>

Mailing Address: Texas Instruments, Post Office Box 655303, Dallas, Texas 75265  
Copyright © 2009, Texas Instruments Incorporated

## Looking for pricing, stock, or lifecycle information?

Click below to explore more details on WIN SOURCE:

 [View OPA2111KP](#) on WIN SOURCE

 [Texas Instruments](#) Information

## Optimize Your Supply Chain with WIN SOURCE Solutions

-  Global Sourcing Solution
-  Obsolete Management
-  Cost Control Management
-  Shortage Management
-  Alternative Solution
-  Excess Inventory Management