



THE DATASHEET OF
1N4685



ALSO
AVAILABLE IN
SURFACE
MOUNT

DESCRIPTION

The 1N4678 thru 1N4717 series of 0.5 watt Zener Voltage Regulators provides a selection from 1.8 to 43 volts in standard 5% tolerances as well as tighter tolerances identified by different suffix letters on the part number. These glass axial-leaded DO-7 Zeners also have an internal-metallurgical-bond similar to other military requirements for these packages. Microsemi also offers numerous other Zener products to meet higher and lower power applications.

APPEARANCE

DO-7
(DO-204AA)

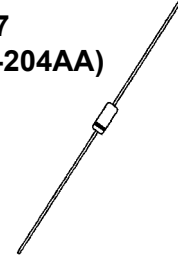

IMPORTANT: For the most current data, consult MICROSEMI's website: <http://www.microsemi.com>

FEATURES

- JEDEC registered 1N4678 thru 1N4717
- Internally solder bonded
- Options for screening in accordance with MIL-PRF-19500 for JAN, JANTX, JANTXV, and JANS are available by adding MQ, MX, MV, or MSP prefixes respectively to part numbers as well as "-1" suffix
- Surface Mount available in DO-213AA package outline by adding a UR or UR-1 (see separate data sheet for 1N4678UR thru 1N4717UR-1)
- DO-35 glass body axial-leaded Zener equivalents are also available (see separate data sheet)

APPLICATIONS / BENEFITS

- Regulates voltage over a broad operating current and temperature range
- Guaranteed maximum voltage regulation 10 μ A to 100 μ A
- Voltage selection from 1.8 to 43 V
- Standard voltage tolerances are plus/minus 5% with no suffix
- Tight tolerances available in plus or minus 2% or 1% with C or D suffix respectively
- Flexible axial-lead mounting terminals
- Nonsensitive to ESD per MIL-STD-750 Method 1020
- Capacitance also specified (see Figure 3)
- Inherently radiation hard as described in Microsemi MicroNote 050

MAXIMUM RATINGS

- Operating and Storage temperature: -65°C to $+175^{\circ}\text{C}$
- Thermal Resistance: 300°C/W junction to lead at 3/8 (10 mm) lead length from body, or 360°C/W junction to ambient when mounted on FR4 PC board (1 oz Cu) with 4 mm^2 copper pads and track width 1 mm, length 25 mm
- Steady-State Power: 0.5 watts at $T_L \leq 25^{\circ}\text{C}$ 3/8 inch (10 mm) from body or 0.417 W at $T_A \leq 25^{\circ}\text{C}$ when mounted on FR4 PC board as described for thermal resistance (see Figure 2 for derating)
- Forward voltage @200 mA: 1.1 volts (maximum)
- Solder Temperatures: 260°C for 10 s (max)

MECHANICAL AND PACKAGING

- CASE: Hermetically sealed axial-lead glass DO-7 (DO-204AA) package
- TERMINALS: Leads, tin-lead plated solderable per MIL-STD-750, method 2026
- POLARITY: Cathode indicated by band where diode is to be operated with the banded end positive with respect to the opposite end for Zener regulation
- MARKING: Part number
- TAPE & REEL option: Standard per EIA-296 (add "TR" suffix to part number)
- WEIGHT: 0.2 grams
- See package dimensions on last page

*** ELECTRICAL CHARACTERISTICS @ 25°C**

JEDEC TYPE NUMBER (Note 1)	NOMINAL ZENER VOLTAGE (Note 3)	ZENER TEST CURRENT	MAXIMUM VOLTAGE REGULATION (Note 2 & 3)	MAXIMUM REVERSE LEAKAGE CURRENT		MAXIMUM DC ZENER CURRENT*
	V_Z	I_{ZT}	ΔV_Z	$I_R @ V_R$		I_{ZM}
	VOLTS	μA	VOLTS	μA	VOLTS	mA
1N4678	1.8	50	0.70	7.5	1.0	240
1N4679	2.0	50	0.70	5.0	1.0	220
1N4680	2.2	50	0.75	4.0	1.0	200
1N4681	2.4	50	0.80	2.0	1.0	190
1N4682	2.7	50	0.85	1.0	1.0	180
1N4683	3.0	50	0.90	0.8	1.0	170
1N4684	3.3	50	0.95	7.5	1.5	160
1N4685	3.6	50	0.95	7.5	2.0	150
1N4686	3.9	50	0.97	5.0	2.0	140
1N4687	4.3	50	0.99	4.0	2.0	130
1N4688	4.7	50	0.99	10.0	3.0	120
1N4689	5.1	50	0.97	10.0	3.0	110
1N4690	5.6	50	0.96	10.0	4.0	100
1N4691	6.2	50	0.95	10.0	5.0	90
1N4692	6.8	50	0.90	10.0	5.1	70
1N4693	7.5	50	0.75	10.0	5.7	63.6
1N4694	8.2	50	0.50	1.0	6.2	58.0
1N4695	8.7	50	0.10	1.0	6.6	54.8
1N4696	9.1	50	0.08	1.0	6.9	52.4
1N4697	10.0	50	0.10	1.0	7.6	49.6
1N4698	11.0	50	0.11	0.05	8.4	43.2
1N4699	12.0	50	0.12	0.05	9.1	40.8
1N4700	13.0	50	0.13	0.05	9.8	38.0
1N4701	14.0	50	0.14	0.05	10.6	35.0
1N4702	15.0	50	0.15	0.05	11.4	32.6
1N4703	16.0	50	0.16	0.05	12.1	30.8
1N4704	17.0	50	0.17	0.05	12.9	29.0
1N4705	18.0	50	0.18	0.05	13.6	26.4
1N4706	19.0	50	0.19	0.05	14.4	25.0
1N4707	20.0	50	0.20	0.01	15.2	23.8
1N4708	22.0	50	0.22	0.01	16.7	21.6
1N4709	24.0	50	0.24	0.01	18.2	19.8
1N4710	25.0	50	0.25	0.01	19.0	19.0
1N4711	27.0	50	0.27	0.01	20.4	17.6
1N4712	28.0	50	0.28	0.01	21.2	17.0
1N4713	30.0	50	0.30	0.01	22.8	15.8
1N4714	33.0	50	0.33	0.01	25.0	14.4
1N4715	36.0	50	0.36	0.01	27.3	13.2
1N4716	39.0	50	0.39	0.01	29.6	12.2
1N4717	43.0	50	0.43	0.01	32.6	11.0

*JEDEC registered data except I_{ZM} has been increased (doubled) for 500 mW power dissipation capabilities

- NOTES:**
1. All types as shown are +/-5% tolerance. Also available in 2% and 1% tolerance by adding suffix C and D respectively.
 2. $\Delta V_Z @ 100\mu A$ minus $V_Z @ 10\mu A$.
 3. The electrical characteristics are measured after allowing the device to stabilize for 20 seconds when mounted with 3/8" minimum lead length from the base.

GRAPHS

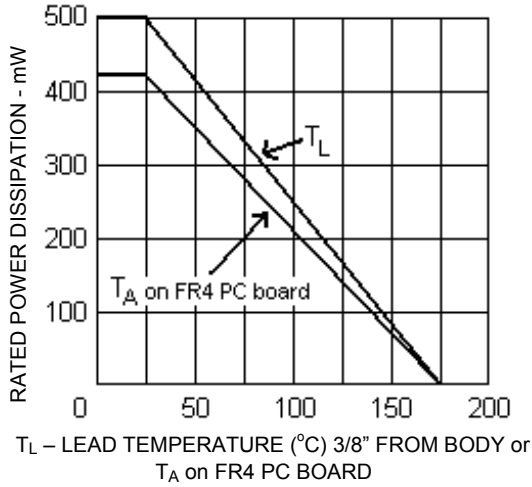

FIGURE 1
POWER DERATING CURVE

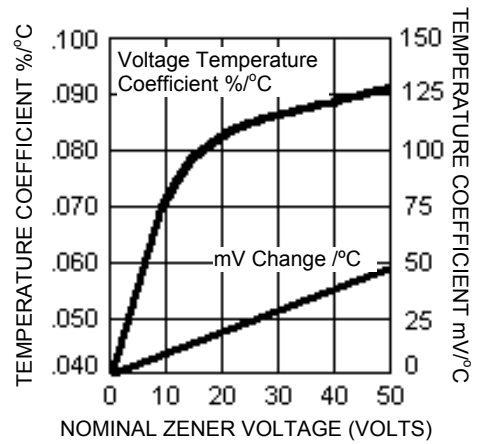

FIGURE 2
ZENER VOLTAGE TEMPERATURE COEFFICIENT vs. ZENER VOLTAGE

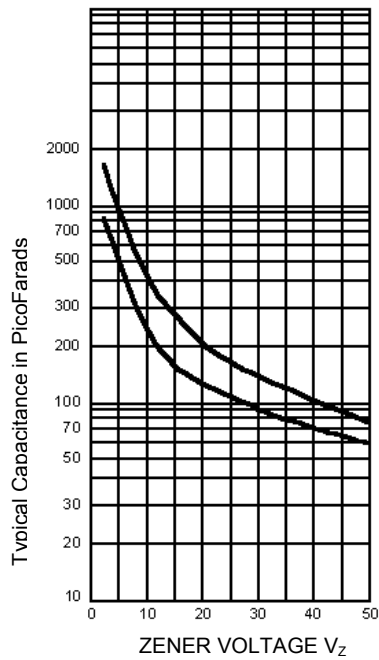
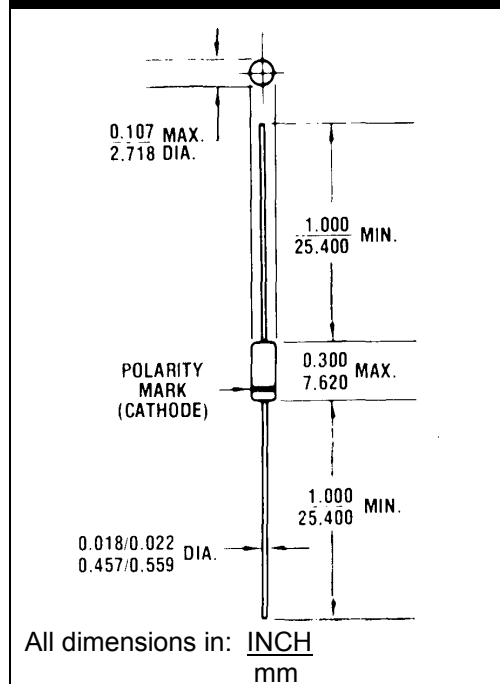



FIGURE 3
CAPACITANCE vs. V_Z CURVE

DO-7 PACKAGE DIMENSIONS



Looking for pricing, stock, or lifecycle information?

Click below to explore more details on WIN SOURCE:

-  [View 1N4685 on WIN SOURCE](#)
-  [Microchip Technology](#) Information

Optimize Your Supply Chain with WIN SOURCE Solutions

-  Global Sourcing Solution
-  Obsolete Management
-  Cost Control Management
-  Shortage Management
-  Alternative Solution
-  Excess Inventory Management