



**THE DATASHEET OF  
AFE5809ZCF**



# AFE5809 Fully Integrated, 8-Channel Ultrasound Analog Front End With Passive CW Mixer, and Digital I/Q Demodulator, 0.75 nV/rtHz, 14, 12-Bit, 65 MSPS, 158 mW/CH

## 1 Features

- 8-Channel Complete Analog Front-End
  - LNA, VCAT, PGA, LPF, ADC, and CW Mixer
- Programmable Gain Low-Noise Amplifier (LNA)
  - 24-, 18-, 12-dB Gain
  - 0.25-, 0.5-, 1- $V_{PP}$  Linear Input Range
  - 0.63-, 0.7-, 0.9-nV/rtHz Input Referred Noise
  - Programmable Active Termination
- 40-dB Low-Noise Voltage Controlled Attenuator (VCAT)
- 24-/30-dB Programmable Gain Amplifier (PGA)
- Third-Order Linear Phase Low-Pass Filter (LPF)
  - 10, 15, 20, 30 MHz
- 14-Bit Analog-to-Digital Converter (ADC)
  - 77 dBFS SNR at 65 MSPS
  - LVDS Outputs
- Noise, Power Optimizations (Without Digital Demodulator)
  - 158 mW/CH at 0.75 nV/rtHz, 65 MSPS
  - 101 mW/CH at 1.1 nV/rtHz, 40 MSPS
  - 80 mW/CH at CW Mode
- Excellent Device-to-Device Gain Matching
  - $\pm 0.5$  dB (Typical) and  $\pm 1$  dB (Maximum)
- Digital I/Q Demodulator after ADC
  - Wide Range Demodulation Frequency
  - <1 kHz Frequency Resolution
  - Decimation Filter Factor  $M = 1$  to 32
  - 16xM Tap FIR Decimation Filter
  - LVDS Rate Reduction after Demodulation
  - On-Chip RAM With 32 Preset Profiles
- Low Harmonic Distortion
- Low-Frequency Sonar Signal Processing

- Fast and Consistent Overload Recovery
- Passive Mixer for Continuous Wave Doppler (CWD)
  - Low Close-in Phase Noise  $-156$  dBc/Hz at 1 kHz off 2.5-MHz Carrier
  - Phase Resolution of  $1/16\lambda$
  - Support 16x, 8x, 4x, and 1x CW Clocks
  - 12-dB Suppression on Third and Fifth Harmonics
  - Flexible Input Clocks
- Small Package: 15 mm  $\times$  9 mm, 135-BGA

## 2 Applications

- Medical Ultrasound Imaging
- Nondestructive Evaluation Equipments
- Sonar Applications

## 3 Description

The AFE5809 device is a highly-integrated analog front-end (AFE) solution specifically designed for ultrasound systems in which high performance and small size are required. The AFE5809 device integrates a complete time-gain-control (TGC) imaging path and a CWD path. The device also enables users to select one of various power and noise combinations to optimize system performance. Therefore, the AFE5809 device is a suitable ultrasound AFE solution not only for high-end systems, but also for portable ones.

### Device Information<sup>(1)</sup>

PART NUMBER	PACKAGE	BODY SIZE (NOM)
AFE5809	NFBGA (135)	15.00 mm $\times$ 9.00 mm

(1) For all available packages, see the orderable addendum at the end of the data sheet.

## Block Diagram

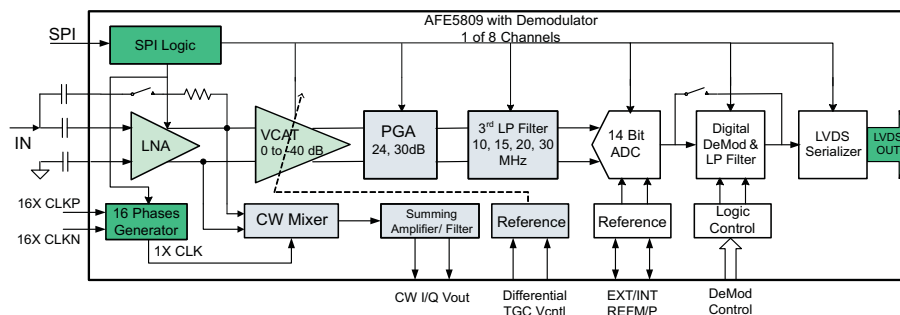

## Table of Contents

<b>1 Features</b> .....	1	8.6 Register Maps .....	52
<b>2 Applications</b> .....	1	<b>9 Application and Implementation</b> .....	81
<b>3 Description</b> .....	1	9.1 Application Information .....	81
<b>4 Revision History</b> .....	2	9.2 Typical Application .....	82
<b>5 Description (continued)</b> .....	6	9.3 System Example .....	96
<b>6 Pin Configuration and Functions</b> .....	7	9.4 Do's and Don'ts .....	98
<b>7 Specifications</b> .....	10	<b>10 Power Supply Recommendations</b> .....	99
7.1 Absolute Maximum Ratings .....	10	10.1 Power/Performance Optimization .....	99
7.2 ESD Ratings .....	11	10.2 Power Management Priority .....	100
7.3 Recommended Operating Conditions .....	11	10.3 Partial Power-Up and Power-Down Mode .....	100
7.4 Thermal Information .....	11	10.4 Complete Power-Down Mode .....	100
7.5 Electrical Characteristics .....	12	10.5 Power Saving in CW Mode .....	101
7.6 Digital Demodulator Electrical Characteristics .....	16	<b>11 Layout</b> .....	101
7.7 Digital Characteristics .....	17	11.1 Layout Guidelines .....	101
7.8 Switching Characteristics .....	18	11.2 Layout Example .....	102
7.9 SPI Switching Characteristics .....	18	<b>12 Device and Documentation Support</b> .....	106
7.10 Output Interface Timing Requirements (14-bit) .....	19	12.1 Device Support .....	106
7.11 Typical Characteristics .....	21	12.2 Documentation Support .....	106
<b>8 Detailed Description</b> .....	31	12.3 Community Resources .....	106
8.1 Overview .....	31	12.4 Trademarks .....	106
8.2 Functional Block Diagram .....	31	12.5 Electrostatic Discharge Caution .....	106
8.3 Feature Description .....	32	12.6 Glossary .....	106
8.4 Device Functional Modes .....	48	<b>13 Mechanical, Packaging, and Orderable Information</b> .....	106
8.5 Programming .....	48		

## 4 Revision History

NOTE: Page numbers for previous revisions may differ from page numbers in the current version.

Changes from Revision D (January 2014) to Revision E	Page
• Added <i>ESD Ratings</i> table, <i>Feature Description</i> section, <i>Device Functional Modes</i> , <i>Application and Implementation</i> section, <i>Power Supply Recommendations</i> section, <i>Layout</i> section, <i>Device and Documentation Support</i> section, and <i>Mechanical, Packaging, and Orderable Information</i> section .....	1
• Changed N4 and N6 to "When LDO_EN L4 = 1.8 V, demodulator digital power supply generated internally. These two pins should be separated on the PCB and decoupled respectively with 0.1-μF capacitors. When LDO_EN L4=DVSS, the internal LDOs are disabled. External higher performance 1.4-V supply can be applied to N4 and N6 for minimizing digital noise emission. " .....	9
• Changed L6 pin description to "Enable/Disable AFE's internal LDO regulators. When it is tied to 1.8-V DVDD or Logic "1", AFE's internal LDO is enabled. When it is tied to DVSS or Logic "0", AFE's internal LDO is disabled and external 1.4V supply can be applied at N4 and N6 pins, that is, DVDD_LDO1, DVDD_LDO2. " .....	9
• Changed M6 pin description to "Sets the internal LDO voltage. Logic "1" or tie to 1.8-V DVDD sets the LDO output as 1.4V. It can be tied to DVSS when the internal LDO is disabled. " .....	9
• Added a note to pin H8 "When the complete power-down mode is enabled, the digital demodulator may lose register settings. Therefore it is required to reconfigure the demodulator registers, filter coefficient memory and profile memory after exiting the complete power-down mode. " .....	9
• Added a note to pin L7 "Note: TX_SYNC signal must be synchronized with ADC CLK. Typically pulse repetition frequency (PRF) signal can be used for TX_SYNC_IN. " .....	10
• Added "DVDD_LDO1/2 (external supplied)" in <i>Recommended Operating Conditions</i> .....	11
• Added LDO_EN V <sub>IH</sub> , V <sub>IL</sub> , I <sub>IH</sub> , I <sub>IL</sub> in <i>Digital Demodulator Electrical Characteristics</i> .....	16
• Deleted "(for output data and frame clock)" .....	19
• Added a note "TI recommends to synchronize SCLK to ADC CLK... " .....	49
• Added a note to Register 0 [0]"Register 0 is a write only register." .....	52

## Revision History (continued)

• Added a note to Register 0[1] "When this bit is set to 0, device will always operate in write mode; and when it is set to 1, device will be in read mode. Multiple reading or writing events can be performed when this bit is set to 1 or 0 correspondingly. Register 0 is a write only register." .....	52
• Added a note "When the complete power-down mode is enabled, the digital demodulator may lose register settings. Therefore it is required to reconfigure the demodulator registers, filter coefficient memory and profile memory after exiting the complete power down mode. " .....	52
• Added a note to Register 3[7:0] "Suppose device is giving digital output of "11001100001111". After enabling this bit, output of device will become "00110011110000". Please note this function is not applicable for ADC test patterns and in demod mode." .....	53
• Added "Test pattern from the ADC output stage can NOT be sent to the demodulator; it can only be sent to the LVDS serializer when the demodulator is off. " to <a href="#">TEST_PATTERN_MODES: Address: 2[15:13]</a> .....	57
• Added a note for Reg.0x3D[15] " Note: This bit is ONLY valid when PGA=24dB." .....	60
• Changed Demod Reg0xA[12] to DHPF. ....	63
• Added Notes to the demod Reg0x14~17"DC_REMOVAL_X_X registers are write-only" .....	64
• Move "RF Mode" before <a href="#">Table 12</a> . ....	65
• Added Shifted output figures when DEC_SHIFT_SCALE=0 or 1 .....	70
• Added note "A trigger is required to make new settings effective, such as profile RAM, coefficient RAM, and PROFILE_INDX Reg.0x0E[15:11] —either an external trigger event through the TX_SYNC_IN pin or a manual trigger event through Register 0[2]. PROFILE_INDX Reg.0x0E[15:11] must be reprogrammed to ensure new profile and filter RAMs loaded correctly. ADC CLK is required during profile and coefficient RAM programming. "in <a href="#">Profile RAM and Coefficient RAM</a> .....	72
• Added "when DC_REMOVAL_BYPASS 10[0] = 0" to the caption of <a href="#">Figure 92</a> " .....	75
• Changed " sample followed after sync word" to "demod output after sync word" .....	77
• Corrected <a href="#">Equation 9</a> .....	79
• Corrected <a href="#">Equation 10</a> .....	79
• Corrected <a href="#">Equation 11</a> .....	79
• Added <a href="#">Figure 103</a> .....	88
• Added "CM_BYP=1.5V" in <a href="#">Figure 106</a> .....	91
• Added <a href="#">System Example</a> .....	96
• Moved <a href="#">Figure 113</a> to <a href="#">Power Supply Recommendations</a> and added "When the demodulator power DVDD_LDO1 and DVDD_LDO2 are supplied externally, it should be powered up 1ms after DVDD. LDOs for external DVDD_LDO1 and DVDD_LDO2 can be powered down if the demodulator is not used".....	99
• Deleted "The digital demodulator also has four power-down controls... in <a href="#">Power Management Priority</a> " .....	100
• Added a note "When the complete power-down mode is enabled, the digital demodulator may lose register settings. Therefore, it is required to reconfigure the demodulator registers, filter coefficient memory, and profile memory after exiting the complete power-down mode. " .....	101
• Edited <a href="#">Layout Guidelines</a> : "To avoid noise coupling through supply pins, it is recommended to keep sensitive input net classes, such as INM, INP, ACT pins, away from AVDD 3.3 V, AVDD_5V, DVDD, AVDD_ADC, DVDD_LDO1/2 nets or planes. For example, vias connected to these pins should NOT be routed across any supply plane. That is to avoid power planes under INM, INP, and ACT pins. " .....	101

## Changes from Revision C (January 2013) to Revision D

**Page**

• Changed Feature: Decimation Filter Factor M = 1 to 64To: ...M = 1 to 32 .....	1
• Added a note for new silicon features.....	6
• Changed pin description of CLKM_16X from "In the 1x CW clock mode, this pin becomes the quadrature-phase 1x CLKM for the CW mixer" to "... in-phase 1x CLKM for the CW mixer" .....	8
• Changed pin description of CLKP_16X from "In the 1x CW clock mode, this pin becomes the quadrature-phase 1x CLKP for the CW mixer" to "... in-phase 1x CLKP for the CW mixer" .....	8
• Changed pin description of CLKM_1X from "In the 1x CW clock mode, this pin becomes the in-phase 1x CLKP for	

the CW mixer" to "... quadrature-phase 1x CLKP for the CW mixer" .....	8
• Changed pin description of CLKP_1X from "In the 1x CW clock mode, this pin becomes the in-phase 1x CLKP for the CW mixer" to "... quadrature-phase 1x CLKP for the CW mixer" .....	8
• Corrected AVDD_5V current from 16.5 mA to 26 mA .....	15
• Changed 64x decimation factor to 32x decimation factor in DVDD consumption at 65 MSPS in <a href="#">Digital Demodulator Electrical Characteristics</a> .....	16
• Changed 64x decimation factor to 32x decimation factor in DVDD consumption at 40 MSPS in <a href="#">Digital Demodulator Electrical Characteristics</a> .....	16
• Changed Input Clock to Bit Clock.....	19
• Changed Input Clock to Bit Clock.....	19
• Corrected a typo in Reg0x2[15:13], that is changed 0x2[15:3] to 0x2[15:13] .....	53
• Added a note to Reg0x15[0] "This HPF feature is only available when the demodulation block is disabled." .....	53
• Added a note to Reg0x21[0] "This HPF feature is only available when the demodulation block is disabled." .....	54
• Added a note "These digital processing features are only available when the demodulation block is disabled." .....	54
• Added a note in the Register 51[3:1] description, "Note: 0x3D[14], that is, 5 MHz LPF, should be set a 0. " .....	57
• Added a note in the Register 57[7:5] description, "Note: Register 61[15] should be set as 0; otherwise PGA_CLAMP_LEVEL is affected by Register 61[15]." .....	57
• Added Register 61[15:13] description. ....	59
• Added and reorganized Description of LNA Input Impedances Configuration.....	60
• Added <a href="#">Table 7</a> .....	61
• Added a note for Reg0x1F[5:0] "it is from 1 to 32." .....	65
• Changed "0x521" to "0x121F" in .....	65
• Changed "MODULATE_BYPASS = 1" to "MODULATE_BYPASS = 0" in .....	65
• Highlighted the note about Channel Selection. ....	66
• Added <a href="#">Figure 87</a> .....	68
• Added "FIR Filter Delay versus TX_TRIG Timing" and "Expression of Decimation Filter Response" .....	76
• Updated figure reference and added a link in <a href="#">Expression of Decimation Filter Response</a> .....	78
• Added text " In high channel count premium systems, the $V_{CNTLMP}$ noise requirement is higher." .....	88
• Added "to avoid power planes under INM, INP, and ACT pins." .....	101

**Changes from Revision B (September 2012) to Revision C Page**

• Added a note "The above timing data can be applied to 12-bit or 16-bit LVDS rates" .....	19
• Changed 'SIN' to '-SIN' and 'C8' to 'Cn' in <a href="#">Figure 61</a> .....	32
• Added "The maximum PGA output level can be above 2 Vpp even with the clamp circuit enabled" in the PGA description. ....	35
• Added a note "The local oscillator inputs of the passive mixer are $\cos(\omega t)$ for I-CH and $\sin(\omega t)$ for Q-CH" .....	36
• Changed "10 $\Omega$ " to "10 to 15 $\Omega$ " in <a href="#">Figure 67</a> .....	37
• Added a note "The digital demodulator is based on a conventional down converter, that is, $-\sin(\omega_0 t)$ is used for Q phase. ....	44
• Changed SPI pulldown resistors from "100 k $\Omega$ " to "20 k $\Omega$ " .....	48
• Added a note to register 0x3[14:13] "Make sure the settings aligning with the demod register 0x3[14:13]" .....	53
• Added Note to PGA_CLAMP_LEVEL: "The maximum PGA output level can exceed 2Vpp with the clamp circuit enabled." .....	57
• Changed from "For RF mode (passing 14 bits only)... 0xC3[14:13] to '00' " to "...0xC3[14:13] to '10' " in .....	66
• Changed List item From: "The internal 32-bit filter output" To: The internal 36-bit filter output" .....	70
• Changed text following <a href="#">Table 21</a> From: "the block index, from 0 to (-1)" To: "the block index, from 0 to (M - 1) .....	73
• Added text "TI recommends that $V_{CNTLMP}$ noise is below 25 nV/rtHz at 1 kHz and 5 nV/rtHz at 50 kHz. " .....	88
• Added a note "The local oscillator inputs of the passive mixer are $\cos(\omega t)$ for I-CH and $\sin(\omega t)$ for Q-CH " .....	92

- Added "AVDD\_5V needs to be away from sensitive input pins" ..... [101](#)
- 

**Changes from Revision A (September 2012) to Revision B** **Page**

---

- Deleted Feature: "Programmable Digital I/Q Demodulator" ..... [1](#)
  - Changed Feature: Noise, Power Optimizations (Without Digital Demodulator) From: 99 mW/CH at 1.1 nV/rHz, 40 MSPS To: 101 mW/CH at 1.1 nV/rHz, 40 MSPS ..... [1](#)
  - Changed Feature: Excellent Device-to-Device Gain Matching From:  $\pm 0.5$  dB (typical) and  $\pm 0.9$  dB (max) To:  $\pm 0.5$  dB (typical) and  $\pm 1$  dB (max) ..... [1](#)
  - Changed Gain matching values From MIN =  $-0.9$  dB to MIN =  $-1$  dB and From: MAX =  $0.9$  dB to MAX =  $1$  dB ..... [13](#)
  - Added Note: "In the low power and medium-power modes, PGA\_CLAMP is disabled for saving power if 51[7] = 0" ..... [35](#)
  - Added a note to PGA\_CLAMP\_LEVEL: "in the low-power and medium-power modes, PGA\_CLAMP is disabled for saving power if 51[7] = 0" ..... [57](#)
- 

**Changes from Original (September 2012) to Revision A** **Page**

---

- Changed the device From: Product Preview To: Production ..... [1](#)
-

## 5 Description (continued)

The AFE5809 device contains eight channels of voltage controlled amplifier (VCA), 14, and 12-bit ADC, and CW mixer. The VCA includes LNA, VCAT, PGA, and LPF. The LNA gain is programmable to support 250 mV<sub>PP</sub> to 1 V<sub>PP</sub> input signals. Programmable active termination is also supported by the LNA. The ultra-low noise VCAT provides an attenuation control range of 40 dB and improves overall low-gain SNR, which benefits harmonic imaging and near-field imaging. The PGA provides gain options of 24 and 30 dB. Before the ADC, a LPF can be configured as 10, 15, 20, or 30 MHz to support ultrasound applications with different frequencies. In addition, the signal chain of the AFE5809 device can handle signal frequency lower than 100 kHz, which enables the device to be used in both sonar and medical applications. The high-performance 14-bit/65-MSPS ADC in the AFE5809 device achieves 77-dBFS SNR. It ensures excellent SNR at low chain gain. The ADC's LVDS outputs enable flexible system integration desired for miniaturized systems.

The AFE5809 device integrates a low-power passive mixer and a low-noise summing amplifier to accomplish on-chip CWD beamformer. 16 selectable phase-delays can be applied to each analog input signal. Meanwhile, a unique third- and fifth-order harmonic suppression filter is implemented to enhance CW sensitivity.

The AFE5809 device also includes a digital in-phase and quadrature (I/Q) demodulator and a low-pass decimation filter. The main purpose of the demodulation block is to reduce the LVDS data rate and improve overall system power efficiency. The I/Q demodulator can accept ADC output with up to 65 MSPS sampling rate and 14-bit resolution. For example, after digital demodulation and 4× decimation filtering, the data rate for either in-phase or quadrature output is reduced to 16.25 MSPS and the data resolution is improved to 16 bits, consequently. Hence, the overall LVDS trace reduction can be a factor of 2. This demodulator can be bypassed and powered down completely if it is not needed.

The AFE5809 device is available in a 15-mm × 9-mm, 135-pin BGA package, and it is specified for operation from 0°C to 85°C.

---

### NOTE

AFE5809 with date code later than 2014, that is date code >41XXXX, has below additional features which can be enabled by Register 61[15,14,13]. Existing analog performance remains the same.

- 61[13] enables an additional voltage clamp at the V2I input of the PGA. This limits the amount of overload signal the PGA sees.
  - 61[14] enables a first-order 5-MHz LPF filter to suppress signals >5 MHz or high-order harmonics.
  - 61[15] enables a –6-dB PGA clamp setting. The actual PGA output is less than the ADC's full-scale amplitude, 2 V<sub>pp</sub>.
-

## 6 Pin Configuration and Functions

**ZCF Package  
135-Pin NFBGA  
Bottom View**

R	D7P	D6P	D5P	FCLKP	DVSS	DCLKP	D4P	D3P	D2P
P	D7M	D6M	D5M	FCLKM	DVSS	DCLKM	D4M	D3M	D2M
N	D8P	D8M	DVDD	DVDD_LDO1	DVSS	DVDD_LDO2	DVDD	D1M	D1P
M	AVDD_ADC	AVDD_ADC	VREF_IN	REFP	DNC	LDO_SETV	SPI_DIG_EN	DNC	SDOUT
L	CLKP_ADC	CLKM_ADC	AVDD_ADC	REFM	DNC	LDO_EN	TX_SYNC_IN	PDN_ADC	SEN
K	AVDD	AVDD_5V	VCNTLP	VCNTLM	VHIGH	AVSS	DNC	AVDD_ADC	SDATA
J	CW_QP_AMPINP	CW_QP_AMPINM	AVSS	AVSS	AVSS	AVDD_ADC	AVDD_ADC	PDN_VCA	SCLK
H	CW_QP_OUTM	CW_QP_OUTP	AVSS	AVSS	AVSS	AVSS	AVSS	PDN_GLOBAL	RESET
G	AVSS	AVSS	AVSS	AVSS	AVSS	AVSS	AVSS	CLKP_1X	CLKM_1X
F	CW_IP_OUTM	CW_IP_OUTP	AVSS	AVSS	AVSS	AVSS	AVSS	CLKP_16X	CLKM_16X
E	CW_IP_AMPINP	CW_IP_AMPINM	AVSS	AVSS	AVSS	AVSS	AVSS	AVDD	AVDD
D	AVSS	AVSS	AVSS	AVSS	AVSS	AVSS	AVSS	AVDD	AVDD
C	AVSS	INM8	INM7	INM6	INM5	INM4	INM3	INM2	INM1
B	CM_BYP	ACT8	ACT7	ACT6	ACT5	ACT4	ACT3	ACT2	ACT1
A	AVDD	INP8	INP7	INP6	INP5	INP4	INP3	INP2	INP1
	1	2	3	4	5	6	7	8	9

Columns

### Pin Functions

PIN		DESCRIPTION
NAME	NO.	
ACT1 to ACT8	B9 to B2	Active termination input pins for CH1 to CH8
AVDD	A1	3.3-V analog supply for LNA, VCAT, PGA, LPF, and CWD blocks
	D8	
	D9	
	E8	
	E9	
	K1	
AVDD_5V	K2	5-V analog supply for LNA, VCAT, PGA, LPF, and CWD blocks
AVDD_ADC	J6	1.8-V analog power supply for ADC
	J7	
	K8	
	L3	
	M1	
	M2	
AVSS	C1	Analog ground
	D1 to D7	
	E3 to E7	
	F3 to F7	
	G1 to G7	
	H3 to H7	
	J3 to J5	
	K6	
CLKM_ADC	L2	Negative input of differential ADC clock. In the single-end clock mode, it can be tied to GND directly or through a 0.1- $\mu$ F capacitor.
CLKP_ADC	L1	Positive input of differential ADC clock. In the single-end clock mode, it can be tied to clock signal directly or through a 0.1- $\mu$ F capacitor.
CLKM_16X	F9	Negative input of differential CW 16 $\times$ clock. Tie to GND when the CMOS clock mode is enabled. In the 4 $\times$ and 8 $\times$ CW clock modes, this pin becomes the 4 $\times$ or 8 $\times$ CLKM input. In the 1 $\times$ CW clock mode, this pin becomes the in-phase 1 $\times$ CLKM for the CW mixer. Can be floated if CW mode is not used. See register 0x36[11:10].
CLKP_16X	F8	Positive input of differential CW 16 $\times$ clock. In 4 $\times$ and 8 $\times$ clock modes, this pin becomes the 4 $\times$ and 8 $\times$ CLKP input. In the 1 $\times$ CW clock mode, this pin becomes the in-phase 1 $\times$ CLKP for the CW mixer. Can be floated if CW mode is not used. See register 0x36[11:10].
CLKM_1X	G9	Negative input of differential CW 1 $\times$ clock. Tie to GND when the CMOS clock mode is enabled (refer to <a href="#">Figure 107</a> for details). In the 1 $\times$ clock mode, this pin is the quadrature-phase 1 $\times$ CLKM for the CW mixer. Can be floated if CW mode is not used.
CLKP_1X	G8	Positive input of differential CW 1 $\times$ clock. In the 1 $\times$ clock mode, this pin is the quadrature-phase 1 $\times$ CLKP for the CW mixer. Can be floated if CW mode is not used.
CM_BYP	B1	Bias voltage and bypass to ground. TI recommends 1 $\mu$ F. To suppress the ultra-low frequency noise, the designer can use 10 $\mu$ F.
CW_IP_AMPINM	E2	Negative differential input of the in-phase summing amplifier. External LPF capacitor must be connected between CW_IP_AMPINM and CW_IP_OUTP. This pin provides the current output for the CW mixer. This pin becomes the CH7 PGA negative output when PGA test mode is enabled. Can be floated if not used.
CW_IP_AMPINP	E1	Positive differential input of the in-phase summing amplifier. External LPF capacitor must be connected between CW_IP_AMPINP and CW_IP_OUTM. This pin provides the current output for the CW mixer. This pin becomes the CH7 PGA positive output when PGA test mode is enabled. Can be floated if not used.
CW_IP_OUTM	F1	Negative differential output for the in-phase summing amplifier. External LPF capacitor must be connected between CW_IP_AMPINP and CW_IP_OUTPM. Can be floated if not used.
CW_IP_OUTP	F2	Positive differential output for the in-phase summing amplifier. External LPF capacitor must be connected between CW_IP_AMPINM and CW_IP_OUTP. Can be floated if not used.

**Pin Functions (continued)**

PIN		DESCRIPTION
NAME	NO.	
CW_QP_AMPINM	J2	Negative differential input of the quadrature-phase summing amplifier. External LPF capacitor must be connected between CW_QP_AMPINM and CW_QP_OUTP. This pin provides the current output for the CW mixer. This pin becomes CH8 PGA negative output when PGA test mode is enabled. Can be floated if not used.
CW_QP_AMPINP	J1	Positive differential input of the quadrature-phase summing amplifier. External LPF capacitor must be connected between CW_QP_AMPINP and CW_QP_OUTM. This pin provides the current output for the CW mixer. This pin becomes CH8 PGA positive output when PGA test mode is enabled. Can be floated if not used.
CW_QP_OUTM	H1	Negative differential output for the quadrature-phase summing amplifier. External LPF capacitor must be connected between CW_QP_AMPINP and CW_QP_OUTM. Can be floated if not used.
CW_QP_OUTP	H2	Positive differential output for the quadrature-phase summing amplifier. External LPF capacitor must be connected between CW_QP_AMPINM and CW_QP_OUTP. Can be floated if not used.
D1M to D8M	N8	ADC CH1 to CH8 LVDS negative outputs
	P9 to P7	
	P3 to P1	
	N2	
D1P to D8P	N9	ADC CH1 to 8 LVDS positive outputs
	R9 to R7	
	R3 to R1	
	N1	
DCLKM	P6	LVDS bit clock (7x) negative output
DCLKP	R6	LVDS bit clock (7x) positive output
DVDD	N3	ADC digital and I/O power supply, 1.8 V
	N7	
DVSS	N5	ADC digital ground
	P5	
	R5	
DVDD_LDO1, DVDD_LDO2	N4	When LDO_EN L4 = 1.8 V, demodulator digital power supply generated internally. These two pins should be separated on the PCB and decoupled respectively with 0.1- $\mu$ F capacitors. When LDO_EN L4=DVSS, the internal LDOs are disabled. External higher performance 1.4-V supply can be applied to N4 and N6 for minimizing digital noise emission.
	N6	
FCLKM	P4	LVDS frame clock (1x) negative output
FCLKP	R4	LVDS frame clock (1x) positive output
INM1 to INM8	C9 to C2	CH1 to CH8 complementary analog inputs. Bypass to ground with $\geq 0.015$ - $\mu$ F capacitors. The HPF response of the LNA depends on the capacitors.
INP1 to INP8	A9 to A2	CH1 to CH8 analog inputs. AC couple to inputs with $\geq 0.1$ - $\mu$ F capacitors.
LDO_EN	L6	Enable/Disable AFE's internal LDO regulators. When it is tied to 1.8-V DVDD or Logic "1", AFE's internal LDO is enabled. When it is tied to DVSS or Logic "0", AFE's internal LDO is disabled and external 1.4-V supply can be applied at N4 and N6 pins, that is, DVDD_LDO1, DVDD_LDO2.
LDO_SETV	M6	Sets the internal LDO voltage. Logic "1" or tie to 1.8-V DVDD sets the LDO output as 1.4V. It can be tied to DVSS when the internal LDO is disabled.
PDN_ADC	L8	ADC partial (fast) power-down control pin with an internal pulldown resistor of 100 k $\Omega$ . Active high. Either 1.8-V or 3.3-V logic level can be used.
PDN_VCA	J8	VCA partial (fast) power-down control pin with an internal pulldown resistor of 20 k $\Omega$ . Active high. 3.3-V logic level should be used.
PDN_GLOBAL	H8	Global (complete) power-down control pin for the entire chip with an internal pulldown resistor of 20 k $\Omega$ . Active high. 3.3-V logic level should be used. <b>When the complete power-down mode is enabled, the digital demodulator may lose register settings. Therefore, it is required to reconfigure the demodulator registers, filter coefficient memory, and profile memory after existing the complete power-down mode.</b>
REFM	L4	0.5-V reference output in the internal reference mode. Must leave floated in the internal reference mode. TI recommends adding a test point on the PCB for monitoring the reference output
REFP	M4	1.5-V reference output in the internal reference mode. Must leave floated in the internal reference mode. TI recommends adding a test point on the PCB for monitoring the reference output

**Pin Functions (continued)**

PIN		DESCRIPTION
NAME	NO.	
RESET	H9	Hardware reset pin with an internal pulldown resistor of 20 kΩ. Active high. The designer can use 3.3-V logic level.
SCLK	J9	Serial interface clock input with an internal pulldown resistor of 20 kΩ. This pin is connected to both ADC and VCA. The designer should use 3.3-V logic.
SDATA	K9	Serial interface data input with an internal pulldown resistor of 20 kΩ. This pin is connected to both ADC and VCA. The designer should use 3.3-V logic.
SDOUT	M9	Serial interface data readout. High impedance when readout is disabled. This pin is connected to ADC only. The designer can use 1.8-V logic.
SEN	L9	Serial interface enable with an internal pullup resistor of 20 kΩ. Active low. This pin is connected to both ADC and VCA. The designer should use 3.3-V logic.
SPI_DIG_EN	M7	Serial interface enable for the digital demodulator memory space. SPI_DIG_EN pin is required to be set to 0 during SPI transactions to demodulator registers. Each transaction starts by setting SEN as 0 and terminates by setting it back to 1 (similar to other register transactions). Pull up internally through a 20-kΩ resistor. This pin is connected to both ADC and VCA. The designer should use 3.3-V logic.
TX_SYNC_IN	L7	System trig signal input. It indicates the start of signal transmission. Either 3.3-V or 1.8-V logic level can be used. Note: TX_SYNC signal must be synchronized with ADC CLK. Typically, pulse repetition frequency (PRF) signal can be used for TX_SYNC_IN.
VCNTLM	K4	Negative differential attenuation control pin
VCNTLP	K3	Positive differential attenuation control pin
VHIGH	K5	Bias voltage; bypass to ground with ≥1 μF
VREF_IN	M3	ADC 1.4-V reference input in the external reference mode; bypass to ground with 0.1 μF.
DNC	K7	Do not connect. Must leave floated
	L5	
	M5	
	M8	

## 7 Specifications

### 7.1 Absolute Maximum Ratings

 over operating free-air temperature (unless otherwise noted)<sup>(1)</sup>

		MIN	MAX	UNIT
Supply voltage	AVDD	−0.3	3.9	V
	AVDD_ADC	−0.3	2.2	
	AVDD_5V	−0.3	6	
	DVDD	−0.3	2.2	
	DVDD_LDO	−0.3	1.6	
Voltage between AVSS and LVSS		−0.3	0.3	V
Voltage at analog inputs and digital inputs		−0.3	min [3.6, AVDD + 0.3]	V
Peak solder temperature <sup>(2)</sup>			260	°C
Maximum junction temperature (T <sub>J</sub> ), any condition			105	°C
Operating temperature		0	85	°C
Storage temperature, T <sub>stg</sub>		−55	150	°C

(1) Stresses above those listed under *Absolute Maximum Ratings* may cause permanent damage to the device. These are stress ratings only and functional operation of the device at these or any other conditions beyond those indicated under *Recommended Operating Conditions* is not implied. Exposure to absolute maximum rated conditions for extended periods may degrade device reliability.

(2) Device complies with JSTD-020D.

## 7.2 ESD Ratings

			VALUE	UNIT
V <sub>(ESD)</sub>	Electrostatic discharge	Human body model (HBM), per ANSI/ESDA/JEDEC JS-001, all pins <sup>(1)</sup>	±1000	V
		Charged device model (CDM), per JEDEC specification JESD22-C101, all pins <sup>(2)</sup>	±250	

(1) JEDEC document JEP155 states that 500-V HBM allows safe manufacturing with a standard ESD control process.

(2) JEDEC document JEP157 states that 250-V CDM allows safe manufacturing with a standard ESD control process.

## 7.3 Recommended Operating Conditions

	MIN	MAX	UNIT
AVDD	3.15	3.6	V
AVDD_ADC	1.7	1.9	V
DVDD	1.7	1.9	V
DVDD_LDO1/2 (internally generated)	1.2	1.4	V
DVDD_LDO1/2 (external supplied)	1.4	1.5	V
AVDD_5V	4.75	5.5	V
Ambient temperature, T <sub>A</sub>	0	85	°C

## 7.4 Thermal Information

THERMAL METRIC <sup>(1)</sup>		AFE5809	
		BGA (NFBGA)	
		135 PINS	
			UNIT
R <sub>θJA</sub>	Junction-to-ambient thermal resistance	34.1	°C/W
R <sub>θJC(top)</sub>	Junction-to-case (top) thermal resistance	5	°C/W
R <sub>θJB</sub>	Junction-to-board thermal resistance	11.5	°C/W
Ψ <sub>JT</sub>	Junction-to-top characterization parameter	0.2	°C/W
Ψ <sub>JB</sub>	Junction-to-board characterization parameter	10.8	°C/W

(1) For more information about traditional and new thermal metrics, see the *Semiconductor and IC Package Thermal Metrics* application report, [SPRA953](#).

## 7.5 Electrical Characteristics

AVDD\_5V = 5 V, AVDD = 3.3 V, AVDD\_ADC = 1.8 V, DVDD = 1.8 V, AC-coupled with 0.1  $\mu$ F at INP and bypassed to ground with 15 nF at INM, No active termination, V<sub>CNTL</sub> = 0 V, f<sub>IN</sub> = 5 MHz, LNA = 18 dB, PGA = 24 dB, 14 bit, sample rate = 65 MSPS, LPF Filter = 15 MHz, low-noise mode, V<sub>OUT</sub> = –1 dBFS, Single-ended V<sub>CNTL</sub> mode, VCNTLM = GND, ADC configured in internal reference mode, internal 500- $\Omega$  CW feedback resistor, CMOS CW clocks, at ambient temperature, T<sub>A</sub> = 25°C, Digital demodulator is disabled unless otherwise noted. Min and max values are specified across full-temperature range with AVDD\_5 V = 5 V, AVDD = 3.3 V, AVDD\_ADC = 1.8 V, DVDD = 1.8 V.

PARAMETER		TEST CONDITIONS	MIN	TYP	MAX	UNIT
<b>TGC FULL SIGNAL CHANNEL (LNA + VCAT + LPF + ADC)</b>						
en (RTI)	Input voltage noise over LNA gain (low-noise mode)	Rs = 0 $\Omega$ , f = 2 MHz, LNA = 24, 18, 12 dB, PGA = 24 dB	0.76, 0.83, 1.16			nV/rHz
		Rs = 0 $\Omega$ , f = 2 MHz, LNA = 24, 18, 12 dB, PGA = 30 dB	0.75, 0.86, 1.12			
	Input voltage noise over LNA gain (low-power mode)	Rs = 0 $\Omega$ , f = 2 MHz, LNA = 24, 18, 12 dB, PGA = 24 dB	1.1, 1.2, 1.45			nV/rHz
		Rs = 0 $\Omega$ , f = 2 MHz, LNA = 24, 18, 12 dB, PGA = 30 dB	1.1, 1.2, 1.45			
en (RTI)	Input voltage noise over LNA gain (medium-power mode)	Rs = 0 $\Omega$ , f = 2 MHz, LNA = 24, 18, 12 dB, PGA = 24 dB	1, 1.05, 1.25			nV/rHz
		Rs = 0 $\Omega$ , f = 2 MHz, LNA = 24, 18, 12 dB, PGA = 30 dB	0.95, 1, 1.2			
en (RTI)	Input voltage noise at low frequency	f = 100 kHz, INM capacitor = 1 $\mu$ F, PGA integrator disabled	0.9			nV/rHz
	Input referred current noise	Low-noise mode/medium-power mode/low-power mode	2.7, 2.1, 2			pA/rHz
NF	Noise figure	Rs = 200 $\Omega$ , 200- $\Omega$ active termination, PGA = 24 dB, LNA = 12, 18, 24 dB	3.85, 2.4, 1.8			dB
		Rs = 100 $\Omega$ , 100- $\Omega$ active termination, PGA = 24 dB, LNA = 12, 18, 24 dB	5.3, 3.1, 2.3			
NF	Noise figure	Rs = 500 $\Omega$ , 1 k $\Omega$ , no termination, low-NF mode is enabled (Reg53[9] = 1)	0.94, 1.08			dB
NF	Noise figure	Rs = 50 $\Omega$ / 200 $\Omega$ , no termination, low-noise mode (Reg53[9] = 0)	2.35, 1.05			dB
V <sub>MAX</sub>	Maximum linear input voltage	LNA gain = 24, 18, 12 dB	250, 500, 1000			mVpp
V <sub>CLAMP</sub>	Clamp voltage	Reg52[10:9] = 0, LNA = 24, 18, 12 dB	350, 600, 1150			
	PGA gain	Low-noise mode	24, 30			dB
		Medium-power/low-power mode	24, 28.5			
	Total gain	LNA = 24 dB, PGA = 30 dB, low-noise mode	54			dB
		LNA = 24 dB, PGA = 30 dB, medium-power mode	52.5			
		LNA = 24 dB, PGA = 30 dB, low-power mode	52.5			
	Ch-CH noise correlation factor without signal <sup>(1)</sup>	Summing of 8 channels	0			
	Ch-CH noise correlation factor with signal <sup>(1)</sup>	Full band (V <sub>CNTL</sub> = 0, 0.8)	0.15, 0.17			
		1-MHz band over carrier (V <sub>CNTL</sub> = 0, 0.8)	0.18, 0.75			
	Signal-to-noise ratio (SNR)	V <sub>CNTL</sub> = 0.6 V (22-dB total channel gain)	68	70		dBFS
		V <sub>CNTL</sub> = 0, LNA = 18 dB, PGA = 24 dB	59.3	63		
		V <sub>CNTL</sub> = 0, LNA = 24 dB, PGA = 24 dB		58		
	Narrow-band SNR	SNR over 2-MHz band around carrier at V <sub>CNTL</sub> = 0.6 V (22-dB total gain)	75	77		dBFS
	Input common-mode voltage	At INP and INM pins	2.4			V
	Input resistance		8			k $\Omega$
		Preset active termination enabled	50,100,200,400			
	Input capacitance		20			pF
	Input control voltage	V <sub>CNTLP</sub> – V <sub>CNTLM</sub>	0		1.5	V
	Common-mode voltage	V <sub>CNTLP</sub> and V <sub>CNTLM</sub>	0.75			V
	Gain range		–40			dB
	Gain slope	V <sub>CNTL</sub> = 0.1 to 1.1 V	35			dB/V
	Input resistance	Between V <sub>CNTLP</sub> and V <sub>CNTLM</sub>	200			k $\Omega$
	Input capacitance	Between V <sub>CNTLP</sub> and V <sub>CNTLM</sub>	1			pF
	TGC response time	V <sub>CNTL</sub> = 0- to 1.5-V step function	1.5			$\mu$ s
	Third-order LPF		10, 15, 20, 30			MHz
	Settling time for change in LNA gain		14			$\mu$ s
	Settling time for change in active termination setting		1			$\mu$ s

- (1) Noise correlation factor is defined as N<sub>c</sub> / (N<sub>u</sub> + N<sub>c</sub>), where N<sub>c</sub> is the correlated noise power in single channel; and N<sub>u</sub> is the uncorrelated noise power in single channel. Its measurement follows the below equation, in which the SNR of single-channel signal and the SNR of summed eight-channel signal are measured.

$$\frac{N_C}{N_u + N_C} = \frac{10^{\frac{8CH\_SNR}{20}}}{10^{\frac{1CH\_SNR}{20}}} \times \frac{1}{56} - \frac{1}{7}$$

## Electrical Characteristics (continued)

AVDD\_5V = 5 V, AVDD = 3.3 V, AVDD\_ADC = 1.8 V, DVDD = 1.8 V, AC-coupled with 0.1  $\mu$ F at INP and bypassed to ground with 15 nF at INM, No active termination, V<sub>CNTL</sub> = 0 V, f<sub>IN</sub> = 5 MHz, LNA = 18 dB, PGA = 24 dB, 14 bit, sample rate = 65 MSPS, LPF Filter = 15 MHz, low-noise mode, V<sub>OUT</sub> = -1 dBFS, Single-ended V<sub>CNTL</sub> mode, VCNTLM = GND, ADC configured in internal reference mode, internal 500- $\Omega$  CW feedback resistor, CMOS CW clocks, at ambient temperature, T<sub>A</sub> = 25°C, Digital demodulator is disabled unless otherwise noted. Min and max values are specified across full-temperature range with AVDD\_5 V = 5 V, AVDD = 3.3 V, AVDD\_ADC = 1.8 V, DVDD = 1.8 V.

PARAMETER		TEST CONDITIONS	MIN	TYP	MAX	UNIT
<b>AC ACCURACY</b>						
	LPF bandwidth tolerance			±5%		
	CH-CH group delay variation	2 to 15 MHz		2		ns
	CH-CH phase variation	15-MHz signal		11		°
	Gain matching	0 V < V <sub>CNTL</sub> < 0.1 V (Dev-to-Dev)		±0.5		dB
		0.1 V < V <sub>CNTL</sub> < 1.1 V (Dev-to-Dev), T <sub>A</sub> = 25°C	-1	±0.5	1	
		1.1 V < V <sub>CNTL</sub> < 1.5 V (Dev-to-Dev)		±0.5		
		0.1 V < V <sub>CNTL</sub> < 1.1 V (Dev-to-Dev), T <sub>A</sub> = 0°C and 85°C	-1.1		1.1	
	Gain matching	Channel-to-channel		±0.25		dB
	Output offset	V <sub>CNTL</sub> = 0, PGA = 30 dB, LNA = 24 dB	-75		75	LSB
<b>AC PERFORMANCE</b>						
HD2	Second-harmonic distortion	F <sub>IN</sub> = 2 MHz; V <sub>OUT</sub> = -1 dBFS		-60		dBc
		F <sub>IN</sub> = 5 MHz; V <sub>OUT</sub> = -1 dBFS		-60		
		F <sub>IN</sub> = 5 MHz; V <sub>IN</sub> = 500 mV <sub>PP</sub> , V <sub>OUT</sub> = -1 dBFS, LNA = 18 dB, V <sub>CNTL</sub> = 0.88 V		-55		
		F <sub>IN</sub> = 5 MHz; V <sub>IN</sub> = 250 mV <sub>PP</sub> , V <sub>OUT</sub> = -1 dBFS, LNA = 24 dB, V <sub>CNTL</sub> = 0.88 V		-55		
HD3	Third-harmonic distortion	F <sub>IN</sub> = 2 MHz; V <sub>OUT</sub> = -1 dBFS		-55		dBc
		F <sub>IN</sub> = 5 MHz; V <sub>OUT</sub> = -1 dBFS		-55		
		F <sub>IN</sub> = 5 MHz; V <sub>IN</sub> = 500 mV <sub>PP</sub> , V <sub>OUT</sub> = -1 dBFS, LNA = 18 dB, V <sub>CNTL</sub> = 0.88 V		-55		
		F <sub>IN</sub> = 5 MHz; V <sub>IN</sub> = 250 mV <sub>PP</sub> , V <sub>OUT</sub> = -1 dBFS, LNA = 24 dB, V <sub>CNTL</sub> = 0.88 V		-55		
THD	Total harmonic distortion	F <sub>IN</sub> = 2 MHz; V <sub>OUT</sub> = -1 dBFS		-55		dBc
		F <sub>IN</sub> = 5 MHz; V <sub>OUT</sub> = -1 dBFS		-55		
IMD3	Intermodulation distortion	f <sub>1</sub> = 5 MHz at -1 dBFS, f <sub>2</sub> = 5.01 MHz at -27 dBFS		-60		dBc
XTALK	Cross-talk	F <sub>IN</sub> = 5 MHz; V <sub>OUT</sub> = -1 dBFS		-65		dB
	Phase noise	kHz off 5 MHz (V <sub>CNTL</sub> = 0 V)		-132		dBc/Hz
<b>LNA</b>						
	Input referred voltage noise	R <sub>s</sub> = 0 $\Omega$ , f = 2 MHz, R <sub>in</sub> = High Z, Gain = 24, 18, 12 dB		0.63, 0.70, 0.9		nV/rtHz
	High-pass filter (HPF)	-3 dB cut-off frequency		50, 100, 150, 200		kHz
	LNA linear output			4		V <sub>pp</sub>
<b>VCAT+ PGA</b>						
	VCAT input noise	0-dB, -40-dB attenuation		2, 10.5		nV/rtHz
	PGA input noise	24 dB, 30 dB		1.75		nV/rtHz
	-3 dB HPF cut-off frequency			80		kHz

## Electrical Characteristics (continued)

AVDD\_5V = 5 V, AVDD = 3.3 V, AVDD\_ADC = 1.8 V, DVDD = 1.8 V, AC-coupled with 0.1  $\mu$ F at INP and bypassed to ground with 15 nF at INM, No active termination,  $V_{CNTL} = 0$  V,  $f_{IN} = 5$  MHz, LNA = 18 dB, PGA = 24 dB, 14 bit, sample rate = 65 MSPS, LPF Filter = 15 MHz, low-noise mode,  $V_{OUT} = -1$  dBFS, Single-ended  $V_{CNTL}$  mode,  $V_{CNTLM} = GND$ , ADC configured in internal reference mode, internal 500- $\Omega$  CW feedback resistor, CMOS CW clocks, at ambient temperature,  $T_A = 25^\circ\text{C}$ , Digital demodulator is disabled unless otherwise noted. Min and max values are specified across full-temperature range with AVDD\_5 V = 5 V, AVDD = 3.3 V, AVDD\_ADC = 1.8 V, DVDD = 1.8 V.

PARAMETER		TEST CONDITIONS	MIN	TYP	MAX	UNIT
<b>CW DOPPLER</b>						
en (RTI)	Input voltage noise (CW)	1-channel mixer, LNA = 24 dB, 500- $\Omega$ feedback resistor		0.8		nV/rHz
		8-channel mixer, LNA = 24 dB, 62.5- $\Omega$ feedback resistor		0.33		
en (RTO)	Output voltage noise (CW)	1-channel mixer, LNA = 24 dB, 500- $\Omega$ feedback resistor		12		nV/rHz
		8-channel mixer, LNA = 24 dB, 62.5- $\Omega$ feedback resistor		5		
en (RTI)	Input voltage noise (CW)	1-channel mixer, LNA = 18 dB, 500- $\Omega$ feedback resistor		1.1		nV/rHz
		8-channel mixer, LNA = 18 dB, 62.5- $\Omega$ feedback resistor		0.5		
en (RTO)	Output voltage noise (CW)	1-channel mixer, LNA = 18 dB, 500- $\Omega$ feedback resistor		8.1		nV/rHz
		8-channel mixer, LNA = 18 dB, 62.5- $\Omega$ feedback resistor		4		
NF	Noise figure	$R_S = 100 \Omega$ , $R_{IN} = \text{High Z}$ , $F_{IN} = 2$ MHz (LNA, I/Q mixer and summing amplifier/filter)		1.8		dB
$f_{CW}$	CW operation range <sup>(2)</sup>	CW signal carrier frequency		8		MHz
	CW clock frequency	1x CLK (16x mode)			8	MHz
		16x CLK(16x mode)			128	
		4x CLK(4x mode)			32	
	AC coupled LVDS clock amplitude	CLKM_16X-CLKP_16X; CLKM_1X-CLKP_1X		0.7		Vpp
	AC coupled LVPECL clock amplitude			1.6		
	CLK duty cycle	1x and 16x CLKs	35%		65%	
	Common-mode voltage	Internal provided		2.5		V
$V_{CMOS}$	CMOS input clock amplitude		4		5	V
	CW mixer conversion loss			4		dB
	CW mixer phase noise	1 kHz off 2-MHz carrier		156		dBc/Hz
DR	Input dynamic range	$F_{IN} = 2$ MHz, LNA = 24/18/12 dB	160, 164, 165			dBFS/Hz
IMD3	Intermodulation distortion	$f_1 = 5$ MHz, $f_2 = 5.01$ MHz, both tones at $-8.5$ -dBm amplitude, 8 channels summed up in-phase, CW feedback resistor = 87 $\Omega$		-50		dBc
		$f_1 = 5$ MHz, $f_2 = 5.01$ MHz, both tones at $-8.5$ -dBm amplitude, single-channel case, CW feedback resistor = 500 $\Omega$		-60		dBc
	I/Q channel gain matching	16x mode		$\pm 0.04$		dB
	I/Q channel phase matching	16x mode		$\pm 0.1$		$^\circ$
	I/Q channel gain matching	4x mode		$\pm 0.04$		dB
	I/Q channel phase matching	4x mode		$\pm 0.1$		$^\circ$
	Image rejection ratio	$F_{IN} = 2.01$ MHz, 300-mV input amplitude, CW clock frequency = 2 MHz		-50		dBc

- (2) In the 16x operation mode, the CW operation range is limited to 8 MHz due to the 16x CLK. The maximum clock frequency for the 16x CLK is 128 MHz. In the 8x, 4x, and 1x modes, higher CW signal frequencies up to 15 MHz can be supported with small degradation in performance, see [CW Clock Selection](#).

## Electrical Characteristics (continued)

AVDD\_5V = 5 V, AVDD = 3.3 V, AVDD\_ADC = 1.8 V, DVDD = 1.8 V, AC-coupled with 0.1  $\mu$ F at INP and bypassed to ground with 15 nF at INM, No active termination,  $V_{CNTL} = 0$  V,  $f_{IN} = 5$  MHz, LNA = 18 dB, PGA = 24 dB, 14 bit, sample rate = 65 MSPS, LPF Filter = 15 MHz, low-noise mode,  $V_{OUT} = -1$  dBFS, Single-ended  $V_{CNTL}$  mode,  $V_{CNTLM} = GND$ , ADC configured in internal reference mode, internal 500- $\Omega$  CW feedback resistor, CMOS CW clocks, at ambient temperature,  $T_A = 25^\circ\text{C}$ , Digital demodulator is disabled unless otherwise noted. Min and max values are specified across full-temperature range with AVDD\_5 V = 5 V, AVDD = 3.3 V, AVDD\_ADC = 1.8 V, DVDD = 1.8 V.

PARAMETER		TEST CONDITIONS	MIN	TYP	MAX	UNIT
<b>CW SUMMING AMPLIFIER</b>						
$V_{CMO}$	Common-mode voltage	Summing amplifier inputs and outputs		1.5		V
	Summing amplifier output			4		V <sub>pp</sub>
	Input referred voltage noise	100 Hz		2		nV/rHz
		1 kHz		1.2		nV/rHz
		2 kHz to 100 MHz		1		nV/rHz
	Input referred current noise			2.5		pA/rHz
	Unit gain bandwidth			200		MHz
	Max output current	Linear operation range		20		mApp
<b>ADC SPECIFICATIONS</b>						
	Sample rate		10		65	MSPS
SNR	Signal-to-noise ratio	Idle channel SNR of ADC 14b		77		dBFS
	Internal reference mode	REFP		1.5		V
		REFM		0.5		V
	External reference mode	VREF_IN voltage		1.4		V
		VREF_IN current		50		$\mu$ A
	ADC input full-scale range			2		V <sub>pp</sub>
	LVDS rate	65 MSPS at 14 bit		910		Mbps
<b>POWER DISSIPATION</b>						
	AVDD voltage		3.15	3.3	3.6	V
	AVDD_ADC voltage		1.7	1.8	1.9	V
	AVDD_5V voltage		4.75	5	5.5	V
	DVDD voltage		1.7	1.8	1.9	V
	Total power dissipation per channel	TGC low-noise mode, 65 MSPS		158	190	mW/CH
		TGC low-noise mode, 40 MSPS		145		
		TGC medium-power mode, 40 MSPS		114		
		TGC low-power mode, 40 MSPS		101.5		
	AVDD (3.3-V) current	TGC low-noise mode, no signal		202	240	mA
		TGC medium-power mode, no signal		126		
		TGC low-power mode, no signal		99		
		CW-mode, no signal		147	170	
		TGC low-noise mode, 500 mV <sub>pp</sub> Input, 1% duty cycle		210		
		TGC medium-power mode, 500 mV <sub>pp</sub> Input, 1% duty cycle		133		
		TGC low power, 500 mV <sub>pp</sub> Input, 1% duty cycle		105		
		CW-mode, 500 mV <sub>pp</sub> Input		375		
	AVDD_5V current	TGC mode no signal		25.5	35	mA
		CW mode no signal, 16x clock = 32 MHz		32		
		TGC mode, 500-mV <sub>pp</sub> Input, 1% duty cycle		26		
		CW-mode, 500-mV <sub>pp</sub> input		42.5		
	VCA power dissipation	TGC low-noise mode, no signal		99	121	mW/CH
		TGC medium-power mode, no signal		68		
		TGC low-power mode, no signal		55.5		
		TGC low-noise mode, 500-mV <sub>pp</sub> input, 1% duty cycle		102.5		
		TGC medium-power mode, 500-mV <sub>pp</sub> Input, 1% duty cycle		71		
	CW power dissipation	No signal, ADC shutdown CW mode no signal, 16x clock = 32 MHz		80		mW/CH
		500-mV <sub>pp</sub> input, ADC shutdown, 16x clock = 32 MHz		173		
	AVDD_ADC (1.8-V) current	65MSPS		187	205	mA
	DVDD (1.8-V) current	65 MSPS		77	110	mA

## Electrical Characteristics (continued)

AVDD\_5V = 5 V, AVDD = 3.3 V, AVDD\_ADC = 1.8 V, DVDD = 1.8 V, AC-coupled with 0.1  $\mu$ F at INP and bypassed to ground with 15 nF at INM, No active termination,  $V_{CNTL} = 0$  V,  $f_{IN} = 5$  MHz, LNA = 18 dB, PGA = 24 dB, 14 bit, sample rate = 65 MSPS, LPF Filter = 15 MHz, low-noise mode,  $V_{OUT} = -1$  dBFS, Single-ended  $V_{CNTL}$  mode,  $V_{CNTLM} = GND$ , ADC configured in internal reference mode, internal 500- $\Omega$  CW feedback resistor, CMOS CW clocks, at ambient temperature,  $T_A = 25^\circ\text{C}$ , Digital demodulator is disabled unless otherwise noted. Min and max values are specified across full-temperature range with AVDD\_5 V = 5 V, AVDD = 3.3 V, AVDD\_ADC = 1.8 V, DVDD = 1.8 V.

PARAMETER	TEST CONDITIONS	MIN	TYP	MAX	UNIT
ADC power dissipation/CH	65 MSPS		59	69	mW/CH
	50 MSPS		51		
	40 MSPS		46		
	20 MSPS		35		
Power dissipation in power-down mode	PDN_VCA = High, PDN_ADC = High		25		mW/CH
	Complete power-down PDN_Global = High		0.6		
Power-down response time	Time taken to enter power down		1		$\mu$ s
Power-up response time	VCA power down		2 $\mu$ s + 1% of PDN time		$\mu$ s
	ADC power down		1		
	Complete power down		2.5		ms
Power supply modulation ratio, AVDD and AVDD_5V	$F_{IN} = 5$ MHz, at 50 mV <sub>pp</sub> noise at 1 kHz on supply <sup>(3)</sup>		-65		dBc
	$F_{IN} = 5$ MHz, at 50 mV <sub>pp</sub> noise at 50 kHz on supply <sup>(3)</sup>		-65		
Power supply rejection ratio	$f = 10$ kHz, $V_{CNTL} = 0$ V (high gain), AVDD		-40		dBc
	$f = 10$ kHz, $V_{CNTL} = 0$ V (high gain), AVDD_5 V		-55		dBc
	$f = 10$ kHz, $V_{CNTL} = 1$ V (low gain), AVDD		-50		dBc

(3) PSMR specification is with respect to carrier signal amplitude.

## 7.6 Digital Demodulator Electrical Characteristics

AVDD\_5 V = 5 V, AVDD = 3.3 V, AVDD\_ADC = 1.8 V, DVDD = 1.8 V, DVDD\_LDO = 1.4 V (internal generated), 14 bit/65 MSPS, 4x decimation factor, at ambient temperature  $T_A = 25^\circ\text{C}$ , unless otherwise noted.

PARAMETER	TEST CONDITIONS	MIN	TYP	MAX	UNIT
Additional power consumption on DVDD (1.8 V)	65 MSPS, 4x decimation factor		90		mW/CH
Additional power consumption on DVDD (1.8 V)	40 MSPS, 4x decimation factor		61		mW/CH
Additional power consumption on DVDD (1.8 V)	65 MSPS, 32x decimation factor, half LVDS pairs are powered down		77		mW/CH
Additional power consumption on DVDD (1.8 V)	40 MSPS, 32x decimation factor, half LVDS pairs are powered down		55		mW/CH
$V_{IH}$	Logic high input voltage, TX_SYNC pin	Support 1.8-V and 3.3-V CMOS logic	1.3	3.3	V
$V_{IL}$	Logic low input voltage, TX_SYNC pin	Support 1.8-V and 3.3-V CMOS logic	0	0.3	V
$I_{IH}$	Logic high input current, TX_SYNC pin	$V_{HIGH} = 1.8$ V	11		$\mu$ A
$I_{IL}$	Logic low input current, TX_SYNC pin	$V_{LOW} = 0$ V	< 0.1		$\mu$ A
$V_{IH}$	Logic high input voltage, LDO_EN pin		1.7	3.3	V
$V_{IL}$	Logic low input voltage, LDO_EN pin		0	0.3	V
$I_{IH}$	Logic high input current, LDO_EN pin	$V_{HIGH} = 1.8$ V	11		$\mu$ A
$I_{IL}$	Logic low input current, LDO_EN pin	$V_{LOW} = 0$ V	< 0.1		$\mu$ A

## 7.7 Digital Characteristics

Typical values are at 25°C, AVDD = 3.3 V, AVDD\_5 = 5 V and AVDD\_ADC = 1.8 V, DVDD = 1.8 V unless otherwise noted. Minimum and maximum values are across the full temperature range: T<sub>MIN</sub> = 0°C to T<sub>MAX</sub> = 85°C.

PARAMETER		TEST CONDITIONS	MIN	TYP	MAX	UNIT <sup>(1)</sup>
<b>DIGITAL INPUTS/OUTPUTS</b>						
V <sub>IH</sub>	Logic high input voltage		2		3.3	V
V <sub>IL</sub>	Logic low input voltage		0		0.3	V
	Logic high input current			200		μA
	Logic low input current			200		μA
	Input capacitance			5		pF
V <sub>OH</sub>	Logic high output voltage	SDOUT pin		DVDD		V
V <sub>OL</sub>	Logic low output voltage	SDOUT pin		0		V
<b>LVDS OUTPUTS</b>						
	Output differential voltage	With 100-Ω external differential termination		400		mV
	Output offset voltage	Common-mode voltage		1100		mV
	FCLKP and FCLKM	1× clock rate	10		65	MHz
	DCLKP and DCLKM	7× clock rate	70		455	MHz
		6× clock rate	60		390	MHz
t <sub>SU</sub>	Data setup time <sup>(2)</sup>			350		ps
t <sub>H</sub>	Data hold time <sup>(2)</sup>			350		ps
<b>ADC INPUT CLOCK</b>						
	Clock frequency		10		65	MSPS
	Clock duty cycle		45%	50%	55%	
	Clock input amplitude, differential (V <sub>CLKP_ADC</sub> – V <sub>CLKM_ADC</sub> )	Sine-wave, AC-coupled	0.5			V <sub>pp</sub>
		LVPECL, AC-coupled		1.6		V <sub>pp</sub>
		LVDS, AC-coupled			0.7	
	Common-mode voltage	Biased internally		1		V
	Clock input amplitude V <sub>CLKP_ADC</sub> (single-ended)	CMOS clock		1.8		V <sub>pp</sub>

- (1) The DC specifications refer to the condition where the LVDS outputs are not switching, but are permanently at a valid logic level 0 or 1 with 100-Ω external termination.
- (2) Setup and hold time specifications take into account the effect of jitter on the output data and clock. These specifications also assume that the data and clock paths are perfectly matched within the receiver. Any mismatch in these paths within the receiver would appear as reduced timing margins

## 7.8 Switching Characteristics

AVDD\_5 V = 5 V, AVDD = 3.3 V, AVDD\_ADC = 1.8 V, DVDD = 1.8 V. Typical values are at 25°C, Differential clock, C<sub>LOAD</sub> = 5 pF, R<sub>LOAD</sub> = 100 Ω, 14 bit, sample rate = 65 MSPS, digital demodulator is disabled, unless otherwise noted. Minimum and maximum values are across the full temperature range T<sub>MIN</sub> = 0°C to T<sub>MAX</sub> = 85°C.<sup>(1)</sup>

PARAMETER		TEST CONDITIONS	MIN	TYP	MAX	UNIT
t <sub>a</sub>	Aperture delay	The delay in time between the rising edge of the input sampling clock and the actual time at which the sampling occurs.	0.7	3		ns
	Aperture delay matching	Across channels within the same device		±150		ps
t <sub>j</sub>	Aperture jitter			450		Fs rms
	ADC latency	Default, after reset, or / 0 x 2 [12] = 1, LOW_LATENCY = 1		11/8		Input clock cycles
t <sub>delay</sub>	Data and frame clock delay	Input clock rising edge (zero cross) to frame clock rising edge (zero cross) minus 3/7 of the input clock period (T)	3	5.4	7	ns
Δt <sub>delay</sub>	Delay variation	At fixed supply and 20°C T difference; device to device	-1		1	ns
t <sub>RISE</sub>	Data rise time	Rise time measured from -100 to 100 mV		0.14		ns
t <sub>FALL</sub>	Data fall time	Fall time measured from 100 to -100 mV 10 MHz < f <sub>CLKIN</sub> < 65 MHz		0.15		
t <sub>FCLKRISE</sub>	Frame clock rise time	Rise time measured from -100 to 100 mV		0.14		ns
t <sub>FCLKFALL</sub>	Frame clock fall time	Fall time measured from 100 to -100 mV 10 MHz < f <sub>CLKIN</sub> < 65 MHz		0.15		
	Frame clock duty cycle	Zero crossing of the rising edge to zero crossing of the falling edge	48%	50%	52%	
t <sub>DCLKRISE</sub>	Bit clock rise time	Rise time measured from -100 to 100 mV		0.13		ns
t <sub>DCLKFALL</sub>	Bit clock fall time	Fall time measured from 100 to -100 mV 10 MHz < f <sub>CLKIN</sub> < 65 MHz		0.12		
	Bit clock duty cycle	Zero crossing of the rising edge to zero crossing of the falling edge 10 MHz < f <sub>CLKIN</sub> < 65 MHz	46%		54%	

(1) Timing parameters are ensured by design and characterization; not production tested.

## 7.9 SPI Switching Characteristics

Minimum values across full temperature range T<sub>MIN</sub> = 0°C to T<sub>MAX</sub> = 85°C, AVDD\_5V = 5 V, AVDD = 3.3 V, AVDD\_ADC = 1.8 V, DVDD = 1.8 V

PARAMETER		MIN	TYP	MAX	UNIT
t <sub>1</sub>	SCLK period	50			ns
t <sub>2</sub>	SCLK high time	20			ns
t <sub>3</sub>	SCLK low time	20			ns
t <sub>4</sub>	Data setup time	5			ns
t <sub>5</sub>	Data hold time	5			ns
t <sub>6</sub>	$\overline{SEN}$ fall to SCLK rise	8			ns
t <sub>7</sub>	Time between last SCLK rising edge to $\overline{SEN}$ rising edge	8			ns
t <sub>8</sub>	SDOUT delay	12	20	28	ns

## 7.10 Output Interface Timing Requirements (14-bit)

$f_{CLKIN}$ , Input Clock Frequency <sup>(1)(2)(3)</sup>	Setup Time ( $t_{su}$ ), ns			Hold Time ( $t_h$ ), ns			$t_{PROG} = (3/7) \times T + t_{delay}$ , ns		
	Data Valid to Bit Clock Zero-Crossing			Bit Clock Zero-Crossing to Data Invalid			Input Clock Zero-Cross (Rising Edge) to Frame Clock Zero-Cross (Rising Edge)		
MHz	MIN	TYP	MAX	MIN	TYP	MAX	MIN	TYP	MAX
65	0.24	0.37		0.24	0.38		11	12	12.5
50	0.41	0.54		0.46	0.57		13	13.9	14.4
40	0.55	0.70		0.61	0.73		15	16	16.7
30	0.87	1.10		0.94	1.1		18.5	19.5	20.1
20	1.30	1.56		1.46	1.6		25.7	26.7	27.3

- (1) FCLK timing is the same as for the output data lines. It has the same relation to DCLK as the data pins. Setup and hold are the same for the data and frame clock.
- (2) Data valid is logic high = 100 mV and logic low = -100 mV
- (3) Timing parameters are ensured by design and characterization; not production tested.

### NOTE

The data from [Output Interface Timing Requirements \(14-bit\)](#) can be applied to 12-bit or 16-bit LVDS rates as well. For example, the maximum LVDS output rate at 65 MHz and 14-bit is equal to 910 MSPS, which is approximately equivalent to the rate at 56 MHz and 16 bits.

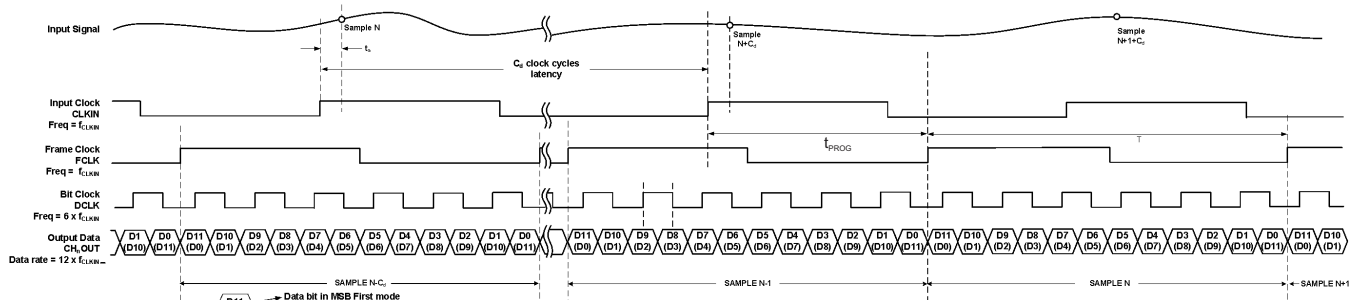

12-Bit 6x Serialization Mode

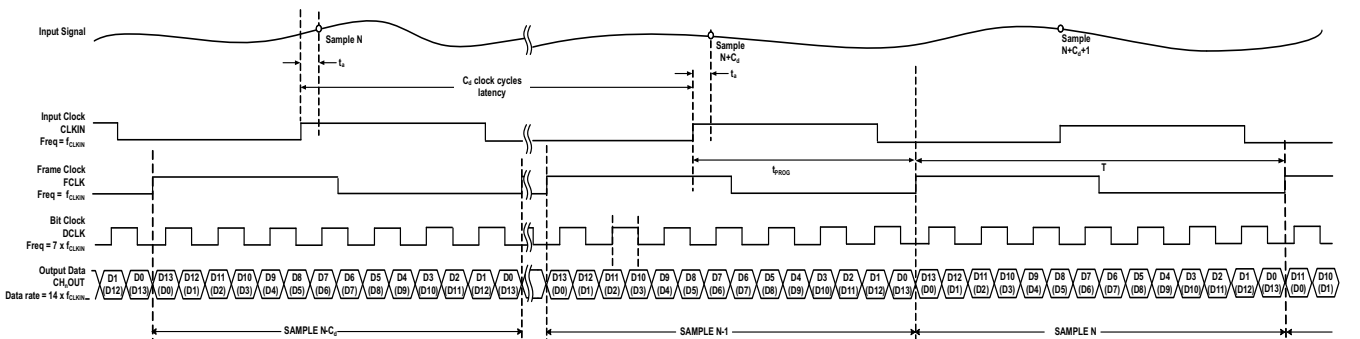

14-Bit 7x Serialization Mode

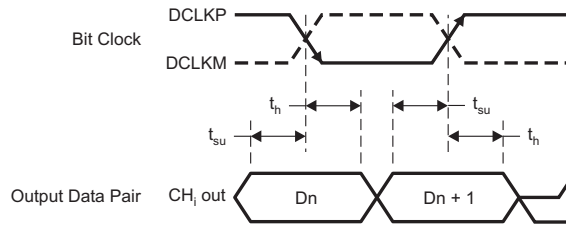

LVDS Setup and Hold Timing

Figure 1. LVDS Timing Diagrams

T0434-01

### 7.11 Typical Characteristics

AVDD\_5 V = 5 V, AVDD = 3.3 V, AVDD\_ADC = 1.8 V, DVDD = 1.8 V, AC-coupled with 0.1- $\mu$ F capacitors at INP and 15-nF capacitors at INM, No active termination, V<sub>CNTL</sub> = 0 V, F<sub>IN</sub> = 5 MHz, LNA = 18 dB, PGA = 24 dB, 14 bit, sample rate = 65 MSPS, LPF filter = 15 MHz, low-noise mode, Single-ended V<sub>CNTLM</sub> mode, V<sub>CNTLM</sub> = GND, ADC is configured in internal reference mode, V<sub>OUT</sub> = -1 dBFS, 500- $\Omega$  CW feedback resistor, CMOS 16x clock, digital demodulator is disabled, at ambient temperature T<sub>A</sub> = 25°C, unless otherwise noted.

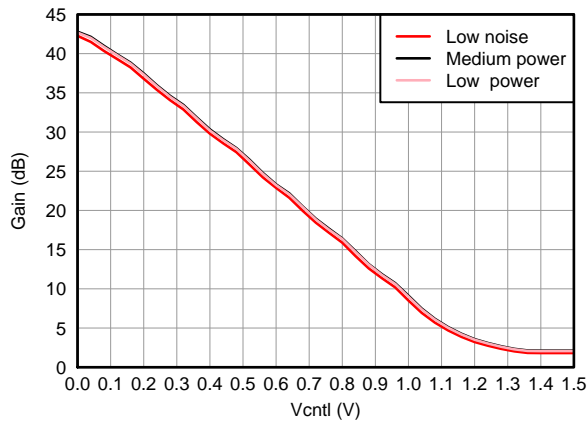

Figure 2. Gain vs V<sub>CNTL</sub>, LNA = 18 dB and PGA = 24 dB

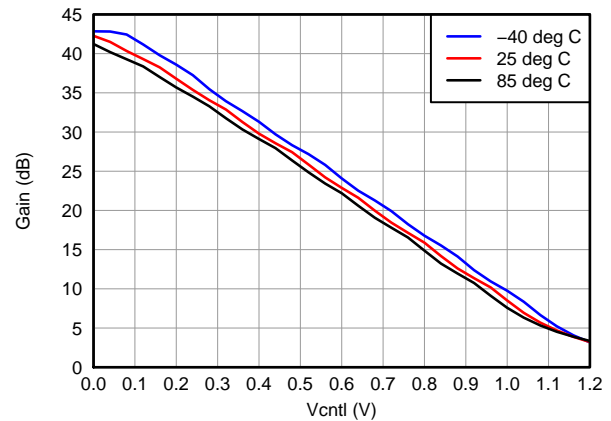

Figure 3. Gain Variation vs Temperature, LNA = 18 dB and PGA = 24 dB

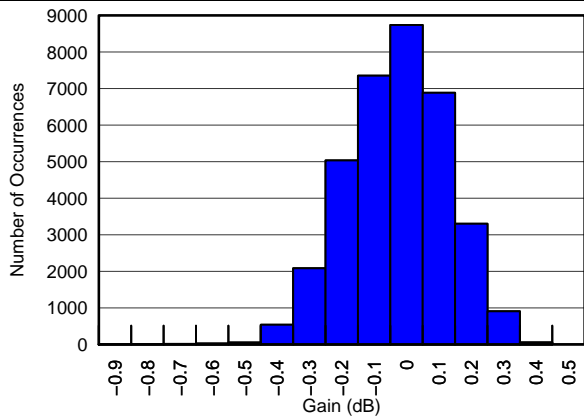

Figure 4. Gain Matching Histogram, V<sub>CNTL</sub> = 0.3 V (34951 Channels)

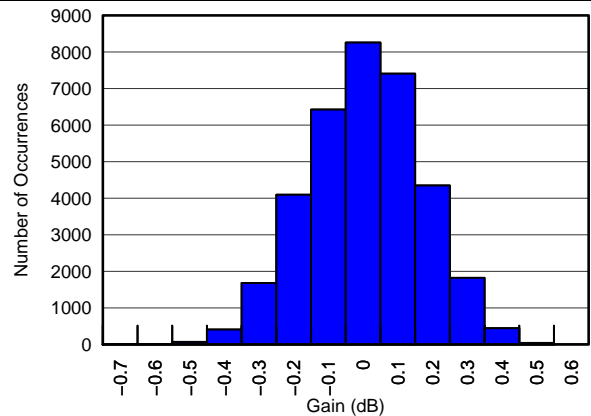

Figure 5. Gain Matching Histogram, V<sub>CNTL</sub> = 0.6 V (34951 Channels)

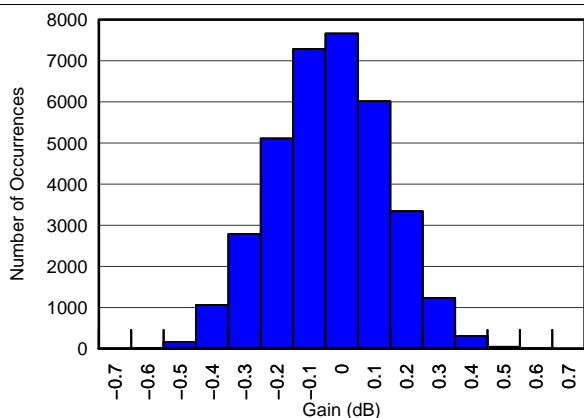

Figure 6. Gain Matching Histogram, V<sub>CNTL</sub> = 0.9 V (34951 Channels)

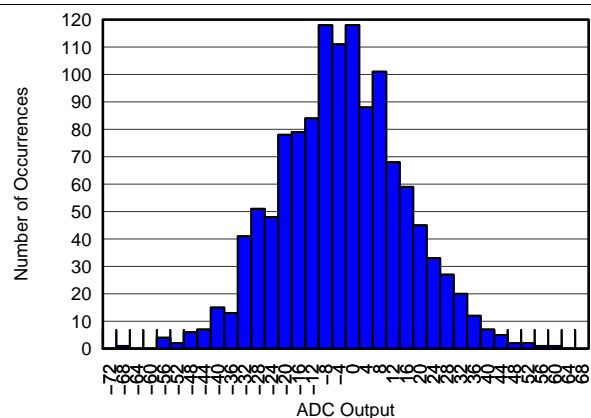

Figure 7. Output Offset Histogram, V<sub>CNTL</sub> = 0 V (1247 Channels)

### Typical Characteristics (continued)

AVDD\_5 V = 5 V, AVDD = 3.3 V, AVDD\_ADC = 1.8 V, DVDD = 1.8 V, AC-coupled with 0.1- $\mu$ F capacitors at INP and 15-nF capacitors at INM, No active termination,  $V_{CNTL} = 0$  V,  $F_{IN} = 5$  MHz, LNA = 18 dB, PGA = 24 dB, 14 bit, sample rate = 65 MSPS, LPF filter = 15 MHz, low-noise mode, Single-ended  $V_{CNTL}$  mode,  $V_{CNTLM} = GND$ , ADC is configured in internal reference mode,  $V_{OUT} = -1$  dBFS, 500- $\Omega$  CW feedback resistor, CMOS 16x clock, digital demodulator is disabled, at ambient temperature  $T_A = 25^\circ\text{C}$ , unless otherwise noted.

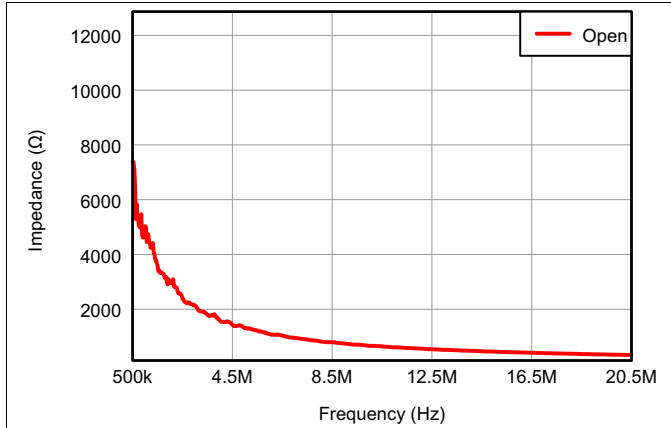

Figure 8. Input Impedance Without Active Termination (Magnitude)

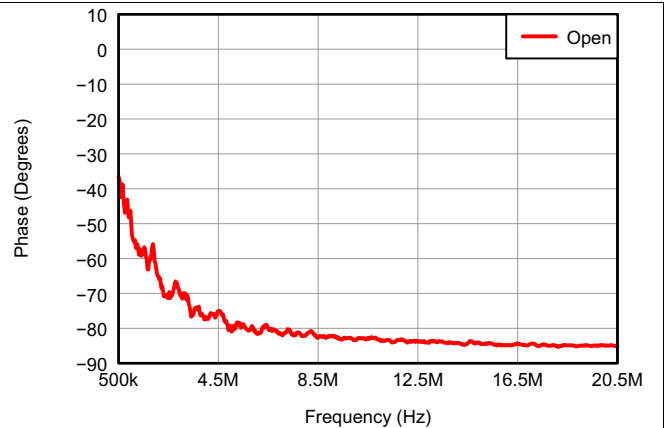

Figure 9. Input Impedance Without Active Termination (Phase)

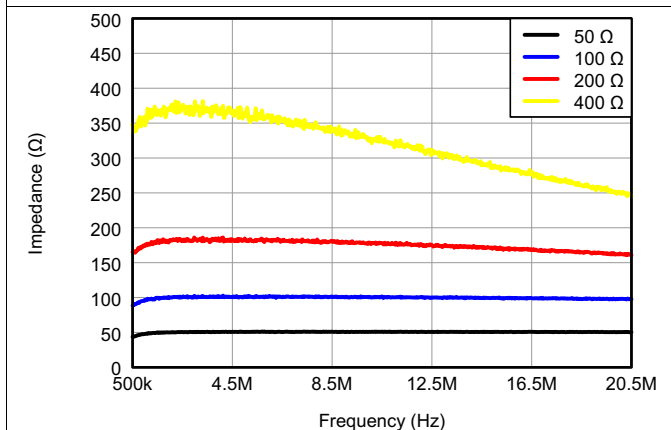

Figure 10. Input Impedance With Active Termination (Magnitude)

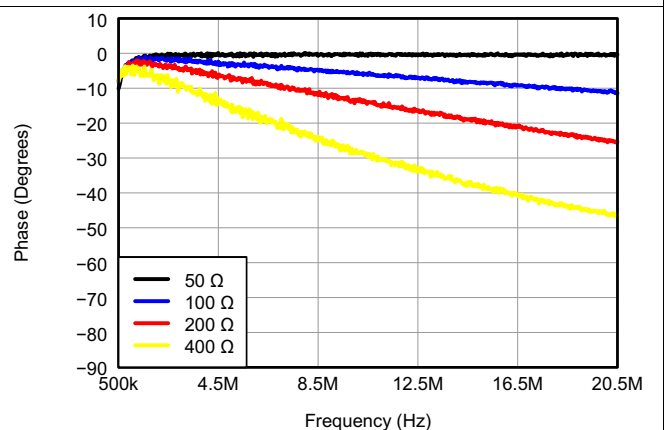

Figure 11. Input Impedance With Active Termination (Phase)

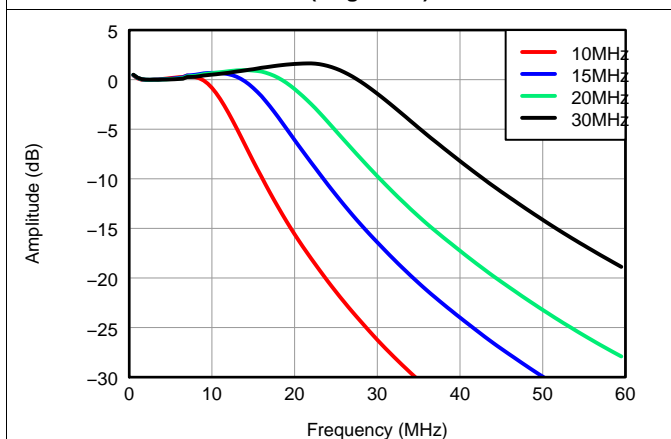

Figure 12. LPF Response

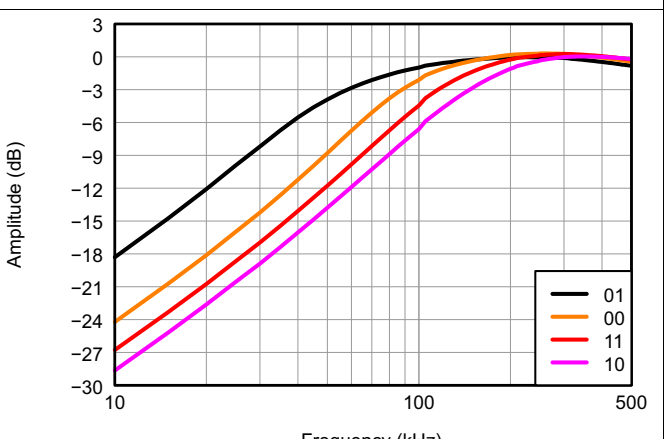

Figure 13. LNA HPF Response vs Reg59[3:2]

Typical Characteristics (continued)

AVDD\_5 V = 5 V, AVDD = 3.3 V, AVDD\_ADC = 1.8 V, DVDD = 1.8 V, AC-coupled with 0.1- $\mu$ F capacitors at INP and 15-nF capacitors at INM, No active termination, V<sub>CNTL</sub> = 0 V, F<sub>IN</sub> = 5 MHz, LNA = 18 dB, PGA = 24 dB, 14 bit, sample rate = 65 MSPS, LPF filter = 15 MHz, low-noise mode, Single-ended V<sub>CNTL</sub> mode, V<sub>CNTLM</sub> = GND, ADC is configured in internal reference mode, V<sub>OUT</sub> = -1 dBFS, 500- $\Omega$  CW feedback resistor, CMOS 16x clock, digital demodulator is disabled, at ambient temperature T<sub>A</sub> = 25°C, unless otherwise noted.

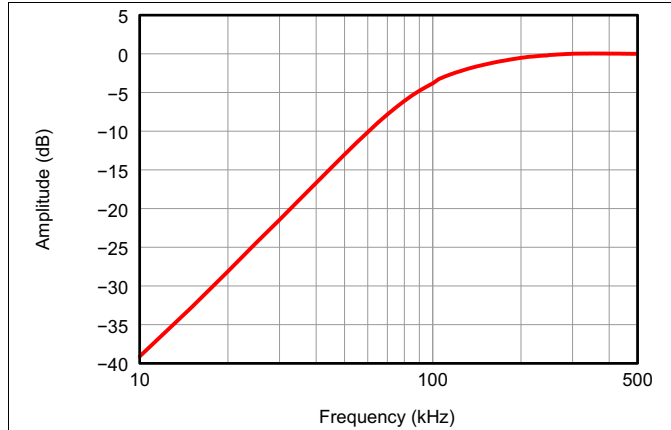

Figure 14. Full Channel HPF Response at Default Register Setting

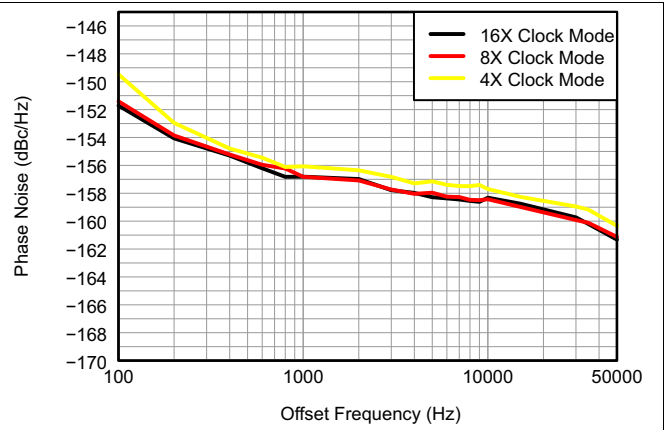

Figure 15. CW Phase Noise, F<sub>IN</sub> = 2 MHz

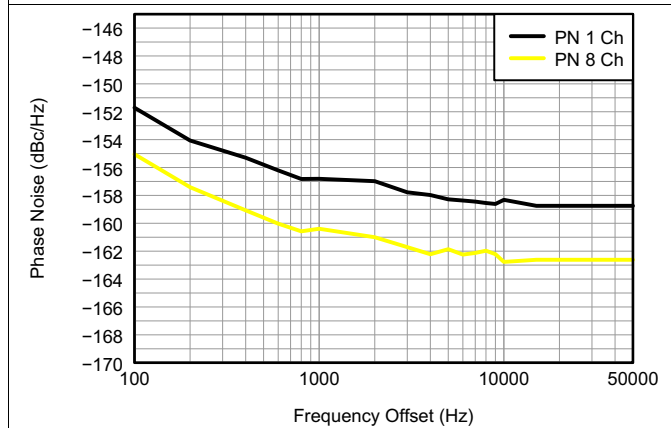

Figure 16. CW Phase Noise, F<sub>IN</sub> = 2 MHz, 1 Channel vs 8 Channel

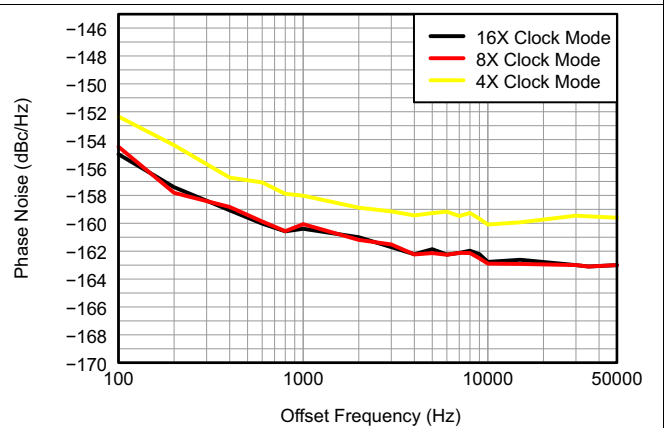

Figure 17. CW Phase Noise vs Clock Modes, F<sub>IN</sub> = 2 MHz

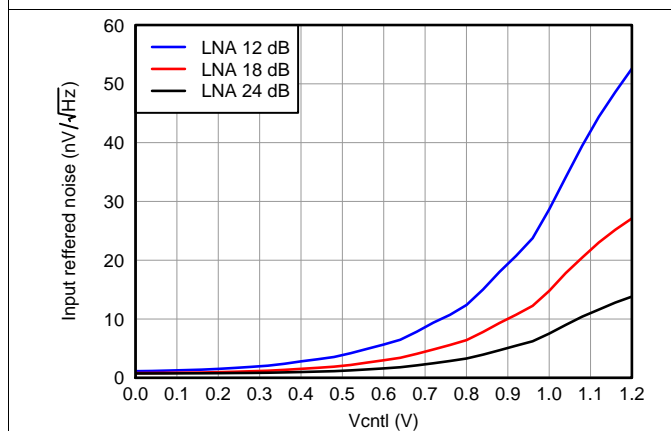

Figure 18. IRN, PGA = 24 dB and Low Noise Mode

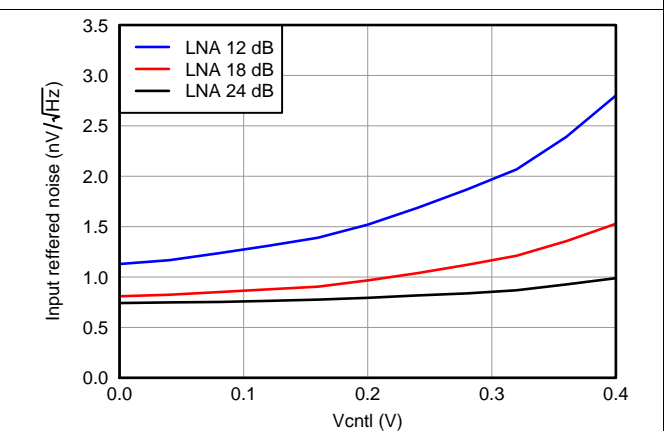

Figure 19. IRN, PGA = 24 dB and Low Noise Mode

**Typical Characteristics (continued)**

AVDD\_5 V = 5 V, AVDD = 3.3 V, AVDD\_ADC = 1.8 V, DVDD = 1.8 V, AC-coupled with 0.1- $\mu$ F capacitors at INP and 15-nF capacitors at INM, No active termination,  $V_{CNTL} = 0$  V,  $F_{IN} = 5$  MHz, LNA = 18 dB, PGA = 24 dB, 14 bit, sample rate = 65 MSPS, LPF filter = 15 MHz, low-noise mode, Single-ended  $V_{CNTL}$  mode,  $V_{CNTLM} = GND$ , ADC is configured in internal reference mode,  $V_{OUT} = -1$  dBFS, 500- $\Omega$  CW feedback resistor, CMOS 16x clock, digital demodulator is disabled, at ambient temperature  $T_A = 25^\circ\text{C}$ , unless otherwise noted.

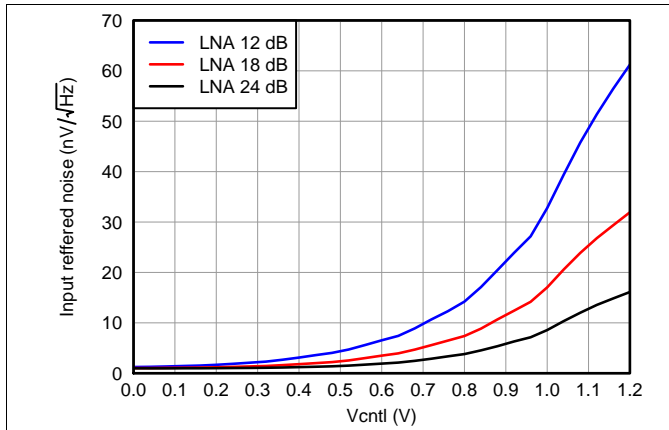

Figure 20. IRN, PGA = 24 dB and Medium-Power Mode

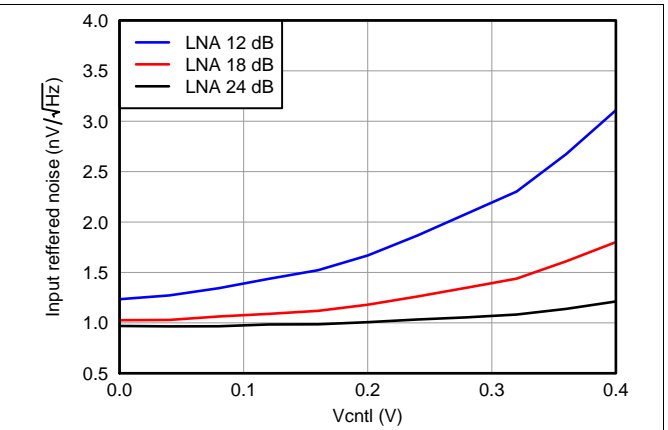

Figure 21. IRN, PGA = 24 dB and Medium-Power Mode

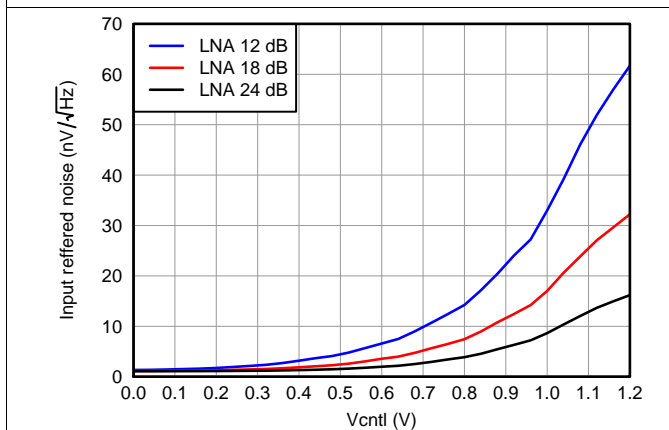

Figure 22. IRN, PGA = 24 dB and Low-Power Mode

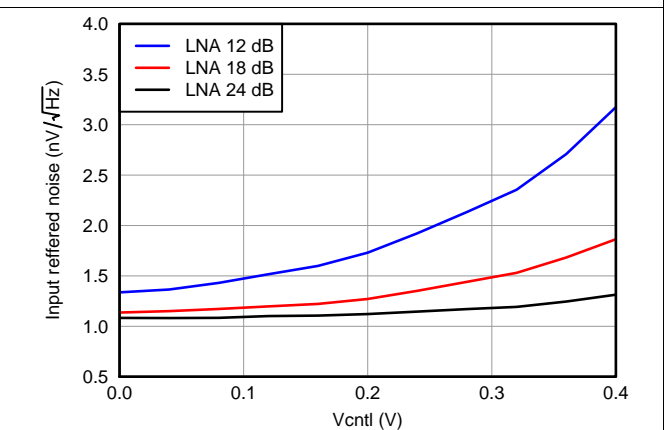

Figure 23. IRN, PGA = 24 dB and Low-Power Mode

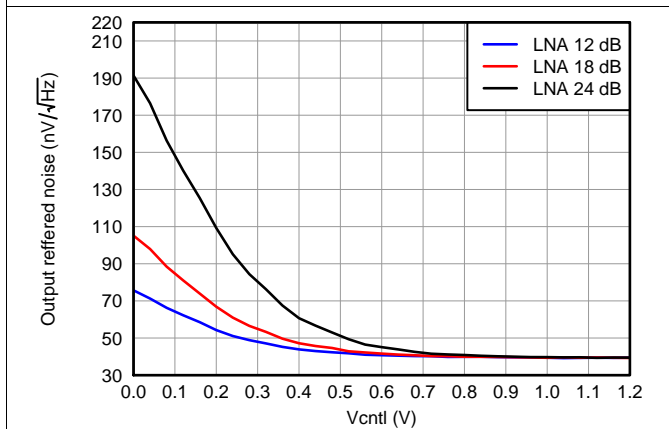

Figure 24. ORN, PGA = 24 dB and Low Noise Mode

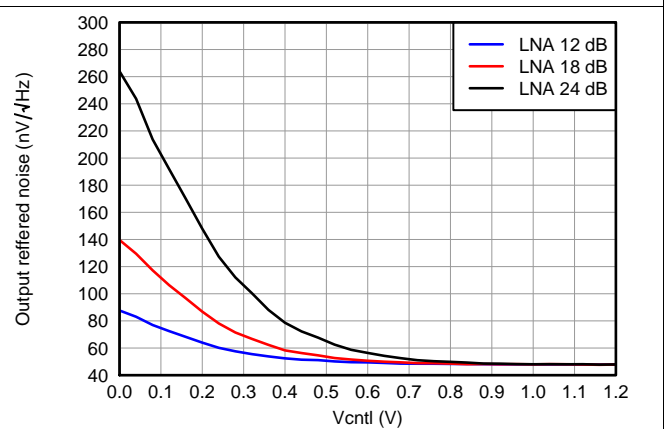

Figure 25. ORN, PGA = 24 dB and Medium-Power Mode

Typical Characteristics (continued)

AVDD\_5 V = 5 V, AVDD = 3.3 V, AVDD\_ADC = 1.8 V, DVDD = 1.8 V, AC-coupled with 0.1- $\mu$ F capacitors at INP and 15-nF capacitors at INM, No active termination,  $V_{CNTL} = 0$  V,  $F_{IN} = 5$  MHz, LNA = 18 dB, PGA = 24 dB, 14 bit, sample rate = 65 MSPS, LPF filter = 15 MHz, low-noise mode, Single-ended  $V_{CNTL}$  mode,  $V_{CNTLM} = GND$ , ADC is configured in internal reference mode,  $V_{OUT} = -1$  dBFS, 500- $\Omega$  CW feedback resistor, CMOS 16x clock, digital demodulator is disabled, at ambient temperature  $T_A = 25^\circ\text{C}$ , unless otherwise noted.

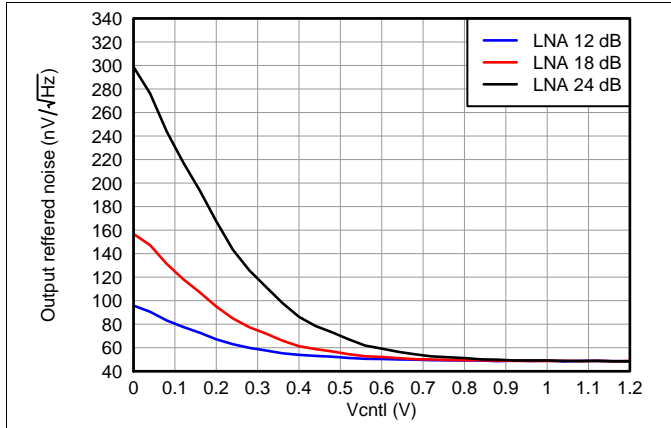

Figure 26. ORN, PGA = 24 dB and Low-Power Mode

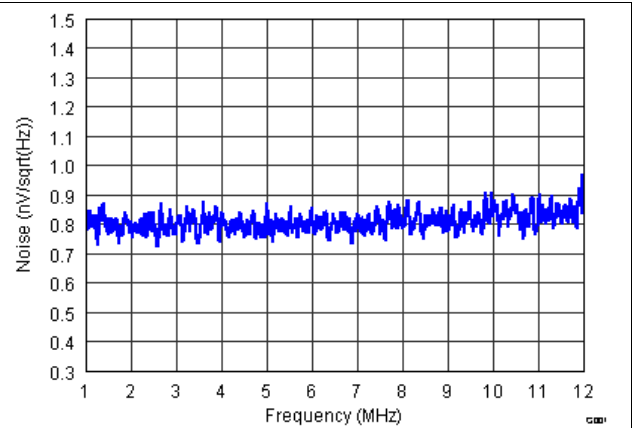

Figure 27. IRN, PGA = 24 dB and Low Noise Mode

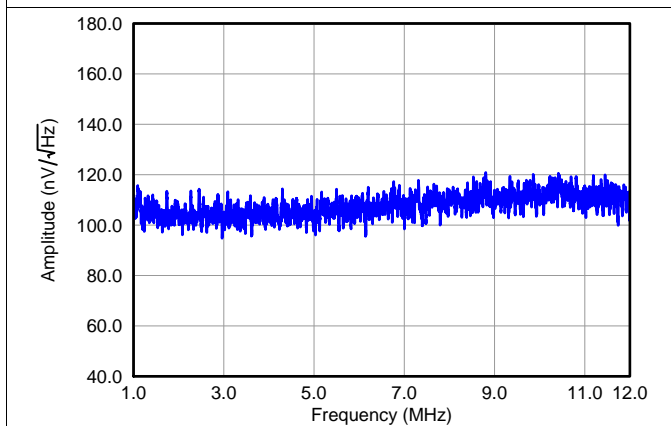

Figure 28. ORN, PGA = 24 dB and Low Noise Mode

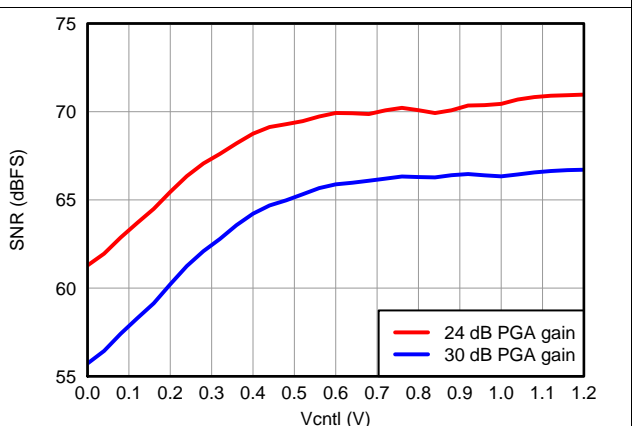

Figure 29. SNR, LNA = 18 dB and Low Noise Mode

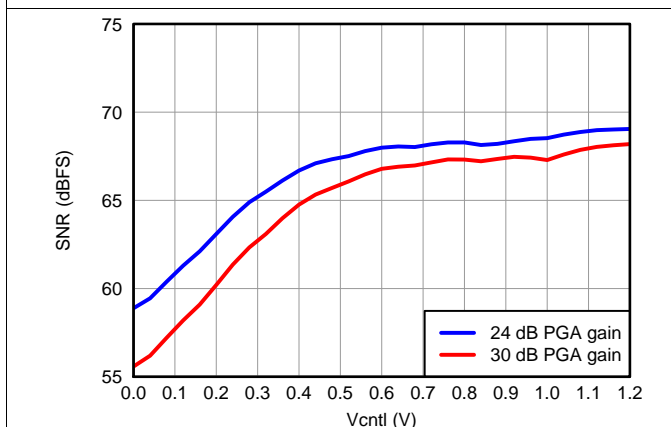

Figure 30. SNR, LNA = 18 dB and Low-Power Mode

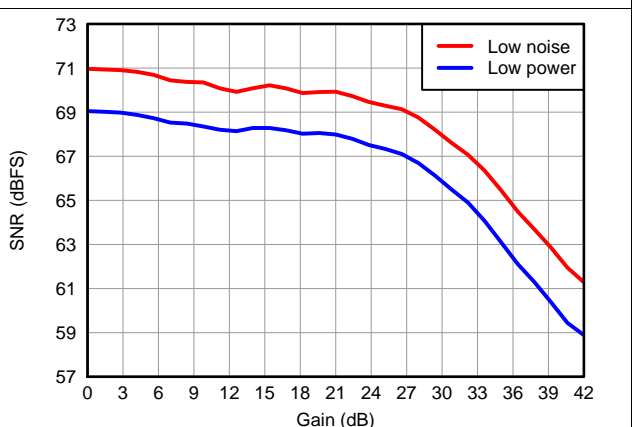

Figure 31. SNR vs Different Power Modes

Typical Characteristics (continued)

AVDD\_5 V = 5 V, AVDD = 3.3 V, AVDD\_ADC = 1.8 V, DVDD = 1.8 V, AC-coupled with 0.1- $\mu$ F capacitors at INP and 15-nF capacitors at INM, No active termination,  $V_{CNTL} = 0$  V,  $F_{IN} = 5$  MHz, LNA = 18 dB, PGA = 24 dB, 14 bit, sample rate = 65 MSPS, LPF filter = 15 MHz, low-noise mode, Single-ended  $V_{CNTLM} = GND$ , ADC is configured in internal reference mode,  $V_{OUT} = -1$  dBFS, 500- $\Omega$  CW feedback resistor, CMOS 16x clock, digital demodulator is disabled, at ambient temperature  $T_A = 25^\circ\text{C}$ , unless otherwise noted.

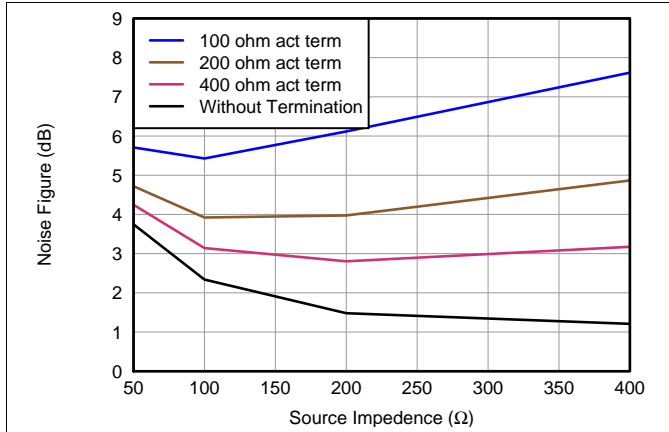

Figure 32. Noise Figure, LNA = 12 dB and Low Noise Mode

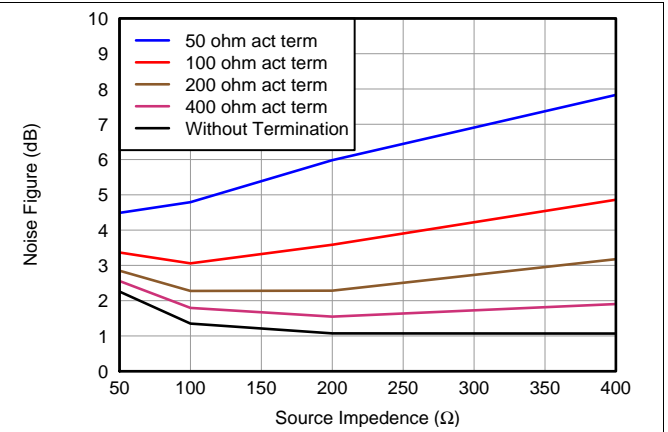

Figure 33. Noise Figure, LNA = 18 dB and Low Noise Mode

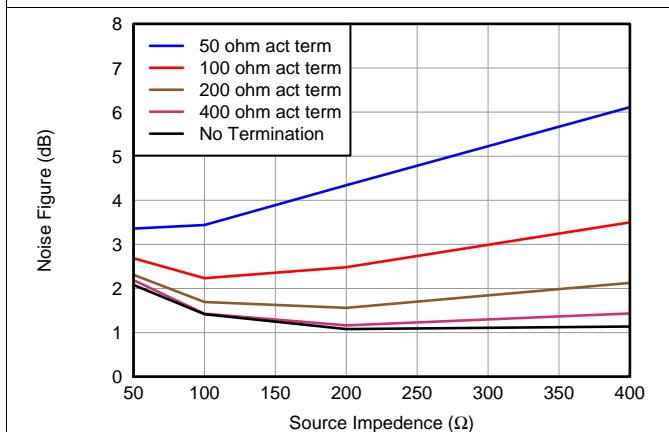

Figure 34. Noise Figure, LNA = 24 dB and Low Noise Mode

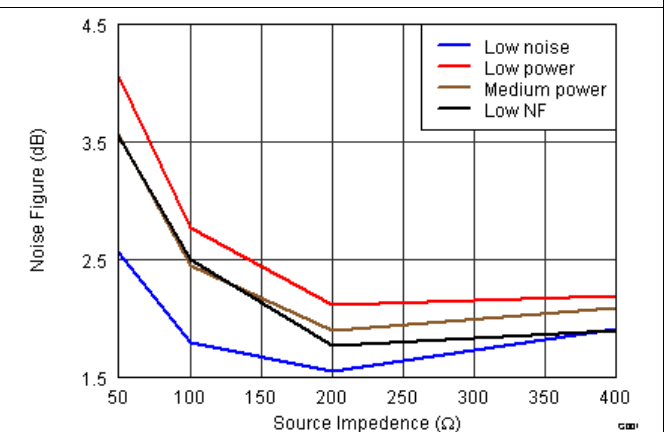

Figure 35. Noise Figure vs Power Modes With 400- $\Omega$  Termination

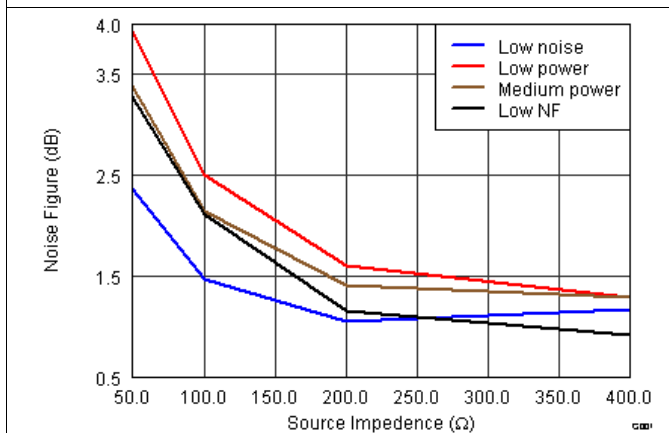

Figure 36. Noise Figure vs Power Modes Without Termination

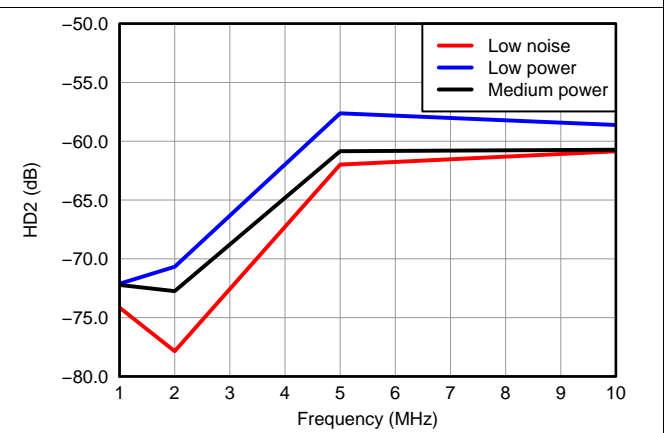

Figure 37. HD2 vs Frequency,  $V_{IN} = 500$  mVpp and  $V_{OUT} = -1$  dBFS

Typical Characteristics (continued)

AVDD\_5 V = 5 V, AVDD = 3.3 V, AVDD\_ADC = 1.8 V, DVDD = 1.8 V, AC-coupled with 0.1- $\mu$ F capacitors at INP and 15-nF capacitors at INM, No active termination,  $V_{CNTL} = 0$  V,  $F_{IN} = 5$  MHz, LNA = 18 dB, PGA = 24 dB, 14 bit, sample rate = 65 MSPS, LPF filter = 15 MHz, low-noise mode, Single-ended  $V_{CNTL}$  mode,  $V_{CNTLM} = GND$ , ADC is configured in internal reference mode,  $V_{OUT} = -1$  dBFS, 500- $\Omega$  CW feedback resistor, CMOS 16x clock, digital demodulator is disabled, at ambient temperature  $T_A = 25^\circ\text{C}$ , unless otherwise noted.

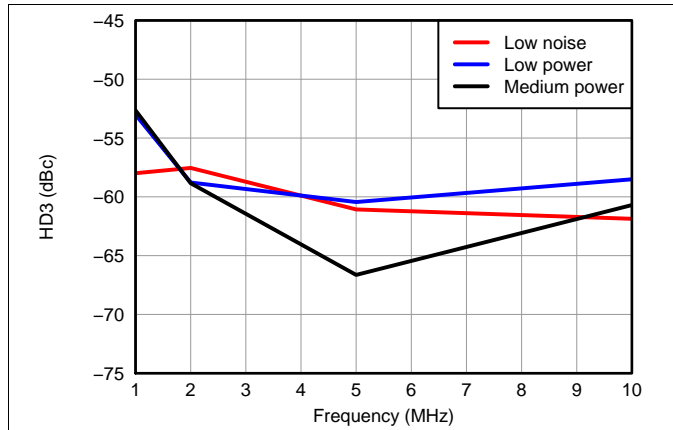

Figure 38. HD3 vs Frequency,  $V_{IN} = 500$  mVpp and  $V_{OUT} = -1$  dBFS

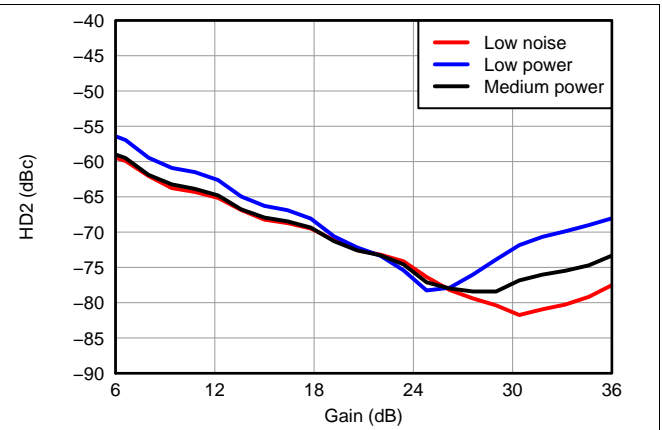

Figure 39. HD2 vs Gain, LNA = 12 dB and PGA = 24 dB and  $V_{OUT} = -1$  dBFS

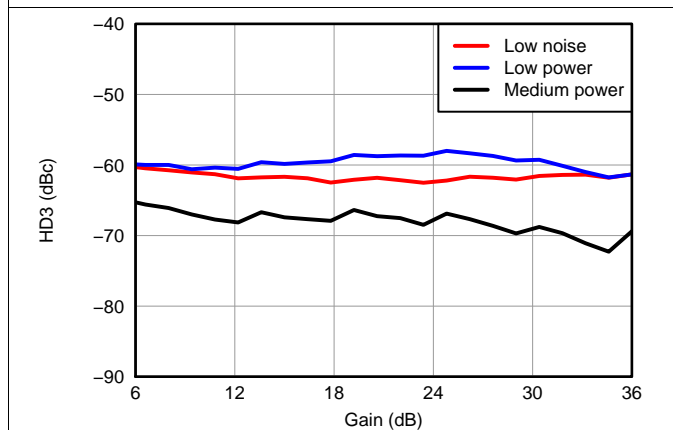

Figure 40. HD3 vs Gain, LNA = 12 dB and PGA = 24 dB and  $V_{OUT} = -1$  dBFS

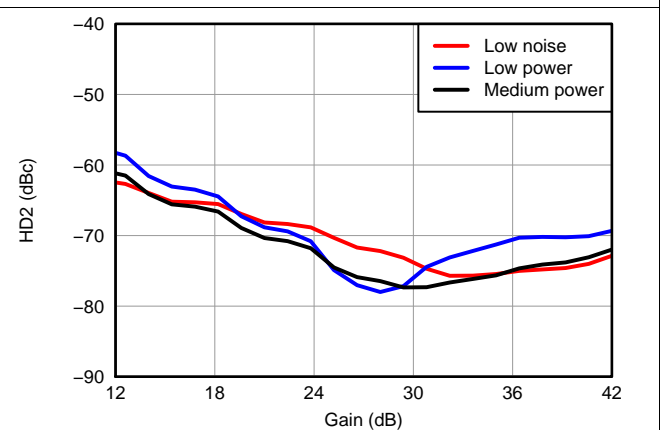

Figure 41. HD2 vs Gain, LNA = 18 dB and PGA = 24 dB and  $V_{OUT} = -1$  dBFS

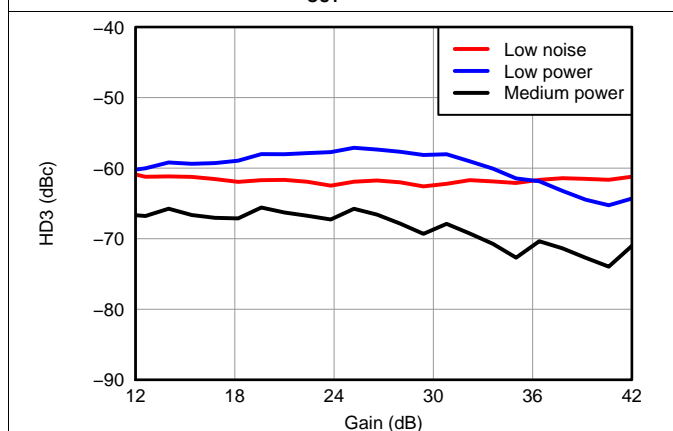

Figure 42. HD3 vs Gain, LNA = 18 dB and PGA = 24 dB and  $V_{OUT} = -1$  dBFS

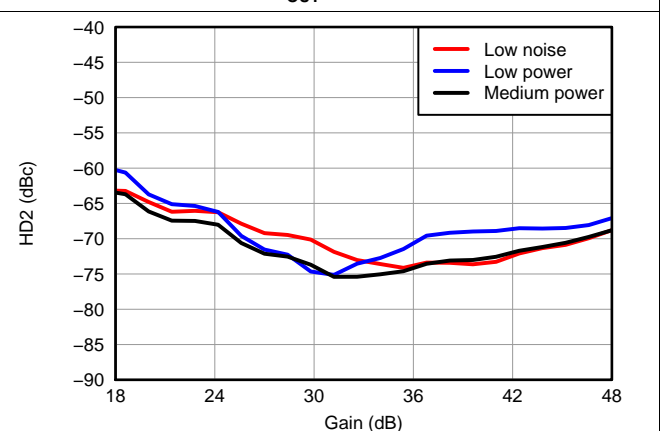

Figure 43. HD2 vs Gain, LNA = 24 dB and PGA = 24 dB and  $V_{OUT} = -1$  dBFS

Typical Characteristics (continued)

AVDD\_5 V = 5 V, AVDD = 3.3 V, AVDD\_ADC = 1.8 V, DVDD = 1.8 V, AC-coupled with 0.1- $\mu$ F capacitors at INP and 15-nF capacitors at INM, No active termination,  $V_{CNTL} = 0$  V,  $F_{IN} = 5$  MHz, LNA = 18 dB, PGA = 24 dB, 14 bit, sample rate = 65 MSPS, LPF filter = 15 MHz, low-noise mode, Single-ended  $V_{CNTL}$  mode,  $V_{CNTLM} = GND$ , ADC is configured in internal reference mode,  $V_{OUT} = -1$  dBFS, 500- $\Omega$  CW feedback resistor, CMOS 16x clock, digital demodulator is disabled, at ambient temperature  $T_A = 25^\circ\text{C}$ , unless otherwise noted.

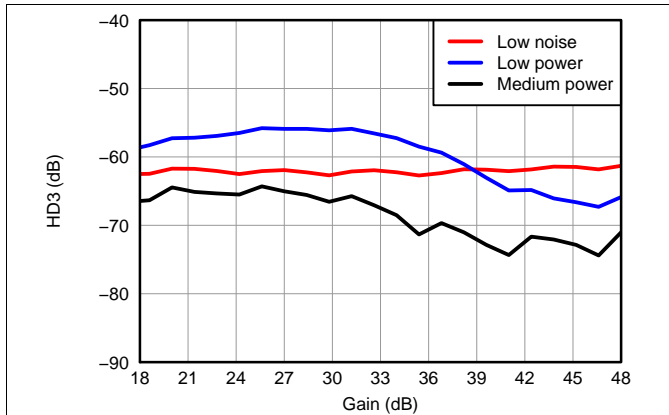

Figure 44. HD3 vs Gain, LNA = 24 dB and PGA = 24 dB and  $V_{OUT} = -1$  dBFS

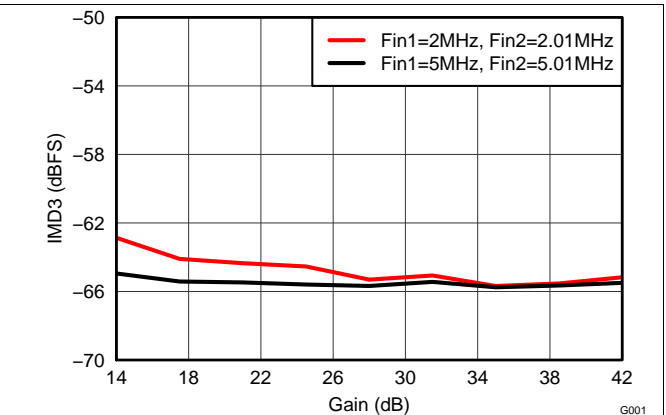

Figure 45. IMD3,  $F_{out1} = -7$  dBFS and  $F_{out2} = -21$  dBFS

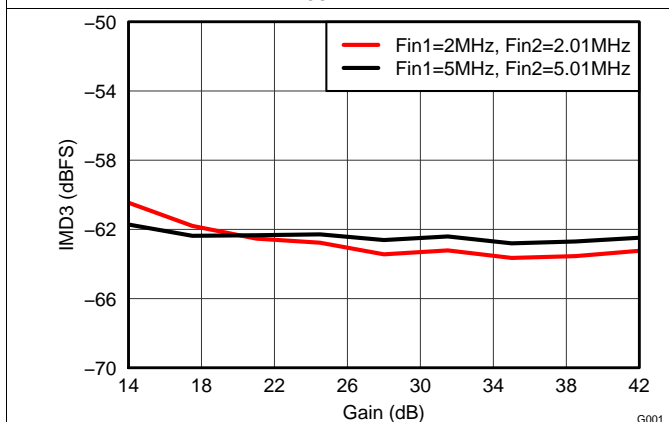

Figure 46. IMD3,  $F_{out1} = -7$  dBFS and  $F_{out2} = -7$  dBFS

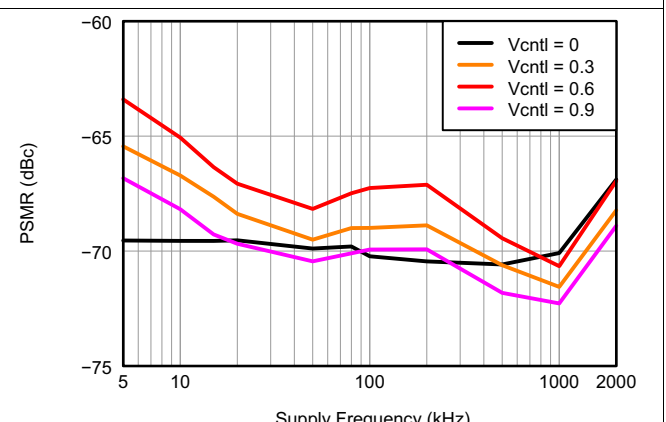

Figure 47. AVDD Power Supply Modulation Ratio, 100 mVpp Supply Noise With Different Frequencies

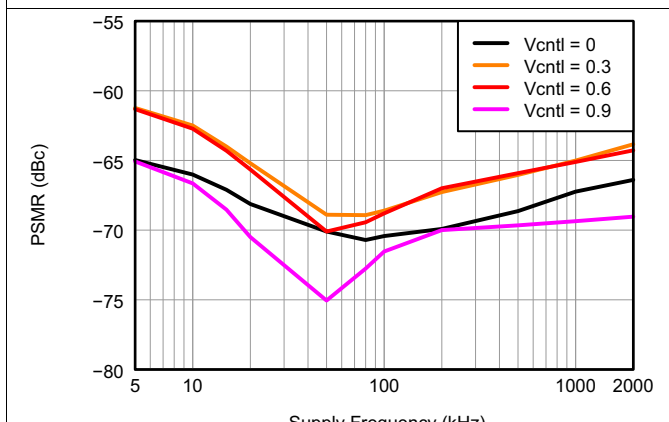

Figure 48. AVDD\_5V Power Supply Modulation Ratio, 100 mVpp Supply Noise With Different Frequencies

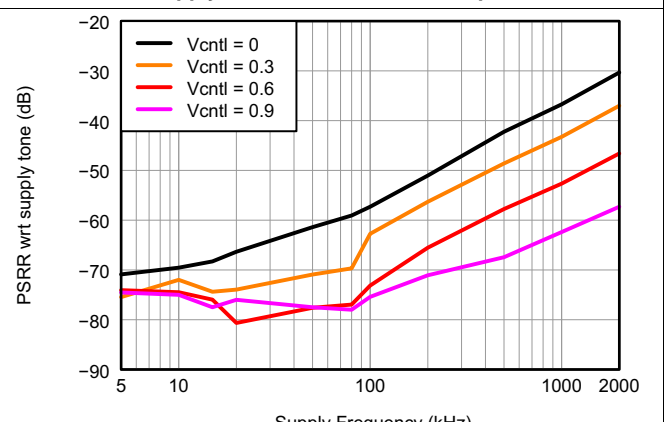
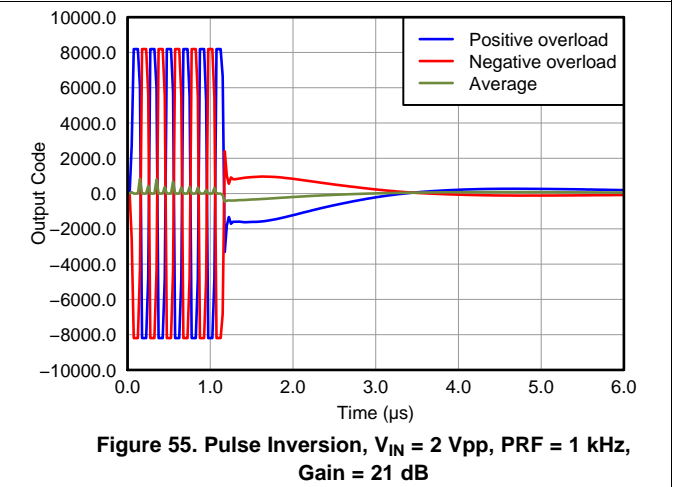
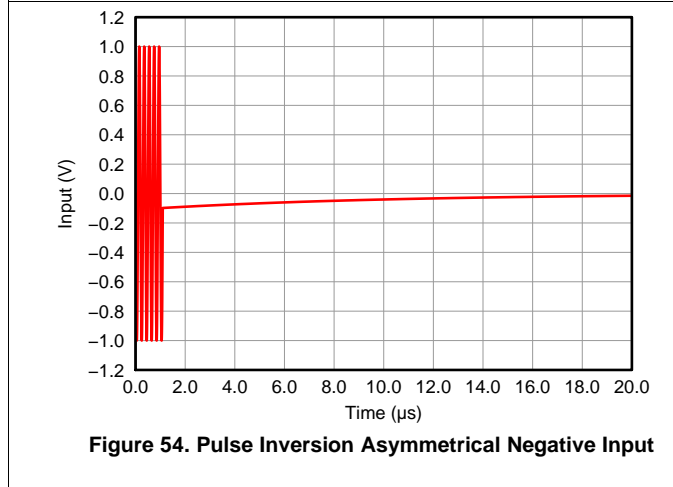
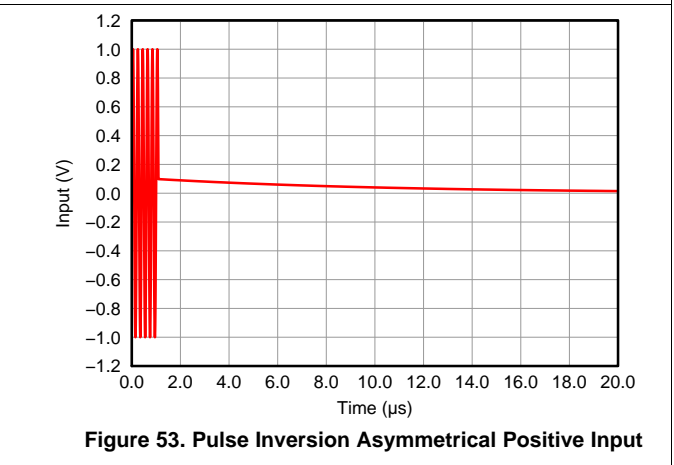
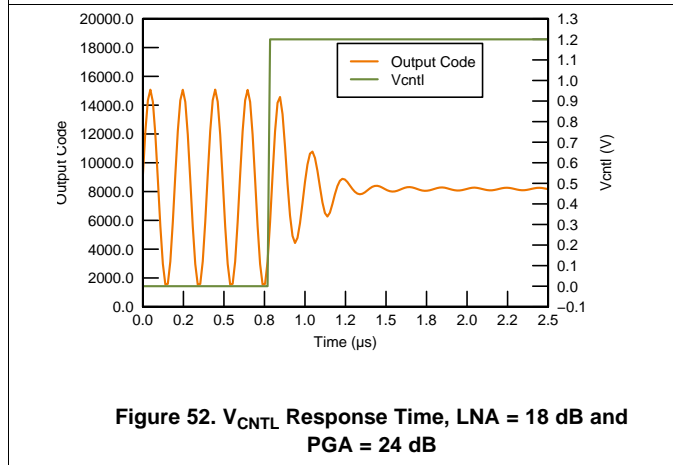
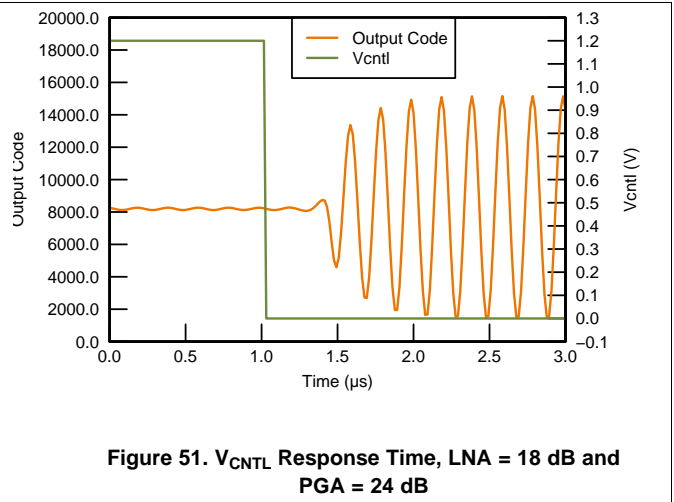
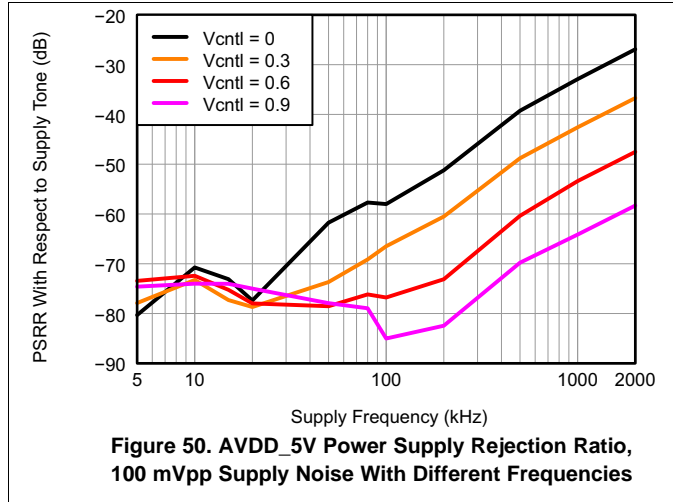

Figure 49. AVDD Power Supply Rejection Ratio, 100 mVpp Supply Noise With Different Frequencies

Typical Characteristics (continued)

AVDD\_5 V = 5 V, AVDD = 3.3 V, AVDD\_ADC = 1.8 V, DVDD = 1.8 V, AC-coupled with 0.1- $\mu$ F capacitors at INP and 15-nF capacitors at INM, No active termination, V<sub>CNTL</sub> = 0 V, F<sub>IN</sub> = 5 MHz, LNA = 18 dB, PGA = 24 dB, 14 bit, sample rate = 65 MSPS, LPF filter = 15 MHz, low-noise mode, Single-ended V<sub>CNTL</sub> mode, V<sub>CNTLM</sub> = GND, ADC is configured in internal reference mode, V<sub>OUT</sub> = -1 dBFS, 500- $\Omega$  CW feedback resistor, CMOS 16 $\times$  clock, digital demodulator is disabled, at ambient temperature T<sub>A</sub> = 25°C, unless otherwise noted.



Typical Characteristics (continued)

AVDD\_5 V = 5 V, AVDD = 3.3 V, AVDD\_ADC = 1.8 V, DVDD = 1.8 V, AC-coupled with 0.1- $\mu$ F capacitors at INP and 15-nF capacitors at INM, No active termination, V<sub>CNTL</sub> = 0 V, F<sub>IN</sub> = 5 MHz, LNA = 18 dB, PGA = 24 dB, 14 bit, sample rate = 65 MSPS, LPF filter = 15 MHz, low-noise mode, Single-ended V<sub>CNTL</sub> mode, V<sub>CNTLM</sub> = GND, ADC is configured in internal reference mode, V<sub>OUT</sub> = -1 dBFS, 500- $\Omega$  CW feedback resistor, CMOS 16 $\times$  clock, digital demodulator is disabled, at ambient temperature T<sub>A</sub> = 25°C, unless otherwise noted.

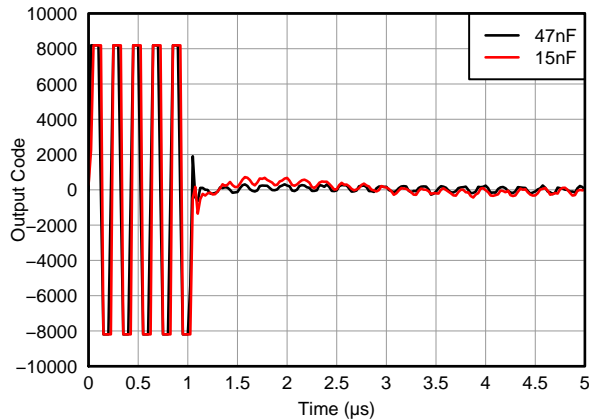

Figure 56. Overload Recovery Response vs INM Capacitor, V<sub>IN</sub> = 50 mVpp/100  $\mu$ Vpp, Max Gain

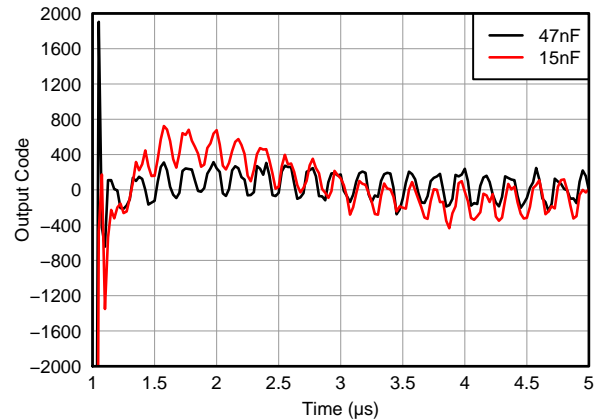

Figure 57. Overload Recovery Response vs INM Capacitor (Zoomed), V<sub>IN</sub> = 50 mVpp/100  $\mu$ Vpp, Max Gain

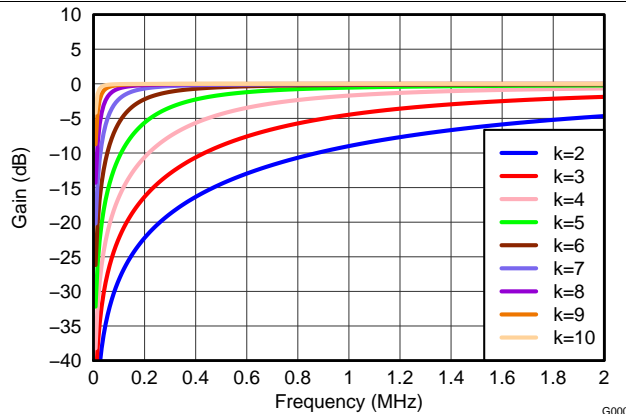

Figure 58. Digital HPF Response

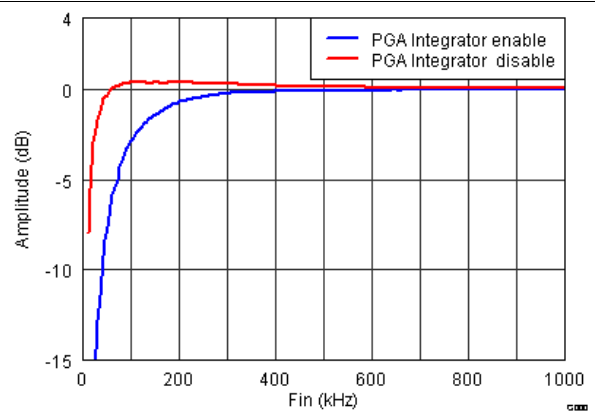

Figure 59. Signal Chain Low Frequency Response With INM Capacitor = 1  $\mu$ F

## 8 Detailed Description

### 8.1 Overview

The AFE5809 device is a highly-integrated AFE solution specifically designed for ultrasound systems in which high performance and small size are required. The AFE5809 device integrates a complete TGC imaging path and a CWD path. It also enables users to select one of various power/noise combinations to optimize system performance. The AFE5809 device contains eight channels; each channel includes a LNA, VCAT, PGA, LPF, 14-bit ADC, digital I/Q demodulator, and CW mixer.

Multiple features in the AFE5809 device are suitable for ultrasound applications, such as active termination, individual channel control, fast power-up and power-down response, programmable clamp voltage control, and fast and consistent overload recovery. Therefore, the AFE5809 device brings premium image quality to ultraportable, handheld systems all the way up to high-end ultrasound systems.

In addition, the signal chain of the AFE5809 device can handle signal frequency as low as 50 kHz and as high as 30 MHz. This enables the AFE5809 device to be used in both sonar and medical applications.

Figure 60 shows a simplified functional block diagram.

### 8.2 Functional Block Diagram

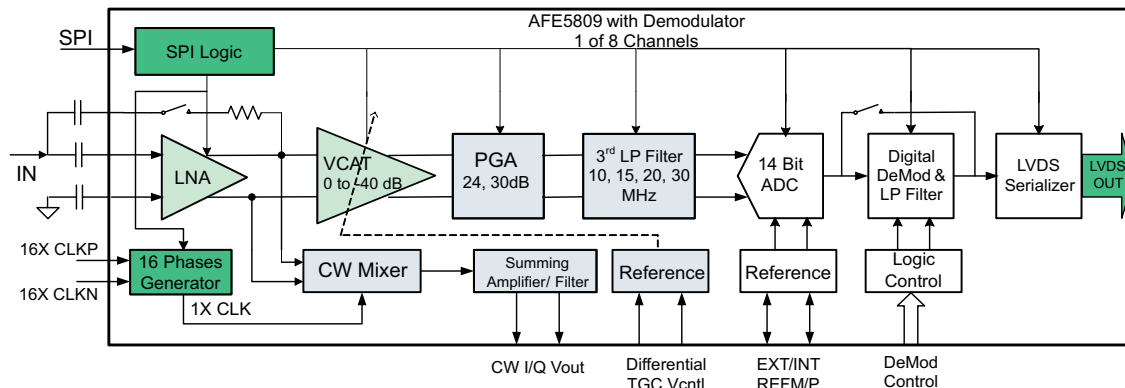

Figure 60. Simplified Functional Block Diagram

Functional Block Diagram (continued)

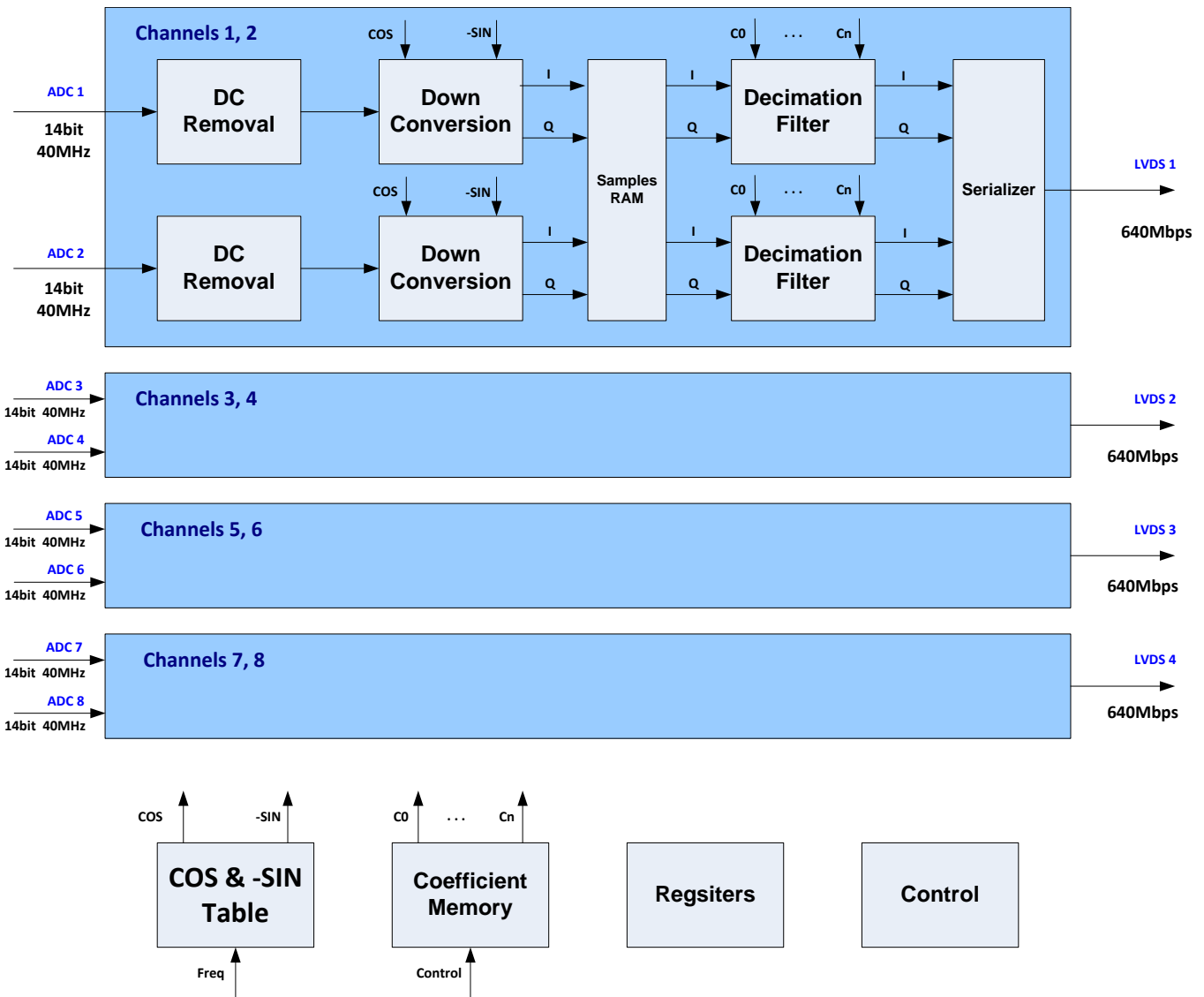

Figure 61. Digital Demodulator Block Diagram

8.3 Feature Description

8.3.1 LNA

In many high-gain systems, a LNA is critical to achieve overall performance. Using a new proprietary architecture, the LNA in the AFE5809 device delivers exceptional low-noise performance, while operating on a low-quiescent current compared to CMOS-based architectures with similar noise performance. The LNA performs single-ended input to differential output voltage conversion. It is configurable for a programmable gain of 24, 18, or 12 dB and its input-referred noise is only 0.63, 0.7, or 0.9 nV/√Hz, respectively. Programmable gain settings result in a flexible linear input range up to 1 Vpp, realizing high-signal handling capability demanded by new transducer technologies. A larger input signal can be accepted by the LNA; however, the signal can be distorted because it exceeds the LNA's linear operation region. Combining the low noise and high-input range, the device consequently achieves a wide-input dynamic range for supporting the high demands from various ultrasound imaging modes.

## Feature Description (continued)

The LNA input is internally biased at approximately 2.4 V; the signal source should be AC-coupled to the LNA input by an adequately-sized capacitor, for example  $\geq 0.1 \mu\text{F}$ . To achieve low DC offset drift, the AFE5809 device incorporates a DC offset correction circuit for each amplifier stage. To improve the overload recovery, an integrator circuit is used to extract the DC component of the LNA output and then fed back to the LNA's complementary input for DC offset correction. This DC offset correction circuit has a high-pass response and can be treated as a HPF. The effective corner frequency is determined by the capacitor  $C_{\text{BYPASS}}$  connected at INM. With larger capacitors, the corner frequency is lower. For stable operation at the highest HP filter cut-off frequency, a  $\geq 15\text{-nF}$  capacitor can be selected. This corner frequency scales almost linearly with the value of the  $C_{\text{BYPASS}}$ . For example, 15 nF gives a corner frequency of approximately 100 kHz, while 47 nF can give an effective corner frequency of 33 kHz. The DC offset correction circuit can also be disabled or enabled through register 52[12]. A large capacitor like 1  $\mu\text{F}$  can be used for setting low corner frequency ( $< 2 \text{ kHz}$ ) of the LNA DC offset correction circuit. Figure 59 shows the frequency responses for low-frequency applications.

The AFE5809 device can be terminated passively or actively. Active termination is preferred in ultrasound applications for reducing reflection from mismatches and achieving better axial resolution without degrading noise figure too much. Active termination values can be preset to 50, 100, 200, and 400  $\Omega$ ; other values also can be programmed by users through register 52[4:0]. A feedback capacitor is required between ACTx and the signal source as Figure 62 shows. On the active termination path, a clamping circuit is also used to create a low-impedance path when overload signal is seen by the AFE5809 device. The clamp circuit limits large input signals at the LNA inputs and improves the overload recovery performance of the AFE5809 device. The clamp level can be set to 350 mVpp, 600 mVpp, or 1.15 Vpp automatically depending on the LNA gain settings when register 52[10:9] = 0. Other clamp voltages, such as 1.15 Vpp, 0.6 Vpp, and 1.5 Vpp, are also achievable by setting register 52[10:9]. This clamping circuit is also designed to obtain good pulse inversion performance and reduce the impact from asymmetric inputs.

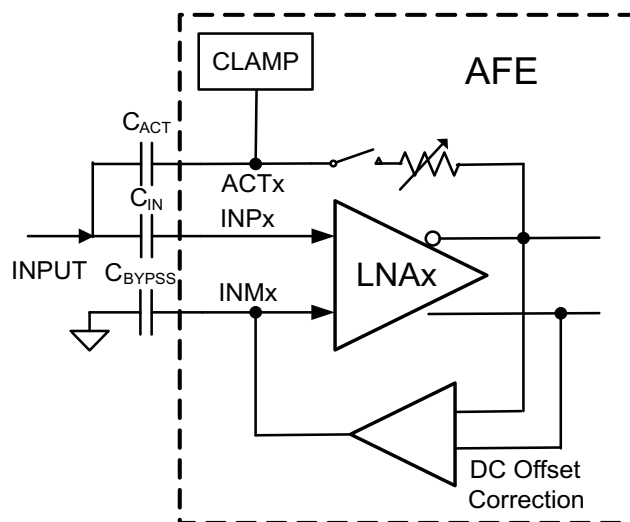

Figure 62. AFE5809 LNA With DC Offset Correction Circuit

### 8.3.2 Voltage-Controlled Attenuator

The voltage-controlled attenuator is designed to have a linear-in-dB attenuation characteristic; that is, the average gain loss in dB (refer to Figure 2) is constant for each equal increment of the control voltage (VCNTL) as shown in Figure 63. A differential control structure is used to reduce common mode noise. Figure 63 and Figure 64 show a simplified attenuator structure.

The attenuator is essentially a variable voltage divider that consists of the series input resistor ( $R_S$ ) and seven shunt FETs placed in parallel and controlled by sequentially activated clipping amplifiers (A1 through A7). VCNTL is the effective difference between VCNTLP and VCNTLM. Each clipping amplifier can be understood as a specialized voltage comparator with a soft transfer characteristic and well-controlled output limit voltage. Reference voltages V1 through V7 are equally spaced over the 0- to 1.5-V control voltage range. As the control voltage increases through the input range of each clipping amplifier, the amplifier output rises from a voltage where the FET is nearly OFF to VHIGH where the FET is completely ON. As each FET approaches its ON state

## Feature Description (continued)

and the control voltage continues to rise, the next clipping amplifier/FET combination takes over for the next portion of the piecewise-linear attenuation characteristic. Thus, low control voltages have most of the FETs turned OFF, producing minimum signal attenuation. Similarly, high control voltages turn the FETs ON, leading to maximum signal attenuation. Therefore, each FET acts to decrease the shunt resistance of the voltage divider formed by  $R_S$  and the parallel FET network.

Additionally, a digitally-controlled TGC mode is implemented to achieve better phase-noise performance in the AFE5809 device. The attenuator can be controlled digitally instead of the analog control voltage,  $V_{CNTL}$ . This mode can be set by the register bit 59[7]. The variable voltage divider is implemented as a fixed series resistance and FET as the shunt resistance. Each FET can be turned on by connecting the switches SW1 through SW7. Turning on each of the switches can give approximately 6 dB of attenuation. This can be controlled by the register bits 59[6:4]. This digital control feature can eliminate the noise from the  $V_{CNTL}$  circuit and ensure better SNR and phase noise for the TGC path.

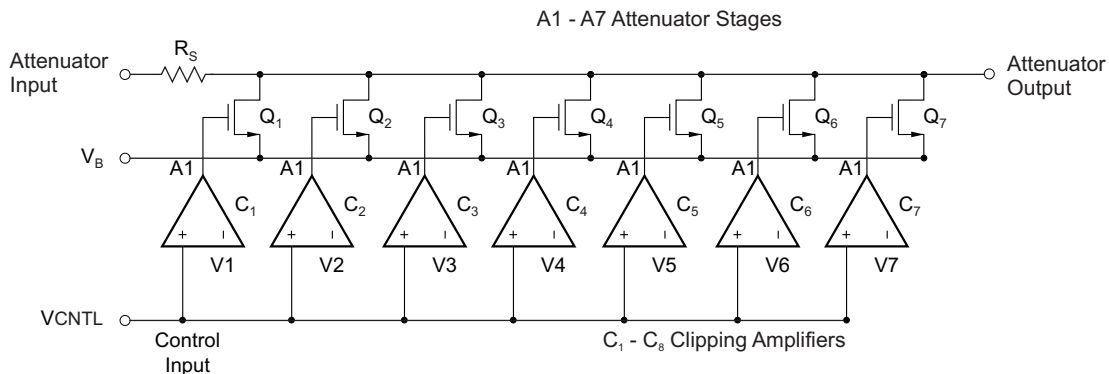

Figure 63. Simplified Voltage-Controlled Attenuator (Analog Structure)

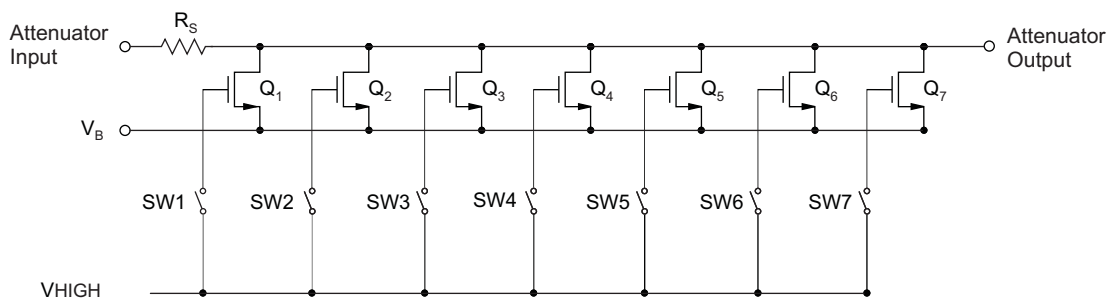

Figure 64. Simplified Voltage-Controlled Attenuator (Digital Structure)

The voltage-controlled attenuator's noise follows a monotonic relationship to the attenuation coefficient. At higher attenuation, the input-referred noise is higher and vice-versa. The attenuator's noise is then amplified by the PGA and becomes the noise floor at ADC input. In the attenuator's high-attenuation operating range, that is  $V_{CNTL}$  is high, the attenuator's input noise may exceed the LNA output noise; the attenuator then becomes the dominant noise source for the following PGA stage and ADC. Therefore, the attenuator noise should be minimized compared to the LNA output noise. The AFE5809 attenuator is designed for achieving very-low noise even at high attenuation (low channel gain) and realizing better SNR in near field. Table 1 lists the input referred noise for different attenuations.

**Table 1. Voltage-Controlled-Attenuator Noise versus Attenuation**

ATTENUATION (dB)	ATTENUATOR INPUT REFERRED NOISE (nV/rtHz)
-40	10.5
-36	10
-30	9
-24	8.5
-18	6
-12	4
-6	3
0	2

### 8.3.3 PGA

After the voltage-controlled attenuator, a PGA can be configured as 24 or 30 dB with a constant-input referred noise of 1.75 nV/rtHz. The PGA structure consists of a differential voltage-to-current converter with programmable gain, clamping circuits, a transimpedance amplifier with a programmable LPF, and a DC offset correction circuit. Figure 65 shows its simplified block diagram.

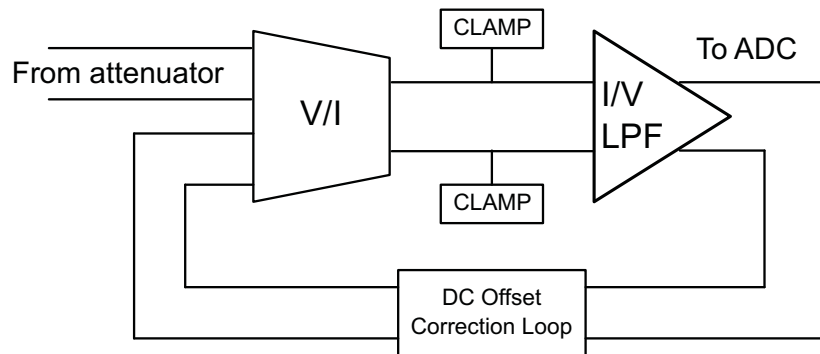

**Figure 65. Simplified Block Diagram of PGA**

Low input noise is always preferred in a PGA, and its noise contribution should not degrade the ADC SNR too much after the attenuator. At the minimum attenuation (used for small input signals), the LNA noise dominates; at the maximum attenuation (large input signals), the PGA and ADC noise dominates. Thus, 24-dB gain of PGA achieves better SNR as long as the amplified signals can exceed the noise floor of the ADC.

The PGA clamping circuit can be enabled (register 51) to improve the overload recovery performance of the AFE. If the user measures the standard deviation of the output just after overload, for  $0.5 V_{CNTL}$ , it is about 3.2 LSBs in normal case, that is, the output is stable in about 1 clock cycle after overload. With the clamp disabled, the value approaches 4 LSBs meaning a longer time duration before the output stabilizes; however, with the clamp enabled, there will be degradation in HD3 for PGA output levels  $>-2$  dBFS. For example, for a  $-2$ -dBFS output level, the HD3 degrades by approximately 3 dB. To maximize the output dynamic range, the maximum PGA output level can be above  $2 V_{pp}$  even with the clamp circuit enabled; the ADC in the AFE5809 device has excellent overload recovery performance to detect small signals right after the overload.

#### NOTE

In the low-power and medium-power modes, PGA\_CLAMP is disabled for saving power if 51[7] = 0.

The AFE5809 device integrates an anti-aliasing filter in the form of a programmable LPF in the transimpedance amplifier. The LPF is designed as a differential, active, third-order filter with Butterworth characteristics and a typical 18 dB per octave roll-off. Programmable through the serial interface, the  $-1$ -dB frequency corner can be set to one of 10, 15, 20, and 30 MHz. The filter bandwidth is set for all channels simultaneously.

A selectable DC offset correction circuit is implemented in the PGA as well. This correction circuit is similar to the one used in the LNA. It extracts the DC component of the PGA outputs and feeds back to the PGA complementary inputs for DC offset correction. This DC offset correction circuit also has a high-pass response with a cut-off frequency of 80 kHz.

### 8.3.4 ADC

The ADC of the AFE5809 device employs a pipelined converter architecture that consists of a combination of multi-bit and single-bit internal stages. Each stage feeds its data into the digital error correction logic, ensuring excellent differential linearity and no missing codes at the 14-bit level. The 14 bits given out by each channel are serialized and sent out on a single pair of pins in LVDS format. All eight channels of the AFE5809 device operate from a common input clock (CLKP/M). The sampling clocks for each of the eight channels are generated from the input clock using a carefully matched clock buffer tree. The 14x clock required for the serializer is generated internally from the CLKP/M pins. A 7x and 1x clock are also given out in LVDS format, along with the data, to enable easy data capture. The AFE5809 device operates from internally-generated reference voltages that are trimmed to improve the gain matching across devices. The nominal values of REFP and REFM are 1.5 and 0.5 V, respectively. Alternatively, the device also supports an external reference mode that can be enabled using the serial interface.

Using serialized LVDS transmission has multiple advantages, such as a reduced number of output pins (saving routing space on the board), reduced power consumption, and reduced effects of digital-noise coupling to the analog circuit inside the AFE5809 device.

### 8.3.5 Continuous-Wave (CW) Beamformer

CWD is a key function in mid-end to high-end ultrasound systems. Compared to the TGC mode, the CW path needs to handle high dynamic range along with strict phase-noise performance. CW beamforming is often implemented in analog domain due to the strict requirements. Multiple beamforming methods are implemented in ultrasound systems, including passive delay line, active mixer, and passive mixer. Among all of them, the passive mixer approach achieves optimized power and noise. It satisfies the CW processing requirements, such as wide dynamic range, low phase noise, accurate gain and phase matching.

[Figure 66](#) and [Figure 67](#) show a simplified CW path block diagram and an in-phase or quadrature (I/Q) channel block diagram, respectively. Each CW channel includes a LNA, a voltage-to-current converter, a switch-based mixer, a shared summing amplifier with a LPF, and clocking circuits.

---

#### NOTE

The local oscillator inputs of the passive mixer are  $\cos(\omega t)$  for I-CH and  $\sin(\omega t)$  for Q-CH respectively. Depending on the users' CW Doppler complex FFT processing, swapping I/Q channels in FPGA or DSP may be needed to get correct blood flow directions.

---

All blocks include well-matched in-phase and quadrature channels to achieve good image frequency rejection as well as beamforming accuracy. As a result, the image rejection ratio from an I/Q channel is better than  $-46$  dBc, which is desired in ultrasound systems.

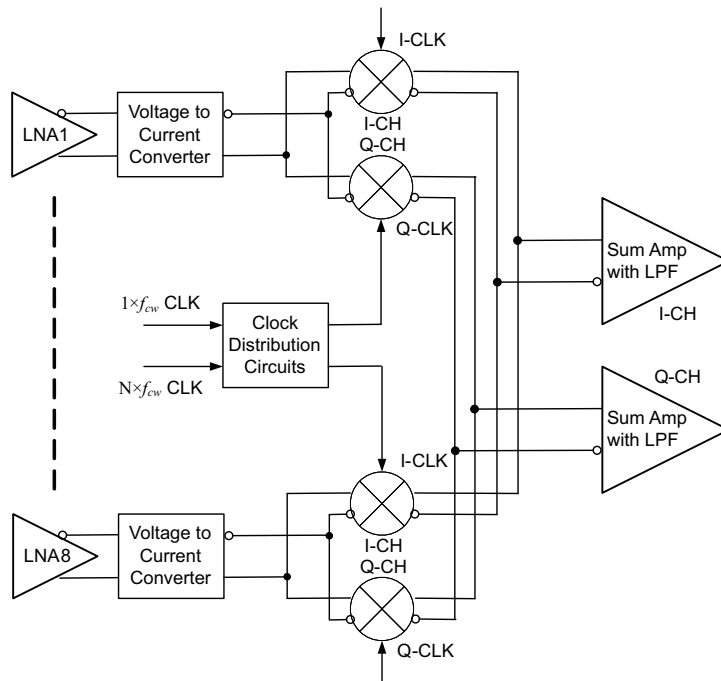
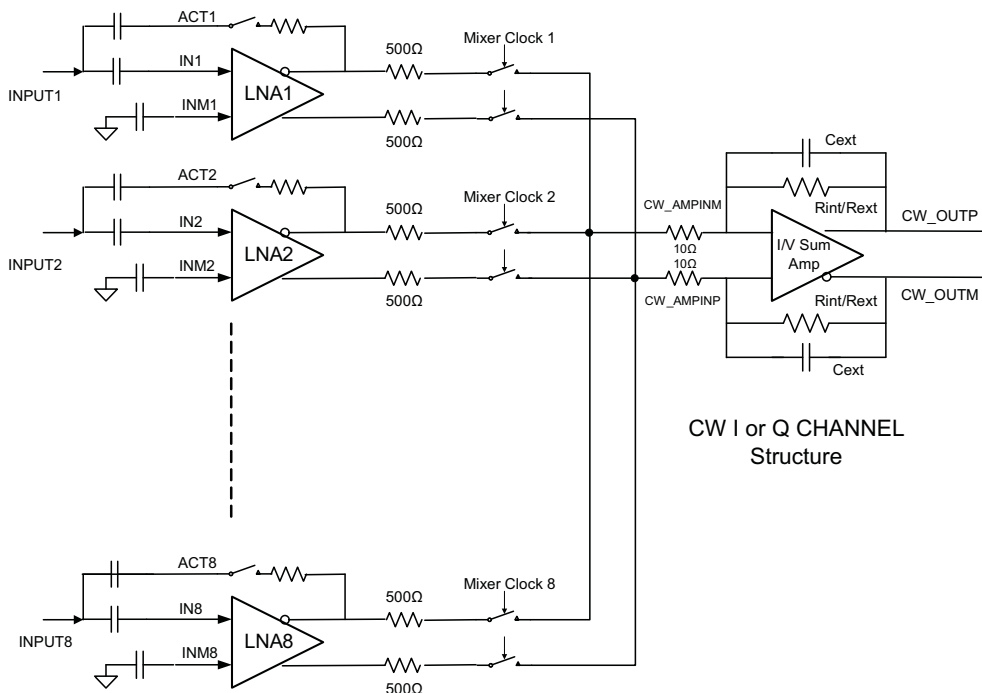

Figure 66. Simplified Block Diagram of CW Path



Note: The approximately 10- to 15-Ω resistors at CW\_AMPINM/P are due to internal IC routing and can create slight attenuation.

Figure 67. Complete In-Phase or Quadrature-Phase Channel

The CW mixer in the AFE5809 device is passive and switch based; a passive mixer adds less noise than an active mixer. It achieves good performance at low power. Figure 68 and the equations describe the principles of mixer operation, where  $V_i(t)$ ,  $V_o(t)$ , and  $LO(t)$  are input, output, and local oscillator (LO) signals for a mixer respectively. The  $LO(t)$  is square-wave based and includes odd harmonic components, as shown in Equation 1.

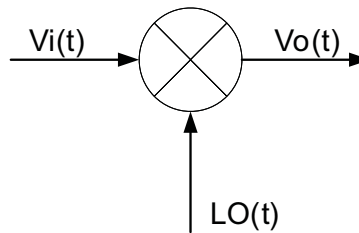
**Figure 68. Block Diagram of Mixer Operation**

$$\begin{aligned}
 V_i(t) &= \sin(\omega_0 t + \omega_d t + \phi) + f(\omega_0 t) \\
 LO(t) &= \frac{4}{\pi} \left[ \sin(\omega_0 t) + \frac{1}{3} \sin(3\omega_0 t) + \frac{1}{5} \sin(5\omega_0 t) \dots \right] \\
 V_o(t) &= \frac{2}{\pi} \left[ \cos(\omega_d t + \phi) - \cos(2\omega_0 t - \omega_d t + \phi) \dots \right]
 \end{aligned} \tag{1}$$

From [Equation 1](#), the third-order and fifth-order harmonics from the LO can interface with the third-order and fifth-order harmonic signals in the  $V_i(t)$ , or the noise around the third-order and fifth-order harmonics in the  $V_i(t)$ . Therefore, the mixer's performance is degraded. To eliminate this side effect due to the square-wave demodulation, a proprietary harmonic-suppression circuit is implemented in the AFE5809 device. The third- and fifth-harmonic components from the LO can be suppressed by over 12 dB. Thus, the LNA output noise around the third-order and fifth-order harmonic bands is not down-converted to base band. Hence, the device achieves better noise figure. The conversion loss of the mixer is about  $-4$  dB, which is derived from  $20 \log_{10} \frac{2}{\pi}$ .

The mixed current outputs of the eight channels are summed together internally. An internal low-noise operational amplifier is used to convert the summed current to a voltage output. The internal summing amplifier is designed to accomplish low-power consumption, low noise, and ease of use. CW outputs from multiple AFE5809 devices can be further combined on system board to implement a CW beamformer with more than eight channels. See [Typical Application](#) for more detailed information.

Multiple clock options are supported in the AFE5809 CW path. Two CW clock inputs are required:  $N \times f_{CW}$  clock and  $1 \times f_{CW}$  clock, where  $f_{CW}$  is the CW transmitting frequency and  $N$  could be 16, 8, 4, or 1. Users have the flexibility to select the most convenient system clock solution for the AFE5809 device. In the  $16 \times f_{CW}$  and  $8 \times f_{CW}$  modes, the third- and fifth-harmonic suppression feature can be supported. Thus, the  $16 \times f_{CW}$  and  $8 \times f_{CW}$  modes achieve better performance than the  $4 \times f_{CW}$  and  $1 \times f_{CW}$  modes.

### 8.3.5.1 $16 \times f_{CW}$ Mode

The  $16 \times f_{CW}$  mode achieves the best phase accuracy compared to other modes. It is the default mode for CW operation. In this mode,  $16 \times f_{CW}$  and  $1 \times f_{CW}$  clocks are required.  $16 \times f_{CW}$  generates LO signals with 16 accurate phases. Multiple AFE5809 devices can be synchronized by the  $1 \times f_{CW}$ , that is LO signals in multiple AFEs can have the same starting phase. The phase noise specification is critical only for  $16 \times$  clock. The  $1 \times$  clock is for synchronization only and does not require low phase noise. See the phase noise requirement in [Typical Application](#).

[Figure 69](#) shows the top-level clock distribution diagram. Each mixer's clock is distributed through a  $16 \times 8$  cross-point switch. The inputs of the cross-point switch are 16 different phases of the  $1 \times f_{CW}$ . TI recommends aligning the rising edges of the  $1 \times f_{CW}$  and  $16 \times f_{CW}$  clocks.

The cross-point switch distributes the clocks with appropriate phase delay to each mixer. For example,  $V_i(t)$  is a received signal with a delay of  $\frac{1}{16} T$ , a delayed  $LO(t)$  should be applied to the mixer to compensate for the  $\frac{1}{16} T$  delay. Thus a  $22.5^\circ$  delayed clock, that is  $\frac{2\pi}{16}$ , is selected for this channel. The mathematic calculation is expressed in the following equations:

$$V_i(t) = \sin \left[ \omega_0 \left( t + \frac{1}{16f_0} \right) + \omega_d t \right] = \sin [\omega_0 t + 22.5^\circ + \omega_d t]$$

$$LO(t) = \frac{4}{\pi} \sin \left[ \omega_0 \left( t + \frac{1}{16f_0} \right) \right] = \frac{4}{\pi} \sin [\omega_0 t + 22.5^\circ]$$

$$V_o(t) = \frac{2}{\pi} \cos(\omega_d t) + f(\omega_n t) \tag{2}$$

$V_o(t)$  represents the demodulated Doppler signal of each channel. When the Doppler signals from N channels are summed, the signal-to-noise ratio improves.

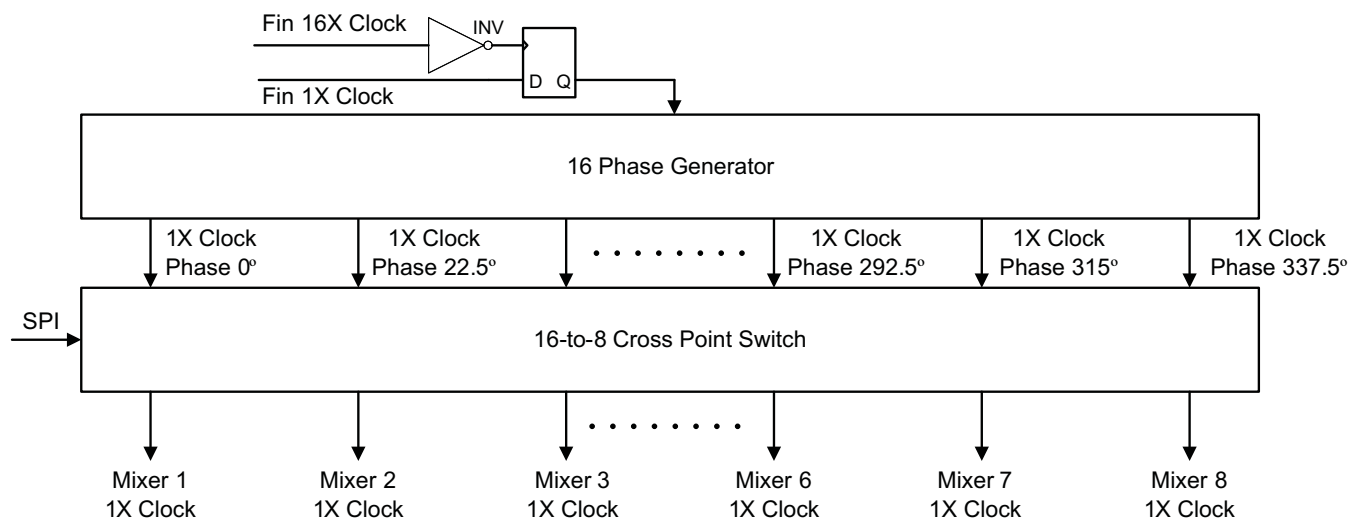
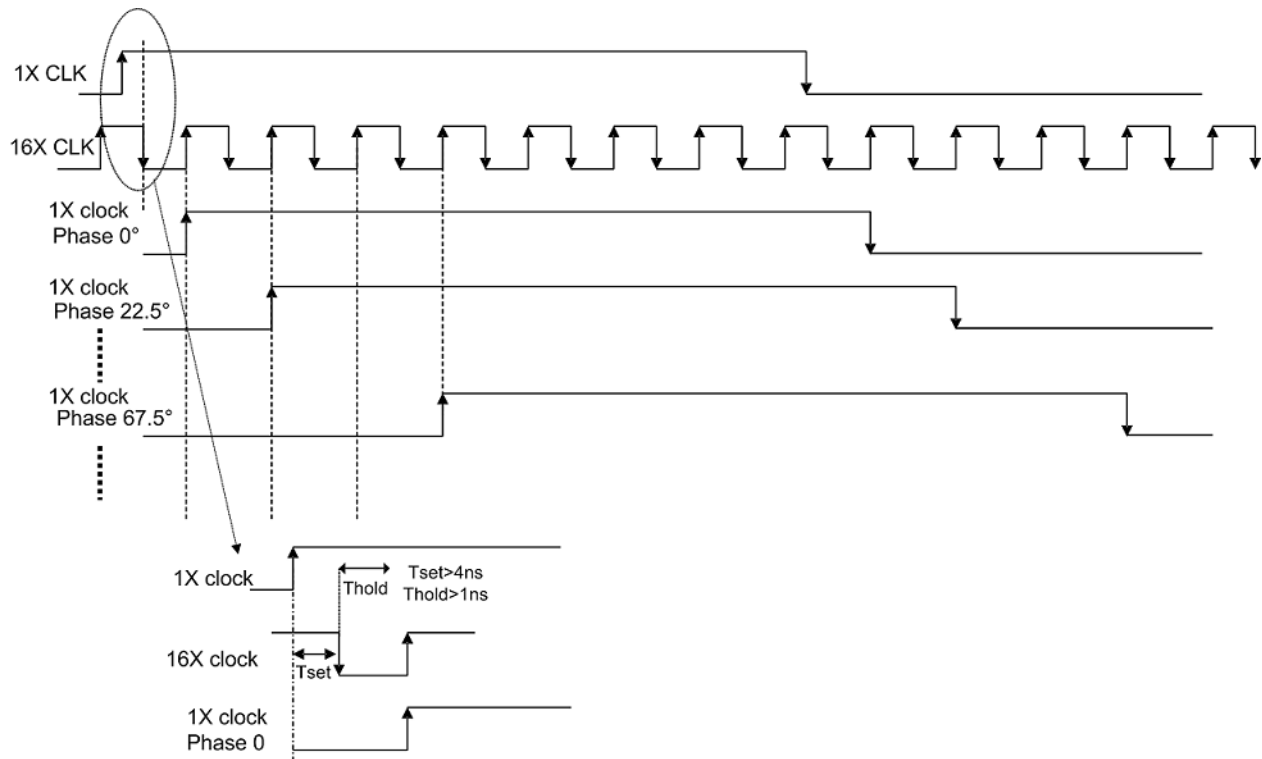

Figure 69.

**Figure 70. 1x and 16x CW Clock Timing**

### 8.3.5.2 $8 \times f_{CW}$ and $4 \times f_{CW}$ Modes

$8 \times f_{CW}$  and  $4 \times f_{CW}$  modes are alternative modes when a higher frequency clock solution (that is  $16 \times f_{CW}$  clock) is not available in system. Figure 71 shows a block diagram of these two modes.

Good phase accuracy and matching are also maintained. Quadrature clock generator is used to create in-phase and quadrature clocks with exactly  $90^\circ$  phase difference. The only difference between  $8 \times f_{CW}$  and  $4 \times f_{CW}$  modes is the accessibility of the third- and fifth-harmonic suppression filter. In the  $8 \times f_{CW}$  mode, the suppression filter can be supported. In both modes,  $\frac{1}{16}T$  phase delay resolution is achieved by weighting the in-phase and quadrature paths correspondingly. For example, if a delay of  $\frac{1}{16}T$  or  $22.5^\circ$  is targeted, the weighting coefficients should follow Equation 3, assuming  $I_{in}$  and  $Q_{in}$  are  $\sin(\omega_0 t)$  and  $\cos(\omega_0 t)$  respectively.

$$I_{\text{delayed}}(t) = I_{in} \cos\left(\frac{2\pi}{16}\right) + Q_{in} \sin\left(\frac{2\pi}{16}\right) = I_{in} \left( t + \frac{1}{16f_0} \right)$$

$$Q_{\text{delayed}}(t) = Q_{in} \cos\left(\frac{2\pi}{16}\right) - I_{in} \sin\left(\frac{2\pi}{16}\right) = Q_{in} \left( t + \frac{1}{16f_0} \right) \quad (3)$$

Therefore, after I/Q mixers, phase delay in the received signals is compensated. The mixers' outputs from all channels are aligned and added linearly to improve the signal-to-noise ratio. It is preferred to have the  $4 \times f_{CW}$  or  $8 \times f_{CW}$  and  $1 \times f_{CW}$  clocks both aligned at the rising edge.

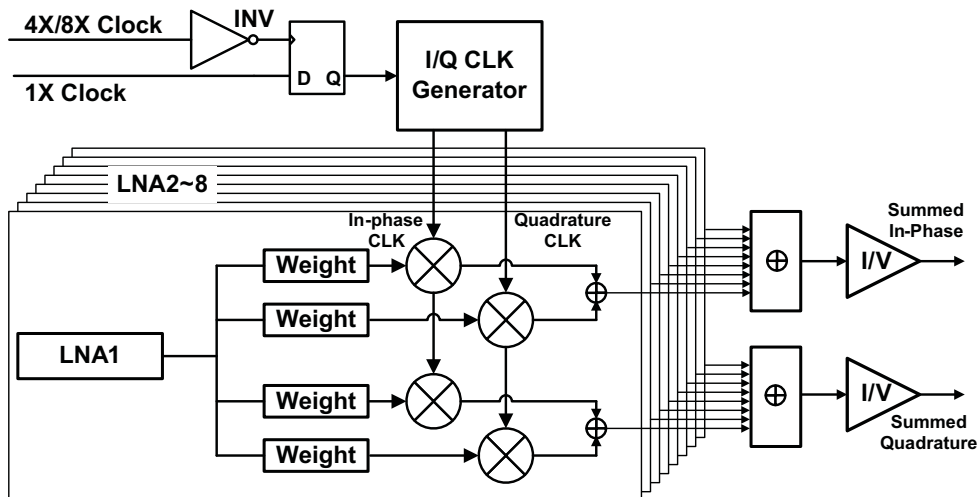

Figure 71.  $8 \times f_{cw}$  and  $4 \times f_{cw}$  Block Diagram

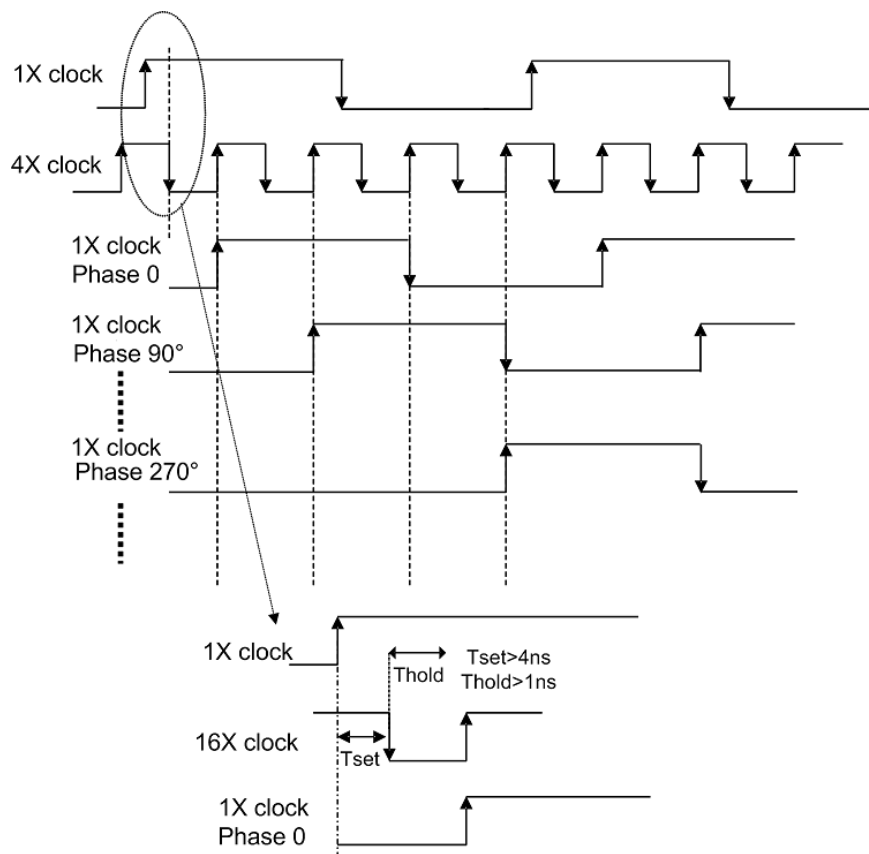
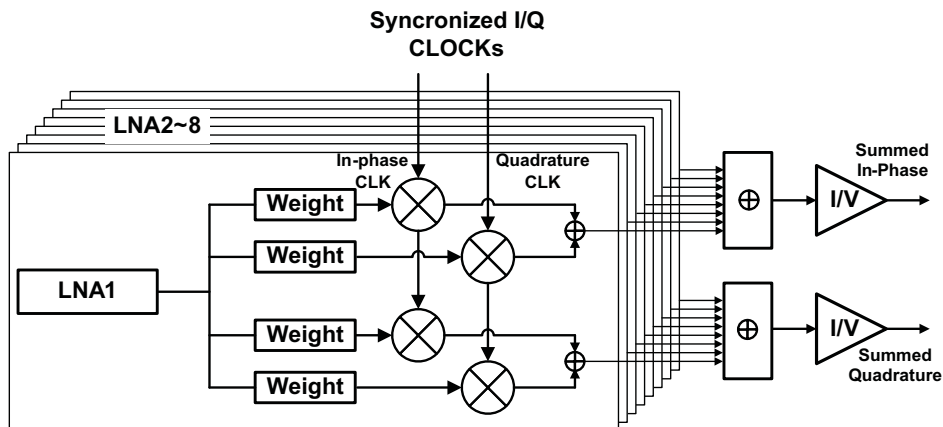

Figure 72.  $8 \times f_{cw}$  and  $4 \times f_{cw}$  Timing Diagram

### 8.3.5.3 $1 \times f_{cw}$ Mode

The  $1 \times f_{cw}$  mode requires in-phase and quadrature clocks with low phase noise specifications. The  $\frac{1}{16}T$  phase delay resolution is also achieved by weighting the in-phase and quadrature signals as described in the  $8 \times f_{cw}$  and  $4 \times f_{cw}$  modes.

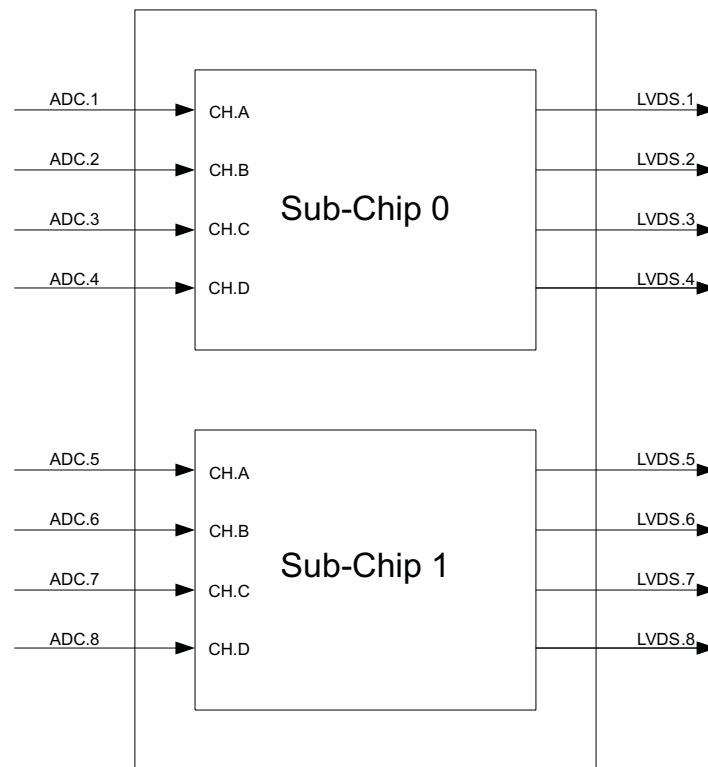

**Figure 73. Block Diagram of  $1 \times f_{cw}$  mode**

### 8.3.6 Digital I/Q Demodulator

The AFE5809 device also includes a digital in-phase and quadrature (I/Q) demodulator and a low-pass decimation filter. The main purpose of the demodulation block is to reduce the LVDS data rate and improve overall system power efficiency. The I/Q demodulator accepts ADC output with up to 65-MSPS sampling rate and 14-bit resolution. For example, after digital demodulation and  $4\times$  decimation filtering, the data rate for either in-phase or quadrature output is reduced to 16.25 MSPS, and the data resolution is improved to 16 bits consequently. Hence, the overall LVDS trace reduction can be a factor of 2. This demodulator can be bypassed and powered down completely if it is not needed.

The digital demodulator block given in the AFE5809 device is designed to do down-conversion followed by decimation. The top-level block is divided into two exactly similar blocks: (1) subchip0 and (2) subchip1. Both subchips share four channels each, that is, subchip0 (ADC.1, ADC.2, ADC.3, and ADC.4) and subchip1 (ADC.5, ADC.6, ADC.7, and ADC.8).



**Figure 74. Subchip**

The following four functioning blocks are given in each demodulator. Every block can be bypassed.

- DC removal block
- Down conversion
- Decimator
- Channel multiplexing

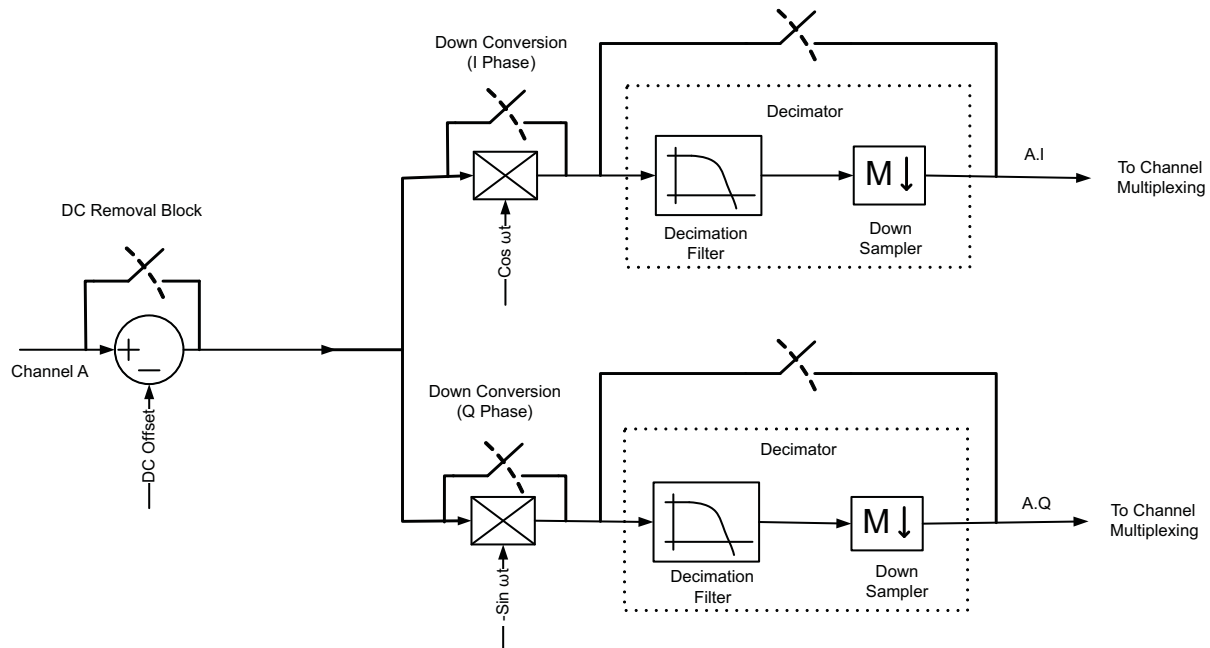

**Figure 75. Digital Demodulator Block**

1. DC removal block is used to remove DC offset. An offset value can be given to a specific register.
2. Down conversion or demodulation of signal is done by multiplying signal by  $\cos(\omega_0 t)$  and by  $-\sin(\omega_0 t)$  to give out I phase and Q phase, respectively.  $\cos(\omega t)$  and  $-\sin(\omega t)$  are 14-bit wide plus a sign bit.  $\omega = 2\pi f$ ,  $f$  can be set with resolution  $F_s / 2^{16}$ , where  $F_s$  is the ADC sampling frequency.

**NOTE**

The digital demodulator is based on a conventional down converter, that is,  $-\sin(\omega_0 t)$  is used for Q phase.

3. The decimator block has two functions: decimation filter and down sampler. Decimation filter is a variable coefficient symmetric FIR filter and its coefficients can be given using coefficient RAM. Number of taps of FIR filter is  $16 \times$  decimation factor ( $M$ ). For decimation factor of  $M$ ,  $8M$  coefficients must be stored in the coefficient bank. Each coefficient is 14-bit wide. Down-sampler gives out 1 sample followed by  $M - 1$  samples zeros.
4. In [Figure 76](#), channel multiplexing is implemented for flexible data routing:

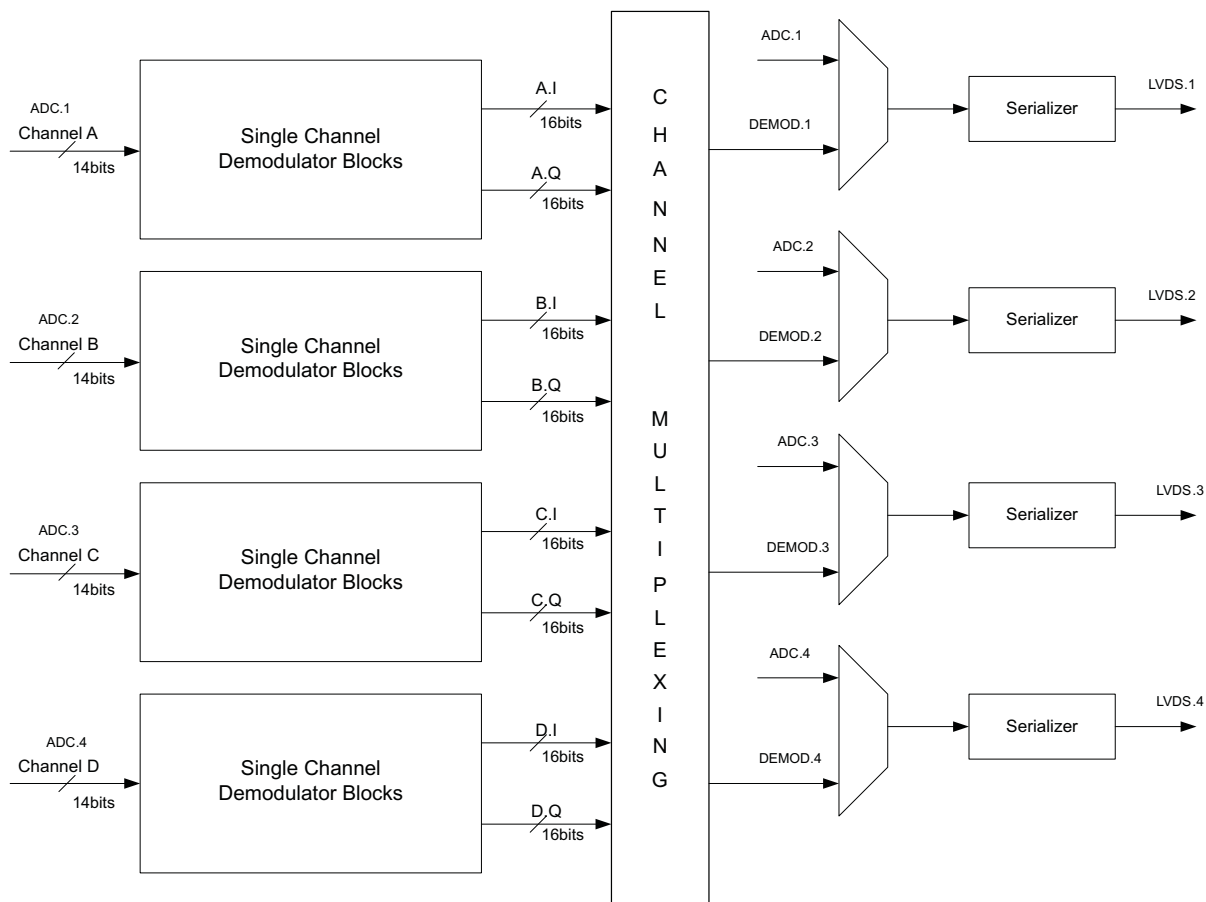

Figure 76. Channel Multiplexing

8.3.7 Equivalent Circuits

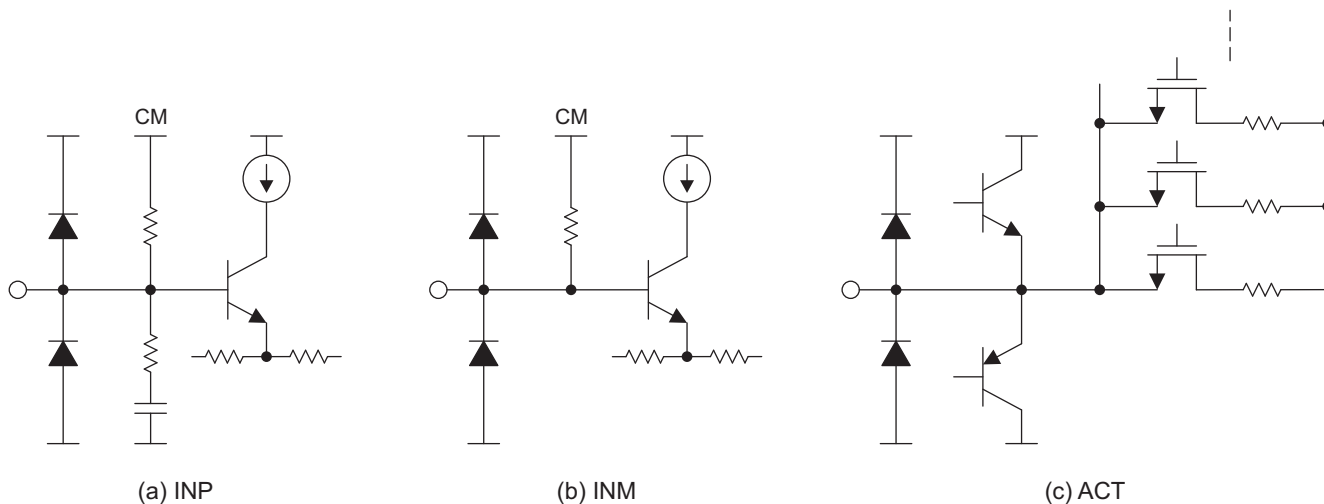
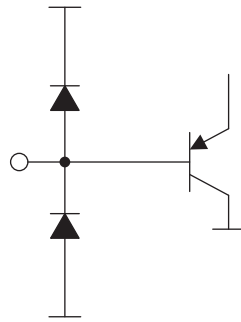

Figure 77. Equivalent Circuits of LNA Inputs

S0492-01



S0493-01

**Figure 78. Equivalent Circuits of  $V_{CNTLP/M}$**

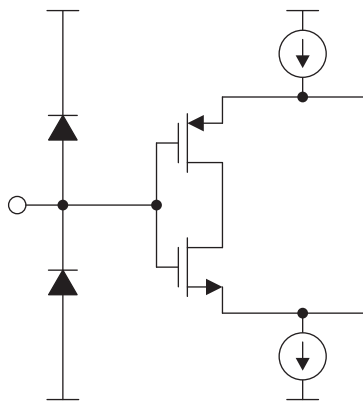

(a) CW 1X and 16X Clocks

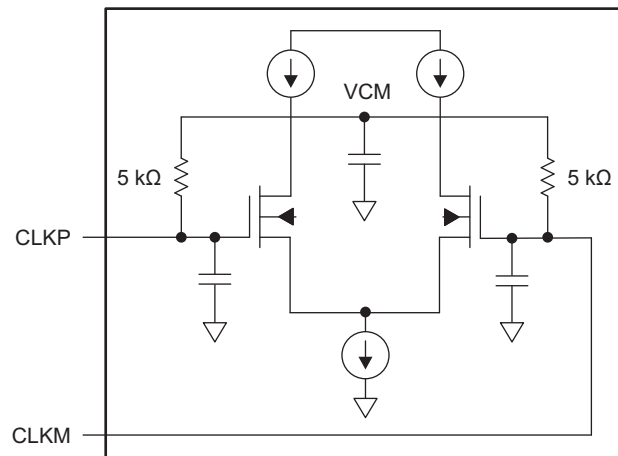

(b) ADC Input Clocks

S0494-01

**Figure 79. Equivalent Circuits of Clock Inputs**

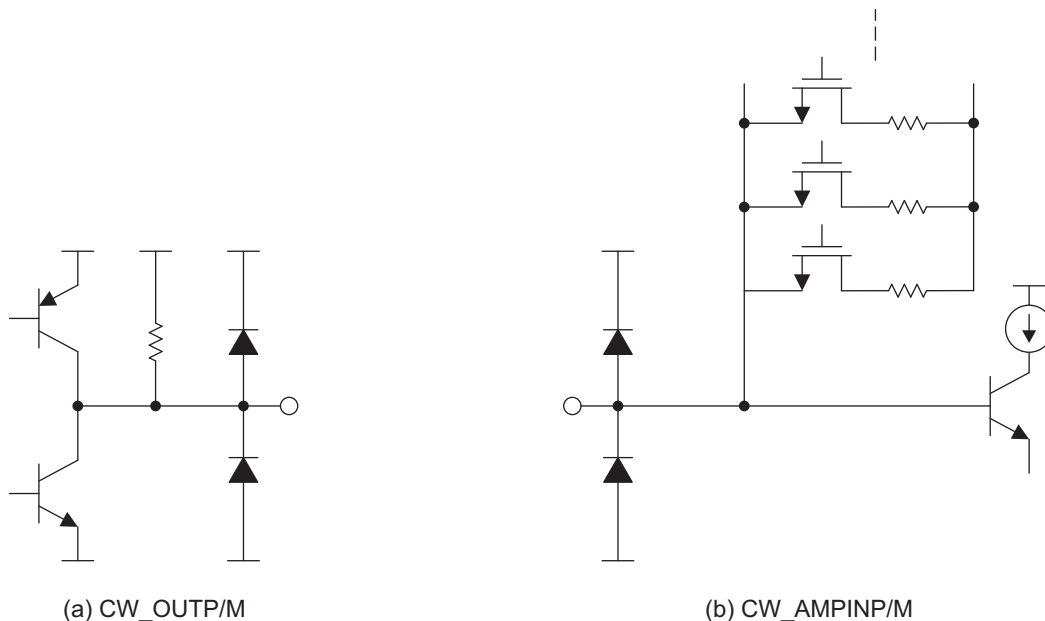

S0495-01

Figure 80. Equivalent Circuits of CW Summing Amplifier Inputs and Outputs

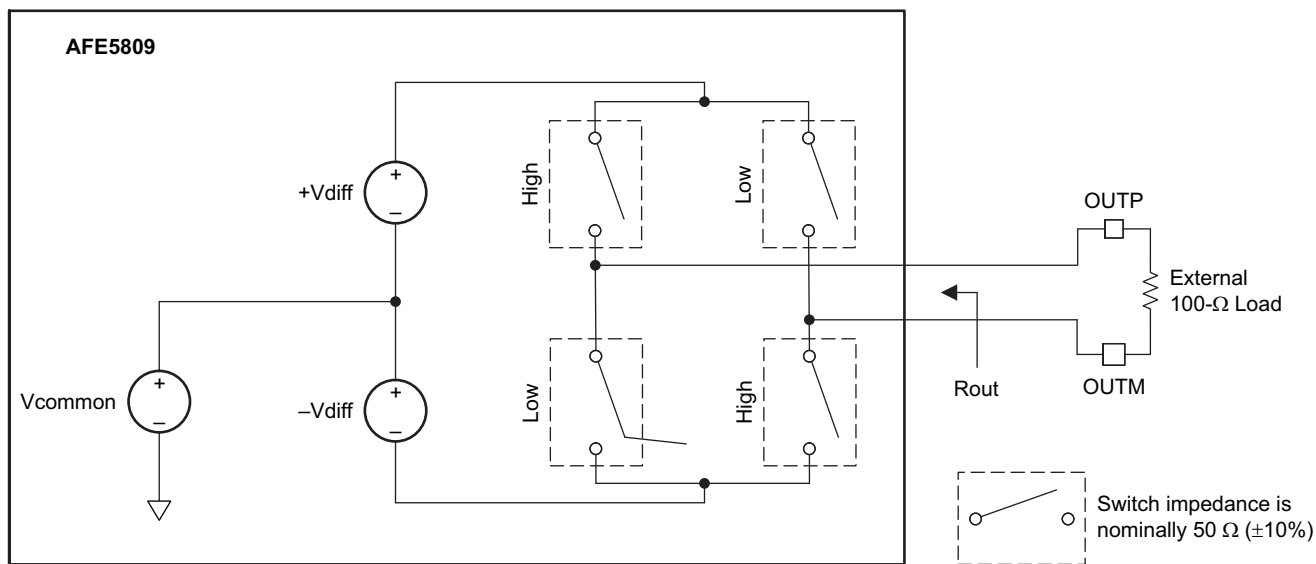

Figure 81. Equivalent Circuits of LVDS Outputs

### 8.3.8 LVDS Output Interface Description

The AFE5809 device has a LVDS output interface, which supports multiple output formats. The ADC resolutions can be configured as 12 bit or 14 bit as shown in the LVDS timing diagrams (Figure 1). The ADCs in the AFE5809 device are running at 14 bits; 2 LSBs are removed when 12-bit output is selected; and two zeros are added at LSBs when 16-bit output is selected. Appropriate ADC resolutions can be selected for optimizing system-performance cost effectiveness. When the devices run at 16-bit mode, higher-end FPGAs are required to process the higher rate of LVDS data. Corresponding register settings are listed in Table 4.

## 8.4 Device Functional Modes

The AFE5809 device is a highly-integrated AFE solution. The AFE5809 device has two functional modes: pulsed-wave imaging mode and continuous-wave Doppler imaging mode. When the AFE5809 device operates in the pulsed-wave imaging mode, LNA, VCAT, PGA, LPF, 14-bit ADC, and digital I/Q demodulator are active. In the CWD imaging mode, only LNA and CW mixer are enabled. Either mode can be enabled or programmed by the registers described below.

## 8.5 Programming

### 8.5.1 Serial Peripheral Interface (SPI) Operation

The AFE5809 device has two SPIs. The demodulator SPI interface is independent from the ADC/VCA SPI as shown in [Figure 82](#). SPI\_DIG\_EN is used to select ADC/VCA SPI (SPI\_DIG\_EN='1') or demod SPI (SPI\_DIG\_EN='0').

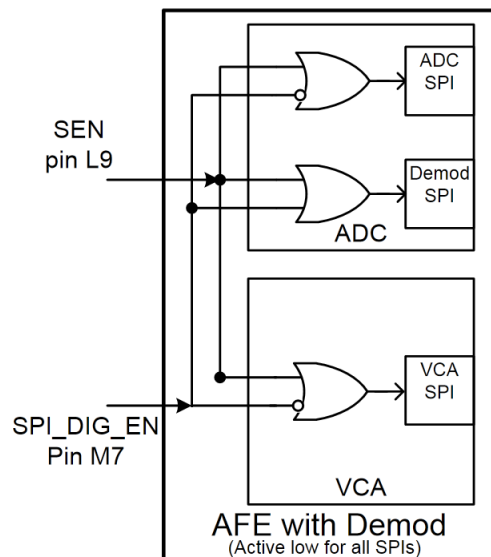

**Figure 82. SPI Interface in the AFE5809 Device**

#### 8.5.1.1 ADC/VCA Serial Register Write Description

Programming of different modes can be done through the serial interface formed by pins SEN (serial interface enable), SCLK (serial interface clock), SDATA (serial interface data), and RESET. All these pins have a pulldown resistor to GND of 20 kΩ. Serial shift of bits into the device is enabled when SEN is low. Serial data, SDATA, is latched at every rising edge of SCLK when SEN is active (low). The serial data is loaded into the register at every 24<sup>th</sup> SCLK rising edge when SEN is low. If the word length exceeds a multiple of 24 bits, the excess bits are ignored. Data can be loaded in multiple of 24-bit words within a single active SEN pulse (an internal counter counts groups of 24 clocks after the falling edge of SEN). The interface can work with the SCLK frequency from 20 MHz to low speeds (of a few Hertz) and even with non-50% duty cycle SCLK. The data is divided into two main portions: a register address (8 bits) and the data itself (16 bits), to load on the addressed register. When writing to a register with unused bits, set these to 0. [Figure 83](#) shows this process.

Programming (continued)

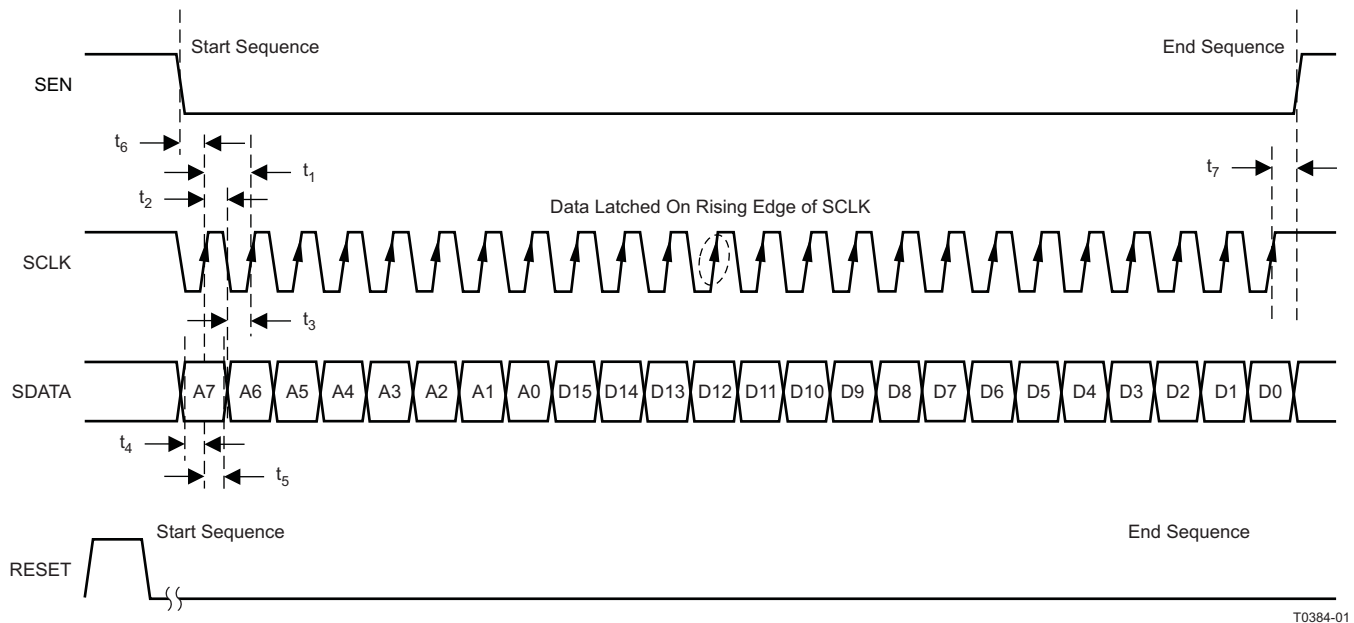

Figure 83. SPI Timing

NOTE

TI recommends synchronizing SCLK to ADC CLK. Typically, SCLK can be generated by dividing ADC CLK by an integer factor of N. In a system with multiple AFEs, SCLKs may not reach all AFEs simultaneously due to routing. To compensate routing differences and ensure AFEs' outputs are aligned, SCLK can be adjusted to toggle on either the falling edge of ADCLK or the rising edge of ADC CLK (ensuring new register settings are loaded before next ADC sampling clock).

8.5.1.2 ADC/VCA Serial Register Readout Description

The device includes an option where the contents of the internal registers can be read back. This may be useful as a diagnostic test to verify the serial interface communication between the external controller and the AFE. First, the <REGISTER READOUT ENABLE> bit (Reg0[1]) needs to be set to 1. Then, the user should initiate a serial interface cycle specifying the address of the register (A7 through A0) whose content must be read. The data bits are don't care. The device outputs the contents (D15 through D0) of the selected register on the SDOUT pin. SDOUT has a typical delay,  $t_8$ , of 20 ns from the falling edge of the SCLK. For lower speed SCLK, SDOUT can be latched on the rising edge of SCLK. For higher speed SCLK, for example, if the SCLK period is less than 60 ns, it is better to latch the SDOUT at the next falling edge of SCLK. Figure 84 shows this operation (the timing specifications follow the same information provided). In the readout mode, users still can access the <REGISTER READOUT ENABLE> through SDATA/SCLK/SEN. To enable serial register writes, set the <REGISTER READOUT ENABLE> bit back to 0.

The AFE5809 SDOUT buffer is tri-stated and gets enabled only when 0[1] (REGISTER READOUT ENABLE) is enabled. SDOUT pins from multiple AFE5809 devices can be tied together without any pullup resistors. Level shifter SN74AUP1T04 can be used to convert 1.8-V logic to 2.5-V/3.3-V logics if needed.

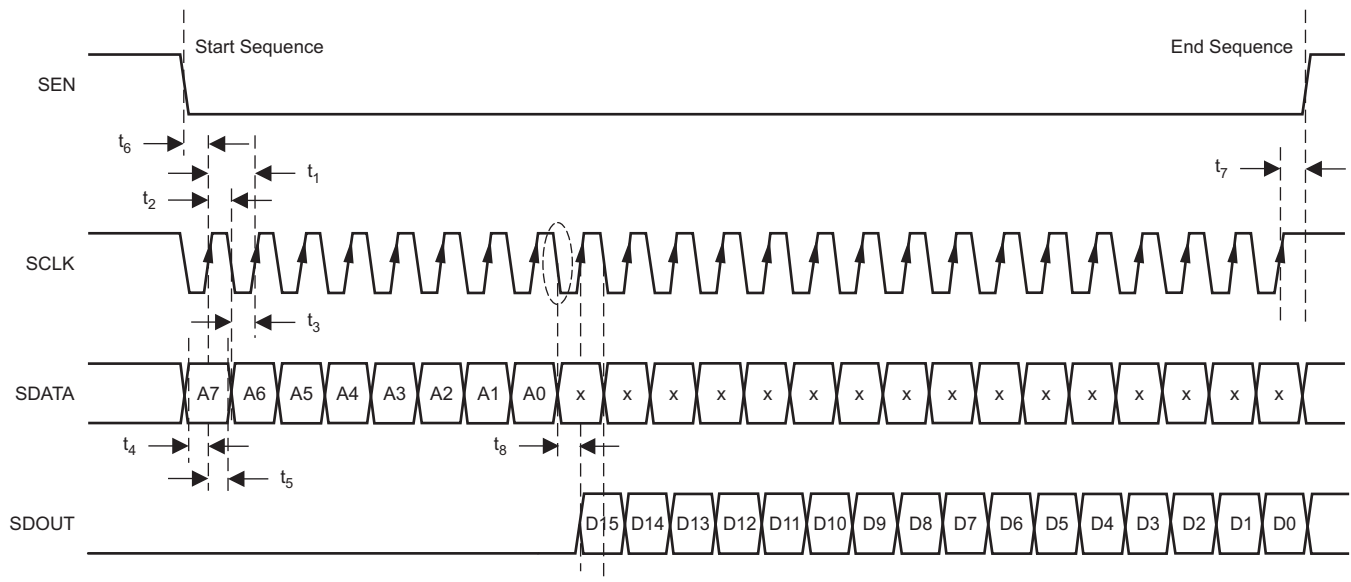
**Programming (continued)**

**Figure 84. Serial Interface Register Read**
**8.5.1.3 Digital Demodulator SPI Description**

Demodulator is enabled after a software or hardware reset. It can be disabled by setting the LSB of register 0x16 as 1. This is done using the ADC SPI interface, that is,  $SPI\_DIG\_EN = 1$ .

To access the specific demodulator registers:

1.  $SPI\_DIG\_EN$  pin is required to be set as 0 during SPI transactions to demodulator registers. Meanwhile, ADC SEN needs to be set as 0 during demodulator SPI programming.
2. The SPI register address is 8 bits and is made of 2 subchip select bits and 6 register address bits. SPI register data is 16 bits.

**Table 2. Register Address Bit Description**

Bit7	Bit6	Bit 5:0
SCID1_SEL	SCID0_SEL	Register address <5:0>

3. SCID0\_SEL enables configuration of channels 1 through 4. SCID1\_SEL enables configuration of channels 5 through 8. When performing demodulator SPI write transactions, these SCID bits can be individually or mutually used with a specific register address.
4. Register configuration is normally shared by both subchips (both SCID bits should be set as 1). An exception to this rule would be the DC OFFSET registers (0x14 through 0x17) for which specific channel access is expected.

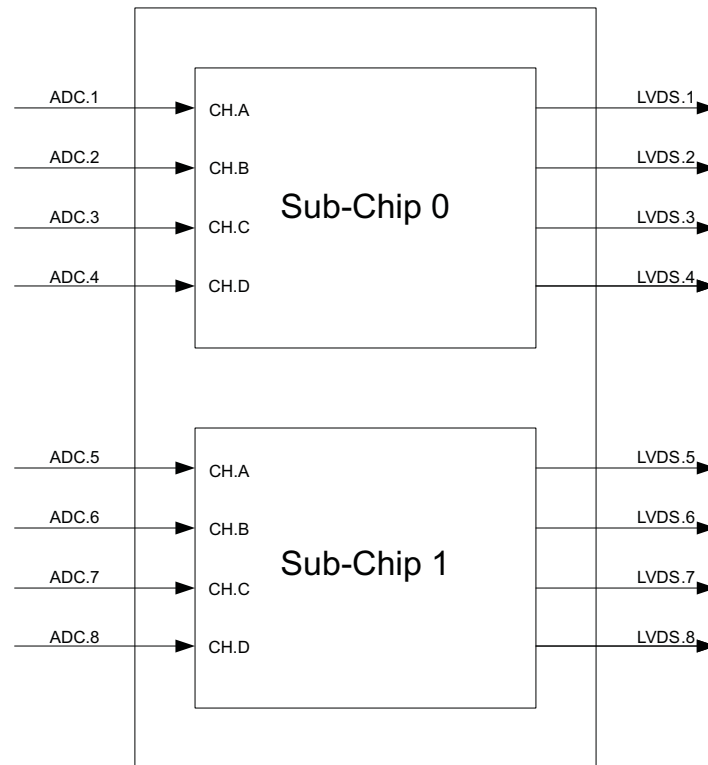

- A. Each of two subchips supports four channels.
- B. Each of two demodulators has four channels named as A, B, C, and D.

**Figure 85. Demod Subchip 0 and Subchip 1**

5. Demodulator register readout follows these procedures:

- Write 1 to register 0x0[1]; pin SPI\_DIG\_EN should be 0 while writing. This is the readout enable register for demodulator.
- Write 1 to register 0x0[1]; pin SPI\_DIG\_EN should be 1 while writing. This is the readout enable register for ADC and VCA.
- Set SPI\_DIG\_EN as 0 and write anything to the register whose stored data needs to be known. Device finds the address of the register and sends its stored data at the SDOUT pin serially.

**NOTE**

After enabling the register 0x0[1] REGISTER\_READOUT\_ENABLE, data cannot be written to the register (whose data needs to be known), but stored data would come serially at the SDOUT pin.

- To disable the register readout, first write 0 to register 0x0[1] while SPI\_DIG\_EN is 1; then write 0 to register 0x0[1] while SPI\_DIG\_EN is 0.

## 8.6 Register Maps

### 8.6.1 ADC and VCA Register Description

A reset process is required at the AFE5809 device's initialization stage. Initialization can be done in one of two ways:

- Through a hardware reset, by applying a positive pulse in the RESET pin.
- Through a software reset, using the serial interface, by setting the SOFTWARE RESET bit to high. Setting this bit initializes the internal registers to the respective default values (all zeros), and then self-resets the SOFTWARE RESET bit to low. In this case, the RESET pin can stay low (inactive).

After reset, all ADC and VCA registers are set to 0, that is default setting. During register programming, all unlisted register bits must be set as 0.

Some demodulator registers are set as 1 after reset. During register programming, all unlisted register bits must be set as 0. In addition, the demodulator registers can be reset when 0x16[0] is set as 0. Thus, it is required to reconfigure the demodulator registers after toggling the 0x16[0] from 1 to 0.

#### 8.6.1.1 ADC Register Map

Address (DEC)	Address (HEX)	Default Value	Function	Description
0[0]	0x0[0]	0	SOFTWARE_RESET	0: Normal operation 1: Resets the device and self-clears the bit to 0. Note: Register 0 is a write only register.
0[1]	0x0[1]	0	REGISTER_READOUT_ENABLE	0: Disables readout 1: Enables readout of register at SDO pin. Note: When this bit is set to 0, the device always operates in write mode and when it is set to 1, device will be in read mode. Multiple reading or writing events can be performed when this bit is set to 1 or 0 correspondingly. Register 0 is a write-only register.
1[0]	0x1[0]	0	ADC_COMPLETE_PDN	0: Normal 1: Complete power down. <b>Note:</b> When the complete power-down mode is enabled, the digital demodulator may lose register settings. Therefore, it is required to reconfigure the demodulator registers, filter coefficient memory, and profile memory after exiting the complete power-down mode.
1[1]	0x1[1]	0	LVDS_OUTPUT_DISABLE	0: Output enabled 1: Output disabled
1[9:2]	0x1[9:2]	0	ADC_PDN_CH<7:0>	0: Normal operation 1: Power down. Power down individual ADC channels. 1[9] → CH8...1[2] → CH1
1[10]	0x1[10]	0	PARTIAL_PDN	0: Normal operation 1: Partial power down ADC
1[11]	0x1[11]	0	LOW_FREQUENCY_NOISE_SUPPRESSION	0: No suppression 1: Suppression enabled
1[13]	0x1[13]	0	EXT_REF	0: Internal reference 1: External reference. VREF_IN is used. Both 3[15] and 1[13] should be set as 1 in the external reference mode
1[14]	0x1[14]	0	LVDS_OUTPUT_RATE_2X	0: 1x rate 1: 2x rate. Combines data from 2 channels on 1 LVDS pair. When ADC clock rate is low, this feature can be used.
1[15]	0x1[15]	0	SINGLE-ENDED_CLK_MODE	0: Differential clock input 1: Single-ended clock input
2[2:0]	0x2[2:0]	0	RESERVED	Set to 0
2[10:3]	0x2[10:3]	0	POWER-DOWN_LVDS	0: Normal operation 1: PDN individual LVDS outputs. 2[10] → CH8...2[3] → CH1
2[11]	0x2[11]	0	AVERAGING_ENABLE	0: No averaging 1: Average two channels to increase SNR
2[12]	0x2[12]	0	LOW_LATENCY	0: Default latency with digital features supported 1: Low latency with digital features bypassed

**Register Maps (continued)**

Address (DEC)	Address (HEX)	Default Value	Function	Description
2[15:13]	0x2[15:13]	0	TEST_PATTERN_MODES	000: Normal operation 001: Sync 010: De-skew 011: Custom 100: All 1's 101: Toggle 110: All 0's 111: Ramp
3[7:0]	0x3[7:0]	0	INVERT_CHANNELS	0: No inverting 1: Invert channel digital output. 3[7] → CH8;3[0] → CH1. Note: Suppose that the device is giving digital output of 11001100001111. After enabling this bit, output of device becomes 00110011110000. Note: This function is not applicable for ADC test patterns and in demod mode.
3[8]	0x3[8]	0	CHANNEL_OFFSET_SUBTRACTION_ENABLE	0: No offset subtraction 1: Offset value subtract enabled
3[9:11]	0x3[9:11]	0	RESERVED	Set to 0
3[12]	0x3[12]	0	DIGITAL_GAIN_ENABLE	0: No digital gain 1: Digital gain enabled
3[14:13]	0x3[14:13]	0	SERIALIZED_DATA_RATE	Serialization factor 00: 14x 01: 16x 10: Reserved 11: 12x When 4[1] = 1, in the 16x serialization rate, two zeros are filled at two LSBs (see Table 4). <b>Note:</b> Make sure the settings aligning with the demod register 0x3[14:13]. Be aware that the same setting, for example, 00, in these two registers can represent different LVDS data rates respectively.
3[15]	0x3[15]	0	ENABLE_EXTERNAL_REFERENCE_MODE	0: Internal reference mode 1: Set to external reference mode <b>Note:</b> Both 3[15] and 1[13] should be set as 1 when configuring the device in the external reference mode.
4[1]	0x4[1]	0	ADC_RESOLUTION_SELECT	0: 14 bit 1: 12 bit
4[3]	0x4[3]	0	ADC_OUTPUT_FORMAT	0: 2's complement 1: Offset binary <b>Note: When the demodulation feature is enabled, only 2's complement format can be selected.</b>
4[4]	0x4[4]	0	LSB_MSB_FIRST	0: LSB first 1: MSB first
5[13:0]	0x5[13:0]	0	CUSTOM_PATTERN	Custom pattern data for LVDS output (2[15:13] = 011)
10[8]	0xA[8]	0	SYNC_PATTERN	0: Test pattern outputs of 8 channels are not synchronized. 1: Test pattern outputs of 8 channels are synchronized.
13[9:0]	0xD[9:0]	0	OFFSET_CH1	Value to be subtracted from channel 1 code
13[15:11]	0xD[15:11]	0	DIGITAL_GAIN_CH1	0 to 6 dB in 0.2-dB steps
15[9:0]	0xF[9:0]	0	OFFSET_CH2	Value to be subtracted from channel 2 code
15[15:11]	0xF[15:11]	0	DIGITAL_GAIN_CH2	0 to 6 dB in 0.2-dB steps
17[9:0]	0x11[9:0]	0	OFFSET_CH3	Value to be subtracted from channel 3 code
17[15:11]	0x11[15:11]	0	DIGITAL_GAIN_CH3	0 to 6 dB in 0.2-dB steps
19[9:0]	0x13[9:0]	0	OFFSET_CH4	Value to be subtracted from channel 4 code
19[15:11]	0x13[15:11]	0	DIGITAL_GAIN_CH4	0 to 6 dB in 0.2-dB steps
21[0]	0x15[0]	0	DIGITAL_HPF_FILTER_ENABLE_CH1-4	0: Disable the digital HPF filter; 1: Enable for 1 to 4 channels <b>Note:</b> This HPF feature is only available when the demodulation block is disabled.
21[4:1]	0x15[4:1]	0	DIGITAL_HPF_FILTER_K_CH1-4	Set K for the HPF (k from 2 to 10, that is 0010B to 1010B). This group of four registers controls the characteristics of a digital high-pass transfer function applied to the output data, following the formula: $y(n) = 2^k / (2^k + 1) [x(n) - x(n-1) + y(n-1)]$ (see Table 3)

**Register Maps (continued)**

Address (DEC)	Address (HEX)	Default Value	Function	Description
22[0]	0x16[0]	0	EN_DEMOD	0: Digital demodulator is enabled 1: Digital demodulator is disabled <b>Note:</b> The demodulator registers can be reset when 0x16[0] is set as 0. Thus, it is required to reconfigure the demodulator registers after toggling the 0x16[0].
25[9:0]	0x19[9:0]	0	OFFSET_CH8	Value to be subtracted from channel 8 code
25[15:11]	0x19[15:11]	0	DIGITAL_GAIN_CH8	0 to 6-dB in 0.2-dB steps
27[9:0]	0x1B[9:0]	0	OFFSET_CH7	Value to be subtracted from channel 7 code
27[15:11]	0x1B[15:11]	0	DIGITAL_GAIN_CH7	0 to 6-dB in 0.2-dB steps
29[9:0]	0x1D[9:0]	0	OFFSET_CH6	Value to be subtracted from channel 6 code
29[15:11]	0x1D[15:11]	0	DIGITAL_GAIN_CH6	0 to 6-dB in 0.2-dB steps
31[9:0]	0x1F[9:0]	0	OFFSET_CH5	Value to be subtracted from channel 5 code
31[15:11]	0x1F[15:11]	0	DIGITAL_GAIN_CH5	0 to 6-dB in 0.2-dB steps
33[0]	0x21[0]	0	DIGITAL_HPF_FILTER_ENABLE_CH5-8	0: Disable the digital HPF filter 1: Enable for 5 to 8 channels <b>Note:</b> This HPF feature is only available when the demodulation block is disabled.
33[4:1]	0x21[4:1]	0	DIGITAL_HPF_FILTER_K_CH5-8	Set K for the HPF (k from 2 to 10, 0010B to 1010B) This group of four registers controls the characteristics of a digital high-pass transfer function applied to the output data, following the formula: $y(n) = 2^k / (2^k + 1) [x(n) - x(n - 1) + y(n - 1)]$ (see <a href="#">Table 3</a> )

**8.6.1.2 AFE5809 ADC Register/Digital Processing Description**

The ADC in the AFE5809 device has extensive digital processing functionality, which can be used to enhance ultrasound system performance. The digital processing blocks are arranged as in [Figure 86](#).

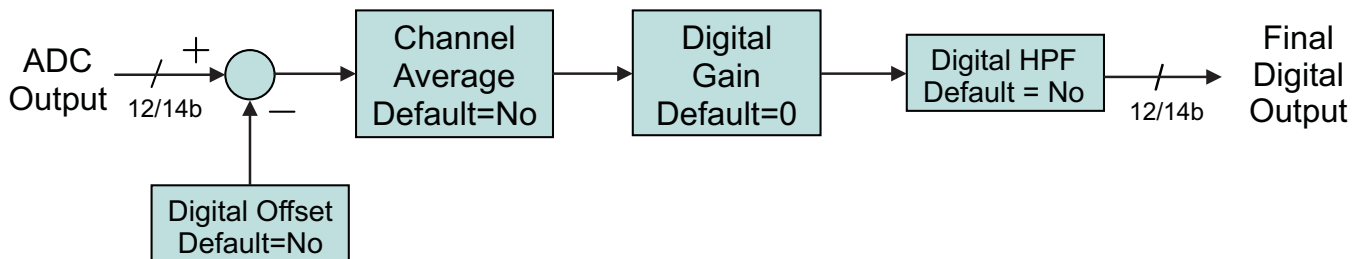

**Figure 86. ADC Digital Block Diagram**

**NOTE**

These digital processing features are only available when the demodulation block is disabled. ADC output data directly enter the digital demodulator when the demod is enabled.

**8.6.1.2.1 AVERAGING\_ENABLE: Address: 2[11]**

When set to 1, two samples, corresponding to two consecutive channels, are averaged (channel 1 with 2, 3 with 4, 5 with 6, and 7 with 8). If both channels receive the same input, the net effect is an improvement in SNR. The averaging is performed as:

- Channel 1 + channel 2 comes out on channel 3
- Channel 3 + channel 4 comes out on channel 4
- Channel 5 + channel 6 comes out on channel 5
- Channel 7 + channel 8 comes out on channel 6

**8.6.1.2.2 ADC\_OUTPUT\_FORMAT: Address: 4[3]**

The ADC output, by default, is in 2's-complement mode. Programming the ADC\_OUTPUT\_FORMAT bit to 1 inverts the MSB, and the output becomes straight-offset binary mode.

---

**NOTE**

When the demodulation feature is enabled, only 2's complement format can be selected.

---

**8.6.1.2.3 ADC Reference Mode: Address 1[13] and 3[15]**

The following shows the register settings for the ADC internal reference mode and external reference mode.

- 0x1[13] 0x3[15] = 00: ADC internal reference mode, VREF\_IN floating (pin M3)
- 0x1[13] 0x3[15] = 01: N/A
- 0x1[13] 0x3[15] = 10: N/A
- 0x1[13] 0x3[15] = 11: ADC external reference mode, VREF\_IN = 1.4 V (pin M3)

**8.6.1.2.4 DIGITAL\_GAIN\_ENABLE: Address: 3[12]**

Setting this bit to 1 applies to each channel *i* the corresponding gain given by DIGITAL\_GAIN\_CHi <15:11>. The gain is given as 0 dB + 0.2 dB × DIGITAL\_GAIN\_CHi<15:11>. For instance, if DIGITAL\_GAIN\_CH5<15:11> = 3, channel 5 is increased by 0.6-dB gain. DIGITAL\_GAIN\_CHi <15:11> = 31 produces the same effect as DIGITAL\_GAIN\_CHi <15:11> = 30, setting the gain of channel *i* to 6 dB.

**8.6.1.2.5 DIGITAL\_HPF\_ENABLE**

- CH1 to CH4: Address 21[0]
- CH5 to CH8: Address 33[0]

**8.6.1.2.6 DIGITAL\_HPF\_FILTER\_K\_CHX**

- CH1 to CH4: Address 21[4:1]
- CH5 to CH8: Address 33[4:1]

This group of registers controls the characteristics of a digital high-pass transfer function applied to the output data, following [Equation 4](#).

$$y(n) = \frac{2^k}{2^k + 1} [x(n) - x(n-1) + y(n-1)] \quad (4)$$

These digital HPF registers (one for the first four channels and one for the second group of four channels) describe the setting of *K*. The digital HPF can be used to suppress low frequency noise, which commonly exists in ultrasound echo signals. The digital filter can significantly benefit near-field recovery time due to T/R switch low-frequency response. [Table 3](#) shows the cut-off frequency versus *K*.

**Table 3. Digital HPF –1-dB Corner Frequency versus *K* and *F<sub>s</sub>***

<b>k</b>	<b>40 MSPS</b>	<b>50 MSPS</b>	<b>65 MSPS</b>
2	2780 kHz	3480 kHz	4520 kHz
3	1490 kHz	1860 kHz	2420 kHz
4	770 kHz	960 kHz	1250 kHz

**8.6.1.2.7 LOW\_FREQUENCY\_NOISE\_SUPPRESSION: Address: 1[11]**

The low-frequency noise suppression mode is especially useful in applications where good noise performance is desired in the frequency band of 0 to 1 MHz (around DC). Setting this mode shifts the low-frequency noise of the AFE5809 device to approximately *F<sub>s</sub>* / 2, thereby moving the noise floor around DC to a much lower value. Register bit 1[11] is used for enabling or disabling this feature. When this feature is enabled, power consumption of the device is increased slightly by approximately 1 mW/CH.

**8.6.1.2.8 LVDS\_OUTPUT\_RATE\_2X: Address: 1[14]**

The output data always uses a DDR format, with valid/different bits on the positive as well as the negative edges of the LVDS bit clock, DCLK. The output rate is set by default to 1x (LVDS\_OUTPUT\_RATE\_2X = 0), where each ADC has one LVDS stream associated with it. If the sampling rate is low enough, two ADCs can share one LVDS stream, in this way lowering the power consumption devoted to the interface. The unused outputs will output zero. To avoid consumption from those outputs, no termination should be connected to them. The distribution on the used output pairs is done in the following way:

- Channel 1 and channel 2 come out on channel 3. Channel 1 comes out first.
- Channel 3 and channel 4 come out on channel 4. Channel 3 comes out first.
- Channel 5 and channel 6 come out on channel 5. Channel 5 comes out first.
- Channel 7 and channel 8 come out on channel 6. Channel 7 comes out first.

**8.6.1.2.9 CHANNEL\_OFFSET\_SUBTRACTION\_ENABLE: Address: 3[8]**

Setting this bit to 1 enables the subtraction of the value on the corresponding OFFSET\_CHx<9:0> (offset for channel i) from the ADC output. The number is specified in 2's complement format. For example, OFFSET\_CHx<9:0> = 11 1000 0000 means subtract -128. For OFFSET\_CHx<9:0> = 00 0111 1111 the effect is to subtract 127. In effect, both addition and subtraction can be performed. The offset is applied before the digital gain (see DIGITAL\_GAIN\_ENABLE). The whole data path is 2's complement throughout internally, with digital gain being the last step. Only when ADC\_OUTPUT\_FORMAT = 1 (straight binary output format) is the 2's complement word translated into offset binary at the end.

**8.6.1.2.10 SERIALIZED\_DATA\_RATE: Address: 3[14:13]**

See [Table 4](#) for detailed description.

**Table 4. Corresponding Register Settings**

LVDS Rate	12 bit (6x DCLK)	14 bit (7x DCLK)	16 bit (8x DCLK)
Register 3 [14:13]	11	00	01
Register 4 [2:0]	010	000	000
Description	2 LSBs removed	N/A	2 zeroes added at LSBs

**8.6.1.2.11 TEST\_PATTERN\_MODES: Address: 2[15:13]**

The AFE5809 device can output a variety of test patterns on the LVDS outputs. These test patterns replace the normal ADC data output. The device may also be made to output 6 preset patterns:

- Ramp: Setting Register 2[15:13] = 111 causes all the channels to output a repeating full-scale ramp pattern. The ramp increments from zero code to full-scale code in steps of 1 LSB every clock cycle. After hitting the full-scale code, it returns back to zero code and ramps again.
- Zeros: The device can be programmed to output all 0 s by setting Register 2[15:13] = 110.
- Ones: The device can be programmed to output all 1 s by setting Register 2[15:13] = 100.
- Deskew Patten: When 2[15:13] = 010; this mode replaces the 14-bit ADC output with the 01010101010101 word.
- Sync Pattern: When 2[15:13] = 001, the normal ADC output is replaced by a fixed 1111111100000000 word.
- Toggle: When 2[15:13] = 101, the normal ADC output is alternating from 1 s to 0 s. The start state of ADC word can be either 1 s or 0 s.
- Custom Pattern: It can be enabled when 2[15:13] = 011. Users can write the required VALUE into register bits <CUSTOM PATTERN>, which is Register 5[13:0]. Then, the device will output VALUE at its outputs, about 3 to 4 ADC clock cycles after the 24<sup>th</sup> rising edge of SCLK. So, the time taken to write one value is 24 SCLK clock cycles + 4 ADC clock cycles. To change the customer pattern value, users can repeat writing Register 5[13:0] with a new value. Due to the speed limit of SPI, the refresh rate of the custom pattern may not be high. For example, 128 points custom pattern takes approximately 128 × (24 SCLK clock cycles + 4 ADC clock cycles).

**NOTE**

Only one of the above patterns can be active at any given instant. Test pattern from the ADC output stage can NOT be sent to the demodulator; it can only be sent to the LVDS serializer when the demodulator is off.

**8.6.1.2.12 SYNC\_PATTERN: Address: 10[8]**

By enabling this bit, all channels' test pattern outputs are synchronized. When 10[8] is set as 1, the ramp patterns of all 8 channels start simultaneously.

**8.6.1.3 VCA Register Map**

Address (DEC)	Address (HEX)	Default Value	Function	Description
51[0]	0x33[0]	0	RESERVED	0
51[3:1]	0x33[3:1]	0	LPF_PROGRAMMABILITY	000: 15 MHz 010: 20 MHz 011: 30 MHz 100: 10 MHz <b>Note:</b> 0x3D[14], that is, 5 MHz LPF, should be set as 0.
51[4]	0x33[4]	0	PGA_INTEGRATOR_DISABLE (PGA_HPF_DISABLE)	0: Enable 1: Disable offset integrator for PGA. See the explanation for the PGA integrator function in the <a href="#">Application Information</a> section
51[7:5]	0x33[7:5]	0	PGA_CLAMP_LEVEL	Low-noise mode; 53[11:10] = 00 000: -2 dBFS 010: 0 dBFS 1XX: Clamp is disabled Low-power/medium-power mode; 53[11:10] = 01/10 100: -2 dBFS 110: 0 dBFS 0XX: clamp is disabled <b>Note:</b> The clamp circuit makes sure that PGA output is in linear range. For example, at 000 setting, PGA output HD3 will worsen by 3 dB at -2-dBFS ADC input. In normal operation, clamp function can be set as 000 in the low-noise mode. The maximum PGA output level can exceed 2Vpp with the clamp circuit enabled. <b>Note:</b> In the low-power and medium-power modes, PGA_CLAMP is disabled for saving power if 51[7] = 0. <b>Note:</b> Register 61[15] should be set as 0; otherwise, PGA_CLAMP_LEVEL is affected by Register 61[15].
51[13]	0x33[13]	0	PGA_GAIN_CONTROL	0:24 dB 1:30 dB
52[4:0]	0x34[4:0]	0	ACTIVE_TERMINATION_INDIVIDUAL_RESISTOR_CNTL	See <a href="#">Table 6</a> . Register 52[5] should be set as 1 to access these bits
52[5]	0x34[5]	0	ACTIVE_TERMINATION_INDIVIDUAL_RESISTOR_ENABLE	0: Disable 1: Enable internal active termination individual resistor control
52[7:6]	0x34[7:6]	0	PRESET_ACTIVE_TERMINATIONS	00: 50 Ω 01: 100 Ω 10: 200 Ω 11: 400 Ω <b>Note:</b> The device adjusts resistor mapping (52[4:0]) automatically. 50-Ω active termination is not supported in 12-dB LNA setting. Instead, 00 represents high-impedance mode when LNA gain is 12 dB.

Address (DEC)	Address (HEX)	Default Value	Function	Description
52[8]	0x34[8]	0	ACTIVE_TERMINATION_ENABLE	0: Disable 1: Enable active termination
52[10:9]	0x34[10:9]	0	LNA_INPUT_CLAMP_SETTING	00: Auto setting 01: 1.5 Vpp 10: 1.15 Vpp 11: 0.6 Vpp
52[11]	0x34[11]	0	RESERVED	Set to 0
52[12]	0x34[12]	0	LNA_INTEGRATOR_DISABLE (LNA_HPF_DISABLE)	0: Enable 1: Disable offset integrator for LNA. See the explanation for this function in the following section
52[14:13]	0x34[14:13]	0	LNA_GAIN	00: 18 dB 01: 24 dB 10: 12 dB 11: Reserved
52[15]	0x34[15]	0	LNA_INDIVIDUAL_CH_CNTL	0: Disable 1: Enable LNA individual channel control. See Register 57 for details
53[7:0]	0x35[7:0]	0	PDN_CH<7:0>	0: Normal operation 1: Powers down corresponding channels. Bit7 → CH8, Bit6 → CH7...Bit0 → CH1. PDN_CH shuts down whichever blocks are active depending on TGC mode or CW mode.
53[8]	0x35[8]	0	RESERVED	Set to 0
53[9]	0x35[9]	0	LOW_NF	0: Normal operation 1: Enable low-noise figure mode for high-impedance probes
53[11:10]	0x35[11:10]	0	POWER_MODES	00: Low noise mode 01: Set to low-power mode. At 30-dB PGA, total chain gain may slightly change. See <i>Typical Characteristics</i> . 10: Set to medium-power mode. At 30-dB PGA, total chain gain may slightly change. See <i>Typical Characteristics</i> . 11: Reserved
53[12]	0x35[12]	0	PDN_VCAT_PGA	0: Normal operation 1: Powers down VCAT and PGA
53[13]	0x35[13]	0	PDN_LNA	0: Normal operation 1: Powers down LNA only
53[14]	0x35[14]	0	VCA_PARTIAL_PDN	0: Normal operation 1: Powers down LNA, VCAT, and PGA partially (fast-wake response)
53[15]	0x35[15]	0	VCA_COMPLETE_PDN	0: Normal operation 1: Power down LNA, VCAT, and PGA completely (slow-wake response). This bit can overwrite 53[14].
54[4:0]	0x36[4:0]	0	CW_SUM_AMP_GAIN_CNTL	Select feedback resistor for the CW amplifier as per <a href="#">Table 6</a>
54[5]	0x36[5]	0	CW_16X_CLK_SEL	0: Accept differential clock 1: Accept CMOS clock
54[6]	0x36[6]	0	CW_1X_CLK_SEL	0: Accept CMOS clock 1: Accept differential clock
54[7]	0x36[7]	0	RESERVED	Set to 0
54[8]	0x36[8]	0	CW_TGC_SEL	0: TGC mode 1 : CW mode Note : VCAT and PGA are still working in CW mode. They should be powered down separately through 53[12].

Address (DEC)	Address (HEX)	Default Value	Function	Description
54[9]	0x36[9]	0	CW_SUM_AMP_ENABLE	0: Enable CW summing amplifier 1: Disable CW summing amplifier <b>Note:</b> 54[9] is only effective in CW mode.
54[11:10]	0x36[11:10]	0	CW_CLK_MODE_SEL	00: 16x mode 01: 8x mode 10: 4x mode 11: 1x mode
55[3:0]	0x37[3:0]	0	CH1_CW_MIXER_PHASE	0000 → 1111, 16 different phase delays, see <a href="#">Table 10</a>
55[7:4]	0x37[7:4]	0	CH2_CW_MIXER_PHASE	
55[11:8]	0x37[11:8]	0	CH3_CW_MIXER_PHASE	
55[15:12]	0x37[15:12]	0	CH4_CW_MIXER_PHASE	
56[3:0]	0x38[3:0]	0	CH5_CW_MIXER_PHASE	
56[7:4]	0x38[7:4]	0	CH6_CW_MIXER_PHASE	
56[11:8]	0x38[11:8]	0	CH7_CW_MIXER_PHASE	
56[15:12]	0x38[15:12]	0	CH8_CW_MIXER_PHASE	
57[1:0]	0x39[1:0]	0	CH1_LNA_GAIN_CNTL	00: 18 dB 01: 24 dB 10: 12 dB 11: Reserved REG52[15] should be set as 1.
57[3:2]	0x39[3:2]	0	CH2_LNA_GAIN_CNTL	
57[5:4]	0x39[5:4]	0	CH3_LNA_GAIN_CNTL	00: 18 dB 01: 24 dB 10: 12 dB 11: Reserved REG52[15] should be set as 1.
57[7:6]	0x39[7:6]	0	CH4_LNA_GAIN_CNTL	
57[9:8]	0x39[9:8]	0	CH5_LNA_GAIN_CNTL	
57[11:10]	0x39[11:10]	0	CH6_LNA_GAIN_CNTL	
57[13:12]	0x39[13:12]	0	CH7_LNA_GAIN_CNTL	
57[15:14]	0x39[15:14]	0	CH8_LNA_GAIN_CNTL	
59[3:2]	0x3B[3:2]	0	HPF_LNA	00: 100 kHz 01: 50 kHz 10: 200 kHz 11: 150 kHz with 0.015 μF on INMx
59[6:4]	0x3B[6:4]	0	DIG_TGC_ATT_GAIN	000: 0-dB attenuation 001: 6-dB attenuation N: About N × 6 dB attenuation when 59[7] = 1
59[7]	0x3B[7]	0	DIG_TGC_ATT	0: Disable digital TGC attenuator 1: Enable digital TGC attenuator
59[8]	0x3B[8]	0	CW_SUM_AMP_PDN	0: Power down 1: Normal operation <b>Note:</b> 59[8] is only effective in TGC test mode.
59[9]	0x3B[9]	0	PGA_TEST_MODE	0: Normal CW operation 1: PGA outputs appear at CW outputs.
61[13]	0x3D[13]	0	V2I_CLAMP	0: Clamp disabled 1: Clamp enabled at the V2I input. An additional voltage clamp at the V2I input. This limits the amount of overload signal the PGA sees. <b>Note:</b> This bit is supported by AFE5809 with date code later than 2014, that is, date code >41XXXX.
61[14]	0x3D[14]	0	5MHz_LPF	0: 5-MHz LPF disabled 1: 5-MHz LPF enabled. Suppress signals >5 MHz or high-order harmonics. <b>The LPF Register 51[3:1] needs to be set as 100, that is, 10 MHz.</b> <b>Note:</b> This bit is supported by AFE5809 with date code later than 2014, that is date code >41XXXX.

Address (DEC)	Address (HEX)	Default Value	Function	Description
61[15]	0x3D[15]	0	PGA_CLAMP_-6dBFS	<p>0: Disable the –6-dBFS clamp. PGA_CLAMP is set by Reg51[7:5].</p> <p>1: Enable the –6-dBFS clamp. <b>PGA_CLAMP Reg51[7:5] should be set as 000 in the low-noise mode or 100 in the low-power/medium-power mode.</b> In this setting, PGA output HD3 will be worsen by 3 dB at –6-dBFS ADC input. The actual PGA output is reduced to approximately 1.5 Vpp, about 2.5 dB below the ADC full-scale input 2 Vpp. As a result, AFE5809's LPF is not saturated, and it can suppress harmonic signals better at PGA output. Due to PGA output reduction, the ADC output dynamic range is impacted.</p> <p><b>Note: This bit is supported by AFE5809 with date code later than 2014, that is date code &gt;41XXXX.</b></p> <p><b>Note: This bit is ONLY valid when PGA=24dB.</b></p>

### 8.6.1.4 VCA Register Description

#### 8.6.1.4.1 LNA Input Impedances Configuration (Active Termination Programmability)

Different LNA input impedances can be configured through the register 52[4:0]. By enabling and disabling the feedback resistors between LNA outputs and ACTx pins, LNA input impedance is adjustable accordingly. [Table 5](#) describes the relationship between LNA gain and 52[4:0] settings. The input impedance settings are the same for both TGC and CW paths.

The AFE5809 device also has four preset active termination impedances as described in 52[7:6]. An internal decoder is used to select appropriate resistors corresponding to different LNA gain.

**Table 5. Register 52[4:0] Description**

52[4:0]/0x34[4:0]	FUNCTION
00000	No feedback resistor enabled
00001	Enables 450-Ω feedback resistor
00010	Enables 900-Ω feedback resistor
00100	Enables 1800-Ω feedback resistor
01000	Enables 3600-Ω feedback resistor
10000	Enables 4500-Ω feedback resistor

The input impedance of AFE can be programmed through Register 52[8:0]. Each bit of Register 52[4:0] controls one active termination resistor. The following tables indicate the nominal impedance values when individual active termination resistors are selected. See [Active Termination](#) for more details. [Table 6](#) shows the corresponding impedances under different Register 52[4:0] values, while [Table 7](#) shows the Register 52[4:0] settings under different impedances.

**NOTE**

[Table 6](#) and [Table 7](#) show nominal input impedance values. Due to silicon process variation, the actual values can vary.

**Table 6. Register 52[4:0] versus LNA Input Impedances**

52[4:0]/0x34[4:0]	00000	00001	00010	00011	00100	00101	00110	00111
LNA:12dB	High Z	150 Ω	300 Ω	100 Ω	600 Ω	120 Ω	200 Ω	86 Ω
LNA:18dB	High Z	90 Ω	180 Ω	60 Ω	360 Ω	72 Ω	120 Ω	51 Ω
LNA:24dB	High Z	50 Ω	100 Ω	33 Ω	200 Ω	40 Ω	66.67 Ω	29 Ω
52[4:0]/0x34[4:0]	01000	01001	01010	01011	01100	01101	01110	01111
LNA:12dB	1200 Ω	133 Ω	240 Ω	92 Ω	400 Ω	109 Ω	171 Ω	80 Ω

**Table 6. Register 52[4:0] versus LNA Input Impedances (continued)**

52[4:0]/0x34[4:0]	00000	00001	00010	00011	00100	00101	00110	00111
LNA:18dB	720 Ω	80 Ω	144 Ω	55 Ω	240 Ω	65 Ω	103 Ω	48 Ω
LNA:24dB	400 Ω	44 Ω	80 Ω	31 Ω	133 Ω	36 Ω	57 Ω	27 Ω
52[4:0]/0x34[4:0]	10000	10001	10010	10011	10100	10101	10110	10111
LNA:12dB	1500 Ω	136 Ω	250 Ω	94 Ω	429 Ω	111 Ω	176 Ω	81 Ω
LNA:18dB	900 Ω	82 Ω	150 Ω	56 Ω	257 Ω	67 Ω	106 Ω	49 Ω
LNA:24dB	500 Ω	45 Ω	83 Ω	31 Ω	143 Ω	37 Ω	59 Ω	27 Ω
52[4:0]/0x34[4:0]	11000	11001	11010	11011	11100	11101	11110	11111
LNA:12dB	667 Ω	122 Ω	207 Ω	87 Ω	316 Ω	102 Ω	154 Ω	76 Ω
LNA:18dB	400 Ω	73 Ω	124 Ω	52 Ω	189 Ω	61 Ω	92 Ω	46 Ω
LNA:24dB	222 Ω	41 Ω	69 Ω	29 Ω	105 Ω	34 Ω	51 Ω	25 Ω

**Table 7. LNA Input Impedances versus Register 52[4:0]**

Z (Ω)	LNA:12dB	LNA:18dB	LNA:24dB	Z (Ω)	LNA:12dB	LNA:18dB	LNA:24dB	Z (Ω)	LNA:12dB	LNA:18dB	LNA:24dB
25			11111	67		10101		143			10100
27			10111/01111	69			11010	144		01010	
29			00111/11011	72		00101		150	00001	10010	
31			01011/10011	73		11001		154	11110		
33			00011	76	11111			171	01110		
34			11101	80	01111	01001	01010	176	10110		
36			01101	81	10111			180		00010	
37			10101	82		10001		189		11100	
40			00101	83			10010	200	00110		00100
41			11001	86	00111			207	11010		
44			01001	87	11011			222			11000
45			10001	90		00001		240	01010	01100	
46		11111		92	01011	11110		250	10010		
48		01111		94	10011			257		10100	
49		10111		100	00011		00010	300	00010		
50			00001	102	11101			316	11100		
51			00111/11110	103		01110		360		00100	
52		11011		105			11100	400	01100	11000	01000
55		01011		106		10110		429	10100		
56		10011		109	01101			500			10000
57			01110	111	10101			600	00100		
59			10110	120	00101	00110		667	11000		
60		00011		122	11001			720		01000	
61		11101		124		11010		900		10000	
65		01101		133	01001		01100	1200	01000		
66.7			00110	136	10001			1500	10000		

### 8.6.1.4.2 Programmable Gain for CW Summing Amplifier

Different gain can be configured for the CW summing amplifier through the register 54[4:0]. By enabling and disabling the feedback resistors between the summing amplifier inputs and outputs, the gain is adjustable accordingly to maximize the dynamic range of CW path. [Table 8](#) describes the relationship between the summing amplifier gain and 54[4:0] settings.

**Table 8. Register 54[4:0] Description**

54[4:0]/0x36[4:0]	FUNCTION
00000	No feedback resistor
00001	Enables 250-Ω feedback resistor
00010	Enables 250-Ω feedback resistor
00100	Enables 500-Ω feedback resistor
01000	Enables 1000-Ω feedback resistor
10000	Enables 2000-Ω feedback resistor

**Table 9. Register 54[4:0] vs Summing Amplifier Gain**

54[4:0]/0x36[4:0]	00000	00001	00010	00011	00100	00101	00110	00111
CW I/V Gain	N/A	0.5	0.5	0.25	1	0.33	0.33	0.20
54[4:0]/0x36[4:0]	01000	01001	01010	01011	01100	01101	01110	01111
CW I/V Gain	2	0.4	0.4	0.22	0.67	0.29	0.29	0.18
54[4:0]/0x36[4:0]	10000	10001	10010	10011	10100	10101	10110	10111
CW I/V Gain	4	0.44	0.44	0.24	0.80	0.31	0.31	0.19
54[4:0]/0x36[4:0]	11000	11001	11010	11011	11100	11101	11110	11111
CW I/V Gain	1.33	0.36	0.36	0.21	0.57	0.27	0.27	0.17

### 8.6.1.4.3 Programmable Phase Delay for CW Mixer

Accurate CW beamforming is achieved through adjusting the phase delay of each channel. In the AFE5809 device, 16 different phase delays can be applied to each LNA output. It meets the standard requirement of

typical ultrasound beamformer, that is,  $\frac{1}{16}\lambda$  beamformer resolution. [Table 8](#) describes the relationship between the phase delays and the register 55 and 56 settings.

**Table 10. CW Mixer Phase Delay vs Register Settings**  
 CH1: 55[3:0], CH2: 55[7:4], CH3: 55[11:8], CH4: 55[15:12],  
 CH5: 56[3:0], CH6: 56[7:4], CH7: 56[11:8], CH8: 56[15:12]

Phase Delay	Register Settings							
CHX_CW_MIXER_PHASE	0000	0001	0010	0011	0100	0101	0110	0111
PHASE SHIFT	0	22.5°	45°	67.5°	90°	112.5°	135°	157.5°
CHX_CW_MIXER_PHASE	1000	1001	1010	1011	1100	1101	1110	1111
PHASE SHIFT	180°	202.5°	225°	247.5°	270°	292.5°	315°	337.5°

## 8.6.2 Digital Demodulator Register Description

**Table 11. Digital Demodulator Register Map<sup>(1)(2)(3)</sup>**

Register Name	Address (HEX) BIT [5:0]	Address (DEC) BIT [5:0]	Default	Description
MANUAL_TX_TRIG	00[2]	00[2]	0	1: Generate internal TX_TRIG (self clear, write only). This is an alternative for TX_SYNC hardware pulse.
REGISTER_READOUT_ENABLE	00[1]	00[1]	0	1: Enables readout of register at SDOUT pin (write only)
CHIP_ID	01[4:0]	01[4:0]	0	Unique chip ID
OUTPUT_MODE	02[15:13]	02[15:13]	0	000 = Normal operation 011 = Custom pattern (set by register 05) <b>Note:</b> LSB always comes out first regardless of whether 0x04[4] = 0 or 1. 111 = chipID + ramp test pattern. ChipID (5 bit) and subchip information (3 bit) are the 8 LSBs and the ramp pattern is in the rest MSBs. (0x0A[9] = 1)
SERZ_FACTOR	03[14:13]	03[14:13]	11	Serialization factor (output rate) 00 = 10x 01 = 12x 10 = 14x 11 = 16x <b>Note:</b> This register is different from the ADC SERIALIZED_DATA_RATE. The demod and ADC serialization factors must be matched. See .
OUTPUT_RESOLUTION	03[11:9]	03[11:9]	0	Output resolution of the demodulator. It refers to the ADC resolution when the demodulator is bypassed. 100 = 16 bit (demod only) 000 = 14 bit 001 = 13 bit 010 = 12 bit
MSB_FIRST	04[4]	04[4]	0	0 = LSB first 1 = MSB first This bit does not affect the test mode: customer pattern, that is, 02[15:13] = 011B. <b>Note:</b> in the CUSTOM_PATTERN mode, the output is always set as LSB first regardless of this bit setting.
CUSTOM_PATTERN	05[15:0]	05[15:0]	0000	Custom data pattern for LVDS (0x02[15:13] = 011)
COEFF_MEM_ADDR_WR	06[7:0]	06[7:0]	0	Write address offset to coefficient memory (auto increment)
COEFF_BANK	07[111:0]	07[111:0]	—	Writes chunks of 112 bits to the coefficient memory. This RAM does not have default values, so it is necessary to write required values to the RAM. TI recommends to configure the RAM before other registers.
PROFILE_MEM_ADDR_W R	08[4:0]	08[4:0]	0	Write address offset to profile memory (auto increment)
PROFILE_BANK	09 [63:0]	09 [63:0]	—	Writes chunks of 64 bits to the profile memory (effective 62 bits because two LSBs are ignored). This RAM does not have default values, so it is necessary to write required values to the RAM. TI recommends to configure the RAM before other registers.
<b>RESERVED</b>	0A[15]	10[15]	0	<b>Must set to 0</b>
MODULATE_BYPASS	0A[14]	10[14]	0	Arrange the demodulator output format for I/Q data. See <a href="#">Table 10</a> .
DEC_SHIFT_SCALE	0A[13]	10[13]	0	0 = No additional shift applied to the decimation filter output. 1 = Shift the decimation filter output by 2 bits additionally, that is apply 12-dB additional digital gain.
DHPF	0A[12]	10[12]	1	0 = Enable first-order digital HPF. –3 dB cut off frequency is at $0.0225 \times F_s / 2$ . Its transfer function equation is $h(n) = a / b$ , where $a = [1 - 7569 / 2^{13}]$ and $b = [1 - 1]$ ; 1 = Disable first-order digital HPF.

(1) When programming the SPI, 8-bit address is required. This table and the following sections only list the Add\_Bit5 to Add\_Bit0. The Add\_Bit7 = SCID1\_SEL and Add\_Bit6 = SCID0\_SEL must be appended as 11, 10, or 01, which determines if SubChip1 or SubChip0 is being programmed. If SCID1\_SEL, SCID0\_SEL = 11, then both subchips get written with the same register value. See [Table 2](#).

(2) Reserved register bits must be programmed based on their descriptions.

(3) Unlisted register bits must be programmed as zeros.

**Table 11. Digital Demodulator Register Map<sup>(1)(2)(3)</sup> (continued)**

Register Name	Address (HEX) BIT [5:0]	Address (DEC) BIT [5:0]	Default	Description
OUTPUT_CHANNEL_SEL	0A[11]	10[11]	0	Swap channel pairs. It is used in 4 LVDS bypass configuration to select which of the two possible data streams to pass on. See <a href="#">Table 10</a> .
SIN_COS_RESET_ON_TX_TRIG	0A[10]	10[10]	1	0 = Continuous phase 1 = Reset down conversion phase on TX_TRIG
FULL_LVDS_MODE	0A[9]	10[9]	0	0 = Use 4 LVDS lines (1, 3, 5, 7) 1 = Use 8 LVDS lines (1 through 8) <b>Note:</b> 4 LVDS mode valid only for decimation factors $\geq 4$ . See <a href="#">Table 13</a> .
<b>RESERVED</b>	0A[8:5]	10[8:5]	0	<b>Must set to 0</b>
<b>RESERVED</b>	0A[4]	10[4]	0	<b>Must set to 1</b>
DEC_BYPASS	0A[3]	10[3]	0	0 = Enable decimation filter 1 = Bypass decimation filter
DWN_CNV_BYPASS	0A[2]	10[2]	0	0 = Enable down conversion block 1 = Bypass down conversion block. <b>Note:</b> the decimation filter can still be used when the down conversion block is bypassed.
<b>RESERVED</b>	0A[1]	10[1]	1	<b>Must be set as 1</b>
DC_REMOVAL_BYPASS	0A[0]	10[0]	0	0 = Enable DC removal block 1 = Bypass DC removal block
SYNC_WORD	0B[15:0]	11[15:0]	0x2772	LVDS sync word. When MODULATE_BYPASS = 1, there is no sync word output.
PROFILE_INDX	0E[15:11]	14[15:11]	0	Profile word selector. The Profile Index register is a special 5-bit data register. Read value still uses 16-bit convention, which means data will be available on LSB 0e[4:0])
DC_REMOVAL_1_5	14[13:0]	20[13:0]	0	54[13:0] → DC offset for channel 1, SCID1_SEL, SCID0_SEL = 01 94[13:0] → DC offset for channel 5, SCID1_SEL, SCID0_SEL = 10 <b>Note:</b> Considering the CH-to-CH DC offset variation, the offset value must be set individually. Therefore, SCID1_SEL, SCID0_SEL should not be set as 11. <b>Note:</b> DC_REMOVAL_X_X registers are write-only.
DC_REMOVAL_2_6	15[13:0]	21[13:0]	0	55[13:0] → DC offset for channel 2, SCID1_SEL, SCID0_SEL = 01 95[13:0] → DC offset for channel 6, SCID1_SEL, SCID0_SEL = 10 <b>Note:</b> Considering the CH-to-CH DC offset variation, the offset value must be set individually. Therefore, SCID1_SEL, SCID0_SEL should not be set as 11. <b>Note:</b> DC_REMOVAL_X_X registers are write-only.
DC_REMOVAL_3_7	16[13:0]	22[13:0]	0	56[13:0] → DC offset for channel 3, SCID1_SEL, SCID0_SEL = 01 96[13:0] → DC offset for channel 7, SCID1_SEL, SCID0_SEL = 10 <b>Note:</b> Considering the CH-to-CH DC offset variation, the offset value must be set individually. Therefore, SCID1_SEL, SCID0_SEL should not be set as 11. <b>Note:</b> DC_REMOVAL_X_X registers are write-only.
DC_REMOVAL_4_8	17[13:0]	23[13:0]	0	57[13:0] → DC offset for channel 4, SCID1_SEL, SCID0_SEL = 01 97[13:0] → DC offset for channel 8, SCID1_SEL, SCID0_SEL = 10 <b>Note:</b> Considering the CH-to-CH DC offset variation, the offset value must be set individually. Therefore, SCID1_SEL, SCID0_SEL should not be set as 11. <b>Note:</b> DC_REMOVAL_X_X registers are write-only.
DEC_SHIFT_FORCE_EN	1D[7]	29[7]	0	0 = Profile vector specifies the number of bit to shift for the decimation filter output. 1 = Register 1D[6:4] specifies the number of bit to shift for the decimation filter output.
DEC_SHIFT_FORCE	1D[6:4]	29[6:4]	0	Specify that the decimation filter output is right-shifted by (20 – N) bit, N = 0x1D[6:4]. N = 0, minimal digital gain; N = 7 maximal digital gain; additional 12-dB digital gain can be applied by setting DEC_SHIFT_SCALE = 1, that is, 0x0A[13] = 1
TM_COEFF_EN	1D[3]	29[3]	0	1 = Set coefficient output test mode

**Table 11. Digital Demodulator Register Map<sup>(1)(2)(3)</sup> (continued)**

Register Name	Address (HEX) BIT [5:0]	Address (DEC) BIT [5:0]	Default	Description
TM_SINE_EN	1D[2]	29[2]	0	1 = Set sine output mode; the sine waveform specifications can be configured through register 0x1E.
<b>RESERVED</b>	1D[1]	29[1]	0	<b>Must set to 0</b>
<b>RESERVED</b>	1D[0]	29[0]	0	<b>Must set to 0</b>
TM_SINE_DC	1E[15:9]	30[15:9]	0	7-bit signed value for sine wave DC offset control.
TM_SINE_AMP	1E[8:5]	30[8:5]	0	4-bit unsigned value, controlling the sine wave amplitude (powers of two), from unity to the full scale of 14 bit, including saturation. 0 = No sine (only DC)
TM_SINE_STEP	1E[4:0]	30[4:0]	0	5-bit unsigned value, controlling the sine wave frequency with resolution of $F_s / 2^6$ , which is 0.625 MHz for 40-MHz ADC clock.
MANUAL_COEFF_START_EN	1F[15]	31[15]	0	0 = The starting address of the coefficient RAM is set by the profile vector, that is, the starting address is set manually. 1 = The starting address of the coefficient RAM is set by the register 0x1F[14:7].
MANUAL_COEFF_START_ADDR	1F[14:7]	31[14:7]	0	When 0x1F[15] is set, the starting address of coefficient RAM is set by these 8 bits.
MANUAL_DEC_FACTOR_EN	1F[6]	31[6]	0	0 = The decimation factor is set by profile vector. 1 = The decimation factor is set by the register 0x1F[5:0].
MANUAL_DEC_FACTOR	1F[5:0]	31[5:0]	0	When 0x1F[6] is set, the decimation factor is set by these 6 bits. <b>Note:</b> It is from 1 to 32.
MANUAL_FREQ_EN	20[0]	32[0]	0	0 = The down convert frequency is set by profile vector. 1 = The down convert frequency is set by the register 0x21[15:0].
MANUAL_FREQ	21[15:0]	33[15:0]	0	When 0x20[0] is set, the value of manual down convert frequency is calculated as $N \times F_s / 2^{16}$

**NOTE**

RF mode allows for the streaming of ADC data through the demodulator to the LVDS serializer. RF mode without sync word can be set by the following:

- Write 0x0041 to register 0xDF; that is MANUAL\_DEC\_FACTOR\_EN = 1 and MANUAL\_DEC\_FACTOR = 1.
- Write 0x121F to register 0xCA, that is, MODULATE\_BYPASS = 0, FULL\_LVDS\_MODE = 1, DC\_REMOVAL\_BYPASS = 1, DWN\_CNV\_BYPASS = 1. DEC\_BYPASS = 1, SYN\_COS\_RESET\_ON\_TX\_TRIG = 0.
- Write 0x6800 to register 0xC3, that is, SERZ\_FACTOR = 16x, OUTPUT\_RESOLUTION = 16x,
- Write 0x0010 to register 0xC4, that is, MSB\_FIRST = 1
- Provide TX\_TRIG pulse or set Register 0xC0[2] MANUAL\_TX\_TRIG

**Table 12. Configuring Data Output**

Register Name	SPI Address
SERZ_FACTOR	0x03[14:13]
OUTPUT_RESOLUTION	0x03[11:9]
MSB_FIRST	0x04[4]
OUT_MODE	0x02[15:13]
CUSTOM_PATTERN	0x05[15:0]
OUTPUT_CHANNEL_SEL	0x0A[11]
MODULATE_BYPASS	0x0A[14]
FULL_LVDS_MODE	0x0A[9]

**1. LVDS Serializer configuration:**

- Serialization Factor 0x03[14:13]: It can be set using demodulator register SERZ\_FACTOR. Default serialization factor for the demodulator is 16x. However, the actual LVDS clock speed can be set by the serialization factor in the ADC SPI interface as well; the ADC serialization factor is adjusted to 14x by default. Therefore, it is necessary to sync these two settings when the demodulator is enabled, that is, set the ADC register 0x03[14:13] = 01. For RF mode (passing 14 bits only), demodulator serialization factor can be changed to 14x by setting demodulator register 0xC3[14:13] to 10.
- Output Resolution 0x03[11:9]: In the default setting, it is 14 bits. The demodulator output resolution depends on the decimation factor. 16-bit resolution can be used when higher decimation factor is selected.

**2. Channel selection:**

- Using register MODULATE\_BYPASS 0x0A[14], channel output mode can be selected as IQ modulated or single-channel I or Q output.
- Channel output is also selected using registers OUTPUT\_CHANNEL\_SEL 0x0A[11] and FULL\_LVDS\_MODE 0x0A[9] and decimation factor.
- Each of the two demodulator subchips in a device has four channels named A, B, C, and D.

---

**NOTE**

After decimation, the LVDS FCLK rate keeps the same as the ADC sampling rate. Considering the reduced data amount, zeros are appended after I and Q data and ensure the LVDS data rate matches the LVDS clock rate. For detailed information about channel multiplexing, see [Table 13](#). In the table, A.I refers to CHA in-phase output, and A.Q refers to CHA quadrature output. For example,  $M = 3$ , the valid data output rate is  $F_s / 3$  for both I and Q channels, that is  $2 \times F_s / 3$  bandwidth is occupied. The left  $F_s / 3$  bandwidth is then filled by  $M-2$  zeros. As a result, the demod LVDS output data are A.I, A.Q, 0, A.I A.Q 0 after SYNC\_WORD,  $FCLK = F_s$  and  $DCLK = F_s \times 8$ . When two ADC CHs' data are transferred by one LVDS lane,  $M-4$  zeros are filled after A.I, A.Q, B.I, and B.Q. See more details in [Table 13](#) and [Figure 87](#).

---

**Table 13. Channel Selection<sup>(1)</sup>**

Decimation Factor (M)	Modulate Bypass	Output Channel Select	Full LVDS Mode	Decimation Factor M	LVDS Output Description	
$M \geq 2$	0	0	0	$M < 4$	LVDS1: A.I, A.Q, (zeros)	
					LVDS2: B.I, B.Q, (zeros)	
					LVDS3: C.I, C.Q, (zeros)	
					LVDS4: D.I, D.Q, (zeros)	
			$M \geq 4$	LVDS1: A.I, A.Q, B.I, B.Q, (zeros) LVDS2: idle		
				LVDS3: C.I, C.Q, D.I, D.Q, (zeros) LVDS4: idle		
	1	X	1	X	LVDS1: A.I, A.Q, (zeros)	
					LVDS2: B.I, B.Q, (zeros)	
					LVDS3: C.I, C.Q, (zeros)	
					LVDS4: D.I, D.Q, (zeros)	
	$M \geq 2$	0	1	0	$M < 4$	LVDS1: B.I, B.Q, (zeros)
						LVDS2: A.I, A.Q, (zeros)
LVDS3: D.I, D.Q, (zeros)						
LVDS4: C.I, C.Q, (zeros)						
$M \geq 4$				LVDS1: B.I, B.Q, A.I, A.Q, (zeros)		
				LVDS2: idle		
1		X	1	X	LVDS3: D.I, D.Q, C.I, C.Q, (zeros)	
					LVDS4: idle	
					LVDS1: B.I, B.Q, (zeros)	
					LVDS2: A.I, A.Q, (zeros)	
$M \geq 2$		1	0	X	X	LVDS3: D.I, D.Q, (zeros)
						LVDS4: C.I, C.Q, (zeros)
	LVDS1: A.I; Note: the same A.I is repeated by M times.					
	LVDS2: A.Q; Note: the same A.Q is repeated by M times.					
	1	1	X	X	LVDS3: C.I; Note: the same C.I is repeated by M times.	
					LVDS4: C.Q; Note: the same C.Q is repeated by M times.	
					LVDS1: B.I; Note: the same B.I is repeated by M times.	
					LVDS2: B.Q; Note: the same B.Q is repeated by M times.	
M = 1	0	0	X	1	LVDS1: A.I; LVDS2: B.I; LVDS3: C.I; LVDS4: D.I	
M = 1	0	1	X	1	LVDS1: B.I; LVDS2: A.I; LVDS3: D.I; LVDS4: C.I	
M = 1	1	0	X	1	LVDS1: A.I; LVDS2: A.Q; LVDS3: C.I; LVDS4: C.Q	
M = 1	1	1	X	1	LVDS1: B.I; LVDS2: B.Q; LVDS3: D.I; LVDS4: D.Q	

(1) This table refers to individual demodulator subchip, which has four LVDS outputs, that is LVDS1 through LVDS4; and four input CHs, that is CH.A to CH.D. See [Figure 85](#).

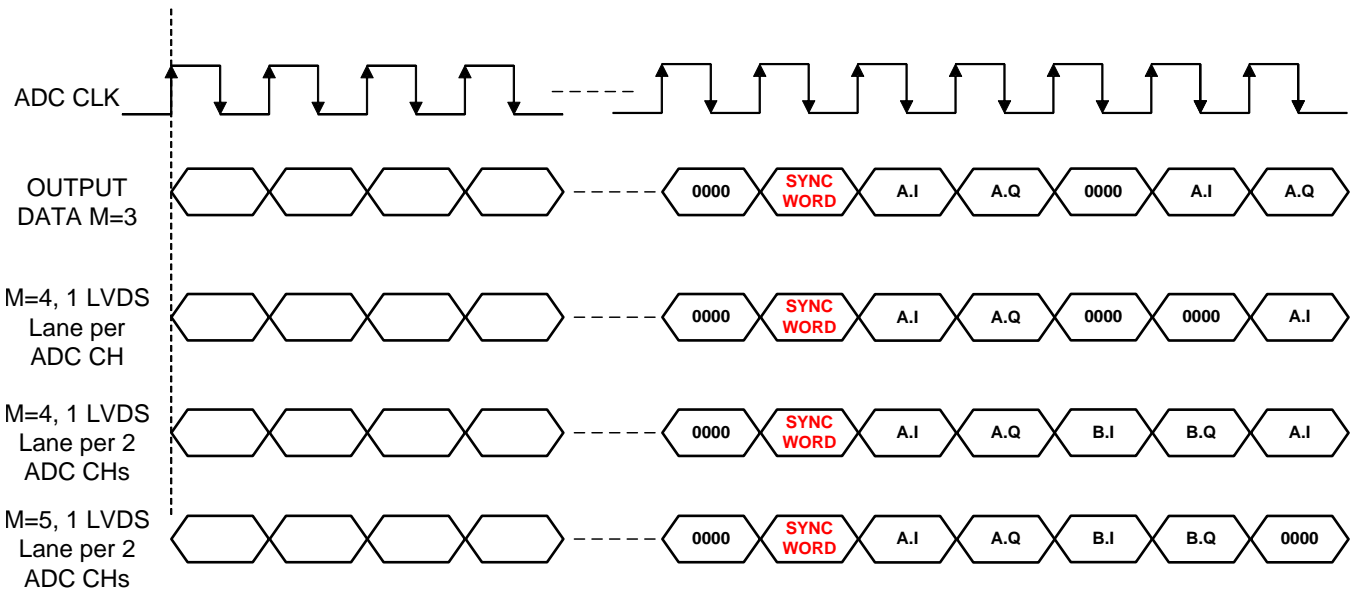

Figure 87. Output Data Format at M = 3~5

3. Output mode:

- Using register OUT\_MODE, ramp pattern and custom pattern can be enabled.
- Custom pattern: In the case of a custom pattern, custom pattern value can be set using register CUSTOM\_PATTERN. Note: LSB always comes out first regardless of whether 0x04[4] = 0 or 1, that is, MSB\_FIRST = 0 or 1.
- Ramp pattern: Demodulator generated ramp pattern includes information of chip\_id as well. 8 MSB (that is, Data[15..8]) bits are ramp pattern. Next 5 bits (that is, Data[3..7]) gives value of chip ID. Data[2] corresponds to subchip ID, 0 or 1; Data[1:0] are filled with zeros.

**NOTE**

Test pattern from the ADC output stage can NOT be sent to the demodulator; it can only be sent to the LVDS serializer when the demodulator is off.

**Table 14. DC Removal Block**

Register Name	SPI Address
DC_REMOVAL_BYPASS	0x0A[0]
DC_REMOVAL_1_5	0x14[13:0]
DC_REMOVAL_2_6	0x15[13:0]
DC_REMOVAL_3_7	0x16[13:0]
DC_REMOVAL_4_8	0x17[13:0]

- DC removal block can be bypassed using the register bit DC\_REMOVAL\_BYPASS.
- DC removal is designed to be done manually.
- Manual DC offset removal: Registers DC\_REMOVAL\_1\_5, DC\_REMOVAL\_2\_6, DC\_REMOVAL\_3\_7, and DC\_REMOVAL\_4\_8 can be used to give manual offset. Value should be given in 2's complement format. In the case of these registers, SCID values should be given accordingly (see [Digital Demodulator SPI Description](#) for more information). Example: For DC offset of channel 5, the address of the register would be 0x91 (in hex). Here SCID0 is 0 and SCID1 is 1.

**Table 15. Down Conversion Block**

Register Name	SPI Address
DWN_CNV_BYPASS	0x0A[2]
SIN_COS_RESET_ON_TX_TRIG	0x0A[10]
MANUAL_FREQ_EN	0x20 [0]
MANUAL_FREQ	0x21[15:0]

- Down conversion block can be bypassed using register DWN\_CNV\_BYPASS.
- Down conversion frequency can be given using the down conversion frequency ( $f$ ) parameter of the profile vector. Alternatively, manual registers MANUAL\_FREQ\_EN and MANUAL\_FREQ can be used to provide down conversion frequency.
- Down conversion frequency ( $f$ ): ' $f$ ' can be set with resolution  $F_s / 2^{16}$  (where  $F_s$  is the sampling frequency). An integer value of ' $2^{16}f / F_s$ ' is given to the profile vector or respective register.
- Down conversion signal can be configured to be reset at each TX\_TRIG pulse. This facility can be enabled using SIN\_COS\_RESET\_ON\_TX\_TRIG.

**Table 16. Decimation Block**

Register Name	SPI Address
DEC_BYPASS	0x0A[3]
MANUAL_DEC_FACTOR_EN	0x1F [6]
MANUAL_DEC_FACTOR	0x1F[5:0]
MANUAL_COEFF_START_EN	0x1F[15]
MANUAL_COEFF_START_ADDR	0x1F[14:7]
DEC_SHIFT_FORCE_EN	0x1D[7]
DEC_SHIFT_FORCE	0x1D[6:4]
DEC_SHIFT_SCALE	0x0A[13]

- Decimation block can be bypassed using register DEC\_BYPASS.
- Decimation factor: This can be set using the decimation factor (M) parameter of the profile vector. Alternatively, it can be set using registers MANUAL\_DEC\_FACTOR\_EN and MANUAL\_DEC\_FACTOR.
- Filter coefficients: Filter coefficients should be written to coefficient RAM (see [Profile RAM and Coefficient RAM](#)). The format of the filter coefficient is 2's complement. Its address pointer should be given in profile vector, or alternatively, registers MANUAL\_COEFF\_START\_EN and MANUAL\_COEFF\_START\_ADDR can be used.
- Filter digital gain: Decimation block takes 14-bit input data and 14-bit input coefficients and gives 36-bit output internally. While implementing this FIR filter, after multiplication and addition, the 36-bit internal filter output should be scaled approximately to make the final demod output as 16 bit, that is, applying digital gain or attenuation. Filter gain or attenuation depends on two parameters: decimation shift scale and gain compensation factor.
- Decimation shift scale can be chosen using register DEC\_SHIFT\_SCALE. The gain compensation factor can be given to the gain compensation factor (G) parameter of the profile vector, or can be given using registers DEC\_SHIFT\_FORCE\_EN and DEC\_SHIFT\_FORCE.
- The internal 36-bit filter output is right-shifted by N bits, where N equals:
  - 20-G when Dec\_Shift\_Scale = 0
  - 20-G-2 when Dec\_Shift\_Scale = 1

The minimal gain occurs when  $G = 0$  and DEC\_SHIFT\_SCALE = 0. The total scaling range can be a factor of  $2^9$ , that is, approximately 54 dB.

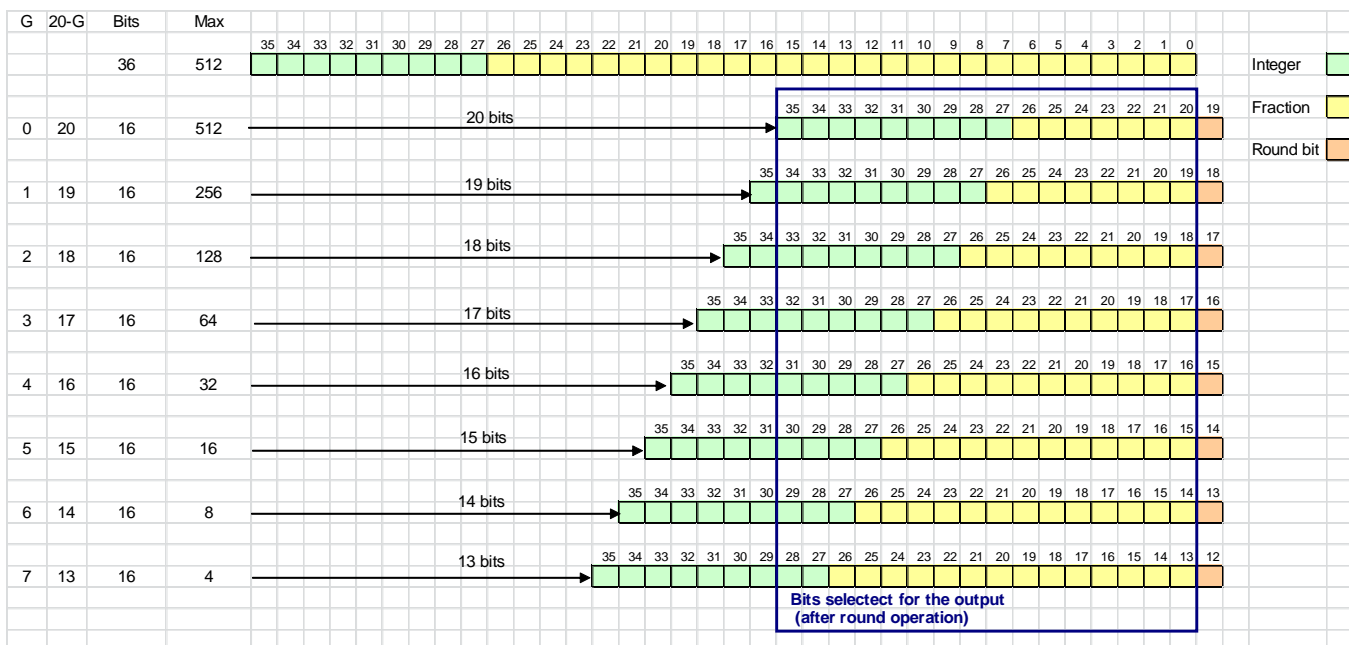

**Figure 88. Shifted Output When DEC\_SHIFT\_SCALE=0**

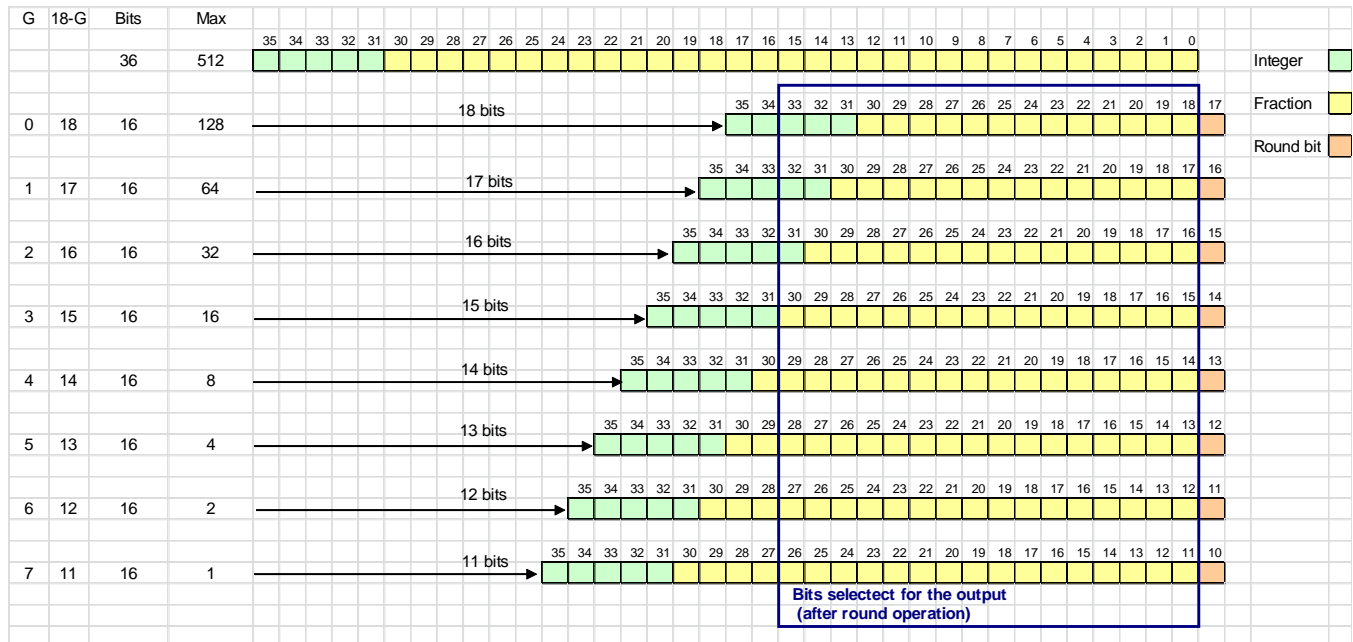

Figure 89. Shifted Output when DEC\_SHIFT\_SCALE=1

Table 17. Test Modes

Register Name	SPI Address
TM_SINE_DC	0x1E[15:9]
TM_SINE_AMP	0x1E[8:5]
TM_SINE_STEP	0x1E[4:0]
TM_SINE_EN	0x1D[2]
TM_COEFF_EN	0x1D[3]

1. Sine test mode:

The normal ADC output can be replaced by:

$$x_n = C + 2^k \sin\left(\frac{\pi Nn}{2^5}\right) \tag{5}$$

- N is a 5-bit unsigned value, controlling the sine wave frequency with resolution of  $F_S / 2^6$ , which is 0.625 MHz for 40-MHz ADC clock.
- k is 4-bit unsigned value, controlling the wave amplitude, from unity to the full scale of 14 bits, including saturation.
- C is 7-bit signed value for DC offset control.

The controlling values fit into one 16-bit register. This test pattern shall allow testing of demodulation, decimation filter, DC removal, gain control, and so on.

2. Coefficient output test mode:

- The input to the decimating filter can be replaced with a sequence of one impulse and zero samples, where one impulse (0x4000) is followed by (16 x M) zeros (that is, 0 x 0000).
- This mode is useful to check decimation filter coefficients.
- This mode can be enabled using register TM\_COEFF\_EN.

### 8.6.2.1 Profile RAM and Coefficient RAM

Writing data to profile RAM and coefficient RAM is similar to registers. Both RAMs do not get reset after resetting the device. RAM does not have default values, so it is necessary to write required values to RAM. RAM address values must be given to the pointer register that points to the location wherever data needs to be written. Because both RAMs are part of the demodulator, SPI\_DIG\_EN should be low /'0' while writing.

#### NOTE

TI recommends to program the profile and filter RAMs before configuring other registers.

A trigger is required to make new settings effective, such as profile RAM, coefficient RAM, and PROFILE\_INDX Reg.0x0E[15:11] —either an external trigger event through the TX\_SYNC\_IN pin or a manual trigger event through Register 0[2].

PROFILE\_INDX Reg.0x0E[15:11] must be reprogrammed to ensure new profile and filter RAMs loaded correctly.

ADC CLK is required during profile and coefficient RAM programming.

**Table 18. Profile Related Registers**

Register Name	SPI Address
PROFILE_MEM_ADDR_WR	0x08[4:0]
PROFILE_BANK	0x09[63:0]
PROFILE_INDEX	0x0E[15:11]

- Profile RAM can store up to 32 vectors/profiles. Each vector/profile has 64 bits.
- Pointer value should be given to the register PROFILE\_MEM\_ADDR\_WR before writing to RAM.
- The 64 bits of each vector/profile are arranged as follows:

**Table 19. Profile RAM<sup>(1)(2)</sup>**

NAME OF PARAMETER	ADDRESS	DESCRIPTION
Reserved	RAM[63:50]	Set to 0
Reserved	RAM[49:36]	Set to 0
Pointer to coeff memory (P) <sup>(3)</sup>	RAM[35:28]	A pointer to filter coefficient memory (8 bits), pointing to 8 coefficient blocks. The relevant coefficients start from address P × 8 in the coefficients memory and will continue for M blocks.
Decimation Factor (M) <sup>(3)</sup>	RAM[27:22]	Decimation factor for decimation block
Down conversion frequency (f) <sup>(3)</sup>	RAM[21:6]	Down conversion frequency for down conversion block
Reserved	RAM[5]	Set to 0
Gain compensation factor (G) <sup>(3)</sup>	RAM[4:2]	Gain compensation factor parameter for decimation block

(1) 2 LSB's (that is, RAM[1:0]) are ignored and can be set as zeros.

(2) A particular profile vector can be activated using register PROFILE\_INDEX. Address pointing to the location of particular vector is to be given in PROFILE\_INDEX.

(3) Alternative manual register is available

#### 8.6.2.1.1 Programming the Profile RAM

1. Set SEN and SPI\_DIG\_EN as 0.
2. Set SPI address 0xC8[4:0] with the base address, for example 0x0000. 0xC8 means both demodulator subchips are enabled.
3. The 64 profile vector bits are arranged as following:
  - RAM[63:50] = 0 (reserved)
  - RAM[49:36] = 0 (reserved)
  - RAM[35:28] = Pointer to coeff memory (8 bit)
  - RAM[27:22] = Decimation factor (6 bit)

- RAM[21:6] = Demodulation frequency (16 bit)
  - RAM[5] = 0
  - RAM[4:2] = Gain compensation factor (3 bit)
  - RAM[1:0] = 2 LSBs are ignored, can be set as zeros.
4. Write the above 64 bits to SPI address 0xC9 (MSB first).
  5. Repeat steps 3 and 4 for the following profile entries (the address in register 0xC8 auto increments).
  6. Set SEN and SPI\_DIG\_EN as 1.

#### 8.6.2.1.2 Procedure for Configuring Next Profile Vector

1. Write profile index (5 bits) to SPI address 0xCE[15:11]. 0xCE means both demodulator subchips are enabled.

**Table 20. Coefficient RAM**

Register Name	SPI Address
COEFF_MEM_ADDR_WR	0x06[7:0]
COEFF_BANK	0x07[111:0]
MANUAL_COEFF_START_ADDR	0x1F[14:7]
MANUAL_COEFF_START_EN	0x1F[15]

- Coefficient RAM can store up to 256 coefficient memory blocks. The size of each block is 112 bits.
- Pointer value should be given to the register COEFF\_MEM\_ADDR\_WR before writing to RAM.
- Write 112 bits to SPI address 0xC7 (MSB first). Each coefficient memory block consists of eight 14-bit coefficients which are aligned in the following manner: coefficient order from right to left and bit order from right to left).

**Table 21. Coefficient RAM Mapping**

Coeff 7[13:0]	Coeff 6[13:0]	Coeff 5[13:0]	Coeff 4[13:0]	Coeff 3[13:0]	Coeff 2[13:0]	Coeff 1[13:0]	Coeff 0[13:0]
111:98	97:84	83:70	69:56	55:42	41:28	27:14	13:0

**NOTE**

The coefficients are in 2's complement format. SPI serialization is done from left to right (0xCoeff 7[13] first and 0xCoeff 0[0] last)

- Because the decimation block uses  $16 \times M$  tap FIR filter and filter coefficients are symmetric, only half (that is  $8 \times M$ ) filter coefficients are necessary to be stored (M is the decimation factor). Each 8 coefficient block that is written to the memory represents a single phase of a polyphase filter. Therefore, the relation between the filter coefficients  $C_n$  and their index (i,j) in the coefficients memory is given by:

$$n = M \times (1 + l) - (1 + j)$$

where

- l is the index in the coefficients block, from 0 to 7.
- j is the block index, from 0 to (M – 1).

(6)

Example for M = 4

**Table 22. Coefficient RAM Mapping**

j\l	7	6	5	4	3	2	1	0
0	Coeff 31	Coeff 27	Coeff 23	Coeff 19	Coeff 15	Coeff 11	Coeff 7	Coeff 3
1	Coeff 30	Coeff 26	Coeff 22	Coeff 18	Coeff 14	Coeff 10	Coeff 6	Coeff 2
2	Coeff 29	Coeff 25	Coeff 21	Coeff 17	Coeff 13	Coeff 9	Coeff 5	Coeff 1
3	Coeff 28	Coeff 24	Coeff 20	Coeff 16	Coeff 12	Coeff 8	Coeff 4	Coeff 0

- Coefficient start address can be given using the Pointer to Coeff Memory (P) parameter of profile RAM. Alternatively, the start address can be given using register MANUAL\_COEFF\_START\_ADDR. (While using this register, register enable bit MANUAL\_COEFF\_START\_EN should be set to 1.)

#### 8.6.2.1.3 Programming the Coefficient RAM

1. Set SPI address 0xC6[7:0] with the base address, for example 0x0000. 0xC6 means both demodulator subchips are enabled.
2. Write 112 bits to SPI address 0xC7 (MSB first). Each coefficient memory word consists of eight 14-bit coefficients, which are aligned in the following manner: coefficient order from right to left and bit order from right to left.

---

#### NOTE

The coefficients are in 2s complement format.

---

**Figure 90.**

Coeff 7[13:0]	Coeff 6[13:0]	Coeff 5[13:0]	Coeff 4[13:0]	Coeff 3[13:0]	Coeff 2[13:0]	Coeff 1[13:0]	Coeff 0[13:0]
111:98	97:84	83:70	69:56	55:42	41:28	27:14	13:0

---

#### NOTE

SPI serialization is done from left to right (Coeff 7[13] first and Coeff 0[0] last).

---

3. Repeat the previous step for the following coefficient bulk entries (the address in register 0xC6 auto increments).

#### 8.6.2.1.4 Filter Coefficient Test Mode

Coefficient test mode allows for the streaming of coefficients through the demodulator to the LVDS. Filter coefficient test mode can be set by the following:

1. Enable TM\_COEFF\_EN.
2. Write OUTPUT\_RESOLUTION (0x03[11:9]) = 0b100, that is, 16-bit output. (output bit resolution of 14 bits will not give proper result.)
3. Write DC\_REMOVAL\_BYPASS (0x0A[0]) = 1, DWN\_CNV\_BYPASS (0x0A[2]) = 1.
4. Write DC\_DEC\_SHIFT\_FORCE\_EN (0x1D[7]) = 1, DEC\_SHIFT\_FORCE (0x1D[6:4]) = 0b110, and DEC\_SHIFT\_SCALE (0x0a[13]) = 1.
5. Write MODULATE\_BYPASS (0x0A[14]) = 1. After writing all of the above settings, coefficients come at the output in the sequence as follow.
6. M = 2
  - Address 0: C15 C13 C11 C09 C07 C05 C03 C01; Address 1: C14 C12 C10 C08 C06 C04 C02 C00
  - The order in which coefficients come at the output will be: 0 C01 C03 C05 C07 C09 C11 C13 C15 C14 C12 C10 C08 C06 C04 C02 C00 C00 C02 C04 C06 C08 C10 C12 C14 C15 C13 C11 C09 C07 C05 C03 C01 0
7. M = 8
  - The coefficients come to the output as shown in [Figure 91](#).

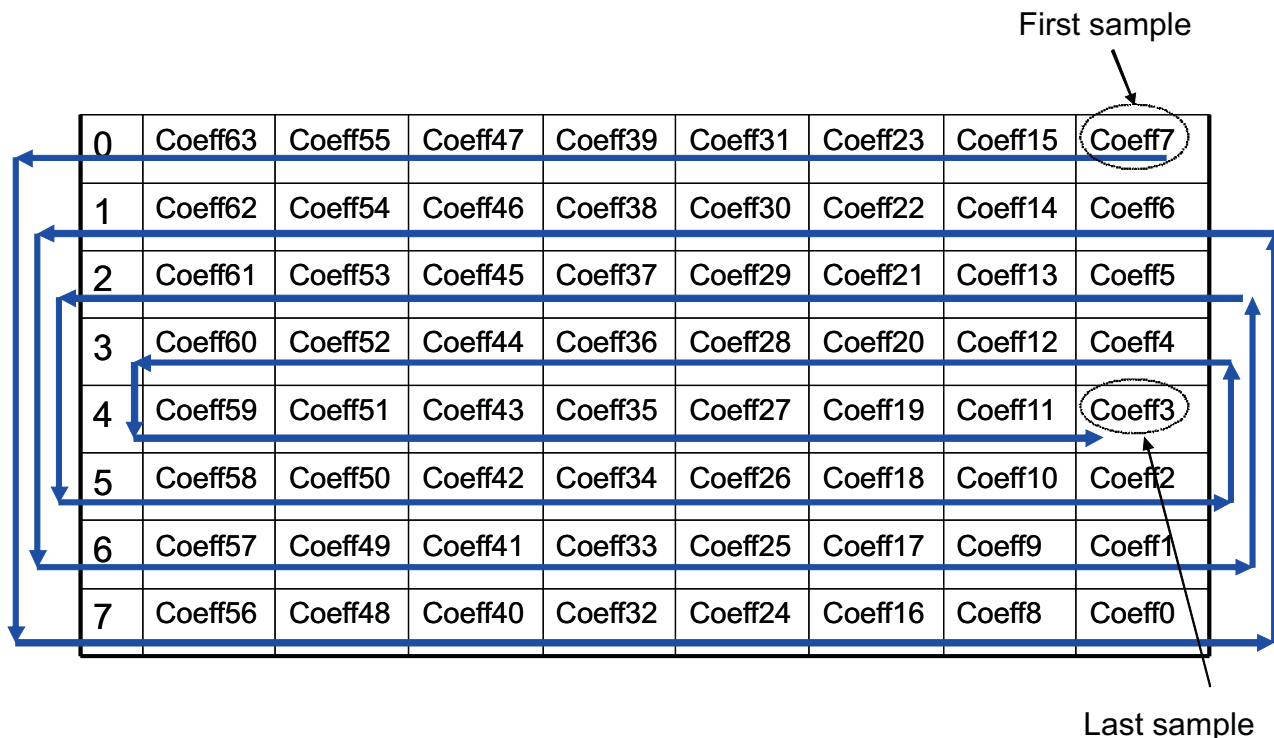

NOTE: When it reaches the last sample, it starts giving coefficients in the reverse direction until it reaches the point it started.

Figure 91. Coefficient Readout Sequence

8.6.2.1.5 TX\_SYNC and SYNC\_WORD Timing

As shown in Figure 92, hardware TX\_SYNC is latched at the next negative edge of the ADC Clock after 0 to 1 transition of TX\_SYNC. The time gap between latched edge and the start of the LVDS SYNC\_WORD is  $kT$  ns where  $T$  is the time period of ADC clock and  $k = 16 + \text{decFactor} + 1$ .  $t_{\text{SETUP}}$  and  $t_{\text{HOLD}}$  can be considered as 1.5 ns in the normal condition. Both are at the negative edge of the ADC clock.

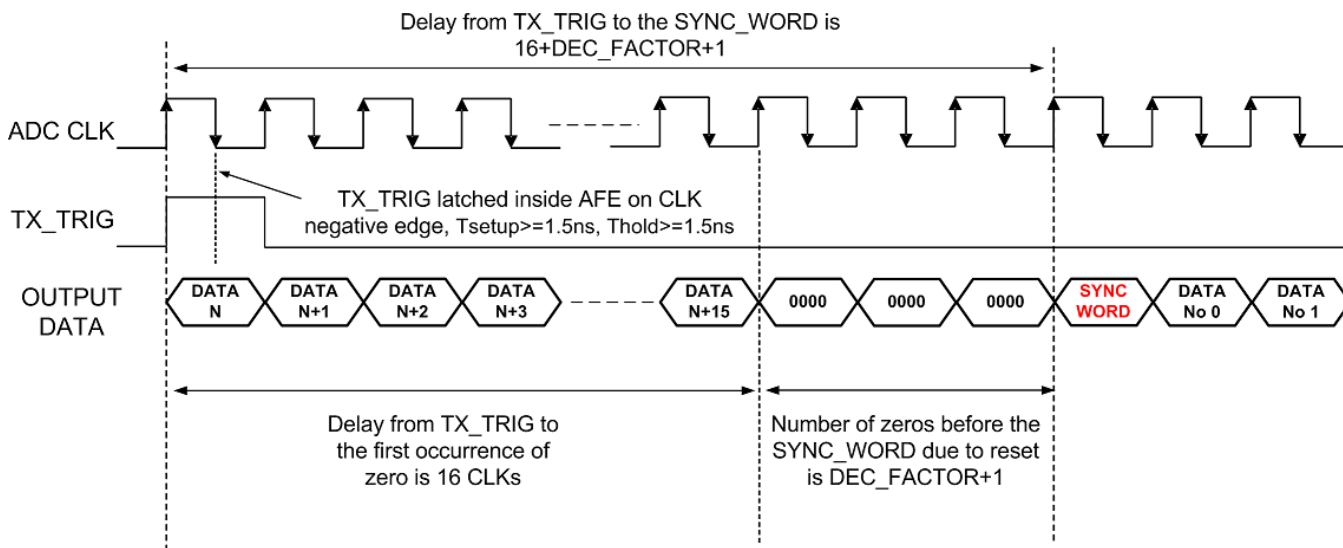

Figure 92. Sync Word Generation With Respect to TX\_TRIG when DC\_REMOVAL\_BYPASS 10[0] = 0

### 8.6.2.1.6 FIR Filter Delay versus TX\_TRIG Timing

The AFE5809 device's decimation filter is a symmetric Mx16-order FIR filter, where M is the decimation factor from 1 to 32. Half of the Mx16 coefficients are stored in the filter coefficient memory.

For a discrete-time FIR filter, its output is a weighted sum of the current and a finite number of previous values of the input as Equation 7 shows.

$$Y[n] = C_0 \times X[n] + C_1 \times X[n-1] \dots + C_N \times X[n-N]$$

where

- X[n] is the input signal.
- Y[n] is the output signal.
- CN is the filter coefficients.
- N is the filter order.

(7)

Therefore, the delay of the AFE5809 output is related to decimation factor, M. The TX\_TRIG timing also plays a role in this. In the following description, M = 1 and M = 2 are used as examples to derive a generic timing relationship among TX\_TRIG, AFE input, and AFE output.

The following register settings were used when the delay relationship was measured:

**Table 23. Settings for evaluating FIR Filter Delay versus TX\_TRIG Timing**

Register Setting	Register Setting (HEX)	Description
22[0] = 1	0x16[0] = 1	Enable demodulator. 0x16 belongs to ADC register
Profile RAM	Profile RAM	Set different decimation factor and other settings in profile RAM.
Coeff RAM	Coeff RAM	Write filter coefficients in coefficient memory.
29[7] = 1	0x1D[7] = 1	Set DEC_SHIFT_FORCE_EN
10[13] = 1	0xA[13] = 1	Set DEC_SHIFT_SCALE
29[6:4] = 6	0x1D[6:4] = 6	Set DEC_SHIFT_FORCE
10[15] = 0, 10[12] = 1, 10[4] = 1, 10[1] = 1;	0xA[15] = 0, 0xA[12] = 1, 0xA[4] = 1, 0xA[1] = 1	RESERVED bits
10[0] = 1	0x0A[0] = 1	Set DC_REMOVAL_BYPASS
10[10] = 1	0x0A[10] = 1	Reset down conversion phase on TX_TRIG
03[14:13] = 11	03[14:13] = 11	SERZ_FACTOR 16X
03[11:9] = 100	03[11:9] = 100	OUTPUT_RESOLUTION 16X
04[4] = 1	04[4] = 1	MSB_FIRST
11[15:0]	0xB[15:0]	Set custom SYNC_WORD value if needed
10[2]=0	0x0A[2]=0	Down conversion is enabled.
Profile RAM[21:6]=0	Profile RAM[21:6]=0	Down convert frequency set to 0, that is, multiply input signal with DC.
<b>Note:</b> Even if this frequency is set to a non-zero value, it will not change the demod latency. For experiment ease, mixing with DC is performed. ADC sampling frequency and VCA LPF settings were kept such that the AFE5809's demod sees a single pulse.		

When  $M = 1$ , 8 filter coefficients written in the memory are C0, C1 to C7. An impulse signal is applied at both VCA input and TX\_TRIG. Due to the impulse input, coefficients start coming at the output according to timing diagram shown in Figure 93, where 20-cycle delay is observed.

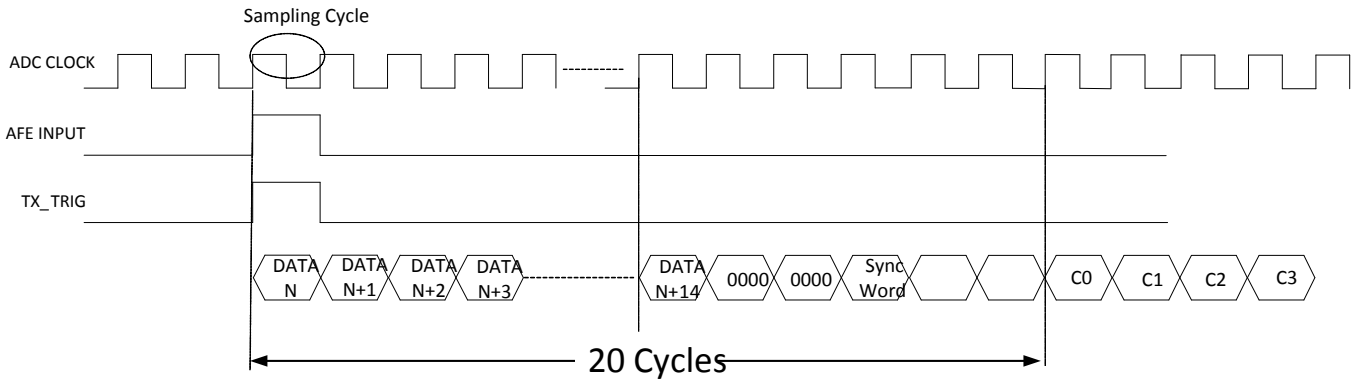

Figure 93. Expected Latency Timing When  $M = 1$

By adjusting the timing between AFE input and TX\_TRIG, the user can obtain a timing diagram similar to Figure 93.

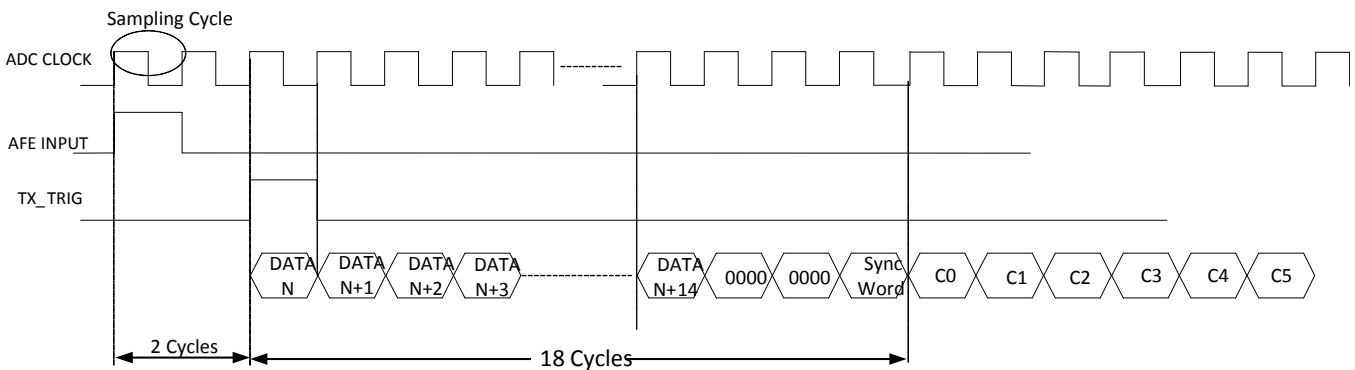

Figure 94. Measured Latency Timing When  $M = 1$

By adjusting the timing between AFE input and TX\_TRIG, the user can obtain a timing diagram similar to Figure 94.

When  $M = 2$ , if the impulse is given one clock before TX\_TRIG signal, then the demod output after sync word gives impulse response of the filter as shown in Figure 95.

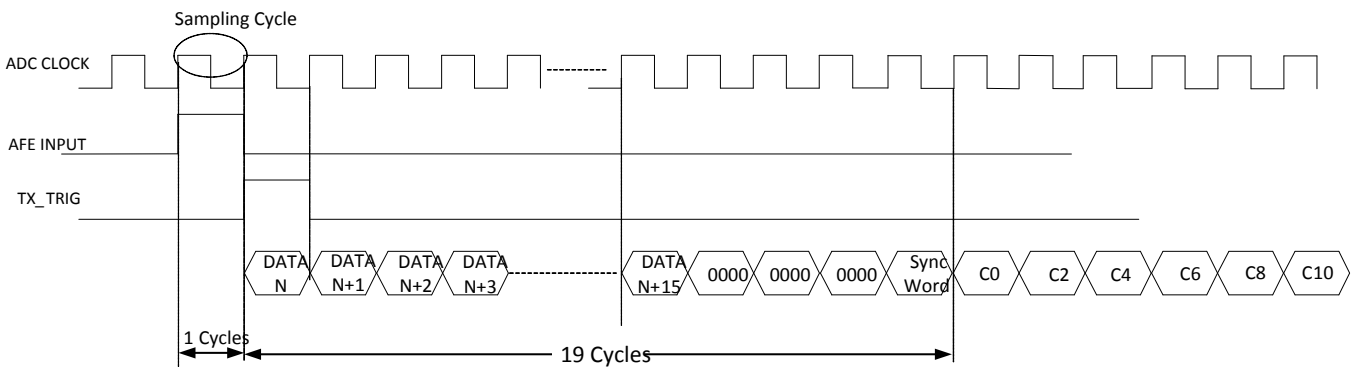

Figure 95. Measured Latency Timing When  $M = 2$

Figure 96 shows a generic timing diagram. The number of zeros comes before the sync word is equal to Z. The sync word comes after S number of cycles, impulse response starts coming after L number of cycles, and input impulse is given after IP cycles with respect to TX\_TRIG signal. Therefore, for different decimation factor (M), values of these numbers are listed in Table 24 and Figure 96.

**Table 24. Generic Latency versus Decimation Factor M<sup>(1)(2)</sup>**

M	Number of Zeros (ZNo)	Sync Word Latency (S)	Data Latency (L)	Input Impulse (IP) <sup>(3)</sup>
1	2	17	18	-2
2	3	18	19	-1
3	4	19	20	0
4	5	20	21	1
5	6	21	22	2
6	7	22	23	3
7	8	23	24	4
8	9	24	25	5
M	M + 1	16 + M	17 + M	M - 3

- (1) When DC\_REMOVAL\_BYPASS 10[0] = 0 or 0xA[0] = 0, the sync word latency and data latency becomes 17 + M and 18 + M
- (2) ADC's low latency mode enabled by register 0x2[12] does not impact S and L.
- (3) Negative number represents input is given in advance with respect to TX\_TRIG signal.

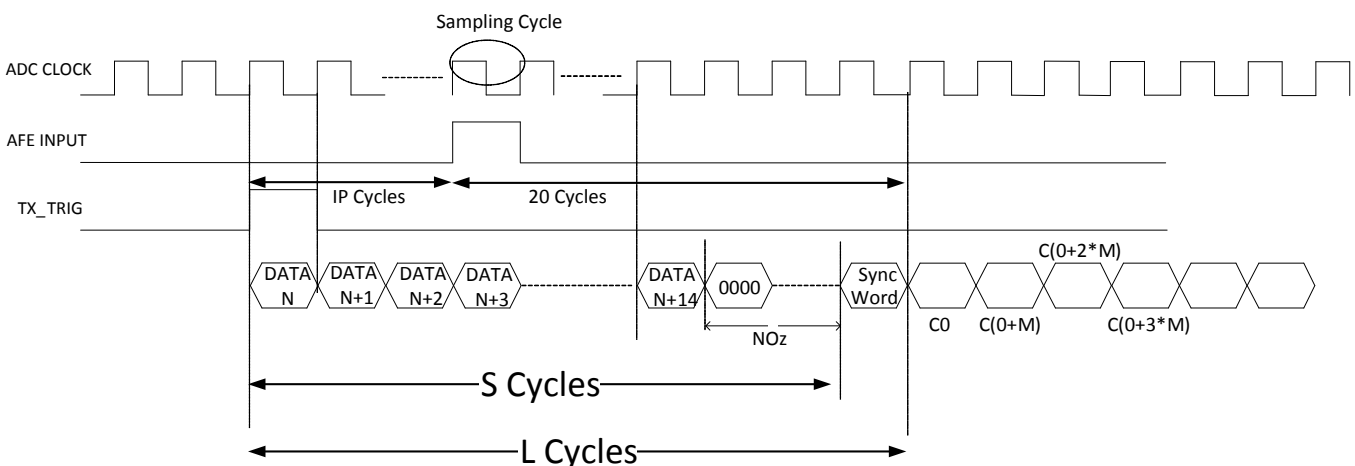

**Figure 96. Measured Latency Timing at Any M**

**8.6.2.1.6.0.1 Expression of Decimation Filter Response**

Based on Table 24, the decimation filter's response is formulated. Figure 97 indicates that the Tx\_Trig sample is considered as the reference for time scale. So, the input to the device at Tx\_Trig clock will be expressed as X[0], the next sample input as X[1], and so on. Similarly, the output of the device followed by the AFE5809's demodulator will be expressed as Y[0] at the instant of Tx\_Trig, Y[1] at the next clock, and so on; Cn or C(n) indicates the coefficient of n<sup>th</sup> index.

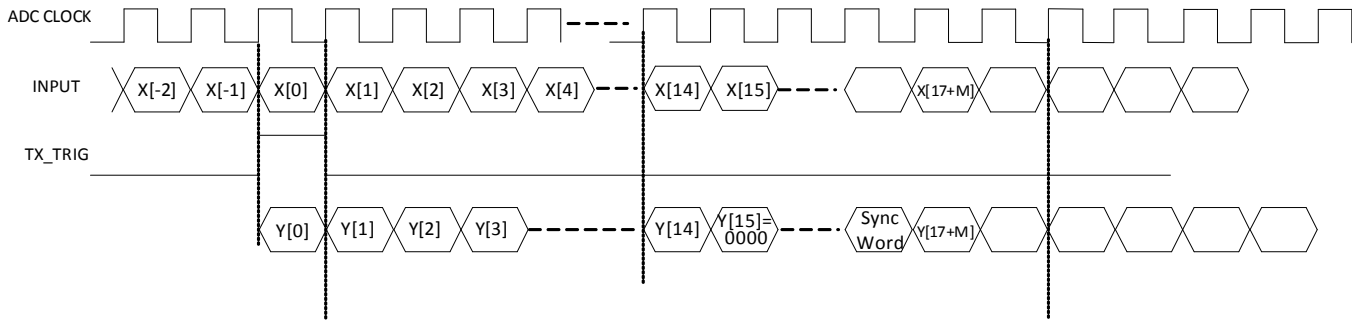

Figure 97. Typical Timing Expression Among ADC CLK, Input, TX\_TRIG, and Output

For  $M = 1$ , the number of zeros,  $ZNo = 2$ ; Sync word latency  $S = 17$ . So, the output values from sample 18 are relevant and the first few samples are:

$$\begin{aligned} Y[18] &= C0 \times X[-2] + C1 \times X[-3] + C2 \times X[-4] + \dots + C7 \times X[-9] + C7 \times X[-10] + \dots + C[0] \times X[-17] \\ Y[19] &= C0 \times X[-1] + C1 \times X[-2] + C2 \times X[-3] + \dots + C7 \times X[-8] + C7 \times X[-9] + \dots + C[0] \times X[-16] \\ Y[20] &= C0 \times X[0] + C1 \times X[-1] + C2 \times X[-2] + \dots + C7 \times X[-7] + C7 \times X[-8] + \dots + C[0] \times X[-15] \end{aligned} \quad (8)$$

All these samples appear at the output because no samples are dropped for decimation factor = 1.

For  $M = 2$ , the number of zeros,  $ZNo = 3$ ; Sync word latency  $S = 18$ . So, the output values from sample 19 are relevant and the first few samples are described as:

$$\begin{aligned} Y[19] &= C0 \times X[-1] + C1 \times X[-2] + C2 \times X[-3] + \dots + C15 \times X[-16] + C15 \times X[-17] + \dots + C[0] \times X[-32] \\ Y[20] &= C0 \times X[0] + C1 \times X[-1] + C2 \times X[-2] + \dots + C15 \times X[-15] + C15 \times X[-16] + \dots + C[0] \times X[-31] \\ Y[21] &= C0 \times X[1] + C1 \times X[0] + C2 \times X[-1] + \dots + C15 \times X[-14] + C15 \times X[-15] + \dots + C[0] \times X[-30] \end{aligned} \quad (9)$$

But for  $M = 2$ , every alternate sample must be dropped. The decimation is adjusted in such a way that the first sample after sync is retained. Hence in this case,  $Y[19]$ ,  $Y[21]$ ,  $Y[23]$ , and so forth are retained and  $Y[20]$ ,  $Y[22]$ ,  $Y[24]$ , and so forth are dropped.

For  $M = 3$ , the number of zeros,  $ZNo = 4$ ; Sync word latency  $S = 19$ . So, the output values from sample 20 are relevant and the first few samples are described as:

$$\begin{aligned} Y[20] &= C0 \times X[0] + C1 \times X[-1] + C2 \times X[-2] + \dots + C23 \times X[-23] + C23 \times X[-24] + \dots + C[0] \times X[-47] \\ Y[21] &= C0 \times X[1] + C1 \times X[0] + C2 \times X[-1] + \dots + C23 \times X[-22] + C23 \times X[-23] + \dots + C[0] \times X[-46] \\ Y[22] &= C0 \times X[2] + C1 \times X[1] + C2 \times X[0] + \dots + C23 \times X[-21] + C23 \times X[-22] + \dots + C[0] \times X[-45] \\ Y[23] &= C0 \times X[3] + C1 \times X[2] + C2 \times X[1] + \dots + C23 \times X[-20] + C23 \times X[-21] + \dots + C[0] \times X[-44] \end{aligned} \quad (10)$$

But for  $M = 3$ , the last two of every three samples must be dropped. The decimation is adjusted in such a way that the first sample after sync is retained. Hence in this case,  $Y[20]$ ,  $Y[23]$ ,  $Y[26]$ , and so forth are retained and  $Y[21]$ ,  $Y[22]$ ,  $Y[24]$ ,  $Y[25]$ , and so forth are dropped.

For any  $M$ , this pattern can be generalized for a decimation factor of  $M$ . The number of  $ZNo = M + 1$ , Sync word latency  $S = 16 + M$ . So, the output values from sample  $(17 + M)$  are relevant and the first few samples are described as:

$$\begin{aligned} Y[17+M] &= C0 \times X[M-3] + C1 \times X[M-4] + C2 \times X[M-5] + \dots + C(8M-1) \times X[-7M-2] + C(8M-1) \times X[-7M-3] + \dots + C[0] \times X[-15M-2] \\ Y[18+M] &= C0 \times X[M-2] + C1 \times X[M-3] + C2 \times X[M-4] + \dots + C(8M-1) \times X[-7M-1] + C(8M-1) \times X[-7M-2] + \dots + C[0] \times X[-15M-1] \end{aligned} \quad (11)$$

**AFE5809**

SLOS738E – SEPTEMBER 2012 – REVISED AUGUST 2015

[www.ti.com](http://www.ti.com)

For a decimation factor of  $M$  which is not 1, the decimation is adjusted in such a way that the first sample after sync is retained. Hence in this case,  $Y[17 + M]$ ,  $Y[17 + 2M]$ ,  $Y[17 + 3M]$ , and so forth are retained and the rest of samples between these, that is,  $Y[18 + M]$ ,  $Y[19 + 2M]$ , ...,  $Y[16 + 2M]$  are dropped.

## 9 Application and Implementation

### NOTE

Information in the following applications sections is not part of the TI component specification, and TI does not warrant its accuracy or completeness. TI's customers are responsible for determining suitability of components for their purposes. Customers should validate and test their design implementation to confirm system functionality.

### 9.1 Application Information

[Figure 98](#) lists a typical application circuit diagram. The configuration for each block is discussed in the following sections. lists companion TI devices to complete the analog signal chain in a system.

**Table 25. Application Companion Devices**

Part Number	Part Description	Functions
THS4130, <a href="#">SLOS318</a>	Fully Differential Input/Output Low Noise Amplifier With Shutdown	TGC Vcntl Opamp, CW summing amplifier and active filter
OPA1632, <a href="#">SBOS286</a>	Fully Differential I/O Audio Amplifier	TGC Vcntl amplifier, CW summing amplifier and active filter
OPA2211A, <a href="#">SBOS377</a>	1.1nV/rtHz Noise, Low Power, Precision Operational Amplifier	CW summing amplifier and active filter
LME49990, <a href="#">SNOSB16</a>	Ultra-low Distortion, Ultra-low Noise Operational Amplifier	CW summing amplifier and active filter
LMH6629, <a href="#">SNOSB18</a>	Ultra-Low Noise, High-Speed Operational Amplifier with Shutdown	CW summing amplifier and active filter
ADS8413, <a href="#">SLAS490</a>	16-bit, Unipolar Diff Input, 2MSPS Sampling rate, 4.75V to 5.25V ADC with LVDS Serial Interface	CW Audio ADC
ADS8881, <a href="#">SBAS547</a>	18-Bit, 1-MSPS, Serial Interface, microPower, Truly-Differential Input, SAR ADC	CW Audio ADC
DAC7811, <a href="#">SBAS337</a>	12-Bit, Serial Input, Multiplying Digital to Analog Converter	TGC Vcntl Digital to Analog Converter
LMK04803, <a href="#">SNAS489</a>	Low Noise Clock Jitter Cleaner With Dual Cascaded PLLs and Integrated 1.9 GHz VCO	Jitter cleaner and clock synthesizer
CDCM7005, <a href="#">SCAS793</a>	High Performance, Low Phase Noise, Low Skew Clock Synchronizer	Jitter cleaner and clock synthesizer
CDCE72010, <a href="#">SLAS490</a>	10 Outputs Low Jitter Clock Synchronizer and Jitter Cleaner	Jitter cleaner and clock synthesizer
CDCLVP1208, <a href="#">SCAS890</a>	Low Jitter, 2-Input Selectable 1:8 Universal-to-LVPECL Buffer	Clock buffer
LMK00308, <a href="#">SNAS576</a>	3.1-GHz Differential Clock Buffer/Level Translator	Clock buffer
LMK01000, <a href="#">SNAS437</a>	1.6 GHz High Performance Clock Buffer, Divider, and Distributor	Clock buffer
SN74AUP1T04, <a href="#">SCES800</a>	Low Power, 1.8/2.5/3.3-V Input, 3.3-V CMOS Output, Single Inverter Gate	1.8V/2.5V/3.3V Level shifter for SPI
UCC28250, <a href="#">SLUSA29</a>	Advanced PWM Controller with Prebias Operation	Synchronized DC-DC power supply controller

9.2 Typical Application

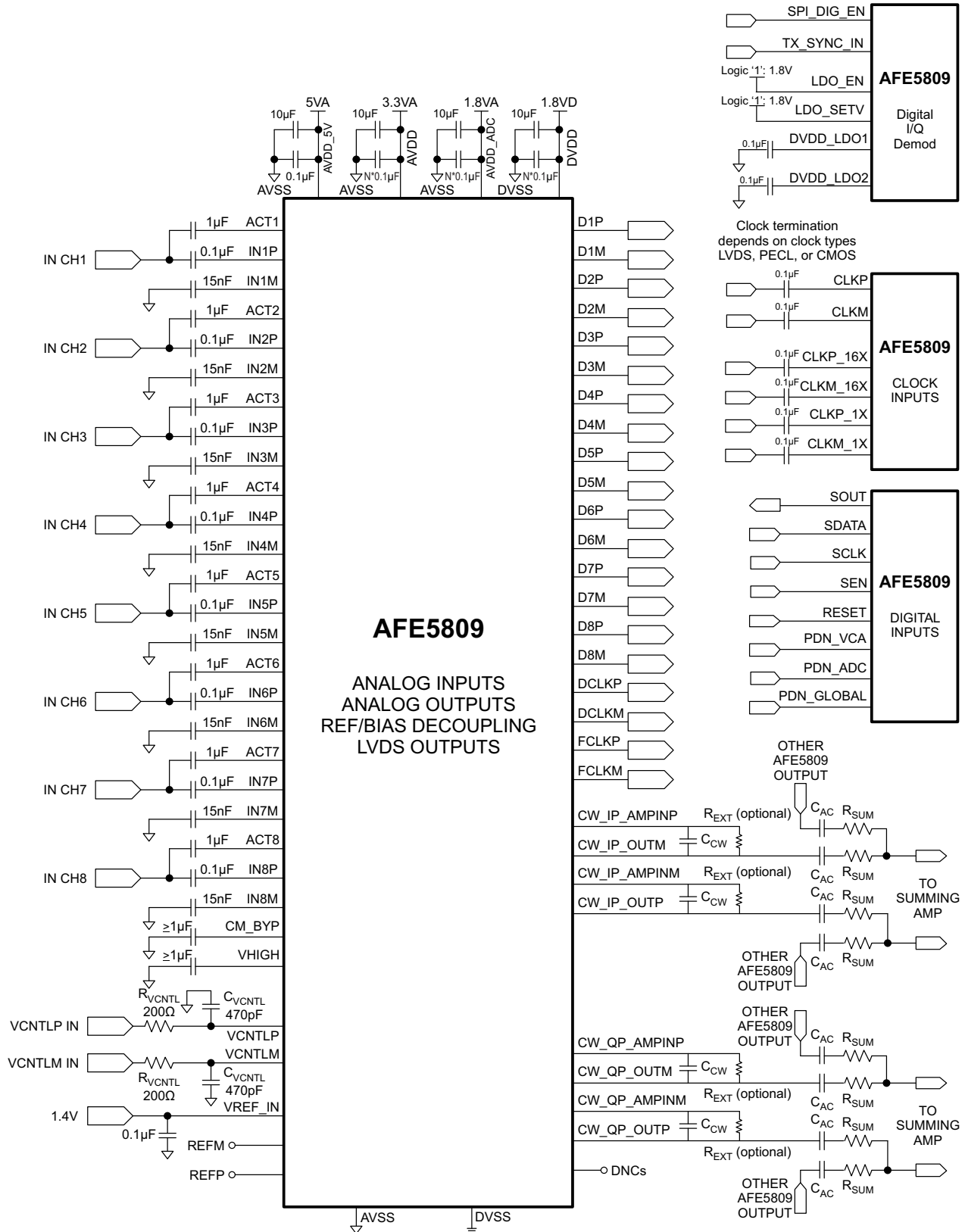

Figure 98. Application Circuit With Digital Demodulator

## Typical Application (continued)

### 9.2.1 Design Requirements

The AFE5809 device is a highly integrated analog front-end solution. To maximize its performance, users must carefully optimize its surrounding circuits, such as T/R switch, Vcntl circuits, audio ADCs for CW path, clock distribution network, synchronized power supplies and digital processors. Typical requirements for a traditional medical ultrasound imaging system are shown in [Table 26](#).

**Table 26. Design Parameters**

PARAMETER	EXAMPLE VALUES
Signal center frequency (f0)	1~20 MHz
Signal Bandwidth (BW)	10~100% of f0
Overloaded signals due to T/R switch leakage	~2 Vpp
Maximum input signal amplitude	100 mVpp to 1 Vpp
Transducer noise level	1 nV/rtHz
Dynamic range	151 dBc/Hz
Time gain compensation range	40 dB
Total harmonic distortion	40 dBc at 5MHz

### 9.2.2 Detailed Design Procedure

Medical ultrasound imaging is a widely-used diagnostic technique that enables visualization of internal organs, their size, structure, and blood flow estimation. An ultrasound system uses a focal imaging technique that involves time shifting, scaling, and intelligently summing the echo energy using an array of transducers to achieve high imaging performance. The concept of focal imaging provides the ability to focus on a single point in the scan region. By subsequently focusing at different points, an image is assembled.

When initiating an imaging, a pulse is generated and transmitted from each of the 64 transducer elements. The pulse, now in the form of mechanical energy, propagates through the body as sound waves, typically in the frequency range of 1MHz to 15 MHz. The sound waves are attenuated as they travel through the objects being imaged, and the attenuation coefficients  $\alpha$  are about 0.54 dB/(MHz $\times$ cm) in soft tissue and 6~10 dB/(MHz $\times$ cm) in bone as shown in many published papers. Most medical ultrasound systems use the reflection imaging mode and the total signal attenuation is calculated by  $2 \times \text{depth} \times \alpha \times f_0$ . As the signal travels, portions of the wave front energy are reflected. Signals that are reflected immediately after transmission are very strong because they are from reflections close to the surface; reflections that occur long after the transmit pulse are very weak because they are reflecting from deep in the body. As a result of the limitations on the amount of energy that can be put into the imaging object, the industry developed extremely sensitive receive electronics with wide dynamic range.

Receive echoes from focal points close to the surface require little, if any, amplification. This region is referred to as the near field. However, receive echoes from focal points deep in the body are extremely weak and must be amplified by a factor of 100 or more. This region is referred to as the far field. In the high-gain (far field) mode, the limit of performance is the sum of all noise sources in the receive chain. In high-gain (far field) mode, system performance is defined by its overall noise level, which is limited by the noise level of the transducer assembly and the receive low-noise amplifier (LNA). However in the low-gain (near field) mode, system performance is defined by the maximum amplitude of the input signal that the system can handle. The ratio between noise levels in high-gain mode and the signal amplitude level in low-gain mode is defined as the dynamic range of the system. The high integration and high dynamic range of the device make it ideally suited for ultrasound imaging applications.

The device includes an integrated LNA and VCAT (which use the gain that can be changed with enough time to handle both near- and far-field systems), a low-pass anti-aliasing filter to limit the noise bandwidth, an ADC with high SNR performance, and a CW mixer.

Use the following steps to design medical ultrasound imaging systems:

1. Use the signal center frequency and signal bandwidth to select an appropriate ADC sampling frequency.
2. Use the time gain compensation range to select the range of the VCNTL signal.
3. Use the transducer noise level and maximum input signal amplitude to select the appropriate LNA gain. The device input-referred noise level reduces with higher LNA gain. However, higher LNA gain leads to lower

input signal swing support.

4. Select different passive components for different device pins.
5. Select the appropriate input termination configuration.
6. Select the clock configuration for the ADC and CW clocks

**9.2.2.1 LNA Configuration**

**9.2.2.1.1 LNA Input Coupling and Decoupling**

The LNA closed-loop architecture is internally compensated for maximum stability without the need of external compensation components. The LNA inputs are biased at 2.4 V and AC coupling is required. Figure 99 shows a typical input configuration.  $C_{IN}$  is the input AC coupling capacitor.  $C_{ACT}$  is a part of the active termination feedback path. Even if the active termination is not used, the  $C_{ACT}$  is required for the clamp functionality. The recommended values for  $C_{ACT}$  is  $\geq 1 \mu\text{F}$  and  $C_{IN}$  is  $\geq 0.1 \mu\text{F}$ . A pair of clamping diodes is commonly placed between the T/R switch and the LNA input. Schottky diodes with suitable forward drop voltage (for example: the BAT754/54 series, the BAS40 series, the MMBD7000 series, or similar) can be considered depending on the transducer echo amplitude.

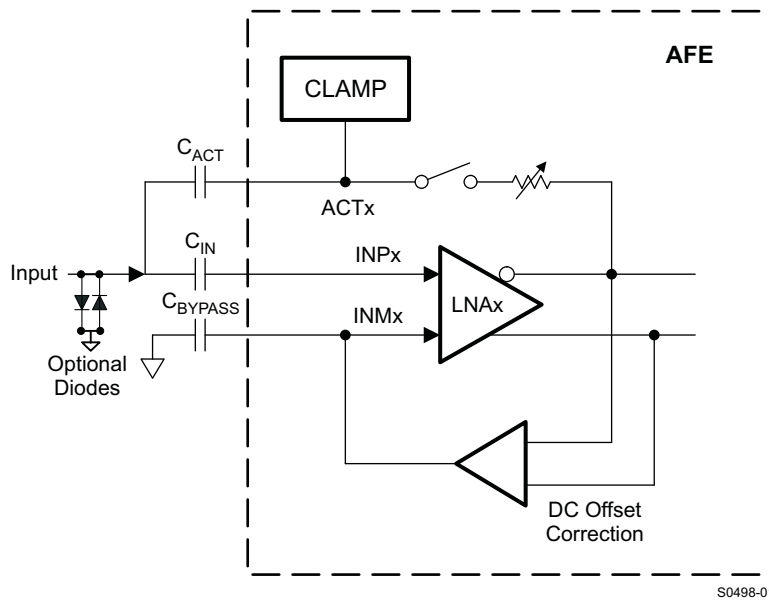

**Figure 99. LNA Input Configurations**

This architecture minimizes any loading of the signal source that may lead to a frequency-dependent voltage divider. The closed-loop design yields low offsets and offset drift.  $C_{BYPASS}$  ( $\geq 0.015 \mu\text{F}$ ) is used to set the HPF cut-off frequency and decouple the complementary input. Its cut-off frequency is inversely proportional to the  $C_{BYPASS}$  value. The HPF cut-off frequency can be adjusted through the register 59[3:2] Table 27 lists. Low-frequency signals at T/R switch output, such as signals with slow ringing, can be filtered out. In addition, the HPF can minimize system noise from DC-DC converters, pulse repetition frequency (PRF) trigger, and frame clock. Most ultrasound systems' signal-processing unit includes digital HPFs or band-pass filters (BPFs) in FPGAs or ASICs. Further noise suppression can be achieved in these blocks. In addition, a digital HPF is available in the AFE5809 ADC. If low-frequency signal detection is desired in some applications, the LNA HPF can be disabled.

**Table 27. LNA HPF Settings ( $C_{BYPASS} = 15 \text{ nF}$ )**

Reg59[3:2] (0x3B[3:2])	FREQUENCY (kHz)
00	100
01	50
10	200
11	150

CM\_BYP and VHIGHS pins, which generate internal reference voltages, must be decoupled with  $\geq 1\text{-}\mu\text{F}$  capacitors. Bigger bypassing capacitors ( $>2.2\ \mu\text{F}$ ) may be beneficial if low-frequency noise exists in the system.

### 9.2.2.1.2 LNA Noise Contribution

The noise specification is critical for LNA and it determines the dynamic range of the entire system. The LNA of the AFE5809 device achieves low power and an exceptionally low-noise voltage of  $0.63\ \text{nV}/\sqrt{\text{Hz}}$ , and a low current noise of  $2.7\ \text{pA}/\sqrt{\text{Hz}}$ .

Typical ultrasonic transducer's impedance,  $R_s$ , varies from tens of  $\Omega$  to several hundreds of  $\Omega$ . Voltage noise is the dominant noise in most cases; however, the LNA current noise flowing through the source impedance ( $R_s$ ) generates additional voltage noise.

$$\text{LNA\_Noise}_{\text{total}} = \sqrt{V_{\text{LNAnoise}}^2 + R_s^2 \times I_{\text{LNAnoise}}^2} \quad (12)$$

The AFE5809 device achieves low-noise figure (NF) over a wide range of source resistances as shown in [Figure 32](#), [Figure 33](#), and [Figure 34](#).

### 9.2.2.1.3 Active Termination

In ultrasound applications, signal reflection exists due to long cables between the transducer and system. The reflection results in extra ringing added to echo signals in PW mode. Because the axial resolution depends on echo signal length, such ringing effect can degrade the axial resolution. Therefore, either passive termination or active termination is preferred if good axial resolution is desired. [Figure 100](#) shows three termination configurations.

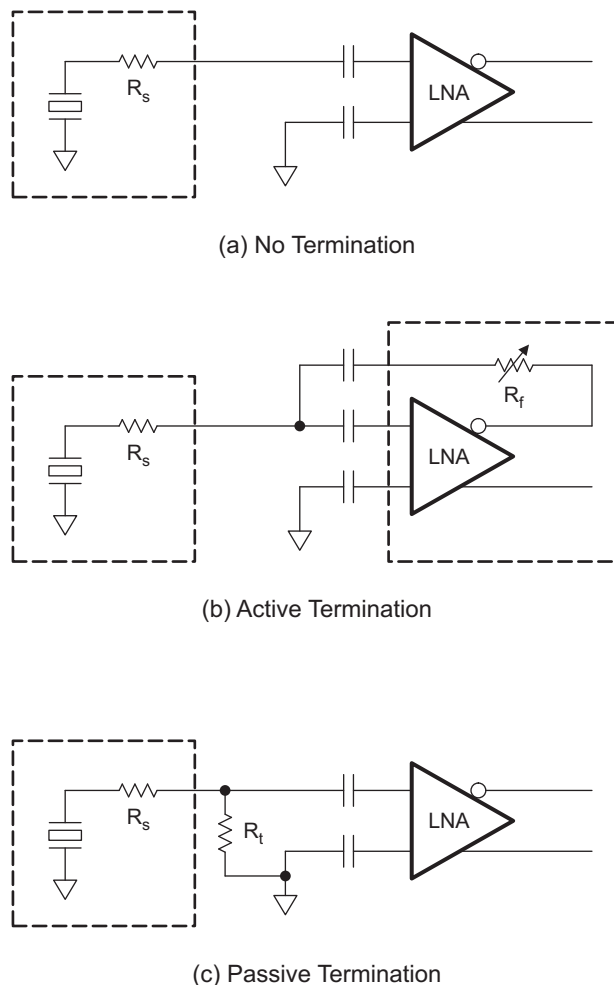

S0499-01

**Figure 100. Termination Configurations**

Under the no termination configuration, the input impedance of the AFE5809 is about 6 k $\Omega$  (8 K//20 pF) at 1 MHz. Passive termination requires external termination resistor  $R_t$ , which contributes to additional thermal noise.

The LNA supports active termination with programmable values, as shown in [Figure 101](#).

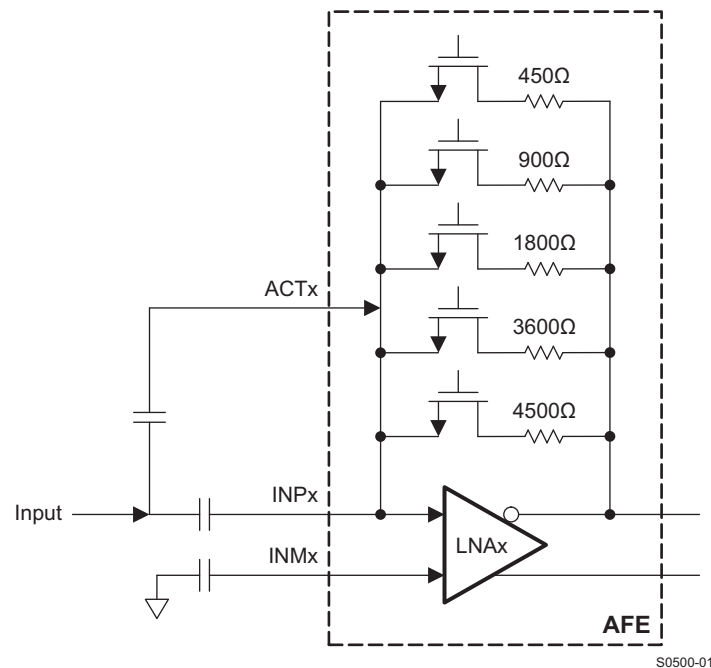

**Figure 101. Active Termination Implementation**

The AFE5809 device has four pre-settings 50, 100, 200, and 400  $\Omega$ , which are configurable through the registers. Other termination values can be realized by setting the termination switches shown in [Figure 101](#). Register [52] is used to enable these switches. The input impedance of the LNA under the active termination configuration approximately follows:

$$Z_{IN} = \frac{R_f}{1 + \frac{A_{V_{LNA}}}{2}} \quad (13)$$

[Table 5](#) lists the LNA  $R_{IN}$ s under different LNA gains. System designers can achieve fine tuning for different probes.

The equivalent input impedance is given by [Equation 14](#) where  $R_{IN}$  (8 k $\Omega$ ) and  $C_{IN}$  (20 pF) are the input resistance and capacitance of the LNA.

$$Z_{IN} = \frac{R_f}{1 + \frac{A_{V_{LNA}}}{2}} // C_{IN} // R_{IN} \quad (14)$$

Therefore, the  $Z_{IN}$  is frequency dependent, and it decreases as frequency increases as shown in [Figure 10](#). Because 2 to 10 MHz is the most commonly used frequency range in medical ultrasound, this rolling-off effect does not impact system performance greatly. Active termination can be applied to both CW and TGC modes. Because each ultrasound system includes multiple transducers with different impedances, the flexibility of impedance configuration is a great plus.

[Figure 32](#), [Figure 33](#), and [Figure 34](#) show the NF under different termination configurations. It indicates that no termination achieves the best noise figure; active termination adds less noise than passive termination. Thus, termination topology should be carefully selected based on each use scenario in ultrasound.

9.2.2.1.4 LNA Gain Switch Response

The LNA gain is programmable through SPI. The gain switching time depends on the SPI speed as well as the LNA gain response time. During the switching, glitches might occur and they can appear as artifacts in images. In addition, the signal chain needs about 14 μs to settle after the LNA gain change. Thus, LNA gain switching may not be preferred when switching time or settling time for the signal chain is limited.

9.2.2.2 Voltage-Controlled Attenuator

The attenuator in the AFE5809 device is controlled by a pair of differential control inputs, the  $V_{CNTLM,P}$  pins. The differential control voltage spans from 0 to 1.5 V. This control voltage varies the attenuation of the attenuator based on its linear-in-dB characteristic. Its maximum attenuation (minimum channel gain) appears at  $V_{CNTLP} - V_{CNTLM} = 1.5$  V and minimum attenuation (maximum channel gain) occurs at  $V_{CNTLP} - V_{CNTLM} = 0$ . The typical gain range is 40 dB and remains constant, independent of the PGA setting.

When only single-ended  $V_{CNTL}$  signal is available, this 1.5-Vpp signal can be applied on the  $V_{CNTLP}$  pin with the  $V_{CNTLM}$  pin connected to ground; As Figure 102 show, the TGC gain curve is inversely proportional to the  $V_{CNTLP} - V_{CNTLM}$ .

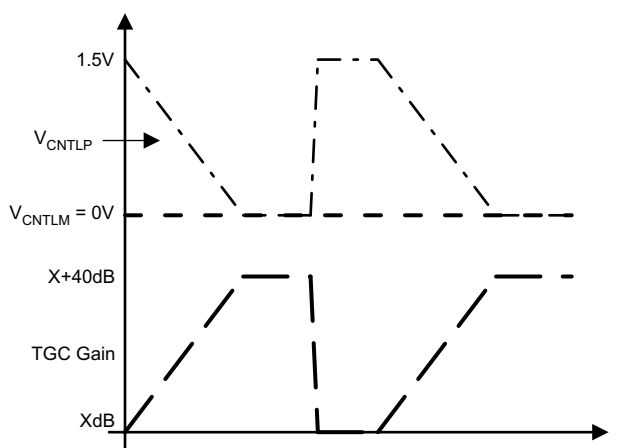

(a) Single-Ended Input at  $V_{CNTLP}$

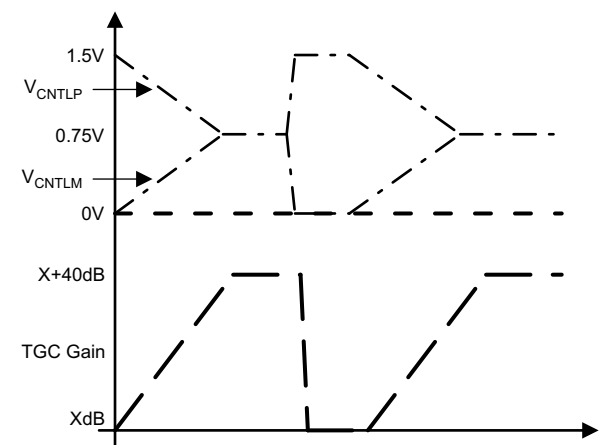

(b) Differential Inputs at  $V_{CNTLP}$  and  $V_{CNTLM}$

W0004-01

Figure 102.  $V_{CNTLP}$  and  $V_{CNTLM}$  Configurations

As discussed in the theory of operation, the attenuator architecture uses seven attenuator segments that are equally spaced to approximate the linear-in-dB gain-control slope. This approximation results in a monotonic slope; the gain ripple is typically less than  $\pm 0.5$  dB.

The control voltage input ( $V_{\text{CNTLM,P}}$  pins) represents a high-impedance input. The  $V_{\text{CNTLM,P}}$  pins of multiple AFE5809 devices can be connected in parallel with no significant loading effects. When the voltage level ( $V_{\text{CNTLP}} - V_{\text{CNTLM}}$ ) is above 1.5 V or below 0 V, the attenuator continues to operate at its maximum attenuation level or minimum attenuation level, respectively. TI recommends limiting the voltage from  $-0.3$  to 2 V.

When the AFE5809 device operates in CW mode, the attenuator stage remains connected to the LNA outputs. Therefore, TI recommends powering down the VCA using the PDN\_VCA register bit. In this case,  $V_{\text{CNTLP}} - V_{\text{CNTLM}}$  voltage does not matter.

The AFE5809 gain-control input has a  $-3$ -dB bandwidth of approximately 800 kHz. This wide bandwidth, although useful in many applications (for example, fast  $V_{\text{CNTL}}$  response), can also allow high-frequency noise to modulate the gain control input and finally affect the Doppler performance. In practice, this modulation can be avoided by additional external filtering ( $RV_{\text{CNTL}}$  and  $CV_{\text{CNTL}}$ ) at  $V_{\text{CNTLM,P}}$  pins as Figure 81 shows. However, the external filter's cutoff frequency cannot be kept too low as this results in low gain response time. Without external filtering, the gain control response time is typically less than 1  $\mu\text{s}$  to settle within 10% of the final signal level of 1VPP ( $-6$ -dBFS) output as indicated in Figure 51 and Figure 52.

Typical  $V_{\text{CNTLM,P}}$  signals are generated by an 8- to 12-bit 10-MSPS digital-to-analog converter (DAC) and a differential operation amplifier. TI's DACs, such as TLV5626 and DAC7821/11 (10 MSPS/12 bit), could be used to generate TGC control waveforms. Differential amplifiers with output common mode voltage control (that is, THS4130 and OPA1632) can connect the DAC to the  $V_{\text{CNTLM,P}}$  pins. The buffer amplifier can also be configured as an active filter to suppress low-frequency noise. The  $V_{\text{CNTLM,P}}$  circuit achieves low noise to prevent the  $V_{\text{CNTLM,P}}$  noise being modulated to RF signals. TI recommends that  $V_{\text{CNTLM,P}}$  noise is below 25 nV/rtHz at 1 kHz and 5 nV/rtHz at 50 kHz. In high-channel count premium systems, the  $V_{\text{CNTLM,P}}$  noise requirement is higher. See Figure 103

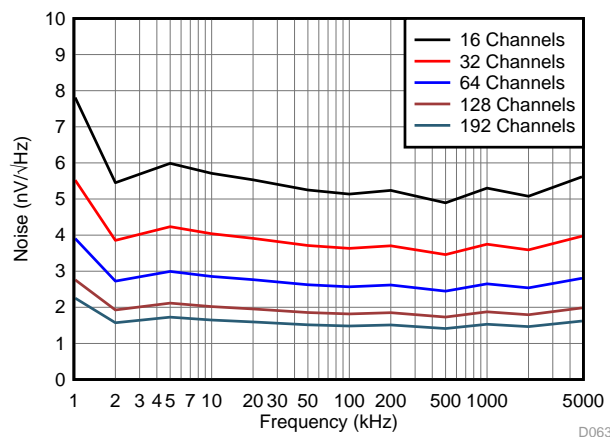

**Figure 103. Allowed Noise on the VCNTL Signal Across Frequency and Different Channels**

More information can be found in SLOS318 and SBAA150. See Figure 2 for the  $V_{\text{CNTL}}$  vs Gain curves. Table 28 also shows the absolute gain vs  $V_{\text{CNTL}}$ , which may help program DAC correspondingly.

In PW Doppler and color Doppler modes,  $V_{\text{CNTL}}$  noise should be minimized to achieve the best close-in phase noise and SNR. Digital  $V_{\text{CNTL}}$  feature is implemented to address this need in the AFE5809. In the digital  $V_{\text{CNTL}}$  mode, no external  $V_{\text{CNTL}}$  is needed.

**Table 28.  $V_{\text{CNTLP}} - V_{\text{CNTLM}}$  vs Gain Under Different LNA and PGA Gain Settings (Low-Noise Mode)**

$V_{\text{CNTLP}} - V_{\text{CNTLM}}$ (V)	Gain (dB) LNA = 12 dB PGA = 24 dB	Gain (dB) LNA = 18 dB PGA = 24 dB	Gain (dB) LNA = 24 dB PGA = 24 dB	Gain (dB) LNA = 12 dB PGA = 30 dB	Gain (dB) LNA = 18 dB PGA = 30 dB	Gain (dB) LNA = 24 dB PGA = 30 dB
0	36.45	42.45	48.45	42.25	48.25	54.25
0.1	33.91	39.91	45.91	39.71	45.71	51.71
0.2	30.78	36.78	42.78	36.58	42.58	48.58
0.3	27.39	33.39	39.39	33.19	39.19	45.19
0.4	23.74	29.74	35.74	29.54	35.54	41.54
0.5	20.69	26.69	32.69	26.49	32.49	38.49
0.6	17.11	23.11	29.11	22.91	28.91	34.91
0.7	13.54	19.54	25.54	19.34	25.34	31.34
0.8	10.27	16.27	22.27	16.07	22.07	28.07
0.9	6.48	12.48	18.48	12.28	18.28	24.28
1	3.16	9.16	15.16	8.96	14.96	20.96
1.1	-0.35	5.65	11.65	5.45	11.45	17.45
1.2	-2.48	3.52	9.52	3.32	9.32	15.32
1.3	-3.58	2.42	8.42	2.22	8.22	14.22
1.4	-4.01	1.99	7.99	1.79	7.79	13.79
1.5	-4	2	8	1.8	7.8	13.8

### 9.2.2.3 CW Operation

#### 9.2.2.3.1 CW Summing Amplifier

To simplify CW system design, a summing amplifier is implemented in the AFE5809 to sum and convert 8-channel mixer current outputs to a differential voltage output. Low noise and low power are achieved in the summing amplifier while maintaining the full dynamic range required in CW operation.

This summing amplifier has five internal gain adjustment resistors which can provide 32 different gain settings (register 54[4:0], [Figure 101](#) and [Table 8](#)). System designers can easily adjust the CW path gain depending on signal strength and transducer sensitivity. For any other gain values, an external resistor option is supported. The gain of the summation amplifier is determined by the ratio between the 500-Ω resistors after LNA and the internal or external resistor network  $R_{\text{EXT/INT}}$ . Thus, the matching between these resistors plays a more important role than absolute resistor values. Better than 1% matching is achieved on chip. Due to process variation, the absolute resistor tolerance could be higher. If external resistors are used, the gain error between I/Q channels or among multiple AFEs may increase. TI recommends using internal resistors to set the gain to achieve better gain matching (across channels and multiple AFEs). With the external capacitor  $C_{\text{EXT}}$ , this summing amplifier has first-order LPF response to remove high-frequency components from the mixers, such as  $2f_0 \pm fd$ . Its cut-off frequency is determined by:

$$f_{\text{HP}} = \frac{1}{2\pi R_{\text{INT/EXT}} C_{\text{EXT}}} \quad (15)$$

When different gain is configured through Register 54[4:0], the LPF response varies as well.

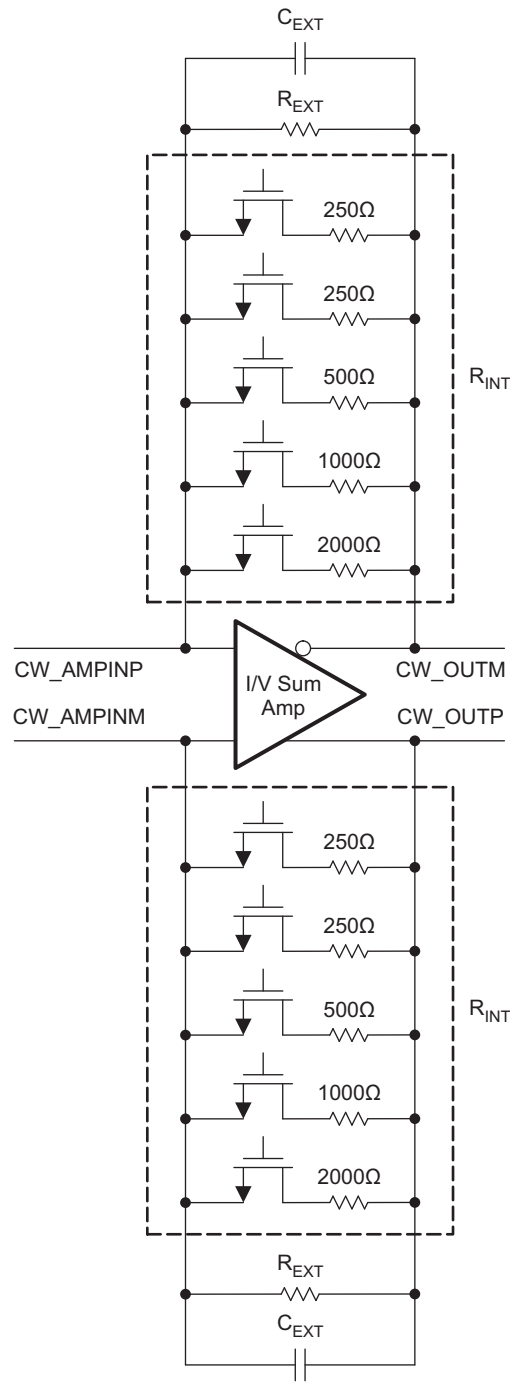

S0501-01

**Figure 104. CW Summing Amplifier Block Diagram**

Multiple AFE5809 devices are usually used in parallel to expand CW beamformer channel count. The AFE5809 CW's voltage outputs can be summed and filtered externally further to achieve desired gain and filter response. AC-coupling capacitors  $C_{AC}$  are required to block the DC component of the CW carrier signal.  $C_{AC}$  can vary from 1 to 10  $\mu\text{F}$  depending on the desired low-frequency Doppler signal from slow blood flow. Multiple AFE5809s' I/Q outputs can be summed together with a low-noise differential amplifiers before 16, 18-bit differential audio ADCs. The TI ultralow noise differential precision amplifier OPA1632 and THS4130 are suitable devices.

Figure 106 shows an alternative current summing circuit. However, this circuit only achieves good performance when a lower-noise operational amplifier is available compared to the AFE5809's internal summing differential amplifier.

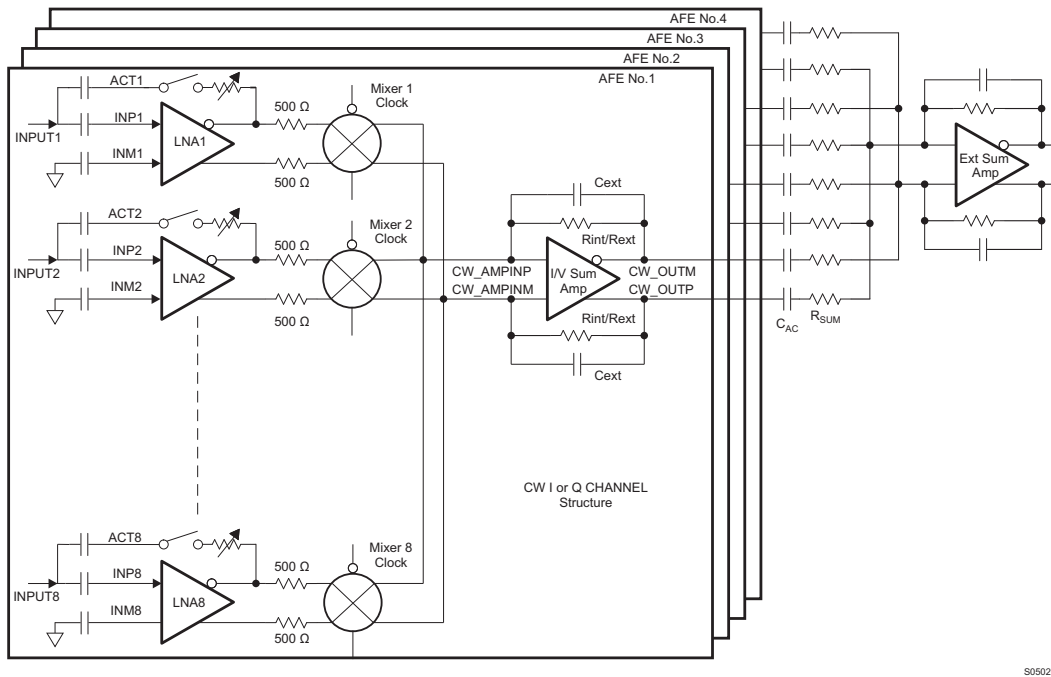

Figure 105. CW Circuit With Multiple AFE5809s (Voltage Output Mode)

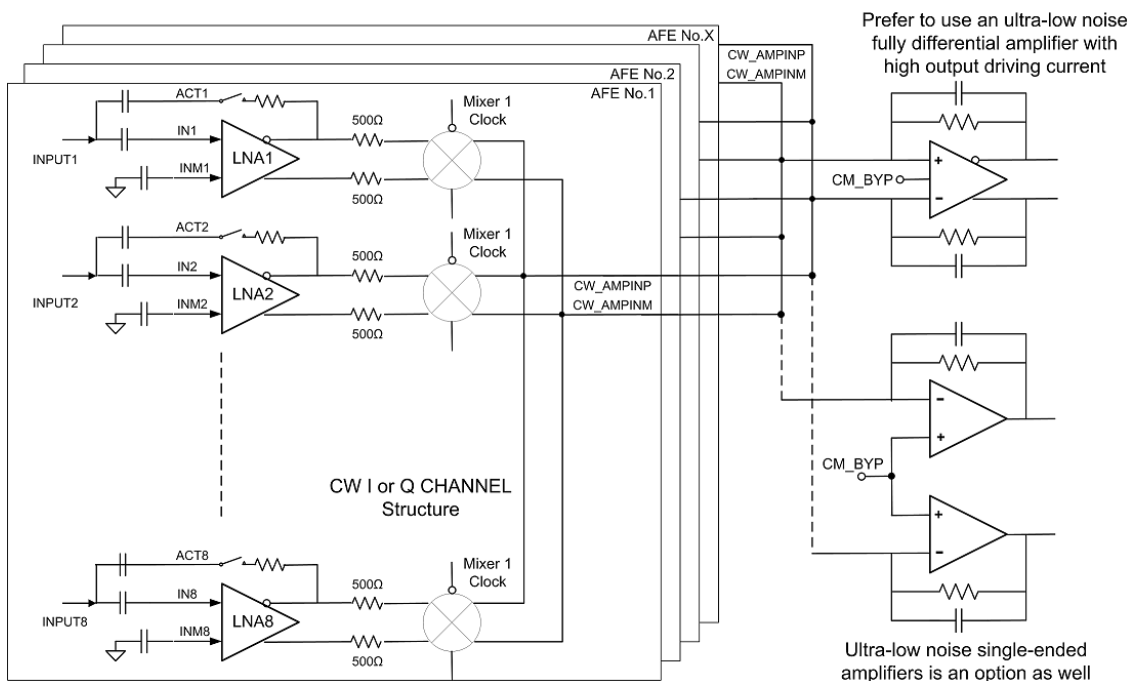

Figure 106. CW Circuit With Multiple AFE5809s (Current Output Mode, CM\_BYP=1.5 V)

The CW I/Q channels are well matched internally to suppress image frequency components in the Doppler spectrum. Low-tolerance components and precise operational amplifiers should be used for achieving good matching in the external circuits as well.

**NOTE**

The local oscillator inputs of the passive mixer are  $\cos(\omega t)$  for I-CH and  $\sin(\omega t)$  for Q-CH, respectively. Depending on the users' CW Doppler complex FFT processing, swapping I/Q channels in FPGA or DSP may be needed to get correct blood flow directions.

**9.2.2.3.2 CW Clock Selection**

The AFE5809 device can accept differential LVDS, LVPECL, and other differential clock inputs as well as single-ended CMOS clock. An internally generated VCM of 2.5 V is applied to CW clock inputs, that is, CLKP\_16X/CLKM\_16X and CLKP\_1X/CLKM\_1X. Because this 2.5-V VCM is different from the one used in standard LVDS or LVPECL clocks, AC coupling is required between clock drivers and the AFE5809 CW clock inputs. When the CMOS clock is used, CLKM\_1X and CLKM\_16X should be tied to ground. Figure 107 shows common clock configurations. TI recommends appropriate termination to achieve good signal integrity.

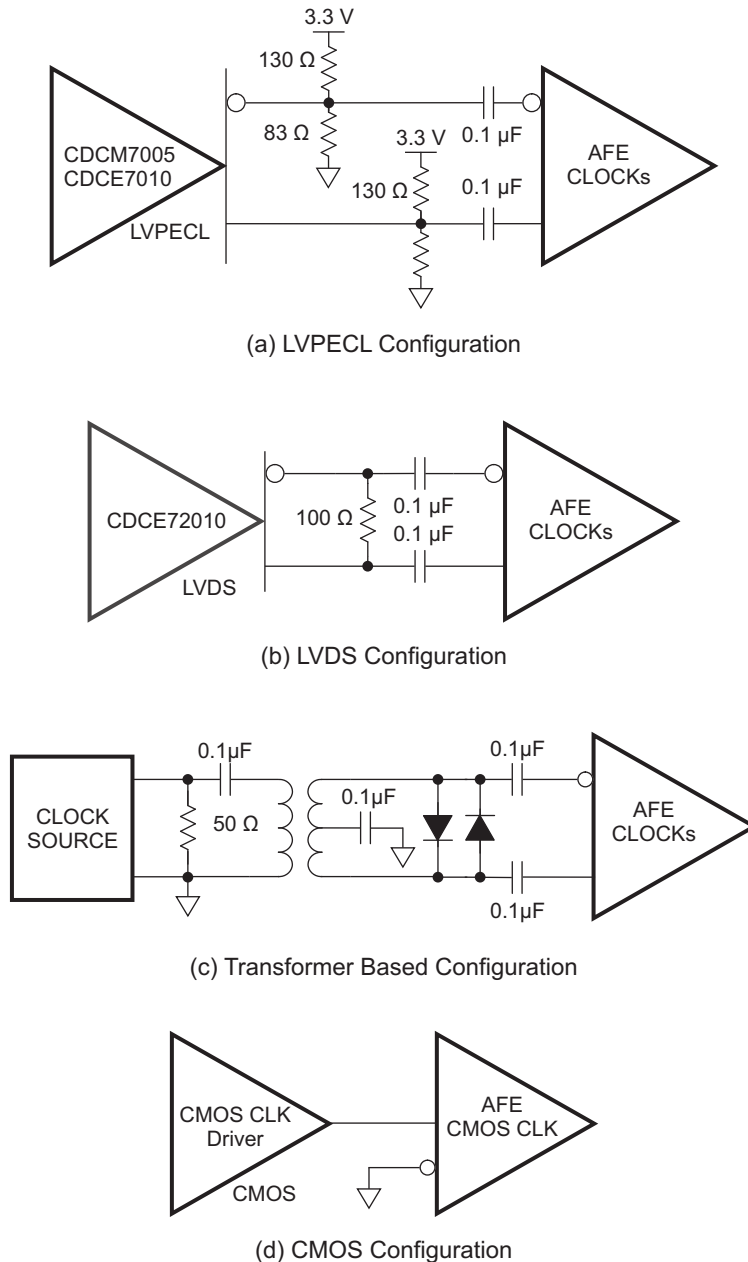

S0503-01

**Figure 107. Clock Configurations**

The combination of the clock noise and the CW path noise can degrade the CW performance. The internal clocking circuit is designed for achieving excellent phase noise required by CW operation. The phase noise of the AFE5809 CW path is better than 155 dBc/Hz at 1-kHz offset. Consequently, the phase noise of the mixer clock inputs needs to be better than 155 dBc/Hz.

In the  $16/8/4 \times f_{CW}$  operations modes, low phase noise clock is required for  $16, 8, 4 \times f_{CW}$  clocks (that is, CLKP\_16X/ CLKM\_16X pins) to maintain good CW phase noise performance. The  $1 \times f_{CW}$  clock (that is, CLKP\_1X/ CLKM\_1X pins) is only used to synchronize the multiple AFE5809 chips and is not used for demodulation. Thus,  $1 \times f_{CW}$  clock's phase noise is not a concern. However, in the  $1 \times f_{CW}$  operation mode, low-phase noise clocks are required for both CLKP\_16X/ CLKM\_16X and CLKP\_1X/ CLKM\_1X pins because both of them are used for mixer demodulation. In general, a higher slew rate clock has lower phase noise; thus, clocks with high amplitude and fast slew rate are preferred in CW operation. In the CMOS clock mode, a 5-V CMOS clock can achieve the highest slew rate.

Clock phase noise can be improved by a divider as long as the divider's phase noise is lower than the target phase noise. The phase noise of a divided clock can be improved approximately by a factor of  $20\log N$  dB where N is the dividing factor of 16, 8, or 4. If the target phase noise of mixer LO clock  $1 \times f_{CW}$  is 160 dBc/Hz at 1 kHz off carrier, the  $16 \times f_{CW}$  clock phase noise should be better than  $160 - 20\log 16 = 136$  dBc/Hz. TI's jitter cleaners LMK048X/CDCM7005/CDCE72010 exceed this requirement and can be selected for the AFE5809. In the  $4 \times / 1 \times$  modes, higher-quality input clocks are expected to achieve the same performance because N is smaller. Thus, the  $16 \times$  mode is a preferred mode because it reduces the phase noise requirement for system clock design. In addition, the phase delay accuracy is specified by the internal clock divider and distribution circuit. Note in the  $16 \times$  operation mode, the CW operation range is limited to 8 MHz due to the  $16 \times$  CLK. The maximum clock frequency for the  $16 \times$  CLK is 128 MHz. In the  $8 \times, 4 \times,$  and  $1 \times$  modes, higher CW signal frequencies up to 15 MHz can be supported with small degradation in performance, for example, the phase noise is degraded by 9 dB at 15 MHz, compared to 2 MHz.

As the channel number in a system increases, clock distribution becomes more complex. It is not preferred to use one clock driver output to drive multiple AFEs because the clock buffer's load capacitance increases by a factor of N. As a result, the falling and rising time of a clock signal is degraded. A typical clock arrangement for multiple AFE5809 devices is shown in [Figure 108](#). Each clock buffer output drives one AFE5809 device to achieve the best signal integrity and fastest slew rate, that is, better phase noise performance. When clock phase noise is not a concern, for example, the  $1 \times f_{CW}$  clock in the  $16, 8, 4 \times f_{CW}$  operation modes, one clock driver output may excite more than one AFE5809 device. Nevertheless, special considerations should be applied in such a clock distribution network design. In typical ultrasound systems, it is preferred that all clocks are generated from a same clock source, such as  $16 \times f_{CW}, 1 \times f_{CW}$  clocks, audio ADC clocks, RF ADC clock, pulse repetition frequency signal, frame clock, and so on. By doing this, interference due to clock asynchronization can be minimized.

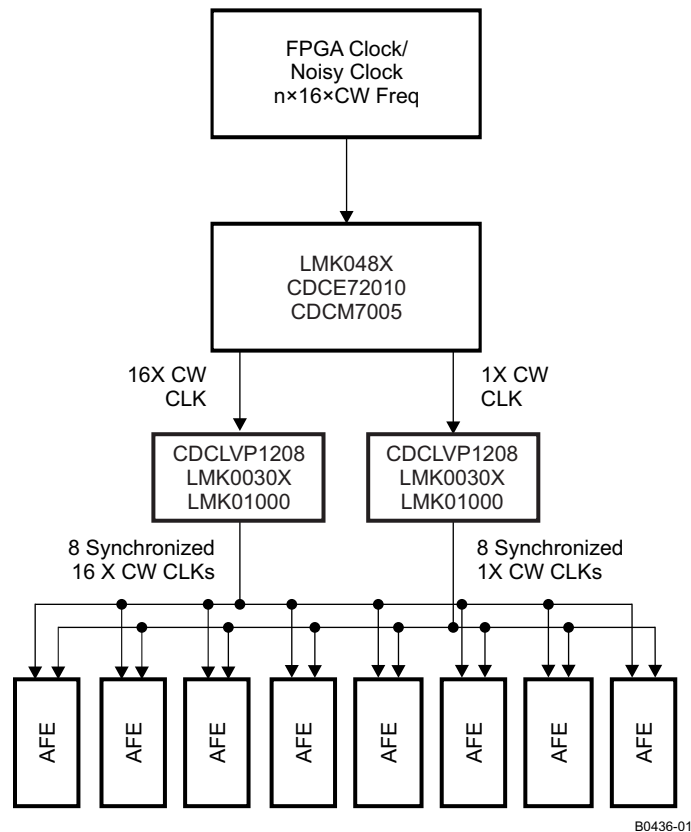

**Figure 108. CW Clock Distribution**

### 9.2.2.3.3 CW Supporting Circuits

As a general practice in CW circuit design, in-phase and quadrature channels should be strictly symmetrical by using well-matched layout and high-accuracy components.

In systems, additional high-pass wall filters (20 to 500 Hz) and low-pass audio filters (10 to 100 kHz) with multiple poles are usually needed. Because the CW Doppler signal ranges from 20 Hz to 20 kHz, noise under this range is critical. Consequently, low-noise audio operational amplifiers are suitable to build these active filters for CW post-processing, that is, OPA1632 or OPA2211. To find more filter design techniques, see [www.ti.com](http://www.ti.com). For the TI active filter design tool, see [www.ti.com/filterdesigner](http://www.ti.com/filterdesigner).

The filtered audio CW I/Q signals are sampled by audio ADCs and processed by DSP or PC. Although CW signal frequency is from 20 Hz to 20 kHz, higher sampling rate ADCs are still preferred for further decimation and SNR enhancement. Due to the large dynamic range of CW signals, high resolution ADCs ( $\geq 16$  bit) are required, such as ADS8413 (2 MSPS, 16-bit, 92-dBFS SNR) and ADS8472 (1 MSPS, 16-bit, 95-dBFS SNR). ADCs for in-phase and quadrature-phase channels must be strictly matched, not only amplitude matching but also phase matching, to achieve the best I/Q matching. In addition, the in-phase and quadrature ADC channels must be sampled simultaneously.

### 9.2.2.4 Low Frequency Support

In addition, the signal chain of the AFE5809 can handle signal frequency lower than 100 kHz, which enables the AFE5809 to be used in both sonar and medical applications. The PGA integrator must be turned off to enable the low frequency support. Meanwhile, a large capacitor like 1  $\mu$ F can be used for setting low corner frequency of the LNA DC offset correction circuit as shown in [Figure 62](#). See [Figure 59](#) to find AFE5809's low frequency response.

### 9.2.2.5 ADC Operation

#### 9.2.2.5.1 ADC Clock Configurations

To ensure that the aperture delay and jitter are the same for all channels, the AFE5809 uses a clock tree network to generate individual sampling clocks for each channel. The clock, for all the channels, are matched from the source point to the sampling circuit of each of the eight internal ADCs. The variation on this delay is described in the aperture delay parameter of the output interface timing. Its variation is given by the aperture jitter number of the same table.

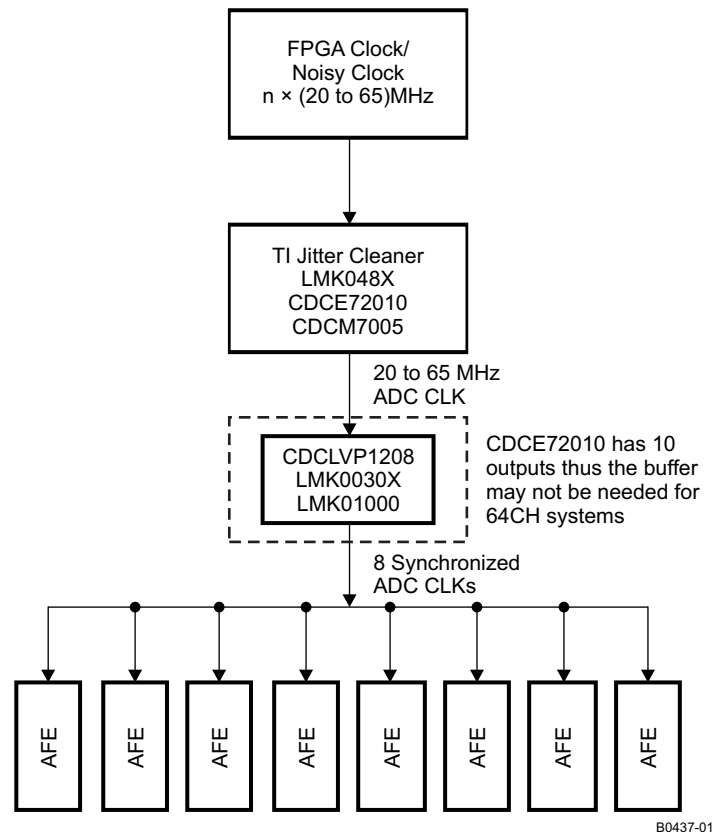

Figure 109. ADC Clock Distribution Network

The AFE5809 ADC clock input can be driven by differential clocks (sine wave, LVPECL, or LVDS) or singled clocks (LVCMOS) similar to CW clocks as shown in Figure 107. In the single-end case, TI recommends that the use of low jitter square signals (LVCMOS levels, 1.8-V amplitude). See TI document SLYT075 for further details on the theory.

The jitter cleaner CDCM7005 or CDCE72010 is suitable to generate the AFE5809's ADC clock and ensure the performance for the 14-bit ADC with 77-dBFS SNR. Figure 109 shows a clock distribution network.

#### 9.2.2.5.2 ADC Reference Circuit

The ADC's voltage reference can be generated internally or provided externally. When the internal reference mode is selected, the REFP/M become output pins and should be floated. When 3[15] = 1 and 1[13] = 1, the device is configured to operate in the external reference mode in which the VREF\_IN pin should be driven with a 1.4-V reference voltage and REFP/M must be left open. Because the input impedance of the VREF\_IN is high, no special drive capability is required for the 1.4-V voltage reference

The digital beam-forming algorithm in an ultrasound system relies on gain matching across all receiver channels. A typical system would have about 12 octal AFEs on the board. In such a case, it is critical to ensure that the gain is matched, essentially requiring the reference voltages seen by all the AFEs to be the same. Matching references within the eight channels of a chip is done by using a single internal reference voltage buffer. Trimming the reference voltages on each chip during production ensures that the reference voltages are well-matched across different chips. When the external reference mode is used, a solid reference plane on a PCB can ensure minimal voltage variation across devices. More information on voltage reference design can be found in the document [SLYT339](#).

The dominant gain variation in the AFE5809 comes from the VCA gain variation. The gain variation contributed by the ADC reference circuit is much smaller than the VCA gain variation. Hence, in most systems, using the ADC internal reference mode is sufficient to maintain good gain matching among multiple AFE5809s. In addition, the internal reference circuit without any external components achieves satisfactory thermal noise and phase noise performance.

### 9.2.3 Application Curves

Figure 110 show the output SNR of one AFE channel from  $V_{CNTL} = 0\text{ V}$  and  $V_{CNTL} = 1.2\text{ V}$ , respectively, with an input signal at 5 MHz captured at a sample rate of 65 MHz.  $V_{CNTL} = 0\text{ V}$  represents far field while  $V_{CNTL} = 1.2\text{ V}$  represents near field. Figure 111 shows the CW phase noise or dynamic range of a single AFE channel.

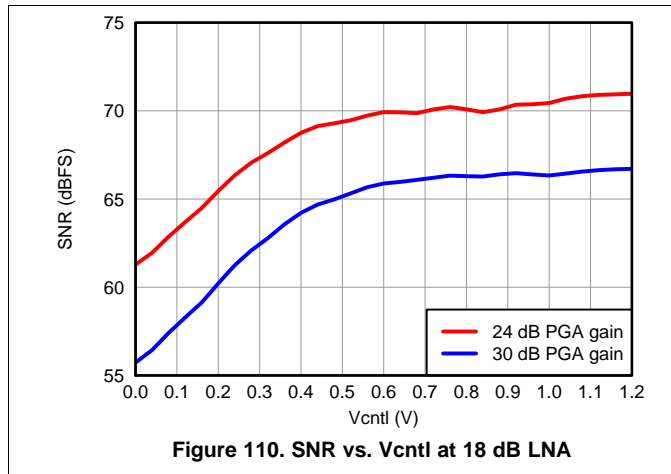

Figure 110. SNR vs. Vcntl at 18 dB LNA

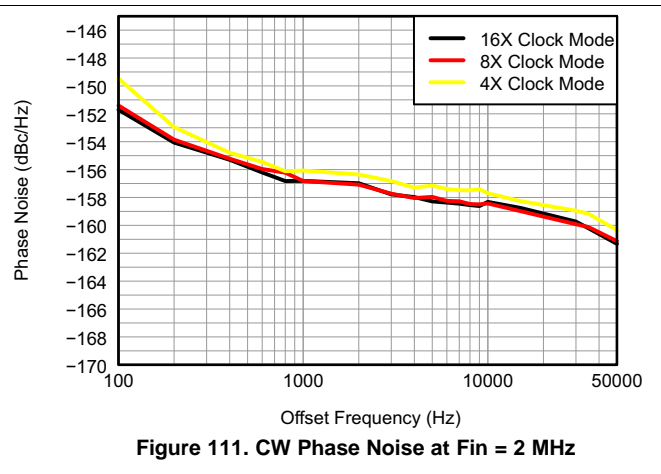

Figure 111. CW Phase Noise at  $F_{in} = 2\text{ MHz}$

## 9.3 System Example

In a complex system design, system debug features of a device are very important. The AFE5809 includes multiple test modes to accelerate system development.

### 9.3.1 ADC Debug

The ADC test modes are discussed in the ADC register description section. The AFE5809 device can output a variety of test patterns on the LVDS outputs. These test patterns replace the normal ADC data output. The device may also be made to output 6 preset patterns:

- Ramp: Setting Register 2[15:13] = 111 causes all the channels to output a repeating full-scale ramp pattern. The ramp increments from zero code to full-scale code in steps of 1 LSB every clock cycle. After hitting the full-scale code, it returns back to zero code and ramps again.
- Zeros: The device can be programmed to output all 0 s by setting Register 2[15:13] = 110.
- Ones: The device can be programmed to output all 1 s by setting Register 2[15:13] = 100.
- Deskew Patten: When 2[15:13] = 010; this mode replaces the 14-bit ADC output with the 01010101010101 word.
- Sync Pattern: When 2[15:13] = 001, the normal ADC output is replaced by a fixed 11111110000000 word.
- Toggle: When 2[15:13] = 101, the normal ADC output is alternating from 1 s to 0 s. The start state of ADC word can be either 1 s or 0 s.
- Custom Pattern: It can be enabled when 2[15:13] = 011. Users can write the required VALUE into register bits

### System Example (continued)

<CUSTOM PATTERN>, which is Register 5[13:0]. Then, the device will output VALUE at its outputs, about 3 to 4 ADC clock cycles after the 24<sup>th</sup> rising edge of SCLK. So, the time taken to write one value is 24 SCLK clock cycles + 4 ADC clock cycles. To change the customer pattern value, users can repeat writing Register 5[13:0] with a new value. Due to the speed limit of SPI, the refresh rate of the custom pattern may not be high. For example, 128 points custom pattern takes approximately  $128 \times (24 \text{ SCLK clock cycles} + 4 \text{ ADC clock cycles})$ .

---

#### NOTE

Only one of the above patterns can be active at any given instant. Test pattern from the ADC output stage can NOT be sent to the demodulator; it can only be sent to the LVDS serializer when the demodulator is off.

---

#### NOTE

After the demodulator is enabled, digital demodulator register 02[15:13] can be configured to send out test patterns for demod block, please see [Digital Demodulator Register Description](#).

---

### 9.3.2 VCA Debug

The VCA has a test mode in which the CH7 and CH8 PGA outputs can be brought to the CW pins. By monitoring these PGA outputs, the functionality of VCA operation can be verified. The PGA outputs are connected to the virtual ground pins of the summing amplifier (CW\_IP\_AMPINM/P, CW\_QP\_AMPINM/P) through 5-k $\Omega$  resistors. The PGA outputs can be monitored at the summing amplifier outputs when the LPF capacitors C<sub>EXT</sub> are removed. The signals at the summing amplifier outputs are attenuated due to the 5-k $\Omega$  resistors. The attenuation coefficient is  $R_{\text{INT/EXT}} / 5 \text{ k}\Omega$ .

If users would like to check the PGA outputs without removing C<sub>EXT</sub>, an alternative way is to measure the PGA outputs directly at the CW\_IP\_AMPINM/P and CW\_QP\_AMPINM/P when the CW summing amplifier is powered down.

Some registers are related to this test mode, PGA Test Mode Enable: Reg59[9]; Buffer Amplifier Power Down Reg59[8]; and Buffer Amplifier Gain Control Reg54[4:0]. Based on the buffer amplifier configuration, the registers can be set in different ways:

- Configuration 1
  - In this configuration, the test outputs can be monitored at CW\_AMPINP/M.
  - Reg59[9] = 1; test mode enabled
  - Reg59[8] = 0; buffer amplifier powered-down
- Configuration 2
  - In this configuration, the test outputs can be monitored at CW\_OUTP/M.
  - Reg59[9] = 1; test mode enabled
  - Reg59[8] = 1; buffer amplifier powered on
  - Reg54[4:0] = 10H; internal feedback 2-k $\Omega$  resistor enabled. Different values can be used as well.

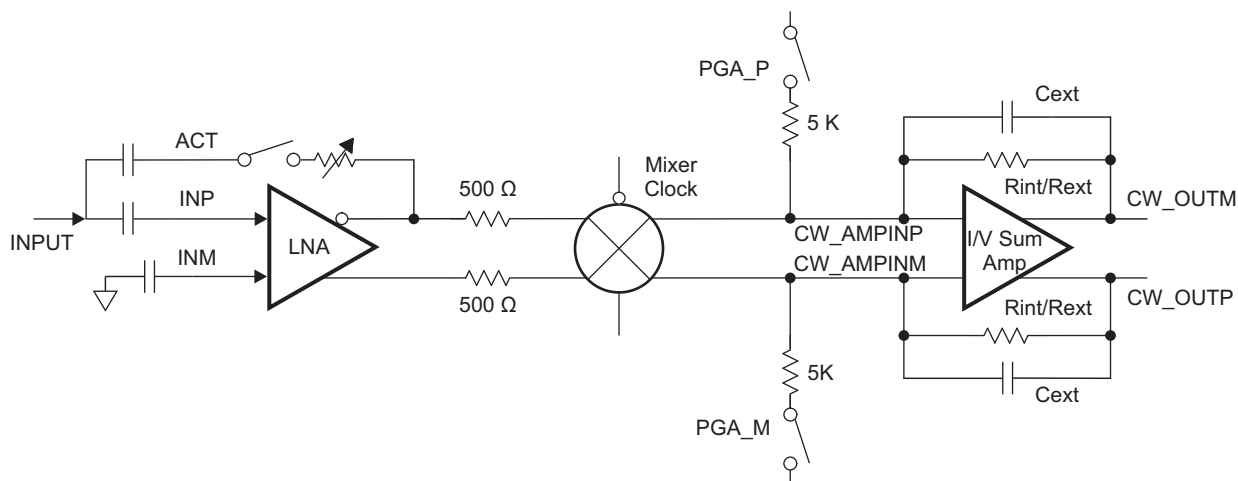
**System Example (continued)**

S0504-01

**Figure 112. AFE5809 PGA Test Mode**
**9.4 Do's and Don'ts**
**9.4.1 Driving the Inputs (Analog or Digital) Beyond the Power-Supply Rails**

For device reliability, an input must not go more than 300 mV below the ground pins or 300 mV above the supply pins as suggested in the table. Exceeding these limits, even on a transient basis, can cause faulty or erratic operation and can impair device reliability.

**9.4.2 Driving the Device Signal Input With an Excessively High Level Signal**

The device offers consistent and fast overload recovery with a 6-dB overloaded signal. For very large overload signals (> 6 dB of the linear input signal range), TI recommends back-to-back Schottky clamping diodes at the input to limit the amplitude of the input signal. Refer to the section for more details.

**9.4.3 Driving the VCNTL Signal With an Excessive Noise Source**

Noise on the VCNTL signal gets directly modulated with the input signal and causes higher output noise and reduction in SNR performance. Maintain a noise level for the VCNTL signal as discussed in the section.

**9.4.4 Using a Clock Source With Excessive Jitter, an Excessively Long Input Clock Signal Trace, or Having Other Signals Coupled to the ADC or CW Clock Signal Trace**

These situations cause the sampling interval to vary, causing an excessive output noise and a reduction in SNR performance. For a system with multiple devices, the clock tree scheme must be used to apply an ADC or CW clock. Refer to the section for clock mismatch between devices, which can lead to latency mismatch and reduction in SNR performance. Clocks generated by FPGA may include excessive jitter and must be evaluated carefully before driving ADC or CW circuits.

**9.4.5 LVDS Routing Length Mismatch**

The routing length of all LVDS lines routing to the FPGA must be matched to avoid any timing related issue. For systems with multiple devices, the LVDS serialized data clock (DCLKP, DCLKM) and the frame clock (FCLKP, FCLKM) of each individual device must be used to deserialize the corresponding LVDS serialized data (DnP, DnM).

## Do's and Don'ts (continued)

### 9.4.6 Failure to Provide Adequate Heat Removal

Use the appropriate thermal parameter listed in the table and an ambient, board, or case temperature to calculate device junction temperature. A suitable heat removal technique must be used to keep the device junction temperature below the maximum limit of 105°C.

## 10 Power Supply Recommendations

Figure 113 shows the suggested power-up sequencing and reset timing for the device.

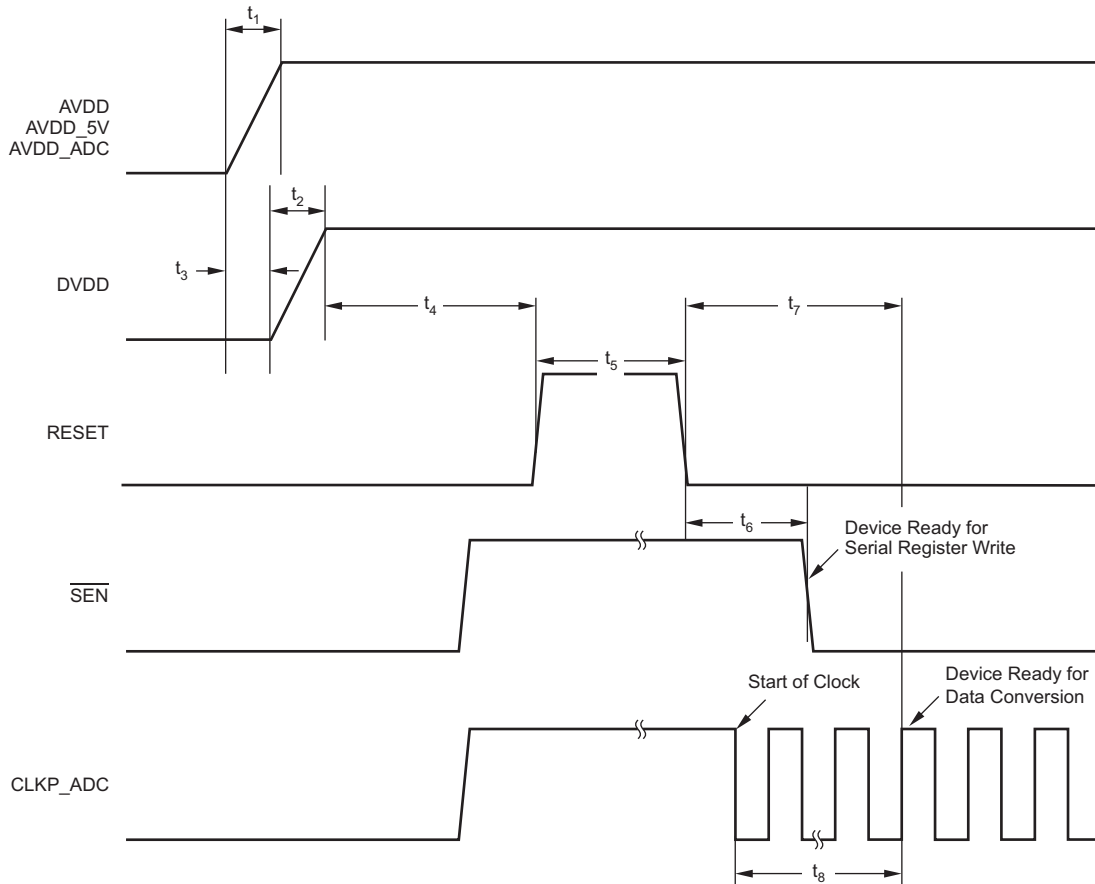

- $10\ \mu\text{s} < t_1 < 50\ \text{ms}$ ,  $10\ \mu\text{s} < t_2 < 50\ \text{ms}$ ,  $-10\ \text{ms} < t_3 < 10\ \text{ms}$ ,  $t_4 > 10\ \text{ms}$ ,  $t_5 > 100\ \text{ns}$ ,  $t_6 > 100\ \text{ns}$ ,  $t_7 > 10\ \text{ms}$ , and  $t_8 > 100\ \mu\text{s}$ . When the demodulator power DVDD\_LDO1 and DVDD\_LDO2 are supplied externally, it should be powered up 1ms after DVDD. LDOs for external DVDD\_LDO1 and DVDD\_LDO2 can be powered down if the demodulator is not used.
- The AVDDx and DVDD power-on sequence does not matter as long as  $-10\ \text{ms} < t_3 < 10\ \text{ms}$ . Similar considerations apply while shutting down the device.

**Figure 113. Recommended Power-Up Sequencing and Reset Timing with Internally Generated 1.4V Demod Supply**

### 10.1 Power/Performance Optimization

The AFE5809 device has options to adjust power consumption and meet different noise performances. This feature would be useful for portable systems operated by batteries when low power is more desired. Refer to characteristics information listed in the [Electrical Characteristics](#) as well as the [Typical Characteristics](#).

## 10.2 Power Management Priority

Power management plays a critical role to extend battery life and ensure long operation time. The AFE5809 device has fast and flexible power-down and power-up control which can maximize battery life. The AFE5809 can be powered down or up through external pins or internal registers. [Table 29](#) indicates the affected circuit blocks and priorities when the power management is invoked. The higher priority controls can overwrite the lower priority controls.

In the device, all the power-down controls are logically ORed to generate final power down for different blocks. The higher priority controls can cover the lower priority controls.

**Table 29. Power Management Priority**

	Name	Blocks	Priority
Pin	PDN_GLOBAL	All	High
Pin	PDN_VCA	LNA + VCAT+ PGA	Medium
Register	VCA_PARTIAL_PDN	LNA + VCAT+ PGA	Low
Register	VCA_COMPLETE_PDN	LNA + VCAT+ PGA	Medium
Pin	PDN_ADC	ADC	Medium
Register	ADC_PARTIAL_PDN	ADC	Low
Register	ADC_COMPLETE_PDN	ADC	Medium
Register	PDN_VCAT_PGA	VCAT + PGA	Lowest
Register	PDN_LNA	LNA	Lowest

## 10.3 Partial Power-Up and Power-Down Mode

The partial power-up and power-down mode is also called fast power-up and power-down mode. In this mode, most amplifiers in the signal path are powered down, while the internal reference circuits remain active as well as the LVDS clock circuit, that is, the LVDS circuit still generates its frame and bit clocks.

The partial power-down function allows the AFE5809 device to wake up from a low-power state quickly. This configuration ensures that the external capacitors are discharged slowly; thus, a minimum wake-up time is needed as long as the charges on those capacitors are restored. The VCA wake-up response is typically about 2  $\mu$ s or 1% of the power-down duration, whichever is larger. The longest wake-up time depends on the capacitors connected at INP and INM, because the wake-up time is the time required to recharge the capacitors to the desired operating voltages. 0.1  $\mu$ F at INP and 15 nF at INM can give a wake-up time of 2.5 ms. For larger capacitors, this time will be longer. The ADC wake-up time is about 1  $\mu$ s. Thus, the AFE5809 wake-up time is more dependent on the VCA wake-up time. This also assumes that the ADC clock has been running for at least 50  $\mu$ s before normal operating mode resumes. The power-down time is instantaneous, less than 1  $\mu$ s.

This fast wake-up response is desired for portable ultrasound applications in which the power saving is critical. The pulse repetition frequency of an ultrasound system could vary from 50 kHz to 500 Hz, while the imaging depth (that is, the active period for a receive path) varies from 10  $\mu$ s to hundreds of  $\mu$ s. The power saving can be significant when a system's PRF is low. In some cases, only the VCA would be powered down while the ADC keeps running normally to ensure minimal impact to FPGAs.

In the partial power-down mode, the AFE5809 device typically dissipates only 26 mW/ch, representing an 80% power reduction compared to the normal operating mode. This mode can be set using either pins (PDN\_VCA and PDN\_ADC) or register bits (VCA\_PARTIAL\_PDN and ADC\_PARTIAL\_PDN).

## 10.4 Complete Power-Down Mode

To achieve the lowest power dissipation of 0.7 mW/CH, the AFE5809 device can be placed into a complete power-down mode. This mode is controlled through the registers ADC\_COMPLETE\_PDN, VCA\_COMPLETE\_PDN, or PDN\_GLOBAL pin. In the complete power-down mode, all circuits including reference circuits within the AFE5809 device are powered down, and the capacitors connected to the AFE5809 device are discharged. The wake-up time depends on the time needed to recharge these capacitors. The wake-up time depends on the time that the AFE5809 device spends in shutdown mode. 0.1  $\mu$ F at INP and 15 nF at INM can give a wake-up time close to 2.5 ms.

## Complete Power-Down Mode (continued)

---

### NOTE

When the complete power-down mode is enabled, the digital demodulator may lose register settings. Therefore, it is required to reconfigure the demodulator registers, filter coefficient memory, and profile memory after exiting the complete power-down mode.

---

## 10.5 Power Saving in CW Mode

Usually, only half the number of channels in a system are active in the CW mode. Thus, the individual channel control through ADC\_PDN\_CH <7:0> and VCA\_PDN\_CH <7:0> can power down unused channels and save power consumption greatly. Under the default register setting in CW mode, the voltage controlled attenuator, PGA, and ADC are still active. During the debug phase, both the PW and CW paths can run simultaneously. In real operation, these blocks must be powered down manually.

## 11 Layout

### 11.1 Layout Guidelines

Proper grounding and bypassing, short lead length, and the use of ground and power-supply planes are particularly important for high-frequency designs. Achieving optimum performance with a high-performance device such as the AFE5809 requires careful attention to the PCB layout to minimize the effects of board parasitics and optimize component placement. A multilayer PCB usually ensures best results and allows convenient component placement. To maintain proper LVDS timing, all LVDS traces should follow a controlled impedance design. In addition, all LVDS trace lengths should be equal and symmetrical; TI recommends to keep trace length variations less than 150 mil (0.150 inch or 3.81 mm).

---

### NOTE

To avoid noise coupling through supply pins, TI recommends keeping sensitive input net classes, such as INM, INP, ACT pins, away from AVDD 3.3 V, AVDD\_5V, DVDD, AVDD\_ADC, DVDD\_LDO1/2 nets or planes. For example, vias connected to these pins should NOT be routed across any supply plane. That is to avoid power planes under INM, INP, and ACT pins.

---

In addition, appropriate delay matching should be considered for the CW clock path, especially in systems with high channel count. For example, if clock delay is half of the 16x clock period, a phase error of 22.5° could exist. Thus, the timing delay difference among channels contributes to the beamformer accuracy.

Additional details on BGA PCB layout techniques can be found in the TI application report *MicroStar BGA Packaging Reference Guide* (SSYZ015), which can be downloaded from [www.ti.com](http://www.ti.com).

## 11.2 Layout Example

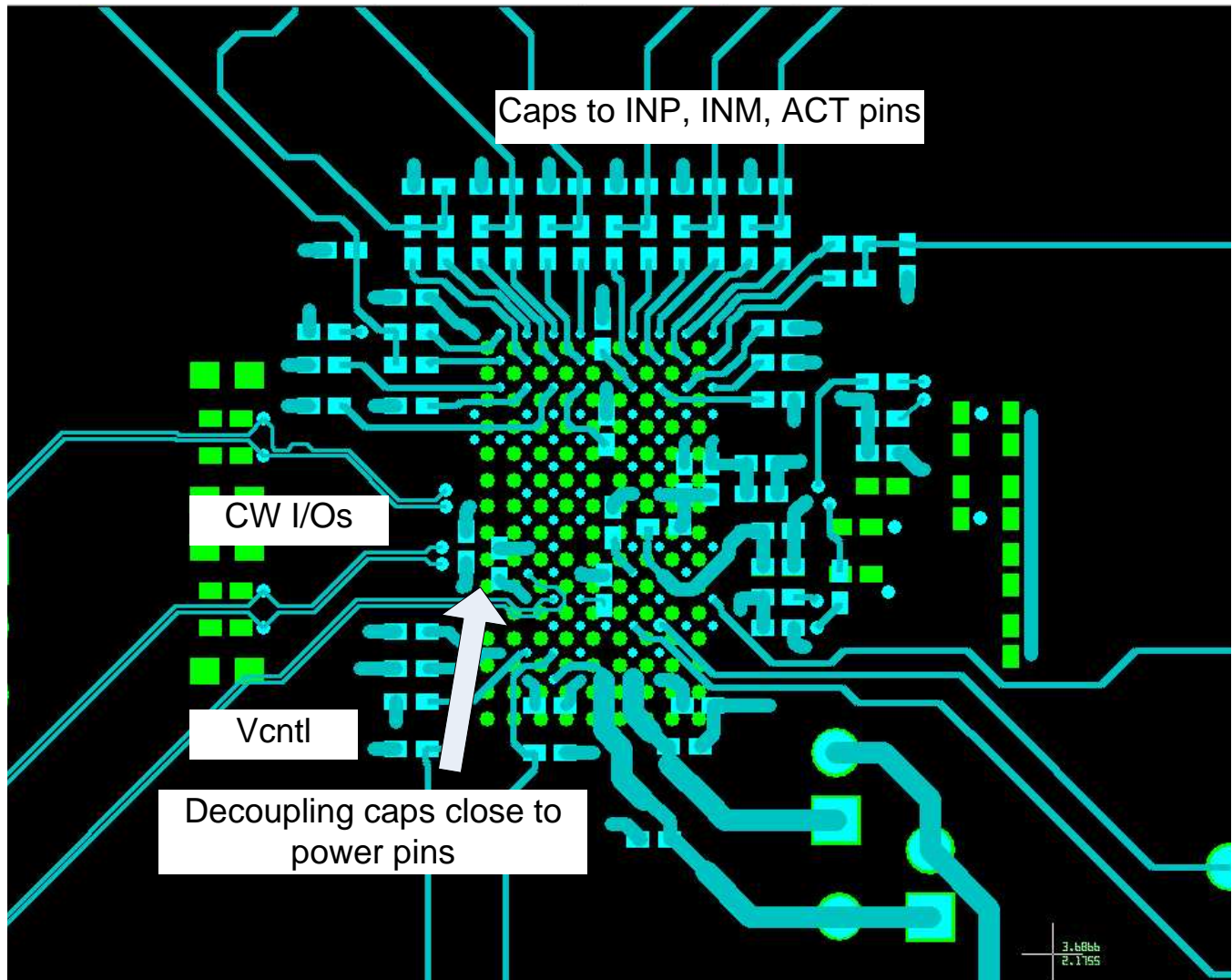

Figure 114. Layout Example

Layout Example (continued)

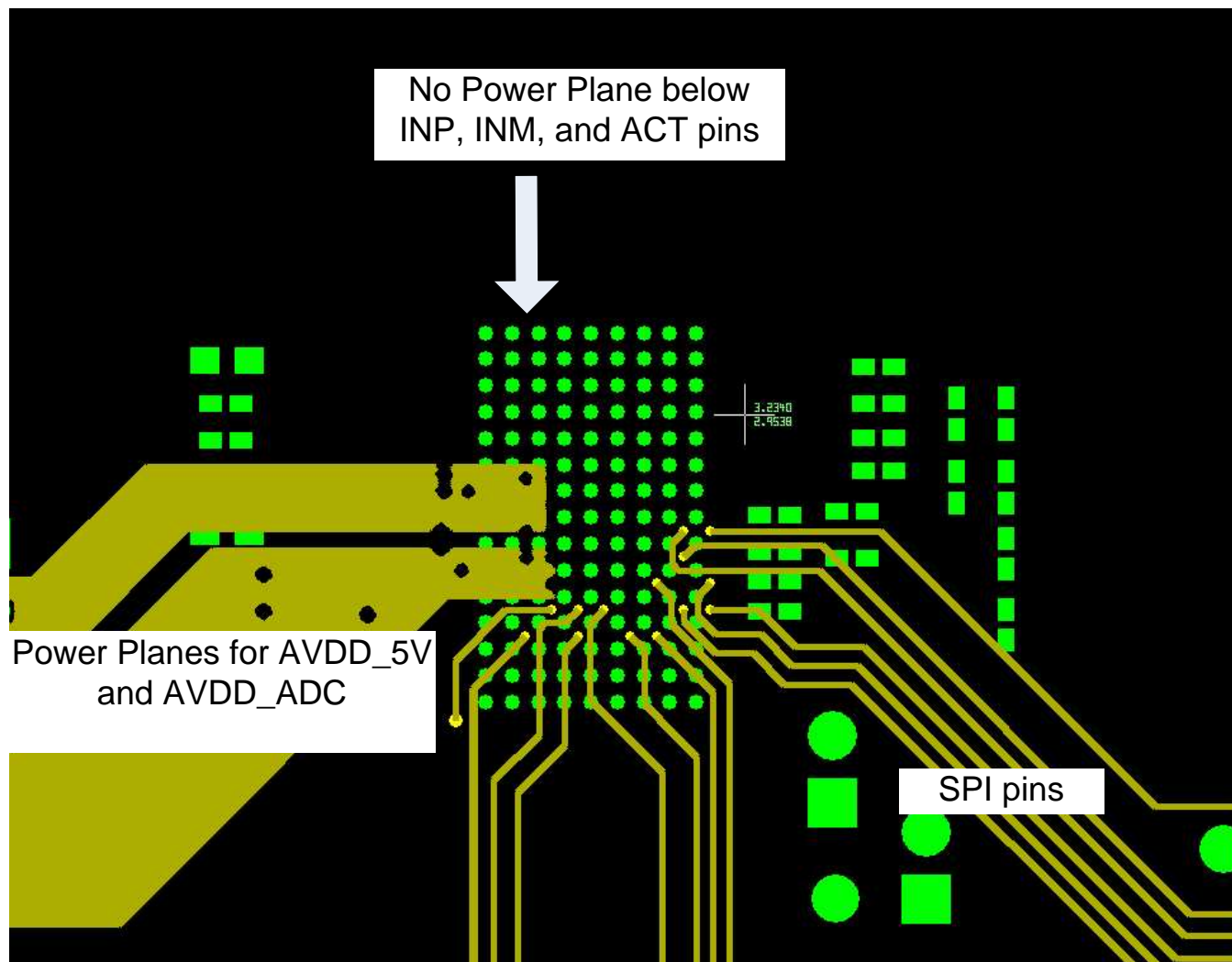

Figure 115. Layout Example

Layout Example (continued)

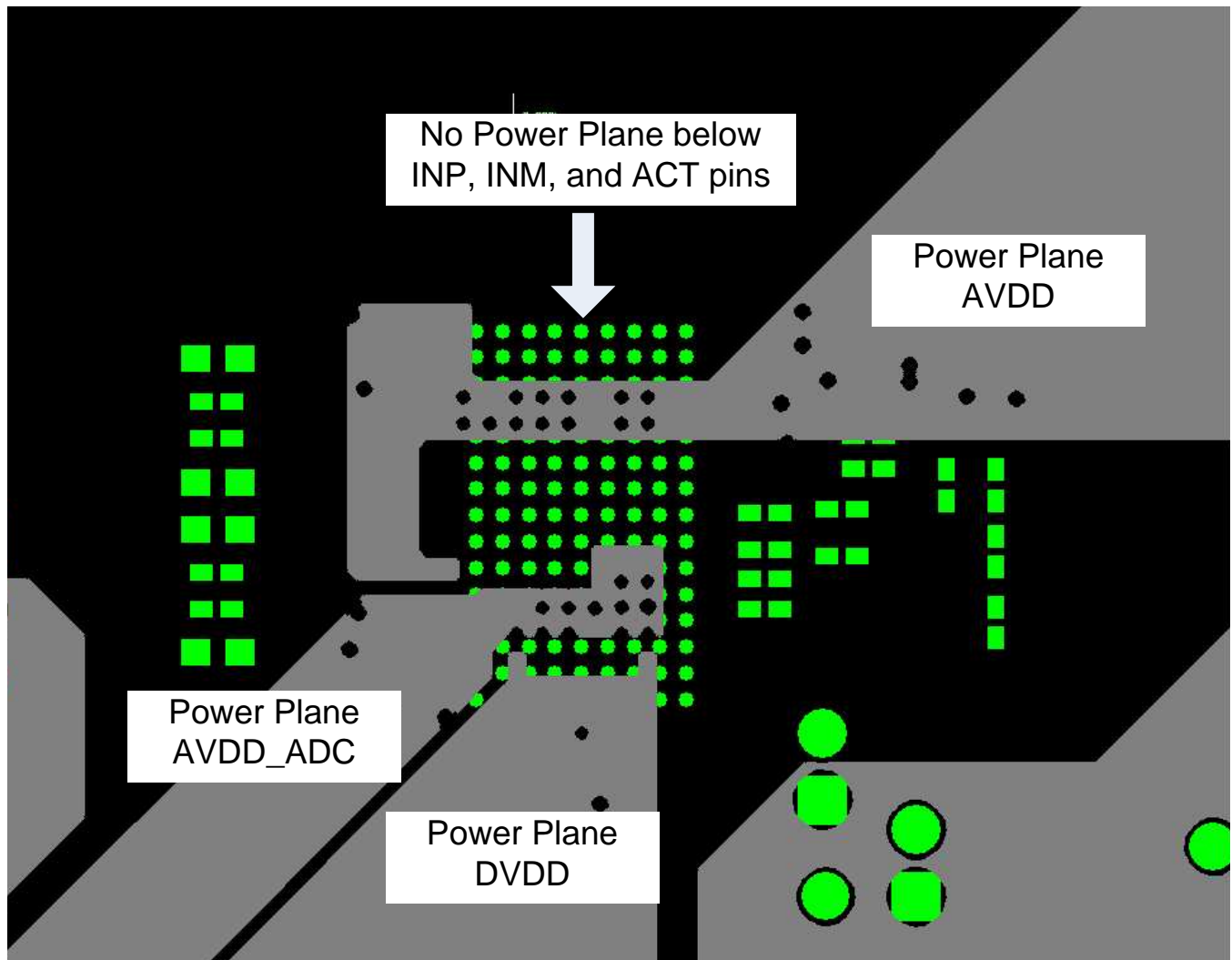

Figure 116. Layout Example

Layout Example (continued)

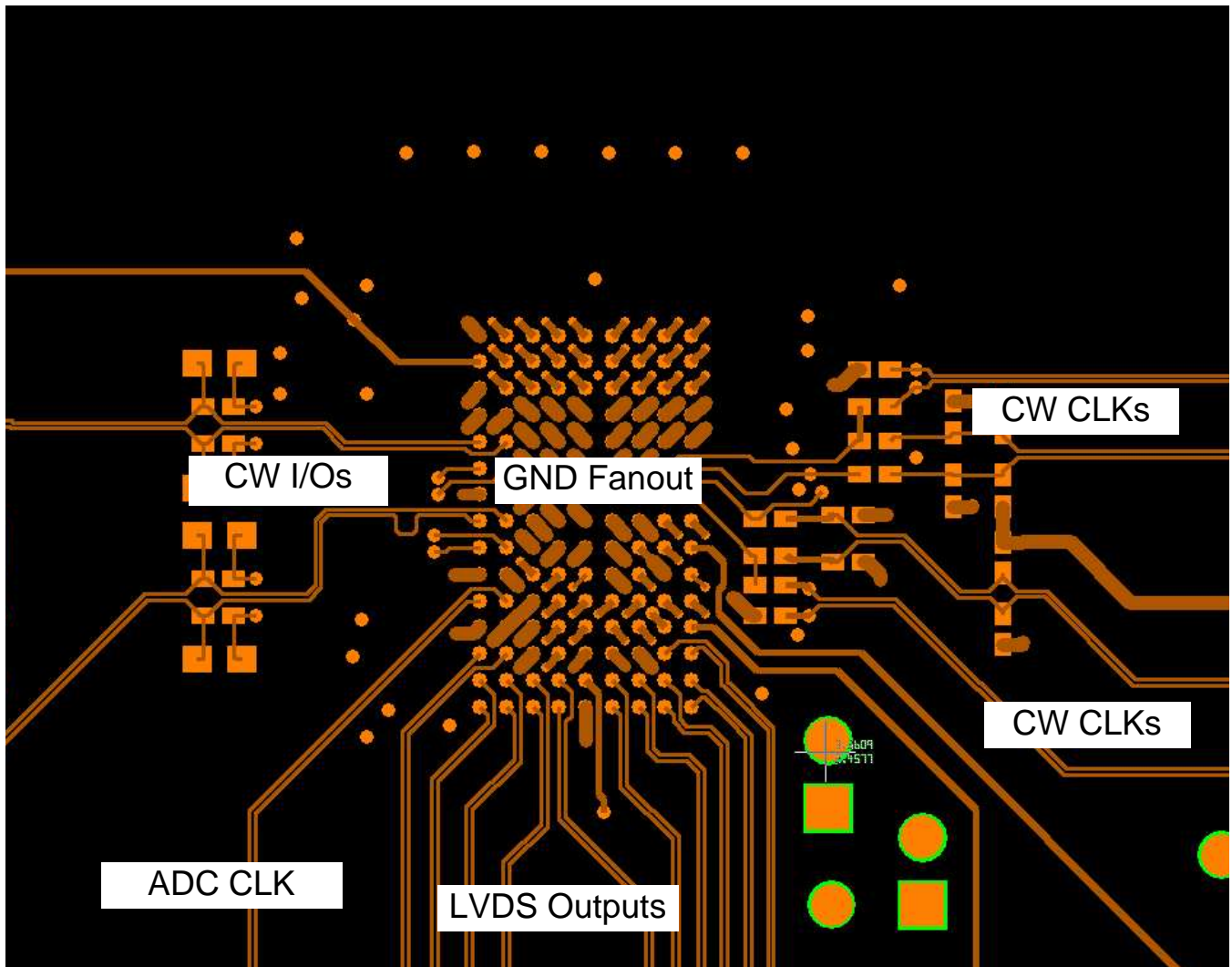

Figure 117. Layout Example

## 12 Device and Documentation Support

### 12.1 Device Support

#### 12.1.1 Development Support

For the Power Stage Designer see [www.ti.com/filterdesigner](http://www.ti.com/filterdesigner)

### 12.2 Documentation Support

#### 12.2.1 Related Documentation

For related documentation see the following:

- *MicroStar BGA Packaging Reference Guide*, [SSYZ015](#)
- *Clocking High-Speed Data Converters*, [SLYT075](#)

### 12.3 Community Resources

The following links connect to TI community resources. Linked contents are provided "AS IS" by the respective contributors. They do not constitute TI specifications and do not necessarily reflect TI's views; see TI's [Terms of Use](#).

**TI E2E™ Online Community** *TI's Engineer-to-Engineer (E2E) Community*. Created to foster collaboration among engineers. At [e2e.ti.com](http://e2e.ti.com), you can ask questions, share knowledge, explore ideas and help solve problems with fellow engineers.

**Design Support** *TI's Design Support* Quickly find helpful E2E forums along with design support tools and contact information for technical support.

### 12.4 Trademarks

E2E is a trademark of Texas Instruments.  
All other trademarks are the property of their respective owners.

### 12.5 Electrostatic Discharge Caution



These devices have limited built-in ESD protection. The leads should be shorted together or the device placed in conductive foam during storage or handling to prevent electrostatic damage to the MOS gates.

### 12.6 Glossary

[SLYZ022](#) — *TI Glossary*.

This glossary lists and explains terms, acronyms, and definitions.

## 13 Mechanical, Packaging, and Orderable Information

The following pages include mechanical, packaging, and orderable information. This information is the most current data available for the designated devices. This data is subject to change without notice and revision of this document. For browser-based versions of this data sheet, refer to the left-hand navigation.

**PACKAGING INFORMATION**

Orderable Device	Status (1)	Package Type	Package Drawing	Pins	Package Qty	Eco Plan (2)	Lead/Ball Finish (6)	MSL Peak Temp (3)	Op Temp (°C)	Device Marking (4/5)	Samples
AFE5809ZCF	ACTIVE	NFBGA	ZCF	135	160	Green (RoHS & no Sb/Br)	SNAGCU	Level-3-260C-168 HR	0 to 85	AFE5809	Samples

(1) The marketing status values are defined as follows:

**ACTIVE:** Product device recommended for new designs.

**LIFEBUY:** TI has announced that the device will be discontinued, and a lifetime-buy period is in effect.

**NRND:** Not recommended for new designs. Device is in production to support existing customers, but TI does not recommend using this part in a new design.

**PREVIEW:** Device has been announced but is not in production. Samples may or may not be available.

**OBSELETE:** TI has discontinued the production of the device.

(2) Eco Plan - The planned eco-friendly classification: Pb-Free (RoHS), Pb-Free (RoHS Exempt), or Green (RoHS & no Sb/Br) - please check <http://www.ti.com/productcontent> for the latest availability information and additional product content details.

**TBD:** The Pb-Free/Green conversion plan has not been defined.

**Pb-Free (RoHS):** TI's terms "Lead-Free" or "Pb-Free" mean semiconductor products that are compatible with the current RoHS requirements for all 6 substances, including the requirement that lead not exceed 0.1% by weight in homogeneous materials. Where designed to be soldered at high temperatures, TI Pb-Free products are suitable for use in specified lead-free processes.

**Pb-Free (RoHS Exempt):** This component has a RoHS exemption for either 1) lead-based flip-chip solder bumps used between the die and package, or 2) lead-based die adhesive used between the die and leadframe. The component is otherwise considered Pb-Free (RoHS compatible) as defined above.

**Green (RoHS & no Sb/Br):** TI defines "Green" to mean Pb-Free (RoHS compatible), and free of Bromine (Br) and Antimony (Sb) based flame retardants (Br or Sb do not exceed 0.1% by weight in homogeneous material)

(3) MSL, Peak Temp. - The Moisture Sensitivity Level rating according to the JEDEC industry standard classifications, and peak solder temperature.

(4) There may be additional marking, which relates to the logo, the lot trace code information, or the environmental category on the device.

(5) Multiple Device Markings will be inside parentheses. Only one Device Marking contained in parentheses and separated by a "~" will appear on a device. If a line is indented then it is a continuation of the previous line and the two combined represent the entire Device Marking for that device.

(6) Lead/Ball Finish - Orderable Devices may have multiple material finish options. Finish options are separated by a vertical ruled line. Lead/Ball Finish values may wrap to two lines if the finish value exceeds the maximum column width.

**Important Information and Disclaimer:** The information provided on this page represents TI's knowledge and belief as of the date that it is provided. TI bases its knowledge and belief on information provided by third parties, and makes no representation or warranty as to the accuracy of such information. Efforts are underway to better integrate information from third parties. TI has taken and continues to take reasonable steps to provide representative and accurate information but may not have conducted destructive testing or chemical analysis on incoming materials and chemicals. TI and TI suppliers consider certain information to be proprietary, and thus CAS numbers and other limited information may not be available for release.

In no event shall TI's liability arising out of such information exceed the total purchase price of the TI part(s) at issue in this document sold by TI to Customer on an annual basis.





## IMPORTANT NOTICE AND DISCLAIMER

TI PROVIDES TECHNICAL AND RELIABILITY DATA (INCLUDING DATASHEETS), DESIGN RESOURCES (INCLUDING REFERENCE DESIGNS), APPLICATION OR OTHER DESIGN ADVICE, WEB TOOLS, SAFETY INFORMATION, AND OTHER RESOURCES "AS IS" AND WITH ALL FAULTS, AND DISCLAIMS ALL WARRANTIES, EXPRESS AND IMPLIED, INCLUDING WITHOUT LIMITATION ANY IMPLIED WARRANTIES OF MERCHANTABILITY, FITNESS FOR A PARTICULAR PURPOSE OR NON-INFRINGEMENT OF THIRD PARTY INTELLECTUAL PROPERTY RIGHTS.

These resources are intended for skilled developers designing with TI products. You are solely responsible for (1) selecting the appropriate TI products for your application, (2) designing, validating and testing your application, and (3) ensuring your application meets applicable standards, and any other safety, security, or other requirements. These resources are subject to change without notice. TI grants you permission to use these resources only for development of an application that uses the TI products described in the resource. Other reproduction and display of these resources is prohibited. No license is granted to any other TI intellectual property right or to any third party intellectual property right. TI disclaims responsibility for, and you will fully indemnify TI and its representatives against, any claims, damages, costs, losses, and liabilities arising out of your use of these resources.

TI's products are provided subject to TI's Terms of Sale ([www.ti.com/legal/termsofsale.html](http://www.ti.com/legal/termsofsale.html)) or other applicable terms available either on [ti.com](http://ti.com) or provided in conjunction with such TI products. TI's provision of these resources does not expand or otherwise alter TI's applicable warranties or warranty disclaimers for TI products.

Mailing Address: Texas Instruments, Post Office Box 655303, Dallas, Texas 75265  
Copyright © 2019, Texas Instruments Incorporated

## Looking for pricing, stock, or lifecycle information?

Click below to explore more details on WIN SOURCE:

 [View AFE5809ZCF](#) on WIN SOURCE

 [Texas Instruments](#) Information

## Optimize Your Supply Chain with WIN SOURCE Solutions

-  Global Sourcing Solution
-  Obsolete Management
-  Cost Control Management
-  Shortage Management
-  Alternative Solution
-  Excess Inventory Management