

AFCT-5971LZ/ALZ

Single Mode Laser Small Form Factor
Fast Ethernet Transceivers



Data Sheet



Description

The AFCT-5971LZ/ALZ are high performance, cost effective modules for serial optical data communications applications specified for a signal rate of 125 Mbd. They are designed for fast ethernet applications and are also compatible with the EFM baseline 100-BASE-LX10 standard over dual single mode fiber.

All modules are designed for single mode fiber and operate at a nominal wavelength of 1300 nm. They incorporate high performance, reliable, long wavelength optical devices and proven circuit technology to give long life and consistent service.

The transmitter section of the AFCT-5971LZ/ALZ incorporates a 1300 nm Fabry Perot (FP) laser. The transmitter has full IEC 825 and CDRH Class 1 eye safety.

The receiver section uses an MOVPE grown planar PIN photodetector for low dark current and excellent responsivity.

A pseudo-ECL compatible logic interface simplifies interface to external circuitry.

These transceivers are supplied in the new industry standard 2 x 5 DIP style package with the LC fiber connector interface and is footprint compatible with SFF Multi Source Agreement (MSA).

Features

- Multisourced 2 x 5 package style with LC receptacle
- Single +3.3 V power supply
- Temperature range:
AFCT-5971LZ: 0 °C to +70 °C
AFCT-5971ALZ: -40°C to +85°C
- Wave solder and aqueous wash process compatible
- Manufactured in an ISO9002 certified facility
- Fully Class 1 CDRH/IEC 825 compliant
- IEEE 802.3ah Standard Compliant
- RoHS Compliant
- LVPECL compatible signal detect output
- Designed for EFM (Ethernet in the First Mile) baseline 100-BASE-LX10 performance over dual single mode fiber

Applications

- Ethernet in the First Mile
- Fast Ethernet

Functional Description

Receiver Section

Design

The receiver section for the AFCT-5971LZ/ALZ contains an InGaAs/InP photo detector and a preamplifier mounted in an optical subassembly. This optical subassembly is coupled to a postamp/decision circuit on a circuit board. The design of the optical assembly is such that it provides better than 14 dB Optical Return Loss (ORL).

The postamplifier is ac coupled to the preamplifier as illustrated in Figure 1. The coupling capacitors are large enough to pass the EFM test pattern at 125 MBd without significant distortion or performance penalty.

Figure 1 also shows a filter function which limits the bandwidth of the preamp output signal. The filter is designed to bandlimit the preamp output noise and thus improve the receiver sensitivity.

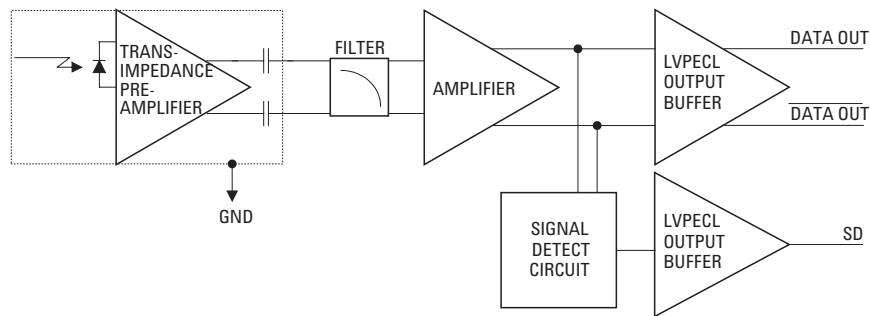

Figure 1. Receiver Block Diagram

Functional Description

Transmitter Section

Design

A schematic diagram for the transmitter is shown in Figure 2. The AFCT-5971LZ/ALZ incorporates an FP laser as its optical source. All part numbers have been designed to be compliant with IEC 825 eye safety requirements under any single fault condition and CDRH under normal operating conditions. The optical output is controlled by a custom IC that detects the laser output via the monitor photodiode. This IC provides both dc and ac current drive to the laser to ensure correct modulation, eye diagram and extinction ratio over temperature, supply voltage and operating life.

These components will reduce the sensitivity of the receiver as the signal bit rate is increased above 155 Mb/s.

Noise Immunity

The receiver includes internal circuit components to filter power supply noise. However under some conditions of EMI and power supply noise, external power supply filtering may be necessary (see Application Section).

The Signal Detect Circuit

The signal detect circuit works by sensing the level of the received signal and comparing this level to a reference. The SD output is low voltage PECL.

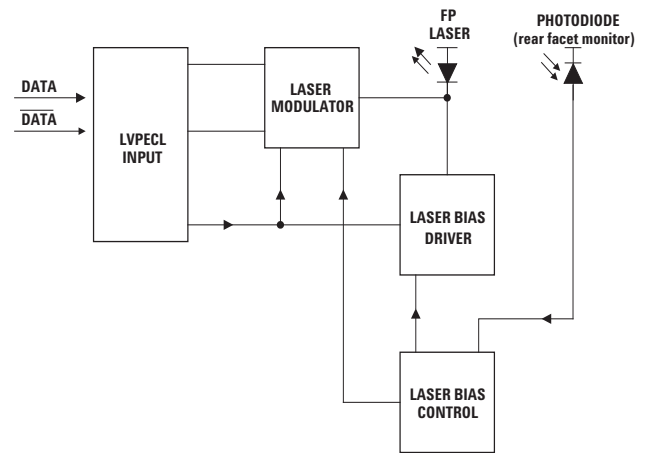

Figure 2. Simplified Transmitter Schematic

Package

The overall package concept for these devices consists of the following basic elements; two optical subassemblies, a electrical subassembly and the housing as illustrated in the block diagram in Figure 3.

The package outline drawing and pin out are shown in Figures 4 and 5. The details of this package outline and pin out are compliant with the multisource definition of the 2 x 5 DIP. The low profile of the Avago Technologies transceiver design complies with the maximum height allowed for the LC connector over the entire length of the package.

The electrical subassembly consists of high volume multilayer printed circuit board on which the IC and various surface-mounted passive circuit elements are attached.

The optical subassemblies are attached to the electrical subassembly. These two units are then fitted within the outer housing of the transceiver. The housing is then encased with a metal EMI protective shield.

The electrical subassembly carries the signal pins that exit from the bottom of the transceiver. The solder posts are designed to provide the mechanical strength required to withstand the loads imposed on the transceiver by mating with the LC connected fiber cables. Although they are not connected electrically to the transceiver, it is recommended to connect them to chassis ground.

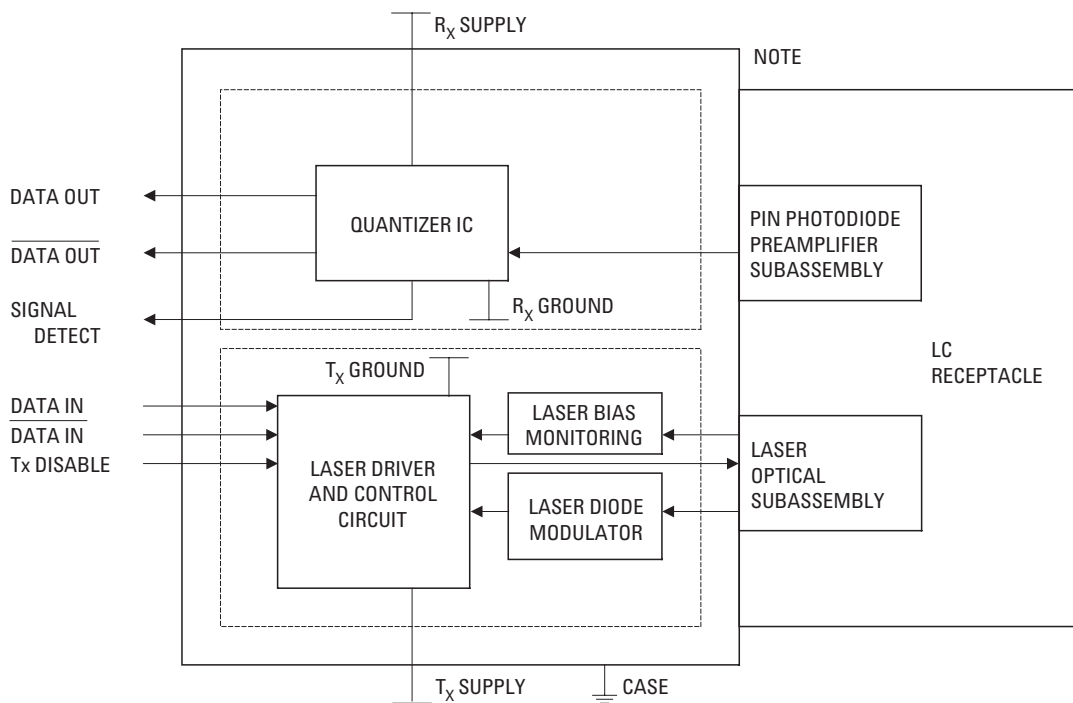

NOTE: NOSE CLIP PROVIDES CONNECTION TO CHASSIS GROUND FOR BOTH EMI AND THERMAL DISSIPATION.

Figure 3. Block Diagram

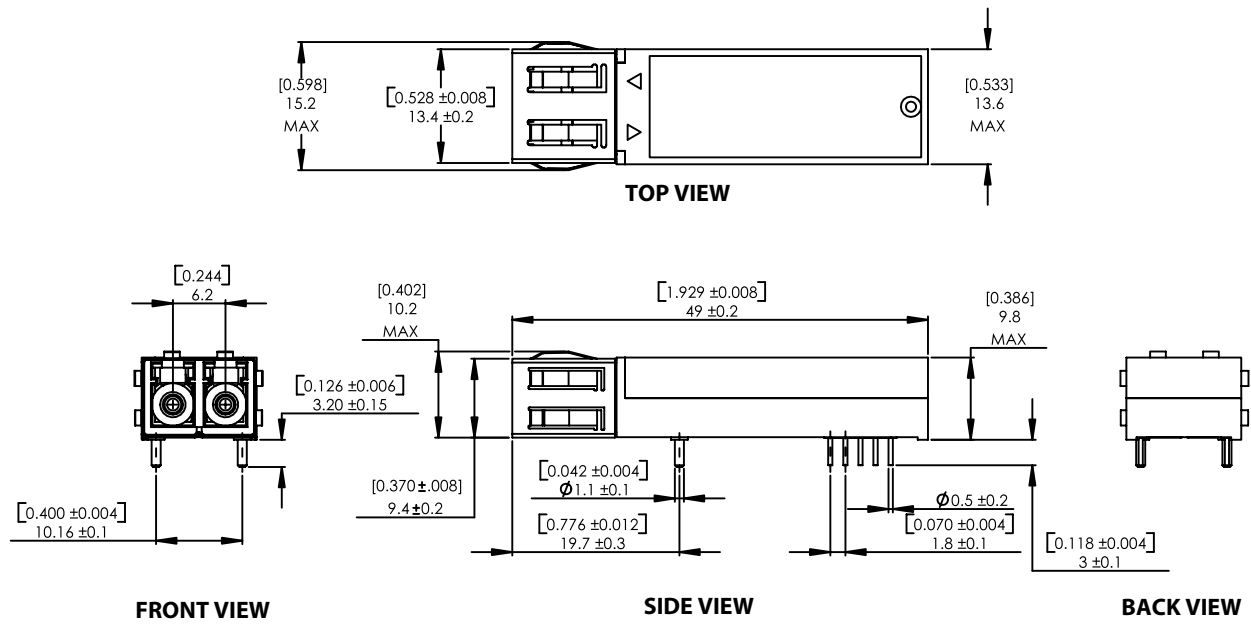

G MODULE - NO EMI SHIELD

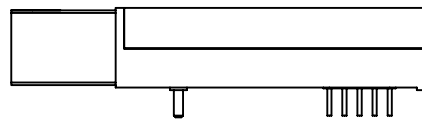

SIDE VIEW

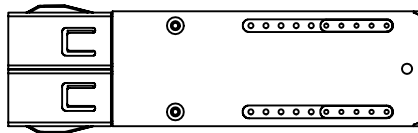

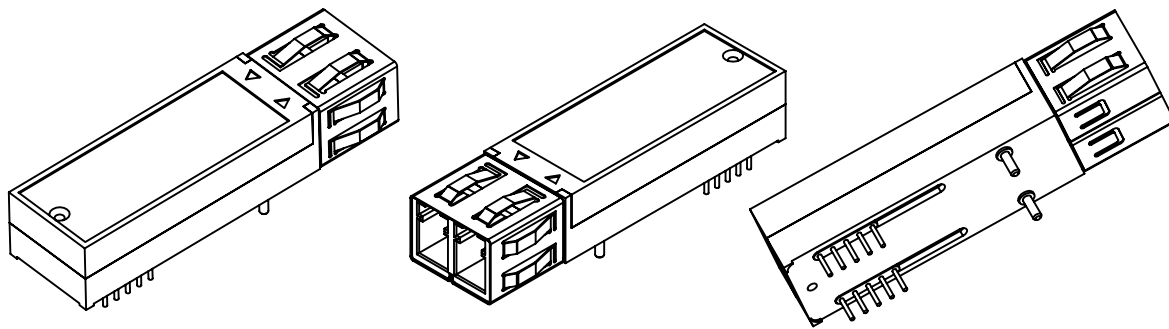

BOTTOM VIEW



DIMENSIONS IN MILLIMETERS (INCHES)
DIMENSIONS SHOWN ARE NOMINAL. ALL DIMENSIONS MEET THE MAXIMUM PACKAGE OUTLINE DRAWING IN THE SFF MSA.

Figure 4. AFCT-5971LZ/ALZ Package Outline Drawing

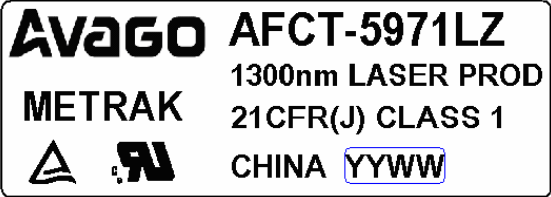
Label Instructions:

| | |
|---|--|
|  |  |
| <p>Product Label Format</p> | <p>Barcode Label Format</p> |

a) Product Label:

- CHINA is the Country of Manufacturing.
- YYWW is Year and Workweek.
-  is TUV Symbol.

b) Barcode Label:

- ACDDEEFXXXX
 - AC is AFCT product prefix
 - DDEE is Year and Workweek of barcode label
 - F is SFF product identifier
 - XXXX is 4 alphanumeric no in running sequence.
- Marking is done by Labeling on the module. Label Location Refer to **Special Assembly Notes**.

Special Assembly Notes:

- a) The label is attached on top of the metal housing.
- b) External nose shield is included.

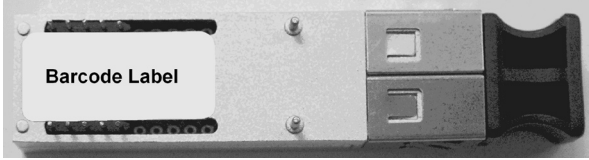
| | |
|---|--|
|  |  |
| <p>Top View & Label Location</p> | <p>Bottom View & Label Location</p> |

Connection Diagram

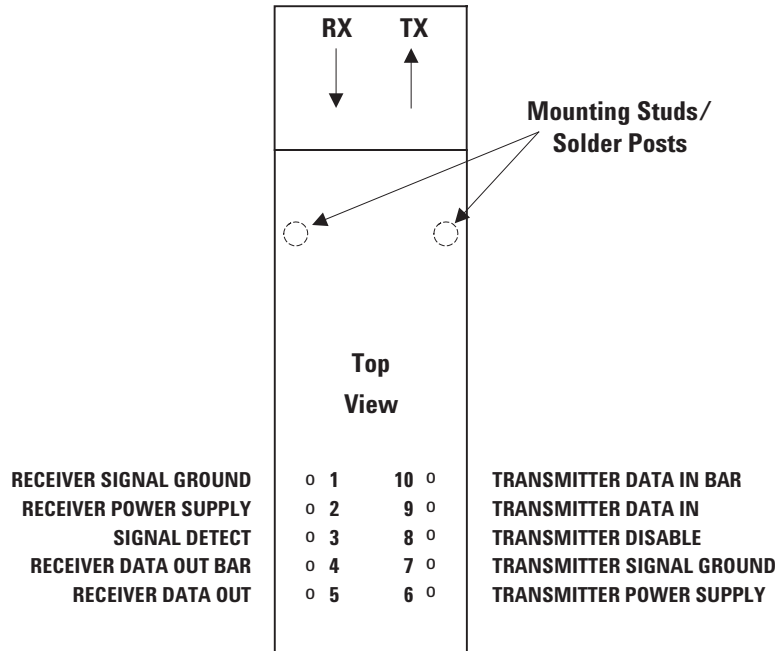

Figure 5. Pin Out Diagram (Top View)

Pin Descriptions:

Pin 1 Receiver Signal Ground $V_{EE\ RX}$:

Directly connect this pin to the receiver ground plane.

Pin 2 Receiver Power Supply $V_{CC\ RX}$:

Provide +3.3 V dc via the recommended receiver power supply filter circuit. Locate the power supply filter circuit as close as possible to the $V_{CC\ RX}$ pin. Note: the filter circuit should not cause V_{CC} to drop below minimum specification.

Pin 3 Signal Detect SD:

Normal optical input levels to the receiver result in a logic "1" output.

Low optical input levels to the receiver result in a logic "0" output.

This Signal Detect output can be used to drive a LVPECL input on an upstream circuit, such as Signal Detect input or Loss of Signal-bar.

Pin 4 Receiver Data Out Bar RD-:

No internal terminations are provided. See recommended circuit schematic.

Pin 5 Receiver Data Out RD+:

No internal terminations are provided. See recommended circuit schematic.

Pin 6 Transmitter Power Supply

$V_{CC\ TX}$:

Provide +3.3 V dc via the recommended transmitter power supply filter circuit. Locate the power supply filter circuit as close as possible to the $V_{CC\ TX}$ pin.

Pin 7 Transmitter Signal Ground

$V_{EE\ TX}$:

Directly connect these pins to the transmitter signal ground plane.

Pin 8 Transmitter Disable T_{DIS} :

Optional feature, connect this pin to +3.3 V TTL logic high "1" to disable module. To enable module connect to TTL logic low "0".

Pin 9 Transmitter Data In TD+:

No internal terminations are provided. See recommended circuit schematic.

Pin 10 Transmitter Data In Bar TD-:

No internal terminations are provided. See recommended circuit schematic.

Mounting Studs/Solder Posts

The two mounting studs are provided for transceiver mechanical attachment to the circuit board. It is recommended that the holes in the circuit board be connected to chassis ground.

Application Information

The Applications Engineering Group at Avago Technologies is available to assist you with technical understanding and design trade-offs associated with these transceivers. You can contact them through your Avago sales representative.

The following information is provided to answer some of the most common questions about the use of the parts.

Optical Power Budget and Link Penalties

The worst-case Optical Power Budget (OPB) in dB for a fiber-optic link is determined by the difference between the minimum transmitter output optical power (dBm avg) and the lowest receiver sensitivity (dBm avg). This OPB provides the necessary optical signal range to establish a working fiber-optic link. The OPB is allocated for the fiber-optic cable length and the corresponding link penalties. For proper link performance, all penalties that affect the link performance must be accounted for within the link optical power budget.

Electrical and Mechanical Interface

Recommended Circuit

Figures 6a and 6b show recommended dc and ac coupled circuits for deploying the Avago Technologies transceivers in +3.3 V systems.

Data Line Interconnections

Avago Technologies' AFCT-5971LZ/ALZ fiber-optic transceivers are designed to couple to +3.3 V PECL signals. The transmitter driver circuit regulates the output optical power. The regulated light output will maintain a constant output optical power provided the data pattern is reasonably balanced in duty cycle. If the data duty cycle has long, continuous state times (low or high data duty cycle), then the output optical power will gradually change its average output optical power level to its preset value.

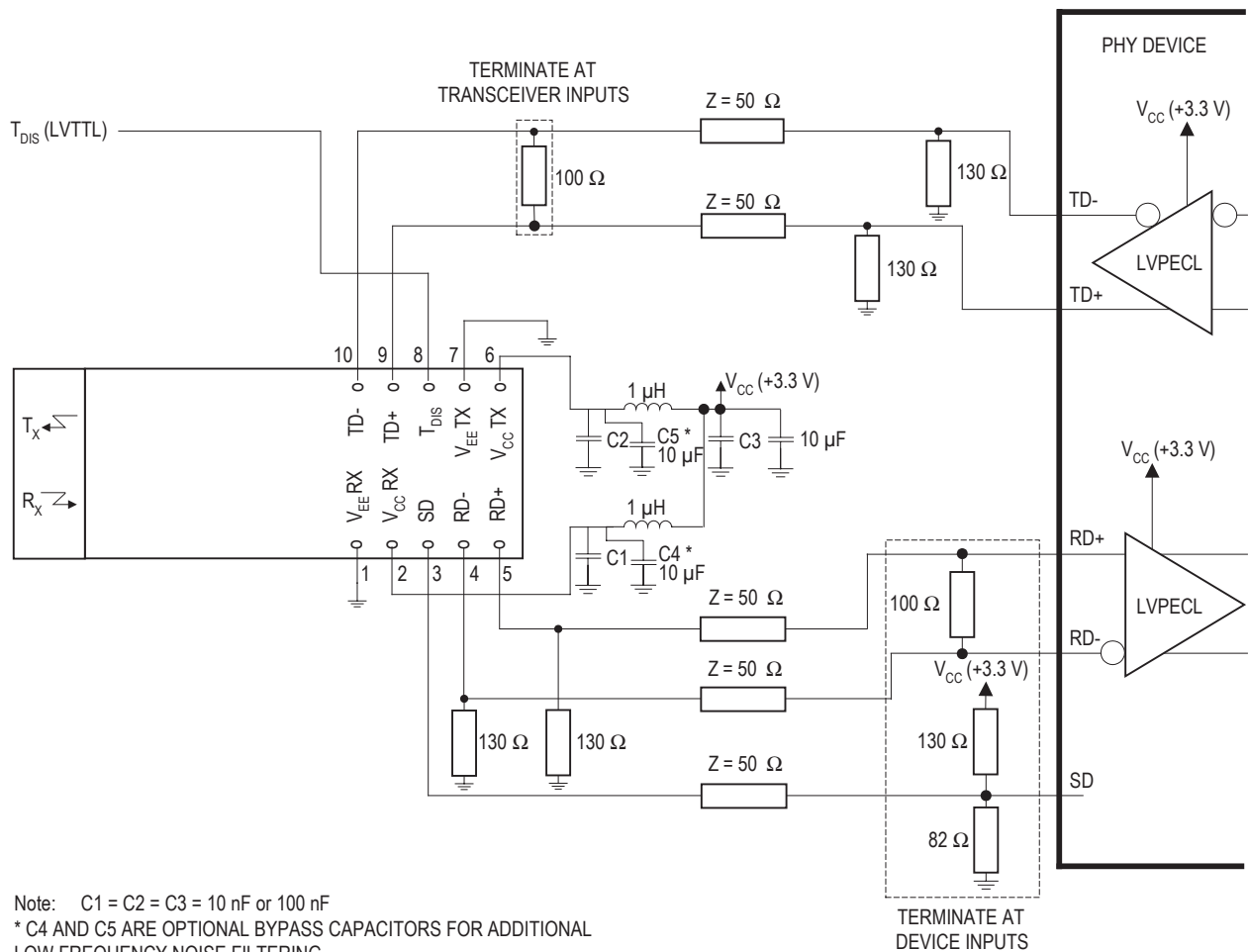

Figure 6a. Recommended dc Coupled Interface Circuit

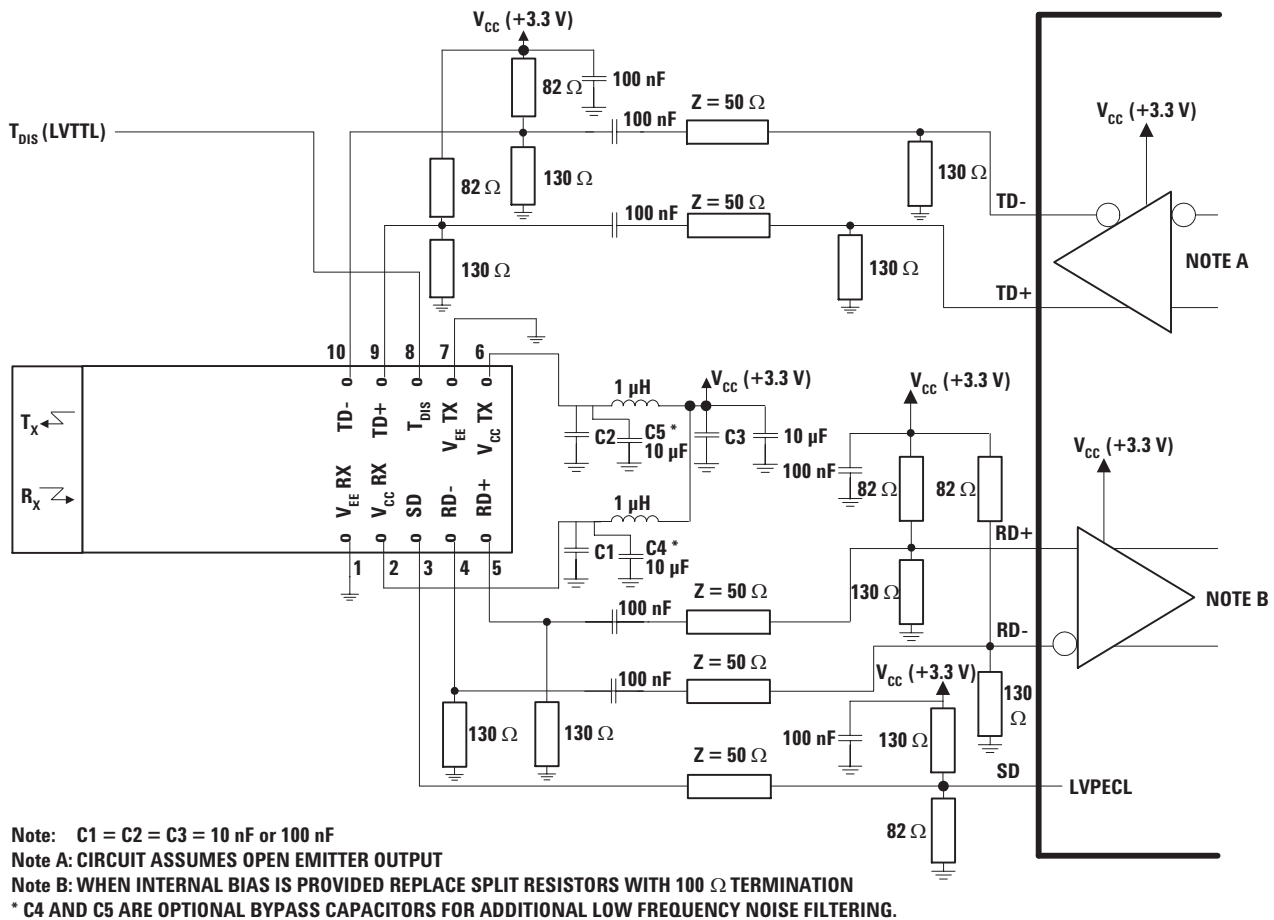

Figure 6b. Recommended ac Coupled Interface Circuit

The AFCT-5971LZ/ALZ have a transmit disable function which is a single-ended +3.3 V TTL input which is dc-coupled to pin 8.

As for the receiver section, it is internally ac-coupled between the preamplifier and the postamplifier stages. The actual Data and Data-bar outputs of the postamplifier are dc-coupled to their respective output pins (pins 4, 5). The two data outputs of the receiver should be terminated with identical load circuits.

Signal Detect is a single-ended, +3.3 V PECL compatible output signal that is dc-coupled to pin 3 of the module. Signal Detect should not be ac-coupled externally to the follow-on circuits because of its infrequent state changes.

Power Supply Filtering and Ground Planes

It is important to exercise care in circuit board layout to achieve optimum performance from these transceivers. Figures 6a and 6b show the power supply circuit which complies with the small form factor multisource agreement. It is further recommended that a continu-

ous ground plane be provided in the circuit board directly under the transceiver to provide a low inductance ground for signal return current. This recommendation is in keeping with good high frequency board layout practices.

Package footprint and front panel considerations

The Avago Technologies transceivers comply with the circuit board “Common Transceiver Footprint” hole pattern defined in the current multisource agreement which defined the 2 x 5 package style. This drawing is reproduced in Figure 7 with the addition of ANSI Y14.5M compliant dimensioning to be used as a guide in the mechanical layout of your circuit board. Figure 8 shows the front panel dimensions associated with such a layout.

Eye Safety Circuit

For an optical transmitter device to be eye-safe in the event of a single fault failure, the transmitter must either maintain eye-safe operation or be disabled.

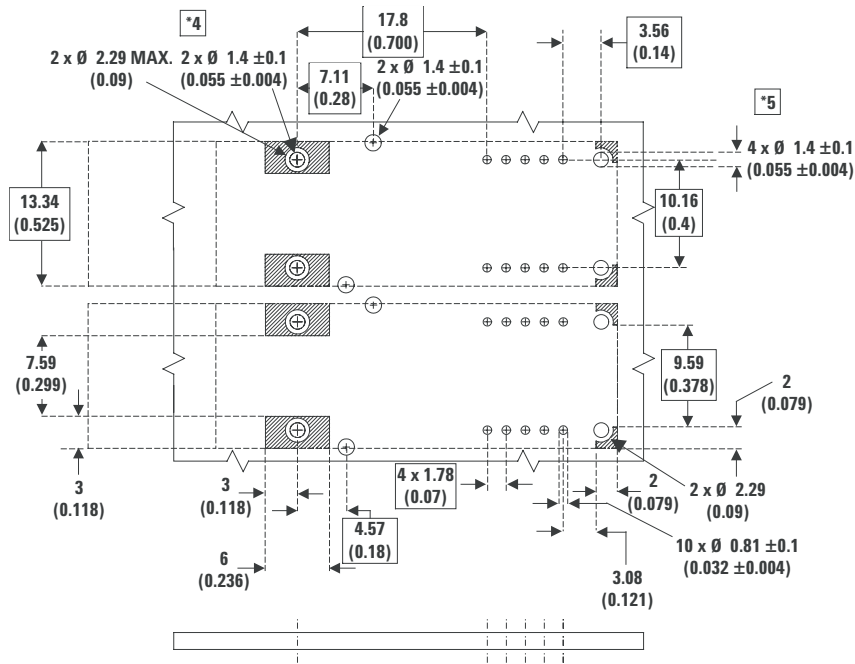

DIMENSIONS IN MILLIMETERS (INCHES)

Figure 7. Recommended Board Layout Hole Pattern

NOTES:

1. THIS FIGURE DESCRIBES MSA RECOMMENDED CIRCUIT BOARD LAYOUT FOR THE SFF TRANSCEIVER.
 2. THE HATCHED AREAS ARE KEEP-OUT AREAS RESERVED FOR HOUSING STANDOFFS. NO METAL TRACES OR GROUND CONNECTION IN KEEP-OUT AREAS.
 3. 2 x 5 TRANSCEIVER MODULE REQUIRES 16 PCB HOLES (10 I/O PINS, 2 SOLDER POSTS AND 4 OPTIONAL PACKAGE GROUNDING TABS). PACKAGE GROUNDING TABS SHOULD BE CONNECTED TO SIGNAL GROUND.
- *4. THE MOUNTING STUDS SHOULD BE SOLDERED TO CHASSIS GROUND FOR MECHANICAL INTEGRITY AND TO ENSURE FOOTPRINT COMPATIBILITY WITH OTHER SFF TRANSCEIVERS.
- *5. HOLES FOR OPTIONAL HOUSING LEADS MUST BE TIED TO SIGNAL GROUND.

The AFCT-5971LZ/ALZ is intrinsically eye safe and does not require shut down circuitry.

Signal Detect

The Signal Detect circuit provides a deasserted output signal when the optical link is broken (or when the remote transmitter is OFF). The Signal Detect threshold is set to transition from a high to low state between the minimum receiver input optical power and -45 dBm avg. input optical power indicating a definite optical fault (e.g. unplugged connector for the receiver or transmitter, broken fiber, or failed far-end transmitter or data source). The Signal Detect does not detect receiver data error or error-rate. Data errors can be determined by signal processing offered by upstream PHY ICs.

Electromagnetic Interference (EMI)

One of a circuit board designer's foremost concerns is the control of electromagnetic emissions from electronic equipment. Success in controlling generated Electro-

magnetic Interference (EMI) enables the designer to pass a governmental agency's EMI regulatory standard and more importantly, it reduces the possibility of interference to neighboring equipment. Avago Technologies has designed the AFCT-5971LZ/ALZ to provide excellent EMI performance. The EMI performance of a chassis is dependent on physical design and features which help improve EMI suppression. Avago Technologies encourages using standard RF suppression practices and avoiding poorly EMI-sealed enclosures.

Avago Technologies' LC transceivers (AFCT-5971LZ/ALZ) have nose shields which provide a convenient chassis connection to the nose of the transceiver. This nose shield improves system EMI performance by effectively closing off the LC aperture. The recommended transceiver position, PCB layout and panel opening for these devices are the same, making them mechanically drop-in compatible. Figure 8 shows the recommended positioning of the transceivers with respect to the PCB and faceplate.

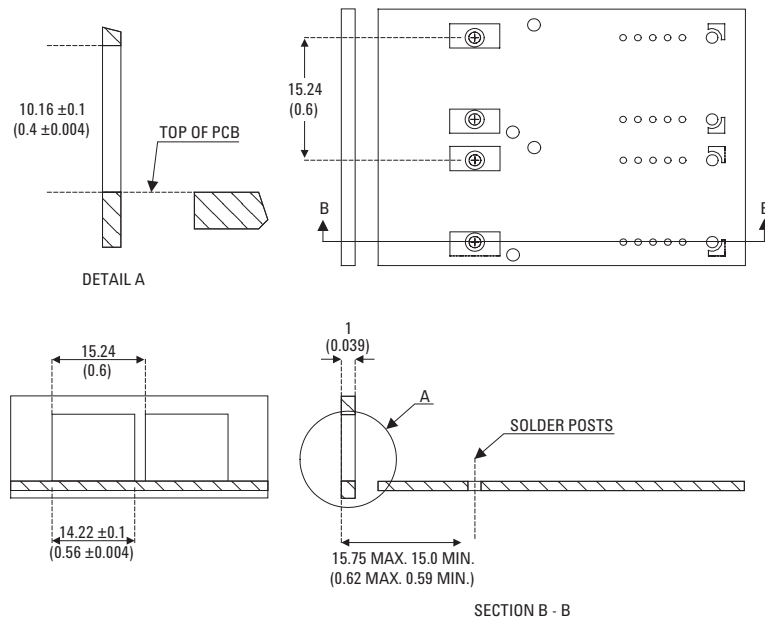

DIMENSIONS IN MILLIMETERS (INCHES)

1. FIGURE DESCRIBES THE RECOMMENDED FRONT PANEL OPENING FOR A LC OR SG SFF TRANSCEIVER.
2. SFF TRANSCEIVER PLACED AT 15.24 mm (0.6) MIN. SPACING.

Figure 8. Recommended Panel Mounting

Recommended Solder and Wash Process

The AFCT-5971LZ/ALZ are compatible with industry-standard wave solder processes.

Process plug

This transceiver is supplied with a process plug for protection of the optical port within the LC connector receptacle. This process plug prevents contamination during wave solder and aqueous rinse as well as during handling, shipping and storage. It is made of a high-temperature, molded sealing material that can withstand +85°C and a rinse pressure of 110 lbs per square inch.

The process plug should only be used once. After removing it from the transceiver, it must not be used again as a process plug; however, if it has not been contaminated it can be reused as a dust cover.

Recommended Solder fluxes

Solder fluxes used with the AFCT-5971LZ/ALZ should be water-soluble, organic fluxes. Recommended solder fluxes include Lonco 3355-11 from London Chemical West, Inc. of Burbank, CA, and 100 Flux from Alpha-Metals of Jersey City, NJ.

Recommended Cleaning/Degreasing Chemicals

Alcohols: methyl, isopropyl, isobutyl.

Aliphatics: hexane, heptane

Other: naphtha.

Do not use partially halogenated hydrocarbons such as 1,1,1 trichloroethane, ketones such as MEK, acetone, chloroform, ethyl acetate, methylene dichloride, phenol, methylene chloride, or N-methylpyrrolidone. Also, Avago Technologies does not recommend the use of cleaners that use halogenated hydrocarbons because of their potential environmental harm.

LC SFF Cleaning Recommendations

In the event of contamination of the optical ports, the recommended cleaning process is the use of forced nitrogen. If contamination is thought to have remained, the optical ports can be cleaned using a NTT international Cletop stick type (diam. 1.25 mm) and HFE7100 cleaning fluid.

Regulatory Compliance

The Regulatory Compliance for transceiver performance is shown in Table 1. The overall equipment design will determine the certification level. The transceiver performance is offered as a figure of merit to assist the designer in considering their use in equipment designs.

Table 1: Regulatory Compliance - Targeted Specification

| Feature | Test Method | Performance |
|--|--|---|
| Electrostatic Discharge (ESD) to the Electrical Pins | MIL-STD-883 Method 3015 | Class 1 (>500 V). |
| Electrostatic Discharge (ESD) to the LC Receptacle | Variation of IEC 61000-4-2 | Tested to 8 kV contact discharge. |
| Electromagnetic Interference (EMI) | FCC Class B | Margins are dependent on customer board and chassis designs. |
| Immunity | Variation of IEC 61000-4-3 | Typically show no measurable effect from a 10 V/m field swept from 27 to 1000 MHz applied to the transceiver without a chassis enclosure. |
| Laser Eye Safety and Equipment Type Testing | FDA CDRH 21-CFR 1040 Class 1 IEC 60825-1 Amendment 2 2001-01 | Accession Number: 9521220-133 License Number: 933/21203530/05 |
| Component Recognition | Underwriters Laboratories and Canadian Standards Association Joint Component Recognition for Information Technology Equipment Including Electrical Business Equipment. | UL File Number: E173874 |

Electrostatic Discharge (ESD)

There are two design cases in which immunity to ESD damage is important.

The first case is during handling of the transceiver prior to mounting it on the circuit board. It is important to use normal ESD handling precautions for ESD sensitive devices. These precautions include using grounded wrist straps, work benches, and floor mats in ESD controlled areas.

The second case to consider is static discharges to the exterior of the equipment chassis containing the transceiver parts. To the extent that the LC connector receptacle is exposed to the outside of the equipment chassis it may be subject to whatever system-level ESD test criteria that the equipment is intended to meet.

Electromagnetic Interference (EMI)

Most equipment designs utilizing these high-speed transceivers from Avago Technologies will be required to meet FCC regulations in the United States, CENELEC EN55022 (CISPR 22) in Europe and VCCI in Japan. Refer to EMI section (page 9) for more details.

Immunity

Transceivers will be subject to radio-frequency electromagnetic fields following the IEC 61000-4-3 test method.

Eye Safety

These laser-based transceivers are classified as AEL Class I (U.S. 21 CFR(J) and AEL Class 1 per EN 60825-1 (+A11).

They are eye safe when used within the data sheet limits per CDRH. They are also eye safe under normal operating conditions and under all reasonably foreseeable single fault conditions per EN60825-1. Avago Technologies has tested the transceiver design for compliance with the requirements listed below under normal operating conditions and under single fault conditions where applicable. TUV Rheinland has granted certification to these transceivers for laser eye safety and use in EN 60825-2 applications. Their performance enables the transceivers to be used without concern for eye safety up to 3.5 V transmitter V_{CC} .

CAUTION:

There are no user serviceable parts nor any maintenance required for the AFCT-5971LZ/ALZ. All adjustments are made at the factory before shipment to our customers. Tampering with or modifying the performance of the parts will result in voided product warranty. It may also result in improper operation of the circuitry, and possible overstress of the laser source. Device degradation or product failure may result.

Connection of the devices to a non-approved optical source, operating above the recommended absolute maximum conditions or operating the AFCT-5971LZ/ALZ in a manner inconsistent with its design and function may result in hazardous radiation exposure and may be considered an act of modifying or manufacturing a laser product. The person(s) performing such an act is required by law to recertify and reidentify the laser product under the provisions of U.S. 21 CFR (Subchapter J).

Absolute Maximum Ratings

Stresses in excess of the absolute maximum ratings can cause catastrophic damage to the device. Limits apply to each parameter in isolation, all other parameters having values within the recommended operating conditions. It should not be assumed that limiting values of more than one parameter can be applied to the product at the same time. Exposure to the absolute maximum ratings for extended periods can adversely affect device reliability.

| Parameter | Symbol | Min. | Typ. | Max. | Unit | Reference |
|--------------------------|-----------------------------------|------|------|-----------------|--------|-----------|
| Wave Soldering Temp/Time | $T_{\text{SOLD}}/t_{\text{sold}}$ | | | +260/10 | °C/sec | |
| Aqueous Wash | P | | | 110 | psi | |
| Storage Temperature | T_{S} | -40 | | +85 | °C | |
| Supply Voltage | V_{CC} | -0.5 | | 3.6 | V | |
| Data Input Voltage | V_{I} | -0.5 | | V_{CC} | V | |
| Data Output Current | I_{D} | | | 50 | mA | |
| Relative Humidity | RH | | | 85 | % | |

Recommended Operating Conditions

| Parameter | Symbol | Min. | Typ. | Max. | Unit | Reference |
|--|-----------------------|------|------|------|-------------------|-----------|
| Ambient Operating Temperature | | | | | | |
| AFCT-5971LZ | T_{A} | 0 | | +70 | °C | 1 |
| AFCT-5971ALZ | T_{A} | -40 | | +85 | °C | 1 |
| Supply Voltage | V_{CC} | 3.1 | | 3.5 | V | 2 |
| Power Supply Noise Rejection | PSNR | | 100 | | mV _{P-P} | 3 |
| Transmitter Differential Input Voltage | V_{D} | 0.3 | | 1.6 | V | |
| Data Output Load | R_{DL} | | 50 | | W | |
| Transmit Disable Input Voltage - Low | T_{DIS} | | | 0.6 | V | |
| Transmit Disable Input Voltage - High | T_{DIS} | 2.2 | | | V | |
| Transmit Disable Assert Time | T_{ASSERT} | | | 10 | μs | 4 |
| Transmit Disable Deassert Time | T_{DEASSERT} | | | 1.0 | ms | 5 |

Transmitter Electrical Characteristics

AFCT-5971LZ: $T_{\text{A}} = 0\text{ °C to }+70\text{ °C}$, $V_{\text{CC}} = 3.1\text{ V to }3.5\text{ V}$

AFCT-5971ALZ: $T_{\text{A}} = -40\text{ °C to }+85\text{ °C}$, $V_{\text{CC}} = 3.1\text{ V to }3.5\text{ V}$

| Parameter | Symbol | Min. | Typ. | Max. | Unit | Reference |
|---|---------------------------------|------|------|------|------|-----------|
| Supply Current | I_{CCT} | | 57 | 140 | mA | |
| Power Dissipation | P_{DIST} | | | 0.5 | W | |
| Data Input Voltage Swing (single-ended) | $V_{\text{IH}} - V_{\text{IL}}$ | 250 | | 930 | mV | |
| Transmitter Differential | | | | | | |
| Data Input Current - Low | I_{IL} | -350 | | | μA | |
| Transmitter Differential | | | | | | |
| Data Input Current - High | I_{IH} | | | 350 | μA | |

Notes:

1. Ambient operating temperature utilizes air flow of 2 ms^{-1} over the device.
2. The transceiver is class 1 eye safe up to $V_{\text{CC}} = 3.5\text{ V}$.
3. Tested with a sinusoidal signal in the frequency range from 10 Hz to 1 MHz on the V_{CC} supply with the recommended power supply filter in place. Typically less than a 1 dB change in sensitivity is experienced.
4. Time delay from Transmit Disable Assertion to laser shutdown.
5. Time delay from Transmit Disable Deassertion to laser startup.

Receiver Electrical Characteristics

AFCT-5971LZ: $T_A = 0\text{ }^{\circ}\text{C}$ to $+70\text{ }^{\circ}\text{C}$, $V_{CC} = 3.1\text{ V}$ to 3.5 V

AFCT-5971ALZ: $T_A = -40\text{ }^{\circ}\text{C}$ to $+85\text{ }^{\circ}\text{C}$, $V_{CC} = 3.1\text{ V}$ to 3.5 V

| Parameter | Symbol | Min. | Typ. | Max. | Unit | Reference |
|--|-------------------|-------|------|-------|---------------|-----------|
| Supply Current | I_{CCR} | | 89 | 140 | mA | 6 |
| Power Dissipation | P_{DISR} | | | 0.5 | W | |
| Data Output Voltage Swing (single-ended) | $V_{OH} - V_{OL}$ | 575 | | 930 | mV | 7 |
| Data Output Rise Time | t_r | | | 2.2 | ns | 8 |
| Data Output Fall Time | t_f | | | 2.2 | ns | 8 |
| Signal Detect Output Voltage - Low | $V_{OL} - V_{CC}$ | -1.84 | | -1.6 | V | 9 |
| Signal Detect Output Voltage - High | $V_{OH} - V_{CC}$ | -1.1 | | -0.88 | V | 9 |
| Signal Detect Assert Time (OFF to ON) | AS_{MAX} | | | 100 | μs | |
| Signal Detect Deassert Time (ON to OFF) | ANS_{MAX} | 2.3 | | 100 | μs | |

Notes:

- Includes current for biasing Rx data outputs.
- These outputs are compatible with low voltage PECL inputs.
- These are 20-80% values.
- SD is LVPECL compatible when terminated with $50\ \Omega$ to $V_{CC} - 2\text{ V}$.

Transmitter Optical Characteristics

AFCT-5971LZ: $T_A = 0\text{ }^{\circ}\text{C}$ to $+70\text{ }^{\circ}\text{C}$, $V_{CC} = 3.1\text{ V}$ to 3.5 V

AFCT-5971ALZ: $T_A = -40\text{ }^{\circ}\text{C}$ to $+85\text{ }^{\circ}\text{C}$, $V_{CC} = 3.1\text{ V}$ to 3.5 V

| Parameter | Symbol | Min. | Typ. | Max. | Unit | Reference |
|--|--|------------|------|------------|--------|-----------|
| Output Optical Power 9 μm SMF | P_{OUT} | -15 | | -8 | dBm | 10 |
| Center Wavelength | λ_c | 1261 | | 1360 | nm | |
| Spectral Width - rms | s | | | 7.7 | nm rms | 11 |
| Optical Rise Time | t_r | | | 2 | ns | 12 |
| Optical Fall Time | t_f | | | 2 | ns | 12 |
| Extinction Ratio | E_R | 6 | | | dB | |
| Output Optical Eye | Compliant with eye mask IEEE 802.3ah- 2004 | | | | | 13 |
| RIN | RIN_{12} (OMA) | | -110 | | dB/Hz | |
| Transmitter and Dispersion Penalty | TDP | | | 4.0 | dB | |
| Optical Return Loss | ORL | | | 12 | dB | |
| Signalling Speed | | 125-50 ppm | | 125+50 ppm | MBd | |

Receiver Optical Characteristics

AFCT-5971LZ: $T_A = 0\text{ }^{\circ}\text{C}$ to $+70\text{ }^{\circ}\text{C}$, $V_{CC} = 3.1\text{ V}$ to 3.5 V)

AFCT-5971ALZ: $T_A = -40\text{ }^{\circ}\text{C}$ to $+85\text{ }^{\circ}\text{C}$, $V_{CC} = 3.1\text{ V}$ to 3.5 V)

| Parameter | Symbol | Min. | Typ. | Max. | Unit | Reference |
|----------------------------|---------------------|------|-------|------|----------|-----------|
| Receiver Sensitivity | $P_{IN\text{ MIN}}$ | | | -25 | dBm avg. | 14 |
| Receiver Overload | $P_{IN\text{ MAX}}$ | -8 | 0 | | dBm avg. | |
| Input Operating Wavelength | λ | 1261 | | 1580 | nm | |
| Signal Detect - Asserted | P_A | | -39.8 | -25 | dBm avg. | |
| Signal Detect - Deasserted | P_D | -45 | -41.9 | | dBm avg. | |
| Signal Detect - Hysteresis | P_H | 0.5 | 1.39 | 4 | dB | |

Notes:

10. The output power is coupled into a 1 m single mode fiber. Minimum output optical level is at end of life.
11. The relationship between FWHM and RMS values for spectral width can be derived from the assumption of a Gaussian shaped spectrum which results in $RMS = FWHM/2.35$.
12. These are unfiltered 10-90% values.
13. Mask coordinates (X1, X2, X3, Y1, Y2, Y3, Y4) = (0.18, 0.29, 0.35, 0.35, 0.38, 0.4, 0.55).
14. Minimum sensitivity for IEEE 802.3ah test pattern with baseline wander.

Ordering Information

1300 nm FP Laser (Temperature range 0 °C to +70 °C,

AFCT-5971LZ = 2 x 5 LC connector, IR, LVPECL SD with EMI nose shield

1300 nm FP Laser (Temperature range -40°C to +85 °C,

AFCT-5971ALZ = 2 x 5 LC connector, IR, LVPECL SD with EMI nose shield

Class 1 Laser Product: This product conforms to the applicable requirements of 21 CFR 1040 at the date of manufacture

Date of Manufacture: _____

Avago Technologies Inc., No 1 Yishun Ave 7, Singapore

Handling Precautions

1. The AFCT-5971LZ/ALZ can be damaged by current surges or overvoltage. Power supply transient precautions should be taken.
2. Normal handling precautions for electrostatic sensitive devices should be taken.

For product information and a complete list of distributors, please go to our web site: www.avagotech.com

Avago, Avago Technologies, and the A logo are trademarks of Avago Technologies, Limited in the United States and other countries. Data subject to change. Copyright © 2006 Avago Technologies Limited. All rights reserved. Obsoletes AV01-0207EN AV02-0638EN - July 31, 2007

Avago
TECHNOLOGIES

Looking for pricing, stock, or lifecycle information?

Click below to explore more details on WIN SOURCE:

- ⊖ [View AFCT-5971ALZ on WIN SOURCE](#)
- ⊖ [Foxconn Optical Interconnect Technology, Inc. Information](#)

Optimize Your Supply Chain with WIN SOURCE Solutions

- ✓ Global Sourcing Solution
- ✓ Obsolete Management
- ✓ Cost Control Management
- ✓ Shortage Management
- ✓ Alternative Solution
- ✓ Excess Inventory Management