



**THE DATASHEET OF
LM3492HCMHX/NOPB**



LM3492HC/-Q1 Two-Channel, Individual Dimmable, LED Driver With Boost Converter and Fast Current Regulator

1 Features

- Boost Converter
 - Automotive Grade Product, Q100 Grade-1 Qualified
 - Very Wide Input Voltage Range: 4.5 V to 65 V
 - Programmable Soft-Start Period
 - No Loop Compensation Required
 - Stable with Ceramic and Other Low ESR Capacitors with No Audible Noise
 - Nearly Constant Switching Frequency Programmable from 200 kHz to 1 MHz
- Current Regulator
 - Programmable LED Current: 50 mA to 250 mA
 - 10000:1 Contrast Ratio, 300-ns Minimum Pulse Width
 - Two Individual Dimmable LED Strings up to 65 V, Total 15 W (Typically 28 LEDs at 150 mA)
 - Dynamic Headroom Control Maximizes Efficiency
 - Over-Power Protection
 - $\pm 3\%$ Current Accuracy
- Supervisory Functions
 - Precision Enable
 - COMM I/O Pin for Diagnostic and Commands
 - Thermal Shutdown Protection
 - Thermally Enhanced PWP, 20-Pin Package

2 Applications

- Ultra-High Contrast Ratio 6.5" to 10" LCD Display Backlight up to 28 LEDs
- Automotive or Marine GPS Display

3 Description

The LM3492HC/-Q1 device integrates a boost converter and a two-channel current regulator to implement a highly efficient and cost effective LED driver. This device drives two individually dimmable LED strings with a maximum power of 15 W and an output voltage of up to 65 V. The boost converter employs a proprietary projected-on-time control method to give a fast transient response with no compensation required. The nearly constant switching frequency can be set to a level from 200 kHz to 1 MHz. Ceramic capacitors stabilize the application circuit and produce no audible noise on dimming. The programmable peak current limit and soft-start features reduce current surges at start-up. An integrated, 190-m Ω , 3.9-A, N-Channel MOSFET switch minimizes the solution size. The fast slew rate current regulator allows high frequency and narrow pulse width dimming signals to achieve a very high contrast ratio of 10000:1. The LED current can be set from 50 mA to 250 mA by a single resistor.

Device Information⁽¹⁾

| PART NUMBER | PACKAGE | BODY SIZE (NOM) |
|-------------|----------|-------------------|
| LM3492HC | PWP (20) | 6.50 mm x 4.40 mm |
| LM3492HC-Q1 | | |

(1) For all available packages, see the orderable addendum at the end of the data sheet.

Simplified Application

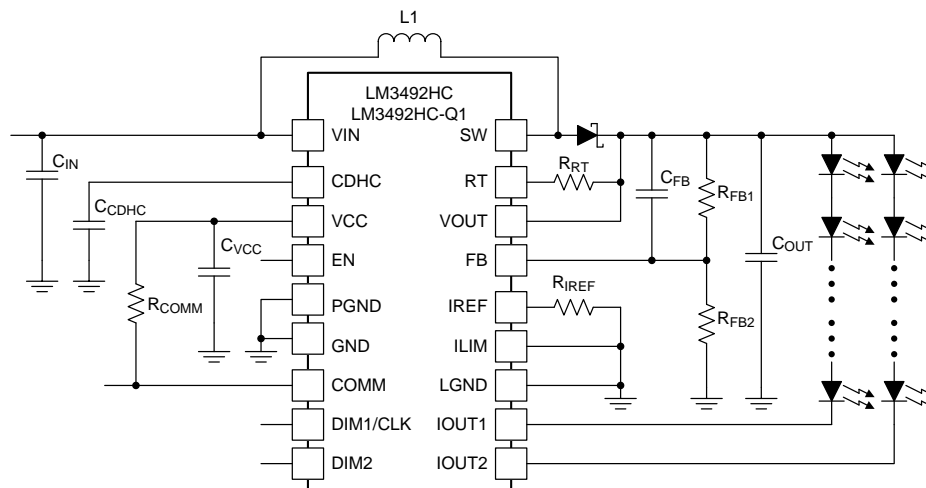

Table of Contents

| | | | |
|--|-----------|--|-----------|
| 1 Features | 1 | 8.4 Device Functional Modes..... | 17 |
| 2 Applications | 1 | 8.5 Programming | 18 |
| 3 Description | 1 | 9 Application and Implementation | 19 |
| 4 Revision History | 2 | 9.1 Application Information..... | 19 |
| 5 Description (continued) | 3 | 9.2 Typical Application | 19 |
| 6 Pin Configuration and Functions | 3 | 10 Power Supply Recommendations | 22 |
| 7 Specifications | 4 | 11 Layout | 22 |
| 7.1 Absolute Maximum Ratings | 4 | 11.1 Layout Guidelines | 22 |
| 7.2 ESD Ratings..... | 4 | 11.2 Layout Example | 22 |
| 7.3 Recommended Operating Conditions..... | 4 | 12 Device and Documentation Support | 23 |
| 7.4 Thermal Information | 5 | 12.1 Related Links | 23 |
| 7.5 Electrical Characteristics..... | 5 | 12.2 Community Resources..... | 23 |
| 7.6 Typical Characteristics..... | 7 | 12.3 Trademarks | 23 |
| 8 Detailed Description | 11 | 12.4 Electrostatic Discharge Caution..... | 23 |
| 8.1 Overview | 11 | 12.5 Glossary | 23 |
| 8.2 Functional Block Diagram | 11 | 13 Mechanical, Packaging, and Orderable Information | 23 |
| 8.3 Feature Description..... | 12 | | |

4 Revision History

NOTE: Page numbers for previous revisions may differ from page numbers in the current version.

Changes from Revision A (May 2013) to Revision B

Page

- Added *Pin Configuration and Functions* section, *ESD Rating* table, *Feature Description* section, *Device Functional Modes*, *Application and Implementation* section, *Power Supply Recommendations* section, *Layout* section, *Device and Documentation Support* section, and *Mechanical, Packaging, and Orderable Information* section **1**

5 Description (continued)

To maximize the efficiency, *dynamic headroom control* (DHC) automatically adjusts the output voltage to a minimum. The DHC also facilitates a single BOM for different number of LED in a string, which is required for back-light panels of different size, thereby reducing overall development time and cost. The LM3492HC device includes a COMM pin that serves as a bidirectional I/O pin. The versatile COMM pin interface with an external micro-controller unit (MCU) is used for the following functions: power-good, overtemperature, IOU2 overvoltage and undervoltage indications, switching frequency tuning, and channel 1 disabling. Other supervisory functions of the device include precise enable, VCC undervoltage lockout, current regulator over-power protection, and thermal shutdown protection. The device is available in the thermally enhanced PWP, 20-pin package.

6 Pin Configuration and Functions

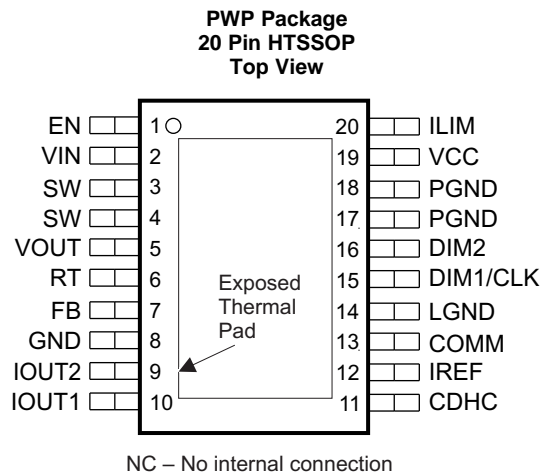

Pin Functions

| PIN | | TYPE ⁽¹⁾ | DESCRIPTION |
|----------|-----|---------------------|---|
| NAME | NO. | | |
| CDHC | 11 | I | Dynamic headroom control. An external capacitor connected to this pin sets the DHC sensitivity. At start-up, a 12- μ A internal current source charges an external capacitor to provide a soft-start function. |
| COMM | 13 | I/O | Bidirectional logic communication. This pin is open drain for various indications (power-good, overtemperature, IOU2 overvoltage and undervoltage) and command sending (switching frequency tuning and channel 1 disabling). |
| DIM1/CLK | 15 | I/O | Dimming control of channel 1. Control the on and off of the current regulator of channel 1. This pin is internally pulled low by a 5- μ A current. This pin also serves as a clock signal for latching input and output data of the COMM pin. |
| DIM2 | 16 | I | Dimming control of channel 2. Control the on and off of the current regulator of channel 2. This pin is internally pulled low by a 5- μ A current. |
| EN | 1 | I | Enable input. Contains an internal pullup. Connect to a voltage higher than 1.63 V to provide precision enable for the device. |
| FB | 7 | I | Output voltage feedback. The output voltage is connected to this pin through a feedback resistor divider for output voltage regulation. The voltage of this pin is from 1.05 V to 2.5 V. |
| GND | 8 | G | Analog signal ground. Connect to the exposed pad directly beneath the device. |
| ILIM | 20 | I | Peak current limit adjust. Connecting an external resistor from the ILIM pin to the VCC pin reduces peak current limit. Connect the ILIM pin to ground to obtain the maximum current limit. |
| IOUT1 | 10 | I | Current regulator input for channel 1. Input of the current regulator of channel 1. The regulated current is programmable (see the IREF pin). |
| IOUT2 | 9 | I | Current regulator input for channel 2. Input of the current regulator of channel 2. The regulated current is programmable (see the IREF pin). |
| IREF | 12 | I | Current setting pin for the current regulators. An external resistor connected from this pin to ground programs the regulated current of the current regulator of channels 1 and 2. |

(1) I = Input, O = Output, G = Ground

Pin Functions (continued)

| PIN | | TYPE ⁽¹⁾ | DESCRIPTION |
|-------------|-----|---------------------|--|
| NAME | NO. | | |
| LGND | 14 | G | Current regulator ground. Must be connected to the GND pin and exposed pad for normal operation. The LGND and GND pins are not internally connected. |
| PGND | 17 | G | Integrated MOSFET ground. Must be connected to the GND pin and exposed pad for normal operation. The PGND and GND pins are not internally connected. |
| | 18 | | |
| RT | 6 | I | Frequency control pin. An external resistor from the VOUT pin to this pin sets the switching frequency. |
| SW | 3 | I | Switch node. Internally connected to the drain of the integrated MOSFET. |
| | 4 | | |
| VCC | 19 | O | Internal LED regulator output. Nominally regulated to 5.5 V. Connect a capacitor of 0.47- μ F or larger between the VCC and GND pins. |
| VIN | 2 | I | Input supply voltage pin. Input voltage range is from 4.5 V to 65 V. |
| VOUT | 5 | I | Output voltage sense pin. Senses the output voltage for nearly constant switching frequency control. |
| Exposed Pad | | G | Thermal connection pad. Connect to a ground plane. |

7 Specifications

7.1 Absolute Maximum Ratings

over operating free-air temperature range (unless otherwise noted) ⁽¹⁾

| | | MIN | MAX | UNIT |
|---------------------------------------|---------------------------------|------|-----|------|
| Input voltage | VIN, RT, VOUT to GND, SW to GND | -0.3 | 67 | V |
| | SW to GND (transient <100 ns) | | -2 | |
| Output voltage | ILIM to GND | -0.3 | 1 | V |
| | FB to GND | -0.3 | 5 | |
| | COMM, DIM1, DIM2, to GND | -0.3 | 6 | |
| Junction temperature, T _J | | | 150 | °C |
| Storage temperature, T _{stg} | | -65 | 150 | |

(1) Stresses beyond those listed under *Absolute Maximum Ratings* may cause permanent damage to the device. These are stress ratings only, which do not imply functional operation of the device at these or any other conditions beyond those indicated under *Recommended Operating Conditions*. Exposure to absolute-maximum-rated conditions for extended periods may affect device reliability.

7.2 ESD Ratings

| | | VALUE | UNIT |
|--------------------|-------------------------|--|-------|
| V _(ESD) | Electrostatic discharge | Human-body model (HBM), per ANSI/ESDA/JEDEC JS-001 ⁽¹⁾ | ±2000 |
| | | Charged-device model (CDM), per JEDEC specification JESD22-C101 ⁽²⁾ | ±750 |

(1) JEDEC document JEP155 states that 500-V HBM allows safe manufacturing with a standard ESD control process. Pins listed as ±2000 V may actually have higher performance.

(2) JEDEC document JEP157 states that 250-V CDM allows safe manufacturing with a standard ESD control process. Pins listed as ±750 V may actually have higher performance.

7.3 Recommended Operating Conditions

over operating free-air temperature range (unless otherwise noted)

| | MIN | NOM | MAX | UNIT |
|---------------------------------------|-----|-----|-----|------|
| Supply input voltage, V _{IN} | 4.5 | | 65 | V |
| Junction temperature, T _J | -40 | | 125 | °C |

7.4 Thermal Information

| THERMAL METRIC ⁽¹⁾ | | LM3492HC | UNIT |
|-------------------------------|--|-----------------|------|
| | | PWP (HTSSOP) | |
| | | 20 PINS | |
| R _{θJA} | Junction-to-ambient thermal resistance | 36.8 | °C/W |
| R _{θJC(top)} | Junction-to-case (top) thermal resistance | 21.8 | °C/W |
| R _{θJB} | Junction-to-board thermal resistance | 18.3 | °C/W |
| Ψ _{JT} | Junction-to-top characterization parameter | 0.6 | °C/W |
| Ψ _{JB} | Junction-to-board characterization parameter | 18.1 | °C/W |
| R _{θJC(bot)} | Junction-to-case (bottom) thermal resistance | 2 | °C/W |

(1) For more information about traditional and new thermal metrics, see the *Semiconductor and IC Package Thermal Metrics* application report, [SPRA953](#).

7.5 Electrical Characteristics

over operating free-air temperature range, V_{IN} = 12 V (unless otherwise noted)

| PARAMETER | | TEST CONDITIONS | MIN | TYP | MAX | UNIT |
|-------------------------------------|--|--|-------|-------|-------|------|
| START-UP REGULATOR (VCC PIN) | | | | | | |
| V _{VCC} | Output voltage | C _{VCC} = 0.47 μF, no load | 4.7 | 5.5 | 6.3 | V |
| | | I _{VCC} = 2 mA | 4.7 | 5.5 | 6.3 | V |
| V _{CC_UVLO} | VCC pin undervoltage lockout threshold (UVLO) | V _{VCC} increasing, T _A = T _J = 25°C | 3.56 | 3.78 | 4 | V |
| V _{CC_UVLO-HYS} | VCC pin UVLO hysteresis | V _{VCC} decreasing, T _A = T _J = 25°C | | 310 | | mV |
| I _{IN} | I _{IN} operating current | No switching, V _{FB} = 0 V | | 3.6 | 5.2 | mA |
| I _{IN-SD} | I _{IN} operating current, device shutdown | V _{EN} = 0 V | | 30 | 95 | μA |
| I _{VCC} | VCC pin current limit ⁽¹⁾ | V _{VCC} = 0 V | 18 | 30 | | mA |
| V _{CC-VOUT} | VCC pin output voltage when supplied by VOUT | V _{IN} = Open, I _{VCC} = 1 mA, V _{OUT} = 18 V | 3.5 | 4.1 | 4.7 | V |
| ENABLE INPUT | | | | | | |
| V _{EN} | EN pin input threshold | V _{EN} rising | 1.55 | 1.63 | 1.71 | V |
| V _{EN-HYS} | EN pin threshold hysteresis | V _{EN} falling | | 194 | | mV |
| I _{EN-SHUT} | Enable pullup current at shutdown | V _{EN} = 0 V | | 2 | | μA |
| I _{EN-OPER} | Enable pullup current during operation | V _{EN} = 2 V | | 40 | | μA |
| CURRENT REGULATOR | | | | | | |
| V _{IREF} | IREF pin voltage | 4.5 V ≤ V _{IN} ≤ 65 V | 1.231 | 1.256 | 1.281 | V |
| V _{DHC50} | V _{IOUT} under DHC | I _{OUT} = 50 mA, R _{IREF} = 25 kΩ | 0.160 | 0.225 | 0.290 | V |
| V _{DHC100} | | I _{OUT} = 100 mA, R _{IREF} = 12.5 kΩ | 0.38 | 0.48 | 0.58 | |
| V _{DHC200} | | I _{OUT} = 200 mA, R _{IREF} = 6.25 kΩ | 0.81 | 0.99 | 1.17 | |
| V _{DHC250} | | I _{OUT} = 250 mA, R _{IREF} = 5 kΩ | 0.81 | 1.21 | 1.44 | |

(1) The VCC pin provides self bias for the internal gate drive and control circuits. Device thermal limitations limit external loading.

Electrical Characteristics (continued)

 over operating free-air temperature range, $V_{IN} = 12\text{ V}$ (unless otherwise noted)

| PARAMETER | | TEST CONDITIONS | MIN | TYP | MAX | UNIT |
|------------------------|---|--|-------|-------|-------|---------------|
| I_{OUT50} | Current output under DHC | $V_{IOUT} = V_{DHC50}$, $R_{IREF} = 25\text{ k}\Omega$, $T_A = T_J = 25^\circ\text{C}$ | 47.5 | 50 | 52.5 | mA |
| | | $V_{IOUT} = V_{DHC50}$, $R_{IREF} = 25\text{ k}\Omega$ | 46.5 | 50 | 53.5 | |
| I_{OUT100} | | $V_{IOUT} = V_{DHC100}$, $R_{IREF} = 12.5\text{ k}\Omega$, $T_A = T_J = 25^\circ\text{C}$ | 97 | 100 | 103 | |
| | | $V_{IOUT} = V_{DHC100}$, $R_{IREF} = 12.5\text{ k}\Omega$ | 96 | 100 | 104 | |
| I_{OUT200} | | $V_{IOUT} = V_{DHC200}$, $R_{IREF} = 6.25\text{ k}\Omega$, $T_A = T_J = 25^\circ\text{C}$ | 194 | 200 | 206 | |
| | | $V_{IOUT} = V_{DHC200}$, $R_{IREF} = 6.25\text{ k}\Omega$ | 192 | 200 | 208 | |
| I_{OUT250} | | $V_{IOUT} = V_{DHC250}$, $R_{IREF} = 5\text{ k}\Omega$, $T_A = T_J = 25^\circ\text{C}$ | 241.3 | 250 | 258.8 | |
| | | $V_{IOUT} = V_{DHC250}$, $R_{IREF} = 5\text{ k}\Omega$ | 238 | 250 | 262 | |
| I_{OUTOFF} | Leakage at maximum work voltage | $V_{DIM} = 0$, $V_{IOUT} = 65\text{ V}$ | | | 5 | μA |
| $V_{IOUT50-MIN}$ | Minimum work voltage | $I_{OUT} = 50\text{ mA}$, $R_{IREF} = 25\text{ k}\Omega$, $I_{OUT} = 0.98 \times I_{OUT50}$, $T_A = T_J = 25^\circ\text{C}$ | | 0.1 | 0.15 | V |
| $V_{IOUT100-MIN}$ | | $I_{OUT} = 100\text{ mA}$, $R_{IREF} = 12.5\text{ k}\Omega$, $I_{OUT} = 0.98 \times I_{OUT100}$, $T_A = T_J = 25^\circ\text{C}$ | | 0.2 | 0.35 | |
| $V_{IOUT200-MIN}$ | | $I_{OUT} = 200\text{ mA}$, $R_{IREF} = 6.25\text{ k}\Omega$, $I_{OUT} = 0.98 \times I_{OUT200}$, $T_A = T_J = 25^\circ\text{C}$ | | 0.4 | 0.65 | |
| $V_{IOUT250-MIN}$ | | $I_{OUT} = 250\text{ mA}$, $R_{IREF} = 5\text{ k}\Omega$, $I_{OUT} = 0.98 \times I_{OUT250}$, $T_A = T_J = 25^\circ\text{C}$ | | 0.5 | 0.82 | |
| $V_{DIM-HIGH}$ | DIM voltage HIGH | | 1.17 | | | V |
| $V_{DIM-LOW}$ | DIM voltage LOW | | | | 0.7 | V |
| BOOST CONVERTER | | | | | | |
| $I_{CDHC-SRC}$ | CDHC pin source current | $V_{CDHC} = 1.6\text{ V}$, $V_{FB} = 3\text{ V}$, $V_{IOUT} = 0\text{ V}$, DIM = High | | 60 | | μA |
| $I_{CDHC-SINK}$ | CDHC pin sink current | $V_{CDHC} = 1.6\text{ V}$, $V_{FB} = 3\text{ V}$, $V_{IOUT} = 3\text{ V}$, DIM = High | | 56 | | μA |
| $I_{CDHC-PULLUP}$ | CDHC pin pullup current | DIM = Low, $V_{CDHC} = 2.3\text{ V}$, $V_{FB} = 3\text{ V}$ | 10 | 200 | 500 | nA |
| I_{CL-MAX} | Integrated MOSFET peak current limit threshold | | 3.3 | 3.9 | 4.5 | A |
| $I_{CL-HALF}$ | Half integrated MOSFET peak current limit threshold | $R_{ILIM} = 11\text{ k}\Omega$ | | 2 | | A |
| $R_{DS(on)}$ | Integrated MOSFET On-resistance | $I_{SW} = 500\text{ mA}$ | | 0.19 | 0.43 | Ω |
| $V_{FBTH-PWRGD}$ | Power-Good FB pin threshold | | | 2.25 | | V |
| V_{FB-OVP} | FB pin overvoltage protection threshold FB pin OVP hysteresis | V_{FB} rising, $V_{CDHC} = 4\text{ V}$ | 2.64 | 2.76 | 2.88 | V |
| | | V_{FB} falling | 0.1 | 0.215 | 0.323 | |
| I_{FB} | Feedback pin input current | $V_{FB} = 3\text{ V}$ | | | 1 | μA |
| t_{ON} | ON timer pulse width | $V_{IN} = 12\text{ V}$, $V_{OUT} = 65\text{ V}$, $R_{RT} = 300\text{ k}\Omega$ | | 1460 | | ns |
| | | $V_{IN} = 24\text{ V}$, $V_{OUT} = 32.5\text{ V}$, $R_{RT} = 300\text{ k}\Omega$ | | 800 | | |
| | | $V_{IN} = 12\text{ V}$, $V_{OUT} = 65\text{ V}$, $R_{RT} = 100\text{ k}\Omega$ | | 550 | | |
| | | $V_{IN} = 24\text{ V}$, $V_{OUT} = 32.5\text{ V}$, $R_{RT} = 100\text{ k}\Omega$ | | 350 | | |
| $t_{ON(min)ILIM}$ | ON timer minimum pulse width at current limit | | | 145 | | ns |
| t_{OFF} | OFF timer pulse width | | | 145 | 350 | ns |

Electrical Characteristics (continued)

over operating free-air temperature range, $V_{IN} = 12\text{ V}$ (unless otherwise noted)

| PARAMETER | TEST CONDITIONS | MIN | TYP | MAX | UNIT | | |
|---------------------------|---|---|-----|-----|------|-----|--------------------|
| COMM PIN | | | | | | | |
| $V_{IOUT-OV}$ | IOUT pin overvoltage threshold | COMM goes LOW during V_{IOUT} rising, other $V_{IOUT} = 1.2\text{ V}$ | | 5.6 | 6.7 | 7.8 | V |
| $V_{COMM-LOW}$ | COMM pin at LOW | 5 mA into COMM | | | | 0.7 | V |
| $I_{LEAK-FAULT}$ | COMM pin open leakage | $V_{COMM} = 5\text{ V}$ | | | | 5 | μA |
| THERMAL PROTECTION | | | | | | | |
| T_{OTM} | Overtemperature indication | T_J rising | | | | 135 | $^{\circ}\text{C}$ |
| $T_{OTM-HYS}$ | Over-temperature indication hysteresis | T_J falling | | | | 15 | $^{\circ}\text{C}$ |
| T_{SD} | Thermal shutdown temperature | T_J rising | | | | 165 | $^{\circ}\text{C}$ |
| T_{SD-HYS} | Thermal shutdown temperature hysteresis | T_J falling | | | | 20 | $^{\circ}\text{C}$ |

7.6 Typical Characteristics

Unless otherwise specified the following conditions apply: $T_J = 25^{\circ}\text{C}$, $V_{IN} = 12\text{ V}$ with configuration in typical application circuit for $I_{LED} = 250\text{ mA}$ shown in this data sheet.

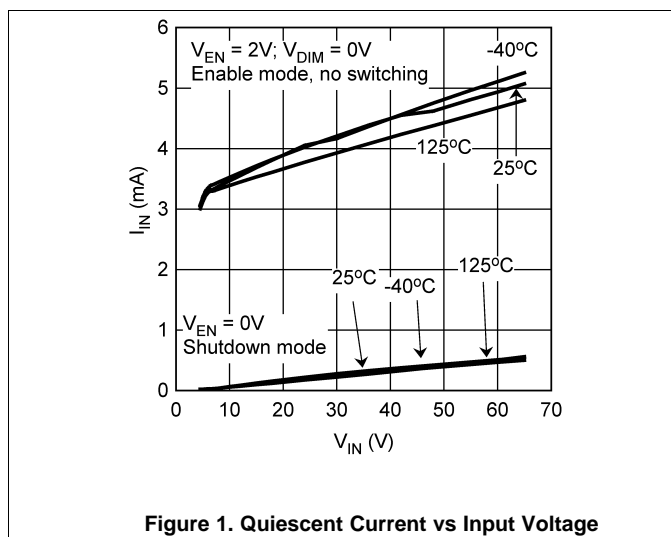

Figure 1. Quiescent Current vs Input Voltage

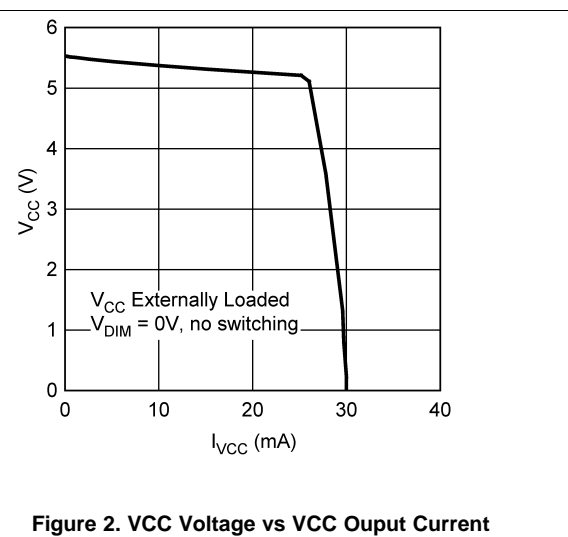

Figure 2. VCC Voltage vs VCC Output Current

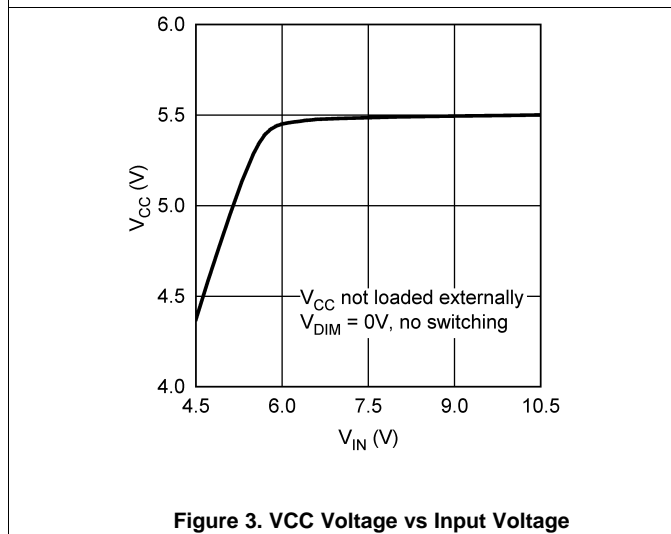

Figure 3. VCC Voltage vs Input Voltage

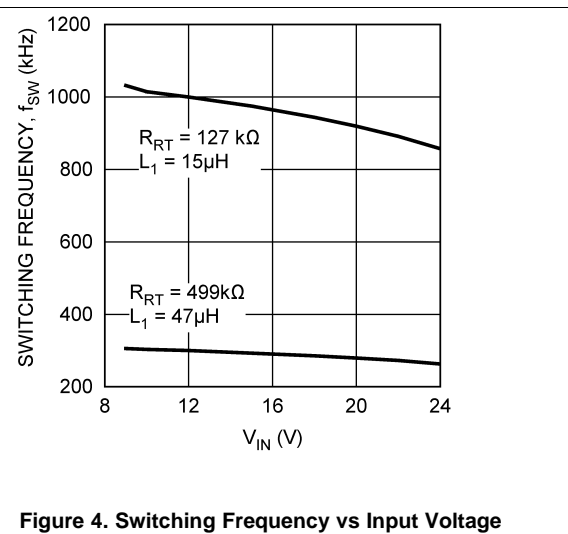

Figure 4. Switching Frequency vs Input Voltage

Typical Characteristics (continued)

Unless otherwise specified the following conditions apply: $T_J = 25^\circ\text{C}$, $V_{IN} = 12\text{ V}$ with configuration in typical application circuit for $I_{LED} = 250\text{ mA}$ shown in this data sheet.

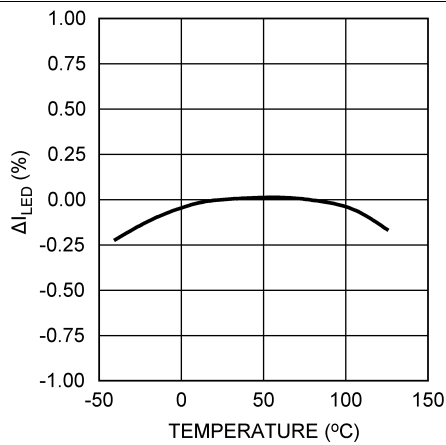

Figure 5. LED Current Regulation vs Temperature

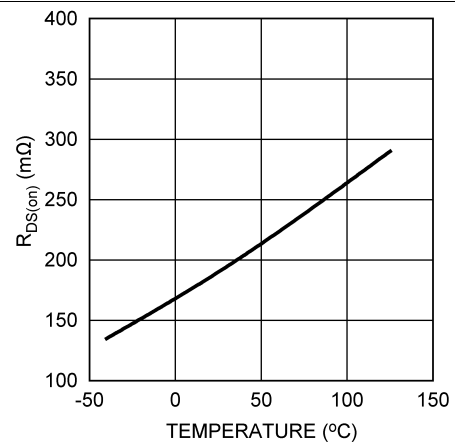
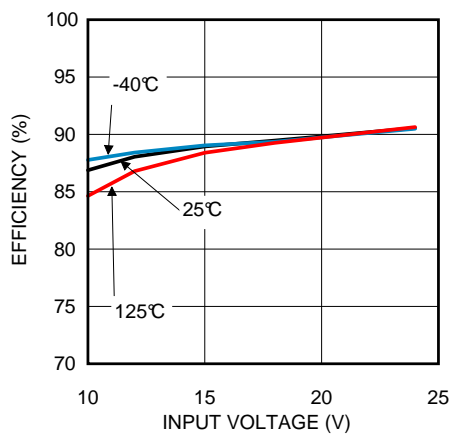
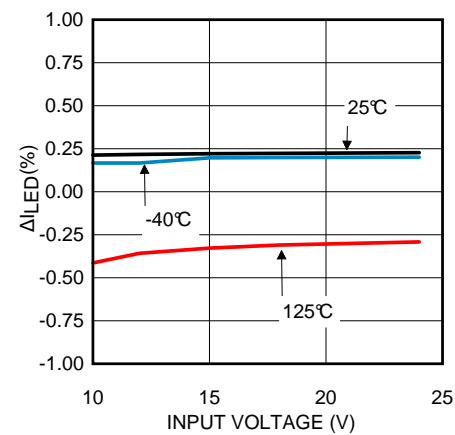

Figure 6. MOSFET On-Resistance vs Temperature



$I_{LED} = 0.25\text{ A}$

Figure 7. Efficiency vs Input Voltage



$I_{LED} = 0.25\text{ A}$

Figure 8. LED Current Regulation vs Input Voltage

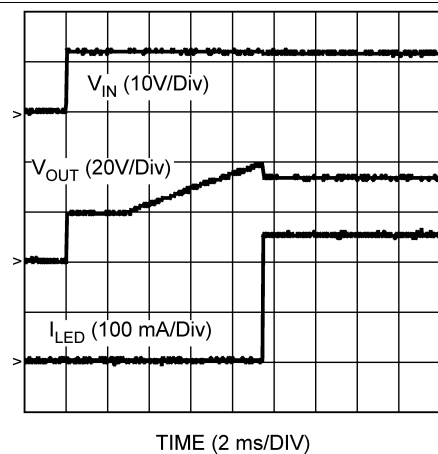

$I_{LED} = 0.25\text{ A}$

Figure 9. Power-Up Waveform

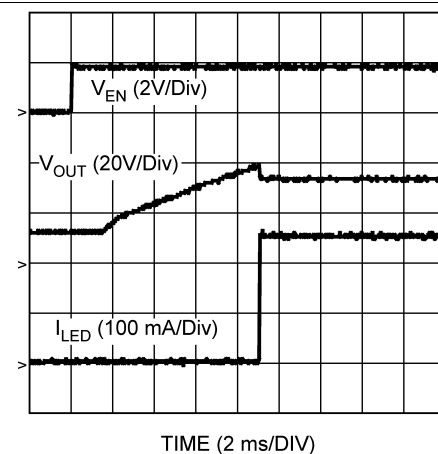

$I_{LED} = 0.25\text{ A}$

Figure 10. Enable Transient Waveform

Typical Characteristics (continued)

Unless otherwise specified the following conditions apply: $T_J = 25^\circ\text{C}$, $V_{IN} = 12\text{ V}$ with configuration in typical application circuit for $I_{LED} = 250\text{ mA}$ shown in this data sheet.

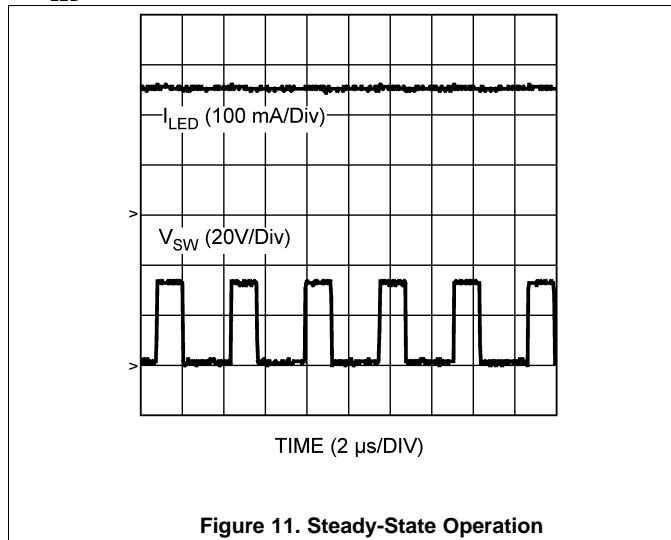

Figure 11. Steady-State Operation

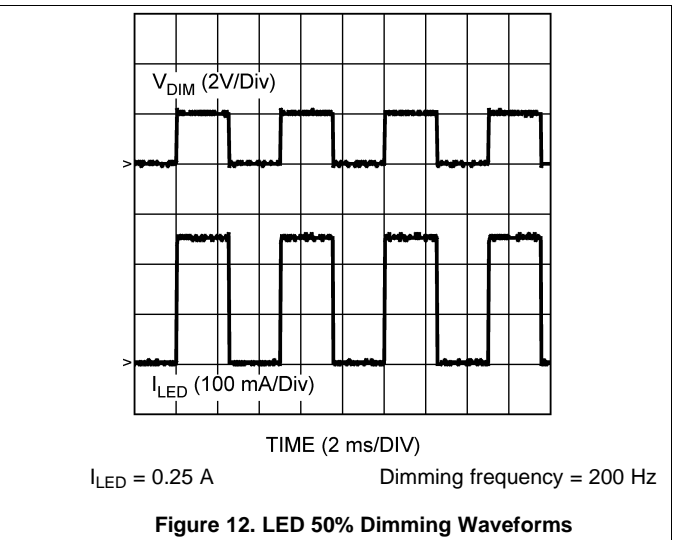

Figure 12. LED 50% Dimming Waveforms

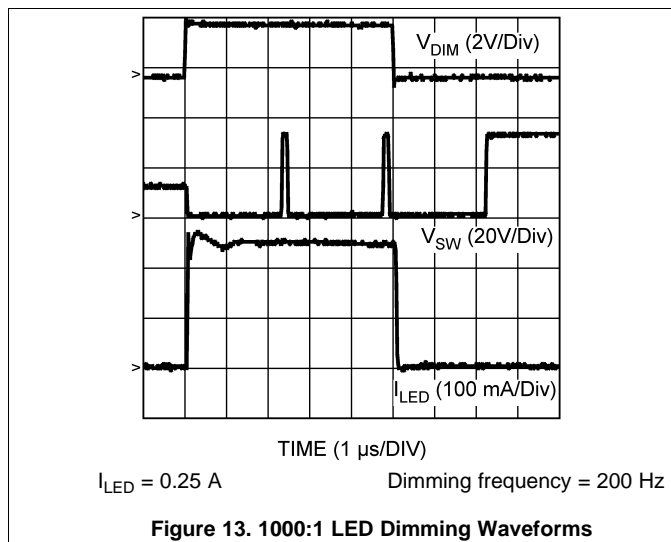

Figure 13. 1000:1 LED Dimming Waveforms

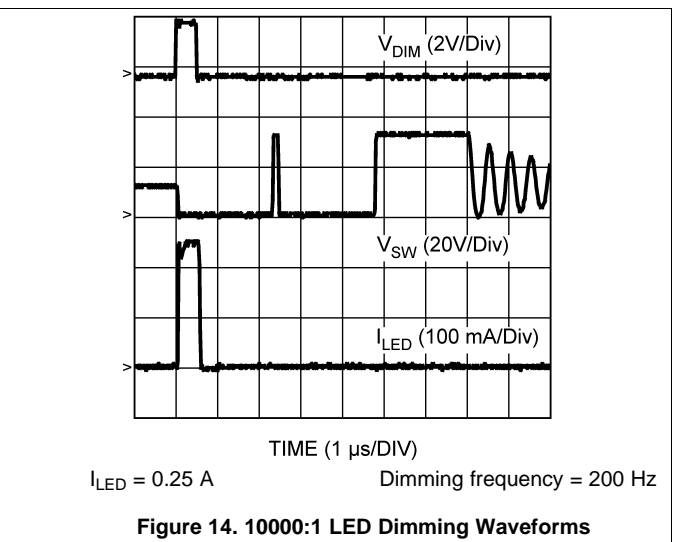

Figure 14. 10000:1 LED Dimming Waveforms

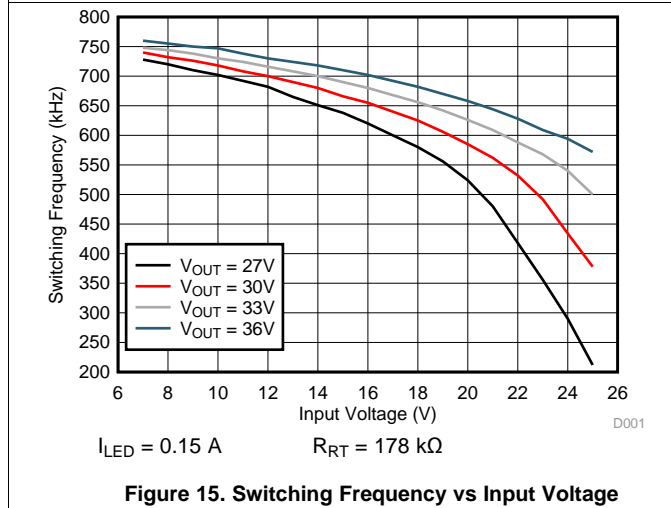

Figure 15. Switching Frequency vs Input Voltage

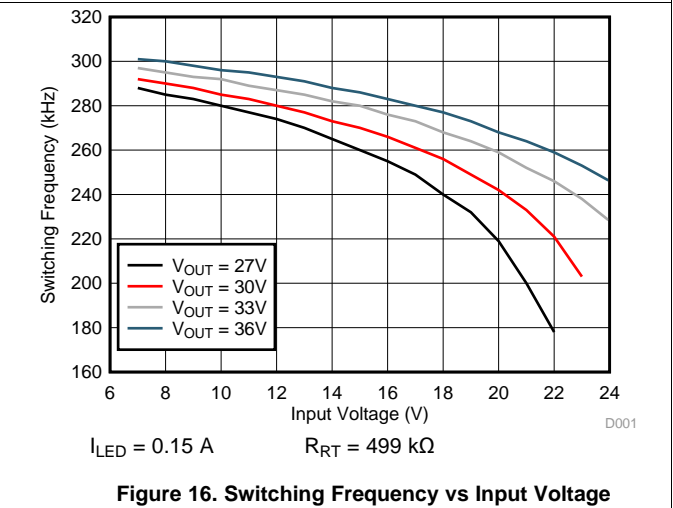
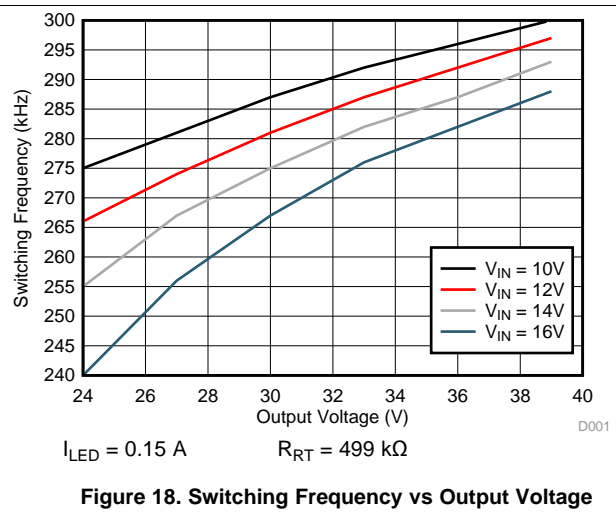
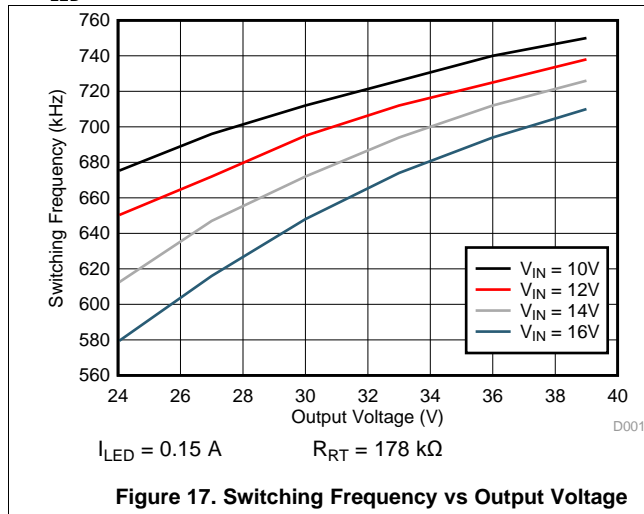

Figure 16. Switching Frequency vs Input Voltage

Typical Characteristics (continued)

Unless otherwise specified the following conditions apply: $T_J = 25^\circ\text{C}$, $V_{IN} = 12\text{ V}$ with configuration in typical application circuit for $I_{LED} = 250\text{ mA}$ shown in this data sheet.



8 Detailed Description

8.1 Overview

The LM3492HC device integrates a boost converter and a two-channel current regulator to implement a highly efficient and cost effective LED driver for driving two individually dimmable LED strings with a maximum power of 15 W and an output voltage of up to 65 V. The boost converter provides power for the LED strings, and the current regulator controls the dimming of the LED strings individually. The device integrates an N-channel MOSFET switch and a two-channel current regulator to minimize the component count and solution size.

The two-channel current regulator responds quickly to allow a very high contrast ratio of 10000:1. The two channels dim individually. A digital command sent through the COMM pin disables Channel 1 of the current regulator. In this case, the DIM1 pin can serve only as a clock signal for the data flow of the COMM pin. The power dissipated by the current regulator is adaptively minimized by Dynamic Headroom Control to maximize efficiency.

When used in automotive LCD back-light panels, the device can operate efficiently for inputs as high as 65 V. Diagnostic functions including power good indication, over-temperature indication, output current overvoltage and undervoltage indications facilitate the interface of the device application circuit with external micro-processors (MCUs). The device does not latch off and continues to operate in the presence of the indications. Other useful features include thermal shutdown, VCC undervoltage lockout, and precision enable.

8.2 Functional Block Diagram

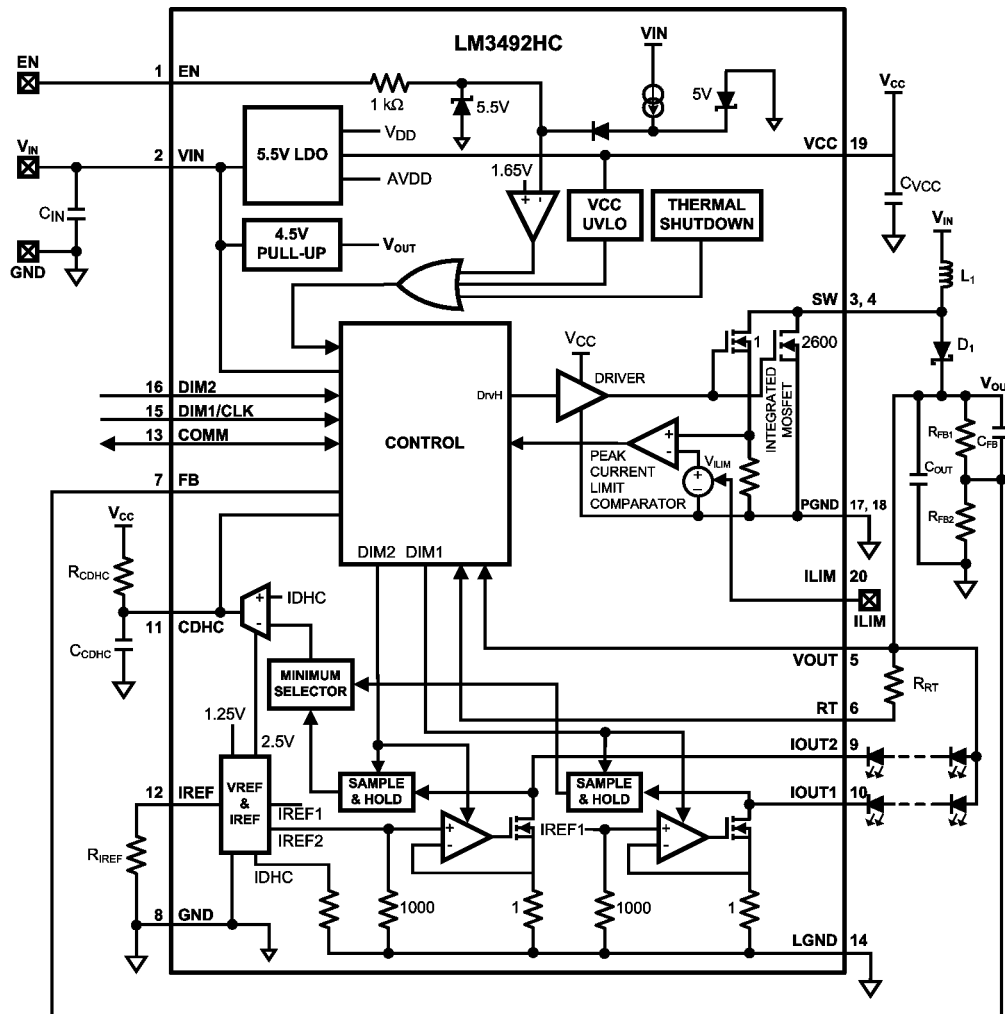

8.3 Feature Description

8.3.1 Switching Frequency

The boost converter of the LM3492HC device employs a projected-on-time (POT) control method to determine the on-time period of the MOSFET with respect to the input and output voltages and an external resistor R_{RT} . During the on-time period, the boost inductor charges up, and the output capacitor discharges to provide power to the output. A cycle-by-cycle current limit (which is 3.9 A typically and programmable by an external resistor) protects the MOSFET. After the on-time period, the MOSFET turns off and boost inductor discharges. The next on-time period starts when the voltage of the FB pin drops below a threshold which is determined by *dynamic headroom control* (DHC) and operates from 1.05 V to 2 V. DHC affects the threshold when either the DIM1 pin is high or the DIM2 pin is high.

During POT control operation, the boost converter maintains switching at a nearly constant frequency. During most operating conditions, the switching frequency depends on mainly the value of R_{RT} (Figure 19) but may see some variation with changes in input or output voltage. Also, POT control operation requires no compensation circuit and offers fast transient response of the output voltage. Applications that require very wide input voltage or very wide output voltage ranges may see some variation in the switching frequency as shown in Figure 20 and Figure 21. More switching frequency graphs can be found in the [Typical Characteristics](#) section.

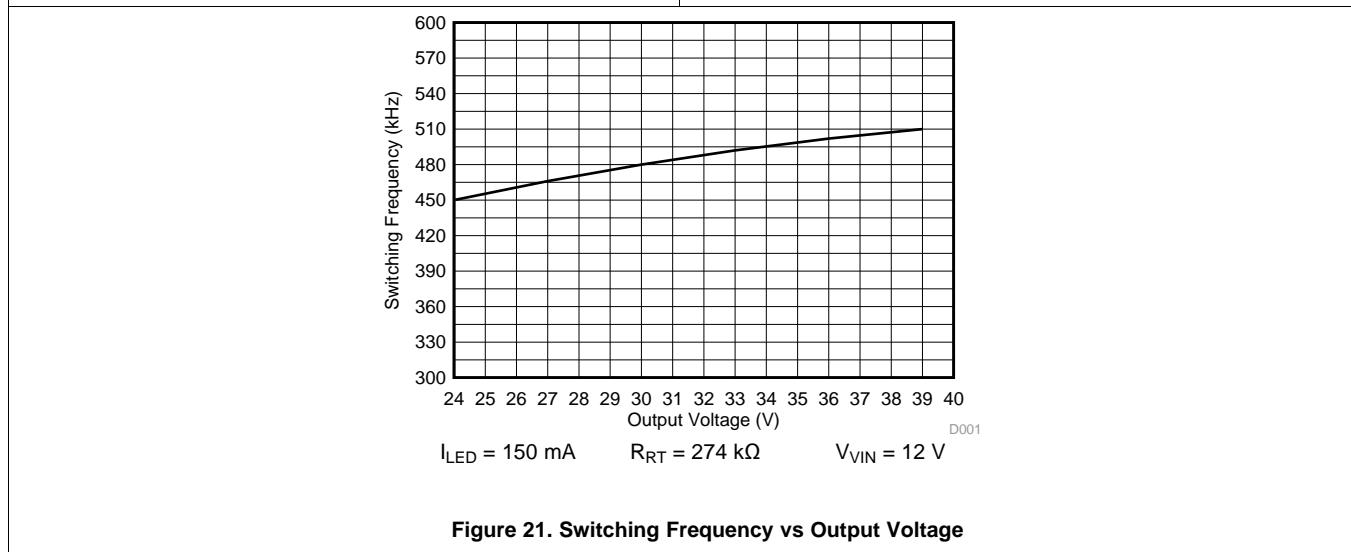
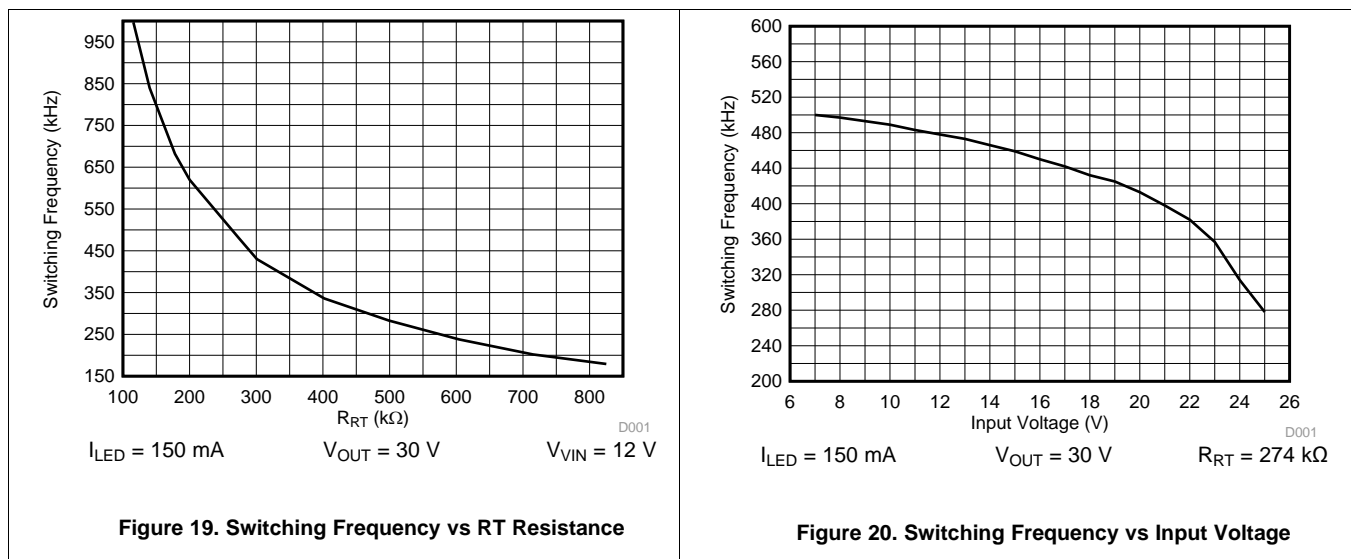

Feature Description (continued)

8.3.2 LDO Regulator

The LM3492HC device offers an integrated, 5.5-V, LDO regulator. For stability, connect an external capacitor C_{VCC} of more than 0.47- μ F between the VCC and GND pins. The current limit of the LDO is typically 30 mA. The LDO regulator can be used to pullup the open-drain COMM pin with an external resistor, and sources current to the ILIM pin to adjust the current limit of the integrated MOSFET. When the voltage on the VCC pin (V_{CC}) is higher than the undervoltage lockout (UVLO) threshold of 3.78 V, the device becomes enabled and the CDHC pin sources a current to charge up an external capacitor (C_{CDHC}) to provide a soft-start function.

8.3.3 Enable and Disable

To enable the LM3492HC device, the voltage on the EN pin (V_{EN}) must be higher than an enable threshold of typically 1.63 V. If the voltage on the EN pin (V_{EN}) is lower than 1.43 V, the device shuts down. In this case, the LDO regulator turns off and the CDHC pin becomes internally grounded. The EN pin internally pulls up. After enable, a 40- μ A current source pulls up the EN pin. If the EN pin is connected to low such that the device is shutdown, the pullup current is reduced to 2 μ A. These advantages allow the device to effectively avoid false disabling by noise during operation, and minimize power consumption during shutdown. The enable threshold is so precise that it can support a UVLO function for the input voltage as shown in Figure 22. The input voltage can be connected to the EN pin through a resistor divider consisting of R_{EN1} and R_{EN2} . This circuitry ensures that the device operates after the input voltage reaches a minimum require value $V_{IN(EN)}$, as shown in Equation 1.

$$V_{IN(EN)} = 1.63 V(1 + R_{EN1}/R_{EN2}) \quad (1)$$

To maintain the V_{EN} level below the absolute maximum specification, place a Zener diode (D_{EN}) between the EN pin and GND pins.

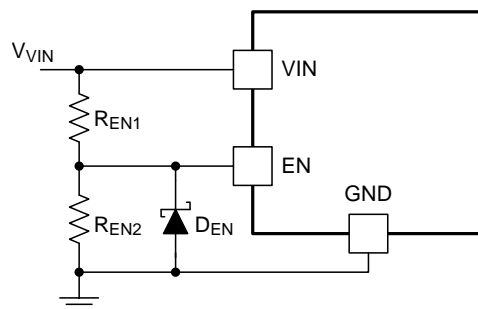

Figure 22. Input Voltage UVLO Implemented by Precision Enable

After the EN pin is pulled low, the device performs the following functions:

- resets IOUV overvoltage and undervoltage indications and the corresponding COMM bit pattern
- resumes the switching frequency tuning to the normal frequency
- resumes channel 1 of the current regulator if it is disabled

Pulling the EN pin low for a short period of approximately 200 ns achieves these same functions with little or no effect on the operation of the boost converter and the current regulator.

8.3.4 Current Limit

The current limit (I_{CL}) of the integrated MOSFET of the LM3492HC device provides a cycle-by-cycle current limit for protection. This limit can be decreased by injecting a small signal current, I_{ILIM} into the ILIM pin. The relationship between I_{CL} and I_{ILIM} is described in Equation 2.

$$I_{CL} = I_{CL(max)} - 4290 \times I_{ILIM}$$

where

- $I_{CL(max)}$ is the maximum current limit (3.9 A typical) (2)

As shown in Figure 23, create current limit functionality by connecting a resistor (R_{ILIM}) between the VCC pin and the ILIM pin. The typical voltage on the ILIM pin is 0.7 V. To obtain the maximum current limit, connect the ILIM pin to ground.

Feature Description (continued)

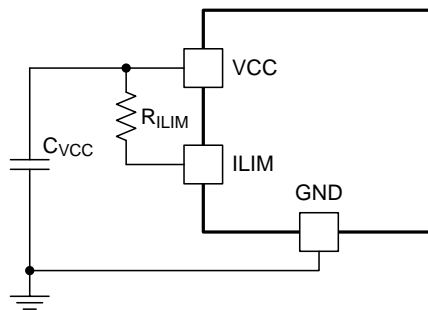

Figure 23. Programmable Current Limit

8.3.5 Thermal Protection

An internal thermal shutdown circuit provides thermal protection. The circuit activates at 165°C (typically) to disable the LM3492HC device. In this case, the LDO regulator turns off and the CDHC pin becomes internally grounded. Thermal protection helps prevent catastrophic failures from accidental device overheating. When the junction temperature of the device drops below 145°C (typical hysteresis = 20°C), the device resumes normal operation.

8.3.6 Dynamic Headroom Control, Over-Ride, and Soft-Start

The LM3492HC device uses dynamic headroom control (DHC) to adjust the output voltage (V_{OUT}) of the boost converter to reduce the power loss of the current regulator and thereby maximize efficiency. To understand this control function, consider $V_{LED,n}$ the forward voltage of an LED string connecting to the IOUT n pin and $V_{IOUT,n}$ as the voltage of the IOUT n pin (where n is 1, 2 for channels 1, 2 of the current regulator). $V_{LED,n}$ normally and gradually decreases (in terms of minutes) as a result of the rise of the LED die temperature during operation. The DHC adjusts the output voltage (V_{OUT}) by adjusting a threshold that is reflected in the voltage of the FB pin with reference to $V_{IOUT,n}$, (the difference between V_{OUT} and $V_{LED,n}$). The capacitor C_{CDHC} sets the sensitivity of DHC, which affects the response time on adjusting V_{OUT} . If the capacitance value of C_{CDHC} is small, V_{OUT} is more sensitive to the variation of $V_{LED,n}$.

Override the DHC functionality by adding internal pullup resistance or external pullup resistance by connecting the CDHC and VCC pins with a resistor. Use a value of approximately 10 M Ω . In this case, the voltage of the CDHC pin rises above 2.5 V, and the voltage of the FB pin rises until the voltage reaches the overvoltage protection threshold. Because the pullup is weak, DHC override occurs only at a low contrast ratio (approximately < 1%).

The C_{CDHC} capacitor acts to control the soft-start functionality. During the start-up period, the voltage of the CDHC pin rises from 0 V to 2.25 V at a rate that depends on the value of the C_{CDHC} capacitor. This limitation ensures that the voltage of the FB pin (as well as the output voltage) ramps up in a controlled manner, and effectively implements a soft-start function.

An internal switch grounds the CDHC pin during any of the following cases:

- V_{VCC} is below the VCC UVLO threshold
- a thermal shutdown occurs
- the EN pin is pulled low

The CDHC pin cannot be connected to the ground externally.

8.3.7 Current Regulator

The LM3492HC device integrates a two-channel current regulator for controlling the current of two LED strings. The two LED strings dim individually by applying individual dimming signals to the DIM1 and DIM2 pins for LED strings 1 and 2, which are connected from the VOUT pin to the IOUT1 and IOUT2 pins. The device pulls the DIM1 and DIM2 pins low internally. The lowest contrast ratio is 10000:1. The finest pulse width of the dimming signal for the DIM1 and DIM2 pins is 300 ns.

Feature Description (continued)

The device sets the current of an LED string (I_{LED}) from 50 mA to 250 mA by using an external resistor R_{IREF} connected between the IREF pin and ground. Figure 24 describes the relationship between I_{LED} and R_{IREF} . The two channels of the current regulator can work in parallel for only one LED string by connecting the IOUT1 and IOUT2 pins together to provide an LED current of up to 500 mA. In this case, connect the DIM1 and DIM2 pins together.

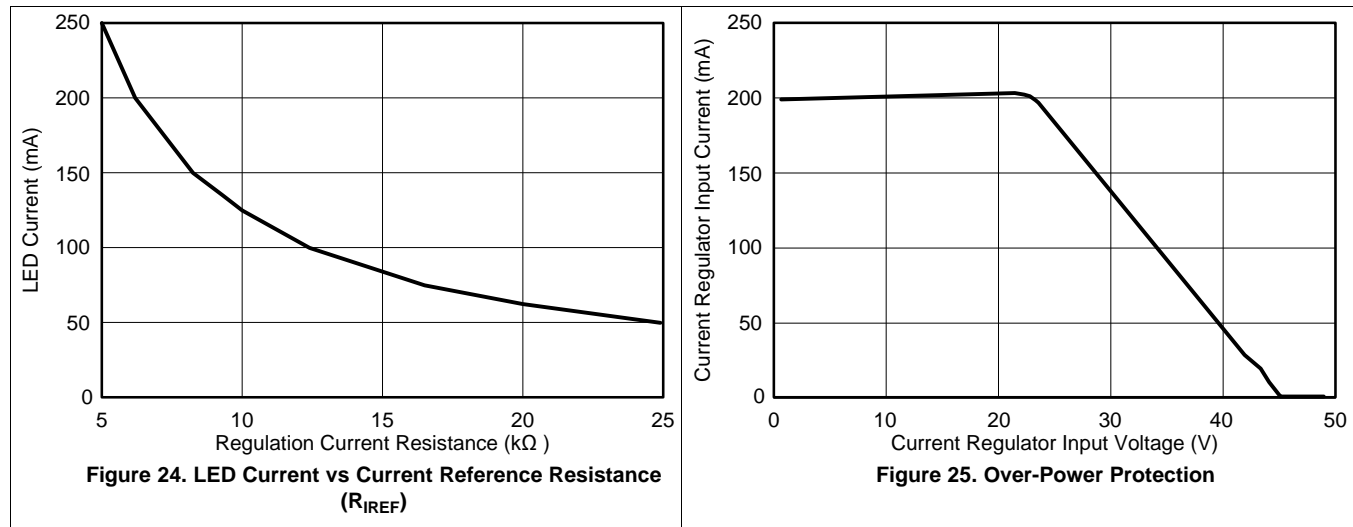

If the voltage on the IOUTn (n = 1, 2) pin is higher than 24 V when channel n is on, the regulated current of channel n reduces linearly if the voltage further increases (as shown in Figure 25). The regulated current of another channel is not affected. This over-power protection feature avoids damaging the current regulator owing to the shorting of many LEDs in one string.

8.3.8 Output Voltage Feedback

The device feeds the output voltage back to the FB pin through a feedback circuit consisting of R_{FB1} , R_{FB2} , and C_{FB} as shown in Figure 26. To assist the feedback functionality, maintain a value of 10 pF for C_{FB} . The DC component of the output voltage feedback uses R_{FB1} and R_{FB2} . The voltage of the FB pin V_{FB} can be adjusted by DHC. When V_{FB} reaches V_{FB-OVP} , the maximum output voltage of the boost converter $V_{OUT(max)}$ reaches its maximum, as shown in Equation 3.

$$V_{OUT(max)} = 2.88 \text{ V} (1 + R_{FB1} / R_{FB2}) \quad (3)$$

During DHC operation, maintain the output voltage at a nominal voltage but not the maximum. The nominal output voltage ($V_{OUT(nom)}$) is described in Equation 4.

$$V_{OUT(nom)} = \max(V_{LED,n} + V_{IOUT,n}), n = 1, 2$$

where

- $V_{LED,n}$ is the forward voltage of LED string n
- $V_{IOUT,n}$ is the voltage of the IOUTn pin, where n is 1, 2 for channels 1, 2 of the current regulator) (4)

The minimum value of $V_{IOUT,n}$ is approximately $5 \Omega \times I_{LED}$. The nominal voltage of the FB pin ($V_{FB(nom)}$) is recommended to be from 1.05 V to 2 V. Equation 5 describes the relation between $V_{OUT(max)}$, $V_{OUT(nom)}$, and $V_{FB(nom)}$:

$$V_{OUT(max)} = V_{OUT(nom)} \times 2.88 \text{ V} / V_{FB(nom)} \quad (5)$$

Feature Description (continued)

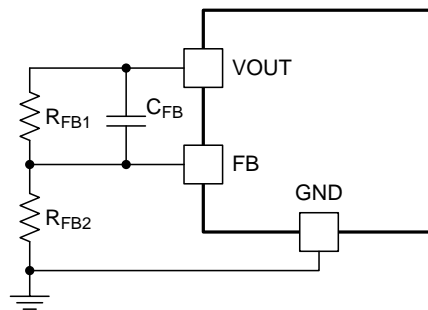

Figure 26. Output Voltage Feedback Circuit

8.3.9 Overvoltage Protection

When V_{FB} is higher than the FB pin overvoltage protection (OVP) threshold V_{FB-OVP} (typically 2.76 V and maximum 2.88 V), the on-period of the integrated MOSFET stop immediately, and the MOSFET keeps off until V_{FB} falls back below 2.545 V (typical hysteresis 0.215 V).

An alternative method to implement OVP is to directly monitor V_{OUT} instead of V_{FB} . An external circuit as shown in [Figure 27](#) is required. Current is injected to the ILIM pin to drive the LM3492HC device to the current limit mode once V_{OUT} is higher than the avalanche voltage of the Zener diode D_{OVP} plus 0.7 V, the typical voltage on the ILIM pin. In this case, the device imposes a maximum limit on V_{OUT} . However, at the maximum limit of V_{OUT} , V_{FB} must be higher than 2.25 V to avoid affecting the start-up of the device.

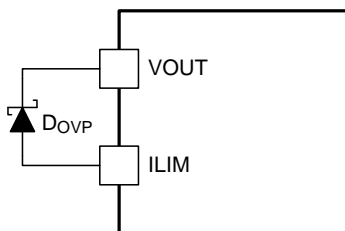

Figure 27. External OVP Circuit

8.3.10 Bidirectional Communication Pin

The COMM pin of the LM3492HC device is an open-drain bidirectional I/O pin for interfacing with an external MCU for the following functions:

- power-good indication
- overtemperature indication
- output current overvoltage and undervoltage indications
- switching frequency tuning
- channel 1 disabling

Except for the power good indication and the overtemperature alerts, all data flow through the COMM pin is serial and is latched by the falling edge of the signal applying to the DIM1 pin, even when channel 1 of the current regulator is disabled. If the DIM1 pin remains only low or only high, either by an external circuit or by allowing it to open and pull low internally, data does not flow. [Figure 28](#) and [Figure 29](#) show timing diagrams of reading and writing a bit from and to the device through the COMM pin.

Pull up the COMM pin by an MCU I/O pin, which has pullup capability, or an external resistor R_{COMM} connected to the VCC pin. Without this capability, the voltage of the COMM pin remains at zero. The rise time of the output signal of the COMM pin depends on the pullup power. If the rise time is long (R_{COMM} is too large or pullup power from the connecting MCU I/O pin is too weak), data may be ready after a longer duration after the falling edge. In this case, the design requires a longer delay between the falling edge latching and the (input or output) bit.

Feature Description (continued)

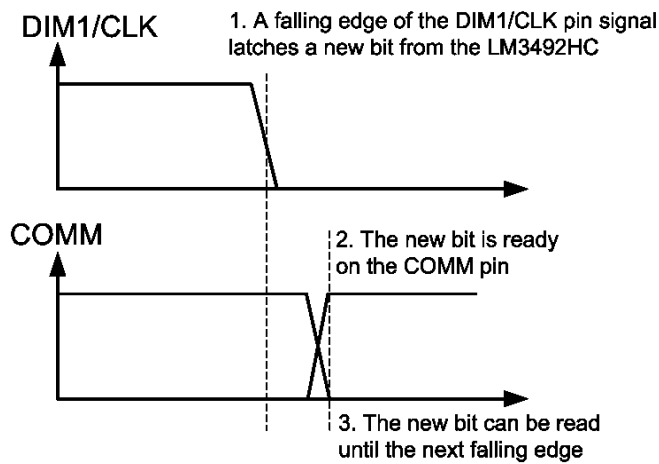

Figure 28. Read from the COMM Pin

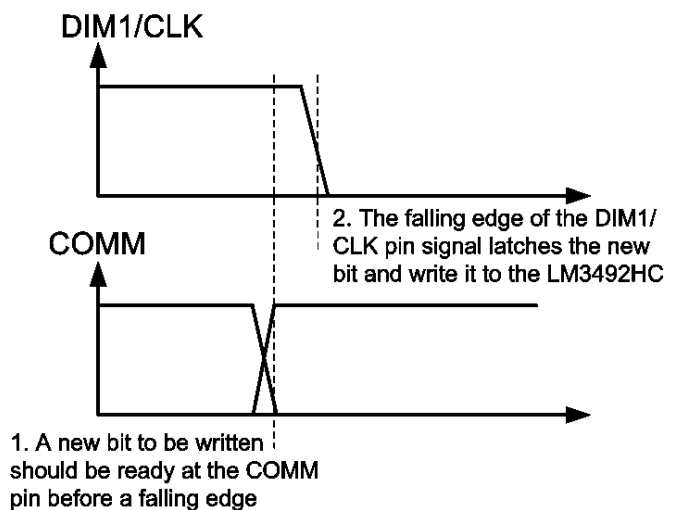

Figure 29. Write to the COMM Pin

8.3.10.1 Power-Good Indication

Upon start-up, the COMM pin reads low. The output voltage of the boost converter of the LM3492HC device rises until the voltage on the FB pin (V_{FB}) reaches 2.25 V, when the COMM pin reads high to indicate power-good. The power-good indication and the signal applied on the DIM1 pin are independent.

8.3.10.2 Overtemperature Indication

If the junction temperature of the LM3492HC device reaches 135°C, the COMM pin reads low, showing an overtemperature indication. The external MCU considers to either turn off or reduce the brightness of the LED strings to prevent overtemperature. The overtemperature indication and the signal applied on the DIM1 pin are independent. The COMM pin reads high if the junction temperature falls below 120°C. The device does not latch off and continues to operate in the presence of the overtemperature indication.

8.3.10.3 Output Current Undervoltage Indication

The LM3492HC device gives an IOUTn ($n = 1, 2$) undervoltage indication if the voltage of the IOUTn pin when DIMn is high is lower than its minimum required voltage which can regulate I_{LED} , and the voltage of the CDHC pin reaches its maximum. These conditions remain while the device applies 508 consecutive dimming signals on the DIMn pin. This means that the current of the LED string n does not reach the regulation value. In most cases, the IOUT undervoltage indication can be regarded as an open fault of the LED string n. A bit pattern (see Table 1) can be read from the COMM pin. The device does not latch off and continues to operate in the presence of the IOUT undervoltage indication.

8.3.10.4 Switching Frequency Tuning

After power good, the switching frequency (f_{SW}) of the LM3492HC device can be tuned down 20% or 40%, or resume normal by writing commands (refer to Table 2) to the COMM pin. This functionality helps avoid interfering some sensitive devices, for example radios, working nearby the device. Upon reset, the switching frequency (f_{SW}) of the device resumes normal by default. In the presence of an overtemperature indication or any COMM bit pattern, no command can be written to the device.

8.4 Device Functional Modes

There are no additional functional modes for this device.

8.5 Programming

8.5.1 Output Current Overvoltage Indication

The LM3492HC device gives an IOUT_n (n = 1, 2) overvoltage indication if the voltage of the IOUT_n pin when DIM_n is higher than a threshold of typically 6.5 V. These conditions remain while the device applies 508 consecutive dimming signals on the DIM_n pin. The IOUT overvoltage indication can be regarded as a short fault of the LED string n except the following two cases:

- powering up the device at a very low dimming ratio such that V_{OUT} maintains at a maximum and DHC is not fast enough to reduce V_{OUT}
- during DHC override condition, a bit pattern (see [Table 1](#)) can be read from the COMM pin

The device does not latch off and continues to operate in the presence of the IOUT overvoltage indication.

Table 1. COMM Indication Bit Patterns

| CONDITION | PIN | BIT PATTERN |
|--------------|-------|-------------|
| Overvoltage | IOUT1 | 0001 |
| | IOUT2 | 0011 |
| Undervoltage | IOUT1 | 0101 |
| | IOUT2 | 0111 |

8.5.2 COMM Pin Bit Pattern

[Table 1](#) summarizes all COMM bit patterns of output current overvoltage and undervoltage indications. An existing COMM bit pattern is cleared if one of the following condition occurs:

- the LM3492HC device is shutdown
- the LM3492HC device is disabled by pulling the EN pin low
- the overtemperature indication is appearing

Apply the clock signal on both DIM1 and DIM2 pins when the COMM bit pattern is read by an external MCU. Before reading the COMM bit pattern, pull the EN pin low for approximately 200 ns to reset the COMM bit pattern. This situation does not affect the operation of the boost converter and the current regulator. After EN is reset, if the IOUT overvoltage or undervoltage condition lasts for 508 consecutive clock cycles, the COMM pin sends the COMM bit pattern for the MCU to read.

In case of overtemperature, the device pulls the COMM pin low to give an overtemperature indication overriding any other pattern. After the overtemperature indication disappears, the COMM bit pattern appears before the over-temperature indication appears again.

8.5.3 Channel 1 Disable

After a power good verification, channel 1 of the current regulator can be disabled by writing a command (see [Table 2](#)) to the COMM pin. If LED string 1 is malfunctioning, channel 1 can be disabled and the signal applied on the DIM1 pin can serve as only a clock signal for the data flow of the COMM pin. Channel 1 is by default enabled after reset. If the overtemperature indication or any COMM bit pattern has already presented, no command can be written to the LM3492HC device.

Table 2. Channel Control Commands

| COMMAND | BIT PATTERN |
|----------------------------------|---------------------|
| f _{SW} resume normal | 1111 0111 0111 0111 |
| f _{SW} tune down by 20% | 1111 0001 0001 0001 |
| f _{SW} tune down by 40% | 1111 0011 0011 0011 |
| Channel 1 disable | 1111 0101 0101 0101 |

9 Application and Implementation

NOTE

Information in the following applications sections is not part of the TI component specification, and TI does not warrant its accuracy or completeness. TI's customers are responsible for determining suitability of components for their purposes. Customers should validate and test their design implementation to confirm system functionality.

9.1 Application Information

The LM3429HC/-Q1 device is ideal for automotive and marine GPS display and applications that require a high contrast ratio.

9.2 Typical Application

The following procedures are to design an LED driver using the LM3492HC/-Q1 device.

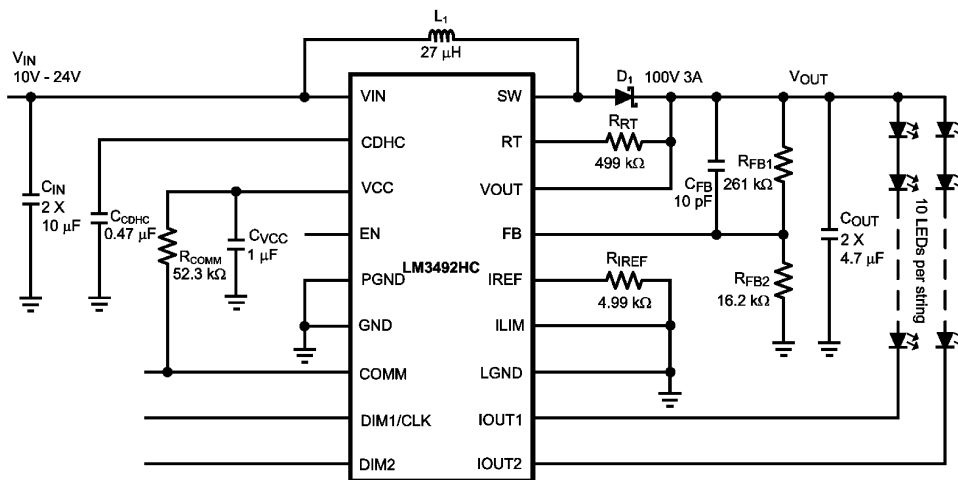

Figure 30. Typical Application Schematic

9.2.1 Design Requirements

The following procedures are to design an LED driver using the LM3492HC device with an input voltage ranged from 10 V to 24 V, and two LED strings consists of 10 LEDs each with a forward voltage of 3 V for each LED when running at 250 mA. The output power is 15 W. The switching frequency f_{SW} is designed to be 300 kHz.

9.2.2 Detailed Design Procedure

9.2.2.1 R_{FB1} , R_{FB2} , and C_{FB}

The nominal voltage of the LED string with 10 LEDs is 30 V, and the minimum voltage of the IOUTn pin ($n = 1, 2$) is 1.25 V when I_{LED} is 250 mA. As a result, $V_{OUT(nom)}$ is 31.25 V. Design $V_{OUT(max)}$ to be 50 V. From Equation 5, $V_{FB(nom)}$ is approximately 1.8 V, which falls in the recommended operation range from 1.05 V to 2 V. Also, design R_{FB2} to be 16.2 kΩ. From Equation 3, R_{FB1} is calculated to be 265.1 kΩ, and a standard resistor value of 261 kΩ is selected. C_{FB} is selected to be 10 pF as recommended.

9.2.2.2 L_1

The main parameter affected by the inductor is the peak to peak inductor current ripple (I_{LR}). To maintain a continuous conduction mode (CCM) operation, ensure that the average inductor current I_{L1} is larger than half of I_{LR} . For a boost converter, I_{L1} equals to the input current I_{IN} . Hence,

$$I_{IN} = (V_{OUT(nom)} \times 2 \times I_{LED}) / V_{IN} \quad (6)$$

Also,

Typical Application (continued)

$$t_{on} = (1 - V_{IN}/V_{OUT}) / f_{SW} \quad (7)$$

$$L_1 = (V_{IN} \times t_{on}) / 2I_{IN} \quad (8)$$

If V_{IN} is maximum, which is 24 V in this example, and only one LED string is turned on (because the two channels of the LM3492HC device are individually dimmable), I_{IN} is minimum. From Equation 6 to Equation 8, it can be calculated that $I_{IN(MIN)}$, t_{on} , and L_1 are 0.326 A, 0.77 μ s, and 28.5 μ H. However,, from Equation 6, I_{IN} is maximum when V_{IN} is minimum, which is 10 V in this example, and the two LED strings are turned on together. Hence $I_{IN(max)}$ is 1.56 A. Then, I_{LR} is

$$I_{LR} = (V_{IN} \times t_{on}) / L_1 \quad (9)$$

From Equation 7, t_{on} is 2.27 μ s. From (9), I_{LR} is 0.80 A. The steady-state peak inductor current $I_{L1(PEAK)}$ is

$$I_{L1(PEAK)} = I_{L1} + I_{LR} / 2 \quad (10)$$

As a result, $I_{L1(PEAK)}$ is 1.96 A. A standard value of 27 μ H is selected for L_1 , and its saturation current is larger than 1.96 A.

9.2.2.3 D_1

The selection of the boost diode D_1 depends on two factors. The first factor is the reverse voltage, which equals to V_{OUT} for a boost converter. The second factor is the peak diode current at the steady state, which equals to the peak inductor current as shown in Equation 10. In this example, a 100-V 3-A schottky diode is selected.

9.2.2.4 C_{IN} and C_{OUT}

The function of the input capacitor C_{IN} and the output capacitor C_{OUT} is to reduce the input and output voltage ripples. Experimentation is usually necessary to determine their value. The rated DC voltage of capacitors used should be higher than the maximum DC voltage applied. Owing to the concern of product lifetime, TI recommends ceramic capacitors. But ceramic capacitors with high rated DC voltage and high capacitance are rare in general. Multiple capacitors connecting in parallel can be used for C_{IN} and C_{OUT} . In this example, two 10- μ F ceramic capacitor are used for C_{IN} , and two 2.2- μ F ceramic capacitor are used for C_{OUT} .

9.2.2.5 C_{VCC}

The capacitor on the VCC pin provides noise filtering and stabilizes the LDO regulator. It also prevents false triggering of the VCC UVLO. C_{VCC} is recommended to be a 1- μ F, good quality and low ESR ceramic capacitor.

9.2.2.6 C_{CDHC}

The capacitor at the CDHC pin not only affects the sensitivity of the DHC but also determines the soft-start time t_{SS} , the time for the output voltage to rise until power good. t_{SS} is determined from the following equation:

$$t_{SS} = \frac{C_{CDHC} \times 2.25V}{120 \mu A} \quad (11)$$

In this example, C_{CDHC} is recommended to be a 0.47- μ F good quality and low ESR ceramic capacitor.

9.2.2.7 R_{RT} and R_{IREF}

The resistors R_{RT} and R_{IREF} set the switching frequency f_{SW} of the boost converter and the LED current I_{LED} respectively. From Figure 19, if f_{SW} is 300 kHz, R_{RT} is selected to be 442 k Ω . From Figure 24, if I_{LED} is 250 mA, R_{IREF} is selected to be 4.99 k Ω .

9.2.2.8 R_{COMM}

Because the COMM pin is open drain, a resistor R_{COMM} of 52.3 k Ω is used to connect the VCC and COMM pins to act as a pullup function.

Typical Application (continued)

9.2.3 Application Curve

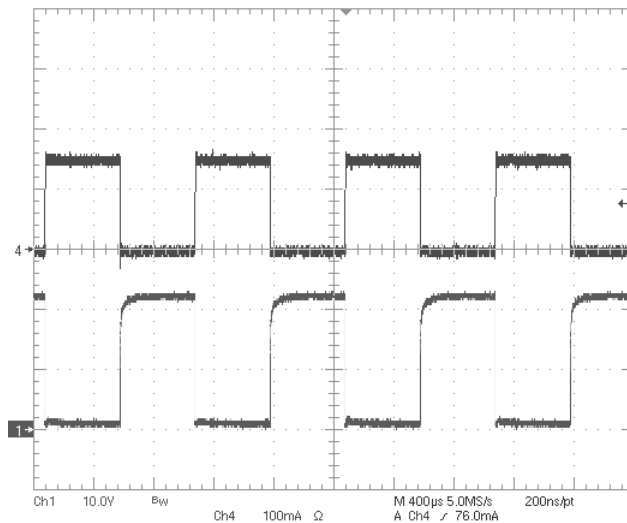

$I_{LED} = 150 \text{ mA}$ $V_{OUT} = 30 \text{ V}$ $V_{VIN} = 12 \text{ V}$
 Dimming frequency = 1 kHz Trace 1 = V_{IOUT1} Trace 4 = channel 1 LED

Figure 31. PWM Dimming

10 Power Supply Recommendations

Use a DC output power supply with a maximum output voltage capability greater than the maximum input voltage for the application. The current rating of the supply should be greater than the maximum input current required by the application.

11 Layout

11.1 Layout Guidelines

The layout of the printed-circuit-board is critical to optimize the performance of the LM3492HC device application circuit. In general, external components should be placed as close to the device and each other as possible to make copper traces short and direct. In particular, components of the boost converter C_{IN} , L_1 , D_1 , C_{OUT} , and the LM3492HC device should be closed. Also, the output feedback capacitor C_{FB} should be closed to the output capacitor C_{OUT} . The ground plane connecting the GND, PGND, and LGND pins and the exposed pad of the device and the ground connection of the C_{IN} and C_{OUT} should be placed on the same copper layer.

Good heat dissipation helps optimize the performance of the device. The ground plane should be used to connect the exposed pad of the device, which is internally connected to the device die substrate. The area of the ground plane should be extended as much as possible on the same copper layer around the device. Using numerous vias beneath the exposed pad to dissipate heat of the device to another copper layer is also a good practice.

11.2 Layout Example

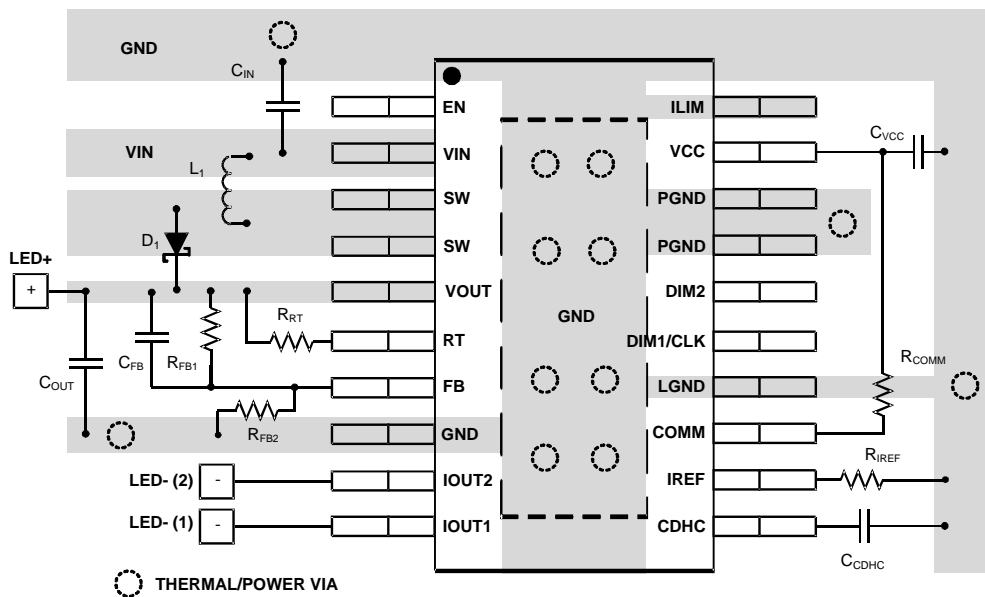

Figure 32. Layout Recommendation

12 Device and Documentation Support

12.1 Related Links

[Table 3](#) lists quick access links. Categories include technical documents, support and community resources, tools and software, and quick access to sample or buy.

Table 3. Related Links

| PARTS | PRODUCT FOLDER | SAMPLE & BUY | TECHNICAL DOCUMENTS | TOOLS & SOFTWARE | SUPPORT & COMMUNITY |
|-------------|----------------------------|----------------------------|----------------------------|----------------------------|----------------------------|
| LM3492HC | Click here | Click here | Click here | Click here | Click here |
| LM3492HC-Q1 | Click here | Click here | Click here | Click here | Click here |

12.2 Community Resources

The following links connect to TI community resources. Linked contents are provided "AS IS" by the respective contributors. They do not constitute TI specifications and do not necessarily reflect TI's views; see TI's [Terms of Use](#).

TI E2E™ Online Community *TI's Engineer-to-Engineer (E2E) Community*. Created to foster collaboration among engineers. At e2e.ti.com, you can ask questions, share knowledge, explore ideas and help solve problems with fellow engineers.

Design Support *TI's Design Support* Quickly find helpful E2E forums along with design support tools and contact information for technical support.

12.3 Trademarks

E2E is a trademark of Texas Instruments.
All other trademarks are the property of their respective owners.

12.4 Electrostatic Discharge Caution



These devices have limited built-in ESD protection. The leads should be shorted together or the device placed in conductive foam during storage or handling to prevent electrostatic damage to the MOS gates.

12.5 Glossary

[SLYZ022](#) — *TI Glossary*.

This glossary lists and explains terms, acronyms, and definitions.

13 Mechanical, Packaging, and Orderable Information

The following pages include mechanical, packaging, and orderable information. This information is the most current data available for the designated devices. This data is subject to change without notice and revision of this document. For browser-based versions of this data sheet, refer to the left-hand navigation.

PACKAGING INFORMATION

| Orderable Device | Status (1) | Package Type | Package Drawing | Pins | Package Qty | Eco Plan (2) | Lead/Ball Finish (6) | MSL Peak Temp (3) | Op Temp (°C) | Device Marking (4/5) | Samples |
|-------------------|---------------|--------------|-----------------|------|-------------|-------------------------|-------------------------|----------------------|--------------|-------------------------|-------------------------|
| LM3492HCMH/NOPB | ACTIVE | HTSSOP | PWP | 20 | 73 | Green (RoHS & no Sb/Br) | CU SN | Level-1-260C-UNLIM | -40 to 125 | LM3492 HCMH | Samples |
| LM3492HCMHX/NOPB | ACTIVE | HTSSOP | PWP | 20 | 2500 | Green (RoHS & no Sb/Br) | CU SN | Level-1-260C-UNLIM | -40 to 125 | LM3492 HCMH | Samples |
| LM3492HCQMH/NOPB | ACTIVE | HTSSOP | PWP | 20 | 73 | Green (RoHS & no Sb/Br) | CU SN | Level-1-260C-UNLIM | -40 to 125 | LM3492 HCQMH | Samples |
| LM3492HCQMHX/NOPB | ACTIVE | HTSSOP | PWP | 20 | 2500 | Green (RoHS & no Sb/Br) | CU SN | Level-1-260C-UNLIM | -40 to 125 | LM3492 HCQMH | Samples |

(1) The marketing status values are defined as follows:

ACTIVE: Product device recommended for new designs.

LIFEBUY: TI has announced that the device will be discontinued, and a lifetime-buy period is in effect.

NRND: Not recommended for new designs. Device is in production to support existing customers, but TI does not recommend using this part in a new design.

PREVIEW: Device has been announced but is not in production. Samples may or may not be available.

OBSOLETE: TI has discontinued the production of the device.

(2) Eco Plan - The planned eco-friendly classification: Pb-Free (RoHS), Pb-Free (RoHS Exempt), or Green (RoHS & no Sb/Br) - please check <http://www.ti.com/productcontent> for the latest availability information and additional product content details.

TBD: The Pb-Free/Green conversion plan has not been defined.

Pb-Free (RoHS): TI's terms "Lead-Free" or "Pb-Free" mean semiconductor products that are compatible with the current RoHS requirements for all 6 substances, including the requirement that lead not exceed 0.1% by weight in homogeneous materials. Where designed to be soldered at high temperatures, TI Pb-Free products are suitable for use in specified lead-free processes.

Pb-Free (RoHS Exempt): This component has a RoHS exemption for either 1) lead-based flip-chip solder bumps used between the die and package, or 2) lead-based die adhesive used between the die and leadframe. The component is otherwise considered Pb-Free (RoHS compatible) as defined above.

Green (RoHS & no Sb/Br): TI defines "Green" to mean Pb-Free (RoHS compatible), and free of Bromine (Br) and Antimony (Sb) based flame retardants (Br or Sb do not exceed 0.1% by weight in homogeneous material)

(3) MSL, Peak Temp. - The Moisture Sensitivity Level rating according to the JEDEC industry standard classifications, and peak solder temperature.

(4) There may be additional marking, which relates to the logo, the lot trace code information, or the environmental category on the device.

(5) Multiple Device Markings will be inside parentheses. Only one Device Marking contained in parentheses and separated by a "~" will appear on a device. If a line is indented then it is a continuation of the previous line and the two combined represent the entire Device Marking for that device.

(6) Lead/Ball Finish - Orderable Devices may have multiple material finish options. Finish options are separated by a vertical ruled line. Lead/Ball Finish values may wrap to two lines if the finish value exceeds the maximum column width.

Important Information and Disclaimer: The information provided on this page represents TI's knowledge and belief as of the date that it is provided. TI bases its knowledge and belief on information provided by third parties, and makes no representation or warranty as to the accuracy of such information. Efforts are underway to better integrate information from third parties. TI has taken and continues to take reasonable steps to provide representative and accurate information but may not have conducted destructive testing or chemical analysis on incoming materials and chemicals. TI and TI suppliers consider certain information to be proprietary, and thus CAS numbers and other limited information may not be available for release.

In no event shall TI's liability arising out of such information exceed the total purchase price of the TI part(s) at issue in this document sold by TI to Customer on an annual basis.

OTHER QUALIFIED VERSIONS OF LM3492HC, LM3492HC-Q1 :

- Catalog: [LM3492HC](#)
- Automotive: [LM3492HC-Q1](#)

NOTE: Qualified Version Definitions:

- Catalog - TI's standard catalog product
- Automotive - Q100 devices qualified for high-reliability automotive applications targeting zero defects

TAPE AND REEL INFORMATION

QUADRANT ASSIGNMENTS FOR PIN 1 ORIENTATION IN TAPE

*All dimensions are nominal

| Device | Package Type | Package Drawing | Pins | SPQ | Reel Diameter (mm) | Reel Width W1 (mm) | A0 (mm) | B0 (mm) | K0 (mm) | P1 (mm) | W (mm) | Pin1 Quadrant |
|-------------------|--------------|-----------------|------|------|--------------------|--------------------|---------|---------|---------|---------|--------|---------------|
| LM3492HCMHX/NOPB | HTSSOP | PWP | 20 | 2500 | 330.0 | 16.4 | 6.95 | 7.1 | 1.6 | 8.0 | 16.0 | Q1 |
| LM3492HCQMHX/NOPB | HTSSOP | PWP | 20 | 2500 | 330.0 | 16.4 | 6.95 | 7.1 | 1.6 | 8.0 | 16.0 | Q1 |

TAPE AND REEL BOX DIMENSIONS

*All dimensions are nominal

| Device | Package Type | Package Drawing | Pins | SPQ | Length (mm) | Width (mm) | Height (mm) |
|-------------------|--------------|-----------------|------|------|-------------|------------|-------------|
| LM3492HCMHX/NOPB | HTSSOP | PWP | 20 | 2500 | 367.0 | 367.0 | 35.0 |
| LM3492HCQMHX/NOPB | HTSSOP | PWP | 20 | 2500 | 367.0 | 367.0 | 35.0 |

IMPORTANT NOTICE AND DISCLAIMER

TI PROVIDES TECHNICAL AND RELIABILITY DATA (INCLUDING DATASHEETS), DESIGN RESOURCES (INCLUDING REFERENCE DESIGNS), APPLICATION OR OTHER DESIGN ADVICE, WEB TOOLS, SAFETY INFORMATION, AND OTHER RESOURCES "AS IS" AND WITH ALL FAULTS, AND DISCLAIMS ALL WARRANTIES, EXPRESS AND IMPLIED, INCLUDING WITHOUT LIMITATION ANY IMPLIED WARRANTIES OF MERCHANTABILITY, FITNESS FOR A PARTICULAR PURPOSE OR NON-INFRINGEMENT OF THIRD PARTY INTELLECTUAL PROPERTY RIGHTS.

These resources are intended for skilled developers designing with TI products. You are solely responsible for (1) selecting the appropriate TI products for your application, (2) designing, validating and testing your application, and (3) ensuring your application meets applicable standards, and any other safety, security, or other requirements. These resources are subject to change without notice. TI grants you permission to use these resources only for development of an application that uses the TI products described in the resource. Other reproduction and display of these resources is prohibited. No license is granted to any other TI intellectual property right or to any third party intellectual property right. TI disclaims responsibility for, and you will fully indemnify TI and its representatives against, any claims, damages, costs, losses, and liabilities arising out of your use of these resources.

TI's products are provided subject to TI's Terms of Sale (www.ti.com/legal/termsofsale.html) or other applicable terms available either on ti.com or provided in conjunction with such TI products. TI's provision of these resources does not expand or otherwise alter TI's applicable warranties or warranty disclaimers for TI products.

Mailing Address: Texas Instruments, Post Office Box 655303, Dallas, Texas 75265
Copyright © 2019, Texas Instruments Incorporated

Looking for pricing, stock, or lifecycle information?

Click below to explore more details on WIN SOURCE:

 [View LM3492HCMHX/NOPB on WIN SOURCE](#)

 [Texas Instruments](#) Information

Optimize Your Supply Chain with WIN SOURCE Solutions

-  Global Sourcing Solution
-  Obsolete Management
-  Cost Control Management
-  Shortage Management
-  Alternative Solution
-  Excess Inventory Management