



THE DATASHEET OF MSP430F135IPAG



MSP430F14x, MSP430F14x1, MSP430F13x Mixed-Signal Microcontrollers

1 Device Overview

1.1 Features

- Low Supply Voltage Range, 1.8 V to 3.6 V
- Ultra-Low Power Consumption:
 - Active Mode: 280 μ A at 1 MHz, 2.2 V
 - Standby Mode: 1.6 μ A
 - Off Mode (RAM Retention): 0.1 μ A
- Five Power-Saving Modes
- Wakeup From Standby Mode in Less Than 6 μ s
- 16-Bit RISC Architecture, 125-ns Instruction Cycle Time
- 12-Bit Analog-to-Digital Converter (ADC) With Internal Reference, Sample-and-Hold, and Autoscan Feature
- 16-Bit Timer_B With Seven Capture/Compare-With-Shadow Registers
- 16-Bit Timer_A With Three Capture/Compare Registers
- On-Chip Comparator
- Serial Onboard Programming, No External Programming Voltage Needed, Programmable Code Protection by Security Fuse
- Serial Communication Interface (USART), Functions as Asynchronous UART or Synchronous SPI Interface
 - Two USARTs (USART0, USART1) On MSP430F14x and MSP430F14x1 Devices
 - One USART (USART0) On MSP430F13x Devices
- Family Members (Also See [Device Comparison](#))
 - MSP430F133
 - 8KB + 256 Bytes of Flash Memory, 256 Bytes of RAM
 - MSP430F135
 - 16KB + 256 Bytes of Flash Memory, 512 Bytes of RAM
 - MSP430F147, MSP430F1471
 - 32KB + 256 Bytes of Flash Memory, 1KB of RAM
 - MSP430F148, MSP430F1481
 - 48KB + 256 Bytes of Flash Memory, 2KB of RAM
 - MSP430F149, MSP430F1491
 - 60KB + 256 Bytes of Flash Memory, 2KB of RAM

1.2 Applications

- Sensor Systems
- Industrial Controls
- Hand-Held Meters

1.3 Description

The Texas Instruments MSP430™ family of ultra-low-power microcontrollers (MCUs) consist of several devices featuring different sets of peripherals targeted for various applications. The architecture, combined with five low-power modes is optimized to achieve extended battery life in portable measurement applications. The device features a powerful 16-bit RISC CPU, 16-bit registers, and constant generators that attribute to maximum code efficiency. The digitally controlled oscillator (DCO) allows wake-up from low-power modes to active mode in less than 6 μ s.

The MSP430F13x, MSP430F14x, and MSP430F14x1 MCUs support two built-in 16-bit timers, a fast 12-bit ADC on the MSP430F13x and the MSP430F14x devices, one USART on the MSP430F13x devices or two USARTs on the MSP430F14x and MSP430F14x1 devices, and 48 I/O pins. The hardware multiplier enhances the performance and offers a broad code and hardware-compatible family solution.

For complete module descriptions, see the [MSP430x1xx Family User's Guide](#).



Device Information⁽¹⁾

PART NUMBER	PACKAGE	BODY SIZE ⁽²⁾
MSP430F149IPM	LQFP (64)	10 mm x 10 mm
MSP430F149IPAG	TQFP (64)	10 mm x 10 mm
MSP430F1491IRTD	VQFN (64)	9 mm x 9 mm

(1) For the most current device, package, and ordering information, see the *Package Option Addendum* in Section 8, or see the TI website at www.ti.com.

(2) The sizes shown here are approximations. For the package dimensions with tolerances, see the *Mechanical Data* in Section 8.

1.4 Functional Block Diagrams

Figure 1-1 shows the functional block diagram for the MSP430F13x MCUs.

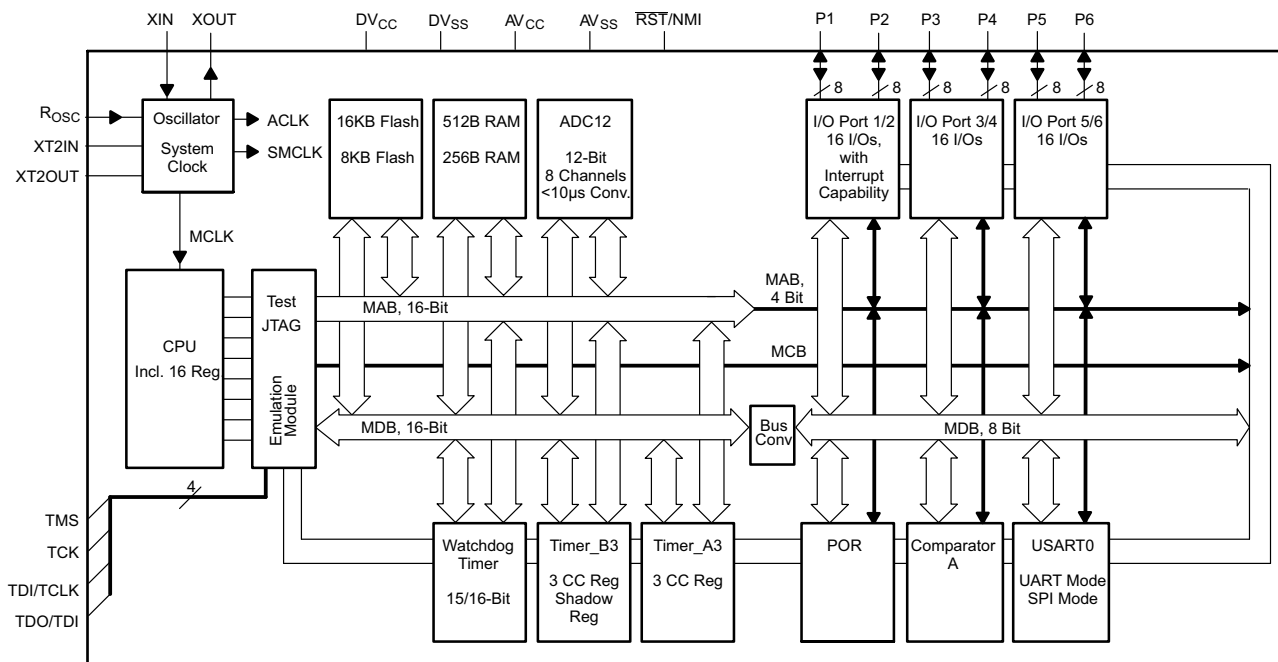

Figure 1-1. Functional Block Diagram, MSP430F13x

Figure 1-2 shows the functional block diagram for the MSP430F14x MCUs.

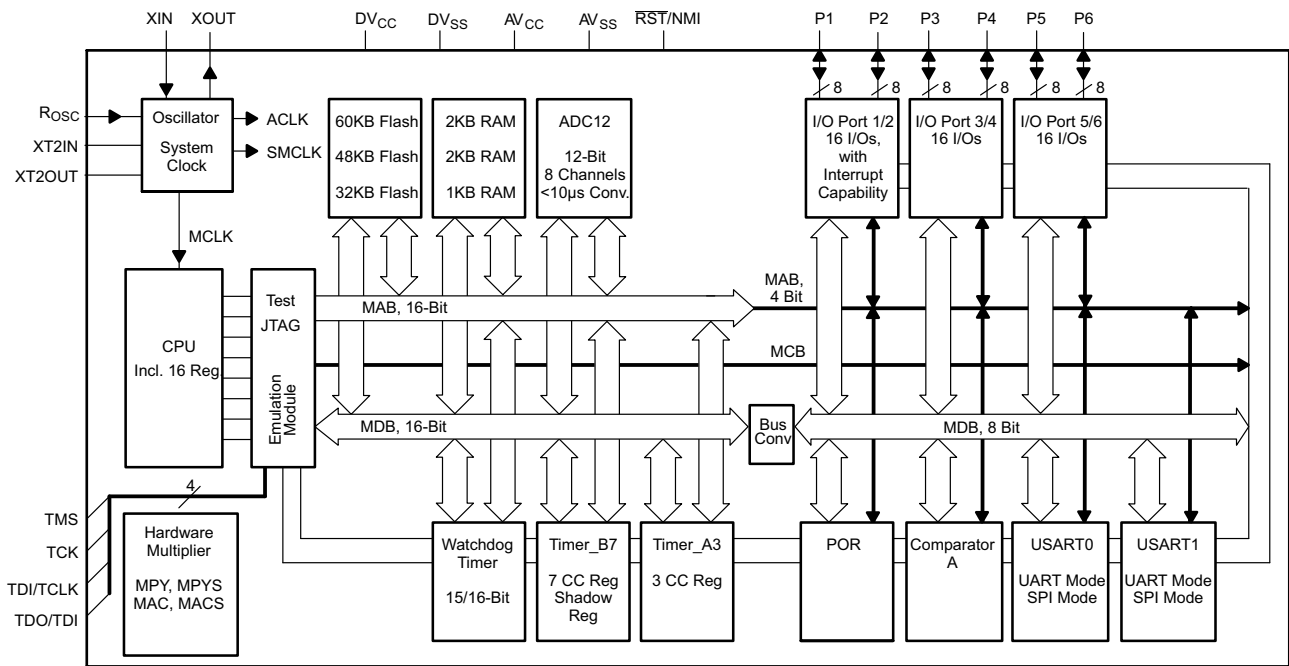

Figure 1-2. Functional Block Diagram, MSP430F14x

Figure 1-3 shows the functional block diagram for the MSP430F14x1 MCUs.

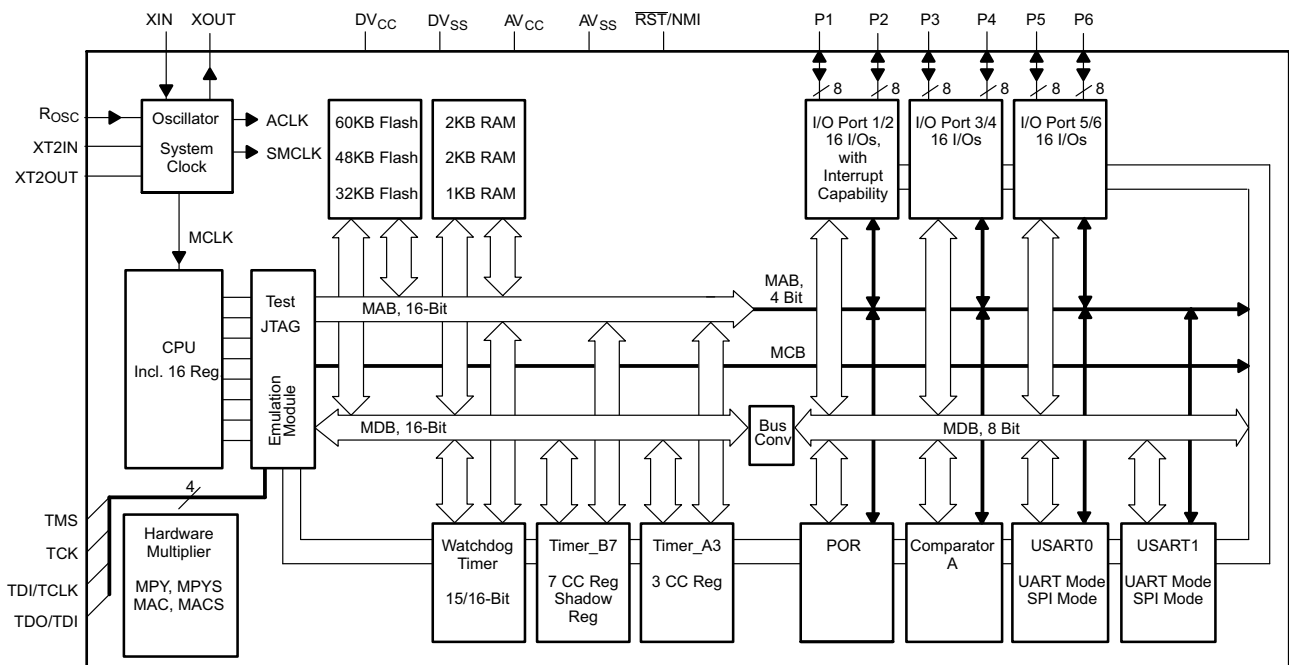

Figure 1-3. Functional Block Diagram, MSP430F14x1

Table of Contents

1	Device Overview	1	5.21	Crystal Oscillator, XT2	26
1.1	Features	1	5.22	USART0, USART1	26
1.2	Applications	1	5.23	12-Bit ADC, Power Supply and Input Range Conditions	27
1.3	Description	1	5.24	12-Bit ADC, External Reference	27
1.4	Functional Block Diagrams	2	5.25	12-Bit ADC, Built-In Reference	28
2	Revision History	5	5.26	12-Bit ADC, Timing Parameters	30
3	Device Comparison	6	5.27	12-Bit ADC, Linearity Parameters	30
3.1	Related Products	6	5.28	12-Bit ADC, Temperature Sensor and Built-In V_{MID}	31
4	Terminal Configuration and Functions	7	5.29	Flash Memory	31
4.1	Pin Diagrams	7	5.30	JTAG Interface	32
4.2	Signal Descriptions	10	5.31	JTAG Fuse	32
5	Specifications	16	6	Detailed Description	33
5.1	Absolute Maximum Ratings	16	6.1	CPU	33
5.2	ESD Ratings	16	6.2	Instruction set	34
5.3	Recommended Operating Conditions	16	6.3	Operating Modes	34
5.4	Supply Current Into AV_{CC} and DV_{CC} Excluding External Current	17	6.4	Interrupt Vector Addresses	35
5.5	Thermal Resistance Characteristics	18	6.5	Bootloader (BSL)	35
5.6	Schmitt-Trigger Inputs – Ports P1, P2, P3, P4, P5, and P6	18	6.6	JTAG Fuse Check Mode	36
5.7	Standard Inputs – \overline{RST}/NMI , JTAG (TCK, TMS, TDI/TCLK, TDO/TDI)	18	6.7	Memory	36
5.8	Inputs – Px.y, TAx, TBx	18	6.8	Peripherals	40
5.9	Leakage Current	19	6.9	Input/Output Diagrams	48
5.10	Outputs – Ports P1, P2, P3, P4, P5, and P6	19	7	Device and Documentation Support	59
5.11	Output Frequency	19	7.1	Getting Started and Next Steps	59
5.12	Typical Characteristics – Ports P1, P2, P3, P4, P5, and P6 Outputs	20	7.2	Device Nomenclature	59
5.13	Wake-up Time From LPM3	21	7.3	Tools and Software	61
5.14	RAM	21	7.4	Documentation Support	62
5.15	Comparator_A	21	7.5	Related Links	63
5.16	Typical Characteristics – Comparator_A	22	7.6	Community Resources	63
5.17	PUC and POR	23	7.7	Trademarks	63
5.18	DCO Frequency	24	7.8	Electrostatic Discharge Caution	64
5.19	DCO When Using R_{OSC}	25	7.9	Export Control Notice	64
5.20	Crystal Oscillator, LFXT1	26	7.10	Glossary	64
			8	Mechanical, Packaging, and Orderable Information	65

2 Revision History

NOTE: Page numbers for previous revisions may differ from page numbers in the current version.

Changes from February 12, 2009 to May 23, 2018	Page
• Document format and organization changes throughout	1
• Added Section 1.2, Applications	1
• Added Section 3, Device Comparison	6
• Added Section 5.2, ESD Ratings	16
• Removed note (2) with duplicate information from the $f_{L\text{FXT}1}$ parameter in Section 5.3, Recommended Operating Conditions	16
• Removed duplicate conditions "XTS = 0, SELM = 0 or 1" from the second row of Test Conditions on the $I_{(AM)}$ parameter in Section 5.4, Supply Current Into AV_{CC} and DV_{CC} Excluding External Current	17
• Added Section 5.5, Thermal Resistance Characteristics	18
• Removed ADC12DIV from the equation in the TYP value of the t_{CONVERT} parameter (because ADC12CLK is after division) in Section 5.26, 12-Bit ADC, Timing Parameters	30
• Changed all instances of <i>bootstrap loader</i> to <i>bootloader</i> throughout document.....	35
• Added Section 7, Device and Documentation Support	59

3 Device Comparison

Table 3-1 summarizes the features of the device variants in this data sheet.

Table 3-1. Device Comparison⁽¹⁾⁽²⁾

Device	Flash	SRAM	Timer_A ⁽³⁾	Timer_B ⁽⁴⁾	USART	COMP_A	ADC12 (Channels)	I/Os	Package
MSP430F149	60KB	2KB	3	7	2	1	8	48	64-pin PM 64-pin PAG 64-pin RTD
MSP430F1491	60KB	2KB	3	7	2	1	8	48	64-pin PM 64-pin RTD
MSP430F148	48KB	2KB	3	7	2	1	8	48	64-pin PM 64-pin PAG 64-pin RTD
MSP430F1481	48KB	2KB	3	7	2	1	8	48	64-pin PM 64-pin RTD
MSP430F147	32KB	1KB	3	7	2	1	8	48	64-pin PM 64-pin PAG 64-pin RTD
MSP430F1471	32KB	1KB	3	7	2	1	8	48	64-pin PM 64-pin RTD
MSP430F135	16KB	512 bytes	3	3	1	1	8	48	64-pin PM 64-pin PAG 64-pin RTD
MSP430F133	8KB	256 bytes	3	3	1	1	8	48	64-pin PM 64-pin PAG 64-pin RTD

- (1) For the most current package and ordering information, see the *Package Option Addendum* in [Section 8](#), or see the TI website at www.ti.com.
- (2) Package drawings, thermal data, and symbolization are available at www.ti.com/packaging.
- (3) Each number in the sequence represents an instantiation of Timer_A with its associated number of capture/compare registers and PWM output generators available. For example, a number sequence of 3, 5 would represent two instantiations of Timer_A, the first instantiation having 3 and the second instantiation having 5 capture/compare registers and PWM output generators, respectively.
- (4) Each number in the sequence represents an instantiation of Timer_B with its associated number of capture/compare registers and PWM output generators available. For example, a number sequence of 3, 5 would represent two instantiations of Timer_B, the first instantiation having 3 and the second instantiation having 5 capture/compare registers and PWM output generators, respectively.

3.1 Related Products

For information about other devices in this family of products or related products, see the following links.

TI 16-bit and 32-bit microcontrollers High-performance, low-power solutions to enable the autonomous future

Products for MSP430 ultra-low-power microcontrollers One platform. One ecosystem. Endless possibilities.

Products for other MSP430 microcontrollers MCUs for metrology, monitoring, system control, and communications

Companion Products for MSP430F149 Review products that are frequently purchased or used with this product.

Reference Designs The TI Designs Reference Design Library is a robust reference design library that spans analog, embedded processor, and connectivity. Created by TI experts to help you jump start your system design, all TI Designs include schematic or block diagrams, BOMs, and design files to speed your time to market.

4 Terminal Configuration and Functions

4.1 Pin Diagrams

Figure 4-1 shows the pinout for the MSP430F133 and MSP430F135 MCUs in the 64-pin PM, PAG, and RTD packages.

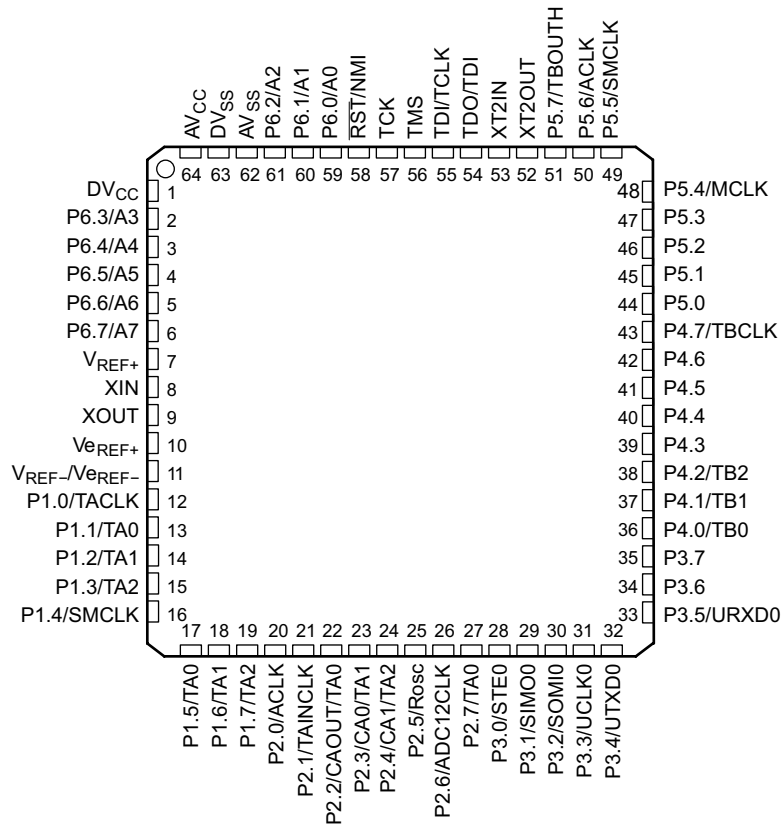

Figure 4-1. 64-Pin PM, PAG, or RTD Package (Top View) for MSP430F133 and MSP430F135

Figure 4-2 shows the pinout for the MSP430F147, MSP430F148, and MSP430F149 MCUs in the 64-pin PM, PAG, and RTD packages.

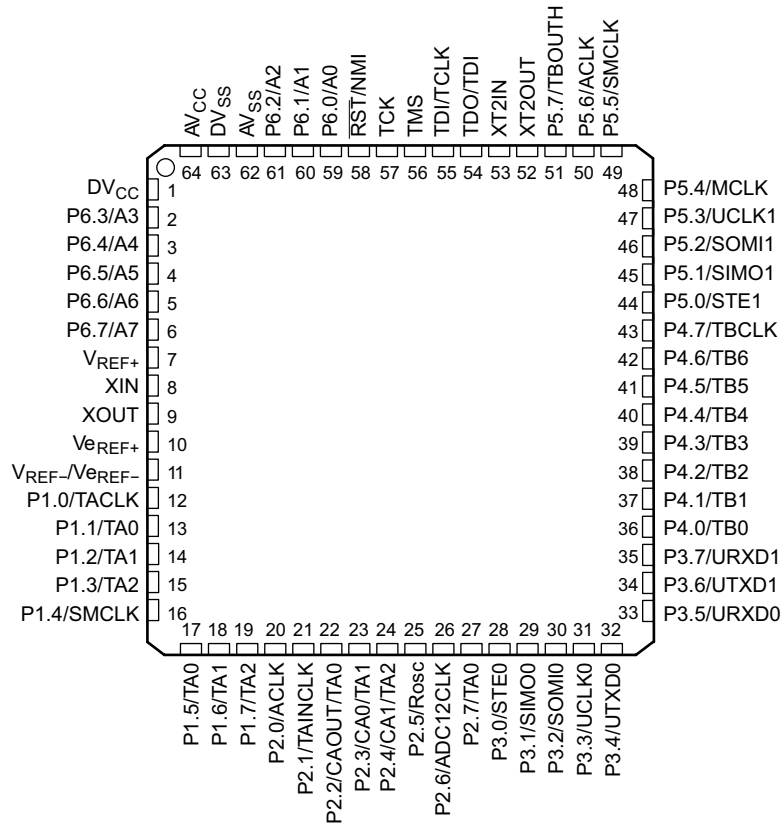

Figure 4-2. 64-Pin PM, PAG, or RTD Package (Top View) for MSP430F147, MSP430F148, and MSP430F149

Figure 4-3 shows the pinout for the MSP430F1471, MSP430F1481, and MSP430F1491 MCUs in the 64-pin PM and RTD packages.

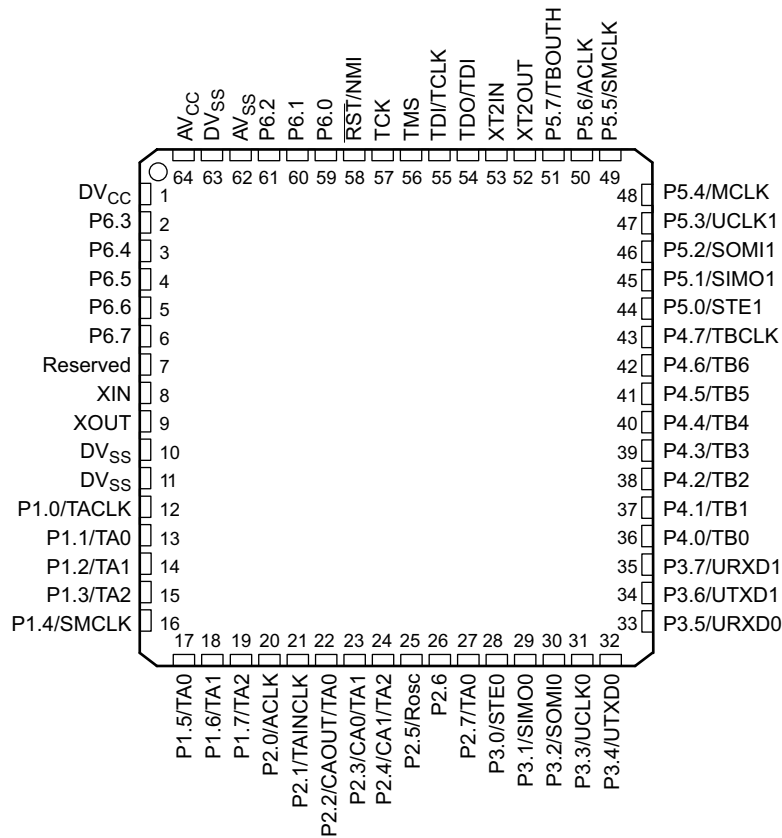

Figure 4-3. 64-Pin PM or RTD Package (Top View) for MSP430F1471, MSP430F1481, and MSP430F1491

4.2 Signal Descriptions

Table 4-1 describes the signals for the MSP430F13x and MSP430F14x MCUs. See Table 4-2 for the MSP430F14x1 signal descriptions.

Table 4-1. Signal Descriptions for MSP430F13x and MSP430F14x

SIGNAL NAME	PIN NO.	I/O	DESCRIPTION
AV _{CC}	64		Analog supply voltage, positive terminal. Supplies the analog portion of the ADC.
AV _{SS}	62		Analog supply voltage, negative terminal. Supplies the analog portion of the ADC.
DV _{CC}	1		Digital supply voltage, positive terminal. Supplies all digital parts.
DV _{SS}	63		Digital supply voltage, negative terminal. Supplies all digital parts.
P1.0/TACLK	12	I/O	General-purpose digital I/O pin Timer_A, clock signal TACLK input
P1.1/TA0	13	I/O	General-purpose digital I/O pin Timer_A, capture: CCI0A input, compare: Out0 output BSL transmit
P1.2/TA1	14	I/O	General-purpose digital I/O pin Timer_A, capture: CCI0A input, compare: Out0 output BSL transmit
P1.3/TA2	15	I/O	General-purpose digital I/O pin Timer_A, capture: CCI2A input, compare: Out2 output
P1.4/SMCLK	16	I/O	General-purpose digital I/O pin SMCLK signal output
P1.5/TA0	17	I/O	General-purpose digital I/O pin Timer_A, compare: Out0 output
P1.6/TA1	18	I/O	General-purpose digital I/O pin Timer_A, compare: Out1 output
P1.7/TA2	19	I/O	General-purpose digital I/O pin Timer_A, compare: Out2 output/
P2.0/ACLK	20	I/O	General-purpose digital I/O pin ACLK output
P2.1/TAINCLK	21	I/O	General-purpose digital I/O pin Timer_A, clock signal at INCLK
P2.2/CAOUT/TA0	22	I/O	General-purpose digital I/O pin Comparator_A output Timer_A, capture: CCI0B input BSL receive
P2.3/CA0/TA1	23	I/O	General-purpose digital I/O pin Timer_A, compare: Out1 output Comparator_A input
P2.4/CA1/TA2	24	I/O	General-purpose digital I/O pin Timer_A, compare: Out2 output Comparator_A input
P2.5/R _{osc}	25	I/O	General-purpose digital I/O pin input for external resistor defining the DCO nominal frequency
P2.6/ADC12CLK	26	I/O	General-purpose digital I/O pin Conversion clock for ADC
P2.7/TA0	27	I/O	General-purpose digital I/O pin Timer_A, compare: Out0 output
P3.0/STE0	28	I/O	General-purpose digital I/O pin Slave transmit enable for USART0 in SPI mode
P3.1/SIMO0	29	I/O	General-purpose digital I/O pin Slave in/master out of USART0 in SPI mode
P3.2/SOMI0	30	I/O	General-purpose digital I/O pin Slave out/master in of USART0 in SPI mode
P3.3/UCLK0	31	I/O	General-purpose digital I/O USART0 clock: external input in UART or SPI mode, output in SPI mode
P3.4/UTXD0	32	I/O	General-purpose digital I/O pin Transmit data out for USART0 in UART mode

Table 4-1. Signal Descriptions for MSP430F13x and MSP430F14x (continued)

SIGNAL NAME	PIN NO.	I/O	DESCRIPTION
P3.5/URXD0	33	I/O	General-purpose digital I/O pin Receive data in for USART0 in UART mode
P3.6/UTXD1 ⁽¹⁾	34	I/O	General-purpose digital I/O pin Transmit data out for USART1 in UART mode
P3.7/URXD1 ⁽¹⁾	35	I/O	General-purpose digital I/O pin Receive data in for USART1 in UART mode
P4.0/TB0	.36	I/O	General-purpose digital I/O pin Timer_B, capture: CCI0A or CCI0B input, compare: Out0 output
P4.1/TB1	37	I/O	General-purpose digital I/O pin Timer_B, capture: CCI1A or CCI1B input, compare: Out1 output
P4.2/TB2	38	I/O	General-purpose digital I/O pin Timer_B, capture: CCI2A or CCI2B input, compare: Out2 output
P4.3/TB3 ⁽¹⁾	39	I/O	General-purpose digital I/O pin Timer_B, capture: CCI3A or CCI3B input, compare: Out3 output
P4.4/TB4 ⁽¹⁾	40	I/O	General-purpose digital I/O pin Timer_B, capture: CCI4A or CCI4B input, compare: Out4 output
P4.5/TB5 ⁽¹⁾	41	I/O	General-purpose digital I/O pin Timer_B, capture: CCI5A or CCI5B input, compare: Out5 output
P4.6/TB6 ⁽¹⁾	42	I/O	General-purpose digital I/O pin Timer_B, capture: CCI6A or CCI6B input, compare: Out6 output
P4.7/TBCLK	43	I/O	General-purpose digital I/O pin Timer_B, clock signal TBCLK input
P5.0/STE1 ⁽¹⁾	44	I/O	General-purpose digital I/O pin Slave transmit enable for USART1 in SPI mode
P5.1/SIMO1 ⁽¹⁾	45	I/O	General-purpose digital I/O pin Slave in/master out of USART1 in SPI mode
P5.2/SOMI1 ⁽¹⁾	46	I/O	General-purpose digital I/O pin Slave out/master in of USART1 in SPI mode
P5.3/UCLK1 ⁽¹⁾	47	I/O	General-purpose digital I/O pin USART1 clock: external input in UART or SPI mode, output in SPI mode
P5.4/MCLK	48	I/O	General-purpose digital I/O pin Main system clock MCLK output
P5.5/SMCLK	49	I/O	General-purpose digital I/O pin Submain system clock SMCLK output
P5.6/ACLK	50	I/O	General-purpose digital I/O pin Auxiliary clock ACLK output
P5.7/TBOUTH	51	I/O	General-purpose digital I/O pin Switch all PWM digital output ports to high impedance for Timer_B7 (TB0 to TB6)
P6.0/A0	59	I/O	General-purpose digital I/O pin Analog input A0 for ADC
P6.1/A1	60	I/O	General-purpose digital I/O pin Analog input A1 for ADC
P6.2/A2	61	I/O	General-purpose digital I/O pin Analog input A2 for ADC
P6.3/A3	2	I/O	General-purpose digital I/O pin Analog input A3 for ADC
P6.4/A4	3	I/O	General-purpose digital I/O pin Analog input A4 for ADC
P6.5/A5	4	I/O	General-purpose digital I/O pin Analog input A5 for ADC
P6.6/A6	5	I/O	General-purpose digital I/O pin Analog input A6 for ADC
P6.7/A7	6	I/O	General-purpose digital I/O pin Analog input A7 for ADC

(1) MSP430F14x devices only

Table 4-1. Signal Descriptions for MSP430F13x and MSP430F14x (continued)

SIGNAL NAME	PIN NO.	I/O	DESCRIPTION
$\overline{\text{RST}}/\text{NMI}$	58	I	Reset input Nonmaskable interrupt input port Bootloader start
TCK	57	I	Test clock, the clock input port for device programming test and bootloader start
TDI/TCLK	55	I	Test data input or test clock input. The device protection fuse is connected to TDI/TCLK.
TDO/TDI	54	I/O	Test data output or programming data input
TMS	56	I	Test mode select, used as an input port for device programming and test
VeREF+	10	I	Input for an external reference voltage to the ADC
VREF+	7	O	Output of positive terminal of the reference voltage in the ADC
VREF-/-VeREF-	11	I	Negative terminal for the ADC reference voltage for both sources, the internal reference voltage or an external applied reference voltage
XIN	8	I	Input port for crystal oscillator XT1, standard or watch crystals can be connected
XOUT	9	O	Output terminal of crystal oscillator XT1
XT2IN	53	I	Input port for crystal oscillator XT2, only standard crystals can be connected
XT2OUT	52	O	Output terminal of crystal oscillator XT2
QFN Pad	NA	NA	QFN package pad, connect to DV _{SS}

Table 4-2 describes the signals for the MSP430F14x1 MCUs. See Table 4-1 for the MSP430F13x and MSP430F14x signal descriptions.

Table 4-2. Signal Descriptions for MSP430F14x1

SIGNAL NAME	PIN NO.	I/O	DESCRIPTION
AV _{CC}	64		Analog supply voltage positive terminal
AV _{SS}	62		Analog supply voltage negative terminal
DV _{CC}	1		Digital supply voltage, positive terminal. Supplies all digital parts.
DV _{SS}	63		Digital supply voltage, negative terminal. Supplies all digital parts.
P1.0/TACLK	12	I/O	General-purpose digital I/O pin Timer_A, clock signal TACLK input
P1.1/TA0	13	I/O	General-purpose digital I/O pin Timer_A, capture: CCI0A input, compare: Out0 output BSL transmit
P1.2/TA1	14	I/O	General-purpose digital I/O pin Timer_A, capture: CCI1A input, compare: Out1 output
P1.3/TA2	15	I/O	General-purpose digital I/O pin Timer_A, capture: CCI2A input, compare: Out2 output
P1.4/SMCLK	16	I/O	General-purpose digital I/O pin SMCLK signal output
P1.5/TA0	17	I/O	General-purpose digital I/O pin Timer_A, compare: Out0 output
P1.6/TA1	18	I/O	General-purpose digital I/O pin Timer_A, compare: Out1 output
P1.7/TA2	19	I/O	General-purpose digital I/O pin Timer_A, compare: Out2 output
P2.0/ACLK	20	I/O	General-purpose digital I/O pin ACLK output
P2.1/TAINCLK	21	I/O	General-purpose digital I/O pin Timer_A, clock signal at INCLK
P2.2/CAOUT/TA0	22	I/O	General-purpose digital I/O pin Timer_A, capture: CCI0B input Comparator_A output BSL receive
P2.3/CA0/TA1	23	I/O	General-purpose digital I/O pin Timer_A, compare: Out1 output Comparator_A input
P2.4/CA1/TA2	24	I/O	General-purpose digital I/O pin Timer_A, compare: Out2 output Comparator_A input
P2.5/R _{OSC}	25	I/O	General-purpose digital I/O pin Input for external resistor defining the DCO nominal frequency
P2.6	26	I/O	General-purpose digital I/O pin
P2.7/TA0	27	I/O	General-purpose digital I/O pin Timer_A, compare: Out0 output
P3.0/STE0	28	I/O	General-purpose digital I/O pin Slave transmit enable for USART0 in SPI mode
P3.1/SIM00	29	I/O	General-purpose digital I/O pin Slave in/master out of USART0 in SPI mode
P3.2/SOMI0	30	I/O	General-purpose digital I/O pin Slave out/master in of USART0 in SPI mode
P3.3/UCLK0	31	I/O	General-purpose digital I/O USART0 clock: external input in UART or SPI mode, output in SPI mode
P3.4/UTXD0	32	I/O	General-purpose digital I/O pin Transmit data out for USART0 in UART mode
P3.5/URXD0	33	I/O	General-purpose digital I/O pin Receive data in for USART0 in UART mode

Table 4-2. Signal Descriptions for MSP430F14x1 (continued)

SIGNAL NAME	PIN NO.	I/O	DESCRIPTION
P3.6/UTXD1	34	I/O	General-purpose digital I/O pin Transmit data out for USART1 in UART mode
P3.7/URXD1	35	I/O	General-purpose digital I/O pin Receive data in for USART1 in UART mode
P4.0/TB0	.36	I/O	General-purpose digital I/O pin Timer_B, capture: CCI0A or CCI0B input, compare: Out0 output
P4.1/TB1	37	I/O	General-purpose digital I/O pin Timer_B, capture: CCI1A or CCI1B input, compare: Out1 output
P4.2/TB2	38	I/O	General-purpose digital I/O pin Timer_B, capture: CCI2A or CCI2B input, compare: Out2 output
P4.3/TB3	39	I/O	General-purpose digital I/O pin Timer_B, capture: CCI3A or CCI3B input, compare: Out3 output
P4.4/TB4	40	I/O	General-purpose digital I/O pin Timer_B, capture: CCI4A or CCI4B input, compare: Out4 output
P4.5/TB5	41	I/O	General-purpose digital I/O pin Timer_B, capture: CCI5A or CCI5B input, compare: Out5 output
P4.6/TB6	42	I/O	General-purpose digital I/O pin Timer_B, capture: CCI6A or CCI6B input, compare: Out6 output
P4.7/TBCLK	43	I/O	General-purpose digital I/O pin Timer_B, clock signal TBCLK input
P5.0/STE1	44	I/O	General-purpose digital I/O pin Slave transmit enable for USART1 in SPI mode
P5.1/SIMO1	45	I/O	General-purpose digital I/O pin Slave in/master out of USART1 in SPI mode
P5.2/SOMI1	46	I/O	General-purpose digital I/O pin Slave out/master in of USART1 in SPI mode
P5.3/UCLK1	47	I/O	General-purpose digital I/O pin USART1 clock: external input in UART or SPI mode, output in SPI mode
P5.4/MCLK	48	I/O	General-purpose digital I/O pin Main system clock MCLK output
P5.5/SMCLK	49	I/O	General-purpose digital I/O pin Submain system clock SMCLK output
P5.6/ACLK	50	I/O	General-purpose digital I/O pin Auxiliary clock ACLK output
P5.7/TBOUTH	51	I/O	General-purpose digital I/O pin Switch all PWM digital output ports to high impedance for Timer_B7 (TB0 to TB6)
P6.0	59	I/O	General-purpose digital I/O pin
P6.1	60	I/O	General-purpose digital I/O pin
P6.2	61	I/O	General-purpose digital I/O pin
P6.3	2	I/O	General-purpose digital I/O pin
P6.4	3	I/O	General-purpose digital I/O pin
P6.5	4	I/O	General-purpose digital I/O pin
P6.6	5	I/O	General-purpose digital I/O pin
P6.7	6	I/O	General-purpose digital I/O pin
$\overline{\text{RST}}$ /NMI	58	I	Reset input Nonmaskable interrupt input port Bootloader start
TCK	57	I	Test clock, the clock input port for device programming test and bootloader start
TDI/TCLK	55	I	Test data input or test clock input. The device protection fuse is connected to TDI/TCLK.
TDO/TDI	54	I/O	Test data output or programming data input
TMS	56	I	Test mode select, used as an input port for device programming and test
DV _{SS}	10	I	Connect to DV _{SS}
Reserved	7		Reserved, do not connect externally

Table 4-2. Signal Descriptions for MSP430F14x1 (continued)

SIGNAL NAME	PIN NO.	I/O	DESCRIPTION
DV _{SS}	11	I	Connect to DV _{SS}
XIN	8	I	Input port for crystal oscillator XT1. Standard or watch crystals can be connected.
XOUT	9	O	Output terminal of crystal oscillator XT1
XT2IN	53	I	Input port for crystal oscillator XT2. Only standard crystals can be connected.
XT2OUT	52	O	Output terminal of crystal oscillator XT2
QFN Pad	NA	NA	QFN package pad, connect to DV _{SS}

5 Specifications

5.1 Absolute Maximum Ratings⁽¹⁾

over operating free-air temperature range (unless otherwise noted)

	MIN	MAX	UNIT	
Voltage applied at V_{CC} to V_{SS}	-0.3	4.1	V	
Voltage applied to any pin ⁽²⁾	-0.3	$V_{CC} + 0.3$	V	
Diode current at any device terminal		±2	mA	
Storage temperature	Programmed device	-40	85	°C
	Unprogrammed device	-55	150	

- (1) Stresses beyond those listed under absolute maximum ratings may cause permanent damage to the device. These are stress ratings only, and functional operation of the device at these or any other conditions beyond those indicated under recommended operating conditions is not implied. Exposure to absolute-maximum-rated conditions for extended periods may affect device reliability.
- (2) All voltage values are with respect to V_{SS} , unless otherwise noted. The JTAG fuse-blow voltage, V_{FB} , is allowed to exceed the absolute maximum rating. The voltage is applied to the TDI/TCLK pin when blowing the JTAG fuse.

5.2 ESD Ratings

			VALUE	UNIT
$V_{(ESD)}$	Electrostatic discharge ratings	Human-body model (HBM), per ANSI/ESDA/JEDEC JS-001 ⁽¹⁾	±1000	V
		Charged-device model (CDM), per JEDEC specification JESD22-C101 ⁽²⁾	±250	

- (1) JEDEC document JEP155 states that 500-V HBM allows safe manufacturing with a standard ESD control process. Pins listed as ±1000 V may actually have higher performance.
- (2) JEDEC document JEP157 states that 250-V CDM allows safe manufacturing with a standard ESD control process. Pins listed as ±250 V may actually have higher performance.

5.3 Recommended Operating Conditions

Typical values are specified at $V_{CC} = 3.3$ V and $T_A = 25^\circ\text{C}$ (unless otherwise noted)

			MIN	NOM	MAX	UNIT
V_{CC}	Supply voltage ($AV_{CC} = DV_{CC} = V_{CC}$)	During program execution	1.8		3.6	V
		During flash memory programming	2.7		3.6	
V_{SS}	Supply voltage ($AV_{SS} = DV_{SS} = V_{SS}$)		0		0	V
T_A	Operating free-air temperature		-40		85	°C
f_{LFXT1}	LFXT1 crystal frequency ⁽¹⁾	LF selected, XTS = 0, watch crystal		32768		Hz
		XT1 selected, XTS = 1, ceramic resonator	450		8000	kHz
		XT1 selected, XTS = 1, crystal	1000		8000	
f_{XT2}	XT2 crystal frequency ⁽¹⁾	Ceramic resonator	450		8000	kHz
		Crystal	1000		8000	
f_{SYSTEM}	Processor frequency (signal MCLK)	$V_{CC} = 1.8$ V	DC		4.15	MHz
		$V_{CC} = 3.6$ V	DC		8	

- (1) In LF mode, the LFXT1 oscillator requires a watch crystal. TI recommends a 5.1-M Ω resistor from XOUT to V_{SS} when $V_{CC} < 2.5$ V. In XT1 mode, the LFXT1 and XT2 oscillators accept a ceramic resonator or crystal up to 4.15 MHz at $V_{CC} \geq 2.2$ V. In XT1 mode, the LFXT1 and XT2 oscillators accept a ceramic resonator or crystal up to 8 MHz at $V_{CC} \geq 2.8$ V.

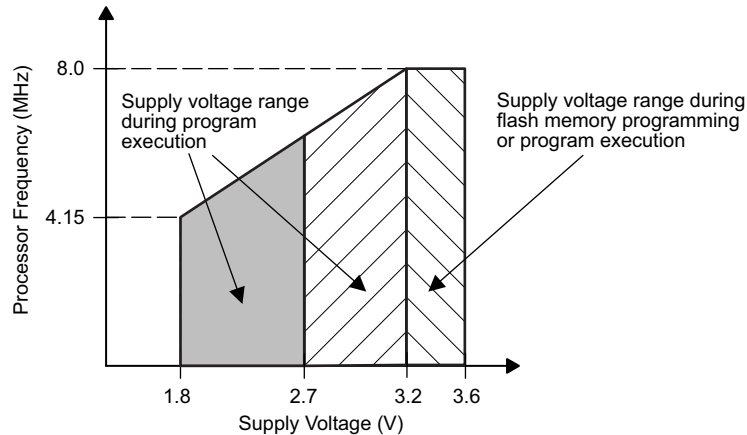
Figure 5-1. Frequency vs Supply Voltage

5.4 Supply Current Into AV_{CC} and DV_{CC} Excluding External Current

over recommended operating supply voltage and free-air temperature (unless otherwise noted)

PARAMETER	TEST CONDITIONS	T _A	V _{CC}	MIN	TYP	MAX	UNIT	
I _(AM) Active mode supply current ⁽¹⁾	f _(MCLK) = f _(SMCLK) = 1 MHz, f _(ACLK) = 32768 Hz, XTS = 0, SELM = 0 or 1	–40°C to 85°C	2.2 V		280	360	μA	
			3 V		420	560		
		–40°C to 85°C	2.2 V		2.5	7		
			3 V		9	20		
I _(LPM0) Low-power mode 0 (LPM0) supply current ⁽¹⁾		–40°C to 85°C	2.2 V		32	45	μA	
			3 V		55	70		
I _(LPM2) Low-power mode 2 (LPM2) supply current	f _(MCLK) = f _(SMCLK) = 0 MHz, f _(ACLK) = 32768 Hz, SCG0 = 0	–40°C to 85°C	2.2 V		11	14	μA	
			3 V		17	22		
I _(LPM3) Low-power mode 3 (LPM3) supply current	f _(MCLK) = f _(SMCLK) = 0 MHz, f _(ACLK) = 32768 Hz, SCG0 = 1 ⁽²⁾	–40°C	2.2 V		0.8	1.5	μA	
				25°C		0.9		1.5
				85°C		1.6		2.8
		–40°C	3 V		1.8	2.2		
				25°C		1.6		1.9
				85°C		2.3		3.9
I _(LPM4) Low-power mode 4 (LPM4) supply current	f _(MCLK) = f _(SMCLK) = f _(ACLK) = 0 MHz, SCG0 = 1	–40°C	2.2 V		0.1	0.5	μA	
				25°C		0.1		0.5
				85°C		0.8		2.5
		–40°C	3 V		0.1	0.5		
				25°C		0.1		0.5
				85°C		0.8		2.5

(1) Timer_B is clocked by f_(DCOCLK) = 1 MHz. All inputs are tied to 0 V or to V_{CC}. Outputs do not source or sink any current.

(2) Timer_B is clocked by f_(ACLK) = 32768 Hz. All inputs are tied to 0 V or to V_{CC}. Outputs do not source or sink any current. The current consumption in LPM2 and LPM3 are measured with ACLK selected.

Current consumption of active mode versus system frequency

$$I_{(AM)} = I_{(AM)} [1 \text{ MHz}] \times f_{(\text{System})} [\text{MHz}]$$

Current consumption of active mode versus supply voltage

$$I_{(AM)} = I_{(AM)} [3 \text{ V}] + 175 \mu\text{A/V} \times (V_{\text{CC}} - 3 \text{ V})$$

5.5 Thermal Resistance Characteristics

over recommended operating supply voltage and free-air temperature (unless otherwise noted)

THERMAL METRIC ⁽¹⁾		VALUE ⁽²⁾			UNIT
		64-PIN PM	64-PIN PAG	64-PIN RTD	
R _{θJA}	Junction-to-ambient thermal resistance, still air	52.0	52.7	25.0	°C/W
R _{θJC(TOP)}	Junction-to-case (top) thermal resistance	14.4	11.2	14.2	°C/W
R _{θJB}	Junction-to-board thermal resistance	23.0	23.4	9.6	°C/W
Ψ _{JB}	Junction-to-board thermal characterization parameter	22.7	23.1	9.5	°C/W
Ψ _{JT}	Junction-to-top thermal characterization parameter	0.6	0.3	0.2	°C/W
R _{θJC(BOTTOM)}	Junction-to-case (bottom) thermal resistance	N/A ⁽³⁾	N/A ⁽³⁾	1.3	°C/W

(1) For more information about traditional and new thermal metrics, see [Semiconductor and IC Package Thermal Metrics](#).

(2) These values are based on a JEDEC-defined 2S2P system (with the exception of the Theta JC (R_{θJC}) value, which is based on a JEDEC-defined 1S0P system) and will change based on environment and application. For more information, see these EIA/JEDEC standards:

- JESD51-2, *Integrated Circuits Thermal Test Method Environmental Conditions - Natural Convection (Still Air)*
- JESD51-3, *Low Effective Thermal Conductivity Test Board for Leaded Surface Mount Packages*
- JESD51-7, *High Effective Thermal Conductivity Test Board for Leaded Surface Mount Packages*
- JESD51-9, *Test Boards for Area Array Surface Mount Package Thermal Measurements*

(3) N/A = not applicable

5.6 Schmitt-Trigger Inputs – Ports P1, P2, P3, P4, P5, and P6

over recommended operating supply voltage and free-air temperature (unless otherwise noted)

PARAMETER		V _{CC}	MIN	MAX	UNIT
V _{IT+}	Positive-going input threshold voltage	2.2 V	1.1	1.5	V
		3 V	1.5	1.9	
V _{IT-}	Negative-going input threshold voltage	2.2 V	0.4	0.9	V
		3 V	0.9	1.3	
V _{hys}	Input voltage hysteresis (V _{IT+} – V _{IT-})	2.2 V	0.3	1.1	V
		3 V	0.5	1	

5.7 Standard Inputs – \overline{RST}/NMI , JTAG (TCK, TMS, TDI/TCLK, TDO/TDI)

over recommended operating supply voltage and free-air temperature (unless otherwise noted)

PARAMETER		V _{CC}	MIN	MAX	UNIT
V _{IL}	Low-level input voltage	2.2 V, 3 V	V _{SS}	V _{SS} + 0.6	V
V _{IH}	High-level input voltage		0.8 × V _{CC}	V _{CC}	V

5.8 Inputs – P_{x.y}, T_{Ax}, T_{Bx}

over recommended operating supply voltage and free-air temperature (unless otherwise noted)

PARAMETER		TEST CONDITIONS	V _{CC}	MIN	MAX	UNIT
t _(int)	External interrupt timing	Port P1.x and P2.x, External trigger pulse duration to set interrupt flag ⁽¹⁾	2.2 V, 3 V	1.5		cycle
			2.2 V	62		ns
			3 V	50		
t _(cap)	Timer A or Timer B capture timing	TA0, TA1, TA2, TB0, TB1, TB2, TB3, TB4, TB5, TB6 ⁽²⁾	2.2 V	62		ns
			3 V	50		
f _(TAext) , f _(TBext)	Timer_A or Timer_B clock frequency externally applied to pin	TACLK, TBCLK, INCLK: t _(H) = t _(L)	2.2 V		8	MHz
			3 V		10	

(1) The external signal sets the interrupt flag every time the minimum t_(int) cycle and time parameters are met. It may be set even with trigger signals shorter than t_(int). Both the cycle and timing specifications must be met to ensure the flag is set. t_(int) is measured in MCLK cycles.

(2) Seven Timer_B capture/compare registers in MSP430F14x and MSP430F14x devices, and three Timer_B capture/compare registers in MSP430F13x devices.

Inputs – Px.y, TAx, TBx (continued)

over recommended operating supply voltage and free-air temperature (unless otherwise noted)

PARAMETER		TEST CONDITIONS	V _{CC}	MIN	MAX	UNIT
f _(TAint) , f _(TBint)	Timer_A or Timer_B clock frequency	SMCLK or ACLK signal selected	2.2 V		8	MHz
			3 V		10	

5.9 Leakage Current

over recommended operating supply voltage and free-air temperature (unless otherwise noted)

PARAMETER		TEST CONDITIONS	V _{CC}	MIN	MAX	UNIT
I _{lkg(P1.x)}	Leakage current ⁽¹⁾	Port P1	2.2 V, 3 V		±50	nA
I _{lkg(P2.x)}		Port P2		V _(P2.3) , V _(P2.4) ⁽²⁾	±50	
I _{lkg(P6.x)}		Port P6		V _(P6.x) ⁽²⁾	±50	

(1) The leakage current is measured with V_{SS} or V_{CC} applied to the corresponding pin, unless otherwise noted.

(2) The port pin must be set as input, and the optional pullup or pulldown resistor must be disabled.

5.10 Outputs – Ports P1, P2, P3, P4, P5, and P6

over recommended operating supply voltage and free-air temperature (unless otherwise noted)

PARAMETER		TEST CONDITIONS	V _{CC}	MIN	MAX	UNIT
V _{OH}	High-level output voltage	I _(OHmax) = -1 mA ⁽¹⁾	2.2 V	V _{CC} - 0.25	V _{CC}	V
		I _(OHmax) = -6 mA ⁽²⁾		V _{CC} - 0.60	V _{CC}	
		I _(OHmax) = 1 mA ⁽¹⁾	3 V	V _{CC} - 0.25	V _{CC}	
		I _(OHmax) = -6 mA ⁽²⁾		V _{CC} - 0.60	V _{CC}	
V _{OL}	Low-level output voltage	I _(OLmax) = 1.5 mA ⁽¹⁾	2.2 V	V _{SS}	V _{SS} + 0.25	V
		I _(OLmax) = 6 mA ⁽²⁾		V _{SS}	V _{SS} + 0.6	
		I _(OLmax) = 1.5 mA ⁽¹⁾	3 V	V _{SS}	V _{SS} + 0.25	
		I _(OLmax) = 6 mA ⁽²⁾		V _{SS}	V _{SS} + 0.6	

(1) The maximum total current, I_(OHmax) and I_(OLmax), for all outputs combined, must not exceed ±6 mA to hold the maximum voltage drop specified.

(2) The maximum total current, I_(OHmax) and I_(OLmax), for all outputs combined, must not exceed ±24 mA to hold the maximum voltage drop specified.

5.11 Output Frequency

over recommended operating supply voltage and free-air temperature (unless otherwise noted)

PARAMETER		TEST CONDITIONS	MIN	TYP	MAX	UNIT
f _{TAx}	Timer_A or Timer_B output frequency	Internal clock source, SMCLK signal applied ⁽¹⁾ , TA0 to TA2, TB0 to TB6, C _L = 20 pF	DC		f _{SYSTEM}	MHz
f _{ACLK}	Clock output frequency	Measured at P5.6/ACLK			f _{SYSTEM}	MHz
f _{MCLK}		Measured at P5.4/MCLK			f _{SYSTEM}	
f _{SMCLK}		Measured at P5.5/SMCLK			f _{SYSTEM}	
t _{Xdc}	Duty cycle of output frequency	Measured at P2.0/ACLK, C _L = 20 pF, V _{CC} = 2.2 V or 3 V	f _{ACLK} = f _{LFXT1} = f _{XT1}	40%	60%	
			f _{ACLK} = f _{LFXT1} = f _{LF}	30%	70%	
			f _{ACLK} = f _{LFXT1/n}	50%		
		Measured at P1 4/SMCLK, C _L = 20 pF, V _{CC} = 2.2 V or 3 V	f _{SMCLK} = f _{LFXT1} = f _{XT1}	40%	60%	
			f _{SMCLK} = f _{LFXT1} = f _{LF}	35%	65%	
			f _{SMCLK} = f _{LFXT1/n}	50% - 15 ns	50% + 15 ns	
f _{SMCLK} = f _{DCOCLK}	50% - 15 ns	50% + 15 ns				

(1) The limits of the system clock MCLK must be met; the MCLK frequency must not exceed the limits. MCLK and SMCLK frequencies can be different.

5.12 Typical Characteristics – Ports P1, P2, P3, P4, P5, and P6 Outputs

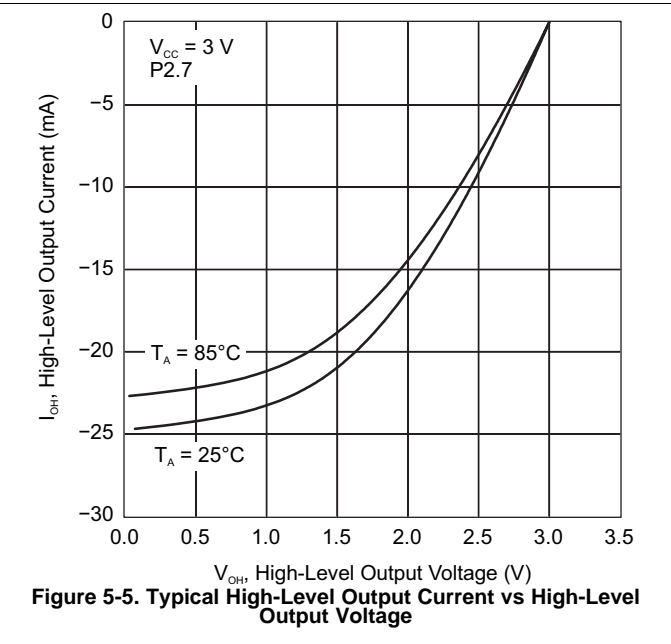
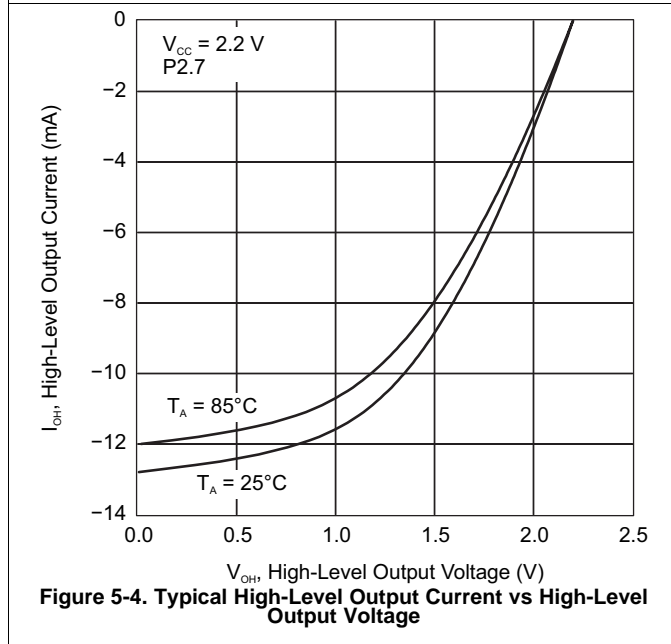
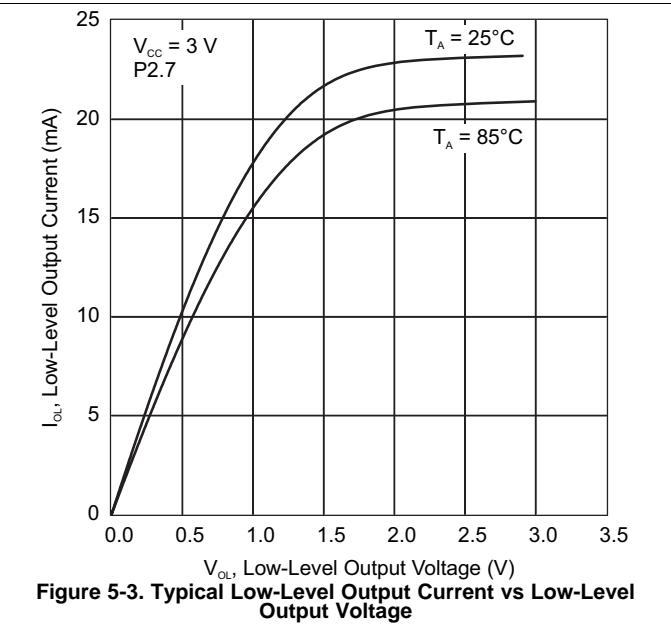
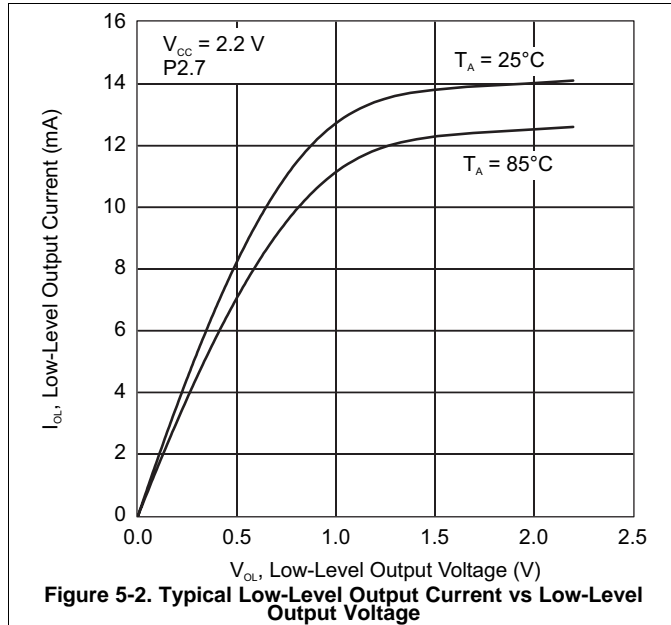

5.13 Wake-up Time From LPM3

over recommended operating supply voltage and free-air temperature (unless otherwise noted)

PARAMETER	TEST CONDITIONS	V _{CC}	MIN	MAX	UNIT
t _(LPM3) Wake-up time from LPM3	f = 1 MHz	2.2 V, 3 V		6	μs
	f = 2 MHz			6	
	f = 3 MHz			6	

5.14 RAM

over recommended operating supply voltage and free-air temperature (unless otherwise noted)

PARAMETER	TEST CONDITIONS	MIN	MAX	UNIT
V _{RAMh} Minimum supply voltage ⁽¹⁾	CPU halted	1.6		V

(1) This parameter defines the minimum supply voltage when the data in program memory RAM remain unchanged. No program execution should take place during this supply voltage condition.

5.15 Comparator_A⁽¹⁾

over recommended operating supply voltage and free-air temperature (unless otherwise noted)

PARAMETER	TEST CONDITIONS	V _{CC}	MIN	TYP	MAX	UNIT
I _(DD) Supply current	CAON = 1 CARSEL = 0 CAREF = 0	2.2 V		25	40	μA
		3 V		45	60	
I _(Refladder/Refdiode) Reference ladder supply current	CAON = 1, CARSEL = 0, CAREF 1, 2, or 3, No load at P2.3/CA0/TA1 and P2.4/CA1/TA2	2.2 V		30	50	μA
		3 V		45	71	
V _(IC) Common-mode input voltage	CAON = 1	2.2 V, 3 V	0		V _{CC} – 1	V
V _(Ref025) Ratio of (voltage at 0.25 V _{CC} node) / V _{CC}	PCA0 = 1, CARSEL = 1, CAREF = 1, No load at P2.3/CA0/TA1 and P2.4/CA1/TA2	2.2 V, 3 V	0.23	0.24	0.25	
V _(Ref050) Ratio of (voltage at 0.5 V _{CC} node) / V _{CC}	PCA0 = 1, CARSEL = 1, CAREF = 2, No load at P2.3/CA0/TA1 and P2.4/CA1/TA2	2.2 V, 3 V	0.47	0.48	0.5	
V _(RefVT) Reference voltage (see Figure 5-6 and Figure 5-7)	PCA0 = 1, CARSEL = 1, CAREF = 3, No load at P2.3/CA0/TA1 and P2.4/CA1/TA2, T _A = 85°C	2.2 V	390	480	540	mV
		3 V	400	490	550	
V _(offset) Offset voltage ⁽²⁾		2.2 V, 3 V	–30		30	mV
V _{hys} Input hysteresis	CAON = 1	2.2 V, 3 V	0	0.7	1.4	mV
t _(response LH) Low-to-high response time	T _A = 25°C, Overdrive = 10 mV, Without filter: CAF = 0	2.2 V	130	210	300	ns
		3 V	80	150	240	
	T _A = 25°C, Overdrive = 10 mV, Without filter: CAF = 1	2.2 V	1.4	1.9	3.4	μs
		3 V	0.9	1.5	2.6	
t _(response HL) High-to-low response time	T _A = 25°C, Overdrive = 10 mV, Without filter: CAF = 0	2.2 V	130	210	300	ns
		3 V	80	150	240	
	T _A = 25°C, Overdrive = 10 mV, Without filter: CAF = 1	2.2 V	1.4	1.9	3.4	μs
		3 V	0.9	1.5	2.6	

(1) The leakage current for the Comparator_A terminals is identical to the I_(kgP_{x,x}) specification.

(2) The input offset voltage can be cancelled by using the CAEX bit to invert the Comparator_A inputs on successive measurements. The two successive measurements are then summed together.

5.16 Typical Characteristics – Comparator_A

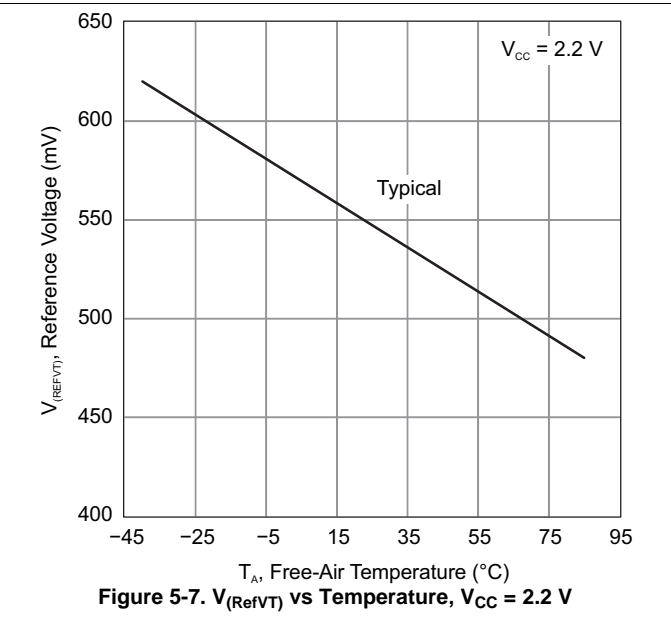
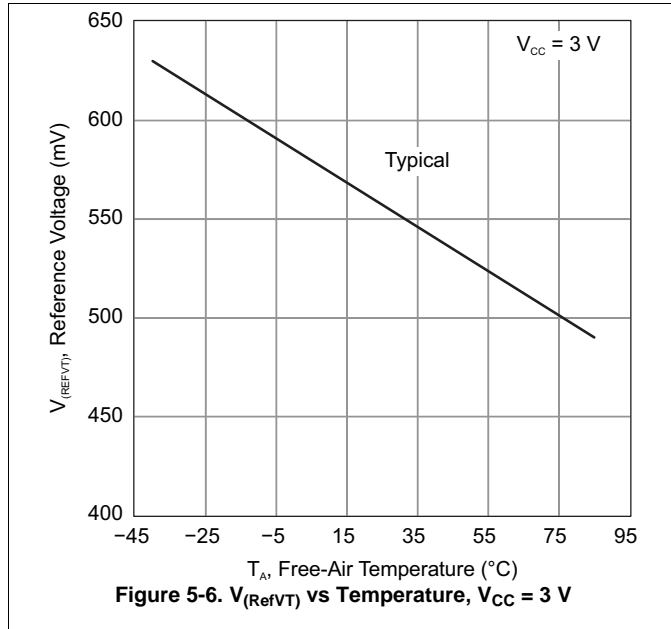

5.17 PUC and POR

PARAMETER	TEST CONDITIONS	V _{CC}	MIN	TYP	MAX	UNIT
t _(POR_Delay)	Internal time delay to release POR			150	250	μs
V _{POR}	V _{CC} threshold at which POR release delay time begins ⁽¹⁾	2.2 V, 3 V	T _A = -40°C	1.4	1.8	V
			T _A = 25°C	1.1	1.5	
			T _A = 85°C	0.8	1.2	
V _(min)	V _{CC} threshold required to generate a POR ⁽²⁾	V _{CC} dV/dt ≥ 1 V/ms	2.2 V, 3 V	0.2		V
t _(reset)	RST/NMI low time for PUC or POR	Reset is accepted internally	2.2 V, 3 V	2		μs

(1) V_{CC} rise time dV/dt ≥ 1 V/ms

(2) When driving V_{CC} low to generate a POR condition, drive V_{CC} to 200 mV or lower with a dV/dt equal to or less than -1 V/ms. The corresponding rising V_{CC} must also meet the dV/dt requirement equal to or greater than +1 V/ms.



Figure 5-10. V_{POR} vs Supply Voltage

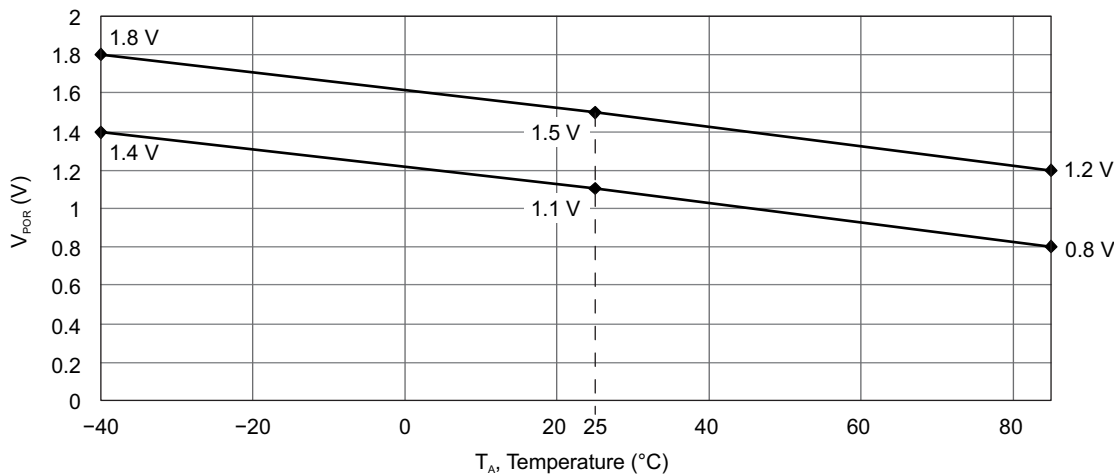

Figure 5-11. V_{POR} vs Temperature

5.18 DCO Frequency⁽¹⁾

over recommended operating supply voltage and free-air temperature (unless otherwise noted)

PARAMETER	TEST CONDITIONS	V _{CC}	MIN	TYP	MAX	UNIT
f _{DCO(03)}	Rsel = 0, DCO = 3, MOD = 0, DCOR = 0, T _A = 25°C	2.2 V, 3 V	0.08	0.12	0.15	MHz
			0.08	0.13	0.16	
f _{DCO(13)}	Rsel = 1, DCO = 3, MOD = 0, DCOR = 0, T _A = 25°C	2.2 V, 3 V	0.14	0.19	0.23	MHz
			0.14	0.18	0.22	
f _{DCO(23)}	Rsel = 2, DCO = 3, MOD = 0, DCOR = 0, T _A = 25°C	2.2 V, 3 V	0.22	0.30	0.36	MHz
			0.22	0.28	0.34	
f _{DCO(33)}	Rsel = 3, DCO = 3, MOD = 0, DCOR = 0, T _A = 25°C	2.2 V, 3 V	0.37	0.49	0.59	MHz
			0.37	0.47	0.56	
f _{DCO(43)}	Rsel = 4, DCO = 3, MOD = 0, DCOR = 0, T _A = 25°C	2.2 V, 3 V	0.61	0.77	0.93	MHz
			0.61	0.75	0.90	
f _{DCO(53)}	Rsel = 5, DCO = 3, MOD = 0, DCOR = 0, T _A = 25°C	2.2 V, 3 V	1	1.2	1.5	MHz
			1	1.3	1.5	
f _{DCO(63)}	Rsel = 6, DCO = 3, MOD = 0, DCOR = 0, T _A = 25°C	2.2 V, 3 V	1.6	1.9	2.2	MHz
			1.69	2.0	2.29	
f _{DCO(73)}	Rsel = 7, DCO = 3, MOD = 0, DCOR = 0, T _A = 25°C	2.2 V, 3 V	2.4	2.9	3.4	MHz
			2.7	3.2	3.65	
f _{DCO(47)}	Rsel = 4, DCO = 7, MOD = 0, DCOR = 0, T _A = 25°C	2.2 V, 3 V	f _{DCO40} × 1.7	f _{DCO40} × 2.1	f _{DCO40} × 2.5	MHz
f _{DCO(77)}	Rsel = 7, DCO = 7, MOD = 0, DCOR = 0, T _A = 25°C	2.2 V, 3 V	4	4.5	4.9	MHz
			4.4	4.9	5.4	
S _{Rsel}	S _{Rsel} = f _{Rsel+1} / f _{Rsel}	2.2 V, 3 V	1.35	1.65	2	
S _{DCO}	S _{DCO} = f _{DCO+1} / f _{DCO}	2.2 V, 3 V	1.07	1.12	1.16	
D _t	Temperature drift ⁽²⁾ , Rsel = 4, DCO = 3, MOD = 0	2.2 V, 3 V	-0.31	-0.36	-0.40	%/ ^o C
			-0.33	-0.38	-0.43	
D _V	Drift with V _{CC} variation ⁽²⁾ , Rsel = 4, DCO = 3, MOD = 0	2.2 V, 3 V	0	5	10	%/V

(1) The DCO frequency may not exceed the maximum system frequency defined by the processor frequency parameter, f_{SYSTEM}.

(2) This parameter is not production tested.

DCO Characteristics (see Figure 5-12)

- Individual devices have a minimum and maximum operation frequency. The specified parameters for $f_{\text{DCO}(x0)}$ to $f_{\text{DCO}(x7)}$ are valid for all devices.
- All ranges selected by Rsel(n) overlap with Rsel(n+1); for example, Rsel0 overlaps with Rsel1, and Rsel6 overlaps with Rsel7.
- DCO control bits DCO0, DCO1, and DCO2 have a step size as defined by parameter S_{DCO} .
- Modulation control bits MOD0 to MOD4 select how often $f_{\text{DCO}+1}$ is used within the period of 32 DCOCLK cycles. The frequency f_{DCO} is used for the remaining cycles. The frequency is an average equal to $f_{\text{DCO}} \times 2^{\text{MOD}/32}$.

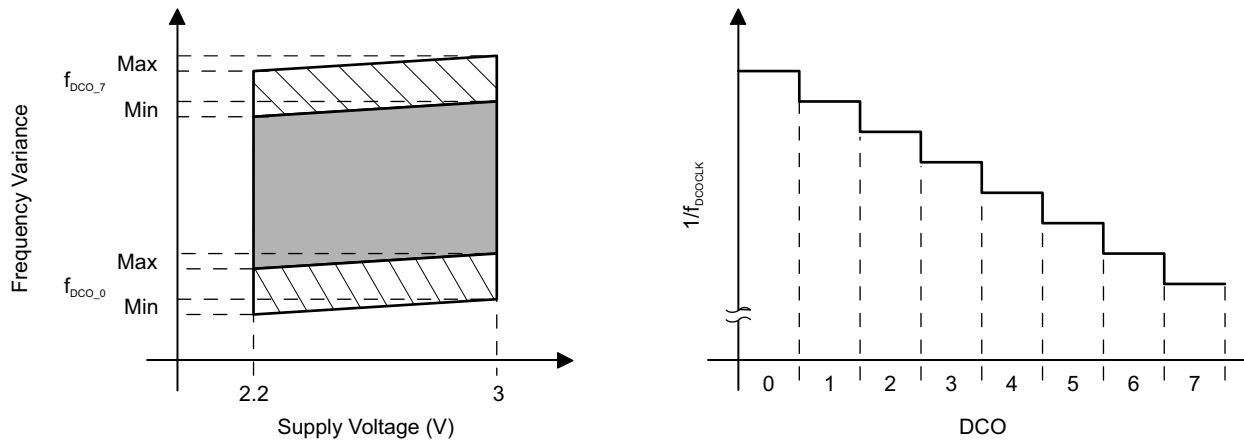

Figure 5-12. DCO Characteristics

5.19 DCO When Using R_{osc}

over recommended operating supply voltage and free-air temperature (unless otherwise noted)⁽¹⁾

PARAMETER	TEST CONDITIONS	V_{CC}	MIN	TYP	MAX	UNIT
f_{DCO}	DCO output frequency	Rsel = 4, DCO = 3, MOD = 0, DCOR = 1, $T_A = 25^\circ\text{C}$	2.2 V	1.8 ±15%		MHz
			3 V	1.95 ±15%		
D_t	Temperature drift	Rsel = 4, DCO = 3, MOD = 0, DCOR = 1	2.2 V, 3 V	±0.1		%/°C
D_v	Drift with V_{CC} variation	Rsel = 4, DCO = 3, MOD = 0, DCOR = 1	2.2 V, 3 V	10		%/V

(1) $R_{\text{osc}} = 100 \text{ k}\Omega$, metal film resistor, type 0257, 0.6 W, 1% tolerance, $T_K = \pm 50 \text{ ppm}/^\circ\text{C}$

5.20 Crystal Oscillator, LFXT1

over recommended operating supply voltage and free-air temperature (unless otherwise noted)⁽¹⁾

PARAMETER		TEST CONDITIONS	V _{CC}	MIN	TYP	MAX	UNIT
C _{XIN}	Integrated input capacitance	XTS = 0, LF oscillator selected	2.2 V, 3 V	12			pF
		XTS = 1, XT1 oscillator selected		2			
C _{XOUT}	Integrated output capacitance	XTS = 0, LF oscillator selected	2.2 V, 3 V	12			pF
		XTS = 1, XT1 oscillator selected		2			
V _{IL}	Low-level input voltage at XIN ⁽²⁾		2.2 V, 3 V	V _{SS}		0.2 × V _{CC}	V
V _{IH}	High-level input voltage at XIN ⁽²⁾		2.2 V, 3 V	0.8 × V _{CC}		V _{CC}	V

(1) The oscillator needs capacitors at both terminals, with values specified by the crystal manufacturer.

(2) Applies only when using an external logic-level clock source. Not applicable when using a crystal or resonator.

5.21 Crystal Oscillator, XT2

over recommended operating supply voltage and free-air temperature (unless otherwise noted)⁽¹⁾

PARAMETER		V _{CC}	MIN	TYP	MAX	UNIT
C _{XT2IN}	Input capacitance	2.2 V, 3 V		2		pF
C _{XT2OUT}	Output capacitance	2.2 V, 3 V		2		pF
V _{IL}	Low-level input voltage at XT2IN ⁽²⁾	2.2 V, 3 V	V _{SS}		0.2 × V _{CC}	V
V _{IH}	High-level input voltage at XT2IN ⁽²⁾	2.2 V, 3 V	0.8 × V _{CC}		V _{CC}	V

(1) The oscillator needs capacitors at both terminals, with values specified by the crystal manufacturer.

(2) Applies only when using an external logic-level clock source. Not applicable when using a crystal or resonator.

5.22 USART0, USART1

over recommended operating supply voltage and free-air temperature (unless otherwise noted)

PARAMETER		V _{CC}	MIN	TYP	MAX	UNIT
t _(τ)	USART0 or USART1 deglitch time ⁽¹⁾	2.2 V	200	430	800	ns
		3 V	150	280	500	

(1) The signal applied to the USART0 USART1 receive terminal (URXD0 or URXD1) must meet the timing requirements of t_(τ) to ensure that the URXS flip-flop is set. The URXS flip-flop is set with negative pulses meeting the minimum timing condition of t_(τ). The operating conditions to set the flag must be met independently from this timing constraint. The deglitch circuitry is active only on negative transitions on the URXD0 or URXD1 line.

5.23 12-Bit ADC, Power Supply and Input Range Conditions

over recommended operating supply voltage and free-air temperature (unless otherwise noted)⁽¹⁾

PARAMETER	TEST CONDITIONS	V _{CC}	MIN	TYP	MAX	UNIT	
AV _{CC}	Analog supply voltage	AV _{CC} and DV _{CC} are connected together, AV _{SS} and DV _{SS} are connected together, V _(AVSS) = V _(DVSS) = 0 V		2.2		3.6	V
V _(P6.x/Ax)	Analog input voltage ⁽²⁾	All P6.0/A0 to P6.7/A7 terminals, analog inputs selected in ADC12MCTLx register and P6Sel.x = 1, 0 ≤ x ≤ 7, V _(AVSS) ≤ V _(P6.x/Ax) ≤ V _(AVCC)		0		V _{AVCC}	V
I _{ADC12}	ADC operating supply current into AV _{CC} terminal ⁽³⁾	f _{ADC12CLK} = 5.0 MHz, ADC12ON = 1, REFON = 0, SHT0 = 0, SHT1 = 0, ADC12DIV = 0	2.2 V		0.65	1.3	mA
			3 V		0.8	1.6	
I _{REF+}	REF operating supply current into AV _{CC} terminal ⁽⁴⁾	f _{ADC12CLK} = 5.0 MHz, ADC12ON = 0, REFON = 1, REF2_5V = 1	3 V		0.5	0.8	mA
		f _{ADC12CLK} = 5.0 MHz, ADC12ON = 0, REFON = 1, REF2_5V = 0	2.2 V		0.5	0.8	
			3 V		0.5	0.8	
C _I	Input capacitance ⁽⁵⁾	Only one P6.x/Ax terminal can be selected at one time	2.2 V			40	pF
R _I	Input MUX ON resistance ⁽⁵⁾	0 V ≤ V _{Ax} ≤ V _{AVCC}	3 V			2000	Ω

(1) The leakage current is defined in the leakage current table.

(2) The analog input voltage range must be within the selected reference voltage range V_{R+} to V_{R-} for valid conversion results.

(3) The internal reference supply current is not included in current consumption parameter I_{ADC12}.

(4) The internal reference current is supplied through the AV_{CC} terminal. Consumption is independent of the ADC12ON control bit, unless a conversion is active. The REFON bit enables to settle the built-in reference before starting a conversion.

(5) Not production tested, limits verified by design.

5.24 12-Bit ADC, External Reference

over recommended operating supply voltage and free-air temperature (unless otherwise noted)⁽¹⁾

PARAMETER	TEST CONDITIONS	V _{CC}	MIN	MAX	UNIT	
V _{VeREF+}	Positive external reference input voltage	V _{VeREF+} > V _{VREF-/VeREF-} ⁽²⁾		1.4 V _{AVCC}	V	
V _{VREF-/VeREF-}	Negative external reference input voltage	V _{VeREF+} > V _{VREF-/VeREF-} ⁽³⁾		0	1.2	V
V _{VeREF+} – V _{VREF-/VeREF-}	Differential external reference input voltage	V _{VeREF+} > V _{VREF-/VeREF-} ⁽⁴⁾		1.4 V _{AVCC}		V
I _{VeREF+}	Static input current, VeREF+	0 V ≤ V _{VeREF+} ≤ V _{AVCC}	2.2 V, 3 V		±1	μA
I _{VREF-/VeREF-}	Static input current, VeREF-	0 V ≤ V _{VREF-/VeREF-} ≤ V _{AVCC}	2.2 V, 3 V		±1	μA

(1) The external reference is used during conversion to charge and discharge the capacitance array. The input capacitance, C_I, is also the dynamic load for an external reference during conversion. The dynamic impedance of the reference supply should follow the recommendations on analog-source impedance to allow the charge to settle for 12-bit accuracy.

(2) The accuracy requirements limit the minimum positive external reference voltage. Lower reference voltage levels may be applied with reduced accuracy requirements.

(3) The accuracy requirements limit the maximum negative external reference voltage. Higher reference voltage levels may be applied with reduced accuracy requirements.

(4) The accuracy requirements limit the minimum external differential reference voltage. Lower differential reference voltage levels may be applied with reduced accuracy requirements.

5.25 12-Bit ADC, Built-In Reference

over recommended operating supply voltage and free-air temperature (unless otherwise noted)

PARAMETER	TEST CONDITIONS	V _{CC}	MIN	TYP	MAX	UNIT	
V _{REF+}	REF2_5V = 1 for 2.5 V, I _{VREF+} ≤ I _{VREF+(max)}	3 V	2.4	2.5	2.6	V	
	REF2_5V = 0 for 1.5 V, I _{VREF+} ≤ I _{VREF+(max)}	2.2 V, 3 V	1.44	1.5	1.56		
AV _{CC(min)}	REF2_5V = 0, I _{VREF+} ≤ 1 mA		2.2			V	
	REF2_5V = 1, I _{VREF+} ≤ 0.5 mA		V _{REF+} + 0.15				
	REF2_5V = 1, I _{VREF+} ≤ 1 mA		V _{REF+} + 0.15				
I _{VREF+}	Load current out of V _{REF+} terminal	2.2 V	0.01		-0.5	mA	
		3 V			-1		
I _{L(VREF+)}	Load-current regulation, V _{REF+} terminal ⁽¹⁾	I _{VREF+} = 500 μA ±100 μA, Analog input voltage ≈ 0.75 V, REF2_5V = 0	2.2 V			±2	LSB
			3 V			±2	
		I _{VREF+} = 500 μA ±100 μA, Analog input voltage ≈ 1.25 V, REF2_5V = 1	3 V			±2	LSB
I _{DL(VREF+)}	Load-current regulation, VREF+ terminal ⁽²⁾	I _{VREF+} = 100 μA to 90 μA, C _{VREF+} = 5 μF, V _{AX} ≈ 0.5 × V _{REF+} , Error of conversion result ≤ 1 LSB	3 V			20	ns
C _{VREF+}	Capacitance at VREF+ terminal ⁽³⁾	REFON = 1, 0 mA ≤ I _{VREF+} ≤ I _{VREF+(max)}	2.2 V, 3 V	5	10		μF
T _{REF+}	Temperature coefficient of built-in reference ⁽¹⁾	I _{VREF+} is constant in the range of 0 mA ≤ I _{VREF+} ≤ 1 mA	2.2 V, 3 V			±100	ppm/°C
t _{REFON}	Settling time of reference voltage ⁽⁴⁾⁽¹⁾ (see Figure 5-13)	I _{VREF+} = 0.5 mA, C _{VREF+} = 10 μF, V _{VREF+} = 1.5 V, V _{AVCC} = 2.2 V				17	ms

(1) Not production tested, limits characterized

(2) Not production tested, limits verified by design

(3) The internal buffer operational amplifier and the accuracy specifications require an external capacitor. All INL and DNL tests uses two capacitors between pins VREF+ and AV_{SS} and VREF-/VREF- and AV_{SS}: 10-μF tantalum and 100-nF ceramic.

(4) The condition is that the error in a conversion started after t_{REFON} is less than ±0.5 LSB. The settling time depends on the external capacitive load.

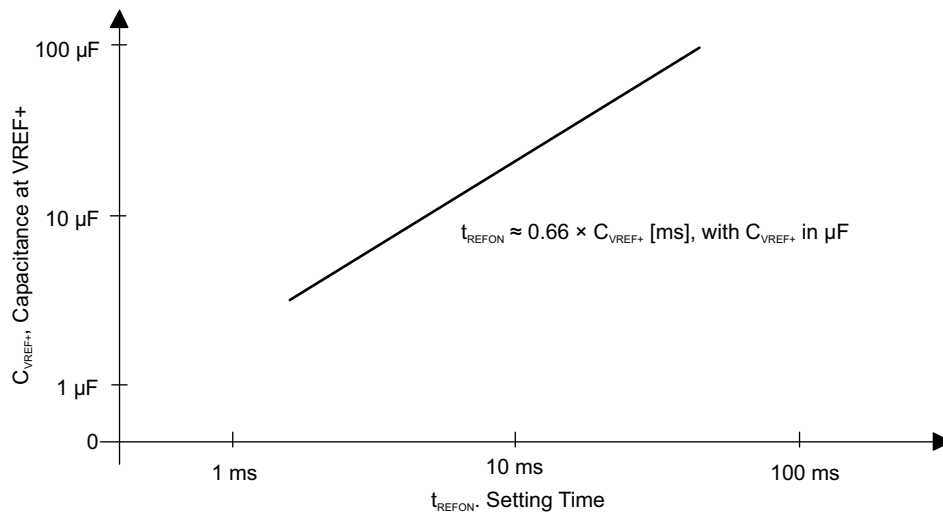

Figure 5-13. Typical Settling Time of Internal Reference (t_{REFON}) vs External Capacitor on VREF+



Figure 5-14. Supply Voltage and Reference Voltage Design, V_{REF}–/V_{eREF}– External Supply



Figure 5-15. Supply Voltage and Reference Voltage Design, VREF-/VeREF- = AVSS, Internally Connected

5.26 12-Bit ADC, Timing Parameters

over recommended operating supply voltage and free-air temperature (unless otherwise noted)

PARAMETER		TEST CONDITIONS	V _{CC}	MIN	TYP	MAX	UNIT
f _{ADC12CLK}	ADC clock frequency	For specified performance of ADC12 linearity parameters	2.2 V, 3 V	0.45	5	6.3	MHz
f _{ADC12OSC}	Internal ADC12 oscillator	ADC12DIV = 0, f _{ADC12CLK} = f _{ADC12OSC}	2.2 V, 3 V	3.7		6.3	MHz
t _{CONVERT}	Conversion time	C _{VREF+} ≥ 5 μF, internal oscillator, f _{ADC12OSC} = 3.7 MHz to 6.3 MHz External f _{ADC12CLK} from ACLK, MCLK or SMCLK, ADC12SSEL ≠ 0	2.2 V, 3 V	2.06		3.51	μs
t _{ADC12ON}	Turn-on settling time of the ADC ⁽¹⁾	See ⁽²⁾				100	ns
t _{Sample}	Sampling time ⁽¹⁾	R _S = 400 Ω, R _I = 1000 Ω, C _I = 30 pF, τ = [R _S + R _I] × C _I ⁽³⁾	3 V 2.2 V	1220 1400			ns

(1) Not production tested, limits verified by design

(2) The condition is that the error in a conversion started after t_{ADC12ON} is less than ±0.5 LSB. The reference and input signal are already settled.

(3) Approximately 10 Tau (τ) are needed to get an error of less than ±0.5 LSB:

$$t_{\text{Sample}} = \ln(2^{n+1}) \times (R_S + R_I) \times C_I + 800 \text{ ns, where } n = \text{ADC resolution} = 12, R_S = \text{external source resistance}$$

5.27 12-Bit ADC, Linearity Parameters

over recommended operating supply voltage and free-air temperature (unless otherwise noted)

PARAMETER		TEST CONDITIONS	V _{CC}	MIN	TYP	MAX	UNIT
E _I	Integral linearity error	1.4 V ≤ (V _{VeREF+} - V _{VREF-/VeREF-}) _{min} ≤ 1.6 V	2.2 V, 3 V			±2	LSB
		1.6 V < (V _{VeREF+} - V _{VREF-/VeREF-}) _{min} ≤ V _{AVCC}				±1.7	
E _D	Differential linearity error	(V _{VeREF+} - V _{VREF-/VeREF-}) _{min} ≤ (V _{VeREF+} - V _{VREF-/VeREF-}), C _{VREF+} = 10 μF (tantalum) and 100 nF (ceramic)	2.2 V, 3 V			±1	LSB
E _O	Offset error	(V _{VeREF+} - V _{VREF-/VeREF-}) _{min} ≤ (V _{VeREF+} - V _{VREF-/VeREF-}), Internal impedance of source R _S < 100 Ω, C _{VREF+} = 10 μF (tantalum) and 100 nF (ceramic)	2.2 V, 3 V		±2	±4	LSB
E _G	Gain error	(V _{VeREF+} - V _{VREF-/VeREF-}) _{min} ≤ (V _{VeREF+} - V _{VREF-/VeREF-}), C _{VREF+} = 10 μF (tantalum) and 100 nF (ceramic)	2.2 V, 3 V		±1.1	±2	LSB
E _T	Total unadjusted error	(V _{VeREF+} - V _{VREF-/VeREF-}) _{min} ≤ (V _{VeREF+} - V _{VREF-/VeREF-}), C _{VREF+} = 10 μF (tantalum) and 100 nF (ceramic)	2.2 V, 3 V		±2	±5	LSB

5.28 12-Bit ADC, Temperature Sensor and Built-In V_{MID}

over recommended operating supply voltage and free-air temperature (unless otherwise noted)

PARAMETER		TEST CONDITIONS	V_{CC}	MIN	TYP	MAX	UNIT
I_{SENSOR}	Operating supply current into AV_{CC} terminal ⁽¹⁾	REFON = 0, INCH = 0Ah, ADC12ON = N/A, $T_A = 25^\circ C$	2.2 V		40	120	μA
			3 V		60	160	
V_{SENSOR}	Sensor output voltage ⁽²⁾	ADC12ON = 1, INCH = 0Ah, $T_A = 0^\circ C$	2.2 V		986	986 $\pm 5\%$	mV
			3 V		986	986 $\pm 5\%$	
TC_{SENSOR}	Temperature coefficient of sensor output voltage ⁽²⁾	ADC12ON = 1, INCH = 0Ah	2.2 V		3.55	3.55 $\pm 3\%$	mV/ $^\circ C$
			3 V		3.55	3.55 $\pm 3\%$	
$t_{SENSOR(sample)}$	Sample time required if channel 10 is selected ⁽²⁾⁽³⁾	ADC12ON = 1, INCH = 0Ah, Error of conversion result ≤ 1 LSB	2.2 V		30		μs
			3 V		30		
I_{VMID}	Current into divider at channel 11 ⁽⁴⁾	ADC12ON = 1, INCH = 0Bh	2.2 V			N/A ⁽⁵⁾	μA
			3 V			N/A	
V_{MID}	AV_{CC} divider at channel 11	ADC12ON = 1, INCH = 0Bh, $V_{MID} \approx 0.5 \times V_{AVCC}$	2.2 V		1.1	1.1 ± 0.04	V
			3 V		1.5	1.5 ± 0.04	
$t_{VMID(sample)}$	Sample time required if channel 11 is selected ⁽⁶⁾	ADC12ON = 1, INCH = 0Bh, Error of conversion result ≤ 1 LSB	2.2 V		1400		ns
			3 V		1220		

(1) The sensor current I_{SENSOR} is consumed if (ADC12ON = 1 and REFON = 1), or (ADC12ON = 1 AND INCH = 0Ah and sample signal is high). Therefore, it includes the constant current through the sensor and the reference.

(2) Not production tested, limits characterized

(3) The typical equivalent impedance of the sensor is 51 k Ω . The sample time required includes the sensor on-time, $t_{SENSOR(on)}$.

(4) No additional current is needed. The V_{MID} is used during sampling.

(5) N/A = Not applicable

(6) The on-time $t_{VMID(on)}$ is included in the sampling time $t_{VMID(sample)}$; no additional on time is needed.

5.29 Flash Memory

over recommended operating supply voltage and free-air temperature (unless otherwise noted)

PARAMETER		TEST CONDITIONS	MIN	TYP	MAX	UNIT
$V_{CC(PGM/ERASE)}$	Program and erase supply voltage		2.7		3.6	V
f_{FTG}	Flash timing generator frequency		257		476	kHz
I_{PGM}	Supply current from DV_{CC} during program	$V_{CC} = 2.7$ V or 3.6 V		3	5	mA
I_{ERASE}	Supply current from DV_{CC} during erase	$V_{CC} = 2.7$ V or 3.6 V		3	7	mA
t_{CPT}	Cumulative program time ⁽¹⁾	$V_{CC} = 2.7$ V or 3.6 V			4	ms
$t_{CMErase}$	Cumulative mass erase time ⁽²⁾	$V_{CC} = 2.7$ V or 3.6 V	200			ms
	Program and erase endurance ⁽³⁾		10^4	10^5		cycles
$t_{Retention}$	Data retention duration ⁽³⁾	$T_J = 25^\circ C$	100			years
t_{Word}	Word or byte program time ⁽³⁾			35		t_{FTG}
$t_{Block, 0}$	Block program time for first byte or word ⁽³⁾			30		t_{FTG}
$t_{Block, 1-63}$	Block program time for each additional byte or word ⁽³⁾			21		t_{FTG}
$t_{Block, End}$	Block program end-sequence wait time ⁽³⁾			6		t_{FTG}
$t_{Mass Erase}$	Mass erase time ⁽³⁾			5297		t_{FTG}
$t_{Seg Erase}$	Segment erase time ⁽³⁾			4819		t_{FTG}

(1) The cumulative program time must not be exceeded when writing to a 64-byte flash block. This parameter applies to all programming methods: individual word or byte write and block write modes.

(2) The mass erase duration generated by the flash timing generator is at least 11.1 ms ($= 5297 \times 1/f_{FTG}$, maximum = $5297 \times 1/476$ kHz). To achieve the required cumulative mass erase time the flash controller mass erase operation can be repeated until this time is met. A worst case minimum of 19 cycles are required.

(3) These values are hardwired into the flash controller state machine ($t_{FTG} = 1/f_{FTG}$).

5.30 JTAG Interface

over recommended operating supply voltage and free-air temperature (unless otherwise noted)

PARAMETER		V _{CC}	MIN	TYP	MAX	UNIT
f _{TCK}	TCK input frequency ⁽¹⁾	2.2 V	0		5	MHz
		3 V	0		10	
R _{internal}	Internal pullup resistance on TMS, TCK, TDI/TCLK	2.2 V, 3 V	25	60	90	kΩ

(1) f_{TCK} may be restricted to meet the timing requirements of the module selected.

5.31 JTAG Fuse ⁽¹⁾

over recommended operating supply voltage and free-air temperature (unless otherwise noted)

PARAMETER		T _A	MIN	MAX	UNIT
V _{CC(FB)}	Supply voltage during fuse blow	25°C	2.5		V
V _{FB}	Voltage level on TDI/TCLK for fuse blow		6	7	V
I _{FB}	Supply current into TDI/TCLK during fuse blow			100	mA
t _{FB}	Time to blow fuse			1	ms

(1) After the fuse is blown, no further access to the MSP430 JTAG/Test and emulation features is possible. The JTAG block is switched to bypass mode.

6 Detailed Description

6.1 CPU

The MSP430 CPU has a 16-bit RISC architecture that is highly transparent to the application. All operations, other than program-flow instructions, are performed as register operations in conjunction with seven addressing modes for source operand and four addressing modes for destination operand.

The CPU is integrated with 16 registers that provide reduced instruction execution time. The register-to-register operation execution time is one cycle of the CPU clock. Four of the registers, R0 to R3, are dedicated as program counter, stack pointer, status register, and constant generator, respectively. The remaining registers are general-purpose registers (see [Figure 6-1](#)).

Peripherals are connected to the CPU using data, address, and control buses, and can be handled with all instructions.

The instruction set consists of the original 51 instructions with three formats and seven address modes and additional instructions for the expanded address range. Each instruction can operate on word and byte data.

Program Counter	PC/R0
Stack Pointer	SP/R1
Status Register	SR/CG1/R2
Constant Generator	CG2/R3
General-Purpose Register	R4
General-Purpose Register	R5
General-Purpose Register	R6
General-Purpose Register	R7
General-Purpose Register	R8
General-Purpose Register	R9
General-Purpose Register	R10
General-Purpose Register	R11
General-Purpose Register	R12
General-Purpose Register	R13
General-Purpose Register	R14
General-Purpose Register	R15

Figure 6-1. CPU Registers

6.2 Instruction set

The instruction set consists of 51 instructions with three formats and seven address modes. Each instruction can operate on word and byte data. [Table 6-1](#) lists examples of the three types of instruction formats, and [Table 6-2](#) lists the address modes.

Table 6-1. Instruction Word Formats

INSTRUCTION FORMAT	EXAMPLE	OPERATION
Dual operands, source-destination	ADD R4, R5	R4 + R5 → R5
Single operands, destination only	CALL R8	PC → (TOS), R8 → PC
Relative jump, unconditional or conditional	JNE	Jump-on-equal bit = 0

Table 6-2. Address Mode Descriptions

ADDRESS MODE	S ⁽¹⁾	D ⁽¹⁾	SYNTAX	EXAMPLE	OPERATION
Register	✓	✓	MOV Rs, Rd	MOV R10, R11	R10 → R11
Indexed	✓	✓	MOV X(Rn), Y(Rm)	MOV 2(R5), 6(R6)	M(2+R5) → M(6+R6)
Symbolic (PC relative)	✓	✓	MOV EDE, TONI		M(EDE) → M(TONI)
Absolute	✓	✓	MOV &MEM, &TCDAT		M(MEM) → M(TCDAT)
Indirect	✓		MOV @Rn, Y(Rm)	MOV @R10, Tab(R6)	M(R10) → M(Tab+R6)
Indirect autoincrement	✓		MOV @Rn+, Rm	MOV @R10+, R11	M(R10) → R11 R10 + 2 → R10
Immediate	✓		MOV #X, TONI	MOV #45, TONI	#45 → M(TONI)

(1) S = source, D = destination

6.3 Operating Modes

The MSP430F13x, MSP430F14x, and MSP430F14x1 MCUs support one active mode and five software-selectable low-power modes of operation. An interrupt event can wake up the MCU from any of the low-power modes, service the request, and restore back to the low-power mode on return from the interrupt program.

The following operating modes can be configured by software:

- Active mode (AM)
 - All clocks are active
- Low-power mode 0 (LPM0)
 - CPU is disabled
 - ACLK and SMCLK remain active
 - MCLK is disabled
- Low-power mode 1 (LPM1)
 - CPU is disabled
 - ACLK and SMCLK remain active
 - MCLK is disabled
 - DC generator of the DCO is disabled if DCO not used in active mode
- Low-power mode 2 (LPM2)
 - CPU is disabled
 - MCLK and SMCLK are disabled
 - DC generator of the DCO remains enabled
 - ACLK remains active
- Low-power mode 3 (LPM3)
 - CPU is disabled
 - MCLK and SMCLK are disabled
 - DC generator of the DCO is disabled
 - ACLK remains active
- Low-power mode 4 (LPM4)
 - CPU is disabled
 - ACLK is disabled
 - MCLK and SMCLK are disabled
 - DC generator of the DCO is disabled
 - Crystal oscillator is stopped

6.4 Interrupt Vector Addresses

The interrupt vectors and the power-up starting address are in the address range 0FFFFh to 0FFE0h. The vector contains the 16-bit address of the appropriate interrupt-handler instruction sequence.

Table 6-3. Interrupt Sources, Flags, and Vectors

INTERRUPT SOURCE	INTERRUPT FLAG	SYSTEM INTERRUPT	WORD ADDRESS	PRIORITY
Power up External reset Watchdog Flash memory	WDTIFG KEYV ⁽¹⁾	Reset	0FFFEh	15, highest
NMI Oscillator fault Flash memory access violation	NMIIFG OFIFG ACCVIFG ⁽¹⁾	(Non)maskable ⁽²⁾	0FFFCh	14
Timer_B7 ⁽³⁾	TBCCR0 CCIFG ⁽⁴⁾	Maskable	0FFFAh	13
Timer_B7 ⁽³⁾	TBCCR1 to 6 CCIFGs, TBIFG ⁽¹⁾⁽⁴⁾	Maskable	0FFF8h	12
Comparator_A	CAIFG	Maskable	0FFF9h	11
Watchdog timer	WDTIFG	Maskable	0FFF4h	10
USART0 receive	URXIFG0	Maskable	0FFF2h	9
USART0 transmit	UTXIFG0	Maskable	0FFF0h	8
ADC12 ⁽⁵⁾	ADC12IFG ⁽¹⁾⁽⁴⁾	Maskable	0FFEEh	7
Timer_A3	TACCR0 CCIFG ⁽⁴⁾	Maskable	0FFECCh	6
Timer_A3	TACCR1 CCIFG, TACCR2 CCIFG, TAIFG ⁽¹⁾⁽⁴⁾	Maskable	0FFEAh	5
I/O port P1 (eight flags)	P1IFG.0 to P1IFG.7 ⁽¹⁾⁽⁴⁾	Maskable	0FFE8h	4
USART1 receive	URXIFG1	Maskable	0FFE6h	3
USART1 transmit	UTXIFG1	Maskable	0FFE4h	2
I/O port P2 (eight flags)	P2IFG.0 to P2IFG.7 ⁽¹⁾⁽⁴⁾	Maskable	0FFE2h	1
–	–	–	0FFE0h	0, lowest

(1) Multiple source flags

(2) (Non)maskable: the individual interrupt-enable bit can disable an interrupt event, but the general-interrupt enable can not disable it.

(3) Timer_B7 in the MSP430F14x(1) MCUs has 7 CCRs, and Timer_B3 in the MSP430F13x MCUs has 3 CCRs. In Timer_B3, there are only interrupt flags TBCCR0, TBCCR1, and TBCCR2 CCIFGs and the interrupt-enable bits TBCCTL0, TBCCTL1, and TBCCTL2 CCIEs.

(4) Interrupt flags are located in the module.

(5) ADC12 is not implemented on the MSP430F14x1 devices.

6.5 Bootloader (BSL)

The MSP430 BSL lets users program the flash memory or RAM using a UART serial interface. Access to the MSP430 memory through the BSL is protected by a user-defined password. For complete description of the features of the BSL and its implementation, see the [MSP430™ Flash Device Bootloader \(BSL\) User's Guide](#). [Table 6-4](#) lists the pin requirements for the BSL.

Table 6-4. BSL Pin Requirements and Functions

BSL FUNCTION	PM, PAG, AND RTD PACKAGE PINS
Data transmit	13 - P1.1
Data receive	22 - P2.2

6.6 JTAG Fuse Check Mode

MSP430 MCUs that have the fuse on the TDI/TCLK terminal have a fuse check mode that tests the continuity of the fuse the first time the JTAG port is accessed after a power-on reset (POR). When activated, a fuse check current (I_{TF}) of 1 mA at 3 V or 2.5 mA at 5 V can flow from the TDI/TCLK pin to ground if the fuse is not burned. Care must be taken to avoid accidentally activating the fuse check mode and increasing overall system power consumption.

Activation of the fuse check mode occurs with the first negative edge on the TMS pin after power up or if the TMS is being held low during power up. The second positive edge on the TMS pin deactivates the fuse check mode. After deactivation, the fuse check mode remains inactive until another POR occurs. After each POR the fuse check mode has the potential to be activated.

The fuse check current flows only when the fuse check mode is active and the TMS pin is in a low state (see Figure 6-2). Therefore, the additional current flow can be prevented by holding the TMS pin high (default condition).



Figure 6-2. Fuse Check Mode Current

6.7 Memory

Table 6-5 summarizes the memory map of all device variants.

Table 6-5. Memory Organization

		MSP430F133	MSP430F135	MSP430F147 MSP430F1471	MSP430F148 MSP430F1481	MSP430F149 MSP430F149
Memory (flash)	Size	8KB	16KB	32KB	48KB	60KB
Main: interrupt vector	Flash	0FFFFh to 0FFE0h	0FFFFh to 0FFE0h	0FFFFh to 0FFE0h	0FFFFh to 0FFE0h	0FFFFh to 0FFE0h
Main: code memory	Flash	0FFFFh to 0E000h	0FFFFh to 0C000h	0FFFFh to 08000h	0FFFFh to 04000h	0FFFFh to 01100h
Information memory	Size	256 bytes	256 bytes	256 bytes	256 bytes	256 bytes
	Flash	010FFh to 01000h	010FFh to 01000h	010FFh to 01000h	010FFh to 01000h	010FFh to 01000h
Boot memory	Size	1KB	1KB	1KB	1KB	1KB
	Flash	0FFFh to 0C00h	0FFFh to 0C00h	0FFFh to 0C00h	0FFFh to 0C00h	0FFFh to 0C00h
RAM	Size	256 bytes	512 bytes	1KB	2KB	2KB
	RAM	02FFh to 0200h	03FFh to 0200h	05FFh to 0200h	09FFh to 0200h	09FFh to 0200h
Peripherals	16-bit	01FFh to 0100h	01FFh to 0100h	01FFh to 0100h	01FFh to 0100h	01FFh to 0100h
	8-bit	0FFh to 010h	0FFh to 010h	0FFh to 010h	0FFh to 010h	0FFh to 010h
	8-bit SFR	0Fh to 00h	0Fh to 00h	0Fh to 00h	0Fh to 00h	0Fh to 00h

6.7.1 Flash Memory

The flash memory can be programmed through the JTAG port, the bootloader, or in-system by the CPU. The CPU can perform single-byte and single-word writes to the flash memory. Features of the flash memory include:

- Flash memory has n segments of main memory and two segments of information memory (A and B) of 128 bytes each. Each segment in main memory is 512 bytes in size.
- Segments 0 to n may be erased in one step, or each segment may be individually erased.
- Segments A and B can be erased individually, or as a group with segments 0 to n. Segments A and B are also called *information memory*.
- New devices may have some bytes programmed in the information memory (needed for test during manufacturing). The user should perform an erase of the information memory prior to the first use.

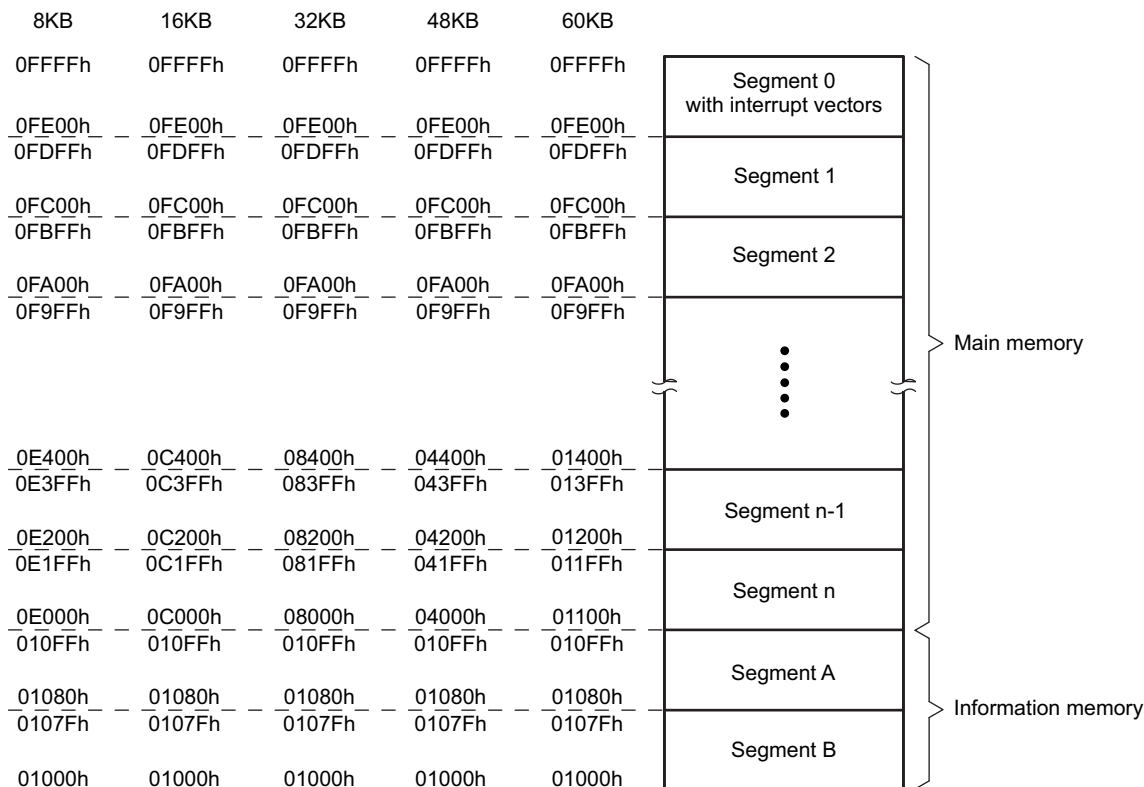

Figure 6-3. Flash Memory

6.7.2 Special Function Registers

Most interrupt and module-enable bits are collected in the lowest address space. Special-function register bits not allocated to a functional purpose are not physically present in the device. This arrangement provides simple software access.

Figure 6-4. Interrupt Enable 1 Bit Register

7	6	5	4	3	2	1	0
UTXIE0	URXIE0	ACCVIE	NMIIE	Reserved		OFIE	WDTIE
R/W-0	R/W-0	R/W-0	R/W-0	R-0		R/W-0	R/W-0

Table 6-6. Interrupt Enable 1 Register Field Descriptions

Bit	Field	Type	Reset	Description
7	UTXIE0	R/W	0	USART0: UART and SPI transmit interrupt enable
6	URXIE0	R/W	0	USART0: UART and SPI receive interrupt enable
5	ACCVIE	R/W	0	Flash access violation interrupt enable
4	NMIIE	R/W	0	Nonmaskable interrupt enable
3-2	Reserved	R	0	
1	OFIE	R/W	0	Oscillator-fault interrupt enable
0	WDTIE	R/W	0	Watchdog timer interrupt enable. Inactive if watchdog mode is selected. Active if watchdog timer is configured in interval timer mode.

Figure 6-5. Interrupt Enable 2 Bit Register

7	6	5	4	3	2	1	0
Reserved		UTXIE1	URXIE1	Reserved			
R-0		R/W-0	R/W-0	R-0			

Table 6-7. Interrupt Enable 2 Register Field Descriptions

Bit	Field	Type	Reset	Description
7-6	Reserved	R	0	
5	UTXIE1	R/W	0	USART1: UART and SPI receive interrupt enable
4	URXIE1	R/W	0	USART1: UART and SPI transmit interrupt enable
3-0	Reserved	R/W	0	

Figure 6-6. Interrupt Flag 1 Bit Register

7	6	5	4	3	2	1	0
UTXIFG0	URXIFG0	Reserved	NMIIFG	Reserved		OFIFG	WDTIFG
R/W-1	R/W-0	R-0	R/W-0	R-0		R/W-1	R/W-(0)

Table 6-8. Interrupt Flag 1 Register Field Descriptions

Bit	Field	Type	Reset	Description
7	UTXIFG0	R/W	1	USART0: UART and SPI transmit flag
6	URXIFG0	R/W	0	USART0: UART and SPI receive flag
5	Reserved	R	0	
4	NMIIFG	R/W	0	Set by $\overline{\text{RST}}$ /NMI pin
3-2	Reserved	R	0	
1	OFIFG	R/W	1	Flag set on oscillator fault
0	WDTIFG	R/W	(0)	Set on watchdog timer overflow (in watchdog mode) or security key violation. Reset on V_{CC} power up or a reset condition at the $\overline{\text{RST}}$ /NMI pin in reset mode.

Figure 6-7. Interrupt Flag 2 Bit Register

7	6	5	4	3	2	1	0
Reserved		UTXIFG1	URXIFG1	Reserved			
R-0		R/W-1	R/W-0	R-0			

Table 6-9. Interrupt Flag 2 Register Field Descriptions

Bit	Field	Type	Reset	Description
7-6	Reserved	R	0	
5	UTXIFG1	R/W	1	USART1: UART and SPI transmit flag
4	URXIFG1	R/W	0	USART1: UART and SPI receive flag
3-0	Reserved	R	0	

Figure 6-8. Module Enable 1 Bit Register

7	6	5	4	3	2	1	0
UTXE0	URXE0 USPIE0	Reserved					
R/W-0	R/W-0	R-0					

Table 6-10. Module Enable 1 Bit Register Field Descriptions

Bit	Field	Type	Reset	Description
7	UTXE0	R/W	0	USART0: UART transmit enable
6	URXE0 USPIE0	R/W	0	USART0: UART receive enable USART0: SPI (synchronous peripheral interface) transmit and receive enable
5-0	Reserved	R	0	

Figure 6-9. Module Enable 2 Bit Register

7	6	5	4	3	2	1	0
Reserved		UTXE1	URXE1 USPIE1	Reserved			
R-0		R/W-0	R/W-0	R-0			

Table 6-11. Module Enable 2 Bit Register Field Descriptions

Bit	Field	Type	Reset	Description
7-6	Reserved	R	0	
5		R/W	0	USART1: UART transmit enable
4	URXE1 USPIE1	R/W	0	USART1: UART receive enable USART1: SPI (synchronous peripheral interface) transmit and receive enable
3-0	Reserved	R	0	

6.8 Peripherals

Peripherals are connected to the CPU through data, address, and control buses and can be handled using all instructions. For complete module descriptions, see the [MSP430x1xx Family User's Guide](#).

6.8.1 Digital I/O

Six 8-bit I/O ports are implemented: ports P1 to P6:

- All individual I/O bits are independently programmable.
- Any combination of input, output, and interrupt conditions is possible.
- Edge-selectable interrupt input capability for all the eight bits of ports P1 and P2.
- Read and write access to port-control registers is supported by all instructions.

6.8.2 Oscillator and System Clock

The clock system is supported by the basic clock module that includes support for a 32768-Hz watch crystal oscillator, an internal digitally controlled oscillator (DCO), and a high-frequency crystal oscillator. The basic clock module is designed to meet the requirements of both low system cost and low power consumption. The internal DCO provides a fast turn-on clock source and stabilizes in less than 6 μ s. The basic clock module provides the following clock signals:

- Auxiliary clock (ACLK), sourced from a 32768-Hz watch crystal or a high-frequency crystal
- Main clock (MCLK), the system clock used by the CPU
- Sub-Main clock (SMCLK), the subsystem clock used by the peripheral modules

6.8.3 Watchdog Timer (WDT)

The primary function of the WDT module is to perform a controlled system restart after a software problem occurs. If the selected time interval expires, a system reset is generated. If the watchdog function is not needed in an application, the module can be configured as an interval timer and can generate interrupts at selected time intervals.

6.8.4 Hardware Multiplier (MSP430F14x and MSP430F14x1 Only)

The multiplication operation is supported by a dedicated peripheral module. The module performs 16×16 , 16×8 , 8×16 , and 8×8 bit operations. The module is capable of supporting signed and unsigned multiplication as well as signed and unsigned multiply and accumulate operations. The result of an operation can be accessed immediately after the operands have been loaded into the peripheral registers. No additional clock cycles are required.

6.8.5 USART0

The hardware universal synchronous/asynchronous receive transmit (USART0) peripheral module is used for serial data communication. The USART supports synchronous SPI (3 or 4 pin) and asynchronous UART communication protocols, using double-buffered transmit and receive channels.

6.8.6 USART1 (MSP430F14x and MSP430F14x1 Only)

The MSP430F14x(1) has a second hardware universal synchronous/asynchronous receive transmit (USART1) peripheral module that is used for serial data communication. The USART supports synchronous SPI (3 or 4 pin) and asynchronous UART communication protocols, using double-buffered transmit and receive channels. Operation of USART1 is identical to USART0.

6.8.7 Comparator_A

The primary function of the Comparator_A module is to support precision slope analog-to-digital conversions, battery-voltage supervision, and monitoring of external analog signals.

6.8.8 ADC12 (MSP430F14x and MSP430F13x Only)

The ADC12 module supports fast 12-bit analog-to-digital conversions. The module implements a 12-bit SAR core, sample select control, reference generator, and a 16-word conversion-and-control buffer. The conversion-and-control buffer allows up to 16 independent ADC samples to be converted and stored without CPU intervention.

6.8.9 Timer_A3

Timer_A3 is a 16-bit timer/counter with three capture/compare registers. Timer_A3 can support multiple capture/compares, PWM outputs, and interval timing (see [Table 6-12](#)). Timer_A3 also has extensive interrupt capabilities. Interrupts may be generated from the counter on overflow conditions and from each of the capture/compare registers.

Table 6-12. Timer_A3 Signal Connections

INPUT PIN NUMBER	DEVICE INPUT SIGNAL	MODULE INPUT NAME	MODULE BLOCK	MODULE OUTPUT SIGNAL	OUTPUT PIN NUMBER
12 - P1.0	TACLK	TACLK	Timer	NA	
	ACLK	ACLK			
	SMCLK	SMCLK			
21 - P2.1	TAINCLK	INCLK			
13 - P1.1	TA0	CCI0A	CCR0	TA0	13 - P1.1
22 - P2.2	TA0	CCI0B			17 - P1.5
	DV _{SS}	GND			27 - P2.7
	DV _{CC}	VCC			
14 - P1.2	TA1	CCI1A	CCR1	TA1	
	CAOUT (internal)	CCI1B			
	DV _{SS}	GND			
	DV _{CC}	VCC			
15 - P1.3	TA2	CCI2A	CCR2	TA2	
	ACLK (internal)	CCI2B			
	DV _{SS}	GND			
	DV _{CC}	VCC			

6.8.10 Timer_B3 (MSP430F13x Only)

Timer_B3 is a 16-bit timer/counter with three capture/compare registers. Timer_B3 can support multiple capture/compares, PWM outputs, and interval timing (see [Table 6-13](#)). Timer_B3 also has extensive interrupt capabilities. Interrupts may be generated from the counter on overflow conditions and from each of the capture/compare registers.

6.8.11 Timer_B7 (MSP430F14x and MSP430F14x1 Only)

Timer_B7 is a 16-bit timer/counter with seven capture/compare registers. Timer_B7 can support multiple capture/compares, PWM outputs, and interval timing (see [Table 6-13](#)). Timer_B7 also has extensive interrupt capabilities. Interrupts may be generated from the counter on overflow conditions and from each of the capture/compare registers.

Table 6-13. Timer_B3 and Timer_B7 Signal Connections⁽¹⁾

INPUT PIN NUMBER	DEVICE INPUT SIGNAL	MODULE INPUT NAME	MODULE BLOCK	MODULE OUTPUT SIGNAL	OUTPUT PIN NUMBER
43 - P4.7	TBCLK	TBCLK	Timer	NA	
	ACLK	ACLK			
	SMCLK	SMCLK			
43 - P4.7	TBCLK	INCLK			
36 - P4.0	TB0	CCI0A	CCR0	TB0	36 - P4.0
36 - P4.0	TB0	CCI0B			ADC12 (internal)
	DV _{SS}	GND			
	DV _{CC}	VCC			
37 - P4.1	TB1	CCI1A	CCR1	TB1	37 - P4.1
37 - P4.1	TB1	CCI1B			ADC12 (internal)
	DV _{SS}	GND			
	DV _{CC}	V _{CC}			
38 - P4.2	TB2	CCI2A	CCR2	TB2	38 - P4.2
38 - P4.2	TB2	CCI2B			
	DV _{SS}	GND			
	DV _{CC}	V _{CC}			
39 - P4.3	TB3	CCI3A	CCR3	TB3	39 - P4.3
39 - P4.3	TB3	CCI3B			
	DV _{SS}	GND			
	DV _{CC}	V _{CC}			
40 - P4.4	TB4	CCI4A	CCR4	TB4	40 - P4.4
40 - P4.4	TB4	CCI4B			
	DV _{SS}	GND			
	DV _{CC}	V _{CC}			
41 - P4.5	TB5	CCI5A	CCR5	TB5	41 - P4.5
41 - P4.5	TB5	CCI5B			
	DV _{SS}	GND			
	DV _{CC}	V _{CC}			
42 - P4.6	TB6	CCI6A	CCR6	TB6	42 - P4.6
	ACLK (internal)	CCI6B			
	DV _{SS}	GND			
	DV _{CC}	V _{CC}			

(1) Timer_B3 implements three capture/compare blocks (CCR0, CCR1 and CCR2).

6.8.12 Peripheral File Map

Table 6-14 lists the peripheral register that support word access. See Table 6-15 for the registers with byte access.

Table 6-14. Peripherals With Word Access

MODULE	REGISTER NAME	ACRONYM	ADDRESS
Watchdog	Watchdog timer control	WDTCTL	0120h
Timer_B7, Timer_B3	Timer_B interrupt vector	TBIV	011Eh
	Timer_B control	TBCTL	0180h
	Timer_B capture/compare control 0	TBCCTL0	0182h
	Timer_B capture/compare control 1	TBCCTL1	0184h
	Timer_B capture/compare control 2	TBCCTL2	0186h
	Timer_B capture/compare control 3 ⁽¹⁾	TBCCTL3	0188h
	Timer_B capture/compare control 4 ⁽¹⁾	TBCCTL4	018Ah
	Timer_B capture/compare control 5 ⁽¹⁾	TBCCTL5	018Ch
	Timer_B capture/compare control 6 ⁽¹⁾	TBCCTL6	018Eh
	Timer_B counter	TBR	0190h
	Timer_B capture/compare 0	TBCCR0	0192h
	Timer_B capture/compare 1	TBCCR1	0194h
	Timer_B capture/compare 2	TBCCR2	0196h
	Timer_B capture/compare 3 ⁽¹⁾	TBCCR3	0198h
	Timer_B capture/compare 4 ⁽¹⁾	TBCCR4	019Ah
	Timer_B capture/compare 5 ⁽¹⁾	TBCCR5	019Ch
	Timer_B capture/compare 6 ⁽¹⁾	TBCCR6	019Eh
Timer_A3	Timer_A interrupt vector	TAIV	012Eh
	Timer_A control	TACTL	0160h
	Timer_A capture/compare control 0	TACCTL0	0162h
	Timer_A capture/compare control 1	TACCTL1	0164h
	Timer_A capture/compare control 2	TACCTL2	0166h
	Reserved		0168h
	Reserved		016Ah
	Reserved		016Ch
	Reserved		016Eh
	Timer_A counter	TAR	0170h
	Timer_A capture/compare 0	TACCR0	0172h
	Timer_A capture/compare 1	TACCR1	0174h
	Timer_A capture/compare 2	TACCR2	0176h
	Reserved		0178h
	Reserved		017Ah
	Reserved		017Ch
	Reserved		017Eh

(1) Timer_B7 only, reserved for Timer_B3

Table 6-14. Peripherals With Word Access (continued)

MODULE	REGISTER NAME	ACRONYM	ADDRESS
Hardware multiplier (MSP430F14x and MSP430F14x1 only)	Sum extend	SUMEXT	013Eh
	Result high word	RESHI	013Ch
	Result low word	RESLO	013Ah
	Operand 2	OP2	0138h
	Multiply signed and accumulate operand 1	MACS	0136h
	Multiply and accumulate operand 1	MAC	0134h
	Multiply signed operand 1	MPYS	0132h
	Multiply unsigned operand 1	MPY	0130h
Flash	Flash control 3	FCTL1	012Ch
	Flash control 2	FCTL2	012Ah
	Flash control 1	FCTL1	0128h

Table 6-14. Peripherals With Word Access (continued)

MODULE	REGISTER NAME	ACRONYM	ADDRESS
ADC12 (not in MSP430F14x1)	Conversion memory 15	ADC12MEM15	015Eh
	Conversion memory 14	ADC12MEM14	015Ch
	Conversion memory 13	ADC12MEM13	015Ah
	Conversion memory 12	ADC12MEM12	0158h
	Conversion memory 11	ADC12MEM11	0156h
	Conversion memory 10	ADC12MEM10	0154h
	Conversion memory 9	ADC12MEM9	0152h
	Conversion memory 8	ADC12MEM8	0150h
	Conversion memory 7	ADC12MEM7	014Eh
	Conversion memory 6	ADC12MEM6	014Ch
	Conversion memory 5	ADC12MEM5	014Ah
	Conversion memory 4	ADC12MEM4	0148h
	Conversion memory 3	ADC12MEM3	0146h
	Conversion memory 2	ADC12MEM2	0144h
	Conversion memory 1	ADC12MEM1	0142h
	Conversion memory 0	ADC12MEM0	0140h
	Interrupt vector word	ADC12IV	01A8h
	Interrupt enable	ADC12IE	01A6h
	Interrupt flag	ADC12IFG	01A4h
	ADC control 1	ADC12CTL1	01A2h
	ADC control 0	ADC12CTL0	01A0h
	ADC memory control 15	ADC12MCTL15	08Fh
	ADC memory control 14	ADC12MCTL14	08Eh
	ADC memory control 13	ADC12MCTL13	08Dh
	ADC memory control 12	ADC12MCTL12	08Ch
	ADC memory control 11	ADC12MCTL11	08Bh
	ADC memory control 10	ADC12MCTL10	08Ah
	ADC memory control 9	ADC12MCTL9	089h
	ADC memory control 8	ADC12MCTL8	088h
	ADC memory control 7	ADC12MCTL7	087h
	ADC memory control 6	ADC12MCTL6	086h
	ADC memory control 5	ADC12MCTL5	085h
	ADC memory control 4	ADC12MCTL4	084h
	ADC memory control 3	ADC12MCTL3	083h
ADC memory control 2	ADC12MCTL2	082h	
ADC memory control 1	ADC12MCTL1	081h	
ADC memory control 0	ADC12MCTL0	080h	

Table 6-15 lists the peripheral register that support byte access. See Table 6-14 for the registers with word access.

Table 6-15. Peripherals With Byte Access

MODULE	REGISTER NAME	ACRONYM	ADDRESS
USART1 (MSP430F14x and MSP430F14x1 only)	Transmit buffer	U1TXBUF	07Fh
	Receive buffer	U1RXBUF	07Eh
	Baud rate 1	U1BR1	07Dh
	Baud rate 0	U1BR0	07Ch
	Modulation control	U1MCTL	07Bh
	Receive control	U1RCTL	07Ah
	Transmit control	U1TCTL	079h
	USART control	U1CTL	078h
USART0	Transmit buffer	U0TXBUF	077h
	Receive buffer	U0RXBUF	076h
	Baud rate 1	U0BR1	075h
	Baud rate 0	U0BR0	074h
	Modulation control	U0MCTL	073h
	Receive control	U0RCTL	072h
	Transmit control	U0TCTL	071h
	USART control	U0CTL	070h
Comparator_A	Comparator_A port disable	CAPD	05Bh
	Comparator_A control 2	CACTL2	05Ah
	Comparator_A control 1	CACTL1	059h
Basic Clock	Basic clock system control 2	BCSCTL2	058h
	Basic clock system control 1	BCSCTL1	057h
	DCO clock frequency control	DCOCTL	056h
Port P6	Port P6 selection	P6SEL	037h
	Port P6 direction	P6DIR	036h
	Port P6 output	P6OUT	035h
	Port P6 input	P6IN	034h
Port P5	Port P5 selection	P5SEL	033h
	Port P5 direction	P5DIR	032h
	Port P5 output	P5OUT	031h
	Port P5 input	P5IN	030h
Port P4	Port P4 selection	P4SEL	01Fh
	Port P4 direction	P4DIR	01Eh
	Port P4 output	P4OUT	01Dh
	Port P4 input	P4IN	01Ch
Port P3	Port P3 selection	P3SEL	01Bh
	Port P3 direction	P3DIR	01Ah
	Port P3 output	P3OUT	019h
	Port P3 input	P3IN	018h

Table 6-15. Peripherals With Byte Access (continued)

MODULE	REGISTER NAME	ACRONYM	ADDRESS
Port P2	Port P2 selection	P2SEL	02Eh
	Port P2 interrupt enable	P2IE	02Dh
	Port P2 interrupt edge select	P2IES	02Ch
	Port P2 interrupt flag	P2IFG	02Bh
	Port P2 direction	P2DIR	02Ah
	Port P2 output	P2OUT	029h
	Port P2 input	P2IN	028h
Port P1	Port P1 selection	P1SEL	026h
	Port P1 interrupt enable	P1IE	025h
	Port P1 interrupt edge select	P1IES	024h
	Port P1 interrupt flag	P1IFG	023h
	Port P1 direction	P1DIR	022h
	Port P1 output	P1OUT	021h
	Port P1 input	P1IN	020h
Special Functions	SFR module enable 2	ME2	005h
	SFR module enable 1	ME1	004h
	SFR interrupt flag 2	IFG2	003h
	SFR interrupt flag 1	IFG1	002h
	SFR interrupt enable 2	IE2	001h
	SFR interrupt enable 1	IE1	000h

6.9 Input/Output Diagrams

6.9.1 Port P1, Input/Output With Schmitt Trigger



Figure 6-10. Port P1 (P1.0 to P1.7) Diagram

Table 6-16. Port P1 (P1.0 to P1.7) Pin Functions

PnSel.x	PnDIR.x	DIRECTION CONTROL FROM MODULE	PnOUT.x	MODULE X OUT	PnIN.x	MODULE X IN	PnIE.x	PnIFG.x	PnIES.x
P1Sel.0	P1DIR.0	P1DIR.0	P1OUT.0	DV _{SS}	P1IN.0	TACLK ⁽¹⁾	P1IE.0	P1IFG.0	P1IES.0
P1Sel.1	P1DIR.1	P1DIR.1	P1OUT.1	Out0 signal ⁽¹⁾	P1IN.1	CCI0A ⁽¹⁾	P1IE.1	P1IFG.1	P1IES.1
P1Sel.2	P1DIR.2	P1DIR.2	P1OUT.2	Out1 signal ⁽¹⁾	P1IN.2	CCI1A ⁽¹⁾	P1IE.2	P1IFG.2	P1IES.2
P1Sel.3	P1DIR.3	P1DIR.3	P1OUT.3	Out2 signal ⁽¹⁾	P1IN.3	CCI2A ⁽¹⁾	P1IE.3	P1IFG.3	P1IES.3
P1Sel.4	P1DIR.4	P1DIR.4	P1OUT.4	SMCLK	P1IN.4	unused	P1IE.4	P1IFG.4	P1IES.4
P1Sel.5	P1DIR.5	P1DIR.5	P1OUT.5	Out0 signal ⁽¹⁾	P1IN.5	unused	P1IE.5	P1IFG.5	P1IES.5
P1Sel.6	P1DIR.6	P1DIR.6	P1OUT.6	Out1 signal ⁽¹⁾	P1IN.6	unused	P1IE.6	P1IFG.6	P1IES.6
P1Sel.7	P1DIR.7	P1DIR.7	P1OUT.7	Out2 signal ⁽¹⁾	P1IN.7	unused	P1IE.7	P1IFG.7	P1IES.7

(1) Signal from or to Timer_A

6.9.2 Port P2, Input/Output With Schmitt Trigger



Figure 6-11. Port P2 (P2.0 to P2.2, P2.6, and P2.7) Diagram

Table 6-17. Port P2 (P2.0 to P2.2, P2.6, and P2.7) Pin Functions

PnSel.x	PnDIR.x	DIRECTION CONTROL FROM MODULE	PnOUT.x	MODULE X OUT	PnIN.x	MODULE X IN	PnIE.x	PnIFG.x	PnIES.x
P2Sel.0	P2DIR.0	P2DIR.0	P2OUT.0	ACLK	P2IN.0	unused	P2IE.0	P2IFG.0	P2IES.0
P2Sel.1	P2DIR.1	P2DIR.1	P2OUT.1	DV _{SS}	P2IN.1	INCLK ⁽¹⁾	P2IE.1	P2IFG.1	P2IES.1
P2Sel.2	P2DIR.2	P2DIR.2	P2OUT.2	CAOUT ⁽²⁾	P2IN.2	CCI0B ⁽¹⁾	P2IE.2	P2IFG.2	P2IES.2
P2Sel.6	P2DIR.6	P2DIR.6	P2OUT.6	ADC12CLK ⁽³⁾	P2IN.6	unused	P2IE.6	P2IFG.6	P2IES.6
P2Sel.7	P2DIR.7	P2DIR.7	P2OUT.7	Out0 signal ⁽⁴⁾	P2IN.7	unused	P2IE.7	P2IFG.7	P2IES.7

- (1) Signal to Timer_A
- (2) Signal from Comparator_A
- (3) ADC12CLK signal is output of the 12-bit ADC module
- (4) Signal from Timer_A



Figure 6-12. Port P2 (P2.3 and P2.4) Diagram

Table 6-18. Port P2 (P2.3 and P2.4) Pin Functions

PnSel.x	PnDIR.x	DIRECTION CONTROL FROM MODULE	PnOUT.x	MODULE X OUT	PnIN.x	MODULE X IN	PnIE.x	PnIFG.x	PnIES.x
P2Sel.3	P2DIR.3	P2DIR.3	P2OUT.3	Out1 signal ⁽¹⁾	P2IN.3	unused	P2IE.3	P2IFG.3	P2IES.3
P2Sel.4	P2DIR.4	P2DIR.4	P2OUT.4	Out2 signal ⁽¹⁾	P2IN.4	unused	P2IE.4	P2IFG.4	P2IES.4

(1) Signal from Timer_A



Figure 6-13. Port P2 (P2.5) Diagram

Table 6-19. Port P2 (P2.5) Pin Functions

PnSel.x	PnDIR.x	DIRECTION CONTROL FROM MODULE	PnOUT.x	MODULE X OUT	PnIN.x	MODULE X IN	PnIE.x	PnIFG.x	PnIES.x
P2Sel.5	P2DIR.5	P2DIR.5	P2OUT.5	DV _{SS}	P2IN.5	unused	P2IE.5	P2IFG.5	P2IES.5

6.9.3 Port P3, Input/Output With Schmitt Trigger



Figure 6-14. Port P3 (P3.0 and 3.4 to 3.7) Diagram

Table 6-20. Port P3 (P3.0 and 3.4 to 3.7) Pin Functions

PnSel.x	PnDIR.x	DIRECTION CONTROL FROM MODULE	PnOUT.x	MODULE X OUT	PnIN.x	MODULE X IN
P3Sel.0	P3DIR.0	DV _{SS}	P3OUT.0	DV _{SS}	P3IN.0	STE0
P3Sel.4	P3DIR.4	DV _{CC}	P3OUT.4	UTXD0 ⁽¹⁾	P3IN.4	Unused
P3Sel.5	P3DIR.5	DV _{SS}	P3OUT.5	DV _{SS}	P3IN.5	URXD0 ⁽²⁾
P3Sel.6	P3DIR.6	DV _{CC}	P3OUT.6	UTXD1 ⁽³⁾	P3IN.6	unused
P3Sel.7	P3DIR.7	DV _{SS}	P3OUT.7	DV _{SS}	P3IN.7	URXD1 ⁽⁴⁾

- (1) Output from USART0 module
- (2) Input to USART0 module
- (3) Output from USART1 module in MSP430F14x and MSP430F14x1 devices, DV_{SS} in MSP430F13x devices
- (4) Input to USART1 module in MSP430F14x and MSP430F14x1 devices, unused in MSP430F13x devices



Figure 6-15. Port P3 (P3.1) Diagram



Figure 6-16. Port P3 (P3.2) Diagram



NOTE: UART mode: The UART clock can only be an input. If UART mode and UART function are selected, P3.3/UCLK0 is always an input.
SPI slave mode: The clock applied to UCLK0 is used to shift data in and out.
SPI master mode: The clock to shift data in and out is supplied to connected devices on pin P3.3/UCLK0 (in slave mode).

Figure 6-17. Port P3 (P3.3) Diagram

6.9.4 Port P4, Input/Output With Schmitt Trigger



Figure 6-18. Port P4 (P4.0 to P4.6) Diagram

Table 6-21. Port P4 (P4.0 to P4.6) Pin Functions

PnSel.x	PnDIR.x	DIRECTION CONTROL FROM MODULE	PnOUT.x	MODULE X OUT	PnIN.x	MODULE X IN
P4Sel.0	P4DIR.0	P4DIR.0	P4OUT.0	Out0 signal ⁽¹⁾	P4IN.0	CCI0A / CCI0B ⁽²⁾
P4Sel.1	P4DIR.1	P4DIR.1	P4OUT.1	Out1 signal ⁽¹⁾	P4IN.1	CCI1A / CCI1B ⁽²⁾
P4Sel.2	P4DIR.2	P4DIR.2	P4OUT.2	Out2 signal ⁽¹⁾	P4IN.2	CCI2A / CCI2B ⁽²⁾
P4Sel.3	P4DIR.3	P4DIR.3	P4OUT.3	Out3 signal ⁽¹⁾	P4IN.3	CCI3A / CCI3B ⁽²⁾
P4Sel.4	P4DIR.4	P4DIR.4	P4OUT.4	Out4 signal ⁽¹⁾	P4IN.4	CCI4A / CCI4B ⁽²⁾
P4Sel.5	P4DIR.5	P4DIR.5	P4OUT.5	Out5 signal ⁽¹⁾	P4IN.5	CCI5A / CCI5B ⁽²⁾
P4Sel.6	P4DIR.6	P4DIR.6	P4OUT.6	Out6 signal ⁽¹⁾	P4IN.6	CCI6A ⁽²⁾

(1) Signal from Timer_B

(2) Signal to Timer_B



Figure 6-19. Port P4 (P4.7) Diagram

6.9.5 Port P5, Input/Output With Schmitt Trigger



Figure 6-20. Port P5 (P5.0 and P5.4 to P5.7) Diagram

Table 6-22. Port P5 (P5.0 and P5.4 to P5.7) Pin Functions

PnSel.x	PnDIR.x	DIRECTION CONTROL FROM MODULE	PnOUT.x	MODULE X OUT	PnIN.x	MODULE X IN
P5Sel.0	P5DIR.0	DV _{SS}	P5OUT.0	DV _{SS}	P5IN.0	STE.1
P5Sel.4	P5DIR.4	DV _{CC}	P5OUT.4	MCLK	P5IN.4	unused
P5Sel.5	P5DIR.5	DV _{CC}	P5OUT.5	SMCLK	P5IN.5	unused
P5Sel.6	P5DIR.6	DV _{CC}	P5OUT.6	ACLK	P5IN.6	unused
P5Sel.7	P5DIR.7	DV _{SS}	P5OUT.7	DV _{SS}	P5IN.7	TBOUTH ⁽¹⁾

(1) The TBOUTH signal is used by port module P4, pins P4.0 to P4.6. The function of TBOUTH is most useful when used with Timer_B7.

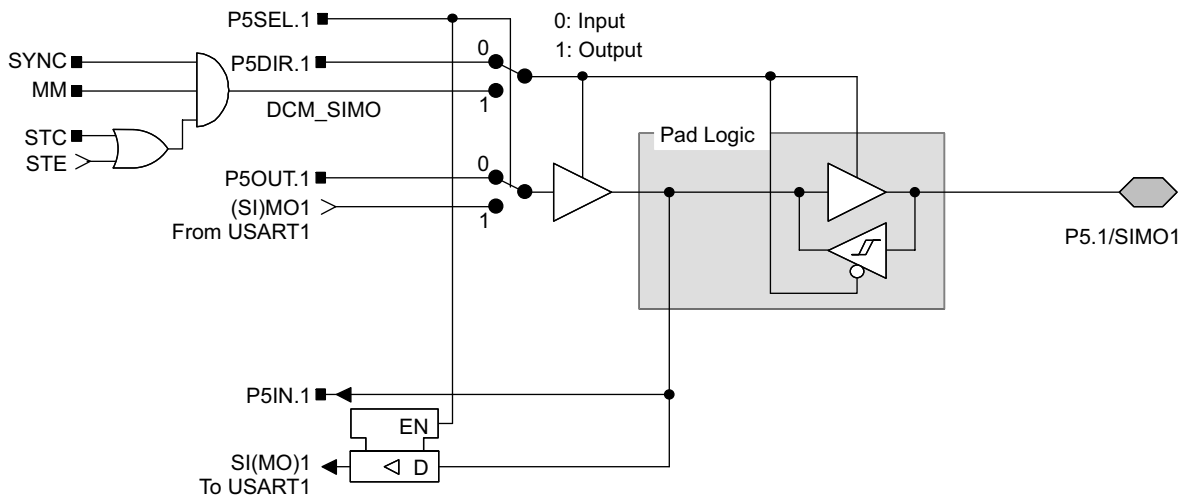
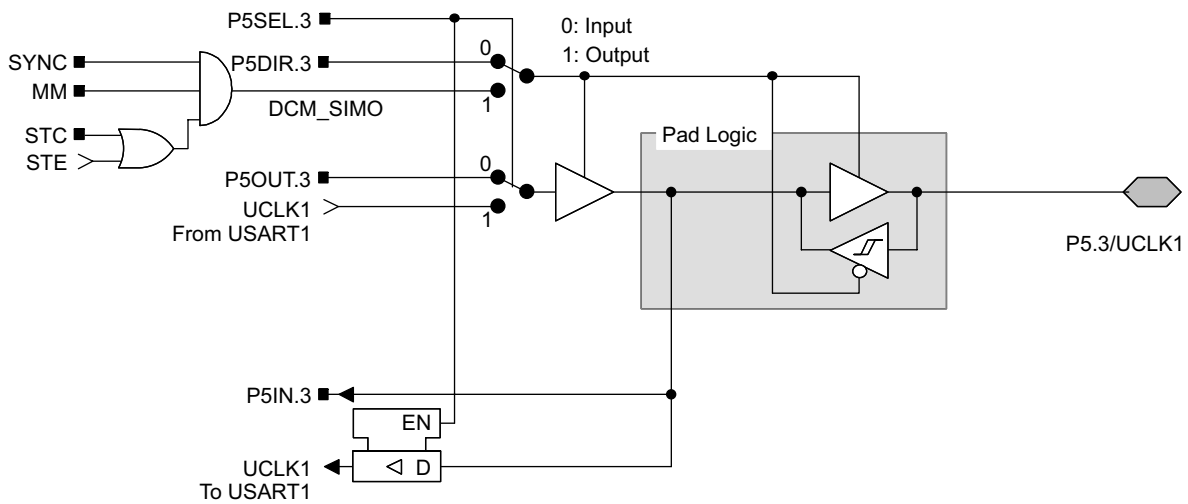

Figure 6-21. Port P5 (P5.1) Diagram



Figure 6-22. Port P5 (P5.2) Diagram



NOTE: UART mode: The UART clock can only be an input. If UART mode and UART function are selected, P5.3/UCLK1 is always an input.
SPI slave mode: The clock applied to UCLK1 is used to shift data in and out.
SPI master mode: The clock to shift data in and out is supplied to connected devices on pin P5.3/UCLK1 (in slave mode).

Figure 6-23. Port P5 (P5.3) Diagram

6.9.6 Port P6, Input/Output With Schmitt Trigger

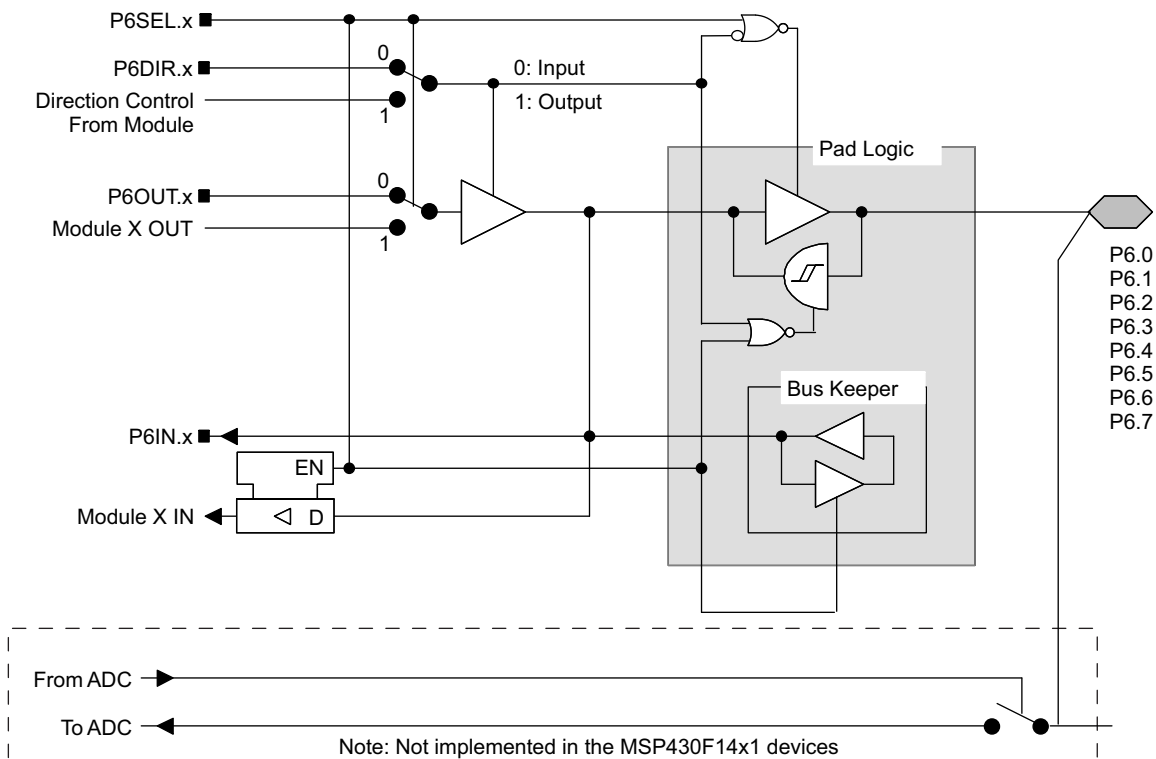

NOTE: Analog signals applied to digital gates can cause current flow from the positive to the negative terminal. The throughput current flows if the analog signal is in the range of transitions 0→1 or 1→0. The value of the throughput current depends on the driving capability of the gate. For MSP430 MCUs, the current is approximately 100 μ A. Use P6SEL.x = 1 to prevent throughput current. P6SEL.x should be set, even if the signal at the pin is not being used by the ADC12.

Figure 6-24. Port P6 (P6.0 to P6.7) Diagram

Table 6-23. Port P6 (P6.0 to P6.7) Pin Functions⁽¹⁾

PnSel.x	PnDIR.x	DIRECTION CONTROL FROM MODULE	PnOUT.x	MODULE X OUT	PnIN.x	MODULE X IN
P6Sel.0	P6DIR.0	P6DIR.0	P6OUT.0	DV _{SS}	P6IN.0	unused
P6Sel.1	P6DIR.1	P6DIR.1	P6OUT.1	DV _{SS}	P6IN.1	unused
P6Sel.2	P6DIR.2	P6DIR.2	P6OUT.2	DV _{SS}	P6IN.2	unused
P6Sel.3	P6DIR.3	P6DIR.3	P6OUT.3	DV _{SS}	P6IN.3	unused
P6Sel.4	P6DIR.4	P6DIR.4	P6OUT.4	DV _{SS}	P6IN.4	unused
P6Sel.5	P6DIR.5	P6DIR.5	P6OUT.5	DV _{SS}	P6IN.5	unused
P6Sel.6	P6DIR.6	P6DIR.6	P6OUT.6	DV _{SS}	P6IN.6	unused
P6Sel.7	P6DIR.7	P6DIR.7	P6OUT.7	DV _{SS}	P6IN.7	unused

(1) The signal at pins P6.x/Ax is used by the 12-bit ADC module.

6.9.7 Port JTAG (TMS, TCK, TDI/TCLK, TDO/TDI), Input/Output With Schmitt Trigger



During programming activity and during blowing of the fuse, the TDO/TDI pin is used to apply the test input data for JTAG circuitry.

Figure 6-25. JTAG (TMS, TCK, TDI/TCLK, TDO/TDI) Diagram

7 Device and Documentation Support

7.1 Getting Started and Next Steps

For more information on the MSP430 family of devices and the tools and libraries that are available to help with your development, visit the [Getting Started](#) page.

7.2 Device Nomenclature

To designate the stages in the product development cycle, TI assigns prefixes to the part numbers of all MSP MCU devices. Each MSP MCU commercial family member has one of two prefixes: MSP or XMS. These prefixes represent evolutionary stages of product development from engineering prototypes (XMS) through fully qualified production devices (MSP).

XMS – Experimental device that is not necessarily representative of the final device's electrical specifications

MSP – Fully qualified production device

XMS devices are shipped against the following disclaimer:

"Developmental product is intended for internal evaluation purposes."

MSP devices have been characterized fully, and the quality and reliability of the device have been demonstrated fully. TI's standard warranty applies.

Predictions show that prototype devices (XMS) have a greater failure rate than the standard production devices. TI recommends that these devices not be used in any production system because their expected end-use failure rate still is undefined. Only qualified production devices are to be used.

TI device nomenclature also includes a suffix with the device family name. This suffix indicates the temperature range, package type, and distribution format. [Figure 7-1](#) provides a legend for reading the complete device name.



NOTE: This figure does not represent a complete list of the available features and options, and it does not indicate that all of these features and options are available for a given device or family.

Figure 7-1. Device Nomenclature – Part Number Decoder

7.3 Tools and Software

Table 7-1 lists the debug features supported by the MSP430F14x, MSP430F14x1, and MSP430F13x microcontrollers. See the [Code Composer Studio for MSP430 User's Guide](#) for details on the available features.

Table 7-1. Hardware Features

MSP430 ARCHITECTURE	4-WIRE JTAG	2-WIRE JTAG	BREAK-POINTS	RANGE BREAK-POINTS	CLOCK CONTROL	STATE SEQUENCER	TRACE BUFFER	LPMx.5 DEBUGGING SUPPORT
MSP430	Yes	No	3	Yes	No	No	No	No

Design Kits and Evaluation Modules

64-pin Target Development Board and MSP-FET Programmer Bundle - MSP430F1x, MSP430F2x, MSP430F4x MCUs The MSP-FET430U64 is a powerful flash emulation tool that includes the hardware and software required to quickly begin application development on the MSP430 MCU. It includes a ZIF socket target board (MSP-TS430PM64) and a USB debugging interface (MSP-FET) used to program and debug the MSP430 in-system through the JTAG interface. The flash memory can be erased and programmed in seconds with only a few keystrokes, and because the MSP430 flash is ultra-low power, no external power supply is required.

MSP-TS430PM64 - 64-pin Target Development Board for MSP430F1x, MSP430F2x and MSP430F4x MCUs

The MSP-TS430PM64 is a standalone ZIF socket target board used to program and debug the MSP430 MCU in-system through the JTAG interface.

Software

MSP430Ware™ Software MSP430Ware software is a collection of code examples, data sheets, and other design resources for all MSP430 devices delivered in a convenient package. In addition to providing a complete collection of existing MSP430 MCU design resources, MSP430Ware software also includes a high-level API called MSP Driver Library. This library makes it easy to program MSP430 hardware. MSP430Ware software is available as a component of CCS or as a stand-alone package.

MSP430F13x, MSP430F14x, MSP430F15x, MSP430F16x Code Examples C Code examples are available for every MSP device that configures each of the integrated peripherals for various application needs.

Bootloader (BSL) for MSP low-power microcontrollers The bootloader (BSL) is an application built into MSP low-power microcontrollers. It lets the user communicate with the device to read from and write to its memory. This feature is primarily used for programming the device, during prototyping, final production, and in service. Both the programmable memory (flash memory) and the data memory (RAM) can be modified as required.

Fixed Point Math Library for MSP The MSP IQmath and Qmath Libraries are a collection of highly optimized and high-precision mathematical functions for C programmers to seamlessly port a floating-point algorithm into fixed-point code on MSP430 and MSP432 devices. These routines are typically used in computationally intensive real-time applications where optimal execution speed, high accuracy, and ultra-low energy are critical. By using the IQmath and Qmath libraries, it is possible to achieve execution speeds considerably faster and energy consumption considerably lower than equivalent code written using floating-point math.

Development Tools

Code Composer Studio™ Integrated Development Environment for MSP Microcontrollers Code Composer Studio (CCS) integrated development environment (IDE) supports all MSP microcontroller devices. CCS comprises a suite of embedded software utilities used to develop and debug embedded applications. CCS includes an optimizing C/C++ compiler, source code editor, project build environment, debugger, profiler, and many other features.

Command-Line Programmer MSP Flasher is an open-source shell-based interface for programming MSP microcontrollers through a FET programmer or eZ430 using JTAG or Spy-Bi-Wire (SBW) communication. MSP Flasher can download binary files (.txt or .hex) directly to the MSP microcontroller without an IDE.

MSP MCU Programmer and Debugger The MSP-FET is a powerful emulation development tool – often called a debug probe – which lets users quickly begin application development on MSP low-power MCUs. Creating MCU software usually requires downloading the resulting binary program to the MSP device for validation and debugging.

MSP-GANG Production Programmer The MSP Gang Programmer is an MSP430 or MSP432 device programmer that can program up to eight identical MSP430 or MSP432 flash or FRAM devices at the same time. The MSP Gang Programmer connects to a host PC using a standard RS-232 or USB connection and provides flexible programming options that let the user fully customize the process.

7.4 Documentation Support

The following documents describe the MSP430F14x, MSP430F14x1, and MSP430F13x MCUs. Copies of these documents are available on the Internet at www.ti.com.

Receiving Notification of Document Updates

To receive notification of documentation updates—including silicon errata—go to the product folder for your device on ti.com (for links to product folders, see [Section 7.5](#)). In the upper right corner, click the "Alert me" button. This registers you to receive a weekly digest of product information that has changed (if any). For change details, check the revision history of any revised document.

Errata

- MSP430F149 Device Erratasheet** Describes the known exceptions to the functional specifications.
- MSP430F1491 Device Erratasheet** Describes the known exceptions to the functional specifications.
- MSP430F148 Device Erratasheet** Describes the known exceptions to the functional specifications.
- MSP430F1481 Device Erratasheet** Describes the known exceptions to the functional specifications.
- MSP430F147 Device Erratasheet** Describes the known exceptions to the functional specifications.
- MSP430F1471 Device Erratasheet** Describes the known exceptions to the functional specifications.
- MSP430F135 Device Erratasheet** Describes the known exceptions to the functional specifications.
- MSP430F133 Device Erratasheet** Describes the known exceptions to the functional specifications.

User's Guides

- MSP430x1xx Family User's Guide** Detailed description of all modules and peripherals available in this device family.
- MSP430 Flash Device Bootloader (BSL) User's Guide** The MSP430™ bootloader (BSL) lets users communicate with embedded memory in the MSP430 microcontroller (MCU) during the prototyping phase, final production, and in service. Both the programmable memory (flash memory) and the data memory (RAM) can be modified as required.
- MSP430 Programming With the JTAG Interface** This document describes the functions that are required to erase, program, and verify the memory module of the MSP430 flash-based and FRAM-based microcontroller families using the JTAG communication port. In addition, it describes how to program the JTAG access security fuse that is available on all MSP430 devices. This document describes device access using both the standard 4-wire JTAG interface and the 2-wire JTAG interface, which is also referred to as Spy-Bi-Wire (SBW).
- MSP430 Hardware Tools User's Guide** This manual describes the hardware of the TI MSP-FET430 Flash Emulation Tool (FET). The FET is the program development tool for the MSP430 ultra-low-power microcontroller. Both available interface types, the parallel port interface and the USB interface, are described.

Application Reports

MSP430 32-kHz Crystal Oscillators Selection of the right crystal, correct load circuit, and proper board layout are important for a stable crystal oscillator. This application report summarizes crystal oscillator function and explains the parameters to select the correct crystal for MSP430 ultra-low-power operation. In addition, hints and examples for correct board layout are given. The document also contains detailed information on the possible oscillator tests to ensure stable oscillator operation in mass production.

Software Coding Techniques for MSP430™ MCUs This application report describes software techniques and related topics of interest to programmers of MSP430 MCUs.

General Oversampling of MSP ADCs for Higher Resolution Multiple MSP430 ultra-low-power microcontrollers offer ADCs to convert physical quantities into digital numbers, a function that is widely used across numerous applications. There are times, however, when a customer design demands a higher resolution than the ADC of the selected MSP can offer. This application report describes how an oversampling method can be incorporated to increase ADC resolution past the currently available number of bits.

MSP430 System-Level ESD Considerations System-Level ESD has become increasingly demanding with silicon technology scaling towards lower voltages and the need for designing cost-effective and ultra-low-power components. This application report addresses three different ESD topics to help board designers and OEMs understand and design robust system-level designs.

7.5 Related Links

Table 7-2 lists quick access links. Categories include technical documents, support and community resources, tools and software, and quick access to order now.

Table 7-2. Related Links

PARTS	PRODUCT FOLDER	ORDER NOW	TECHNICAL DOCUMENTS	TOOLS & SOFTWARE	SUPPORT & COMMUNITY
MSP430F149	Click here	Click here	Click here	Click here	Click here
MSP430F1491	Click here	Click here	Click here	Click here	Click here
MSP430F148	Click here	Click here	Click here	Click here	Click here
MSP430F1481	Click here	Click here	Click here	Click here	Click here
MSP430F147	Click here	Click here	Click here	Click here	Click here
MSP430F1471	Click here	Click here	Click here	Click here	Click here
MSP430F135	Click here	Click here	Click here	Click here	Click here

7.6 Community Resources

The following links connect to TI community resources. Linked contents are provided "AS IS" by the respective contributors. They do not constitute TI specifications and do not necessarily reflect TI's views; see TI's [Terms of Use](#).

TI E2E™ Community

TI's Engineer-to-Engineer (E2E) Community. Created to foster collaboration among engineers. At e2e.ti.com, you can ask questions, share knowledge, explore ideas, and help solve problems with fellow engineers.

TI Embedded Processors Wiki

Texas Instruments Embedded Processors Wiki. Established to help developers get started with embedded processors from Texas Instruments and to foster innovation and growth of general knowledge about the hardware and software surrounding these devices.

7.7 Trademarks

MSP430, MSP430Ware, Code Composer Studio, E2E are trademarks of Texas Instruments. All other trademarks are the property of their respective owners.

7.8 Electrostatic Discharge Caution



This integrated circuit can be damaged by ESD. Texas Instruments recommends that all integrated circuits be handled with appropriate precautions. Failure to observe proper handling and installation procedures can cause damage.

ESD damage can range from subtle performance degradation to complete device failure. Precision integrated circuits may be more susceptible to damage because very small parametric changes could cause the device not to meet its published specifications.

7.9 Export Control Notice

Recipient agrees to not knowingly export or re-export, directly or indirectly, any product or technical data (as defined by the U.S., EU, and other Export Administration Regulations) including software, or any controlled product restricted by other applicable national regulations, received from disclosing party under nondisclosure obligations (if any), or any direct product of such technology, to any destination to which such export or re-export is restricted or prohibited by U.S. or other applicable laws, without obtaining prior authorization from U.S. Department of Commerce and other competent Government authorities to the extent required by those laws.

7.10 Glossary

[TI Glossary](#) This glossary lists and explains terms, acronyms, and definitions.

8 Mechanical, Packaging, and Orderable Information

The following pages include mechanical, packaging, and orderable information. This information is the most current data available for the designated devices. This data is subject to change without notice and revision of this document. For browser-based versions of this data sheet, refer to the left-hand navigation.

PACKAGING INFORMATION

Orderable Device	Status (1)	Package Type	Package Drawing	Pins	Package Qty	Eco Plan (2)	Lead/Ball Finish (6)	MSL Peak Temp (3)	Op Temp (°C)	Device Marking (4/5)	Samples
MSP430F133IPAG	ACTIVE	TQFP	PAG	64	160	Green (RoHS & no Sb/Br)	CU NIPDAU	Level-4-260C-72 HR	-40 to 85	M430F133	Samples
MSP430F133IPM	ACTIVE	LQFP	PM	64	160	Green (RoHS & no Sb/Br)	CU NIPDAU	Level-3-260C-168 HR	-40 to 85	M430F133	Samples
MSP430F133IPMR	ACTIVE	LQFP	PM	64	1000	Green (RoHS & no Sb/Br)	CU NIPDAU	Level-3-260C-168 HR	-40 to 85	M430F133	Samples
MSP430F133IRTD	ACTIVE	VQFN	RTD	64	250	Green (RoHS & no Sb/Br)	CU SN	Level-3-260C-168 HR	-40 to 85	M430F133	Samples
MSP430F135IPAG	ACTIVE	TQFP	PAG	64	160	Green (RoHS & no Sb/Br)	CU NIPDAU	Level-4-260C-72 HR	-40 to 85	M430F135 REV #	Samples
MSP430F135IPM	ACTIVE	LQFP	PM	64	160	Green (RoHS & no Sb/Br)	CU NIPDAU	Level-3-260C-168 HR	-40 to 85	M430F135 REV #	Samples
MSP430F135IPMR	ACTIVE	LQFP	PM	64	1000	Green (RoHS & no Sb/Br)	CU NIPDAU	Level-3-260C-168 HR	-40 to 85	M430F135 REV #	Samples
MSP430F135IRTD	ACTIVE	VQFN	RTD	64	2500	Green (RoHS & no Sb/Br)	CU SN	Level-3-260C-168 HR	-40 to 85	M430F135	Samples
MSP430F135IRTD	ACTIVE	VQFN	RTD	64	250	Green (RoHS & no Sb/Br)	CU SN	Level-3-260C-168 HR	-40 to 85	M430F135	Samples
MSP430F1471IPM	ACTIVE	LQFP	PM	64	160	Green (RoHS & no Sb/Br)	CU NIPDAU	Level-3-260C-168 HR	-40 to 85	M430F1471 REV #	Samples
MSP430F1471IPMR	ACTIVE	LQFP	PM	64	1000	Green (RoHS & no Sb/Br)	CU NIPDAU	Level-3-260C-168 HR	-40 to 85	M430F1471 REV #	Samples
MSP430F1471IRTD	ACTIVE	VQFN	RTD	64	250	Green (RoHS & no Sb/Br)	CU SN	Level-3-260C-168 HR	-40 to 85	M430F1471	Samples
MSP430F147IPAG	ACTIVE	TQFP	PAG	64	160	Green (RoHS & no Sb/Br)	CU NIPDAU	Level-4-260C-72 HR	-40 to 85	M430F147 REV #	Samples
MSP430F147IPM	ACTIVE	LQFP	PM	64	160	Green (RoHS & no Sb/Br)	CU NIPDAU	Level-3-260C-168 HR	-40 to 85	M430F147 REV #	Samples
MSP430F147IPMR	ACTIVE	LQFP	PM	64	1000	Green (RoHS & no Sb/Br)	CU NIPDAU	Level-3-260C-168 HR	-40 to 85	M430F147 REV #	Samples
MSP430F147IPMR-KAM	ACTIVE	LQFP	PM	64	1000	Green (RoHS & no Sb/Br)	CU NIPDAU	Level-3-260C-168 HR	-40 to 85	M430F147 REV #	Samples
MSP430F147IPMRG4	ACTIVE	LQFP	PM	64	1000	Green (RoHS & no Sb/Br)	CU NIPDAU	Level-3-260C-168 HR	-40 to 85	M430F147 REV #	Samples

Orderable Device	Status (1)	Package Type	Package Drawing	Pins	Package Qty	Eco Plan (2)	Lead/Ball Finish (6)	MSL Peak Temp (3)	Op Temp (°C)	Device Marking (4/5)	Samples
MSP430F147IRTDR	ACTIVE	VQFN	RTD	64	2500	Green (RoHS & no Sb/Br)	CU SN	Level-3-260C-168 HR	-40 to 85	M430F147	Samples
MSP430F147IRTD	ACTIVE	VQFN	RTD	64	250	Green (RoHS & no Sb/Br)	CU SN	Level-3-260C-168 HR	-40 to 85	M430F147	Samples
MSP430F1481IPM	ACTIVE	LQFP	PM	64	160	Green (RoHS & no Sb/Br)	CU NIPDAU	Level-3-260C-168 HR	-40 to 85	M430F1481	Samples
MSP430F1481IPMR	ACTIVE	LQFP	PM	64	1000	Green (RoHS & no Sb/Br)	CU NIPDAU	Level-3-260C-168 HR	-40 to 85	M430F1481	Samples
MSP430F1481IRTD	ACTIVE	VQFN	RTD	64	250	Green (RoHS & no Sb/Br)	CU SN	Level-3-260C-168 HR	-40 to 85	M430F1481	Samples
MSP430F148IPAG	ACTIVE	TQFP	PAG	64	160	Green (RoHS & no Sb/Br)	CU NIPDAU	Level-4-260C-72 HR	-40 to 85	M430F148	Samples
MSP430F148IPM	ACTIVE	LQFP	PM	64	160	Green (RoHS & no Sb/Br)	CU NIPDAU	Level-3-260C-168 HR	-40 to 85	M430F148 REV #	Samples
MSP430F148IPMG4	ACTIVE	LQFP	PM	64	160	Green (RoHS & no Sb/Br)	CU NIPDAU	Level-3-260C-168 HR	-40 to 85	M430F148 REV #	Samples
MSP430F148IPMR	ACTIVE	LQFP	PM	64	1000	Green (RoHS & no Sb/Br)	CU NIPDAU	Level-3-260C-168 HR	-40 to 85	M430F148 REV #	Samples
MSP430F148IRTDR	ACTIVE	VQFN	RTD	64	2500	Green (RoHS & no Sb/Br)	CU SN	Level-3-260C-168 HR	-40 to 85	M430F148	Samples
MSP430F148IRTD	ACTIVE	VQFN	RTD	64	250	Green (RoHS & no Sb/Br)	CU SN	Level-3-260C-168 HR	-40 to 85	M430F148	Samples
MSP430F1491IPM	ACTIVE	LQFP	PM	64	160	Green (RoHS & no Sb/Br)	CU NIPDAU	Level-3-260C-168 HR	-40 to 85	M430F1491	Samples
MSP430F1491IPMG4	ACTIVE	LQFP	PM	64	160	Green (RoHS & no Sb/Br)	CU NIPDAU	Level-3-260C-168 HR	-40 to 85	M430F1491	Samples
MSP430F1491IPMR	ACTIVE	LQFP	PM	64	1000	Green (RoHS & no Sb/Br)	CU NIPDAU	Level-3-260C-168 HR	-40 to 85	M430F1491	Samples
MSP430F1491IRTDR	ACTIVE	VQFN	RTD	64	2500	Green (RoHS & no Sb/Br)	CU SN	Level-3-260C-168 HR	-40 to 85	M430F1491	Samples
MSP430F1491IRTD	ACTIVE	VQFN	RTD	64	250	Green (RoHS & no Sb/Br)	CU SN	Level-3-260C-168 HR	-40 to 85	M430F1491	Samples
MSP430F149IPAG	ACTIVE	TQFP	PAG	64	160	Green (RoHS & no Sb/Br)	CU NIPDAU	Level-4-260C-72 HR	-40 to 85	M430F149 REV #	Samples
MSP430F149IPAGR	ACTIVE	TQFP	PAG	64	1500	Green (RoHS & no Sb/Br)	CU NIPDAU	Level-4-260C-72 HR	-40 to 85	M430F149 REV #	Samples

Orderable Device	Status (1)	Package Type	Package Drawing	Pins	Package Qty	Eco Plan (2)	Lead/Ball Finish (6)	MSL Peak Temp (3)	Op Temp (°C)	Device Marking (4/5)	Samples
MSP430F149IPM	ACTIVE	LQFP	PM	64	160	Green (RoHS & no Sb/Br)	CU NIPDAU	Level-3-260C-168 HR	-40 to 85	M430F149 REV #	Samples
MSP430F149IPMG4	ACTIVE	LQFP	PM	64	160	Green (RoHS & no Sb/Br)	CU NIPDAU	Level-3-260C-168 HR	-40 to 85	M430F149 REV #	Samples
MSP430F149IPMR	ACTIVE	LQFP	PM	64	1000	Green (RoHS & no Sb/Br)	CU NIPDAU	Level-3-260C-168 HR	-40 to 85	M430F149 REV #	Samples
MSP430F149IPMRG4	ACTIVE	LQFP	PM	64	1000	Green (RoHS & no Sb/Br)	CU NIPDAU	Level-3-260C-168 HR	-40 to 85	M430F149 REV #	Samples
MSP430F149IRTDR	ACTIVE	VQFN	RTD	64	2500	Green (RoHS & no Sb/Br)	CU SN	Level-3-260C-168 HR	-40 to 85	M430F149	Samples
MSP430F149IRTDRG4	ACTIVE	VQFN	RTD	64	2500	Green (RoHS & no Sb/Br)	CU SN	Level-3-260C-168 HR	-40 to 85	M430F149	Samples
MSP430F149IRTD	ACTIVE	VQFN	RTD	64	250	Green (RoHS & no Sb/Br)	CU SN	Level-3-260C-168 HR	-40 to 85	M430F149	Samples

(1) The marketing status values are defined as follows:

ACTIVE: Product device recommended for new designs.

LIFEBUY: TI has announced that the device will be discontinued, and a lifetime-buy period is in effect.

NRND: Not recommended for new designs. Device is in production to support existing customers, but TI does not recommend using this part in a new design.

PREVIEW: Device has been announced but is not in production. Samples may or may not be available.

OBSOLETE: TI has discontinued the production of the device.

(2) **RoHS:** TI defines "RoHS" to mean semiconductor products that are compliant with the current EU RoHS requirements for all 10 RoHS substances, including the requirement that RoHS substance do not exceed 0.1% by weight in homogeneous materials. Where designed to be soldered at high temperatures, "RoHS" products are suitable for use in specified lead-free processes. TI may reference these types of products as "Pb-Free".

RoHS Exempt: TI defines "RoHS Exempt" to mean products that contain lead but are compliant with EU RoHS pursuant to a specific EU RoHS exemption.

Green: TI defines "Green" to mean the content of Chlorine (Cl) and Bromine (Br) based flame retardants meet JS709B low halogen requirements of <=1000ppm threshold. Antimony trioxide based flame retardants must also meet the <=1000ppm threshold requirement.

(3) MSL, Peak Temp. - The Moisture Sensitivity Level rating according to the JEDEC industry standard classifications, and peak solder temperature.

(4) There may be additional marking, which relates to the logo, the lot trace code information, or the environmental category on the device.

(5) Multiple Device Markings will be inside parentheses. Only one Device Marking contained in parentheses and separated by a "~" will appear on a device. If a line is indented then it is a continuation of the previous line and the two combined represent the entire Device Marking for that device.

⁽⁶⁾ Lead/Ball Finish - Orderable Devices may have multiple material finish options. Finish options are separated by a vertical ruled line. Lead/Ball Finish values may wrap to two lines if the finish value exceeds the maximum column width.

Important Information and Disclaimer:The information provided on this page represents TI's knowledge and belief as of the date that it is provided. TI bases its knowledge and belief on information provided by third parties, and makes no representation or warranty as to the accuracy of such information. Efforts are underway to better integrate information from third parties. TI has taken and continues to take reasonable steps to provide representative and accurate information but may not have conducted destructive testing or chemical analysis on incoming materials and chemicals. TI and TI suppliers consider certain information to be proprietary, and thus CAS numbers and other limited information may not be available for release.

In no event shall TI's liability arising out of such information exceed the total purchase price of the TI part(s) at issue in this document sold by TI to Customer on an annual basis.

TAPE AND REEL INFORMATION

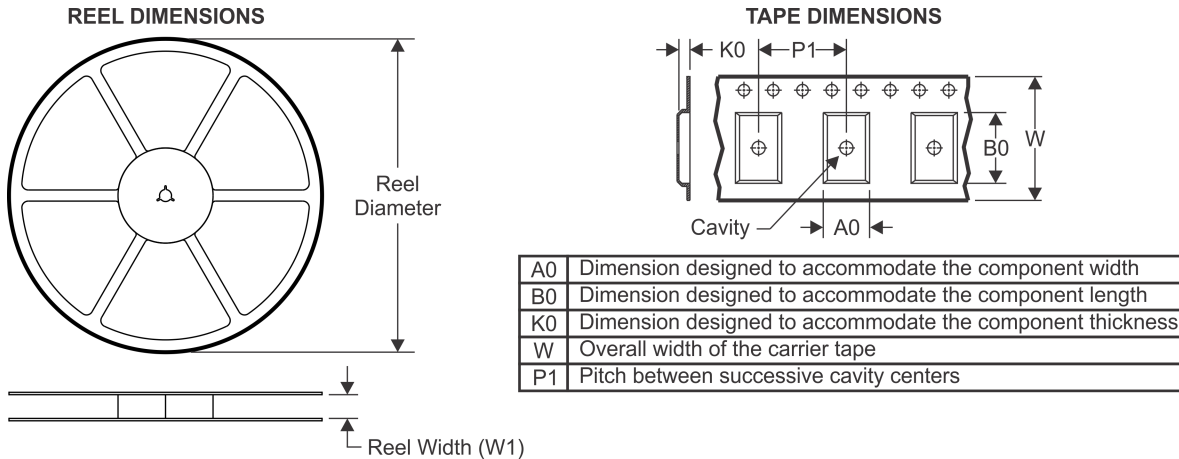

QUADRANT ASSIGNMENTS FOR PIN 1 ORIENTATION IN TAPE



*All dimensions are nominal

Device	Package Type	Package Drawing	Pins	SPQ	Reel Diameter (mm)	Reel Width W1 (mm)	A0 (mm)	B0 (mm)	K0 (mm)	P1 (mm)	W (mm)	Pin1 Quadrant
MSP430F133IPMR	LQFP	PM	64	1000	330.0	24.4	13.0	13.0	2.1	16.0	24.0	Q2
MSP430F133IRTD	VQFN	RTD	64	250	180.0	16.4	9.3	9.3	1.5	12.0	16.0	Q2
MSP430F135IPMR	LQFP	PM	64	1000	330.0	24.4	13.0	13.0	2.1	16.0	24.0	Q2
MSP430F135IRTD	VQFN	RTD	64	2500	330.0	16.4	9.3	9.3	1.5	12.0	16.0	Q2
MSP430F135IRTD	VQFN	RTD	64	250	180.0	16.4	9.3	9.3	1.5	12.0	16.0	Q2
MSP430F1471IPMR	LQFP	PM	64	1000	330.0	24.4	13.0	13.0	2.1	16.0	24.0	Q2
MSP430F1471IRTD	VQFN	RTD	64	250	180.0	16.4	9.3	9.3	1.5	12.0	16.0	Q2
MSP430F147IPMR	LQFP	PM	64	1000	330.0	24.4	13.0	13.0	2.1	16.0	24.0	Q2
MSP430F147IRTD	VQFN	RTD	64	2500	330.0	16.4	9.3	9.3	1.5	12.0	16.0	Q2
MSP430F147IRTD	VQFN	RTD	64	250	180.0	16.4	9.3	9.3	1.5	12.0	16.0	Q2
MSP430F1481IPMR	LQFP	PM	64	1000	330.0	24.4	13.0	13.0	2.1	16.0	24.0	Q2
MSP430F1481IRTD	VQFN	RTD	64	250	180.0	16.4	9.3	9.3	1.5	12.0	16.0	Q2
MSP430F148IPMR	LQFP	PM	64	1000	330.0	24.4	13.0	13.0	2.1	16.0	24.0	Q2
MSP430F148IRTD	VQFN	RTD	64	2500	330.0	16.4	9.3	9.3	1.5	12.0	16.0	Q2
MSP430F148IRTD	VQFN	RTD	64	250	180.0	16.4	9.3	9.3	1.5	12.0	16.0	Q2
MSP430F1491IPMR	LQFP	PM	64	1000	330.0	24.4	13.0	13.0	2.1	16.0	24.0	Q2
MSP430F1491IRTD	VQFN	RTD	64	2500	330.0	16.4	9.3	9.3	1.5	12.0	16.0	Q2
MSP430F1491IRTD	VQFN	RTD	64	250	180.0	16.4	9.3	9.3	1.5	12.0	16.0	Q2

Device	Package Type	Package Drawing	Pins	SPQ	Reel Diameter (mm)	Reel Width W1 (mm)	A0 (mm)	B0 (mm)	K0 (mm)	P1 (mm)	W (mm)	Pin1 Quadrant
MSP430F149IPAGR	TQFP	PAG	64	1500	330.0	24.4	13.0	13.0	1.5	16.0	24.0	Q2
MSP430F149IPMR	LQFP	PM	64	1000	330.0	24.4	13.0	13.0	2.1	16.0	24.0	Q2
MSP430F149IRTD	VQFN	RTD	64	2500	330.0	16.4	9.3	9.3	1.5	12.0	16.0	Q2
MSP430F149IRTD	VQFN	RTD	64	250	180.0	16.4	9.3	9.3	1.5	12.0	16.0	Q2

TAPE AND REEL BOX DIMENSIONS

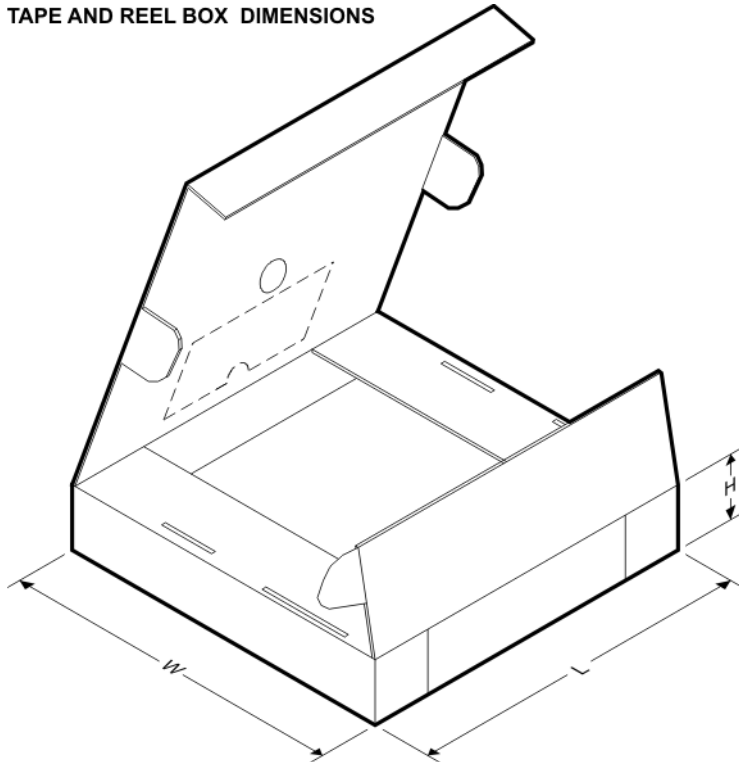

*All dimensions are nominal

Device	Package Type	Package Drawing	Pins	SPQ	Length (mm)	Width (mm)	Height (mm)
MSP430F133IPMR	LQFP	PM	64	1000	336.6	336.6	41.3
MSP430F133IRTD	VQFN	RTD	64	250	210.0	185.0	35.0
MSP430F135IPMR	LQFP	PM	64	1000	336.6	336.6	41.3
MSP430F135IRTD	VQFN	RTD	64	2500	367.0	367.0	38.0
MSP430F135IRTD	VQFN	RTD	64	250	210.0	185.0	35.0
MSP430F1471IPMR	LQFP	PM	64	1000	336.6	336.6	41.3
MSP430F1471IRTD	VQFN	RTD	64	250	210.0	185.0	35.0
MSP430F147IPMR	LQFP	PM	64	1000	336.6	336.6	41.3
MSP430F147IRTD	VQFN	RTD	64	2500	367.0	367.0	38.0
MSP430F147IRTD	VQFN	RTD	64	250	210.0	185.0	35.0
MSP430F1481IPMR	LQFP	PM	64	1000	336.6	336.6	41.3
MSP430F1481IRTD	VQFN	RTD	64	250	210.0	185.0	35.0
MSP430F148IPMR	LQFP	PM	64	1000	336.6	336.6	41.3

Device	Package Type	Package Drawing	Pins	SPQ	Length (mm)	Width (mm)	Height (mm)
MSP430F148IRTDR	VQFN	RTD	64	2500	367.0	367.0	38.0
MSP430F148IRTD	VQFN	RTD	64	250	210.0	185.0	35.0
MSP430F1491IPMR	LQFP	PM	64	1000	336.6	336.6	41.3
MSP430F1491IRTDR	VQFN	RTD	64	2500	367.0	367.0	38.0
MSP430F1491IRTD	VQFN	RTD	64	250	210.0	185.0	35.0
MSP430F149IPAGR	TQFP	PAG	64	1500	350.0	350.0	43.0
MSP430F149IPMR	LQFP	PM	64	1000	336.6	336.6	41.3
MSP430F149IRTDR	VQFN	RTD	64	2500	367.0	367.0	38.0
MSP430F149IRTD	VQFN	RTD	64	250	210.0	185.0	35.0

GENERIC PACKAGE VIEW

RTD 64

VQFN - 0.9 mm max height

PLASTIC QUAD FLATPACK - NO LEAD



Images above are just a representation of the package family, actual package may vary.
Refer to the product data sheet for package details.

4205146/D

MECHANICAL DATA

RTD (S-PVQFN-N64)

PLASTIC QUAD FLATPACK NO-LEAD

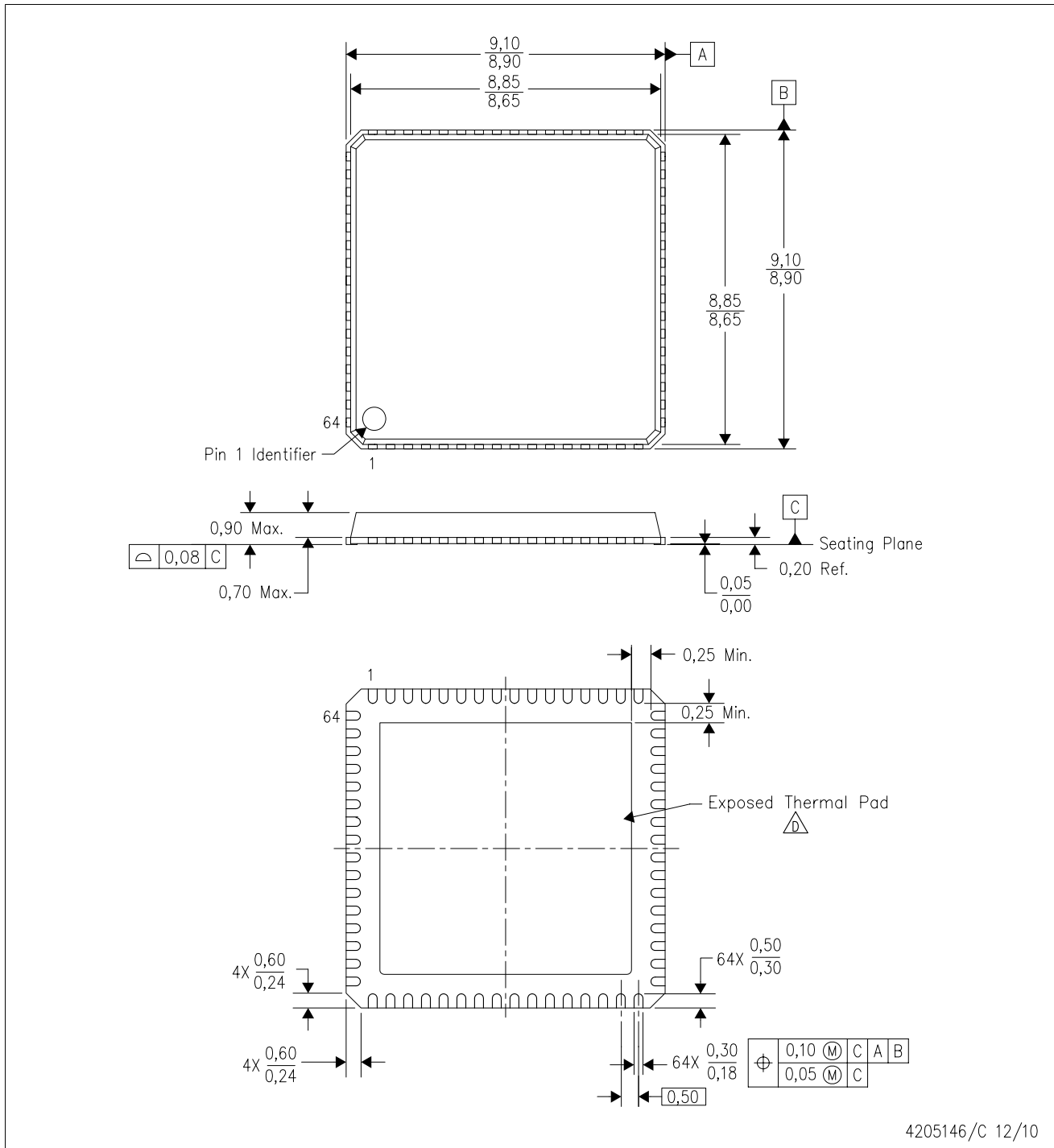

4205146/C 12/10

- NOTES:
- A. All linear dimensions are in millimeters. Dimensioning and tolerancing per ASME Y14.5M-1994.
 - B. This drawing is subject to change without notice.
 - C. QFN (Quad Flatpack No-Lead) Package configuration.
 -  The package thermal pad must be soldered to the board for thermal and mechanical performance. See the Product Data Sheet for details regarding the exposed thermal pad dimensions.

THERMAL PAD MECHANICAL DATA

RTD (S-PVQFN-N64)

PLASTIC QUAD FLATPACK NO-LEAD

THERMAL INFORMATION

This package incorporates an exposed thermal pad that is designed to be attached directly to an external heatsink. The thermal pad must be soldered directly to the printed circuit board (PCB). After soldering, the PCB can be used as a heatsink. In addition, through the use of thermal vias, the thermal pad can be attached directly to the appropriate copper plane shown in the electrical schematic for the device, or alternatively, can be attached to a special heatsink structure designed into the PCB. This design optimizes the heat transfer from the integrated circuit (IC).

For information on the Quad Flatpack No-Lead (QFN) package and its advantages, refer to Application Report, QFN/SON PCB Attachment, Texas Instruments Literature No. SLUA271. This document is available at www.ti.com.

The exposed thermal pad dimensions for this package are shown in the following illustration.



4206338-3/F 09/14

NOTE: A. All linear dimensions are in millimeters

RTD (S-PVQFN-N64)

PLASTIC QUAD FLATPACK NO-LEAD

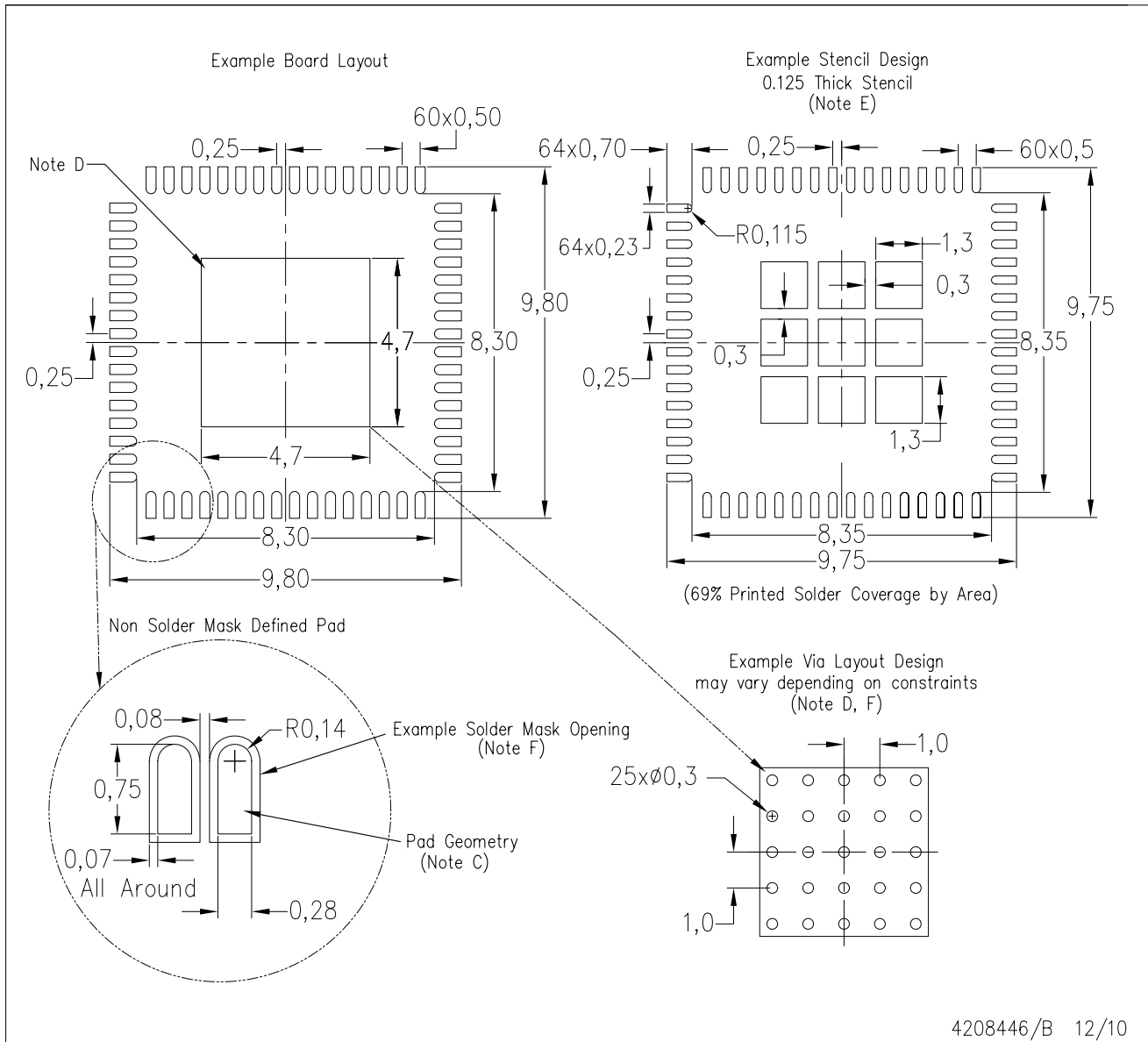

PAG (S-PQFP-G64)

PLASTIC QUAD FLATPACK



- NOTES: A. All linear dimensions are in millimeters.
 B. This drawing is subject to change without notice.
 C. Falls within JEDEC MS-026

PM (S-PQFP-G64)

PLASTIC QUAD FLATPACK

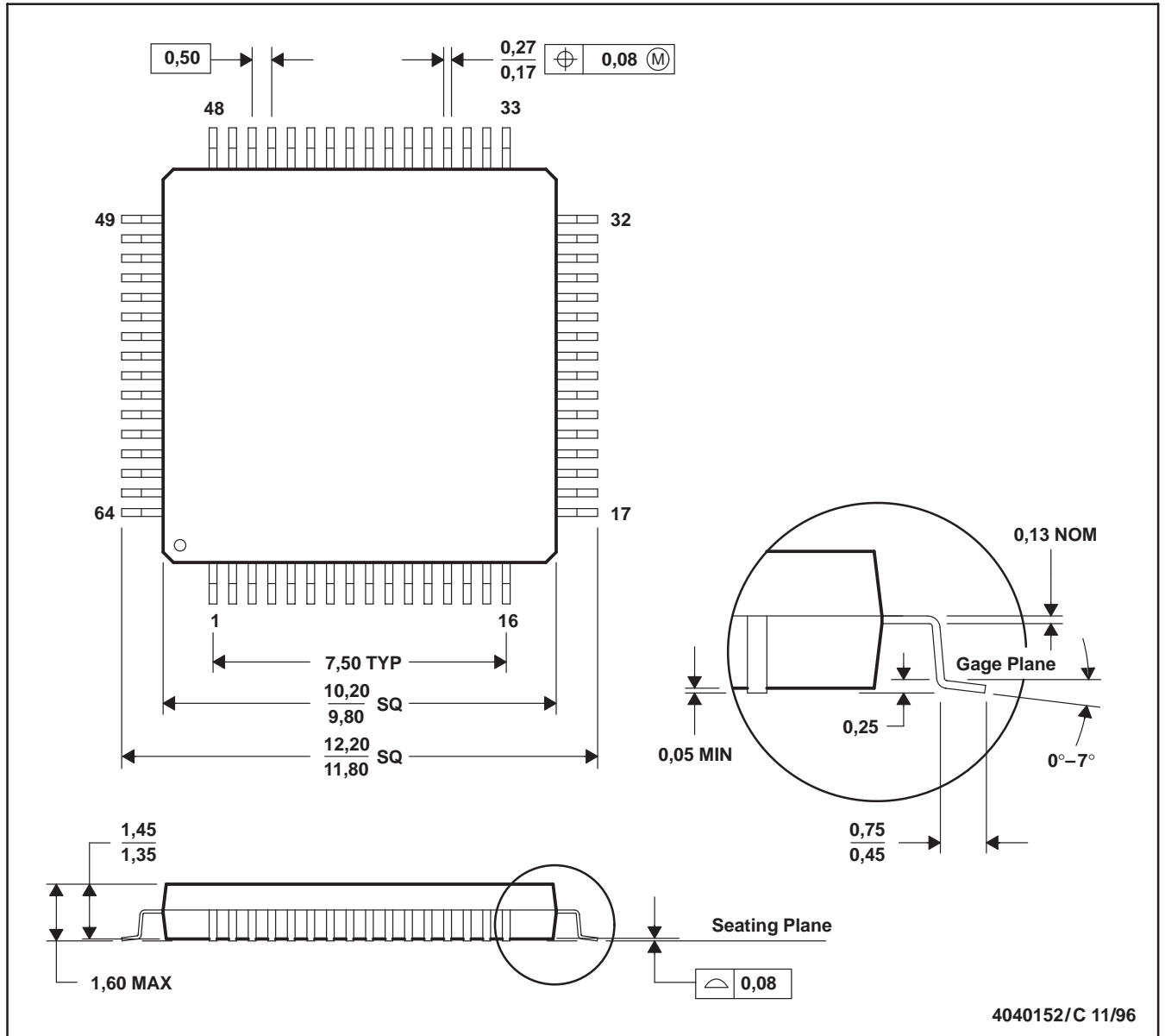

- NOTES: A. All linear dimensions are in millimeters.
 B. This drawing is subject to change without notice.
 C. Falls within JEDEC MS-026
 D. May also be thermally enhanced plastic with leads connected to the die pads.

PM (S-PQFP-G64)

PLASTIC QUAD FLATPACK

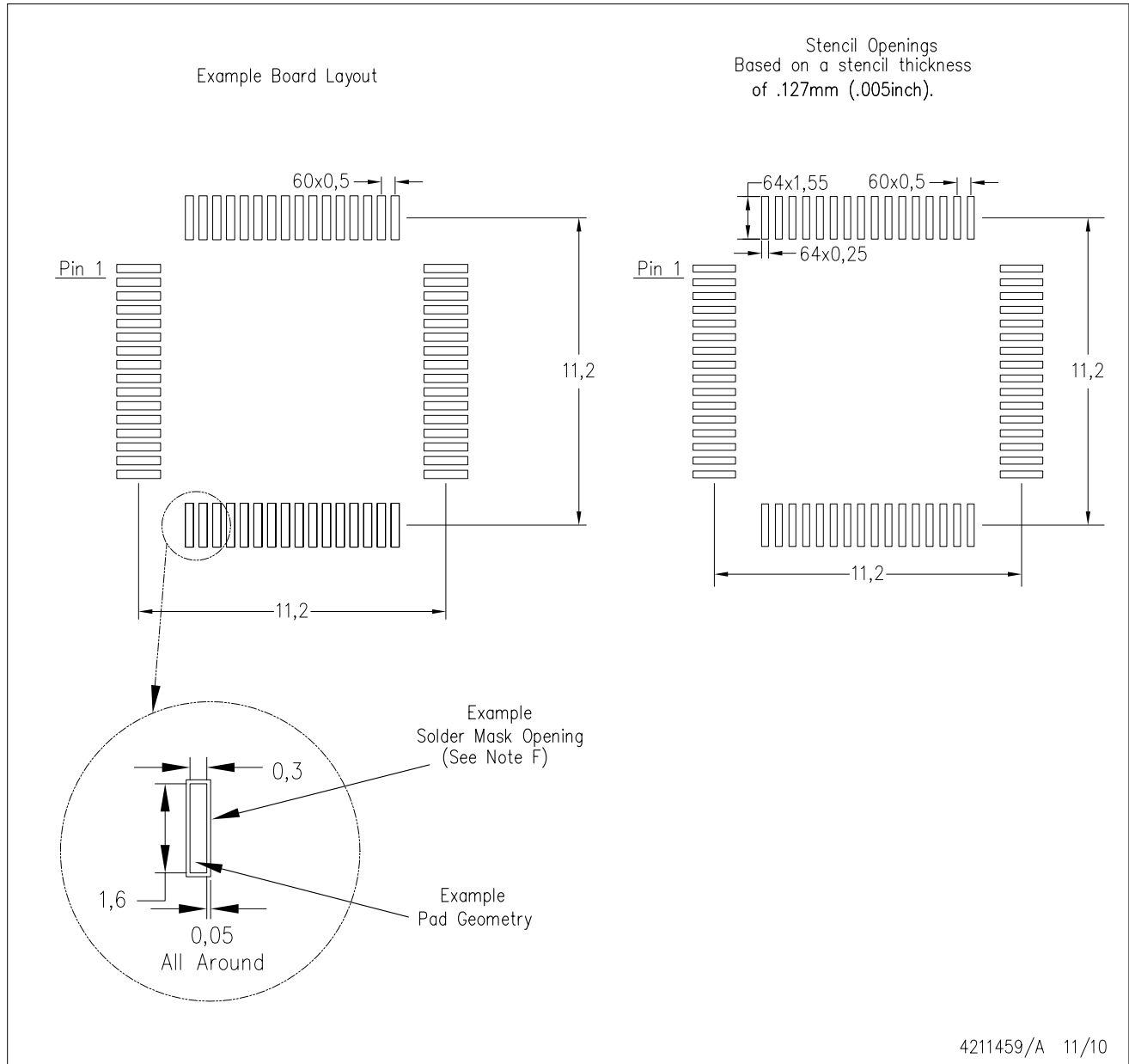

- NOTES:
- A. All linear dimensions are in millimeters.
 - B. This drawing is subject to change without notice.
 - C. Laser cutting apertures with trapezoidal walls and also rounding corners will offer better paste release. Customers should contact their board assembly site for stencil design recommendations. Example stencil design based on a 50% volumetric metal load solder paste. Refer to IPC-7525 for other stencil recommendations.
 - D. Customers should contact their board fabrication site for solder mask tolerances between and around signal pads.

IMPORTANT NOTICE AND DISCLAIMER

TI PROVIDES TECHNICAL AND RELIABILITY DATA (INCLUDING DATASHEETS), DESIGN RESOURCES (INCLUDING REFERENCE DESIGNS), APPLICATION OR OTHER DESIGN ADVICE, WEB TOOLS, SAFETY INFORMATION, AND OTHER RESOURCES "AS IS" AND WITH ALL FAULTS, AND DISCLAIMS ALL WARRANTIES, EXPRESS AND IMPLIED, INCLUDING WITHOUT LIMITATION ANY IMPLIED WARRANTIES OF MERCHANTABILITY, FITNESS FOR A PARTICULAR PURPOSE OR NON-INFRINGEMENT OF THIRD PARTY INTELLECTUAL PROPERTY RIGHTS.

These resources are intended for skilled developers designing with TI products. You are solely responsible for (1) selecting the appropriate TI products for your application, (2) designing, validating and testing your application, and (3) ensuring your application meets applicable standards, and any other safety, security, or other requirements. These resources are subject to change without notice. TI grants you permission to use these resources only for development of an application that uses the TI products described in the resource. Other reproduction and display of these resources is prohibited. No license is granted to any other TI intellectual property right or to any third party intellectual property right. TI disclaims responsibility for, and you will fully indemnify TI and its representatives against, any claims, damages, costs, losses, and liabilities arising out of your use of these resources.

TI's products are provided subject to TI's Terms of Sale (www.ti.com/legal/termsofsale.html) or other applicable terms available either on ti.com or provided in conjunction with such TI products. TI's provision of these resources does not expand or otherwise alter TI's applicable warranties or warranty disclaimers for TI products.

Mailing Address: Texas Instruments, Post Office Box 655303, Dallas, Texas 75265
Copyright © 2019, Texas Instruments Incorporated

Looking for pricing, stock, or lifecycle information?

Click below to explore more details on WIN SOURCE:

 [View MSP430F135IPAG](#) on WIN SOURCE

 [Texas Instruments](#) Information

Optimize Your Supply Chain with WIN SOURCE Solutions

-  Global Sourcing Solution
-  Obsolete Management
-  Cost Control Management
-  Shortage Management
-  Alternative Solution
-  Excess Inventory Management