



**THE DATASHEET OF  
AT17C512A-10JC**



---

## Features

- Serial EEPROM Family for Configuring Altera FLEX® Devices
- Simple Interface to SRAM FPGAs
- EE Programmable 512-Kbit and 1-Mbit Serial Memories Designed to Store Configuration Programs for Field Programmable Gate Arrays (FPGAs)
- Cascadable Read Back to Support Additional Configurations or Future Higher-density Arrays
- Low-power CMOS EEPROM Process
- Programmable Reset Polarity
- Available in the Space-efficient Surface-mount PLCC and PDIP Packages for the 512-Kbit device and PLCC, PDIP and TQFP Packages for the 1-Mbit Device
- In-System Programmable via 2-wire Bus
- Emulation of Atmel's AT24CXXX Serial EEPROMs
- Available in 3.3V ± 10% LV and 5V ± 5% C Versions
- System-friendly READY Pin

## Description

The AT17C512A/010A and AT17LV512A/010A (high-density AT17A Series) FPGA Configuration EEPROMs (Configurators) provide an easy-to-use, cost-effective configuration memory for programming Altera FLEX® devices. The AT17C512A/LV512A devices are packaged in the popular 8-lead PDIP and the 20-lead PLCC; the AT17C010A/LV010A are packaged in the popular 8-lead PDIP, the 20-lead PLCC and the 32-lead TQFP. The AT17A Series family uses a simple serial-access procedure to configure one or more FPGA devices. The AT17A Series organization supplies enough memory to configure one or multiple smaller FPGAs. Using a feature of the AT17A Series, the user can select the polarity of the reset function by programming four EEPROM bytes. The AT17A parts generate their own internal clock by default and can be used as a system “master” for loading the FPGA devices. The internal clock can be disabled by the industrial programmer to allow the AT17A parts to be used as system “slave”, so that the external devices will provide the clock for loading the FPGA devices.

The Atmel devices also support a system-friendly READY pin for the 20-lead PLCC package and a write protect mechanism for all packages. The READY pin is used to simplify system power-up considerations. The WP1 pin is used to protect part of the Configurator memory during in-system programming.

The AT17A Series Configurator can be programmed with industry-standard programmers, Atmel's ATDH2200E Programming Kit or Atmel's ATDH2225 ISP cable.



---

## FPGA Configuration EEPROM Memory

512-kilobit and

1-megabit

Altera Pinout

---

**AT17C512A**

**AT17LV512A**

**AT17C010A**

**AT17LV010A**



## Pin Configuration

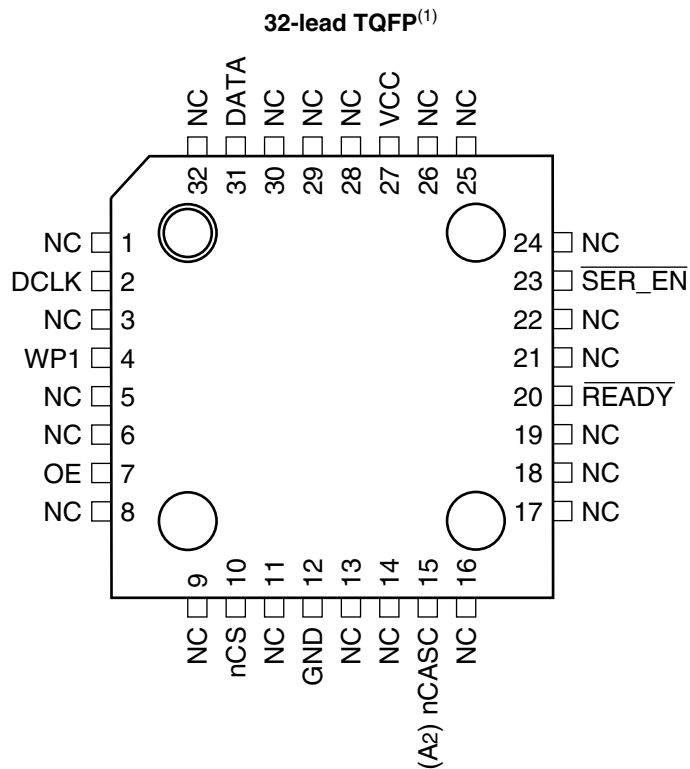
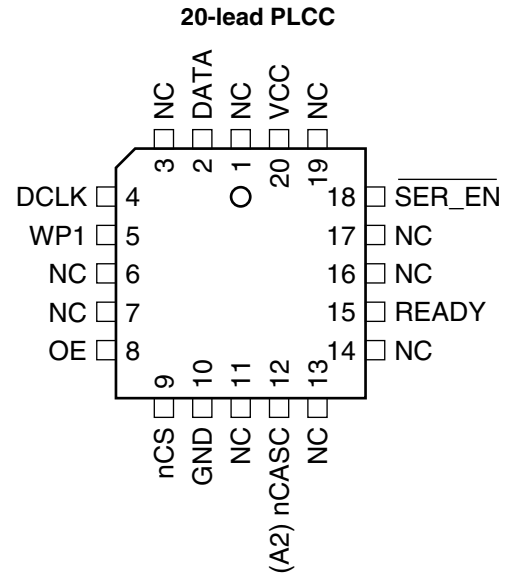
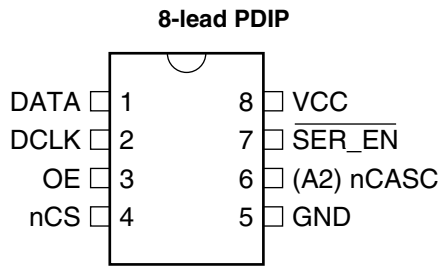

Note: 1. The 32-lead TQFP package is not available for AT17C512A/LV512A devices.

**Block Diagram**

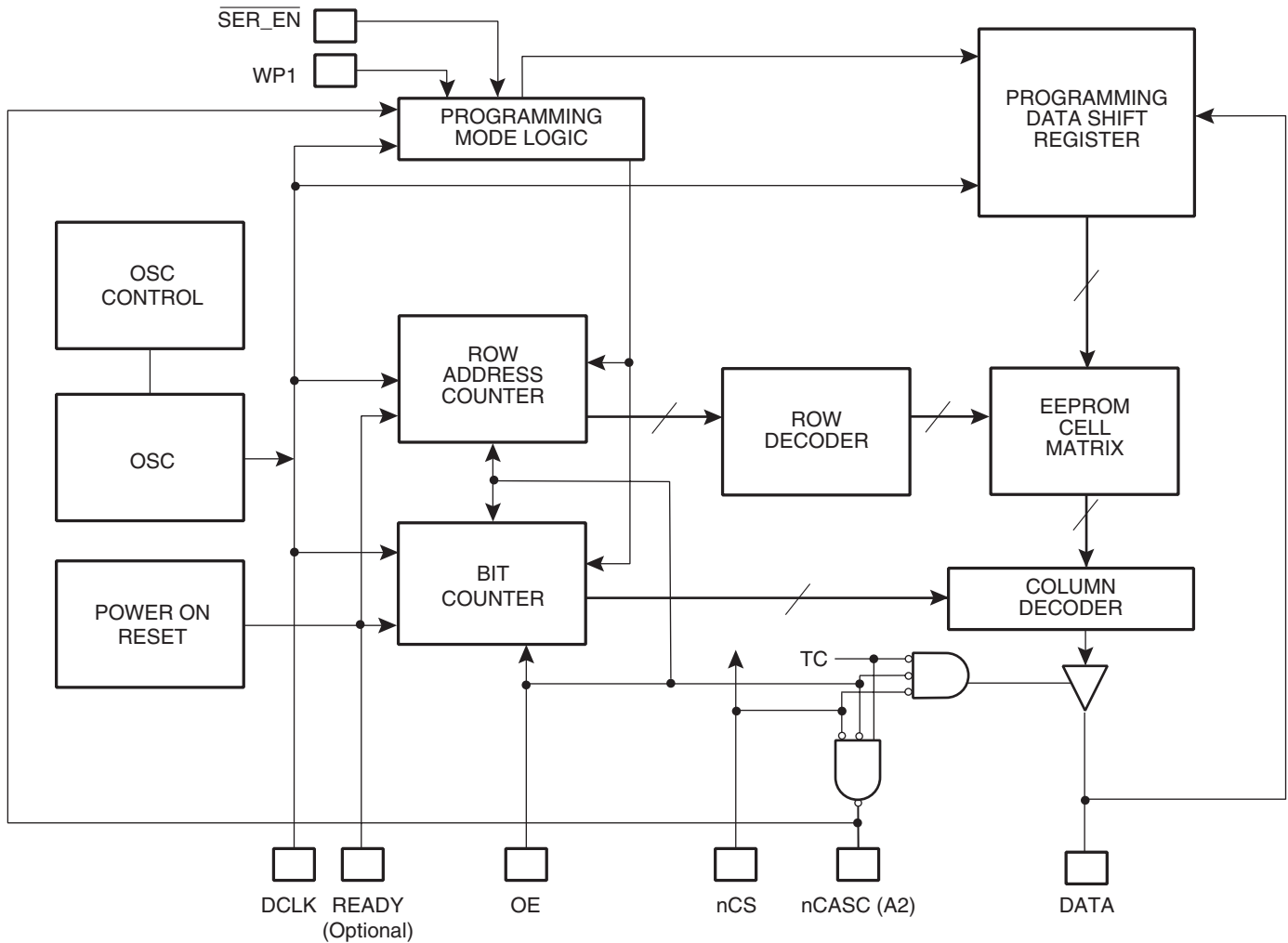

**Device Configuration**

The control signals for the configuration EEPROM (nCS, OE and DCLK) interface directly with the FPGA device control signals. All FPGA devices can control the entire configuration process and retrieve data from the configuration EEPROM without requiring an external intelligent controller.

The configuration EEPROM's OE and nCS pins control the tri-state buffer on the DATA output pin and enable the address counter and the oscillator. When OE is driven Low, the configuration EEPROM resets its address counter and tri-states its DATA pin. The nCS pin also controls the output of the AT17A Series Configurator. If nCS is held High after the OE reset pulse, the counter is disabled and the DATA output pin is tri-stated. When nCS is driven Low, the counter and the DATA output pin are enabled. When OE is driven Low again, the address counter is reset and the DATA output pin is tri-stated, regardless of the state of the nCS.

When the Configurator has driven out all of its data and nCASC is driven Low, the device tri-states the DATA pin to avoid contention with other Configurators. Upon power-up, the address counter is automatically reset.



The READY pin is available as an open-collector indicator of the device's reset status; it is driven Low while the device is in its power-on reset cycle and released (tri-stated) when the cycle is complete.

This document discusses the EPF10K device interface. For more details or information on other Altera applications, please reference the "AT17A Series Conversions from Altera FPGA Serial Configuration Memories" application note.

## FPGA Device Configuration

FPGA devices can be configured with an AT17A Series EEPROM (see Figure 1). The AT17A Series device stores configuration data in its EEPROM array and clocks the data out serially with its internal oscillator. The OE, nCS and DCLK pins supply the control signals for the address counter and the output tri-state buffer. The AT17A Series device sends a serial bitstream of configuration data to its DATA pin, which is connected to the DATA0 input pin on the FPGA device.

When configuration data for an FPGA device exceeds the capacity of a single AT17A Series device, multiple AT17A Series devices can be serially linked together (see Figure 2). When multiple AT17A Series devices are required, the nCASC and nCS pins provide handshaking between the cascaded EEPROMs.

The position of an AT17A Series device in a chain determines its operation. The first AT17A Series device in a Configurator chain is powered up or reset with nCS Low and is configured for the FPGA device's protocol. This AT17A Series device supplies all clock pulses to one or more FPGA devices and to any downstream AT17A Series Configurator during configuration. The first AT17A Series Configurator also provides the first stream of data to the FPGA devices during multi-device configuration. Once the first AT17A Series device finishes sending configuration data, it drives its nCASC pin Low, which drives the nCS pin of the second AT17A Series device Low. This activates the second AT17A Series device to send configuration data to the FPGA device.

The first AT17A Series device clocks all subsequent AT17A Series devices until configuration is complete. Once all configuration data is transferred and nCS on the first AT17A Series device is driven High by CONF\_DONE on the FPGA devices, the first AT17A Series device clocks 16 additional cycles to initialize the FPGA device before going into zero-power (idle) state. If nCS on the first AT17A Series device is driven High before all configuration data is transferred—or if the nCS is not driven High after all configuration data is transferred—nSTATUS is driven Low, indicating a configuration error.

The READY pin is available as an open-collector indicator of the device's reset status; it is driven Low while the device is in its power-on reset cycle and released (tri-stated) when the cycle is complete. It can be used to hold the FPGA device in reset while it is completing its power-on reset but it cannot be used to effectively delay configuration (i.e., the output is released well before the system  $V_{CC}$  has stabilized).

**Figure 1.** Configuration with a Single AT17A Series Configurator<sup>(1)(2)(3)</sup>

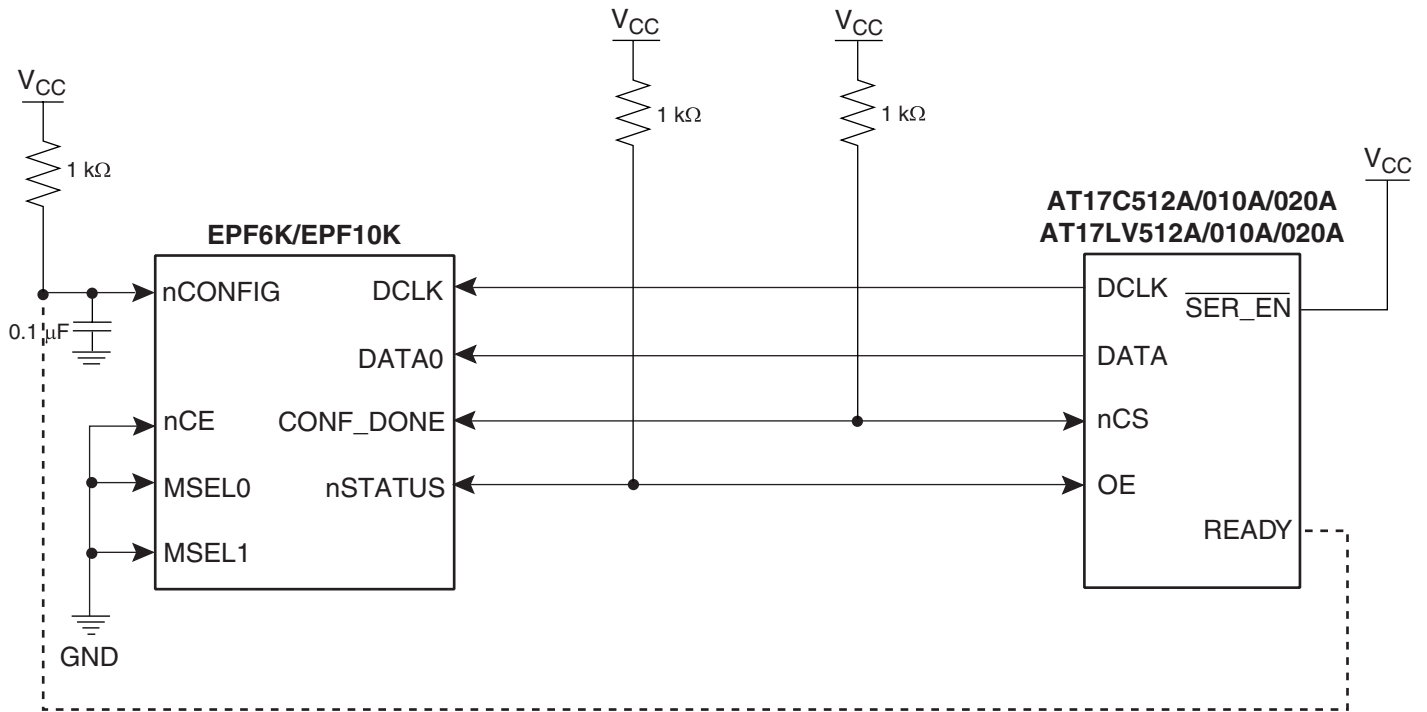

- Notes:
1. The use of the READY pin is optional for the 20-lead PLCC and the 32-lead TQFP packages. The 8-lead PDIP package does not have a READY pin.
  2. Introducing an RC delay to the input of nCONFIG is recommended to ensure that  $V_{CC}$  (5V/3.3V) is reached before configuration begins. (nCONFIG can instead be connected to an active Low system reset signal.)
  3. Reset polarity of EEPROM must be set active Low (OE active High)

**Figure 2.** Configuration with Multiple AT17A Series Configurators<sup>(1)(2)(3)</sup>

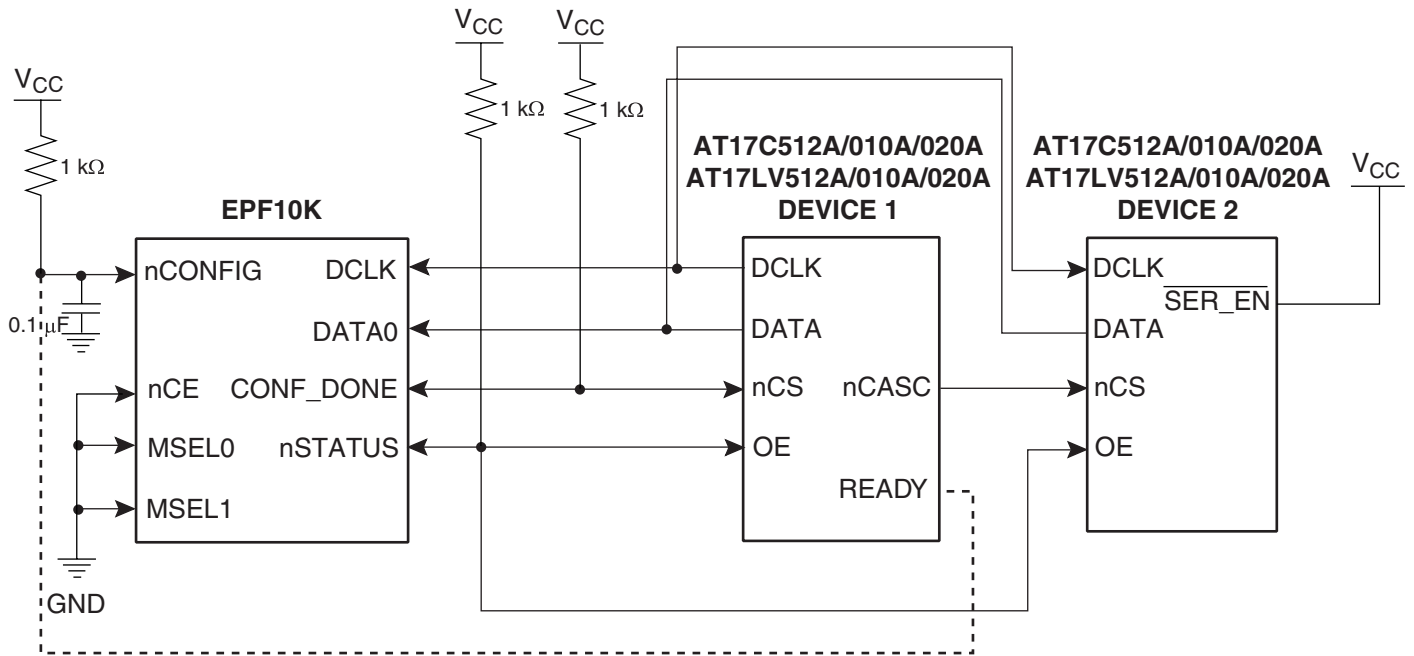

- Notes:
1. The use of the READY pin is optional for the 20-lead PLCC and the 32-lead TQFP packages. The 8-lead PDIP package does not have a READY pin.
  2. Introducing an RC delay to the input of nCONFIG is recommended to ensure that V<sub>CC</sub> (5V/3.3V) is reached before configuration begins. (nCONFIG can instead be connected to an active Low system reset signal.)
  3. Reset polarity of EEPROM must be set active Low (OE active High).

## AT17A Series Reset Polarity

The AT17A Series Configurator allows the user to program the reset polarity as either RESET/OE or  $\overline{\text{RESET}}/\text{OE}$ . For more details, please reference the “Programming Specification for Atmel’s FPGA Configuration EEPROMs” application note.

## Programming Mode

The programming mode is entered by bringing  $\overline{\text{SER\_EN}}$  Low. In this mode the chip can be programmed by the 2-wire serial interface. The programming is done at V<sub>CC</sub> supply only. Programming super voltages are generated inside the chip. See the “Programming Specification for Atmel’s Configuration EEPROMs” application note for further information. The AT17A Series parts are read/write at 5V nominal. The AT17LVA Series parts are read/write at 3.3V nominal.

## Standby Mode

The AT17A Series Configurator enters a low-power standby mode whenever nCS is asserted High. In this mode, the configuration consumes less than 0.5 mA of current at 5V. The output remains in a high-impedance state regardless of the state of the OE input.

## Pin Configurations

8 PDIP Pin	20 PLCC Pin	32 TQFP Pin	Name	I/O	Description
1	2	31	DATA	I/O	Three-state data output for configuration. Open-collector bi-directional pin for programming.
2	4	2	DCLK	I/O	Clock output or clock input. Rising edges on DCLK increment the internal address counter and present the next bit of data to the DATA pin. The counter is incremented only if the OE input is held High, the nCS input is held Low, and all configuration data has not been transferred to the target device (otherwise, as the master device, the DCLK pin drives Low).
	5	4	WP1	I	WRITE PROTECT (1). Used to protect portions of memory during programming. Disabled by default due to internal pull-down resistor. This input pin is not used during FPGA loading operations. See programming specifications for details.
3	8	7	OE	I	Output enable (active High) and reset (active Low) when $\overline{\text{SER\_EN}}$ is High. A Low logic level resets the address counter. A High logic level (with nCS Low) enables DATA and permits the address counter to count. In the mode, if this pin is Low (reset), the internal oscillator becomes inactive and DCLK drives Low. The logic polarity of this input is programmable and must be programmed active High (RESET active Low) by the user during programming for Altera applications.
4	9	10	nCS	I	Chip select input (active Low). A Low input (with OE High) allows DCLK to increment the address counter and enables DATA to drive out. If the AT17A Series is reset with nCS Low, the device initializes as the first (and master) device in a daisy-chain. If the AT17A Series is reset with nCS High, the device initializes as a subsequent AT17A Series device in the chain.
5	10	12	GND		Ground pin. A 0.2 $\mu\text{F}$ decoupling capacitor should be placed between the VCC and GND pins.
6	12	15	nCASC	O	Cascade select output (active Low). This output goes Low when the address counter has reached its maximum value. In a daisy-chain of AT17A Series devices, the nCASC pin of one device is usually connected to the nCS input pin of the next device in the chain, which permits DCLK from the master Configurator to clock data from a subsequent AT17A Series device in the chain.
			A2	I	Device selection input, A2. This is used to enable (or select) the device during programming, (i.e., when $\overline{\text{SER\_EN}}$ is Low; please refer to the "Programming Specification" application note for more details).
	15	20	READY <sup>(1)</sup>	O	Open collector reset state indicator. Driven Low during power-up reset, released (tri-stated) when power-up is complete. (Recommend a 4.7 k $\Omega$ pull-up on this pin if used).
7	18	23	$\overline{\text{SER\_EN}}$	I	Serial enable must be held High during FPGA loading operations. Bringing $\overline{\text{SER\_EN}}$ Low, enables the 2-wire serial programming mode.
8	20	27	VCC		+3.3V/+5V power supply pin

Note: 1. READY is an optional pin. It is not available in the 8-lead PDIP package.



## Absolute Maximum Ratings\*

Operating Temperature .....	-55°C to +125°C
Storage Temperature .....	-65°C to +150°C
Voltage on Any Pin with Respect to Ground .....	-0.1V to $V_{CC} + 0.5V$
Supply Voltage ( $V_{CC}$ ) .....	-0.5V to +7.0V
Maximum Soldering Temp. (10 sec @ 1/16 in.) .....	260°C

\*NOTICE: Stresses beyond those listed under Absolute Maximum Ratings may cause permanent damage to the device. These are stress ratings only, and functional operation of the device at these or any other conditions beyond those listed under Operating Conditions is not implied. Exposure to Absolute Maximum Ratings conditions for extended periods of time may affect device reliability.

## Operating Conditions

Symbol	Description		AT17CXXXA		AT17LVXXXA		Units
			Min	Max	Min	Max	
$V_{CC}$	Commercial	Supply voltage relative to GND -0°C to +70°C	4.75	5.25	3.0	3.6	V
	Industrial	Supply voltage relative to GND -40°C to +85°C	4.5	5.5	3.0	3.6	V
	Military	Supply voltage relative to GND -55°C to +125°C	4.5	5.5	3.0	3.6	V

## DC Characteristics

$V_{CC} = 5V \pm 5\%$  Commercial/ $5V \pm 10\%$  Industrial/Military

Symbol	Description		Min	Max	Units
$V_{IH}$	High-level Input Voltage		2.0	$V_{CC}$	V
$V_{IL}$	Low-level Input Voltage		0.0	0.8	V
$V_{OH}$	High-level Output Voltage ( $I_{OH} = -4$ mA)	Commercial	3.86		V
$V_{OL}$	Low-level Output Voltage ( $I_{OL} = +4$ mA)			0.32	V
$V_{OH}$	High-level Output Voltage ( $I_{OH} = -4$ mA)	Industrial	3.76		V
$V_{OL}$	Low-level Output Voltage ( $I_{OL} = +4$ mA)			0.37	V
$V_{OH}$	High-level Output Voltage ( $I_{OH} = -4$ mA)	Military	3.7		V
$V_{OL}$	Low-level Output Voltage ( $I_{OL} = +4$ mA)			0.4	V
$I_{CCA}$	Supply Current, Active Mode (at FMAX)			10	mA
$I_L$	Input or Output Leakage Current ( $V_{IN} = V_{CC}$ or GND)		-10	10	$\mu$ A
$I_{CCS}$	Supply Current, Standby Mode AT17C512A/010A	Commercial		0.5	mA
		Industrial/Military		0.5	mA

## DC Characteristics

$V_{CC} = 3.3V \pm 10\%$

Symbol	Description		Min	Max	Units
$V_{IH}$	High-level Input Voltage		2.0	$V_{CC}$	V
$V_{IL}$	Low-level Input Voltage		0.0	0.8	V
$V_{OH}$	High-level Output Voltage ( $I_{OH} = -2.5$ mA)	Commercial	2.4		V
$V_{OL}$	Low-level Output Voltage ( $I_{OL} = +3$ mA)			0.4	V
$V_{OH}$	High-level Output Voltage ( $I_{OH} = -2$ mA)	Industrial	2.4		V
$V_{OL}$	Low-level Output Voltage ( $I_{OL} = +3$ mA)			0.4	V
$V_{OH}$	High-level Output Voltage ( $I_{OH} = -2$ mA)	Military	2.4		V
$V_{OL}$	Low-level Output Voltage ( $I_{OL} = +2.5$ mA)			0.4	V
$I_{CCA}$	Supply Current, Active Mode (at FMAX)			5	mA
$I_L$	Input or Output Leakage Current ( $V_{IN} = V_{CC}$ or GND)		-10	10	$\mu$ A
$I_{CCS}$	Supply Current, Standby Mode	Commercial		100	$\mu$ A
		Industrial/Military		100	$\mu$ A

## AC Characteristics

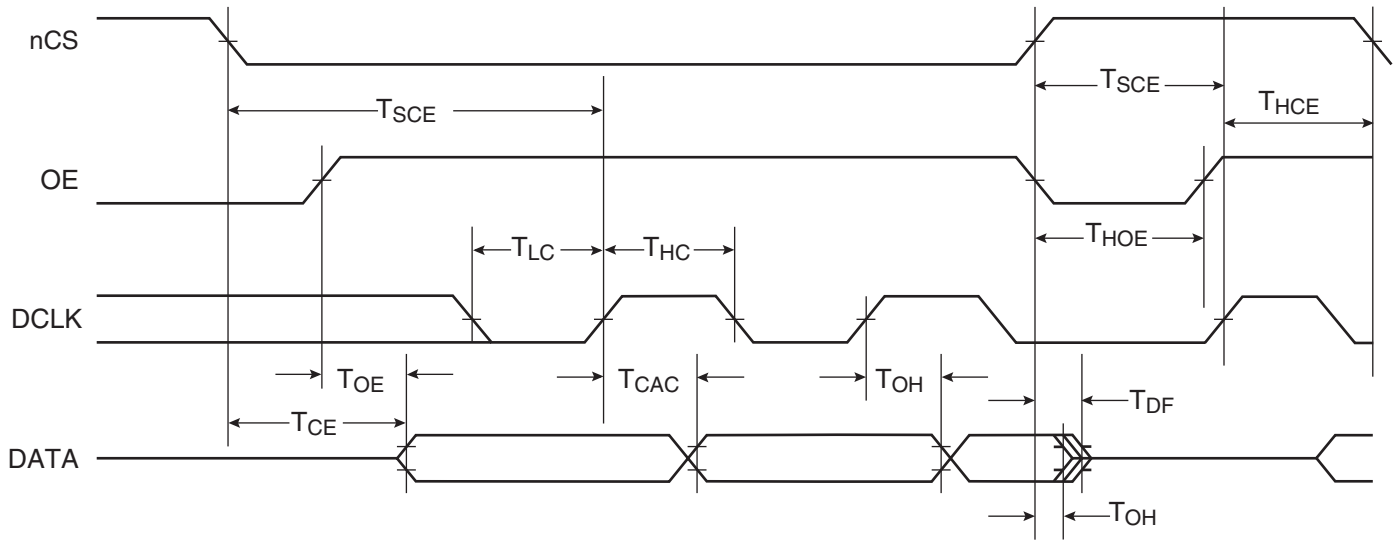

## AC Characteristics When Cascading

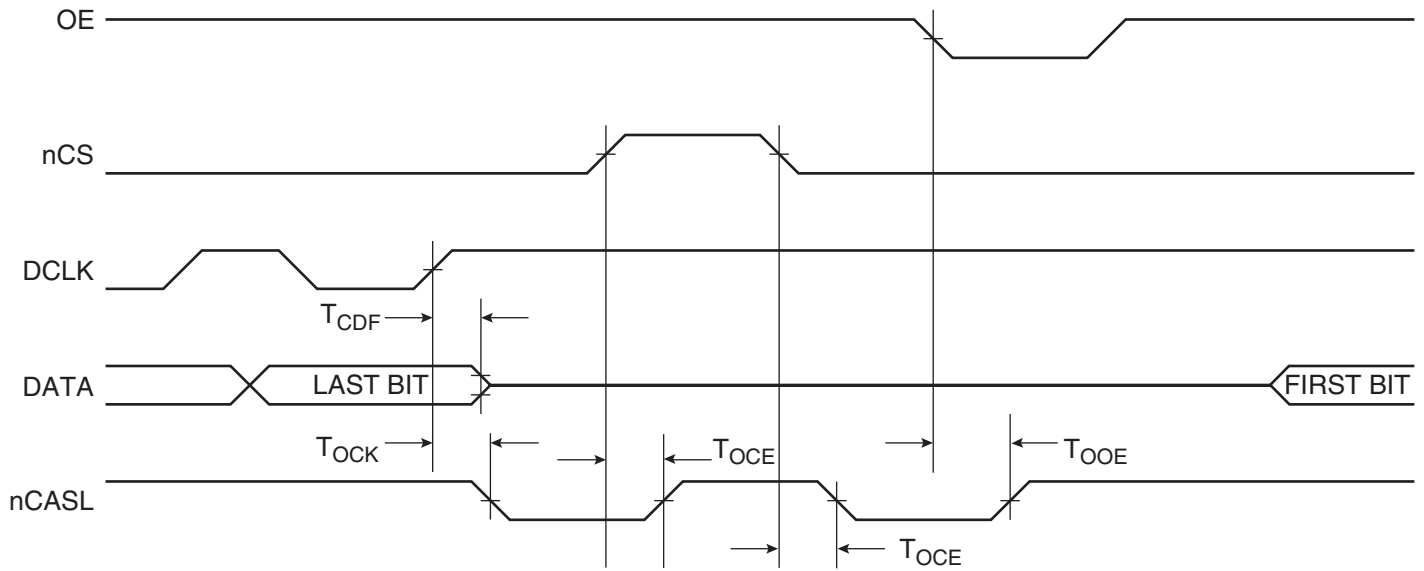

## AC Characteristics for AT17C512A/010A

$V_{CC} = 5V \pm 5\%$  Commercial/ $V_{CC} = 5V \pm 10\%$  Industrial/Military

Symbol	Description	Commercial		Industrial/Military <sup>(1)</sup>		Units
		Min	Max	Min	Max	
$T_{OE}^{(2)}$	OE to Data Delay		30		35	ns
$T_{CE}^{(2)}$	nCS to Data Delay		45		45	ns
$T_{CAC}^{(2)}$	DCLK to Data Delay		50		55	ns
$T_{OH}$	Data Hold From nCS, OE, or DCLK	0		0		ns
$T_{DF}^{(3)}$	nCS or OE to Data Float Delay		50		50	ns
$T_{LC}$	DCLK Low Time Slave Mode	20		20		ns
$T_{HC}$	DCLK High Time Slave Mode	20		20		ns
$T_{SCE}$	nCS Setup Time to DCLK (to guarantee proper counting)	20		25		ns
$T_{HCE}$	nCS Hold Time from DCLK (to guarantee proper counting)	0		0		ns
$T_{LOE}$	OE Low Time (guarantees counter is reset)	20		20		ns
$F_{MAX}$	Maximum Input Clock Frequency Slave Mode	15		15		MHz
$T_{LC}$	DCLK Low Time Master Mode	30	250	30	250	ns
$T_{HC}$	DCLK High Time Master Mode	30	250	30	250	ns

- Notes:
1. Preliminary specifications for military operating range only.
  2. AC test load = 50 pF.
  3. Float delays are measured with 5 pF AC loads. Transition is measured  $\pm 200$  mV from steady state active levels.

## AC Characteristics for AT17C512A/010A When Cascading

$V_{CC} = 5V \pm 5\%$  Commercial/ $V_{CC} = 5V \pm 10\%$  Industrial/Military

Symbol	Description	Commercial		Industrial/Military <sup>(1)</sup>		Units
		Min	Max	Min	Max	
$T_{CDF}^{(3)}$	DCLK to Data Float Delay		50		50	ns
$T_{OCK}^{(2)}$	DCLK to nCASC Delay		35		40	ns
$T_{OCE}^{(2)}$	nCS to nCASC Delay		35		35	ns
$T_{OOE}^{(2)}$	OE to nCASC Delay		30		30	ns
$F_{MAX}$	Maximum Input Clock Frequency	12.5		12.5		MHz

- Notes:
1. Preliminary specifications for military operating range only.
  2. AC test load = 50 pF.
  3. Float delays are measured with 5 pF AC loads. Transition is measured  $\pm 200$  mV from steady state active levels.



## AC Characteristics for AT17LV512A/010A

$V_{CC} = 3.3V \pm 10\%$  Commercial/ $V_{CC} = 3.3V \pm 10\%$  Industrial/Military

Symbol	Description	Commercial		Industrial/Military <sup>(1)</sup>		Units
		Min	Max	Min	Max	
$T_{OE}^{(2)}$	OE to Data Delay		50		55	ns
$T_{CE}^{(2)}$	nCS to Data Delay		55		60	ns
$T_{CAC}^{(2)}$	DCLK to Data Delay		60		65	ns
$T_{OH}$	Data Hold From nCS, OE, or DCLK	0		0		ns
$T_{DF}^{(3)}$	nCS or OE to Data Float Delay		50		50	ns
$T_{LC}$	DCLK Low Time Slave Mode	25		25		ns
$T_{HC}$	DCLK High Time Slave Mode	25		25		ns
$T_{SCE}$	nCS Setup Time to DCLK (to guarantee proper counting)	35		40		ns
$T_{HCE}$	nCS Hold Time from DCLK (to guarantee proper counting)	0		0		ns
$T_{LOE}$	OE Low Time (guarantees counter is reset)	20		20		ns
$F_{MAX}$	Maximum Input Clock Frequency Slave Mode	15		10		MHz
$T_{LC}$	DCLK Low Time Master Mode	30	300	30	300	ns
$T_{HC}$	DCLK High Time Master Mode	30	300	30	300	ns
$V_{RDY}$	Ready Pin Open Collector Voltage	1.2	2.4	1.2	2.4	V

- Notes: 1. Preliminary specifications for military operating range only.  
 2. AC test load = 50 pF.  
 3. Float delays are measured with 5 pF AC loads. Transition is measured  $\pm 200$  mV from steady state active levels.

## AC Characteristics for AT17LV512A/010A When Cascading

$V_{CC} = 3.3V \pm 10\%$  Commercial/ $V_{CC} = 3.3V \pm 10\%$  Industrial/Military

Symbol	Description	Commercial		Industrial/Military <sup>(1)</sup>		Units
		Min	Max	Min	Max	
$T_{CDF}^{(3)}$	DCLK to Data Float Delay		50		50	ns
$T_{OCK}^{(2)}$	DCLK to nCASC Delay		50		55	ns
$T_{OCE}^{(2)}$	nCS to nCASC Delay		35		40	ns
$T_{OOE}^{(2)}$	OE to nCASC Delay		35		35	ns
$F_{MAX}$	Maximum Input Clock Frequency Slave Mode	12.5		10		MHz

- Notes: 1. Preliminary specifications for military operating range only.  
 2. AC test load = 50 pF.  
 3. Float delays are measured with 5 pF AC loads. Transition is measured  $\pm 200$  mV from steady state active levels.

## Ordering Information – 5V Devices

Memory Size	Ordering Code	Package	Operation Range
512-Kbit <sup>(1)</sup>	AT17C512A-10PC AT17C512A-10JC	8P3 20J	Commercial (0°C to 70°C)
	AT17C512A-10PI AT17C512A-10JI	8P3 20J	Industrial (-40°C to 85°C)
1-Mbit <sup>(2)</sup>	AT17C010A-10PC AT17C010A-10JC AT17C010A-10QC	8P3 20J 32A	Commercial (0°C to 70°C)
	AT17C010A-10PI AT17C010A-10JI AT17C010A-10QI	8P3 20J 32A	Industrial (-40°C to 85°C)

Notes: 1. Use 512-Kbit density parts to replace Altera EPC1441.  
2. Use 1-Mbit density parts to replace Altera EPC1.

## Ordering Information – 3.3V Devices

Memory Size	Ordering Code	Package	Operation Range
512-Kbit <sup>(1)</sup>	AT17LV512A-10PC AT17LV512A-10JC	8P3 20J	Commercial (0°C to 70°C)
	AT17LV512A-10PI AT17LV512A-10JI	8P3 20J	Industrial (-40°C to 85°C)
1-Mbit <sup>(2)</sup>	AT17LV010A-10PC AT17LV010A-10JC AT17LV010A-10QC	8P3 20J 32A	Commercial (0°C to 70°C)
	AT17LV010A-10PI AT17LV010A-10JI AT17LV010A-10QI	8P3 20J 32A	Industrial (-40°C to 85°C)

Notes: 1. Use 512-Kbit density parts to replace Altera EPC1441.  
2. Use 1-Mbit density parts to replace Altera EPC1.

Package Type	
<b>8P3</b>	8-lead, 0.300" Wide, Plastic Dual Inline Package (PDIP)
<b>20J</b>	20-lead, Plastic J-leaded Chip Carrier (PLCC)
<b>32A</b>	32-lead, Thin (1.0 mm) Plastic Gull Wing Quad Flat Package (TQFP)

## Packaging Information

### 8P3, 8-lead, 0.300" Wide, Plastic Dual In Line Package (PDIP)

Dimensions in Inches and (Millimeters)  
JEDEC STANDARD MS-018 AA

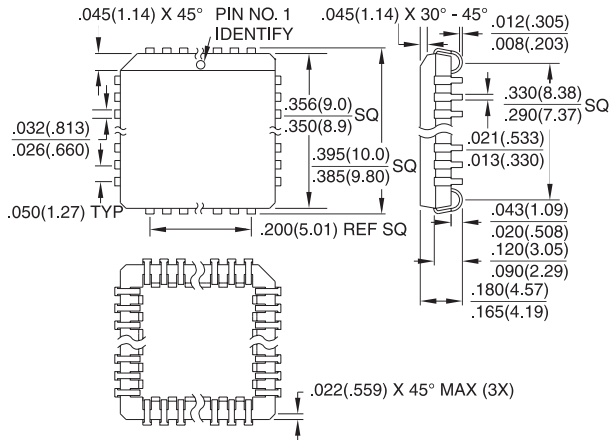

### 20J, 20-lead, Plastic J-leaded Chip Carrier (PLCC)

Dimensions in Inches and (Millimeters)

JEDEC STANDARD MS-018 AA

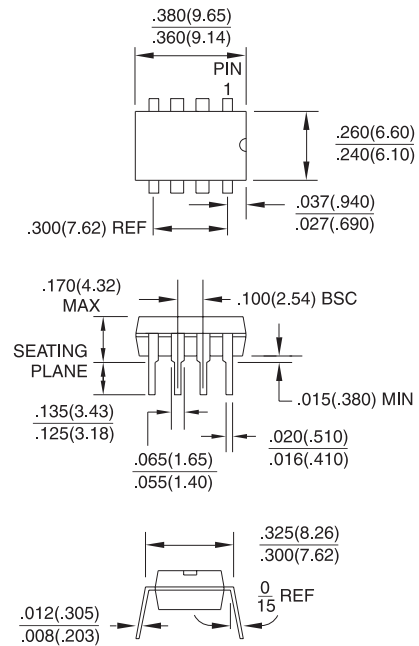

### 32A, 32-lead, Thin (1.0 mm) Plastic Gull Wing Quad Flat package (TQFP)

Dimensions in Millimeters and (Inches)

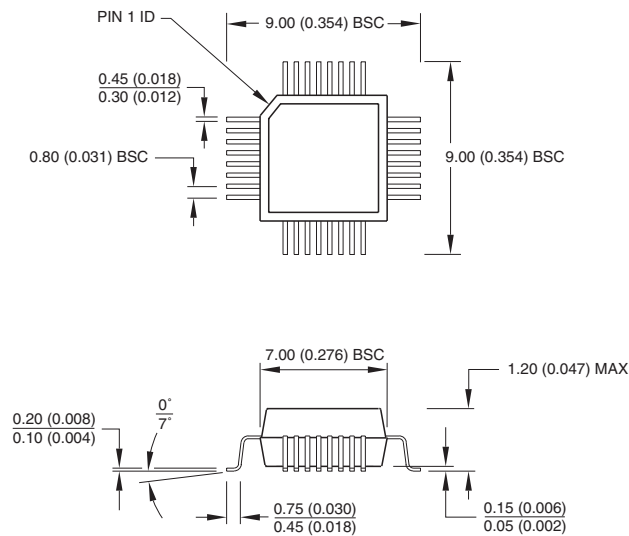



## Atmel Headquarters

*Corporate Headquarters*  
2325 Orchard Parkway  
San Jose, CA 95131  
TEL (408) 441-0311  
FAX (408) 487-2600

### *Europe*

Atmel SarL  
Route des Arsenaux 41  
Casa Postale 80  
CH-1705 Fribourg  
Switzerland  
TEL (41) 26-426-5555  
FAX (41) 26-426-5500

### *Asia*

Atmel Asia, Ltd.  
Room 1219  
Chinachem Golden Plaza  
77 Mody Road Tsimhatsui  
East Kowloon  
Hong Kong  
TEL (852) 2721-9778  
FAX (852) 2722-1369

### *Japan*

Atmel Japan K.K.  
9F, Tonetsu Shinkawa Bldg.  
1-24-8 Shinkawa  
Chuo-ku, Tokyo 104-0033  
Japan  
TEL (81) 3-3523-3551  
FAX (81) 3-3523-7581

## Atmel Product Operations

### *Atmel Colorado Springs*

1150 E. Cheyenne Mtn. Blvd.  
Colorado Springs, CO 80906  
TEL (719) 576-3300  
FAX (719) 540-1759

### *Atmel Grenoble*

Avenue de Rochepleine  
BP 123  
38521 Saint-Egreve Cedex, France  
TEL (33) 4-7658-3000  
FAX (33) 4-7658-3480

### *Atmel Heilbronn*

Theresienstrasse 2  
POB 3535  
D-74025 Heilbronn, Germany  
TEL (49) 71 31 67 25 94  
FAX (49) 71 31 67 24 23

### *Atmel Nantes*

La Chantrerie  
BP 70602  
44306 Nantes Cedex 3, France  
TEL (33) 0 2 40 18 18 18  
FAX (33) 0 2 40 18 19 60

### *Atmel Rousset*

Zone Industrielle  
13106 Rousset Cedex, France  
TEL (33) 4-4253-6000  
FAX (33) 4-4253-6001

### *Atmel Smart Card ICs*

Scottish Enterprise Technology Park  
East Kilbride, Scotland G75 0QR  
TEL (44) 1355-357-000  
FAX (44) 1355-242-743

---

*Atmel Configurator Hotline*  
(408) 436-4119

*Atmel Configurator e-mail*  
configurator@atmel.com

*FAQ*  
Available on web site

*Fax-on-Demand*  
North America:  
1-(800) 292-8635  
International:  
1-(408) 441-0732

*e-mail*  
literature@atmel.com

*Web Site*  
<http://www.atmel.com>

*BBS*  
1-(408) 436-4309

### © Atmel Corporation 2001.

Atmel Corporation makes no warranty for the use of its products, other than those expressly contained in the Company's standard warranty which is detailed in Atmel's Terms and Conditions located on the Company's web site. The Company assumes no responsibility for any errors which may appear in this document, reserves the right to change devices or specifications detailed herein at any time without notice, and does not make any commitment to update the information contained herein. No licenses to patents or other intellectual property of Atmel are granted by the Company in connection with the sale of Atmel products, expressly or by implication. Atmel's products are not authorized for use as critical components in life support devices or systems.

Atmel® is the registered trademark of Atmel.

FLEX® is the registered trademark of Altera Corporation.

Other terms and product names may be the trademarks of others.



Printed on recycled paper.

## Looking for pricing, stock, or lifecycle information?

Click below to explore more details on WIN SOURCE:

- ⊖ [View AT17C512A-10JC on WIN SOURCE](#)
- ⊖ [Microchip Technology Information](#)

## Optimize Your Supply Chain with WIN SOURCE Solutions

- ✓ Global Sourcing Solution
- ✓ Obsolete Management
- ✓ Cost Control Management
- ✓ Shortage Management
- ✓ Alternative Solution
- ✓ Excess Inventory Management