



**THE DATASHEET OF
ISO7341CDWR**



ISO734x Robust EMC, Low-Power, Quad-Channel Digital Isolators

1 Features

- Signaling Rate: 25 Mbps
- Integrated Noise Filter on the Inputs
- Default Output *High* and *Low* Options
- Low Power Consumption, Typical I_{CC} per Channel at 1 Mbps:
 - ISO7340x: 0.9 mA (5-V Supplies), 0.7 mA (3.3-V Supplies)
 - ISO7341x: 1.2 mA (5-V Supplies), 0.9 mA (3.3-V Supplies)
 - ISO7342x: 1.3 mA (5-V Supplies), 0.9 mA (3.3-V Supplies)
- Low Propagation Delay: 31 ns Typical (5-V Supplies)
- 3.3-V and 5-V Level Translation
- Wide Temperature Range: -40°C to 125°C
- 70-KV/ μs Transient Immunity, Typical (5-V Supplies)
- Robust Electromagnetic Compatibility (EMC)
 - System-level ESD, EFT, and Surge Immunity
 - Low Emissions
- Operates from 3.3-V and 5-V Supplies
- Wide-Body SOIC-16 Package
- Safety-Related Certifications:
 - 4242- V_{PK} Basic Isolation per DIN V VDE V 0884-10 and DIN EN 61010-1
 - 3-KV $_{RMS}$ Isolation for 1 minute per UL 1577
 - CSA Component Acceptance Notice 5A, IEC 60950-1 and IEC 61010-1 End Equipment Standards
 - GB4943.1-2011 CQC Certified

2 Applications

- Optocoupler Replacement in:
 - Industrial Fieldbus
 - Profibus
 - Modbus
 - DeviceNet Data Buses
 - Servo Control Interface
 - Motor Control
 - Power Supplies
 - Battery Packs

3 Description

The ISO734x family of devices provides galvanic isolation up to 3000 V_{RMS} for 1 minute per UL 1577 and 4242 V_{PK} per VDE V 0884-10. These devices have four isolated channels comprised of logic input and output buffers separated by a silicon dioxide (SiO_2) insulation barrier.

The ISO7340x device has four channels in forward direction, the ISO7341x device has three forward and one reverse-direction channels, and the ISO7342x device has two forward and two reverse-direction channels. In case of input power or signal loss, the default output is *low* for devices with suffix *F* and *high* for devices without suffix *F*. See the [Device Functional Modes](#) section for further details.

Device Information⁽¹⁾

PART NUMBER	PACKAGE	BODY SIZE
ISO7340C	SOIC (16)	10.30 mm x 7.50 mm
ISO7340FC		
ISO7341C		
ISO7341FC		
ISO7342C		
ISO7342FC		

(1) For all available packages, see the orderable addendum at the end of the datasheet.

Simplified Schematic

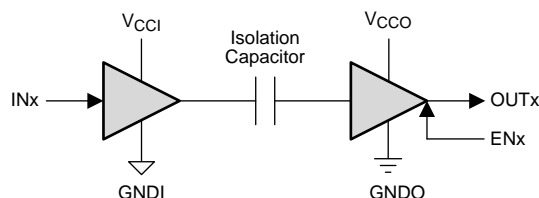

V_{CCI} and $GNDI$ are supply and ground connections respectively for the input channels.

V_{CCO} and $GNDO$ are supply and ground connections respectively for the output.



Table of Contents

1 Features	1	8 Parameter Measurement Information	17
2 Applications	1	9 Detailed Description	19
3 Description	1	9.1 Overview	19
4 Revision History	2	9.2 Functional Block Diagram	19
5 Description (continued)	5	9.3 Feature Description	20
6 Pin Configuration and Functions	6	9.4 Device Functional Modes	21
7 Specifications	7	10 Application and Implementation	22
7.1 Absolute Maximum Ratings	7	10.1 Application Information	22
7.2 ESD Ratings	7	10.2 Typical Application	22
7.3 Recommended Operating Conditions	7	11 Power Supply Recommendations	26
7.4 Thermal Information	8	12 Layout	27
7.5 Power Ratings	8	12.1 Layout Guidelines	27
7.6 Insulation Specifications	9	12.2 Layout Example	27
7.7 Safety-Related Certifications	10	13 Device and Documentation Support	28
7.8 Safety Limiting Values	10	13.1 Documentation Support	28
7.9 Electrical Characteristics—5-V Supply	11	13.2 Related Links	28
7.10 Supply Current Characteristics—5-V Supply	11	13.3 Receiving Notification of Documentation Updates	28
7.11 Electrical Characteristics—3.3-V Supply	12	13.4 Community Resource	28
7.12 Supply Current Characteristics—3.3-V Supply	12	13.5 Trademarks	28
7.13 Switching Characteristics—5-V Supply	13	13.6 Electrostatic Discharge Caution	28
7.14 Switching Characteristics—3.3-V Supply	13	13.7 Glossary	28
7.15 Insulation Characteristics Curves	14	14 Mechanical, Packaging, and Orderable Information	29
7.16 Typical Characteristics	15		

4 Revision History

NOTE: Page numbers for previous revisions may differ from page numbers in the current version.

Changes from Revision F (August 2016) to Revision G

Page

Deleted <i>Reinforced</i> from the data sheet title	1
the <i>production tested</i> note for the UL V_{RMS} value from the <i>Safety-Related Certifications</i>	10

Changes from Revision E (April 2015) to Revision F

Page

Changed the minimum air gap (clearance) parameter (L(I01)) to the external clearance parameter	9
Changed the minimum external tracking (creepage) parameter (L(I02)) to the external creepage parameter	9
Changed the typ value for the enable propagation delay, high impedance-to-high output parameter of the FC devices and the typ value for the enable propagation delay, high impedance-to-low output parameter of the C devices from 16 to 16000 in the <i>Switching Characteristics—3.3-V Supply</i> table	13
Added the <i>Receiving Notification of Documentation Updates</i> section	28

Changes from Revision D (March 2015) to Revision E

Page

Deleted "(VDE V0884-10):2006-12" and "(VDE 0411-1:2011-07)" from the <i>Features Safety and Regulatory Approvals</i> :....	1
Deleted "(Approval Pending)" From the CSA Component Acceptance list item in the <i>Features</i>	1
Deleted IEC from the section title: <i>Insulation and Safety-Related Specifications for DW-16 Package</i>	9
Changed the TEST Conditions of CTI in <i>Insulation and Safety-Related Specifications for DW-16 Package</i>	9
Changed the Test Conditions of V_{ISO} in <i>Insulation Characteristics</i>	9
Changed column CSA in the <i>Safety-Related Certifications</i> table	10
Changed From: V_{CC1} To: V_{CCi} in <i>Switching Characteristics Test Circuit and Voltage Waveforms</i>	17
Changed From: V_{CC1} To: V_{CCi} and From: V_{CC2} To: V_{CCO} in <i>Common-Mode Transient Immunity Test Circuit</i>	18

Changes from Revision C (December 2014) to Revision D	Page
• Changed the DIN V VDE 0884-10 number in the <i>Features Safety and Regulatory Approvals</i> :	1
• Added "(Approval Pending)" to the CSA Component Acceptance list item in the <i>Features</i>	1
• Deleted "All Agencies Approvals Planned" from the <i>Features Safety and Regulatory Approvals</i> :	1
• Changed the Simplified Schematic: V_{CC1} To V_{CC1} , V_{CC2} to V_{CC0} and GND1 to GNDI, GND2 to GNDO. Added Notes 1 and 2.	1
• Added Note: "Maximum voltage must not exceed 6 V:" to <i>Absolute Maximum Ratings</i>	7
• Added "DT1" to the Minimum internal gap in <i>Insulation and Safety-Related Specifications for DW-16 Package</i>	9
• Changed V_{IORM} "Maximum repetitive peak voltage" To: "Maximum repetitive peak isolation voltage per DIN V VDE V 0884-10" in <i>Insulation Characteristics</i>	9
• Changed V_{IOTM} From: "DIN V VDE 0884-10 " To: "DIN V VDE V 0884-10" in <i>Insulation Characteristics</i>	9
• Changed V_{IOSM} "Maximum surge voltage per DIN V VDE 0884-10 " To: "Maximum surge isolation voltage per DIN V VDE V 0884-100" in <i>Insulation Characteristics</i>	9
• Changed V_{IOSM} Test Conditions in <i>Insulation Characteristics</i>	9
• Changed V_{PR} From: "DIN V VDE 0884-10 " To: "DIN V VDE V 0884-10" in <i>Insulation Characteristics</i>	9
• Changed R_S Test Conditions in <i>Insulation and Safety-Related Specifications for DW-16 Package</i> From: T_S To: $T_S = 150^\circ\text{C}$	9
• Changed the <i>Safety-Related Certifications</i> table	10
• Changed title From: " IEC Safety Limiting Values" To: <i>Safety Limiting Values</i>	10
• Changed MIN value for V_{OH} in the <i>Electrical Characteristics</i> From: $V_{CCx} - 0.5$ To: $V_{CC0} - 0.5$	11
• Changed V_{CCx} To V_{CC0} in Note 1 of the <i>Electrical Characteristics</i>	11
• Changed MIN value for V_{OH} in the <i>Electrical Characteristics</i> From: $V_{CCx} - 0.5$ To: $V_{CC0} - 0.5$	12
• Changed V_{CCx} To V_{CC0} in Note 1 of the <i>Electrical Characteristics</i>	12
• Changed <i>Function Table</i> Header information From: INPUT-SIDE V_{CC} To: V_{CC1} and OUTPUT-SIDE V_{CC} To: V_{CC0}	21
• Changed <i>Device I/O Schematics</i> From: V_{CC} To: V_{CC1} on the inputs and V_{CC0} on Output and Enabled.....	21
• Moved <i>Typical ISO7340x Circuit Hook-up</i> to <i>Typical ISO7342x-Q1 Circuit Hook-up</i> from the <i>Design Requirements</i> section to the <i>Detailed Design Procedure</i> section.....	23

Changes from Revision B (November 2014) to Revision C	Page
• Changed the Handling Ratings table to ESD Ratings.....	7
• Changed Minimum internal gap MIN value in <i>Insulation and Safety-Related Specifications for DW-16 Package</i> From: 0.014 mm To: 13.5 μm	9
• Changed Minimum internal gap MIN value in <i>Insulation and Safety-Related Specifications for DW-16 Package</i> From: 13.5 μm To: 13 μm	9
• Delete text "per DIN V VDE 0884-10" from V_{IORM} in the table in section <i>Insulation Characteristics</i>	9
• Changed From: V_{PEAK} To V_{PK} in the UNIT column of the table in section <i>Insulation Characteristics</i>	9
• Added V_{IOSM} to the table in section <i>Insulation Characteristics</i>	9
• Changed the table in <i>Safety-Related Certifications</i> section - removed text "Certified according to", "Approved under", "Recognized under", changed "pending" To: "planned"	10
• Changed Maximum Repetitive Peak Voltage, 1414 V_{PK} To: Maximum surge voltage , 6000 V_{PK} in the VDE column of the table in section <i>Safety-Related Certifications</i>	10
• Changed the I_{CC2} , Supply current, DC to 1 Mbps TYP value From: 3 To 3.2 mA	11
• Changed the I_{CC2} , Supply current, 10 Mbps TYP value From: 5.1 To 5.6 mA	11
• Changed the I_{CC2} , Supply current, 25 Mbps TYP value From: 8.6 To 9.3 mA	11
• Changed the I_{CC1} , Supply current, 10 Mbps TYP value From: 0.8 To 0.9 mA	12
• Changed the I_{CC2} , Supply current, 10 Mbps TYP value From: 0.3.6 To 3.9 mA	12
• Changed the I_{CC2} , Supply current, 25 Mbps TYP value From: 5.9 To 6.3 mA	12

ISO7340C, ISO7340FC, ISO7341C, ISO7341FC, ISO7342C, ISO7342FC

SLLSEI6G – SEPTEMBER 2014 – REVISED JANUARY 2017

www.ti.com

-
- Added *ISO7340 Supply Current vs Data Rate (15-pF Load)* and *ISO7340x Supply Current vs Data Rate (No Load)*..... 15
 - Changed *ISO7341x Supply Current vs Data Rate (No Load)*..... 15
-

Changes from Revision A (October 2014) to Revision B
Page

-
- Added Test Condition to *IEC 60664-1 Ratings Table*: Rated mains voltage $\leq 1000 V_{RMS}$ 9
 - Changed the R_{IO} Test Conditions in *Insulation and Safety-Related Specifications for DW-16 Package* : Added $T_A = 25^\circ\text{C}$ at $\text{MIN} = 10^{12}$ 9
 - Changed the R_{IO} Test Conditions in *Insulation and Safety-Related Specifications for DW-16 Package* : Added $V_{IO} = 500 \text{ V}$, $100^\circ\text{C} \leq T_A \leq 125^\circ\text{C}$ at $\text{MIN} = 10^{11}$ 9
 - Added *ISO7341x Supply Current vs Data Rate (15-pF Load)* and *ISO7341x Supply Current vs Data Rate (No Load)*..... 15
-

Changes from Original (September 2014) to Revision A
Page

-
- Changed From a 1 page Product Preview to the full datasheet 1
 - Changed the *Simplified Schematic*, added ground symbols 1
-

5 Description (continued)

Used in conjunction with isolated power supplies, these devices help prevent noise currents on a data bus or other circuits from entering the local ground and interfering with or damaging sensitive circuitry. The ISO734x device has integrated noise filter for harsh industrial environment where short noise pulses may be present at the device input pins. The ISO734x device has TTL input thresholds and operates from 3-V to 5.5-V supply levels. Through innovative chip design and layout techniques, electromagnetic compatibility of the ISO734x family of devices has been significantly enhanced to enable system-level ESD, EFT, surge, and emissions compliance.

6 Pin Configuration and Functions

**DW Package
16-Pin SOIC
ISO7340x Top View**

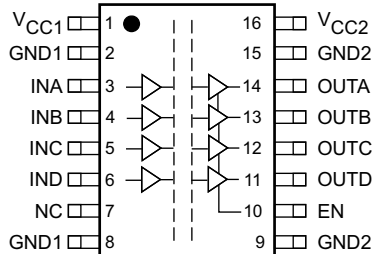

**DW Package
16-Pin SOIC
ISO7341x Top View**

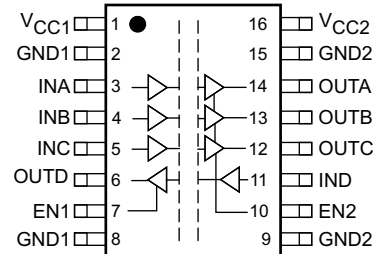

**DW Package
16-Pin SOIC
ISO7342x Top View**

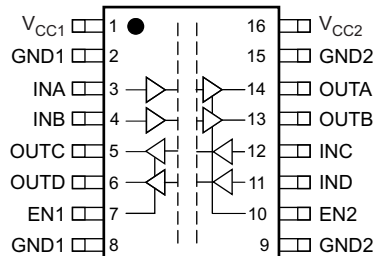

Pin Functions

NAME	PIN			I/O	DESCRIPTION
	NO.				
	ISO7340x	ISO7341x	ISO7342x		
EN	10	—	—	I	Output enable. All output pins are enabled when EN is high or disconnected and disabled when EN is low.
EN1	—	7	7	I	Output enable 1. Output pins on side-1 are enabled when EN1 is high or disconnected and disabled when EN1 is low.
EN2	—	10	10	I	Output enable 2. Output pins on side-2 are enabled when EN2 is high or disconnected and disabled when EN2 is low.
GND1	2	2	2	—	Ground connection for V_{CC1}
	8	8	8		
GND2	9	9	9	—	Ground connection for V_{CC2}
	15	15	15		
INA	3	3	3	I	Input, channel A
INB	4	4	4	I	Input, channel B
INC	5	5	12	I	Input, channel C
IND	6	11	11	I	Input, channel D
NC	7	—	—	—	No connect pins are floating with no internal connection
OUTA	14	14	14	O	Output, channel A
OUTB	13	13	13	O	Output, channel B
OUTC	12	12	5	O	Output, channel C
OUTD	11	6	6	O	Output, channel D
V_{CC1}	1	1	1	—	Power supply, V_{CC1}
V_{CC2}	16	16	16	—	Power supply, V_{CC2}

7 Specifications

7.1 Absolute Maximum Ratings

 See ⁽¹⁾

			MIN	MAX	UNIT
V _{CC}	Supply voltage ⁽²⁾	V _{CC1} , V _{CC2}	-0.5	6	V
	Voltage	IN _x , OUT _x , EN _x	-0.5	V _{CC} + 0.5 ⁽³⁾	V
I _O	Output current			±15	mA
T _J	Maximum junction temperature			150	°C
T _{stg}	Storage temperature		-65	150	°C

- (1) Stresses beyond those listed under *absolute maximum ratings* may cause permanent damage to the device. These are stress ratings only and functional operation of the device at these or any other conditions beyond those indicated under *Recommended Operating Conditions* is not implied. Exposure to absolute-maximum-rated conditions for extended periods may affect device reliability.
- (2) All voltage values except differential I/O bus voltages are with respect to the local ground terminal (GND1 or GND2) and are peak voltage values.
- (3) Maximum voltage must not exceed 6 V.

7.2 ESD Ratings

			VALUE	UNIT
V _(ESD)	Electrostatic discharge	Human body model (HBM), per ANSI/ESDA/JEDEC JS-001 ⁽¹⁾	±4000	V
		Charged device model (CDM), per JEDEC specification JESD22-C101 ⁽²⁾	±1500	V

- (1) JEDEC document JEP155 states that 500-V HBM allows safe manufacturing with a standard ESD control process.
- (2) JEDEC document JEP157 states that 250-V CDM allows safe manufacturing with a standard ESD control process.

7.3 Recommended Operating Conditions

			MIN	NOM	MAX	UNIT
V _{CC1} , V _{CC2}	Supply voltage		3		5.5	V
I _{OH}	High-level output current		-4			mA
I _{OL}	Low-level output current				4	mA
V _{IH}	High-level input voltage		2		5.5	V
V _{IL}	Low-level input voltage		0		0.8	V
t _{ui}	Input pulse duration		40			ns
1 / t _{ui}	Signaling rate		0		25	Mbps
T _J	Junction temperature ⁽¹⁾				136	°C
T _A	Ambient temperature		-40	25	125	°C

- (1) To maintain the recommended operating conditions for T_J, see the [Thermal Information](#) table.

7.4 Thermal Information

THERMAL METRIC ⁽¹⁾		ISO734x	UNIT
		DW (SOIC)	
		16 PINS	
$R_{\theta JA}$	Junction-to-ambient thermal resistance	78.4	°C/W
$R_{\theta JC(top)}$	Junction-to-case(top) thermal resistance	41	°C/W
$R_{\theta JB}$	Junction-to-board thermal resistance	43	°C/W
Ψ_{JT}	Junction-to-top characterization parameter	15.6	°C/W
Ψ_{JB}	Junction-to-board characterization parameter	42.5	°C/W
$R_{\theta JC(bottom)}$	Junction-to-case(bottom) thermal resistance	n/a	°C/W

(1) For more information about traditional and new thermal metrics, see the [Semiconductor and IC Package Thermal Metrics](#) application report.

7.5 Power Ratings

$V_{CC1} = V_{CC2} = 5.5\text{ V}$, $T_J = 150^\circ\text{C}$, $C_L = 15\text{ pF}$, Input a 12.5-MHz 50% duty cycle square wave

PARAMETER		TEST CONDITIONS	MIN	TYP	MAX	UNIT
P_D	Maximum power dissipation by both sides of ISO7340x				92	mW
P_{D1}	Maximum power dissipation by side-1 of ISO7340x				24	
P_{D2}	Maximum power dissipation by side-2 of ISO7340x				68	
P_D	Maximum power dissipation by both sides of ISO7341x				102	mW
P_{D1}	Maximum power dissipation by side-1 of ISO7341x				42	
P_{D2}	Maximum power dissipation by side-2 of ISO7341x				60	
P_D	Maximum power dissipation by both sides of ISO7342x				111	mW
P_{D1}	Maximum power dissipation by side-1 of ISO7342x				55.5	
P_{D2}	Maximum power dissipation by side-2 of ISO7342x				55.5	

7.6 Insulation Specifications

PARAMETER		TEST CONDITIONS	VALUE	UNIT
GENERAL				
CLR	External clearance ⁽¹⁾	Shortest terminal-to-terminal distance through air	>8	mm
CPG	External creepage ⁽¹⁾	Shortest terminal-to-terminal distance across the package surface	>8	mm
DTI	Distance through the insulation	Minimum internal gap (internal clearance)	>13	μm
CTI	Comparative tracking index	DIN EN 60112 (VDE 0303-11); IEC 60112	>400	V
	Material group		II	
	Overvoltage Category	Rated mains voltage ≤ 300 V _{RMS}	I–IV	
		Rated mains voltage ≤ 600 V _{RMS}	I–III	
		Rated mains voltage ≤ 1000 V _{RMS}	I–II	
DIN V VDE V 0884-10 (VDE V 0884-10):2006-12⁽²⁾				
V _{IORM}	Maximum repetitive peak isolation voltage	AC voltage (bipolar)	1414	V _{PK}
V _{IOTM}	Maximum transient isolation voltage	V _{TEST} = V _{IOTM} ; t = 60 s (qualification); t = 1 s (100% production)	4242	V _{PK}
V _{IOSM}	Maximum surge isolation voltage ⁽³⁾	Test method per IEC 60065, 1.2/50 μs waveform, V _{TEST} = 1.3 × V _{IOSM} = 7800 V _{PK} (qualification)	6000	V _{PK}
q _{pd}	Apparent charge ⁽⁴⁾	Method a: After I/O safety test subgroup 2/3, V _{ini} = V _{IOTM} , t _{ini} = 60 s; V _{pd(m)} = 1.2 × V _{IORM} = 1697 V _{PK} , t _m = 10 s	≤5	pC
		Method a: After environmental tests subgroup 1, V _{ini} = V _{IOTM} , t _{ini} = 60 s; V _{pd(m)} = 1.6 × V _{IORM} = 2262 V _{PK} , t _m = 10 s	≤5	
		Method b1: At routine test (100% production) and preconditioning (type test) V _{ini} = V _{IOTM} , t _{ini} = 1 s; V _{pd(m)} = 1.875 × V _{IORM} = 2651 V _{PK} , t _m = 1 s (100% production)	≤5	
C _{IO}	Barrier capacitance, input to output ⁽⁵⁾	V _{IO} = 0.4 sin(2πft), f = 1 MHz	2.4	pF
R _{IO}	Isolation resistance, input to output ⁽⁵⁾	V _{IO} = 500 V, T _A = 25°C	>10 ¹²	Ω
		V _{IO} = 500 V, 100°C ≤ T _A ≤ x°C	>10 ¹¹	
		V _{IO} = 500 V at T _S = 150°C	>10 ⁹	
	Pollution degree		2	
	Climatic category		40/125/21	
UL 1577				
V _{ISO}	Withstand isolation voltage	V _{TEST} = V _{ISO} = 3000 V _{RMS} , t = 60 s (qualification); V _{TEST} = 1.2 × V _{ISO} = 3600 V _{RMS} , t = 1 s (100% production)	3000	V _{RMS}

- (1) Creepage and clearance requirements should be applied according to the specific equipment isolation standards of an application. Care should be taken to maintain the creepage and clearance distance of a board design to ensure that the mounting pads of the isolator on the printed-circuit board do not reduce this distance. Creepage and clearance on a printed-circuit board become equal in certain cases. Techniques such as inserting grooves and/or ribs on a printed circuit board are used to help increase these specifications.
- (2) This coupler is suitable for *safe electrical insulation* only within the maximum operating ratings. Compliance with the safety ratings shall be ensured by means of suitable protective circuits.
- (3) Testing is carried out in air or oil to determine the intrinsic surge immunity of the isolation barrier.
- (4) Apparent charge is electrical discharge caused by a partial discharge (pd).
- (5) All pins on each side of the barrier tied together creating a two-terminal device

7.7 Safety-Related Certifications

VDE	CSA	UL	CQC
Certified according to DIN V VDE V 0884-10 (VDE V 0884-10):2006-12 and DIN EN 61010-1 (VDE 0411-1):2011-07	Approved under CSA Component Acceptance Notice 5A, IEC 60950-1, and IEC 61010-1	Recognized under UL 1577 Component Recognition Program	Certified according to GB4943.1-2011
Basic Insulation; Maximum Transient Overvoltage, 4242 V _{PK} ; Maximum Surge Isolation Voltage, 6000 V _{PK} ; Maximum Repetitive Peak Isolation Voltage, 1414 V _{PK}	800 V _{RMS} Basic Insulation and 400 V _{RMS} Reinforced Insulation working voltage per CSA 60950-1-07+A1+A2 and IEC 60950-1 2nd Ed.+A1+A2; 300 V _{RMS} Basic Insulation working voltage per CSA 61010-1-12 and IEC 61010-1 3rd Ed.	Single protection, 3000 V _{RMS}	Reinforced Insulation, Altitude ≤ 5000 m, Tropical Climate, 250 V _{RMS} maximum working voltage
Certificate number: 40016131	Master contract number: 220991	File number: E181974	Certificate number: CQC15001121716

7.8 Safety Limiting Values

Safety limiting intends to minimize potential damage to the isolation barrier upon failure of input or output circuitry. A failure of the I/O can allow low resistance to ground or the supply and, without current limiting, dissipate sufficient power to overheat the die and damage the isolation barrier, potentially leading to secondary system failures.

PARAMETER		TEST CONDITIONS	MIN	TYP	MAX	UNIT
I _S	Safety input, output, or supply current	R _{θJA} = 78.4 °C/W, V _I = 5.5 V, T _J = 150°C, T _A = 25°C, see Figure 1			290	mA
		R _{θJA} = 78.4 °C/W, V _I = 3.6 V, T _J = 150°C, T _A = 25°C, see Figure 1			443	
T _S	Safety temperature				150	

The safety-limiting constraint is the maximum junction temperature specified in the data sheet. The power dissipation and junction-to-air thermal impedance of the device installed in the application hardware determines the junction temperature. The assumed junction-to-air thermal resistance in the [Thermal Information](#) table is that of a device installed on a high-K test board for leaded surface-mount packages. The power is the recommended maximum input voltage times the current. The junction temperature is then the ambient temperature plus the power times the junction-to-air thermal resistance.

7.9 Electrical Characteristics—5-V Supply

V_{CC1} and V_{CC2} at 5 V \pm 10% (over recommended operating conditions unless otherwise noted)

PARAMETER	TEST CONDITIONS	MIN	TYP	MAX	UNIT
V_{OH} High-level output voltage	$I_{OH} = -4$ mA; see Figure 14	$V_{CCO}^{(1)} - 0.5$	4.7		V
	$I_{OH} = -20$ μ A; see Figure 14	$V_{CCO}^{(1)} - 0.1$	5		
V_{OL} Low-level output voltage	$I_{OL} = 4$ mA; see Figure 14		0.2	0.4	V
	$I_{OL} = 20$ μ A; see Figure 14		0	0.1	
$V_{I(HYS)}$ Input threshold voltage hysteresis			480		mV
I_{IH} High-level input current	$V_{IH} = V_{CC}$ at INx or ENx			10	μ A
I_{IL} Low-level input current	$V_{IL} = 0$ V at INx or ENx	-10			μ A
CMTI Common-mode transient immunity	$V_I = V_{CC}$ or 0 V; see Figure 17	25	70		kV/ μ s
C_I Input capacitance ⁽²⁾	$V_I = V_{CC}/2 + 0.4 \sin(2\pi ft)$, $f = 1$ MHz, $V_{CC} = 5$ V		3.4		pF

(1) V_{CCO} is supply voltage, V_{CC1} or V_{CC2} , for the output channel being measured.

(2) Measured from input pin to ground.

7.10 Supply Current Characteristics—5-V Supply

All inputs switching with square wave clock signal for dynamic I_{CC} measurement. V_{CC1} and V_{CC2} at 5 V \pm 10% (over recommended operating conditions unless otherwise noted)

PARAMETER	TEST CONDITIONS	SUPPLY CURRENT	MIN	TYP	MAX	UNIT
ISO7340x						
Supply current	EN = 0 V	Disable	I_{CC1}	0.6	1.4	mA
			I_{CC2}	0.4	0.8	
	DC Signal: $V_I = V_{CC}$ or 0 V, AC Signal: All channels switching with square wave clock input; $C_L = 15$ pF	DC to 1 Mbps	I_{CC1}	0.6	1.4	
			I_{CC2}	3.2	4.8	
		10 Mbps	I_{CC1}	1.4	2.3	
			I_{CC2}	5.6	7.1	
		25 Mbps	I_{CC1}	2.7	4	
			I_{CC2}	9.3	12	
ISO7341x						
Supply current	EN1 = EN2 = 0 V	Disable	I_{CC1}	0.8	1.8	mA
			I_{CC2}	0.7	1.3	
	DC Signal: $V_I = V_{CC}$ or 0 V, AC Signal: All channels switching with square wave clock input; $C_L = 15$ pF	DC to 1 Mbps	I_{CC1}	2	3.2	
			I_{CC2}	2.9	4.4	
		10 Mbps	I_{CC1}	3.2	4.5	
			I_{CC2}	4.9	6.5	
		25 Mbps	I_{CC1}	5	7	
			I_{CC2}	7.8	11	
ISO7342x						
Supply current	EN1 = EN2 = 0 V	Disable	I_{CC1}, I_{CC2}	0.7	1.6	mA
			DC to 1 Mbps	I_{CC1}, I_{CC2}	2.5	
	DC Signal: $V_I = V_{CC}$ or 0 V, AC Signal: All channels switching with square wave clock input; $C_L = 15$ pF	10 Mbps	I_{CC1}, I_{CC2}	4.1	5.6	
		25 Mbps	I_{CC1}, I_{CC2}	6.4	9	

7.11 Electrical Characteristics—3.3-V Supply

 V_{CC1} and V_{CC2} at 3.3 V \pm 10% (over recommended operating conditions unless otherwise noted)

PARAMETER	TEST CONDITIONS	MIN	TYP	MAX	UNIT
V_{OH} High-level output voltage	$I_{OH} = -4$ mA; see Figure 14	$V_{CCO}^{(1)} - 0.5$	3		V
	$I_{OH} = -20$ μ A; see Figure 14	$V_{CCO}^{(1)} - 0.1$	3.3		
V_{OL} Low-level output voltage	$I_{OL} = 4$ mA; see Figure 14		0.2	0.4	V
	$I_{OL} = 20$ μ A; see Figure 14		0	0.1	
$V_{I(HYS)}$ Input threshold voltage hysteresis			450		mV
I_{IH} High-level input current	$V_{IH} = V_{CC}$ at INx or ENx			10	μ A
I_{IL} Low-level input current	$V_{IL} = 0$ V at INx or ENx	-10			μ A
CMTI Common-mode transient immunity	$V_I = V_{CC}$ or 0 V; see Figure 17	25	50		kV/ μ s

 (1) V_{CCO} is supply voltage, V_{CC1} or V_{CC2} , for the output channel being measured.

7.12 Supply Current Characteristics—3.3-V Supply

 All inputs switching with square wave clock signal for dynamic I_{CC} measurement. V_{CC1} and V_{CC2} at 3.3 V \pm 10% (over recommended operating conditions unless otherwise noted)

PARAMETER	TEST CONDITIONS	SUPPLY CURRENT	MIN	TYP	MAX	UNIT
ISO7340x						
Supply current	EN = 0 V	Disable	I_{CC1}	0.4	0.7	mA
			I_{CC2}	0.3	0.6	
	DC Signal: $V_I = V_{CC}$ or 0 V, AC Signal: All channels switching with square wave clock input; $C_L = 15$ pF	DC to 1 Mbps	I_{CC1}	0.4	0.7	
			I_{CC2}	2.3	3.6	
		10 Mbps	I_{CC1}	0.9	1.3	
			I_{CC2}	3.9	5.1	
		25 Mbps	I_{CC1}	1.6	2.4	
			I_{CC2}	6.3	8	
ISO7341x						
Supply current	EN1 = EN2 = 0 V	Disable	I_{CC1}	0.6	1	mA
			I_{CC2}	0.5	0.8	
	DC Signal: $V_I = V_{CC}$ or 0 V, AC Signal: All channels switching with square wave clock input; $C_L = 15$ pF	DC to 1 Mbps	I_{CC1}	1.4	2.3	
			I_{CC2}	2.2	3.2	
		10 Mbps	I_{CC1}	2.2	3	
			I_{CC2}	3.4	4.5	
		25 Mbps	I_{CC1}	3.3	4.7	
			I_{CC2}	5.2	7.2	
ISO7342x						
Supply current	EN1 = EN2 = 0 V	Disable	I_{CC1}, I_{CC2}	0.5	0.9	mA
		DC to 1 Mbps	I_{CC1}, I_{CC2}	1.8	2.8	
	DC Signal: $V_I = V_{CC}$ or 0 V, AC Signal: All channels switching with square wave clock input; $C_L = 15$ pF	10 Mbps	I_{CC1}, I_{CC2}	2.8	4	
		25 Mbps	I_{CC1}, I_{CC2}	4.3	5.8	

7.13 Switching Characteristics—5-V Supply

V_{CC1} and V_{CC2} at 5 V \pm 10% (over recommended operating conditions unless otherwise noted)

PARAMETER		TEST CONDITIONS	MIN	TYP	MAX	UNIT	
t_{PLH} , t_{PHL}	Propagation delay time	See Figure 14	20	31	58	ns	
PWD ⁽¹⁾	Pulse width distortion $ t_{PHL} - t_{PLH} $				4	ns	
$t_{sk(o)}$ ⁽²⁾	Channel-to-channel output skew time	Same-direction Channels			2.5	ns	
		Opposite-direction Channels			17	ns	
$t_{sk(pp)}$ ⁽³⁾	Part-to-part skew time				23	ns	
t_r	Output signal rise time	See Figure 14		2.1		ns	
t_f	Output signal fall time			1.7		ns	
t_{PHZ}	Disable propagation delay, high-to-high impedance output	See Figure 15		7	13	ns	
t_{PLZ}	Disable propagation delay, low-to-high impedance output			7	13	ns	
t_{PZH}	Enable propagation delay, high impedance-to-high output		ISO734xC		7	13	ns
			ISO734xFC	15000	23000 ⁽⁴⁾		
t_{PZL}	Enable propagation delay, high impedance-to-low output		ISO734xC	15000	23000 ⁽⁴⁾	ns	
			ISO734xFC	7	13		
t_s	Fail-safe output delay time from input power loss	See Figure 16		9.4		μ s	

(1) Also known as *Pulse Skew*.

(2) $t_{sk(o)}$ is the skew between outputs of a single device with all driving inputs connected together and the outputs switching in the same direction while driving identical loads.

(3) $t_{sk(pp)}$ is the magnitude of the difference in propagation delay times between any terminals of different devices switching in the same direction while operating at identical supply voltages, temperature, input signals and loads.

(4) The enable signal rate should be \leq 43 Kbps.

7.14 Switching Characteristics—3.3-V Supply

V_{CC1} and V_{CC2} at 3.3 V \pm 10% (over recommended operating conditions unless otherwise noted)

PARAMETER		TEST CONDITIONS	MIN	TYP	MAX	UNIT	
t_{PLH} , t_{PHL}	Propagation delay time	See Figure 14	22	35	66	ns	
PWD ⁽¹⁾	Pulse width distortion $ t_{PHL} - t_{PLH} $				2.5		
$t_{sk(o)}$ ⁽²⁾	Channel-to-channel output skew time	Same-direction Channels			3	ns	
		Opposite-direction Channels			16		
$t_{sk(pp)}$ ⁽³⁾	Part-to-part skew time				28		
t_r	Output signal rise time	See Figure 14		2.8		ns	
t_f	Output signal fall time			2.1			
t_{PHZ}	Disable propagation delay, high-to-high impedance output	See Figure 15		9	18	ns	
t_{PLZ}	Disable propagation delay, low-to-high impedance output			9	18		
t_{PZH}	Enable propagation delay, high impedance-to-high output		ISO734xC		9		18
			ISO734xFC	16000	24000 ⁽⁴⁾		
t_{PZL}	Enable propagation delay, high impedance-to-low output		ISO734xC	16000	24000 ⁽⁴⁾		
			ISO734xFC	9	18		
t_s	Fail-safe output delay time from input power loss	See Figure 16		9.4		μ s	

(1) Also known as *Pulse Skew*.

(2) $t_{sk(o)}$ is the skew between outputs of a single device with all driving inputs connected together and the outputs switching in the same direction while driving identical loads.

(3) $t_{sk(pp)}$ is the magnitude of the difference in propagation delay times between any terminals of different devices switching in the same direction while operating at identical supply voltages, temperature, input signals and loads.

(4) The enable signal rate should be \leq 45 Kbps.

7.15 Insulation Characteristics Curves

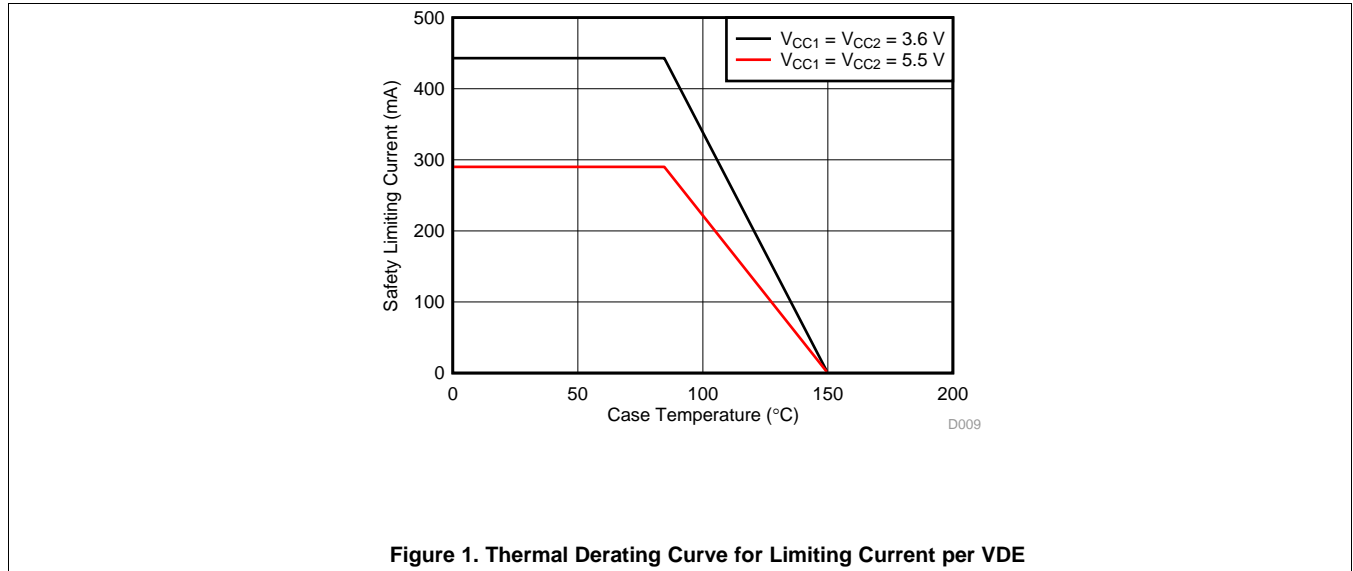

7.16 Typical Characteristics

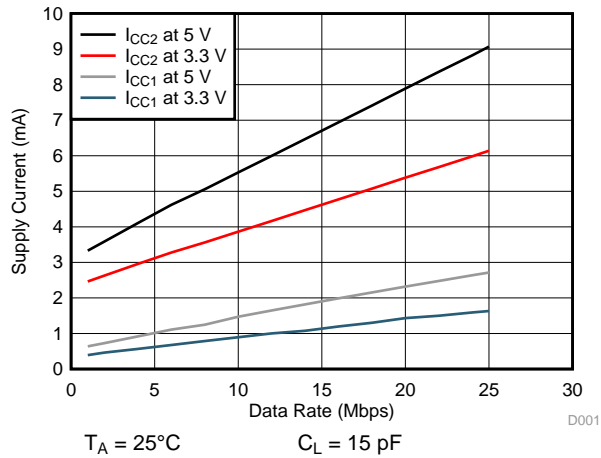

Figure 2. ISO7340x Supply Current vs Data Rate (15-pF Load)

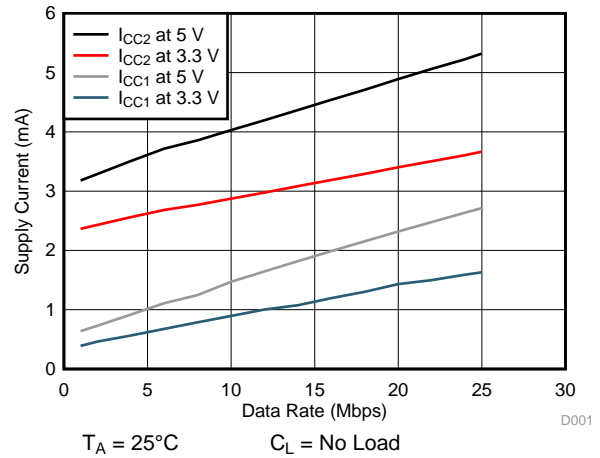

Figure 3. ISO7340x Supply Current vs Data Rate (No Load)

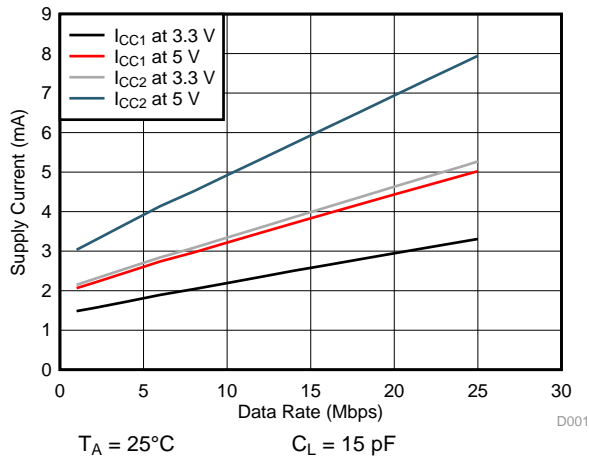

Figure 4. ISO7341x Supply Current vs Data Rate (15-pF Load)

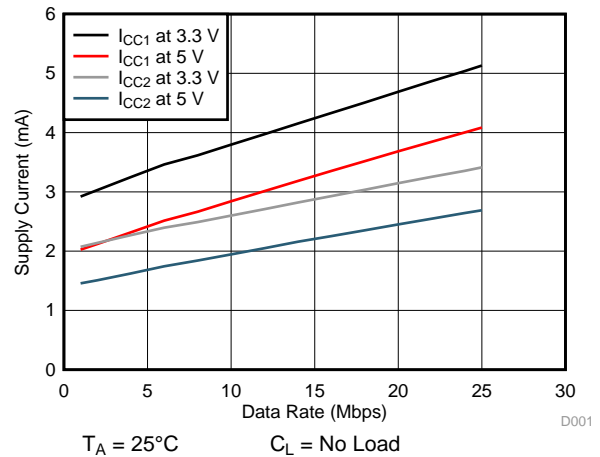

Figure 5. ISO7341x Supply Current vs Data Rate (No Load)

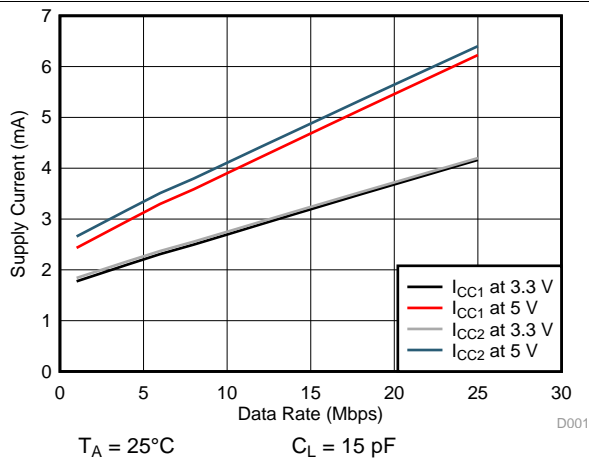

Figure 6. ISO7342x Supply Current vs Data Rate (15-pF Load)

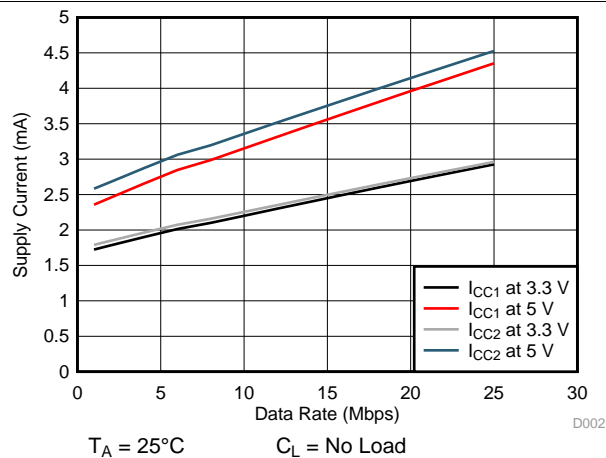

Figure 7. ISO7342x Supply Current vs Data Rate (No Load)

Typical Characteristics (continued)

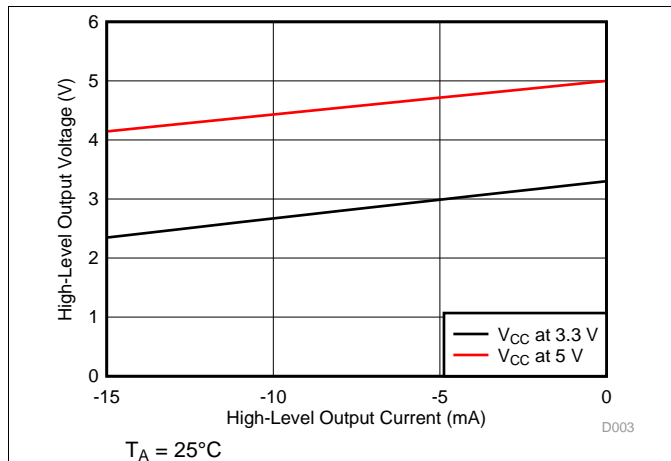

Figure 8. High-Level Output Voltage vs High-level Output Current

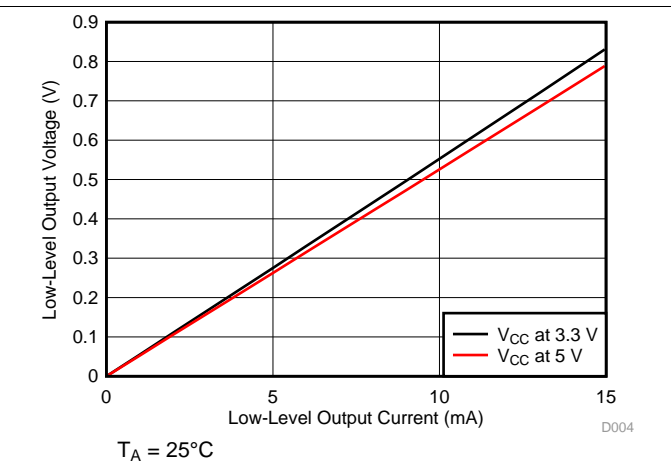

Figure 9. Low-Level Output Voltage vs Low-Level Output Current

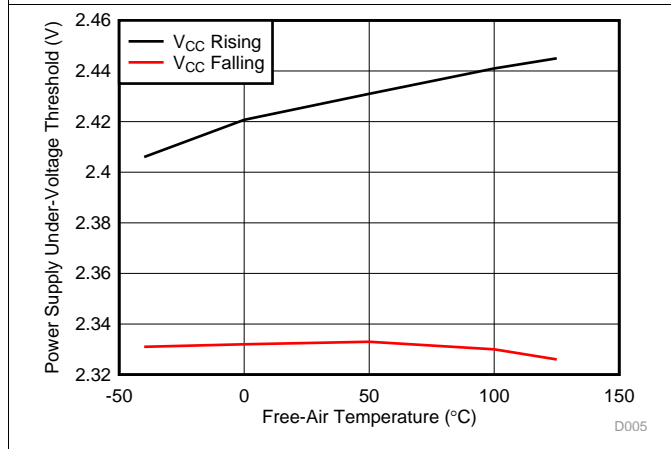

Figure 10. Power Supply Undervoltage Threshold vs Free-Air Temperature

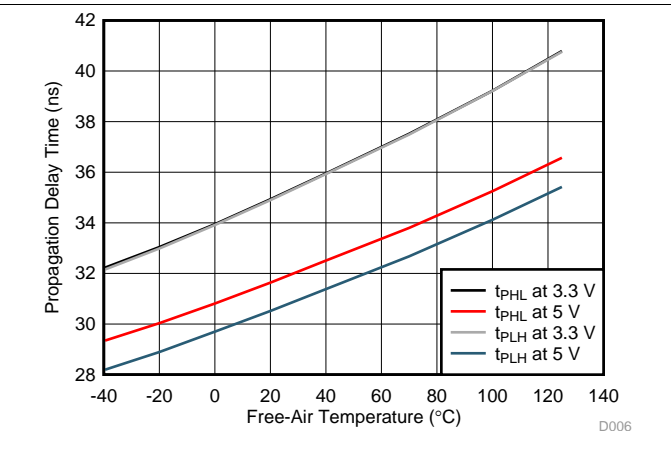

Figure 11. Propagation Delay Time vs Free-Air Temperature

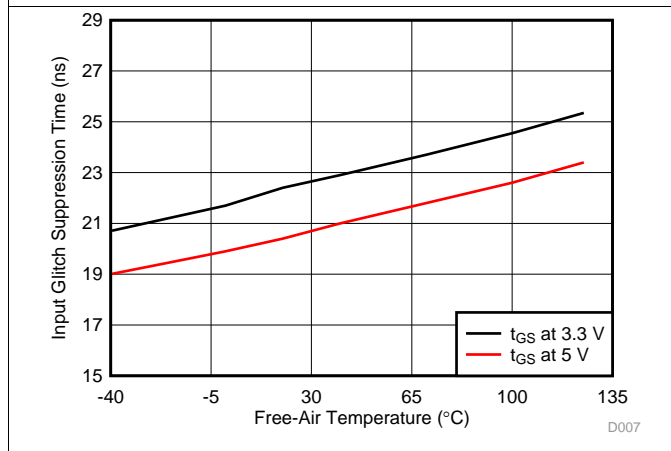

Figure 12. Input Glitch Suppression Time vs Free-Air Temperature

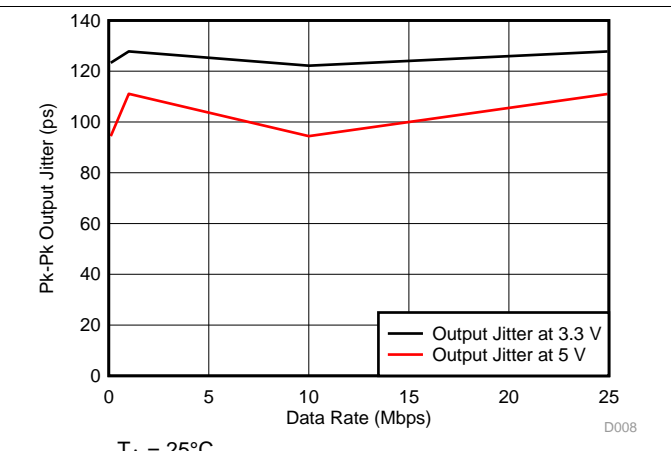
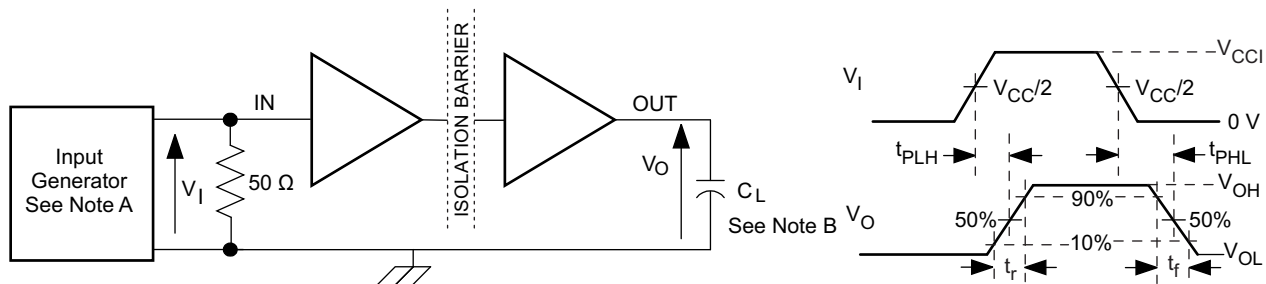

Figure 13. Output Jitter vs Data Rate

8 Parameter Measurement Information



- The input pulse is supplied by a generator having the following characteristics: PRR \leq 50 kHz, 50% duty cycle, $t_r \leq$ 3 ns, $t_f \leq$ 3 ns, $Z_O = 50 \Omega$. At the input, 50Ω resistor is required to terminate Input Generator signal. It is not needed in actual application.
- $C_L = 15$ pF and includes instrumentation and fixture capacitance within $\pm 20\%$.

Figure 14. Switching Characteristics Test Circuit and Voltage Waveforms

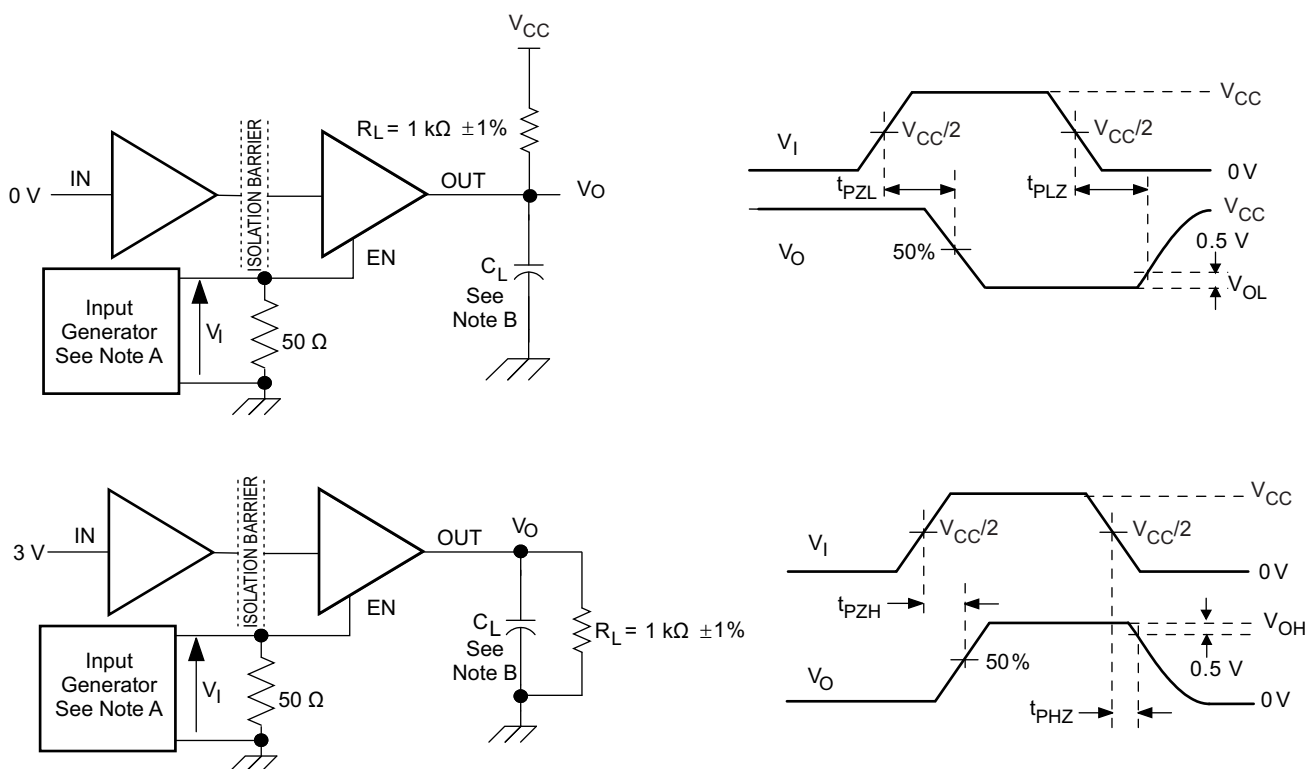

- The input pulse is supplied by a generator having the following characteristics: PRR \leq 10 kHz, 50% duty cycle, $t_r \leq$ 3 ns, $t_f \leq$ 3 ns, $Z_O = 50 \Omega$.
- $C_L = 15$ pF and includes instrumentation and fixture capacitance within $\pm 20\%$.

Figure 15. Enable/Disable Propagation Delay Time Test Circuit and Waveform

Parameter Measurement Information (continued)

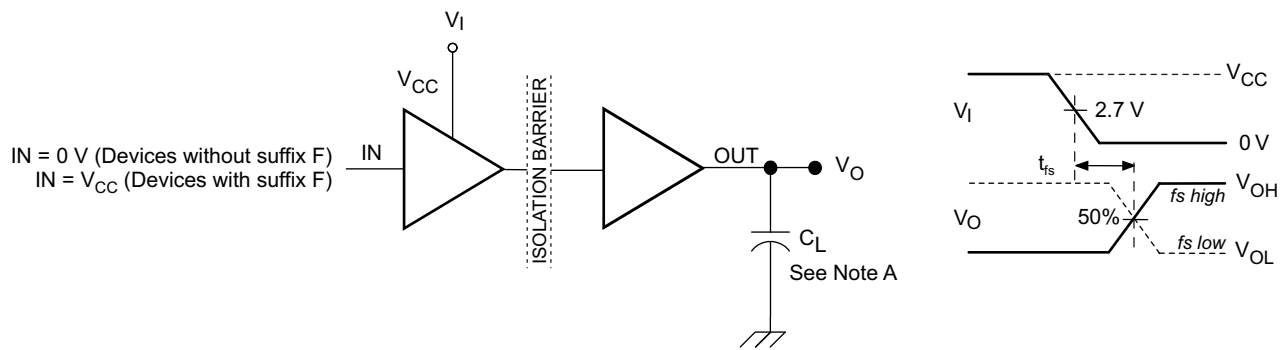

A. $C_L = 15 \text{ pF}$ and includes instrumentation and fixture capacitance within $\pm 20\%$.

Figure 16. Failsafe Delay Time Test Circuit and Voltage Waveforms

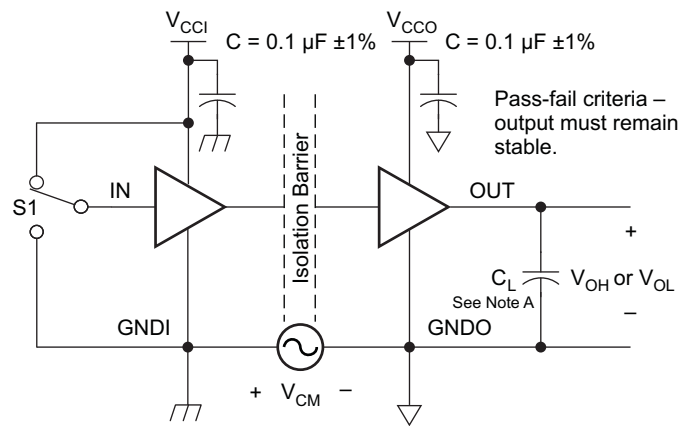

A. $C_L = 15 \text{ pF}$ and includes instrumentation and fixture capacitance within $\pm 20\%$.

Figure 17. Common-Mode Transient Immunity Test Circuit

9 Detailed Description

9.1 Overview

The isolator in Figure 18 is based on a capacitive isolation-barrier technique. The I/O channel of the device consists of two internal data channels, a high-frequency (HF) channel with a bandwidth from 100 kbps up to 25 Mbps, and a low-frequency (LF) channel covering the range from 100 kbps down to DC.

In principle, a single-ended input signal entering the HF channel is split into a differential signal through the inverter gate at the input. The following capacitor-resistor networks differentiate the signal into transient pulses, which then are converted into CMOS levels by a comparator. The transient pulses at the input of the comparator can be either above or below the common-mode voltage V_{REF} depending on whether the input bit transitioned from 0 to 1 or 1 to 0. The comparator threshold is adjusted based on the expected bit transition. A decision logic (DCL) at the output of the HF channel comparator measures the durations between signal transients. If the duration between two consecutive transients exceeds a certain time limit, (as in the case of a low-frequency signal), the DCL forces the output-multiplexer to switch from the high-frequency to the low-frequency channel.

Because low-frequency input signals require the internal capacitors to assume prohibitively large values, these signals are pulse-width modulated (PWM) with the carrier frequency of an internal oscillator, thus creating a sufficiently high frequency, capable of passing the capacitive barrier. As the input is modulated, a low-pass filter (LPF) is needed to remove the high-frequency carrier from the actual data before passing it on to the output multiplexer.

9.2 Functional Block Diagram

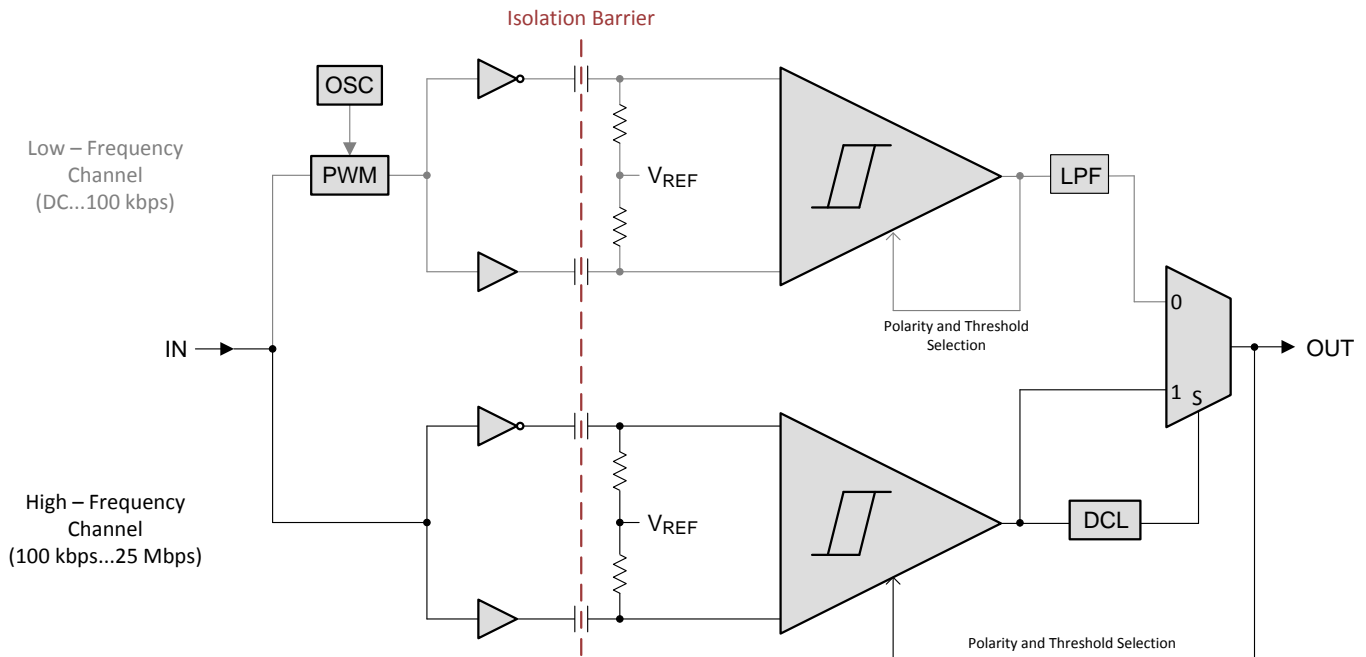

Figure 18. Conceptual Block Diagram of a Digital Capacitive Isolator

9.3 Feature Description

The ISO734x family of devices are available in multiple channel configurations and default output state options to enable wide variety of application uses.

PART NUMBER	CHANNEL DIRECTION	RATED ISOLATION	MAXIMUM DATA RATE	DEFAULT OUTPUT
ISO7340C	4 Forward, 0 Reverse	3000 V _{RMS} / 4242 V _{PK} ⁽¹⁾	25 Mbps	High
ISO7340FC				Low
ISO7341C	3 Forward, 1 Reverse			High
ISO7341FC				Low
ISO7342C	2 Forward, 2 Reverse			High
ISO7342FC				Low

(1) See the [Safety-Related Certifications](#) section for detailed isolation ratings.

9.3.1 Electromagnetic Compatibility (EMC) Considerations

Many applications in harsh industrial environment are sensitive to disturbances such as electrostatic discharge (ESD), electrical fast transient (EFT), surge, and electromagnetic emissions. These electromagnetic disturbances are regulated by international standards such as IEC 61000-4-x and CISPR 22. Although system-level performance and reliability depends, to a large extent, on the application board design and layout, the ISO734x family of devices incorporates many chip-level design improvements for overall system robustness. Some of these improvements include:

- Robust ESD protection cells for input and output signal pins and inter-chip bond pads.
- Low-resistance connectivity of ESD cells to supply and ground pins.
- Enhanced performance of high voltage isolation capacitor for better tolerance of ESD, EFT and surge events.
- Bigger on-chip decoupling capacitors to bypass undesirable high energy signals through a low impedance path.
- PMOS and NMOS devices isolated from each other by using guard rings to avoid triggering of parasitic SCRs.
- Reduced common mode currents across the isolation barrier by ensuring purely differential internal operation.

9.4 Device Functional Modes

Table 1 lists the functional modes for the ISO734x family of devices.

Table 1. Function Table⁽¹⁾

V _{CCI}	V _{CCO}	INPUT (IN _x)	OUTPUT ENABLE (EN _x)	OUTPUT (OUT _x)	
				ISO734xC	ISO734xFC
PU	PU	H	H or Open	H	H
		L	H or Open	L	L
		X	L	Z	Z
		Open	H or Open	H ⁽²⁾	L ⁽³⁾
PD	PU	X	H or Open	H ⁽²⁾	L ⁽³⁾
X	PU	X	L	Z	Z
X	PD	X	X	Undetermined	Undetermined

- (1) V_{CCI} = Input-side V_{CC}; V_{CCO} = Output-side V_{CC}; PU = Powered up (V_{CC} ≥ 3 V); PD = Powered down (V_{CC} ≤ 2.1 V); X = Irrelevant; H = High level; L = Low level; Z = High Impedance
- (2) In fail-safe condition, output defaults to high level
- (3) In fail-safe condition, output defaults to low level

9.4.1 Device I/O Schematics

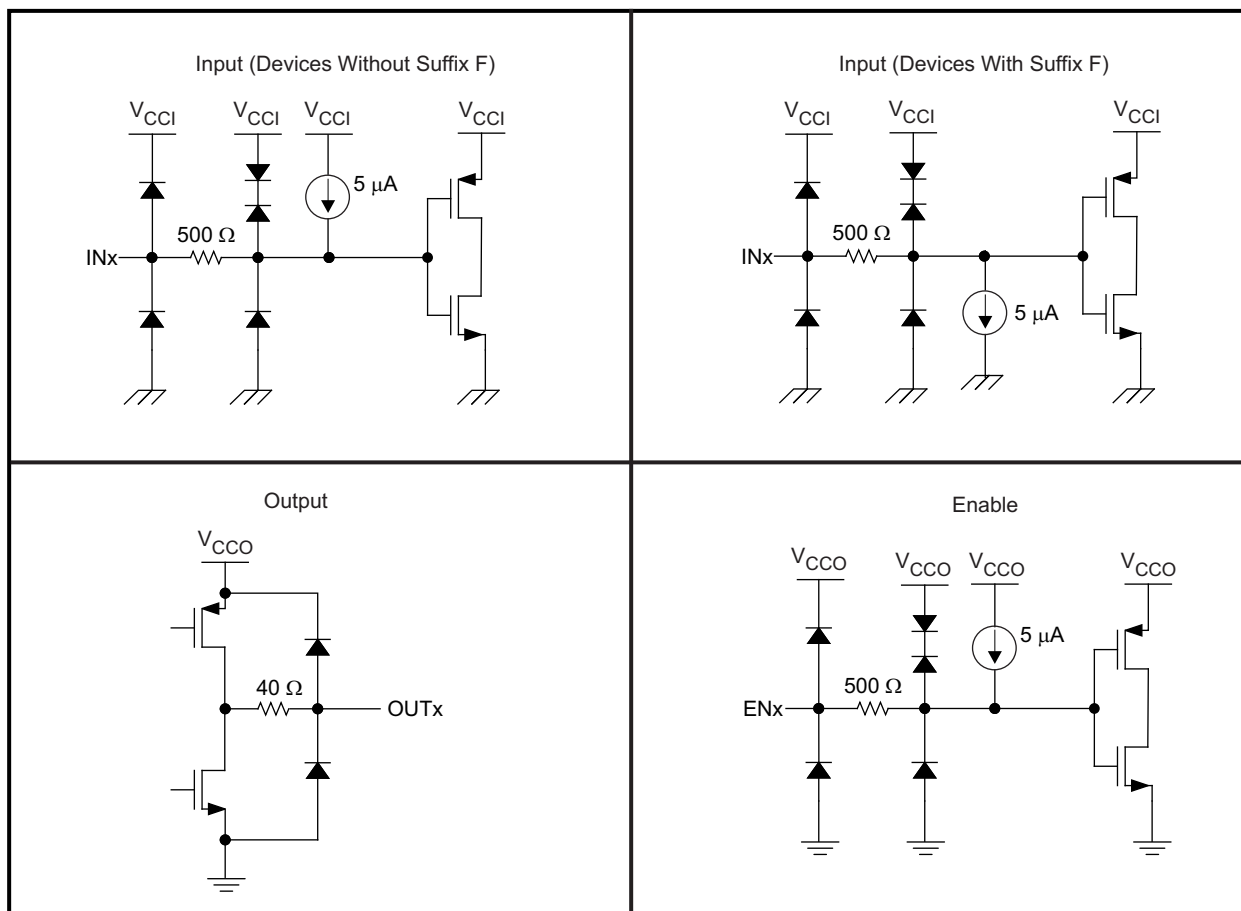

Figure 19. Device I/O Schematics

10 Application and Implementation

NOTE

Information in the following applications sections is not part of the TI component specification, and TI does not warrant its accuracy or completeness. TI's customers are responsible for determining suitability of components for their purposes. Customers should validate and test their design implementation to confirm system functionality.

10.1 Application Information

The ISO734x family of devices use single-ended TTL-logic switching technology. The supply voltage range is from 3 V to 5.5 V for both supplies, V_{CC1} and V_{CC2} . When designing with digital isolators, keep in mind that because of the single-ended design structure, digital isolators do not conform to any specific interface standard and are only intended for isolating single-ended CMOS or TTL digital signal lines. The isolator is typically placed between the data controller (that is, μ C or UART), and a data converter or a line transceiver, regardless of the interface type or standard.

10.2 Typical Application

10.2.1 Isolated Data Acquisition System for Process Control

The ISO734x family of devices combined with Texas Instruments' precision analog-to-digital converter and mixed signal micro-controller can create an advanced isolated data acquisition system as shown in [Figure 20](#).

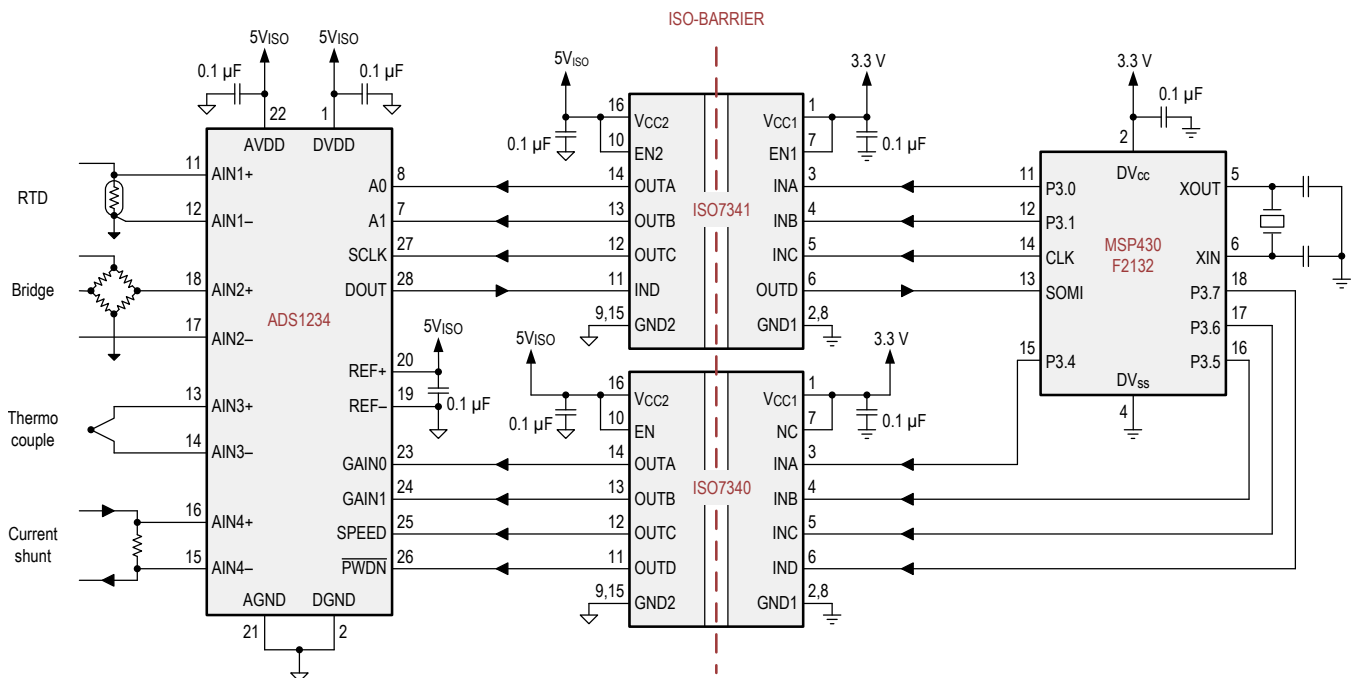

Figure 20. Isolated Data-Acquisition System for Process Control

Typical Application (continued)

10.2.1.1 Design Requirements

Unlike optocouplers, which require external components to improve performance, provide bias, or limit current, the ISO734x family of devices only requires two external bypass capacitors to operate.

10.2.1.2 Detailed Design Procedure

10.2.1.2.1 Typical Supply Current Equations

For the equations in this section, the following is true:

- I_{CC1} and I_{CC2} are typical supply currents measured in mA
- f is data rate measured in Mbps
- C_L is the capacitive load measured in pF

10.2.1.2.1.1 ISO7340x

At $V_{CC1} = V_{CC2} = 5\text{ V}$:

$$I_{CC1} = 0.54366 + (0.0873 \times f) \tag{1}$$

$$I_{CC2} = 2.74567 + (0.08433 \times f) + (0.01 \times f \times C_L) \tag{2}$$

At $V_{CC1} = V_{CC2} = 3.3\text{ V}$:

$$I_{CC1} = 0.3437 + (0.04922 \times f) \tag{3}$$

$$I_{CC2} = 2.1068 + (0.04374 \times f) + (0.007045 \times f \times C_L) \tag{4}$$

10.2.1.2.1.2 ISO7341x

At $V_{CC1} = V_{CC2} = 5\text{ V}$:

$$I_{CC1} = 1.7403 + (0.1006 \times f) + (0.001711 \times f \times C_L) \tag{5}$$

$$I_{CC2} = 2.502 + (0.09629 \times f) + (0.00687 \times f \times C_L) \tag{6}$$

At $V_{CC1} = V_{CC2} = 3.3\text{ V}$:

$$I_{CC1} = 1.2915 + (0.046 \times f) + (0.00185 \times f \times C_L) \tag{7}$$

$$I_{CC2} = 1.8833 + (0.0566 \times f) + (0.004514 \times f \times C_L) \tag{8}$$

10.2.1.2.1.3 ISO7342x

At $V_{CC1} = V_{CC2} = 5\text{ V}$:

$$I_{CC1}, I_{CC2} = 2.1254 + (0.08694 \times f) + (0.004868 \times f \times C_L) \tag{9}$$

At $V_{CC1} = V_{CC2} = 3.3\text{ V}$:

$$I_{CC1}, I_{CC2} = 1.5912 + (0.0410 \times f) + (0.003785 \times f \times C_L) \tag{10}$$

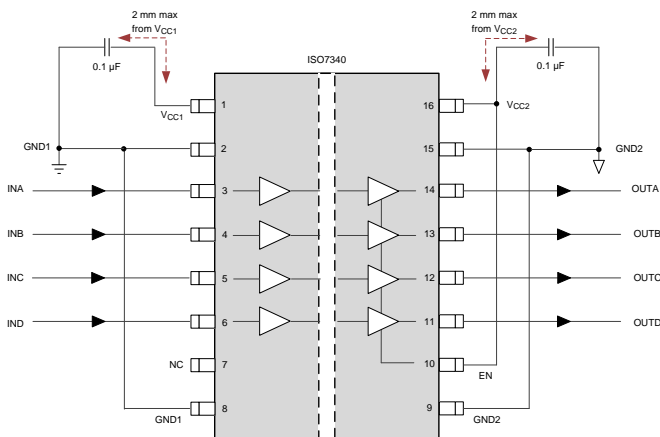

Figure 21. Typical ISO7340x Circuit Hook-up

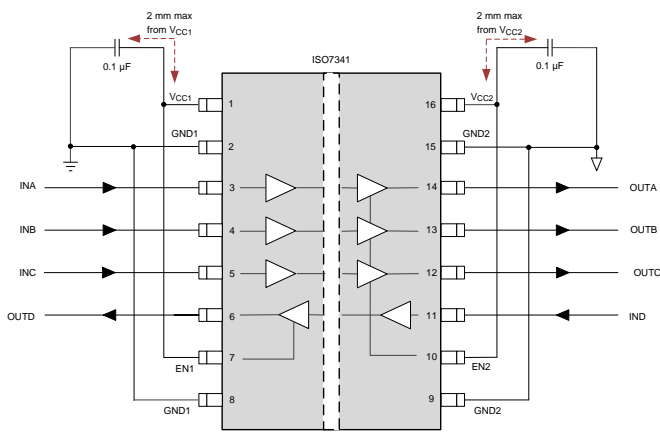

Figure 22. Typical ISO7341x Circuit Hook-up

Typical Application (continued)

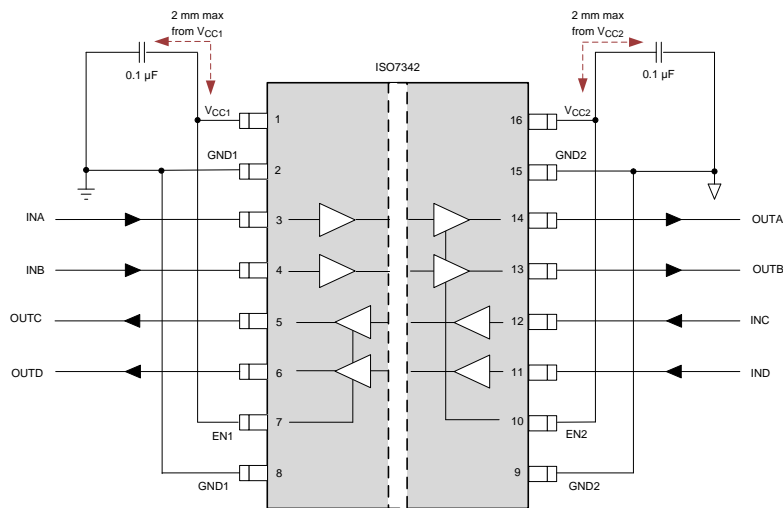

Figure 23. Typical ISO7342x Circuit Hook-up

10.2.1.3 Application Curves

The typical eye diagrams of the ISO734x family of devices indicate low jitter and a wide open eye at the maximum data rate of 25 Mbps.

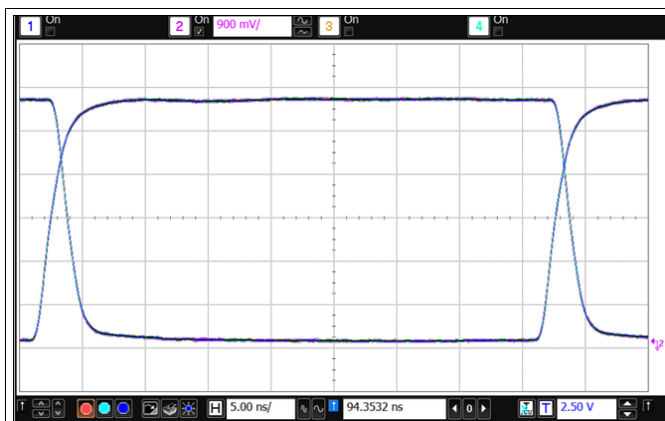

Figure 24. Eye Diagram at 25 Mbps, 5 V and 25°C

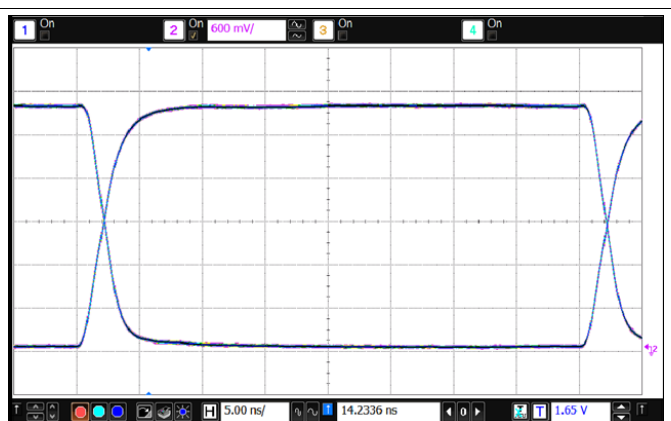

Figure 25. Eye Diagram at 25 Mbps, 3.3 V and 25°C

Typical Application (continued)

10.2.2 Typical Application for Module With 16 Inputs

The ISO7341x device and several other components from Texas Instruments can be used to create an isolated serial peripheral interface (SPI) for input module with 16 inputs.

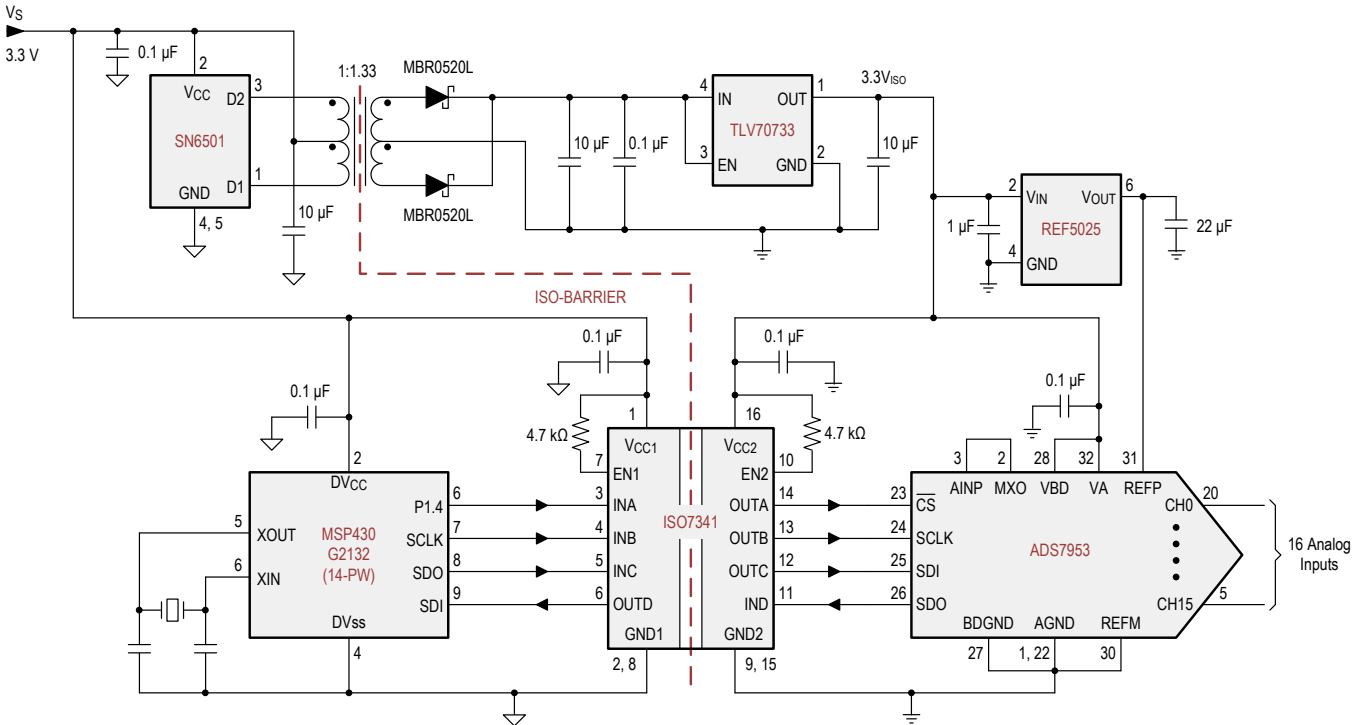

Figure 26. Isolated SPI for an Analog Input Module With 16 Inputs

10.2.2.1 Design Requirements

Refer to [Isolated Data Acquisition System for Process Control](#) for the design requirements.

10.2.2.2 Detailed Design Procedure

Refer to [Isolated Data Acquisition System for Process Control](#) for the detailed design procedures.

10.2.2.3 Application Curves

Refer to [Isolated Data Acquisition System for Process Control](#) for the application curves.

Typical Application (continued)

10.2.3 Typical Application for RS-232 Interface

Typical isolated RS-232 interface implementation is shown in [Figure 27](#).

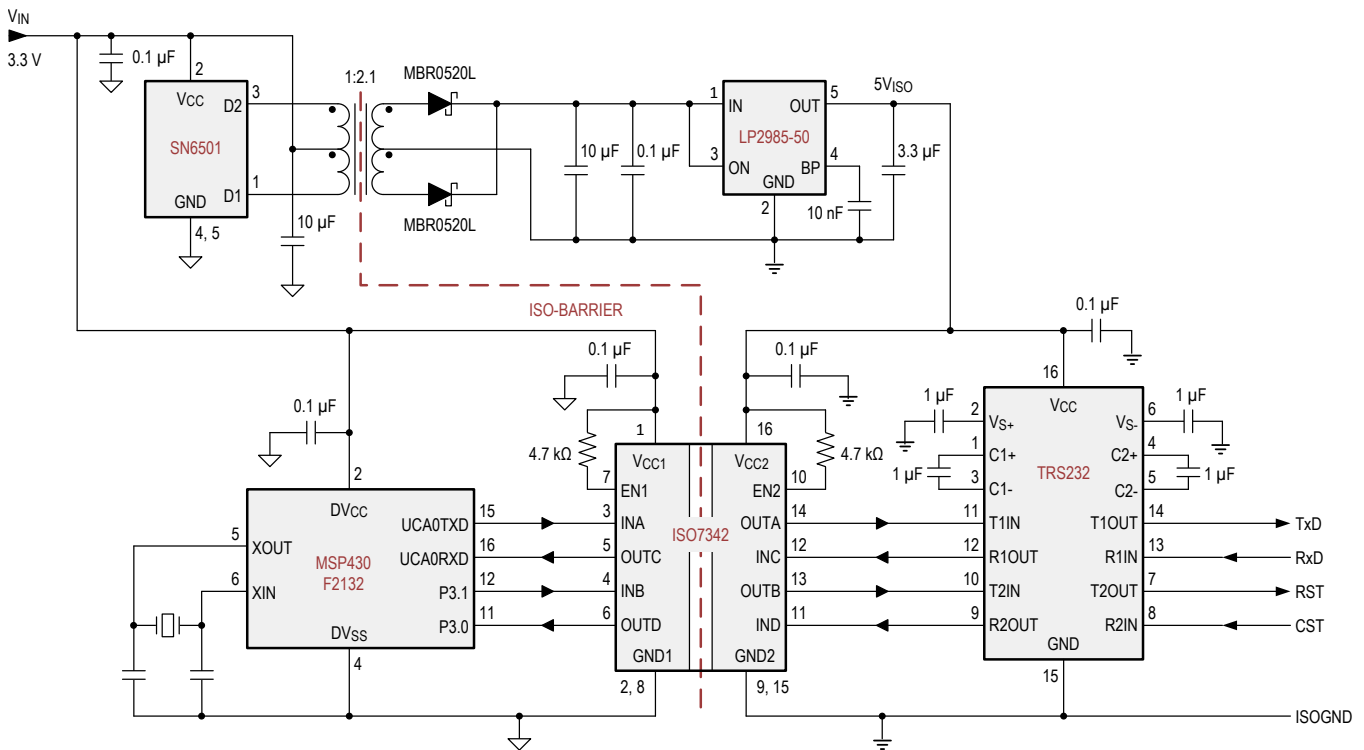

Figure 27. Isolated RS-232 Interface

10.2.3.1 Design Requirements

Refer to [Isolated Data Acquisition System for Process Control](#) for the design requirements.

10.2.3.2 Detailed Design Procedure

Refer to [Isolated Data Acquisition System for Process Control](#) for the detailed design procedures.

10.2.3.3 Application Curves

Refer to [Isolated Data Acquisition System for Process Control](#) for the application curves.

11 Power Supply Recommendations

To help ensure reliable operation at data rates and supply voltages, a 0.1-µF bypass capacitor is recommended at input and output supply pins (V_{CC1} and V_{CC2}). The capacitors should be placed as close to the supply pins as possible. If only a single primary-side power supply is available in an application, isolated power can be generated for the secondary-side with the help of a transformer driver such as Texas Instruments' [SN6501](#). For such applications, detailed power supply design and transformer selection recommendations are available in [SN6501 Transformer Driver for Isolated Power Supplies](#).

12 Layout

12.1 Layout Guidelines

A minimum of four layers is required to accomplish a low EMI PCB design (see [Figure 28](#)). Layer stacking should be in the following order (top-to-bottom): high-speed signal layer, ground plane, power plane and low-frequency signal layer.

- Routing the high-speed traces on the top layer avoids the use of vias (and the introduction of their inductances) and allows for clean interconnects between the isolator and the transmitter and receiver circuits of the data link.
- Placing a solid ground plane next to the high-speed signal layer establishes controlled impedance for transmission line interconnects and provides an excellent low-inductance path for the return current flow.
- Placing the power plane next to the ground plane creates additional high-frequency bypass capacitance of approximately 100 pF/in².
- Routing the slower speed control signals on the bottom layer allows for greater flexibility as these signal links usually have margin to tolerate discontinuities such as vias.

If an additional supply voltage plane or signal layer is needed, add a second power or ground plane system to the stack to keep it symmetrical. This makes the stack mechanically stable and prevents it from warping. Also the power and ground plane of each power system can be placed closer together, thus increasing the high-frequency bypass capacitance significantly.

For detailed layout recommendations, see the [Digital Isolator Design Guide](#).

12.1.1 PCB Material

For digital circuit boards operating at less than 150 Mbps, (or rise and fall times greater than 1 ns), and trace lengths of up to 10 inches, use standard FR-4 UL94V-0 printed circuit board. This PCB is preferred over cheaper alternatives because of lower dielectric losses at high frequencies, less moisture absorption, greater strength and stiffness, and the self-extinguishing flammability-characteristics.

12.2 Layout Example

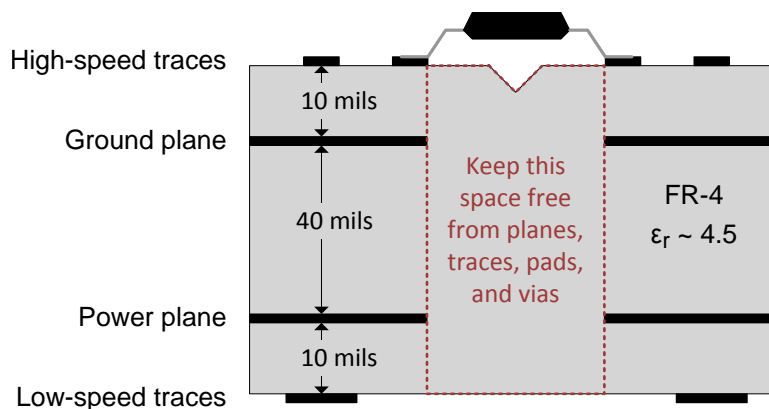

Figure 28. Recommended Layer Stack

13 Device and Documentation Support

13.1 Documentation Support

13.1.1 Related Documentation

For related documentation see the following:

- [Isolation Glossary](#)
- [Digital Isolator Design Guide](#)
- [SN6501-Q1 Transformer Driver for Isolated Power Supplies](#)

13.2 Related Links

The table below lists quick access links. Categories include technical documents, support and community resources, tools and software, and quick access to sample or buy.

Table 2. Related Links

PARTS	PRODUCT FOLDER	ORDER NOW	TECHNICAL DOCUMENTS	TOOLS & SOFTWARE	SUPPORT & COMMUNITY
ISO7340C	Click here	Click here	Click here	Click here	Click here
ISO7340FC	Click here	Click here	Click here	Click here	Click here
ISO7341C	Click here	Click here	Click here	Click here	Click here
ISO7341FC	Click here	Click here	Click here	Click here	Click here
ISO7342C	Click here	Click here	Click here	Click here	Click here
ISO7342FC	Click here	Click here	Click here	Click here	Click here

13.3 Receiving Notification of Documentation Updates

To receive notification of documentation updates, navigate to the device product folder on ti.com. In the upper right corner, click on *Alert me* to register and receive a weekly digest of any product information that has changed. For change details, review the revision history included in any revised document.

13.4 Community Resource

The following links connect to TI community resources. Linked contents are provided "AS IS" by the respective contributors. They do not constitute TI specifications and do not necessarily reflect TI's views; see TI's [Terms of Use](#).

TI E2E™ Online Community *TI's Engineer-to-Engineer (E2E) Community*. Created to foster collaboration among engineers. At e2e.ti.com, you can ask questions, share knowledge, explore ideas and help solve problems with fellow engineers.

Design Support *TI's Design Support* Quickly find helpful E2E forums along with design support tools and contact information for technical support.

13.5 Trademarks

E2E is a trademark of Texas Instruments.
All other trademarks are the property of their respective owners.

13.6 Electrostatic Discharge Caution



These devices have limited built-in ESD protection. The leads should be shorted together or the device placed in conductive foam during storage or handling to prevent electrostatic damage to the MOS gates.

13.7 Glossary

SLYZ022 — *TI Glossary*.

This glossary lists and explains terms, acronyms, and definitions.

14 Mechanical, Packaging, and Orderable Information

The following pages include mechanical packaging and orderable information. This information is the most current data available for the designated devices. This data is subject to change without notice and revision of this document. For browser-based versions of this data sheet, refer to the left-hand navigation.

DW0016B
PACKAGE OUTLINE
SOIC - 2.65 mm max height

SOIC

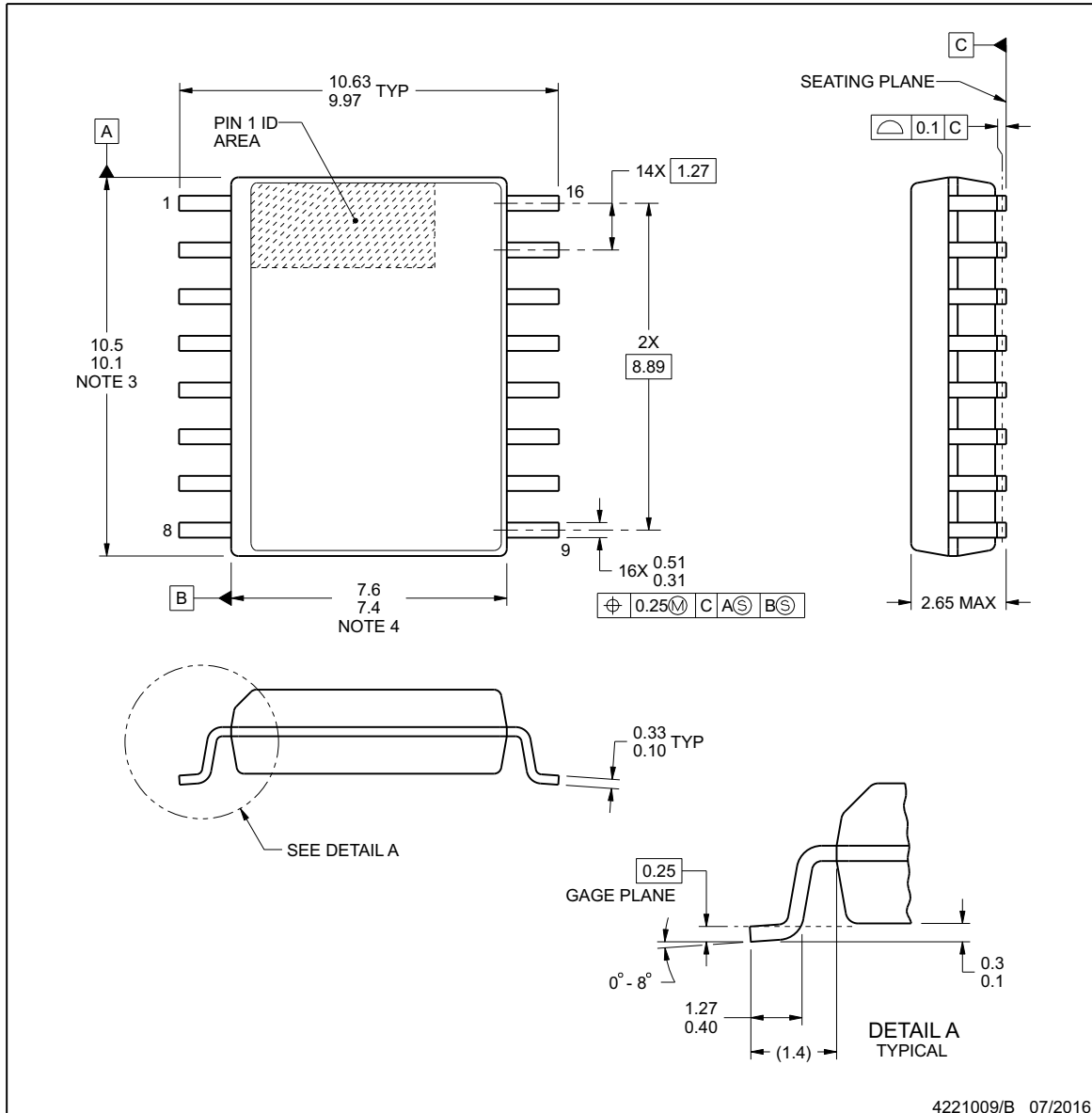
NOTES:

1. All linear dimensions are in millimeters. Dimensions in parenthesis are for reference only. Dimensioning and tolerancing per ASME Y14.5M.
2. This drawing is subject to change without notice.
3. This dimension does not include mold flash, protrusions, or gate burrs. Mold flash, protrusions, or gate burrs shall not exceed 0.15 mm, per side.
4. This dimension does not include interlead flash. Interlead flash shall not exceed 0.25 mm, per side.
5. Reference JEDEC registration MS-013.

EXAMPLE BOARD LAYOUT

DW0016B

SOIC - 2.65 mm max height

SOIC

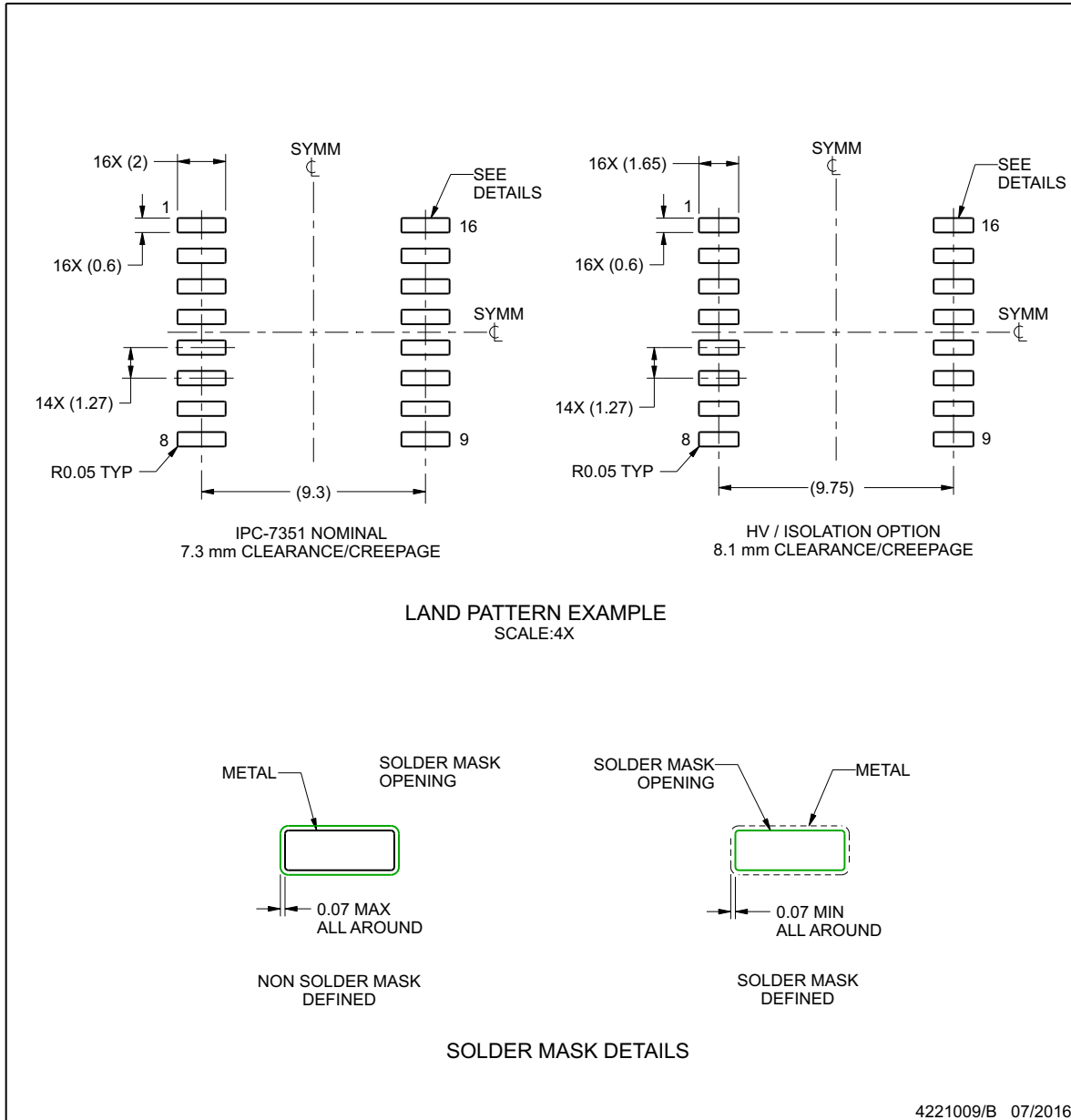

NOTES: (continued)

- 6. Publication IPC-7351 may have alternate designs.
- 7. Solder mask tolerances between and around signal pads can vary based on board fabrication site.

EXAMPLE STENCIL DESIGN

DW0016B
SOIC - 2.65 mm max height

SOIC

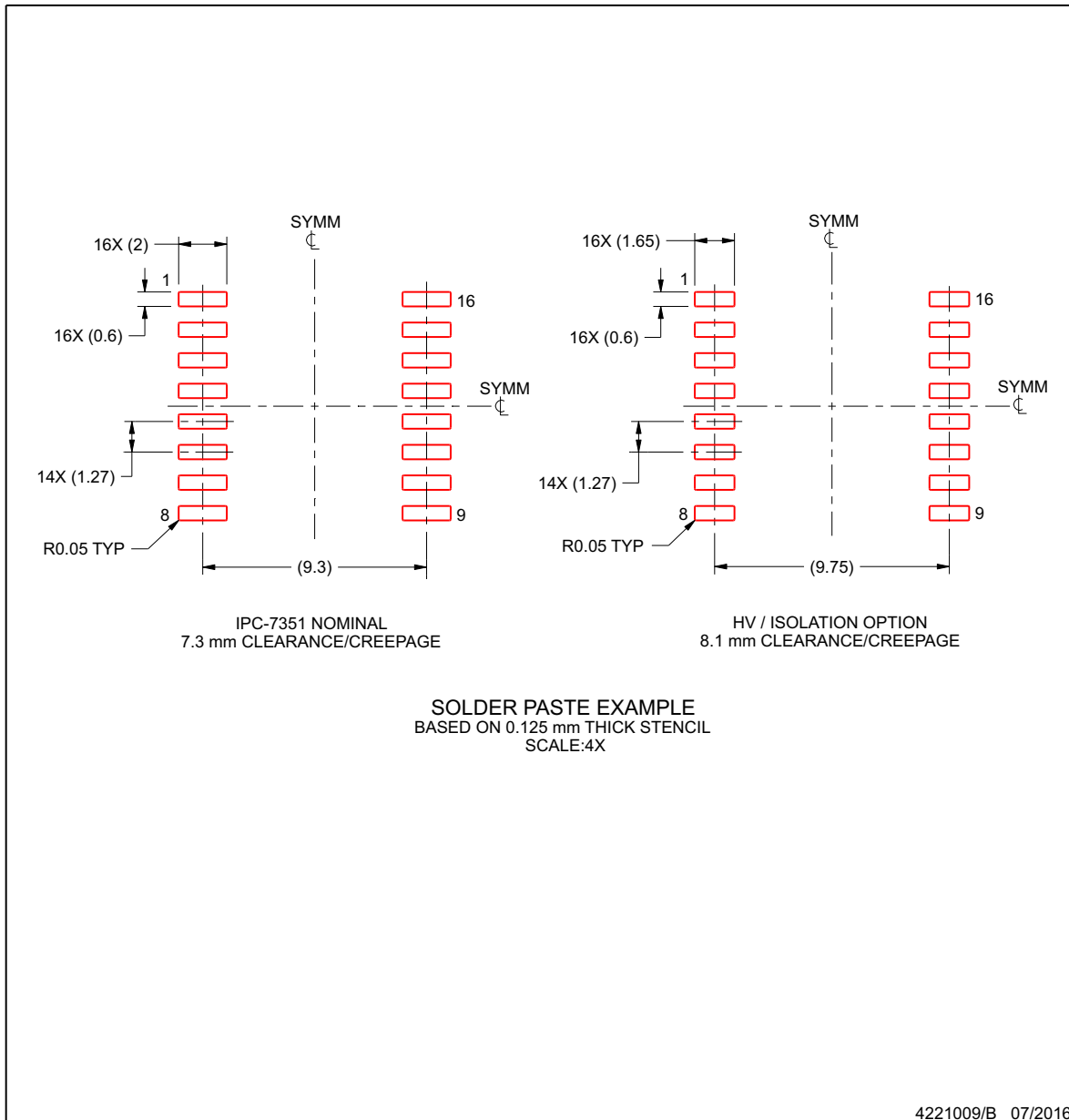

NOTES: (continued)

8. Laser cutting apertures with trapezoidal walls and rounded corners may offer better paste release. IPC-7525 may have alternate design recommendations.
9. Board assembly site may have different recommendations for stencil design.

PACKAGING INFORMATION

Orderable Device	Status (1)	Package Type	Package Drawing	Pins	Package Qty	Eco Plan (2)	Lead/Ball Finish (6)	MSL Peak Temp (3)	Op Temp (°C)	Device Marking (4/5)	Samples
ISO7340CDW	ACTIVE	SOIC	DW	16	40	Green (RoHS & no Sb/Br)	CU NIPDAU	Level-2-260C-1 YEAR	-40 to 125	ISO7340C	Samples
ISO7340CDWR	ACTIVE	SOIC	DW	16	2000	Green (RoHS & no Sb/Br)	CU NIPDAU	Level-2-260C-1 YEAR	-40 to 125	ISO7340C	Samples
ISO7340FCDW	ACTIVE	SOIC	DW	16	40	Green (RoHS & no Sb/Br)	CU NIPDAU	Level-2-260C-1 YEAR	-40 to 125	ISO7340FC	Samples
ISO7340FCDWR	ACTIVE	SOIC	DW	16	2000	Green (RoHS & no Sb/Br)	CU NIPDAU	Level-2-260C-1 YEAR	-40 to 125	ISO7340FC	Samples
ISO7341CDW	ACTIVE	SOIC	DW	16	40	Green (RoHS & no Sb/Br)	CU NIPDAU	Level-2-260C-1 YEAR	-40 to 125	ISO7341C	Samples
ISO7341CDWR	ACTIVE	SOIC	DW	16	2000	Green (RoHS & no Sb/Br)	CU NIPDAU	Level-2-260C-1 YEAR	-40 to 125	ISO7341C	Samples
ISO7341FCDW	ACTIVE	SOIC	DW	16	40	Green (RoHS & no Sb/Br)	CU NIPDAU	Level-2-260C-1 YEAR	-40 to 125	ISO7341FC	Samples
ISO7341FCDWR	ACTIVE	SOIC	DW	16	2000	Green (RoHS & no Sb/Br)	CU NIPDAU	Level-2-260C-1 YEAR	-40 to 125	ISO7341FC	Samples
ISO7342CDW	ACTIVE	SOIC	DW	16	40	Green (RoHS & no Sb/Br)	CU NIPDAU	Level-2-260C-1 YEAR	-40 to 125	ISO7342C	Samples
ISO7342CDWR	ACTIVE	SOIC	DW	16	2000	Green (RoHS & no Sb/Br)	CU NIPDAU	Level-2-260C-1 YEAR	-40 to 125	ISO7342C	Samples
ISO7342FCDW	ACTIVE	SOIC	DW	16	40	Green (RoHS & no Sb/Br)	CU NIPDAU	Level-2-260C-1 YEAR	-40 to 125	ISO7342FC	Samples
ISO7342FCDWR	ACTIVE	SOIC	DW	16	2000	Green (RoHS & no Sb/Br)	CU NIPDAU	Level-2-260C-1 YEAR	-40 to 125	ISO7342FC	Samples

(1) The marketing status values are defined as follows:

ACTIVE: Product device recommended for new designs.

LIFEBUY: TI has announced that the device will be discontinued, and a lifetime-buy period is in effect.

NRND: Not recommended for new designs. Device is in production to support existing customers, but TI does not recommend using this part in a new design.

PREVIEW: Device has been announced but is not in production. Samples may or may not be available.

OBSELETE: TI has discontinued the production of the device.

(2) Eco Plan - The planned eco-friendly classification: Pb-Free (RoHS), Pb-Free (RoHS Exempt), or Green (RoHS & no Sb/Br) - please check <http://www.ti.com/productcontent> for the latest availability information and additional product content details.

TBD: The Pb-Free/Green conversion plan has not been defined.

Pb-Free (RoHS): TI's terms "Lead-Free" or "Pb-Free" mean semiconductor products that are compatible with the current RoHS requirements for all 6 substances, including the requirement that lead not exceed 0.1% by weight in homogeneous materials. Where designed to be soldered at high temperatures, TI Pb-Free products are suitable for use in specified lead-free processes.

Pb-Free (RoHS Exempt): This component has a RoHS exemption for either 1) lead-based flip-chip solder bumps used between the die and package, or 2) lead-based die adhesive used between the die and leadframe. The component is otherwise considered Pb-Free (RoHS compatible) as defined above.

Green (RoHS & no Sb/Br): TI defines "Green" to mean Pb-Free (RoHS compatible), and free of Bromine (Br) and Antimony (Sb) based flame retardants (Br or Sb do not exceed 0.1% by weight in homogeneous material)

⁽³⁾ MSL, Peak Temp. - The Moisture Sensitivity Level rating according to the JEDEC industry standard classifications, and peak solder temperature.

⁽⁴⁾ There may be additional marking, which relates to the logo, the lot trace code information, or the environmental category on the device.

⁽⁵⁾ Multiple Device Markings will be inside parentheses. Only one Device Marking contained in parentheses and separated by a "~" will appear on a device. If a line is indented then it is a continuation of the previous line and the two combined represent the entire Device Marking for that device.

⁽⁶⁾ Lead/Ball Finish - Orderable Devices may have multiple material finish options. Finish options are separated by a vertical ruled line. Lead/Ball Finish values may wrap to two lines if the finish value exceeds the maximum column width.

Important Information and Disclaimer:The information provided on this page represents TI's knowledge and belief as of the date that it is provided. TI bases its knowledge and belief on information provided by third parties, and makes no representation or warranty as to the accuracy of such information. Efforts are underway to better integrate information from third parties. TI has taken and continues to take reasonable steps to provide representative and accurate information but may not have conducted destructive testing or chemical analysis on incoming materials and chemicals. TI and TI suppliers consider certain information to be proprietary, and thus CAS numbers and other limited information may not be available for release.

In no event shall TI's liability arising out of such information exceed the total purchase price of the TI part(s) at issue in this document sold by TI to Customer on an annual basis.

TAPE AND REEL INFORMATION

QUADRANT ASSIGNMENTS FOR PIN 1 ORIENTATION IN TAPE

*All dimensions are nominal

Device	Package Type	Package Drawing	Pins	SPQ	Reel Diameter (mm)	Reel Width W1 (mm)	A0 (mm)	B0 (mm)	K0 (mm)	P1 (mm)	W (mm)	Pin1 Quadrant
ISO7340CDWR	SOIC	DW	16	2000	330.0	16.4	10.75	10.7	2.7	12.0	16.0	Q1
ISO7340FCDWR	SOIC	DW	16	2000	330.0	16.4	10.75	10.7	2.7	12.0	16.0	Q1
ISO7341CDWR	SOIC	DW	16	2000	330.0	16.4	10.75	10.7	2.7	12.0	16.0	Q1
ISO7341FCDWR	SOIC	DW	16	2000	330.0	16.4	10.75	10.7	2.7	12.0	16.0	Q1
ISO7342CDWR	SOIC	DW	16	2000	330.0	16.4	10.75	10.7	2.7	12.0	16.0	Q1
ISO7342FCDWR	SOIC	DW	16	2000	330.0	16.4	10.75	10.7	2.7	12.0	16.0	Q1

TAPE AND REEL BOX DIMENSIONS

*All dimensions are nominal

Device	Package Type	Package Drawing	Pins	SPQ	Length (mm)	Width (mm)	Height (mm)
ISO7340CDWR	SOIC	DW	16	2000	350.0	350.0	43.0
ISO7340FCDWR	SOIC	DW	16	2000	350.0	350.0	43.0
ISO7341CDWR	SOIC	DW	16	2000	350.0	350.0	43.0
ISO7341FCDWR	SOIC	DW	16	2000	350.0	350.0	43.0
ISO7342CDWR	SOIC	DW	16	2000	350.0	350.0	43.0
ISO7342FCDWR	SOIC	DW	16	2000	350.0	350.0	43.0

IMPORTANT NOTICE AND DISCLAIMER

TI PROVIDES TECHNICAL AND RELIABILITY DATA (INCLUDING DATASHEETS), DESIGN RESOURCES (INCLUDING REFERENCE DESIGNS), APPLICATION OR OTHER DESIGN ADVICE, WEB TOOLS, SAFETY INFORMATION, AND OTHER RESOURCES "AS IS" AND WITH ALL FAULTS, AND DISCLAIMS ALL WARRANTIES, EXPRESS AND IMPLIED, INCLUDING WITHOUT LIMITATION ANY IMPLIED WARRANTIES OF MERCHANTABILITY, FITNESS FOR A PARTICULAR PURPOSE OR NON-INFRINGEMENT OF THIRD PARTY INTELLECTUAL PROPERTY RIGHTS.

These resources are intended for skilled developers designing with TI products. You are solely responsible for (1) selecting the appropriate TI products for your application, (2) designing, validating and testing your application, and (3) ensuring your application meets applicable standards, and any other safety, security, or other requirements. These resources are subject to change without notice. TI grants you permission to use these resources only for development of an application that uses the TI products described in the resource. Other reproduction and display of these resources is prohibited. No license is granted to any other TI intellectual property right or to any third party intellectual property right. TI disclaims responsibility for, and you will fully indemnify TI and its representatives against, any claims, damages, costs, losses, and liabilities arising out of your use of these resources.

TI's products are provided subject to TI's Terms of Sale (www.ti.com/legal/termsofsale.html) or other applicable terms available either on ti.com or provided in conjunction with such TI products. TI's provision of these resources does not expand or otherwise alter TI's applicable warranties or warranty disclaimers for TI products.

Mailing Address: Texas Instruments, Post Office Box 655303, Dallas, Texas 75265
Copyright © 2019, Texas Instruments Incorporated

Looking for pricing, stock, or lifecycle information?

Click below to explore more details on WIN SOURCE:

 [View ISO7341CDWR](#) on WIN SOURCE

 [Texas Instruments](#) Information

Optimize Your Supply Chain with WIN SOURCE Solutions

-  Global Sourcing Solution
-  Obsolete Management
-  Cost Control Management
-  Shortage Management
-  Alternative Solution
-  Excess Inventory Management