



**THE DATASHEET OF
AEDS-9240-G00**



AEDS-9240 Series

360/720 CPR Commutation Encoder Module



Data Sheet

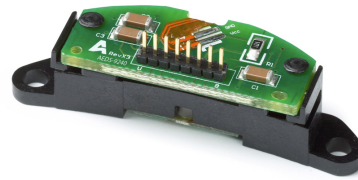

Description

The AEDS-9240 optical encoder is a six channel optical incremental encoder module. When used with a code-wheel, this encoder detects rotary position. Each module consists of a lensed LED source and a detector IC enclosed in a small plastic package. Due to a highly collimated light source and a unique photo detector array, these modules are extremely tolerant to mounting misalignment.

The AEDS-9240 encoder is designed with integrated commutation output channels (U,V,W), two-channel quadrature outputs (A,B), plus a third channel ungated index output (I). This ungated index output is a positive index pulse that is generated once for each full rotation of the codewheel.

The AEDS-9240 encoder is designed for use with a code-wheel that has an optical radius of 19.00 mm (0.748 inch) to obtain an optimum 360/720 CPR (count per revolution) resolution.

The quadrature, index, commutation signals and power supplied to encoder are accessed through eight 0.46mm square male connector pins located on 1.27mm pitch.

The AEDS-9240 optical encoder also provides advanced motion control detection. Its integrated commutation outputs (U,V, and W) is equivalent to those produced by Hall Switches. Thus, this makes the encoder ideal for servo motor applications. Application of the AEDS-9240 encoder also enables motor systems to be more compact. In addition, the provision of alignment jigs enables a significantly reduced production time and ease of assembly into housed encoders. The encoder also provides superior switching accuracy due to a much lower hysteresis when compared to Hall Switches. Its commutation signals can easily be interchanged for Brushless DC motor of different rotor pole-pairs by simply switching to matching pole-pair codewheels.

Features

- Two-channel quadrature output with ungated index pulse (A,B,I)
- Three-channel integrated commutation Output (UVW)
- 360/720 Cycle Per Revolution (CPR)
- Easy assembly with alignment jig
- Design to fit into circular shaped housing
- Up to 150 kHz frequency response
- -40°C to 100°C operating temperature
- TTL Compatible
- Single 5V Supply
- Integrated feedback device for Brushless DC Motor
- RoHS Compliant

Applications

Typical applications include industrial printers, plotters, tape drives, industrial and factory automation equipment.

Note:

Avago Technologies encoders are not recommended for use in safety critical application, e.g., ABS braking systems, power steering, life support systems and critical care medical equipment. Please contact sales representative if more clarification is needed.

Theory of Operation

The AEDS-9240 optical encoder is an emitter/detector module. Coupled with a codewheel, these modules translate the rotary motion of a shaft into a six-channel digital output.

The modules contain a single Light Emitting Diode (LED) as its light source. The light is collimated into a parallel beam by means of a single polycarbonate lens located directly over the LED. Opposite the emitter is the integrated detector circuit. This IC consists of multiple sets of photo detectors and the signal processing circuitry necessary to produce the digital waveforms.

The codewheel rotates between the emitter and detector, causing the light beam to be interrupted by the pattern of spaces and bars on the codewheel.

The photodiodes that detect these interruptions are arranged in a pattern that corresponds to the radius and design of the code-wheel. These detectors are also deliberately spaced such that a light period on one pair of detectors corresponds to a dark period on the adjacent pair of detectors.

The photodiode outputs are then fed through the signal processing circuitry resulting in A, /A, B, /B, I, and /I. Comparators receive these signals and produce the final outputs for channels A and B. Due to this integrated phasing technique, the digital output of channel A is in quadrature with that of channel B (90 mechanical degrees out of phase). The commutation feedback (U, V, W) signals are generated based on the codewheel design.

Definition

Count (N): The number of electrical cycles per revolution (CPR). CPR refers to the raw signal from encoder that is the cycles before 4x decode.

One Cycle: 360 electrical degrees ($^{\circ}$ e).

One Shaft Rotation: 360 mechanical degrees.

Cycle Error (ΔC): An indication of cycle uniformity. The difference between an observed shaft angle which gives rise to one electrical cycle, and the nominal angular increment of $1/N$ of a revolution.

Pulse Width (P): The number of electrical degrees that an output is high during 1 cycle. This value is nominally 180° e or $1/2$ cycle.

Pulse Width Error (ΔP): The deviation, in electrical degrees, of the pulse width from its ideal value of 180° e.

State Width (S): The numbers of electrical degrees between transitions in the output of channel A and the neighboring transition in the output of channel B. There are 4 states per cycle, each nominally 90° e.

State Width Error (ΔS): The deviation, in electrical degrees, of each state width from its ideal value of 90° e.

Commutation Accuracy (ΔI): The deviation, in mechanical degrees, after shaft rotates passes the reference point (Index channel) to the first U channel pulse. The measurement from middle of channel I to channel U.

Phase (Φ): The numbers of electrical degrees between the center of the high state of channel A and the center of the high state of channel B.

This value is nominally 90° e for quadrature output.

Phase Error ($\Delta \Phi$): The deviation of the phase from its ideal value of 90° e.

Direction of Rotation: When the codewheel rotates in the clockwise direction viewing from top of the module, channel A will lead channel B. If the codewheel rotates in the opposite direction, channel B will lead channel A.

Optical Radius (Rop): The distance from the codewheel's center of rotation to the optical center (O.C) of the encoder module.

Index Pulse Width (Po): The number of electrical degrees that an index is high with reference to channel A or channel B during one full shaft rotation

AEDS-9240 Technical Specifications

Absolute Maximum Ratings

Parameter	Symbol	Min.	Max.	Units	Notes
Storage Temperature	T _S	-40	100	°C	
Operating Temperature	T _A	-40	100	°C	
Supply Voltage	V _{CC}	-0.5	7	Volts	

Recommended Operating Conditions

Parameter	Min.	Typ.	Max.	Units	Notes
Temperature	-40	25	100	°C	
Supply Voltage (Detector)	4.5	5.0	5.5	Volts	Ripple < 100mVpp
Operating Frequency					
360 CPR			75	kHz	Velocity (rpm) x N/60
720 CPR			150	kHz	
Shaft Radial Play Plus Eccentricity			0.05	mm TIR	
Shaft Axial Play			±0.100	mm	

Electrical Characteristics

Electrical characteristics over recommend operating range, typical at 25°C

Parameter	Symbol	Min.	Typ.	Max.	Units	Notes
Supply Current	I _{CC}	30	45	60	mA	
High Level Output Voltage	V _{OH}	2.4			V	
Low Level Output Voltage	V _{OL}			0.4	V	
Rise Time	t _r		470		ns	C _L = 50pF
Fall Time	t _f		30		ns	
Loading Capacitance	C _{LOAD}			50	pF	

Encoding Characteristics (Channel A and B)

AEDS-9240-G00 (360 CPR)

Encoding characteristics over the recommended operating conditions and mounting tolerances. These characteristics include codewheel contribution. The typical values are average over the full rotation of the codewheel.

Parameter	Symbol	Minimum	Typical	Maximum	Units
Pulse Width Error	ΔP		7	35	$^{\circ}e$
Logic State Width Error	ΔS		5	35	$^{\circ}e$
Phase Error	$\Delta\Phi$		2	15	$^{\circ}e$
Cycle Error	ΔC		3	15	$^{\circ}e$
Position Error	$\Delta\theta$		5	20	min. of arc
Index Pulse Width	P_0	120	180	240	$^{\circ}e$

AEDS-9240-Y00 (720 CPR)

Encoding characteristics over the recommended operating conditions and mounting tolerances. These characteristics include codewheel contribution. The typical values are average over the full rotation of the codewheel.

Parameter	Symbol	Minimum	Typical	Maximum	Units
Pulse Width Error	ΔP		7	50	$^{\circ}e$
Logic State Width Error	ΔS		5	50	$^{\circ}e$
Phase Error	$\Delta\Phi$		2	35	$^{\circ}e$
Cycle Error	ΔC		15	45	$^{\circ}e$
Position Error	$\Delta\theta$		10	20	min. of arc
Index Pulse Width	P_0	240	360	480	$^{\circ}e$

Commutation Characteristics (Channel U, V, W)

Encoding characteristics over the recommended operating conditions and mounting tolerances. These characteristics include codewheel contribution. The typical values are average over the full rotation of the codewheel.

Parameter	Symbol	Minimum	Maximum	Units
Commutation Format		Three Phase 4, 6, 8, 10 poles		
Commutation Accuracy (middle of channel I to channel U)	ΔI	-1	+1	°mechanical
Commutation Accuracy (Channel U,V and W)	ΔUVW	-2	+2	°mechanical

Device Pinout

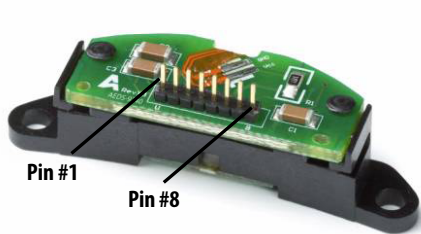

Pin #1 start from left side.

Pin	Function
1	U
2	I
3	V
4	W
5	Ground
6	Vcc
7	A
8	B

Mating Connector

Due to female connector availability, a 8 x 2 (1.27 mm x 1.27 mm) female IDC Connector is recommended. The cable used is 0.635 mm pitch flat ribbon cable.

Package Dimensions

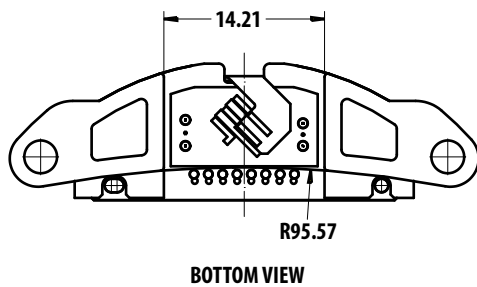
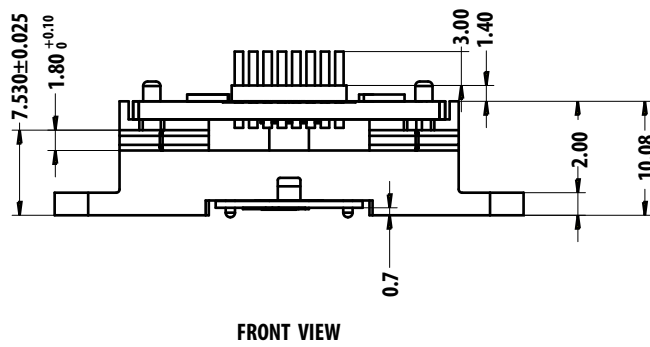
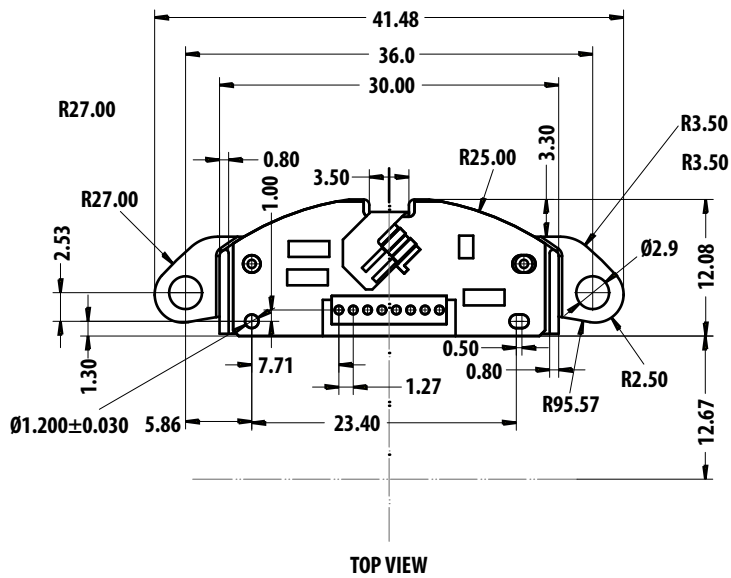

Notes:

1. Dimensions in mm unless otherwise stated
2. Linear tolerance: Up to 6mm is ± 0.15 mm, Above 6mm is ± 0.5 mm

Figure 1. Encoder module dimensions

Mounting Considerations

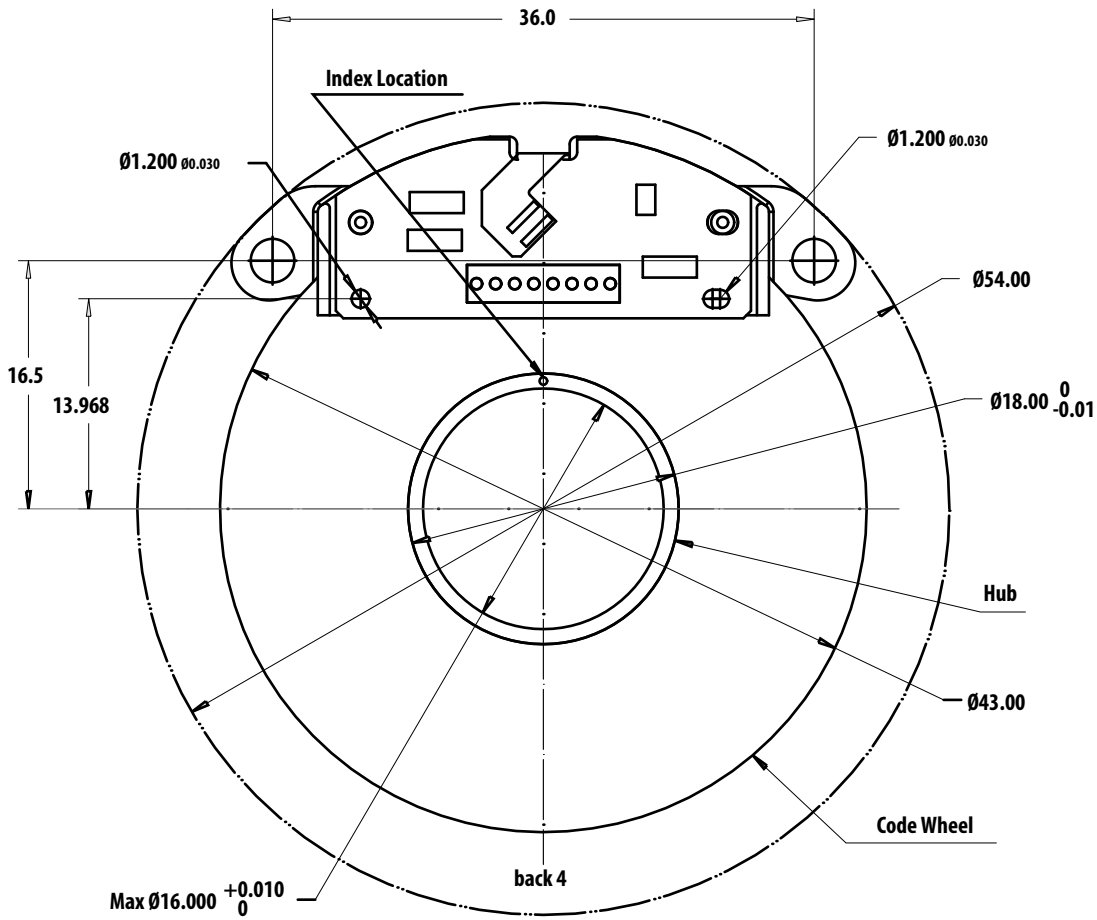

Recommended screw size : M2.5 x 0.45

Recommended mounting screw torque : 0.88 Lbin (1.0 kg-cm)

Refer to AEDS-9240 application note for step by step alignment and installation procedure

Figure 2. Encoder module with codewheel dimensions

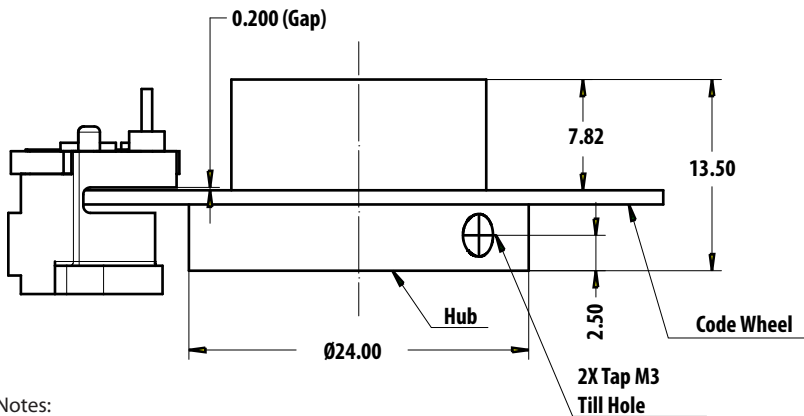

Notes:

1. All dimensions are given in mm
2. Codewheel gap is aligned at 0.200mm from detector side.

Figure 3. Encoder module with codewheel dimensions

Output Waveform Specification

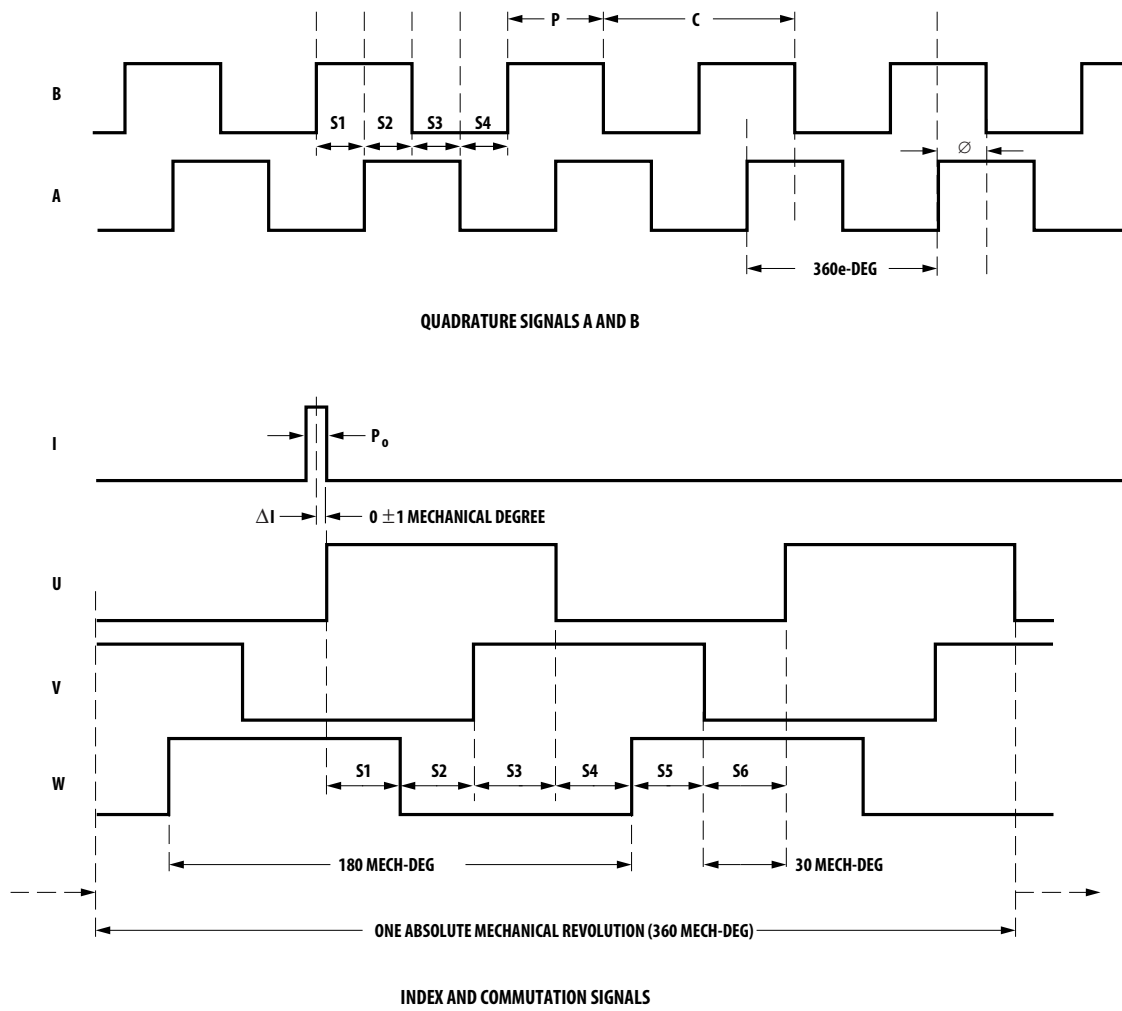
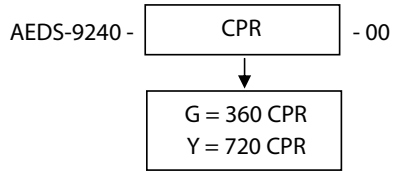

Figure 4. Output waveform specification of 2 pole-pairs (4 poles) for counter clockwise rotation, viewed from the top

Note: In the above waveform, quadrature signals A, B are not drawn to scale with respect to index pulse and commutation signals.

Ordering Information

Encoder Only



Alignment Tool

HEDS-8953 – Alignment tool for 360/720 CPR

For product information and a complete list of distributors, please go to our web site: www.avagotech.com

Avago, Avago Technologies, and the A logo are trademarks of Avago Technologies, Limited in the United States and other countries. Data subject to change. Copyright © 2007 Avago Technologies Limited. All rights reserved.
AV02-0994EN - February 20, 2008

Avago
TECHNOLOGIES

Looking for pricing, stock, or lifecycle information?

Click below to explore more details on WIN SOURCE:

 [View AEDS-9240-G00 on WIN SOURCE](#)

 [Broadcom Limited Information](#)

Optimize Your Supply Chain with WIN SOURCE Solutions

-  Global Sourcing Solution
-  Obsolete Management
-  Cost Control Management
-  Shortage Management
-  Alternative Solution
-  Excess Inventory Management