



# TPA3251 175-W Stereo, 350-W Mono PurePath™ Ultra-HD Analog-Input Class-D Amplifier

## 1 Features

- Differential Analog Inputs
- Total Output Power at 10%THD+N
  - 175-W Stereo into 4 Ω in BTL Configuration
  - 220-W Stereo into 3 Ω in BTL Configuration
  - 350-W Mono into 2 Ω in PBTL Configuration
- Total Output Power at 1%THD+N
  - 140-W Stereo into 4 Ω in BTL Configuration
  - 175-W Stereo into 3 Ω in BTL Configuration
  - 285-W Mono into 2 Ω in PBTL Configuration
- Advanced Integrated Feedback Design with High-speed Gate Driver Error Correction (PurePath™ Ultra-HD)
  - Signal Bandwidth up to 100 kHz for High Frequency Content From HD Sources
  - Ultra Low 0.005% THD+N at 1 W into 4 Ω and <0.01% THD+N to Clipping
  - 60 dB PSRR (BTL, No Input Signal)
  - <60 μV (A-Weighted) Output Noise
  - >111 dB (A Weighted) SNR
- Multiple Configurations Possible:
  - Stereo, Mono, 2.1 and 4xSE
- Click and Pop Free Startup and Stop
- 90% Efficient Class-D Operation (4 Ω)
- Wide 12-V to 36-V Supply Voltage Operation
- Self-Protection Design (Including Undervoltage, Overtemperature, Clipping, and Short Circuit Protection) With Error Reporting
- EMI Compliant When Used With Recommended System Design

## 2 Applications

- Blu-ray Disk™ / DVD Receivers
- High End HTiB Systems
- AV Receivers
- High End Soundbar
- Mini Combo Systems
- Active Speakers and Subwoofers

## 3 Description

TPA3251 is a high performance class-D power amplifier that enables true premium sound quality with class-D efficiency. It features an advanced integrated feedback design and proprietary high-speed gate driver error correction (PurePath™ Ultra-HD). This technology allows ultra low distortion across the audio band and superior audio quality. The device can drive up to 2 x 175 W into 4-Ω load and 2 x 220 W into 3-Ω load and features a 2 VRMS analog input interface that works seamlessly with high performance DACs such as TI's PCM5242. In addition to excellent audio performance, TPA3251 achieves both high power efficiency and very low power stage idle losses below 1 W. This is achieved through the use of 60 mΩ MOSFETs and an optimized gate driver scheme that achieves significantly lower idle losses than typical discrete implementations.

### Device Information<sup>(1)</sup>

| PART NUMBER | PACKAGE     | BODY SIZE (NOM)  |
|-------------|-------------|------------------|
| TPA3251     | HTSSOP (44) | 6.10mm x 14.00mm |

(1) For all available packages, see the orderable addendum at the end of the datasheet.

### Simplified Schematic

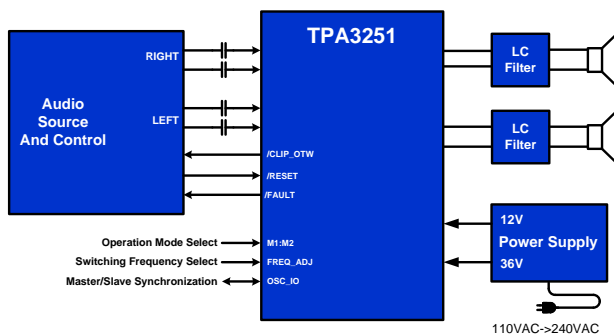

### Total Harmonic Distortion

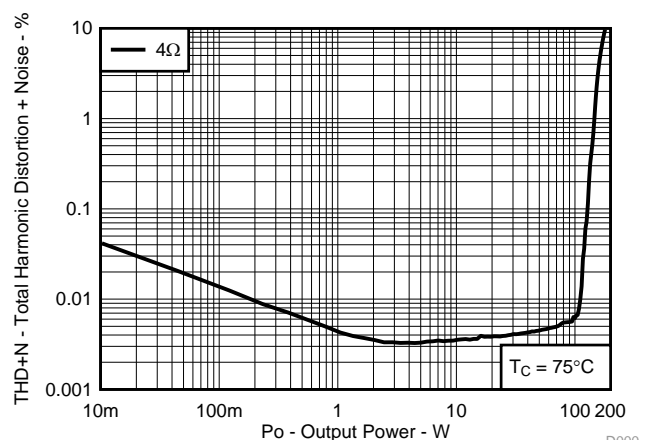

D000



## Table of Contents

|  |           |  |           |
|--|-----------|--|-----------|
| <b>1 Features</b> .....                                | <b>1</b>  | 9.2 Functional Block Diagrams .....                              | <b>15</b> |
| <b>2 Applications</b> .....                            | <b>1</b>  | 9.3 Feature Description .....                                    | <b>17</b> |
| <b>3 Description</b> .....                             | <b>1</b>  | 9.4 Device Protection System .....                               | <b>17</b> |
| <b>4 Revision History</b> .....                        | <b>2</b>  | <b>10 Application and Implementation</b> .....                   | <b>21</b> |
| <b>5 Device Comparison Table</b> .....                 | <b>3</b>  | 10.1 Application Information .....                               | <b>21</b> |
| <b>6 Pin Configuration and Functions</b> .....         | <b>3</b>  | 10.2 Typical Applications .....                                  | <b>21</b> |
| <b>7 Specifications</b> .....                          | <b>5</b>  | <b>11 Power Supply Recommendations</b> .....                     | <b>27</b> |
| 7.1 Absolute Maximum Ratings .....                     | <b>5</b>  | 11.1 Power Supplies .....  | <b>27</b> |
| 7.2 ESD Ratings .....                                  | <b>5</b>  | 11.2 Powering Up .....   | <b>28</b> |
| 7.3 Recommended Operating Conditions .....             | <b>6</b>  | 11.3 Powering Down .....   | <b>29</b> |
| 7.4 Thermal Information .....                          | <b>6</b>  | <b>12 Layout</b> .....   | <b>29</b> |
| 7.5 Electrical Characteristics .....                   | <b>7</b>  | 12.1 Layout Guidelines .....                                     | <b>29</b> |
| 7.6 Audio Characteristics (BTL) .....                  | <b>8</b>  | 12.2 Layout Examples .....                                       | <b>30</b> |
| 7.7 Audio Characteristics (SE) .....                   | <b>9</b>  | <b>13 Device and Documentation Support</b> .....                 | <b>33</b> |
| 7.8 Audio Characteristics (PBTL) .....                 | <b>9</b>  | 13.1 Documentation Support .....                                 | <b>33</b> |
| 7.9 Typical Characteristics, BTL Configuration .....   | <b>10</b> | 13.2 Community Resources .....                                   | <b>33</b> |
| 7.10 Typical Characteristics, SE Configuration .....   | <b>12</b> | 13.3 Trademarks .....  | <b>33</b> |
| 7.11 Typical Characteristics, PBTL Configuration ..... | <b>13</b> | 13.4 Electrostatic Discharge Caution .....                       | <b>33</b> |
| <b>8 Parameter Measurement Information</b> .....       | <b>14</b> | 13.5 Glossary .....  | <b>33</b> |
| <b>9 Detailed Description</b> .....                    | <b>14</b> | <b>14 Mechanical, Packaging, and Orderable Information</b> ..... | <b>33</b> |
| 9.1 Overview .....                                     | <b>14</b> |  |           |

## 4 Revision History

NOTE: Page numbers for previous revisions may differ from page numbers in the current version.

| <b>Changes from Revision C (June 2015) to Revision D</b>               | <b>Page</b> |
|--|-------------|
| • Changed the datasheet device number From: TPA3251D2 To TPA3251 ..... | <b>1</b>    |

---

| <b>Changes from Revision B (June 2015) to Revision C</b>              | <b>Page</b> |
|---|-------------|
| • Changed from a one page Product Preview to the full datasheet ..... | <b>1</b>    |

---

| <b>Changes from Revision A (June 2015) to Revision B</b>  | <b>Page</b> |
|---|-------------|
| • Changed <i>Features</i> list item From: 80 dB PSRR (BTL, No Input Signal) To: 60 dB PSRR (BTL, No Input Signal) ..... | <b>1</b>    |
| • Changed <i>Features</i> list item From: >112 dB (A Weighted) SNR To: >111 dB (A Weighted) SNR .....                   | <b>1</b>    |

---

| <b>Changes from Original (May 2015) to Revision A</b>   | <b>Page</b> |
|---|-------------|
| • Changed the <i>Features</i> list for <i>Total Output Power at 1%THD+N</i> .....   | <b>1</b>    |
| • Changed the <i>Features</i> list item <i>Advanced Integrated Feedback Design</i> .....  | <b>1</b>    |
| • Changed the <i>Features</i> list item From: <65 $\mu$ V (A-Weighted) Output Noise To: <60 $\mu$ V (A-Weighted) Output Noise ..... | <b>1</b>    |
| • Changed the <i>Features</i> list for <i>Multiple Configurations Possible</i> .....  | <b>1</b>    |
| • Changed the <i>Description</i> .....  | <b>1</b>    |
| • Added the <i>Simplified Schematic</i> .....   | <b>1</b>    |

## 5 Device Comparison Table

| DEVICE NAME | DESCRIPTION  |
|-------------|--|
| TAS5630B    | 300-W Stereo Class-D PurePath™ HD Analog Input Audio Power Amplifier |
| TAS5613A    | 150-W Stereo Class-D PurePath™ HD Analog Input Audio Power Amplifier |
| TAS5611A    | 125-W Stereo Class-D PurePath™ HD Analog Input Audio Power Amplifier |

## 6 Pin Configuration and Functions

The TPA3251 is available in a thermally enhanced TSSOP package.

The package type contains a heat slug that is located on the top side of the device for convenient thermal coupling to the heat sink.

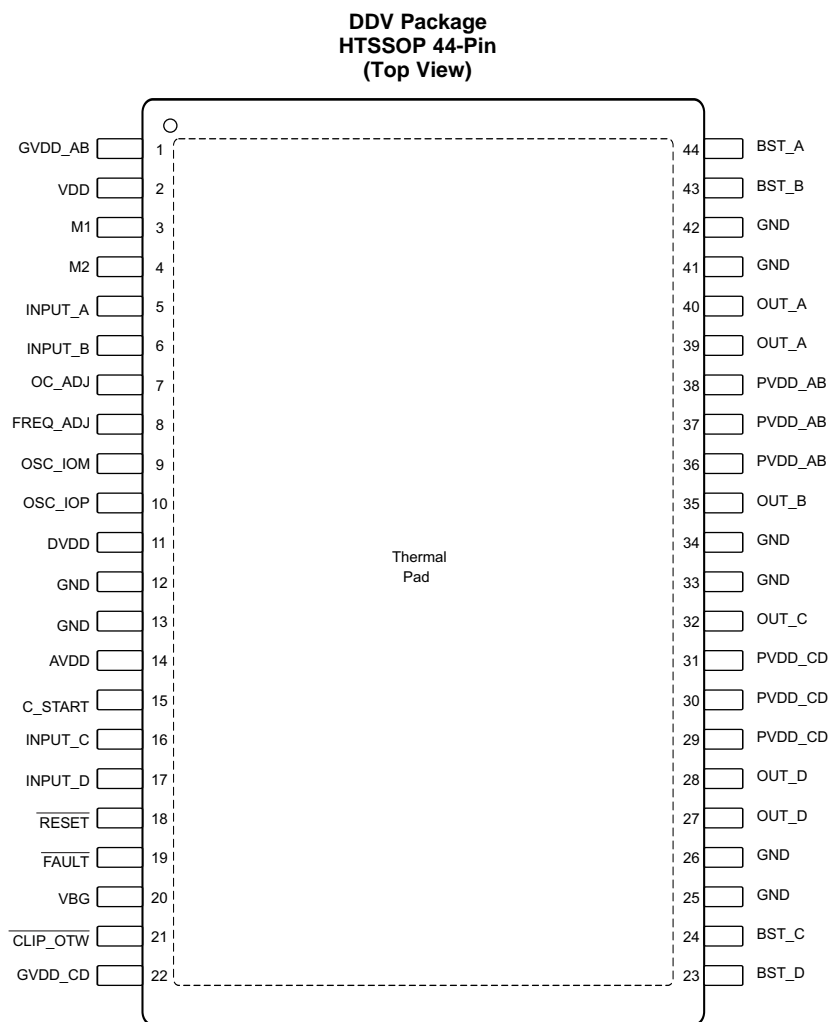

### Pin Functions

| NAME      | NO.                            | I/O <sup>(1)</sup> | DESCRIPTION   |
|-----------|--------------------------------|--------------------|---|
| AVDD      | 14                             | P                  | Internal voltage regulator, analog section  |
| BST_A     | 44                             | P                  | HS bootstrap supply (BST), external 0.033 $\mu$ F capacitor to OUT_A required.  |
| BST_B     | 43                             | P                  | HS bootstrap supply (BST), external 0.033 $\mu$ F capacitor to OUT_B required.  |
| BST_C     | 24                             | P                  | HS bootstrap supply (BST), external 0.033 $\mu$ F capacitor to OUT_C required.  |
| BST_D     | 23                             | P                  | HS bootstrap supply (BST), external 0.033 $\mu$ F capacitor to OUT_D required.  |
| CLIP_OTW  | 21                             | O                  | Clipping warning and Over-temperature warning; open drain; active low   |
| C_START   | 15                             | O                  | Startup ramp, requires a charging capacitor to GND  |
| DVDD      | 11                             | P                  | Internal voltage regulator, digital section   |
| FAULT     | 19                             | O                  | Shutdown signal, open drain; active low   |
| FREQ_ADJ  | 8                              | O                  | Oscillator frequency programming pin  |
| GND       | 12, 13, 25, 26, 33, 34, 41, 42 | P                  | Ground  |
| GVDD_AB   | 1                              | P                  | Gate-drive voltage supply; AB-side, requires 0.1 $\mu$ F capacitor to GND   |
| GVDD_CD   | 22                             | P                  | Gate-drive voltage supply; CD-side, requires 0.1 $\mu$ F capacitor to GND   |
| INPUT_A   | 5                              | I                  | Input signal for half bridge A  |
| INPUT_B   | 6                              | I                  | Input signal for half bridge B  |
| INPUT_C   | 16                             | I                  | Input signal for half bridge C  |
| INPUT_D   | 17                             | I                  | Input signal for half bridge D  |
| M1        | 3                              | I                  | Mode selection 1 (LSB)  |
| M2        | 4                              | I                  | Mode selection 2 (MSB)  |
| OC_ADJ    | 7                              | I/O                | Over-Current threshold programming pin  |
| OSC_IOM   | 9                              | I/O                | Oscillator synchronization interface  |
| OSC_IOP   | 10                             | O                  | Oscillator synchronization interface  |
| OUT_A     | 39, 40                         | O                  | Output, half bridge A   |
| OUT_B     | 35                             | O                  | Output, half bridge B   |
| OUT_C     | 32                             | O                  | Output, half bridge C   |
| OUT_D     | 27, 28                         | O                  | Output, half bridge D   |
| PVDD_AB   | 36, 37, 38                     | P                  | PVDD supply for half-bridge A and B   |
| PVDD_CD   | 29, 30, 31                     | P                  | PVDD supply for half-bridge C and D   |
| RESET     | 18                             | I                  | Device reset Input; active low  |
| VDD       | 2                              | P                  | Power supply for internal voltage regulator requires a 10- $\mu$ F capacitor with a 0.1- $\mu$ F capacitor to GND for decoupling. |
| VBG       | 20                             | P                  | Internal voltage reference requires a 0.1- $\mu$ F capacitor to GND for decoupling.   |
| PowerPad™ |                                | P                  | Ground, connect to grounded heat sink   |

(1) I=Input, O=Output, I/O= Input/Output, P=Power

**Table 1. Mode Selection Pins**

| MODE PINS |    | INPUT MODE <sup>(1)</sup> | OUTPUT CONFIGURATION | DESCRIPTION   |
|-----------|----|---------------------------|----------------------|---|
| M2        | M1 |                           |                      |   |
| 0         | 0  | 2N + 1                    | 2 x BTL              | Stereo BTL output configuration                                   |
| 0         | 1  | 2N/1N + 1                 | 1 x BTL + 2 x SE     | 2.1 BTL + SE mode   |
| 1         | 0  | 2N + 1                    | 1 x PBTL             | Paralleled BTL configuration. Connect INPUT_C and INPUT_D to GND. |
| 1         | 1  | 1N + 1                    | 4 x SE               | Single ended output configuration                                 |

(1) 2N refers to differential input signal, 1N refers to single ended input signal. +1 refers to number of logic control (RESET) input pins.

## 7 Specifications

### 7.1 Absolute Maximum Ratings

over operating free-air temperature range (unless otherwise noted) <sup>(1)</sup>

|                  |   | MIN  | MAX  | UNIT |
|------------------|---|------|------|------|
| Supply voltage   | BST_X to GVDD_X <sup>(2)</sup>                                      | -0.3 | 50   | V    |
|                  | VDD to GND  | -0.3 | 13.2 | V    |
|                  | GVDD_X to GND <sup>(2)</sup>  | -0.3 | 13.2 | V    |
|                  | PVDD_X to GND <sup>(2)</sup>  | -0.3 | 50   | V    |
|                  | DVDD to GND   | -0.3 | 4.2  | V    |
|                  | AVDD to GND   | -0.3 | 8.5  | V    |
|                  | VBG to GND  | -0.3 | 4.2  | V    |
| Interface pins   | OUT_X to GND <sup>(2)</sup>   | -0.3 | 50   | V    |
|                  | BST_X to GND <sup>(2)</sup>   | -0.3 | 62.5 | V    |
|                  | OC_ADJ, M1, M2, OSC_IOP, OSC_IOM, FREQ_ADJ, C_START, to GND         | -0.3 | 4.2  | V    |
|                  | RESET, FAULT, CLIP_OTW, CLIP to GND                                 | -0.3 | 4.2  | V    |
|                  | INPUT_X to GND  | -0.3 | 7    | V    |
|                  | Continuous sink current, RESET, FAULT, CLIP_OTW, CLIP, RESET to GND |      | 9    | mA   |
| T <sub>J</sub>   | Operating junction temperature range                                | 0    | 150  | °C   |
| T <sub>stg</sub> | Storage temperature range   | -40  | 150  | °C   |

- (1) Stresses beyond those listed under *Absolute Maximum Ratings* may cause permanent damage to the device. These are stress ratings only, which do not imply functional operation of the device at these or any other conditions beyond those indicated under *Recommended Operating Conditions*. Exposure to absolute-maximum-rated conditions for extended periods may affect device reliability.
- (2) These voltages represents the DC voltage + peak AC waveform measured at the terminal of the device in all conditions.

### 7.2 ESD Ratings

|                  |                         |  | VALUE | UNIT |
|------------------|-------------------------|--|-------|------|
| V <sub>ESD</sub> | Electrostatic discharge | Human body model (HBM), per ANSI/ESDA/JEDEC JS-001, all pins <sup>(1)</sup>              | ±2000 | V    |
|                  |                         | Charged device model (CDM), per JEDEC specification JESD22-C101, all pins <sup>(2)</sup> | ±500  | V    |

- (1) JEDEC document JEP155 states that 500-V HBM allows safe manufacturing with a standard ESD control process.
- (2) JEDEC document JEP157 states that 250-V CDM allows safe manufacturing with a standard ESD control process.

### 7.3 Recommended Operating Conditions

over operating free-air temperature range (unless otherwise noted)

|                           |  |   | MIN  | TYP | MAX  | UNIT |
|---------------------------|--|---|------|-----|------|------|
| PVDD_x                    | Half-bridge supply   | DC supply voltage                                       | 12   | 36  | 38   | V    |
| GVDD_x                    | Supply for logic regulators and gate-drive circuitry                           | DC supply voltage                                       | 10.8 | 12  | 13.2 | V    |
| VDD                       | Digital regulator supply voltage   | DC supply voltage                                       | 10.8 | 12  | 13.2 | V    |
| R <sub>L</sub> (BTL)      | Load impedance   | Output filter inductance within recommended value range | 2.7  | 4   |      | Ω    |
| R <sub>L</sub> (SE)       |  |   | 1.5  | 3   |      |      |
| R <sub>L</sub> (PBTL)     |  |   | 1.6  | 2   |      |      |
| L <sub>OUT</sub> (BTL)    | Output filter inductance   | Minimum output inductance at I <sub>OC</sub>            | 5    |     |      | μH   |
| L <sub>OUT</sub> (SE)     |  |   | 5    |     |      |      |
| L <sub>OUT</sub> (PBTL)   |  |   | 5    |     |      |      |
| F <sub>PWM</sub>          | PWM frame rate selectable for AM interference avoidance; 1% Resistor tolerance | Nominal   | 575  | 600 | 625  | kHz  |
|                           |  | AM1   | 475  | 500 | 525  |      |
|                           |  | AM2   | 430  | 450 | 470  |      |
| R <sub>(FREQ_ADJ)</sub>   | PWM frame rate programming resistor  | Nominal; Master mode                                    | 9.9  | 10  | 10.1 | kΩ   |
|                           |  | AM1; Master mode  | 19.8 | 20  | 20.2 |      |
|                           |  | AM2; Master mode  | 29.7 | 30  | 30.3 |      |
| C <sub>PVDD</sub>         | PVDD close decoupling capacitors   |   | 1.0  |     | μF   |      |
| R <sub>OC</sub>           | Over-current programming resistor  | Resistor tolerance = 5%                                 | 22   |     | 30   | kΩ   |
| R <sub>OC</sub> (LATCHED) | Over-current programming resistor  | Resistor tolerance = 5%                                 | 47   |     | 64   | kΩ   |
| V <sub>(FREQ_ADJ)</sub>   | Voltage on FREQ_ADJ pin for slave mode operation                               | Slave mode  |      | 3.3 |      | V    |
| T <sub>J</sub>            | Junction temperature   |   | 0    |     | 125  | °C   |

### 7.4 Thermal Information

| THERMAL METRIC <sup>(1)</sup> |  | TPA3251D2                  |  | UNIT |
|-------------------------------|--|----------------------------|--|------|
|                               |  | DDV 44-PINS HTSSOP         |  |      |
|                               |  | JEDEC STANDARD 4 LAYER PCB | FIXED 85°C HEATSINK TEMPERATURE <sup>(2)</sup> |      |
| R <sub>θJA</sub>              | Junction-to-ambient thermal resistance       | 50.7                       | 2.5 <sup>(2)</sup>                             | °C/W |
| R <sub>θJC(top)</sub>         | Junction-to-case (top) thermal resistance    | 0.36                       | 0.2  |      |
| R <sub>θJB</sub>              | Junction-to-board thermal resistance         | 24.4                       | n/a  |      |
| ψ <sub>JT</sub>               | Junction-to-top characterization parameter   | 0.19                       | 0.5  |      |
| ψ <sub>JB</sub>               | Junction-to-board characterization parameter | 24.2                       | n/a  |      |
| R <sub>θJC(bot)</sub>         | Junction-to-case (bottom) thermal resistance | n/a                        | n/a  |      |

(1) For more information about traditional and new thermal metrics, see the *IC Package Thermal Metrics* application report, [SPRA953](#).

(2) Thermal data are obtained with 85°C heat sink temperature using thermal compound with 0.7W/mK thermal conductivity and 2mil thickness. In this model heat sink temperature is considered to be the ambient temperature and only path for dissipation is to the heatsink.

## 7.5 Electrical Characteristics

PVDD\_X = 36 V, GVDD\_X = 12 V, VDD = 12 V, T<sub>C</sub> (Case temperature) = 75°C, f<sub>S</sub> = 600 kHz, unless otherwise specified.

| PARAMETER   |   | TEST CONDITIONS  | MIN | TYP  | MAX  | UNIT |     |
|---|---|--|-----|------|------|------|-----|
| <b>INTERNAL VOLTAGE REGULATOR AND CURRENT CONSUMPTION</b> |   |  |     |      |      |      |     |
| DVDD  | Voltage regulator, only used as reference node  | VDD = 12 V   | 3   | 3.3  | 3.6  | V    |     |
| AVDD  | Voltage regulator, only used as reference node  | VDD = 12 V   |     | 7.8  |      | V    |     |
| I <sub>VDD</sub>  | VDD supply current  | Operating, 50% duty cycle  |     | 40   |      | mA   |     |
|   |   | Idle, reset mode   |     | 13   |      |      |     |
| I <sub>GVDD_X</sub>                                       | Gate-supply current per full-bridge   | 50% duty cycle   |     | 25   |      | mA   |     |
|   |   | Reset mode   |     | 3    |      |      |     |
| I <sub>PVDD_X</sub>                                       | PVDD idle current per full bridge   | 50% duty cycle with recommended output filter  |     | 12.5 |      | mA   |     |
|   |   | Reset mode, No switching   |     | 1    |      |      |     |
| <b>ANALOG INPUTS</b>                                      |   |  |     |      |      |      |     |
| R <sub>IN</sub>   | Input resistance  |  |     | 24   |      | kΩ   |     |
| V <sub>IN</sub>   | Maximum input voltage swing   |  |     |      | 7    | V    |     |
| I <sub>IN</sub>   | Maximum input current   |  |     |      | 1    | mA   |     |
| G   | Inverting voltage Gain  | V <sub>OUT</sub> /V <sub>IN</sub>  |     | 20   |      | dB   |     |
| <b>OSCILLATOR</b>   |   |  |     |      |      |      |     |
| f <sub>OSC(I/O+)</sub>                                    | Nominal, Master Mode  | F <sub>PWM</sub> × 6   |     | 3.45 | 3.6  | 3.75 | MHz |
|   | AM1, Master Mode  |  |     | 2.85 | 3    | 3.15 |     |
|   | AM2, Master Mode  |  |     | 2.58 | 2.7  | 2.82 |     |
| V <sub>IH</sub>   | High level input voltage  |  |     | 1.86 |      | V    |     |
| V <sub>IL</sub>   | Low level input voltage   |  |     |      | 1.45 | V    |     |
| <b>OUTPUT-STAGE MOSFETS</b>                               |   |  |     |      |      |      |     |
| R <sub>DS(on)</sub>                                       | Drain-to-source resistance, low side (LS)   | T <sub>J</sub> = 25°C, Includes metallization resistance, GVDD = 12 V                                |     | 60   | 100  | mΩ   |     |
|   | Drain-to-source resistance, high side (HS)  |  |     | 60   | 100  |      |     |
| <b>I/O PROTECTION</b>                                     |   |  |     |      |      |      |     |
| V <sub>uwp,VDD,GVDD</sub>                                 | Undervoltage protection limit, GVDD_x and VDD   |  |     | 9.5  |      | V    |     |
| V <sub>uwp,VDD, GVDD,hyst</sub> <sup>(1)</sup>            |   |  |     | 0.6  |      | V    |     |
| OTW   | Overtemperature warning, $\overline{\text{CLIP\_OTW}}$ <sup>(1)</sup>   |  |     | 115  | 125  | 135  | °C  |
| OTW <sub>hyst</sub> <sup>(1)</sup>                        | Temperature drop needed below OTW temperature for $\overline{\text{CLIP\_OTW}}$ to be inactive after OTW event. |  |     | 25   |      |      | °C  |
| OTE <sup>(1)</sup>  | Overtemperature error   |  |     | 145  | 155  | 165  | °C  |
| OTE-OTW <sub>(differential)</sub> <sup>(1)</sup>          | OTE-OTW differential  |  |     | 30   |      |      | °C  |
| OTE <sub>hyst</sub> <sup>(1)</sup>                        | A reset needs to occur for $\overline{\text{FAULT}}$ to be released following an OTE event                      |  |     | 25   |      |      | °C  |
| OLPC  | Overload protection counter   | f <sub>PWM</sub> = 600 kHz   |     | 1.7  |      |      | ms  |
| I <sub>OC</sub>   | Overcurrent limit protection  | Resistor – programmable, nominal peak current in 1Ω load, R <sub>OCP</sub> = 22 kΩ                   |     | 14   |      |      | A   |
| I <sub>OC(LATCHED)</sub>                                  | Overcurrent limit protection  | Resistor – programmable, peak current in 1Ω load, R <sub>OCP</sub> = 47kΩ                            |     | 14   |      |      | A   |
| I <sub>DCspkr</sub>                                       | DC Speaker Protection Current Threshold   | BTL current imbalance threshold  |     | 1.5  |      |      | A   |
| I <sub>OCT</sub>  | Overcurrent response time   | Time from switching transition to flip-state induced by overcurrent.                                 |     | 150  |      |      | ns  |
| I <sub>PD</sub>   | Output pulldown current of each half  | Connected when $\overline{\text{RESET}}$ is active to provide bootstrap charge. Not used in SE mode. |     | 3    |      |      | mA  |

(1) Specified by design.

### Electrical Characteristics (continued)

PVDD\_X = 36 V, GVDD\_X = 12 V, VDD = 12 V, T<sub>C</sub> (Case temperature) = 75°C, f<sub>S</sub> = 600 kHz, unless otherwise specified.

| PARAMETER                            |   | TEST CONDITIONS                 | MIN | TYP | MAX | UNIT    |
|--------------------------------------|---|---------------------------------|-----|-----|-----|---------|
| <b>STATIC DIGITAL SPECIFICATIONS</b> |   |                                 |     |     |     |         |
| V <sub>IH</sub>                      | High level input voltage                                    | M1, M2, OSC_IOP, OSC_IOM, RESET | 1.9 |     |     | V       |
| V <sub>IL</sub>                      | Low level input voltage                                     |                                 |     |     | 0.8 | V       |
| I <sub>ikg</sub>                     | Input leakage current                                       |                                 |     | 100 |     | μA      |
| <b>OTW/SHUTDOWN (FAULT)</b>          |   |                                 |     |     |     |         |
| R <sub>INT_PU</sub>                  | Internal pullup resistance, CLIP_OTW to DVDD, FAULT to DVDD |                                 | 20  | 26  | 32  | kΩ      |
| V <sub>OH</sub>                      | High level output voltage                                   | Internal pullup resistor        | 3   | 3.3 | 3.6 | V       |
| V <sub>OL</sub>                      | Low level output voltage                                    | I <sub>O</sub> = 4 mA           |     | 200 | 500 | mV      |
| Device fanout                        | CLIP_OTW, FAULT   | No external pullup              |     | 30  |     | devices |

### 7.6 Audio Characteristics (BTL)

PCB and system configuration are in accordance with recommended guidelines. Audio frequency = 1 kHz, PVDD\_X = 36 V, GVDD\_X = 12 V, R<sub>L</sub> = 4 Ω, f<sub>S</sub> = 600 kHz, R<sub>OC</sub> = 22 kΩ, T<sub>C</sub> = 75°C, Output Filter: L<sub>DEM</sub> = 10 μH, C<sub>DEM</sub> = 1 μF, mode = 00, AES17 + AUX-0025 measurement filters, unless otherwise noted.

| PARAMETER         |   | TEST CONDITIONS   | MIN | TYP    | MAX | UNIT |
|-------------------|---|---|-----|--------|-----|------|
| P <sub>O</sub>    | Power output per channel                                    | R <sub>L</sub> = 3 Ω, 10% THD+N                         |     | 220    |     | W    |
|                   |   | R <sub>L</sub> = 4 Ω, 10% THD+N                         |     | 175    |     |      |
|                   |   | R <sub>L</sub> = 3 Ω, 1% THD+N                          |     | 175    |     |      |
|                   |   | R <sub>L</sub> = 4 Ω, 1% THD+N                          |     | 140    |     |      |
| THD+N             | Total harmonic distortion + noise                           | 1 W   |     | 0.005% |     |      |
| V <sub>n</sub>    | Output integrated noise                                     | A-weighted, AES17 filter, Input Capacitor Grounded      |     | 60     |     | μV   |
| V <sub>OS</sub>   | Output offset voltage                                       | Inputs AC coupled to GND                                |     | 20     | 60  | mV   |
| SNR               | Signal-to-noise ratio <sup>(1)</sup>                        |   |     | 111    |     | dB   |
| DNR               | Dynamic range   |   |     | 115    |     | dB   |
| P <sub>idle</sub> | Power dissipation due to Idle losses (I <sub>PVDD_X</sub> ) | P <sub>O</sub> = 0, 4 channels switching <sup>(2)</sup> |     | 1      |     | W    |

- (1) SNR is calculated relative to 1% THD+N output level.
- (2) Actual system idle losses also are affected by core losses of output inductors.

## 7.7 Audio Characteristics (SE)

PCB and system configuration are in accordance with recommended guidelines. Audio frequency = 1 kHz, PVDD\_X = 36 V, GVDD\_X = 12 V, R<sub>L</sub> = 2 Ω, f<sub>s</sub> = 600 kHz, R<sub>OC</sub> = 22 kΩ, T<sub>C</sub> = 75°C, Output Filter: L<sub>DEM</sub> = 15 μH, C<sub>DEM</sub> = 1 μF, MODE = 11, AES17 + AUX-0025 measurement filters, unless otherwise noted.

| PARAMETER         |  | TEST CONDITIONS   | MIN | TYP    | MAX | UNIT |
|-------------------|--|---|-----|--------|-----|------|
| P <sub>O</sub>    | Power output per channel                       | R <sub>L</sub> = 2 Ω, 10% THD+N                         |     | 84     |     | W    |
|                   |  | R <sub>L</sub> = 3 Ω, 10% THD+N                         |     | 60     |     |      |
|                   |  | R <sub>L</sub> = 4 Ω, 10% THD+N                         |     | 47     |     |      |
|                   |  | R <sub>L</sub> = 2 Ω, 1% THD+N                          |     | 67     |     |      |
|                   |  | R <sub>L</sub> = 3 Ω, 1% THD+N                          |     | 48     |     |      |
|                   |  | R <sub>L</sub> = 4 Ω, 1% THD+N                          |     | 37     |     |      |
| THD+N             | Total harmonic distortion + noise              | 1 W   |     | 0.015% |     |      |
| V <sub>n</sub>    | Output integrated noise                        | A-weighted, AES17 filter, Input Capacitor Grounded      |     | 115    |     | μV   |
| SNR               | Signal to noise ratio <sup>(1)</sup>           | A-weighted  |     | 100    |     | dB   |
| DNR               | Dynamic range                                  | A-weighted  |     | 101    |     | dB   |
| P <sub>idle</sub> | Power dissipation due to idle losses (IPVDD_X) | P <sub>O</sub> = 0, 4 channels switching <sup>(2)</sup> |     | 0.5    |     | W    |

(1) SNR is calculated relative to 1% THD+N output level.

(2) Actual system idle losses are affected by core losses of output inductors.

## 7.8 Audio Characteristics (PBTTL)

PCB and system configuration are in accordance with recommended guidelines. Audio frequency = 1 kHz, PVDD\_X = 36 V, GVDD\_X = 12 V, R<sub>L</sub> = 2 Ω, f<sub>s</sub> = 600 kHz, R<sub>OC</sub> = 22 kΩ, T<sub>C</sub> = 75°C, Output Filter: L<sub>DEM</sub> = 10 μH, C<sub>DEM</sub> = 1 μF, MODE = 10, AES17 + AUX-0025 measurement filters, unless otherwise noted.

| PARAMETER         |  | TEST CONDITIONS   | MIN | TYP   | MAX | UNIT |
|-------------------|--|---|-----|-------|-----|------|
| P <sub>O</sub>    | Power output per channel                       | R <sub>L</sub> = 2 Ω, 10% THD+N                         |     | 355   |     | W    |
|                   |  | R <sub>L</sub> = 3 Ω, 10% THD+N                         |     | 250   |     |      |
|                   |  | R <sub>L</sub> = 4 Ω, 10% THD+N                         |     | 195   |     |      |
|                   |  | R <sub>L</sub> = 2 Ω, 1% THD+N                          |     | 285   |     |      |
|                   |  | R <sub>L</sub> = 3 Ω, 1% THD+N                          |     | 200   |     |      |
|                   |  | R <sub>L</sub> = 4 Ω, 1% THD+N                          |     | 155   |     |      |
| THD+N             | Total harmonic distortion + noise              | 1 W   |     | 0.05% |     |      |
| V <sub>n</sub>    | Output integrated noise                        | A-weighted, AES17 filter, Input Capacitor Grounded      |     | 62    |     | μV   |
| SNR               | Signal to noise ratio <sup>(1)</sup>           | A-weighted  |     | 111   |     | dB   |
| DNR               | Dynamic range                                  | A-weighted  |     | 111   |     | dB   |
| P <sub>idle</sub> | Power dissipation due to idle losses (IPVDD_X) | P <sub>O</sub> = 0, 4 channels switching <sup>(2)</sup> |     | 1     |     | W    |

(1) SNR is calculated relative to 1% THD+N output level.

(2) Actual system idle losses are affected by core losses of output inductors.

### 7.9 Typical Characteristics, BTL Configuration

All Measurements taken at audio frequency = 1 kHz, PVDD\_X = 36 V, GVDD\_X = 12 V, R<sub>L</sub> = 4 Ω, f<sub>S</sub> = 600 kHz, R<sub>OC</sub> = 22 kΩ, T<sub>C</sub> = 75°C, Output Filter: L<sub>DEM</sub> = 10 μH, C<sub>DEM</sub> = 1 μF, mode = 00, AES17 + AUX-0025 measurement filters, unless otherwise noted.

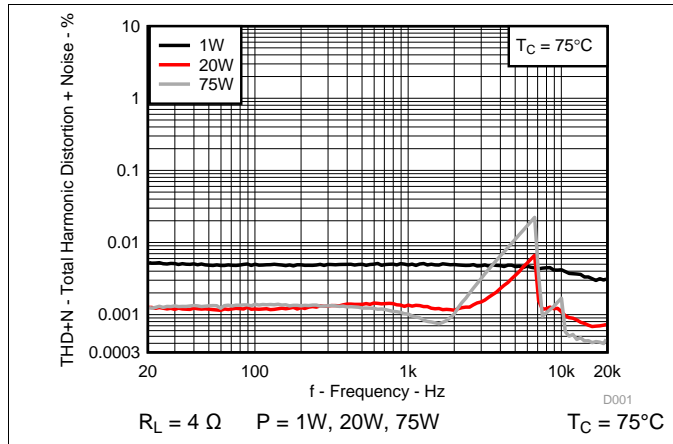

Figure 1. Total Harmonic Distortion+Noise vs Frequency

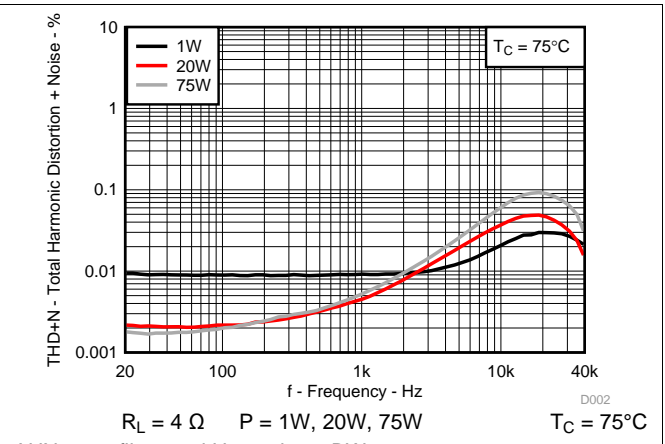

Figure 2. Total Harmonic Distortion+Noise vs Frequency

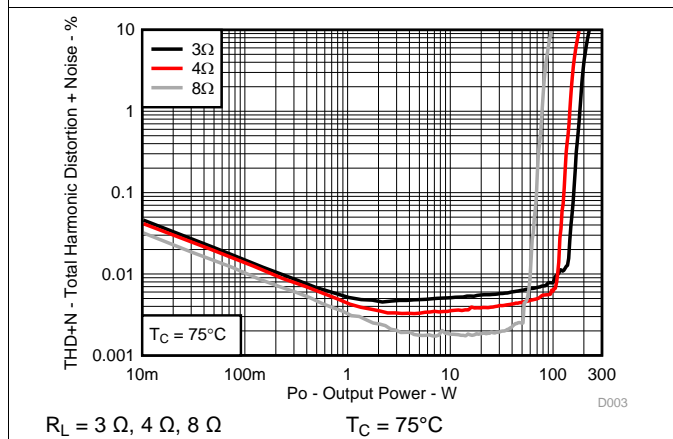

Figure 3. Total Harmonic Distortion + Noise vs Output Power

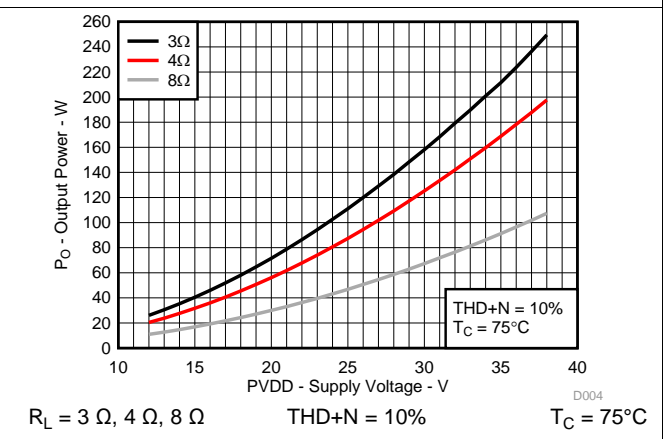

Figure 4. Output Power vs Supply Voltage

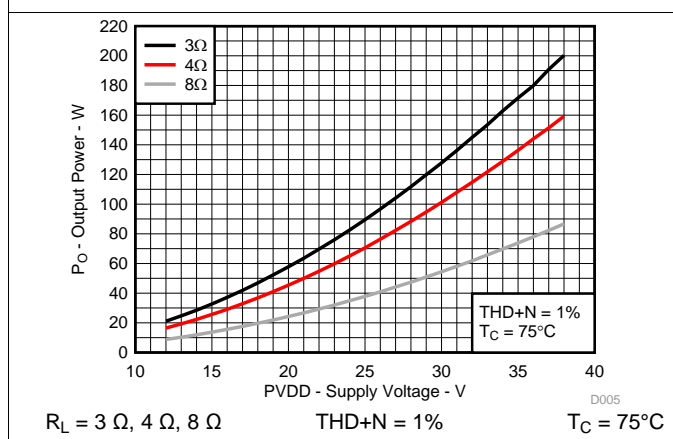

Figure 5. Output Power vs Supply Voltage

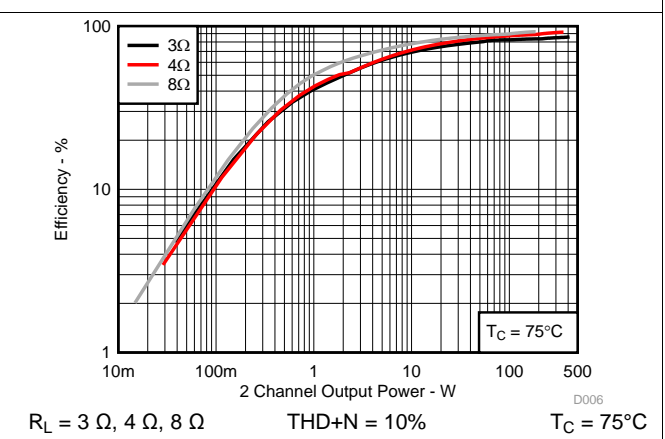

Figure 6. System Efficiency vs Output Power

Typical Characteristics, BTL Configuration (continued)

All Measurements taken at audio frequency = 1 kHz, PVDD\_X = 36 V, GVDD\_X = 12 V, R<sub>L</sub> = 4 Ω, f<sub>S</sub> = 600 kHz, R<sub>OC</sub> = 22 kΩ, T<sub>C</sub> = 75°C, Output Filter: L<sub>DEM</sub> = 10 μH, C<sub>DEM</sub> = 1 μF, mode = 00, AES17 + AUX-0025 measurement filters, unless otherwise noted.

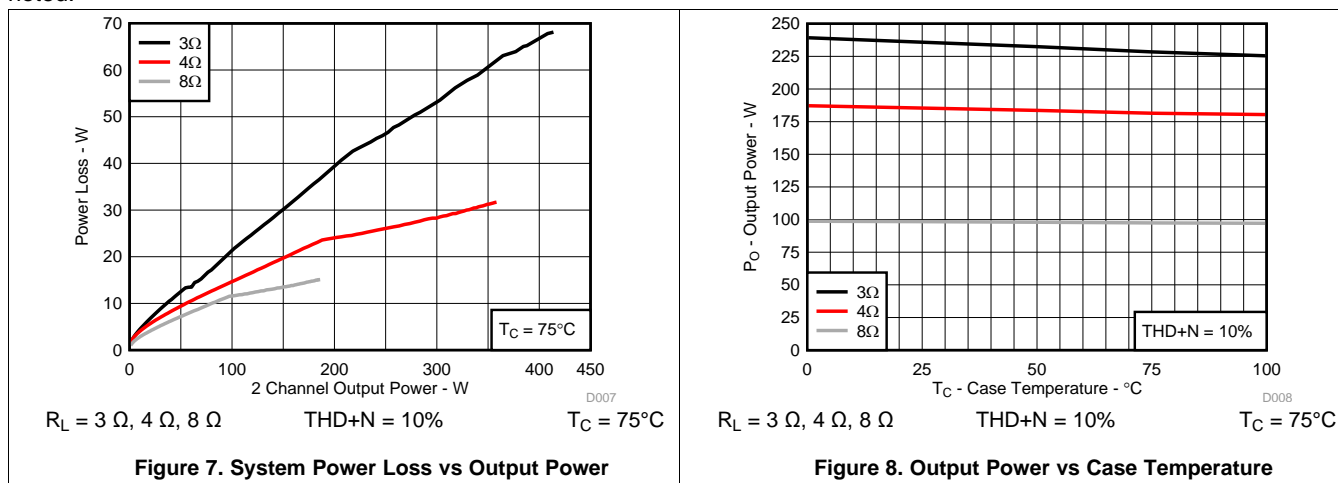

Figure 7. System Power Loss vs Output Power

Figure 8. Output Power vs Case Temperature

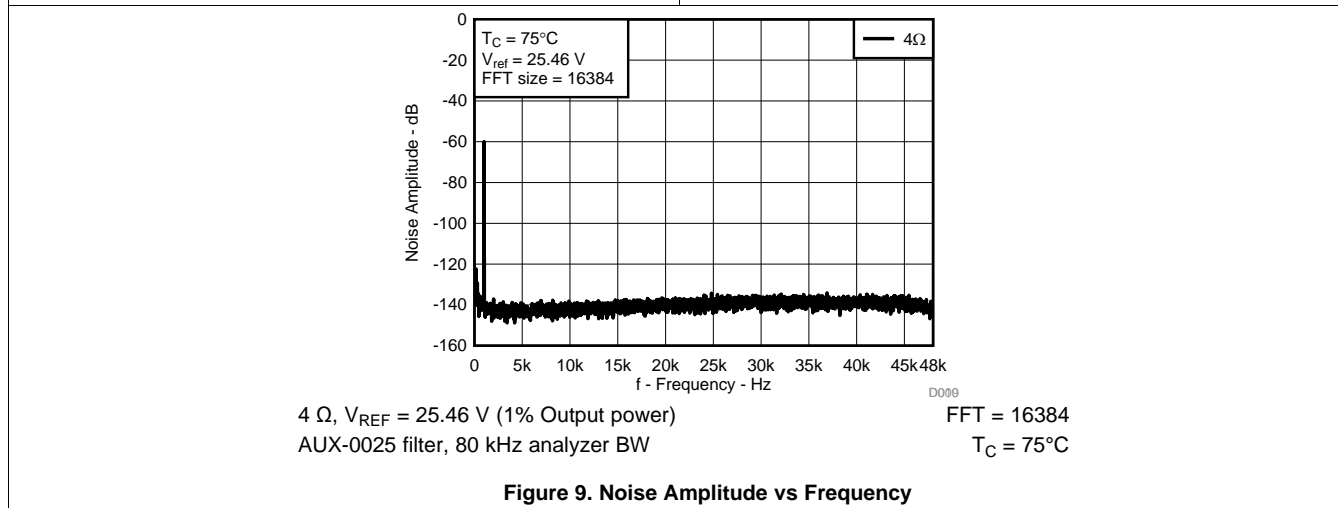
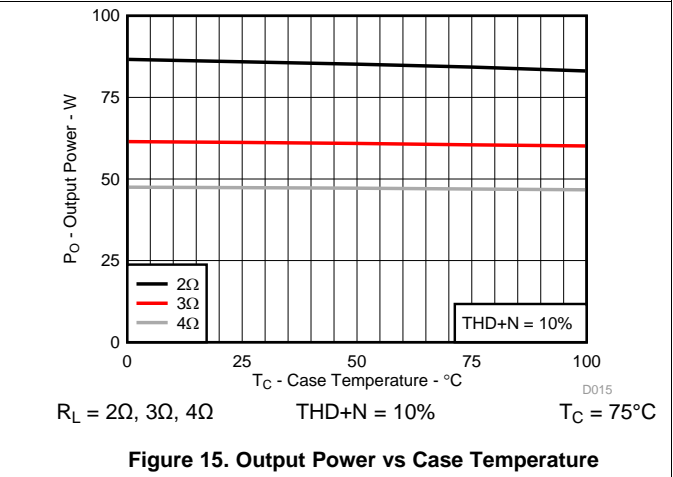
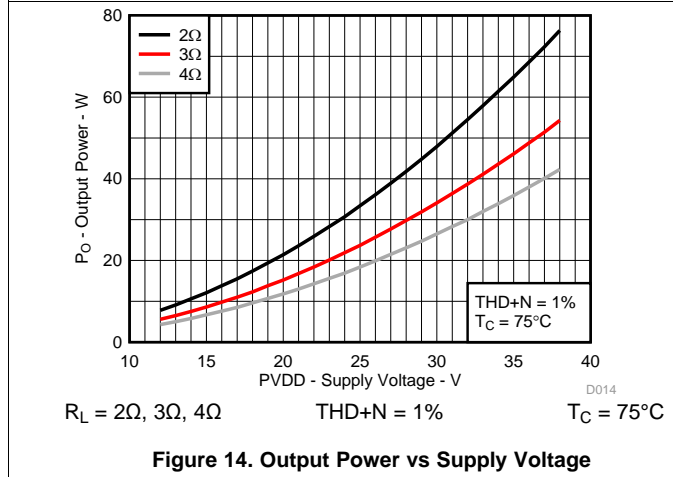
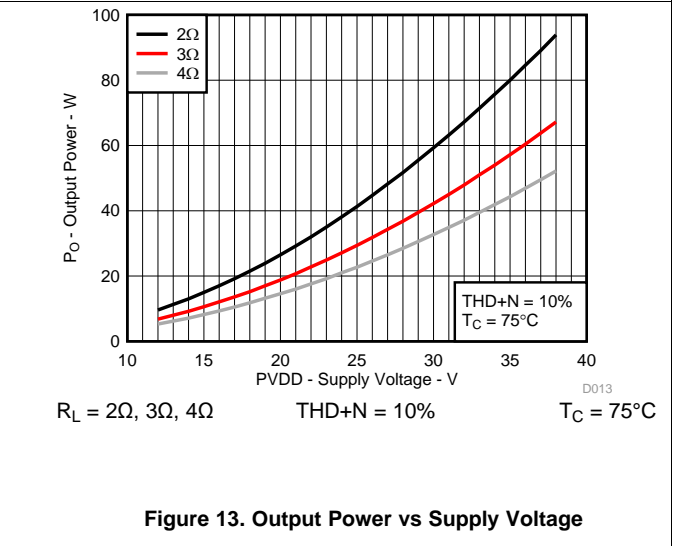
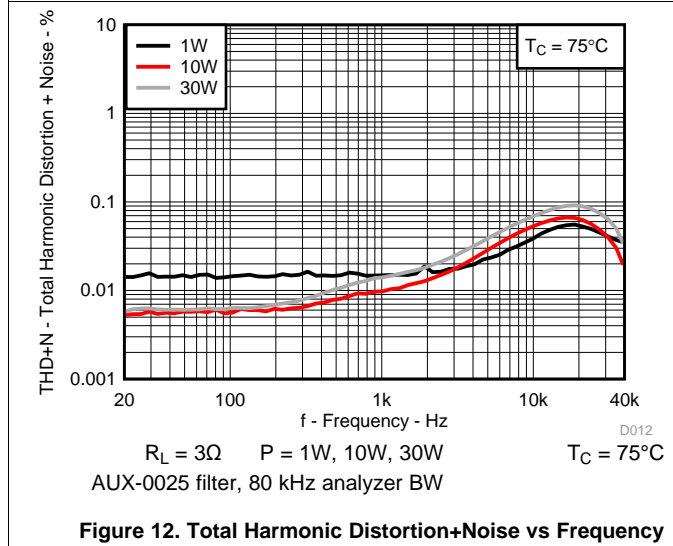
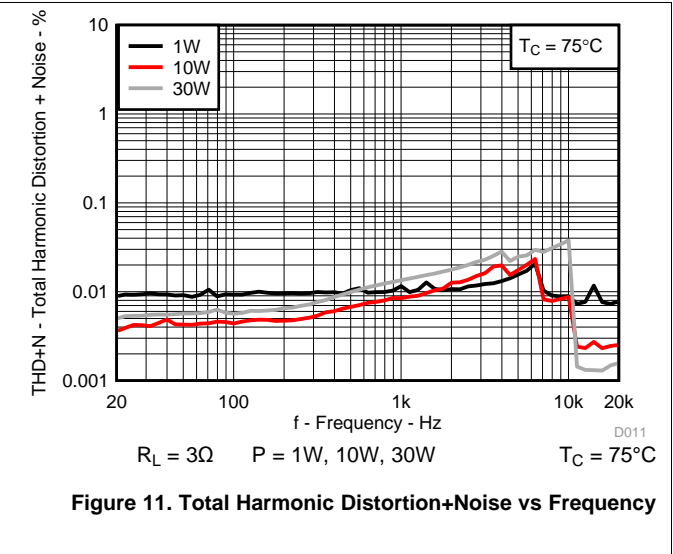
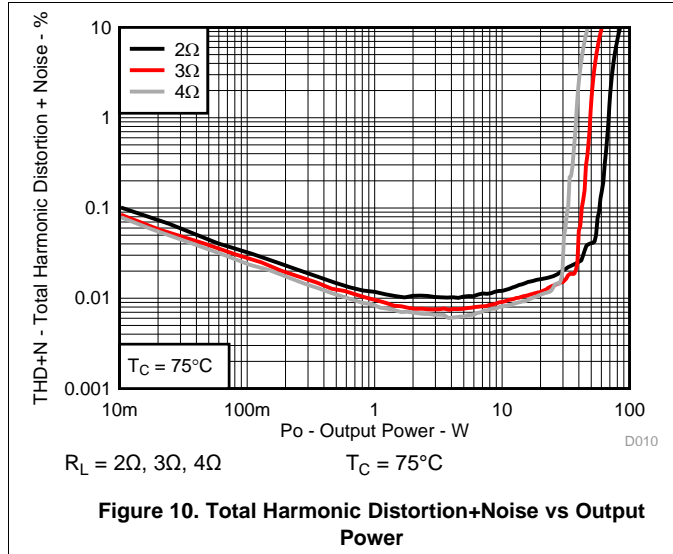

Figure 9. Noise Amplitude vs Frequency

### 7.10 Typical Characteristics, SE Configuration

All Measurements taken at audio frequency = 1 kHz, PVDD\_X = 36 V, GVDD\_X = 12 V, R<sub>L</sub> = 3 Ω, f<sub>S</sub> = 600 kHz, R<sub>OC</sub> = 22 kΩ, T<sub>C</sub> = 75°C, Output Filter: L<sub>DEM</sub> = 15 μH, C<sub>DEM</sub> = 680 nF, MODE = 11, AES17 + AUX-0025 measurement filters, unless otherwise noted.



### 7.11 Typical Characteristics, PBTL Configuration

All Measurements taken at audio frequency = 1kHz, PVDD\_X = 36V, GVDD\_X = 12V,  $R_L = 2\Omega$ ,  $f_S = 600\text{ kHz}$ ,  $R_{OC} = 22\text{k}\Omega$ ,  $T_C = 75^\circ\text{C}$ , Output Filter:  $L_{DEM} = 10\mu\text{H}$ ,  $C_{DEM} = 1\mu\text{F}$ , MODE = 10, AES17 + AUX-0025 measurement filters, unless otherwise noted.

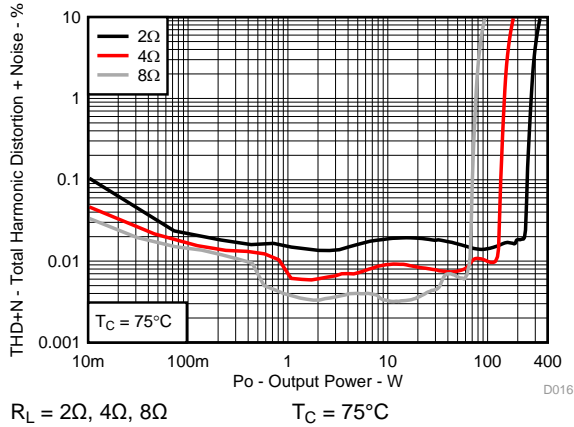

$R_L = 2\Omega, 4\Omega, 8\Omega$   $T_C = 75^\circ\text{C}$   
**Figure 16. Total Harmonic Distortion+Noise vs Output Power**

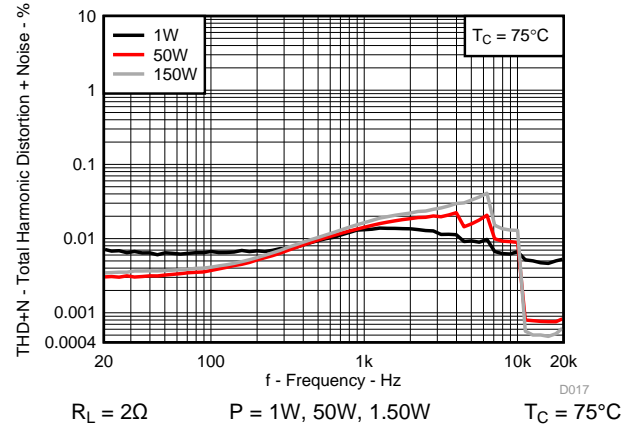

$R_L = 2\Omega$   $P = 1\text{W}, 50\text{W}, 150\text{W}$   $T_C = 75^\circ\text{C}$   
**Figure 17. Total Harmonic Distortion+Noise vs Frequency**

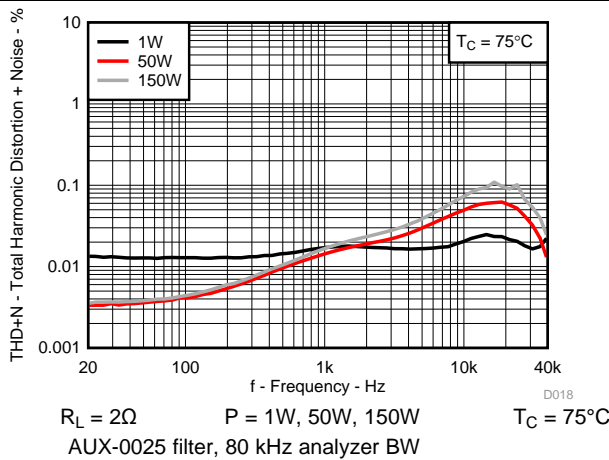

$R_L = 2\Omega$   $P = 1\text{W}, 50\text{W}, 150\text{W}$   $T_C = 75^\circ\text{C}$   
 AUX-0025 filter, 80 kHz analyzer BW  
**Figure 18. Total Harmonic Distortion+Noise vs Frequency**

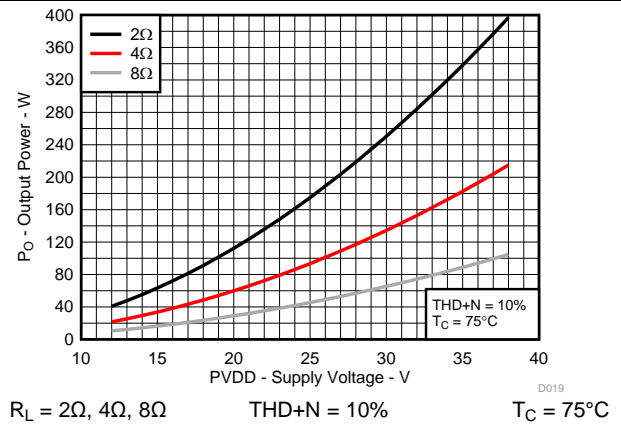

$R_L = 2\Omega, 4\Omega, 8\Omega$   $\text{THD+N} = 10\%$   $T_C = 75^\circ\text{C}$   
**Figure 19. Output Power vs Supply Voltage**

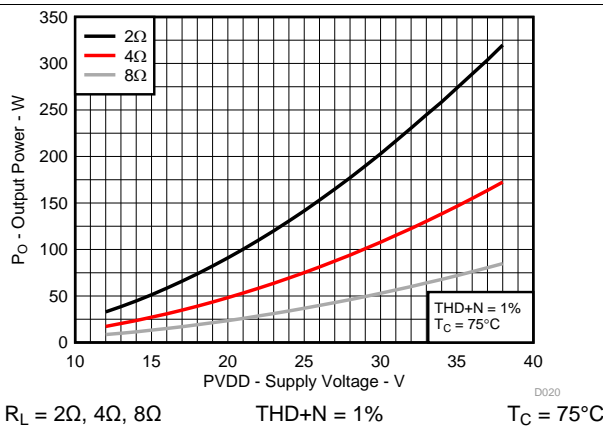

$R_L = 2\Omega, 4\Omega, 8\Omega$   $\text{THD+N} = 1\%$   $T_C = 75^\circ\text{C}$   
**Figure 20. Output Power vs Supply Voltage**

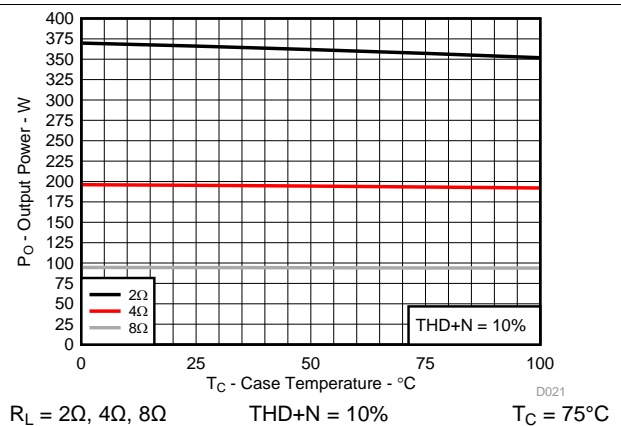

$R_L = 2\Omega, 4\Omega, 8\Omega$   $\text{THD+N} = 10\%$   $T_C = 75^\circ\text{C}$   
**Figure 21. Output Power vs Case Temperature**

## 8 Parameter Measurement Information

All parameters are measured according to the conditions described in the [Recommended Operating Conditions](#), [Typical Characteristics](#), [BTL Configuration](#), [Typical Characteristics](#), [SE Configuration](#) and [Typical Characteristics](#), [PBTL Configuration](#) sections.

Most audio analyzers will not give correct readings of Class-D amplifiers' performance due to their sensitivity to out of band noise present at the amplifier output. AES-17 + AUX-0025 pre-analyzer filters are recommended to use for Class-D amplifier measurements. In absence of such filters, a 30-kHz low-pass filter (10  $\Omega$  + 47 nF) can be used to reduce the out of band noise remaining on the amplifier outputs.

## 9 Detailed Description

### 9.1 Overview

To facilitate system design, the TPA3251 needs only a 12-V supply in addition to the (typical) 36-V power-stage supply. An internal voltage regulator provides suitable voltage levels for the digital and low-voltage analog circuitry, AVDD and DVDD. Additionally, all circuitry requiring a floating voltage supply, that is, the high-side gate drive, is accommodated by built-in bootstrap circuitry requiring only an external capacitor for each half-bridge.

The audio signal path including gate drive and output stage is designed as identical, independent half-bridges. For this reason, each half-bridge has separate bootstrap pins (BST\_X). Power-stage supply pins (PVDD\_X) and gate drive supply pins (GVDD\_X) are separate for each full bridge. Although supplied from the same 12-V source, separating to GVDD\_AB, GVDD\_CD, and VDD on the printed-circuit board (PCB) by RC filters (see application diagram for details) is recommended. These RC filters provide the recommended high-frequency isolation. Special attention should be paid to placing all decoupling capacitors as close to their associated pins as possible. In general, the physical loop with the power supply pins, decoupling capacitors and GND return path to the device pins must be kept as short as possible and with as little area as possible to minimize induction (see reference board documentation for additional information).

For a properly functioning bootstrap circuit, a small ceramic capacitor must be connected from each bootstrap pin (BST\_X) to the power-stage output pin (OUT\_X). When the power-stage output is low, the bootstrap capacitor is charged through an internal diode connected between the gate-drive power-supply pin (GVDD\_X) and the bootstrap pins. When the power-stage output is high, the bootstrap capacitor potential is shifted above the output potential and thus provides a suitable voltage supply for the high-side gate driver. It is recommended to use 33-nF ceramic capacitors, size 0603 or 0805, for the bootstrap supply. These 33nF capacitors ensure sufficient energy storage, even during minimal PWM duty cycles, to keep the high-side power stage FET (LDMOS) fully turned on during the remaining part of the PWM cycle.

Special attention should be paid to the power-stage power supply; this includes component selection, PCB placement, and routing. As indicated, each full-bridge has independent power-stage supply pins (PVDD\_X). For optimal electrical performance, EMI compliance, and system reliability, it is important that each PVDD\_X node is decoupled with 1- $\mu$ F ceramic capacitor placed as close as possible to the supply pins. It is recommended to follow the PCB layout of the TPA3251 reference design. For additional information on recommended power supply and required components, see the application diagrams in this data sheet.

The 12-V supply should be from a low-noise, low-output-impedance voltage regulator. Likewise, the 36-V power-stage supply is assumed to have low output impedance and low noise. The power-supply sequence is not critical as facilitated by the internal power-on-reset circuit, but it is recommended to release **RESET** after the power supply is settled for minimum turn on audible artefacts. Moreover, the TPA3251 is fully protected against erroneous power-stage turn on due to parasitic gate charging. Thus, voltage-supply ramp rates (dV/dt) are non-critical within the specified range (see the [Recommended Operating Conditions](#) table of this data sheet).

## 9.2 Functional Block Diagrams

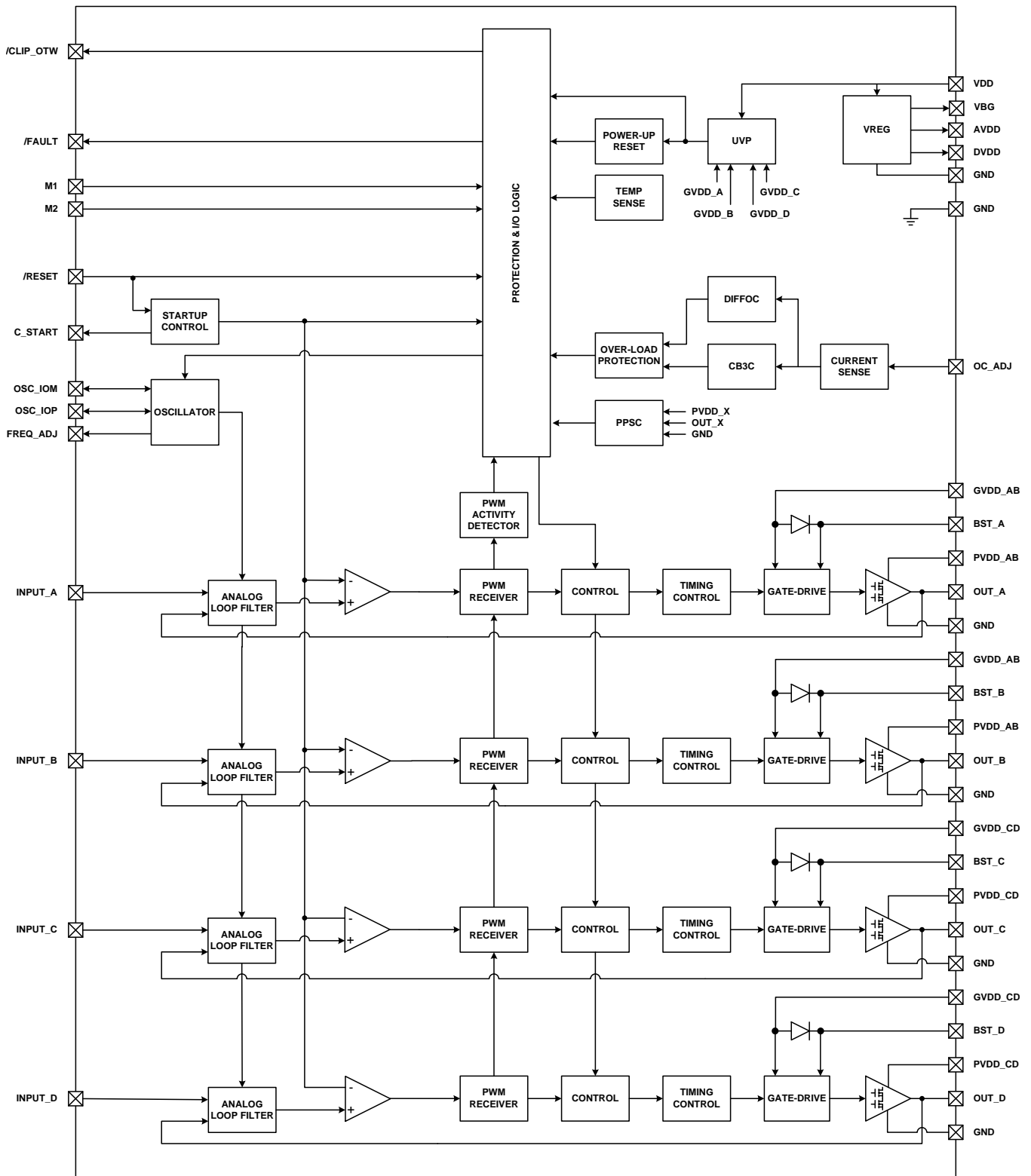

FunctionalBlockDiagram.vsd

Functional Block Diagrams (continued)

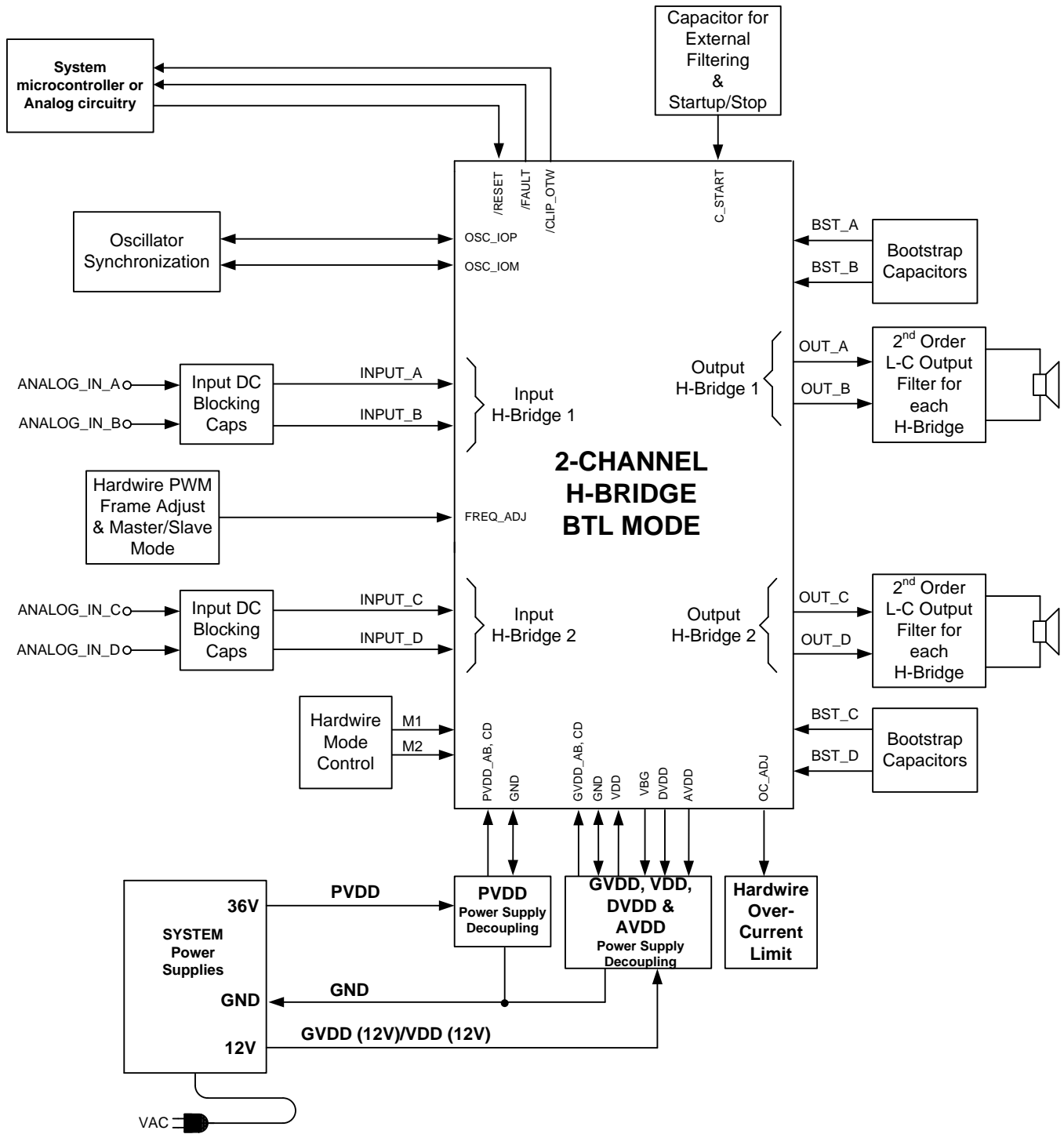

\*NOTE1: Logic AND in or outside microcontroller

Figure 22. System Block Diagram

## 9.3 Feature Description

### 9.3.1 Error Reporting

The  $\overline{\text{FAULT}}$ , and  $\overline{\text{CLIP\_OTW}}$ , pins are active-low, open-drain outputs. The function is for protection-mode signaling to a system-control device.

Any fault resulting in device shutdown is signaled by the  $\overline{\text{FAULT}}$  pin going low. Also,  $\overline{\text{CLIP\_OTW}}$  goes low when the device junction temperature exceeds 125°C (see [Table 2](#)).

**Table 2. Error Reporting**

| $\overline{\text{FAULT}}$ | $\overline{\text{CLIP\_OTW}}$ | DESCRIPTION  |
|---------------------------|-------------------------------|--|
| 0                         | 0                             | Overtemperature (OTE) or overload (OLP) or undervoltage (UVP) Junction temperature higher than 125°C (overtemperature warning) |
| 0                         | 0                             | Overload (OLP) or undervoltage (UVP). Junction temperature higher than 125°C (overtemperature warning)                         |
| 0                         | 1                             | Overload (OLP) or undervoltage (UVP). Junction temperature lower than 125°C  |
| 1                         | 0                             | Junction temperature higher than 125°C (overtemperature warning)   |
| 1                         | 1                             | Junction temperature lower than 125°C and no OLP or UVP faults (normal operation)  |

Note that asserting either  $\overline{\text{RESET}}$  low forces the  $\overline{\text{FAULT}}$  signal high, independent of faults being present. TI recommends monitoring the  $\overline{\text{CLIP\_OTW}}$  signal using the system microcontroller and responding to an overtemperature warning signal by, that is, turning down the volume to prevent further heating of the device resulting in device shutdown (OTE).

To reduce external component count, an internal pullup resistor to 3.3 V is provided on both  $\overline{\text{FAULT}}$  and  $\overline{\text{CLIP\_OTW}}$  outputs.

## 9.4 Device Protection System

The TPA3251 contains advanced protection circuitry carefully designed to facilitate system integration and ease of use, as well as to safeguard the device from permanent failure due to a wide range of fault conditions such as short circuits, overload, overtemperature, and undervoltage. The TPA3251 responds to a fault by immediately setting the power stage in a high-impedance (Hi-Z) state and asserting the  $\overline{\text{FAULT}}$  pin low. In situations other than overload and overtemperature error (OTE), the device automatically recovers when the fault condition has been removed, that is, the supply voltage has increased.

The device will function on errors, as shown in [Table 3](#).

**Table 3. Device Protection**

| BTL            | MODE      | PBTL           | MODE      | SE             | MODE      |
|----------------|-----------|----------------|-----------|----------------|-----------|
| LOCAL ERROR IN | TURNS OFF | LOCAL ERROR IN | TURNS OFF | LOCAL ERROR IN | TURNS OFF |
| A              | A+B       | A              | A+B+C+D   | A              | A+B       |
| B              |           | B              |           | B              |           |
| C              | C+D       | C              |           | C              | C+D       |
| D              |           | D              |           | D              |           |

Bootstrap UVP does not shutdown according to the table, it shuts down the respective halfbridge (non-latching, does not assert  $\overline{\text{FAULT}}$ ).

### 9.4.1 Overload and Short Circuit Current Protection

TPA3251 has fast reacting current sensors with a programmable trip threshold (OC threshold) on all high-side and low-side FETs. To prevent output current to increase beyond the programmed threshold, TPA3251 has the option of either limiting the output current for each switching cycle (Cycle By Cycle Current Control, CB3C) or to perform an immediate shutdown of the output in case of excess output current (Latching Shutdown). CB3C prevents premature shutdown due to high output current transients caused by high level music transients and a drop of real speaker's load impedance, and allows the output current to be limited to a maximum programmed

level. If the maximum output current persists, i.e. the power stage being overloaded with too low load impedance, the device will shut down the affected output channel and the affected output is put in a high-impedance (Hi- Z) state until a RESET cycle is initiated. CB3C works individually for each half bridge output. If an over current event is triggered, CB3C performs a state flip of the half bridge output that is cleared upon beginning of next PWM frame.

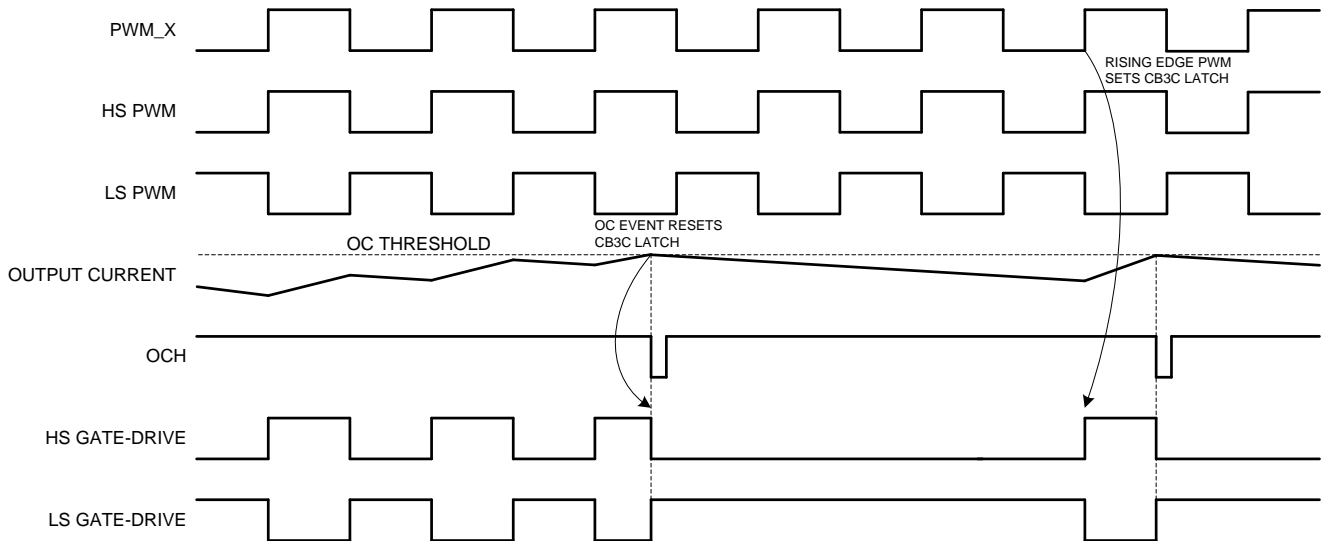

Figure 23. CB3C Timing Example

During CB3C an over load counter increments for each over current event and decrease for each non-over current PWM cycle. This allows full amplitude transients into a low speaker impedance without a shutdown protection action. In the event of a short circuit condition, the over current protection limits the output current by the CB3C operation and eventually shut down the affected output if the overload counter reaches its maximum value. If a latched OC operation is required such that the device shuts down the affected output immediately upon first detected over current event, this protection mode should be selected. The over current threshold and mode (CB3C or Latched OC) is programmed by the OC\_ADJ resistor value. The OC\_ADJ resistor needs to be within its intentional value range for either CB3C operation or Latched OC operation.

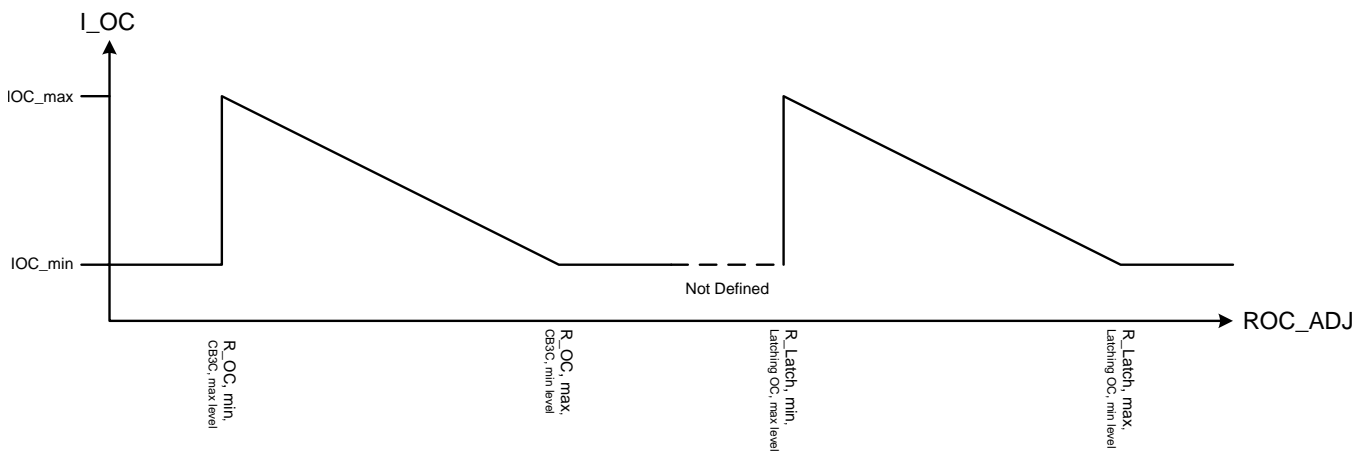

Figure 24. OC Threshold versus OC\_ADJ Resistor Value Example

OC\_ADJ values outside specified value range for either CB3C or latched OC operation will result in minimum OC threshold.

**Table 4. Device Protection**

| OC_ADJ Resistor Value | Protection Mode | OC Threshold |
|-----------------------|-----------------|--------------|
| 22k $\Omega$          | CB3C            | 16.3A        |
| 24k $\Omega$          | CB3C            | 15.1A        |
| 27k $\Omega$          | CB3C            | 13.5A        |
| 30k $\Omega$          | CB3C            | 12.3A        |
| 47k $\Omega$          | Latched OC      | 16.3A        |
| 51k $\Omega$          | Latched OC      | 15.1A        |
| 56k $\Omega$          | Latched OC      | 13.5A        |
| 64k $\Omega$          | Latched OC      | 12.3A        |

#### 9.4.2 DC Speaker Protection

The output DC protection scheme protects a connected speaker from excess DC current caused by a speaker wire accidentally shorted to chassis ground. Such a short circuit results in a DC voltage of  $PVDD/2$  across the speaker, which potentially can result in destructive current levels. The output DC protection detects any unbalance of the output and input current of a BTL output, and in the event of the unbalance exceeding a programmed threshold, the overload counter increments until its maximum value and the affected output channel is shut down. DC Speaker Protection is disabled in PBTL and SE mode operation.

#### 9.4.3 Pin-to-Pin Short Circuit Protection (PPSC)

The PPSC detection system protects the device from permanent damage in the case that a power output pin (OUT\_X) is shorted to GND\_X or PVDD\_X. For comparison, the OC protection system detects an overcurrent after the demodulation filter where PPSC detects shorts directly at the pin before the filter. PPSC detection is performed at startup i.e. when VDD is supplied, consequently a short to either GND\_X or PVDD\_X after system startup does not activate the PPSC detection system. When PPSC detection is activated by a short on the output, all half bridges are kept in a Hi-Z state until the short is removed; the device then continues the startup sequence and starts switching. The detection is controlled globally by a two step sequence. The first step ensures that there are no shorts from OUT\_X to GND\_X, the second step tests that there are no shorts from OUT\_X to PVDD\_X. The total duration of this process is roughly proportional to the capacitance of the output LC filter. The typical duration is  $< 15\text{ms}/\mu\text{F}$ . While the PPSC detection is in progress, FAULT is kept low, and the device will not react to changes applied to the RESET pin. If no shorts are present the PPSC detection passes, and FAULT is released. A device reset will not start a new PPSC detection. PPSC detection is enabled in BTL and PBTL output configurations, the detection is not performed in SE mode. To make sure not to trip the PPSC detection system it is recommended not to insert a resistive load to GND\_X or PVDD\_X.

#### 9.4.4 Overtemperature Protection OTW and OTE

TPA3251 has a two-level temperature-protection system that asserts an active-low warning signal ( $\overline{\text{CLIP\_OTW}}$ ) when the device junction temperature exceeds 125°C (typical) and, if the device junction temperature exceeds 155°C (typical), the device is put into thermal shutdown, resulting in all half-bridge outputs being set in the high-impedance (Hi-Z) state and FAULT being asserted low. OTE is latched in this case. To clear the OTE latch, RESET must be asserted. Thereafter, the device resumes normal operation.

#### 9.4.5 Undervoltage Protection (UVP) and Power-on Reset (POR)

The UVP and POR circuits of the TPA3251 fully protect the device in any power-up/down and brownout situation. While powering up, the POR circuit resets the overload circuit (OLP) and ensures that all circuits are fully operational when the GVDD\_X and VDD supply voltages reach stated in the [Electrical Characteristics](#) table. Although GVDD\_X and VDD are independently monitored, a supply voltage drop below the UVP threshold on any VDD or GVDD\_X pin results in all half-bridge outputs immediately being set in the high-impedance (Hi-Z) state and FAULT being asserted low. The device automatically resumes operation when all supply voltages have increased above the UVP threshold.

### 9.4.6 Fault Handling

If a fault situation occurs while in operation, the device acts accordingly to the fault being a global or a channel fault. A global fault is a chip-wide fault situation and causes all PWM activity of the device to be shut down, and will assert FAULT low. A global fault is a latching fault and clearing FAULT and restart operation requires resetting the device by toggling RESET. Toggling RESET should never be allowed with excessive system temperature, so it is advised to monitor RESET by a system microcontroller and only allow releasing RESET (RESET high) if the OTW signal is cleared (high). A channel fault results in shutdown of the PWM activity of the affected channel(s). Note that asserting RESET low forces the FAULT signal high, independent of faults being present. TI recommends monitoring the OTW signal using the system micro controller and responding to an over temperature warning signal by, that is, turning down the volume to prevent further heating of the device resulting in device shutdown (OTE).

**Table 5. Error Reporting**

| Fault/Event                                       | Fault/Event Description          | Global or Channel     | Reporting Method              | Latched/Self Clearing | Action needed to Clear                          | Output FETs                        |
|---|----------------------------------|-----------------------|-------------------------------|-----------------------|---|------------------------------------|
| PVDD_X UVP  | Voltage Fault                    | Global                | $\overline{\text{FAULT}}$ pin | Self Clearing         | Increase affected supply voltage                | HI-Z                               |
| VDD UVP   |                                  |                       |                               |                       |   |                                    |
| AVDD UVP  |                                  |                       |                               |                       |   |                                    |
| POR (DVDD UVP)                                    | Power On Reset                   | Global                | $\overline{\text{FAULT}}$ pin | Self Clearing         | Allow DVDD to rise                              | HI-Z                               |
| BST_X UVP   | Voltage Fault                    | Channel (Half Bridge) | None                          | Self Clearing         | Allow BST cap to recharge (lowside ON, VDD 12V) | HighSide off                       |
| OTW   | Thermal Warning                  | Global                | $\overline{\text{OTW}}$ pin   | Self Clearing         | Cool below OTW threshold                        | Normal operation                   |
| OTE   | Thermal Shutdown                 | Global                | $\overline{\text{FAULT}}$ pin | Latched               | Toggle $\overline{\text{RESET}}$                | HI-Z                               |
| OLP (CB3C>1.7ms)                                  | OC Shutdown                      | Channel               | $\overline{\text{FAULT}}$ pin | Latched               | Toggle $\overline{\text{RESET}}$                | HI-Z                               |
| Latched OC (47k $\Omega$ <ROC_ADJ<68 k $\Omega$ ) | OC Shutdown                      | Channel               | $\overline{\text{FAULT}}$ pin | Latched               | Toggle $\overline{\text{RESET}}$                | HI-Z                               |
| CB3C (22k $\Omega$ <ROC_ADJ<30 k $\Omega$ )       | OC Limiting                      | Channel               | None                          | Self Clearing         | Reduce signal level or remove short             | Flip state, cycle by cycle at fs/3 |
| Stuck at Fault <sup>(1)</sup>                     | No OSC_IO activity in Slave Mode | Global                | None                          | Self Clearing         | Resume OSC_IO activity                          | HI-Z                               |

(1) Stuck at Fault occurs when input OSC\_IO input signal frequency drops below minimum frequency given in the [Electrical Characteristics](#) table of this data sheet.

### 9.4.7 Device Reset

Asserting  $\overline{\text{RESET}}$  low initiates the device ramp down. The output FETs go into a Hi-Z state after the ramp down is complete. Output pull downs are active both in SE mode and BTL mode with  $\overline{\text{RESET}}$  low.

In BTL modes, to accommodate bootstrap charging prior to switching start, asserting the reset input low enables weak pulldown of the half-bridge outputs.

Asserting reset input low removes any fault information to be signaled on the  $\overline{\text{FAULT}}$  output, that is,  $\overline{\text{FAULT}}$  is forced high. A rising-edge transition on reset input allows the device to resume operation after an overload fault. To ensure thermal reliability, the rising edge of reset must occur no sooner than 4 ms after the falling edge of  $\overline{\text{FAULT}}$ .

## 10 Application and Implementation

### NOTE

Information in the following applications sections is not part of the TI component specification, and TI does not warrant its accuracy or completeness. TI's customers are responsible for determining suitability of components for their purposes. Customers should validate and test their design implementation to confirm system functionality.

### 10.1 Application Information

TPA3251 can be configured either in stereo BTL mode, 4 channel SE mode, mono PBTL mode, or in 2.1 mixed 1x BTL + 2x SE mode depending on output power conditions and system design.

### 10.2 Typical Applications

#### 10.2.1 Stereo BTL Application

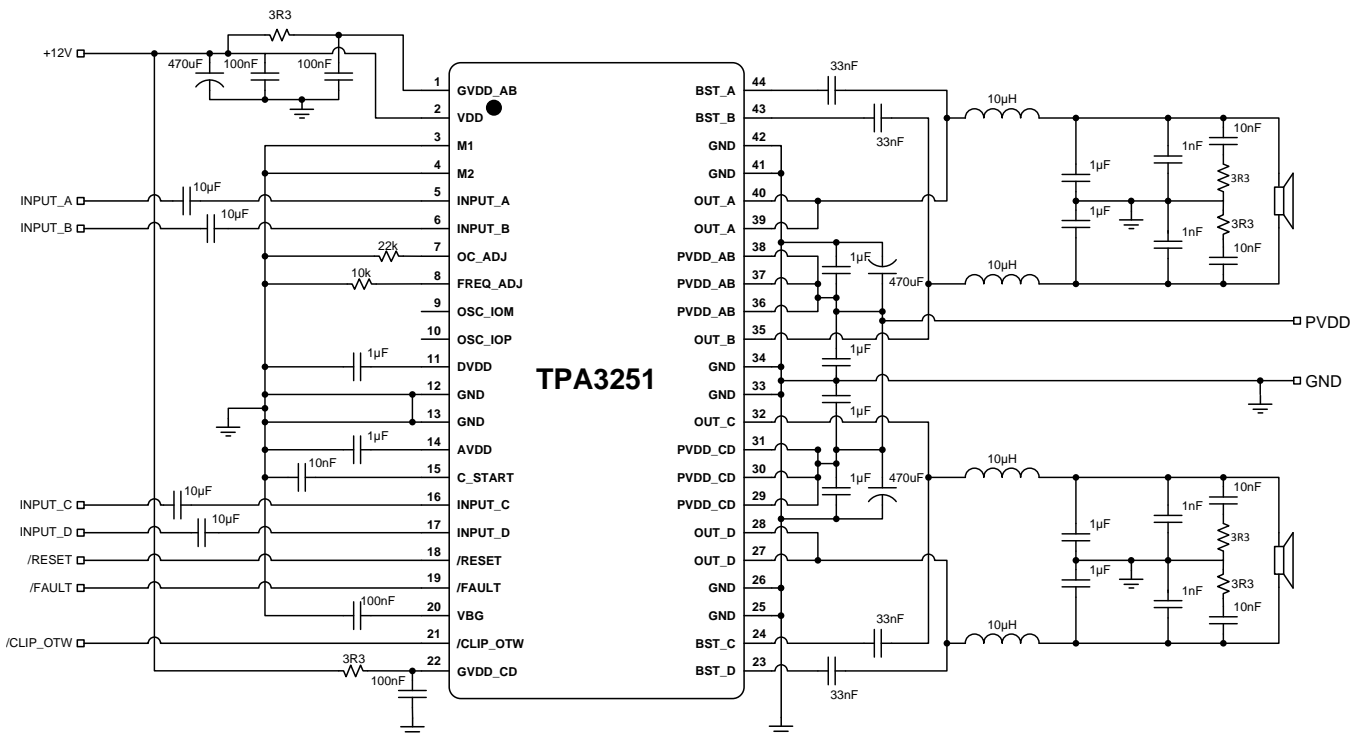

Figure 25. Typical Differential Input BTL Application

## Typical Applications (continued)

### 10.2.1.1 Design Requirements

For this design example, use the parameters in [Table 6](#).

**Table 6. Design Requirements, BTL Application**

| DESIGN PARAMETER           | EXAMPLE   |
|----------------------------|---|
| Low Power (Pull-up) Supply | 3.3 V   |
| Mid Power Supply 12 V      | 12 V  |
| High Power Supply          | 12 - 36 V   |
| Mode Selection             | M2 = L  |
|                            | M1 = L  |
| Analog Inputs              | INPUT_A = ±3.9 V (peak, max)                      |
|                            | INPUT_B = ± 3.9V (peak, max)                      |
|                            | INPUT_C = ±3.9 V (peak, max)                      |
|                            | INPUT_D = ±3.9 V (peak, max)                      |
| Output Filters             | Inductor-Capacitor Low Pass Filter (10 µH + 1 µF) |
| Speaker Impedance          | 3-8 Ω   |

### 10.2.1.2 Detailed Design Procedures

A rising-edge transition on reset input allows the device to execute the startup sequence and starts switching.

The CLIP signal is indicating that the output is approaching clipping. The signal can be used to either an audio volume decrease or intelligent power supply nominally operating at a low rail adjusting to a higher supply rail.

The device is inverting the audio signal from input to output.

The DVDD and AVDD pins are not recommended to be used as a voltage sources for external circuitry.

#### 10.2.1.2.1 Decoupling Capacitor Recommendations

In order to design an amplifier that has robust performance, passes regulatory requirements, and exhibits good audio performance, good quality decoupling capacitors should be used. In practice, X7R should be used in this application.

The voltage of the decoupling capacitors should be selected in accordance with good design practices. Temperature, ripple current, and voltage overshoot must be considered. This fact is particularly true in the selection of the 1µF that is placed on the power supply to each full-bridge. It must withstand the voltage overshoot of the PWM switching, the heat generated by the amplifier during high power output, and the ripple current created by high power output. A minimum voltage rating of 50 V is required for use with a 36V power supply.

#### 10.2.1.2.2 PVDD Capacitor Recommendation

The large capacitors used in conjunction with each full-bridge, are referred to as the PVDD Capacitors. These capacitors should be selected for proper voltage margin and adequate capacitance to support the power requirements. In practice, with a well designed system power supply, 1000 µF, 50 V supports most applications. The PVDD capacitors should be low ESR type because they are used in a circuit associated with high-speed switching.

#### 10.2.1.2.3 PCB Material Recommendation

FR-4 Glass Epoxy material with 2 oz. (70 µm) copper is recommended for use with the TPA3251. The use of this material can provide for higher power output, improved thermal performance, and better EMI margin (due to lower PCB trace inductance).

#### 10.2.1.2.4 Oscillator

The oscillator frequency can be trimmed by external control of the `FREQ_ADJ` pin.

To reduce interference problems while using radio receiver tuned within the AM band, the switching frequency can be changed from nominal to lower values. These values should be chosen such that the nominal and the lower value switching frequencies together results in the fewest cases of interference throughout the AM band. The oscillator frequency can be selected by the value of the `FREQ_ADJ` resistor connected to GND in master mode according to the description in the Recommended Operating Conditions table.

For slave mode operation, turn off the oscillator by pulling the `FREQ_ADJ` pin to DVDD. This configures the `OSC_I/O` pins as inputs to be slaved from an external differential clock. In a master/slave system inter channel delay is automatically setup between the switching of the audio channels, which can be illustrated by no idle channels switching at the same time. This will not influence the audio output, but only the switch timing to minimize noise coupling between audio channels through the power supply to optimize audio performance and to get better operating conditions for the power supply. The inter channel delay will be setup for a slave device depending on the polarity of the `OSC_I/O` connection such that a slave mode 1 is selected by connecting the master device `OSC_I/O` to the slave 1 device `OSC_I/O` with same polarity (+ to + and - to -), and slave mode 2 is selected with the inverse polarity (+ to - and - to +).

### 10.2.2 Application Curves

Relevant performance plots for TPA3251 in BTL configuration are shown in [Typical Characteristics](#), [BTL Configuration](#)

**Table 7. Relevant Performance Plots, BTL Configuration**

| PLOT TITLE  | FIGURE NUMBER            |
|---|--------------------------|
| Total Harmonic Distortion+Noise vs Frequency                    | <a href="#">Figure 1</a> |
| Total Harmonic Distortion+Noise vs Frequency, 80kHz analyzer BW | <a href="#">Figure 2</a> |
| Total Harmonic Distortion + Noise vs Output Power               | <a href="#">Figure 3</a> |
| Output Power vs Supply Voltage, 10% THD+N                       | <a href="#">Figure 4</a> |
| Output Power vs Supply Voltage, 10% THD+N                       | <a href="#">Figure 6</a> |
| System Efficiency vs Output Power                               | <a href="#">Figure 6</a> |
| System Power Loss vs Output Power                               | <a href="#">Figure 7</a> |
| Output Power vs Case Temperature                                | <a href="#">Figure 8</a> |
| Noise Amplitude vs Frequency                                    | <a href="#">Figure 9</a> |

### 10.2.3 Typical Application, Single Ended (1N) SE

TPA3251 can be configured either in stereo BTL mode, 4 channel SE mode, mono PBTL mode, or in 2.1 mixed 1x BTL + 2x SE mode depending on output power conditions and system design.

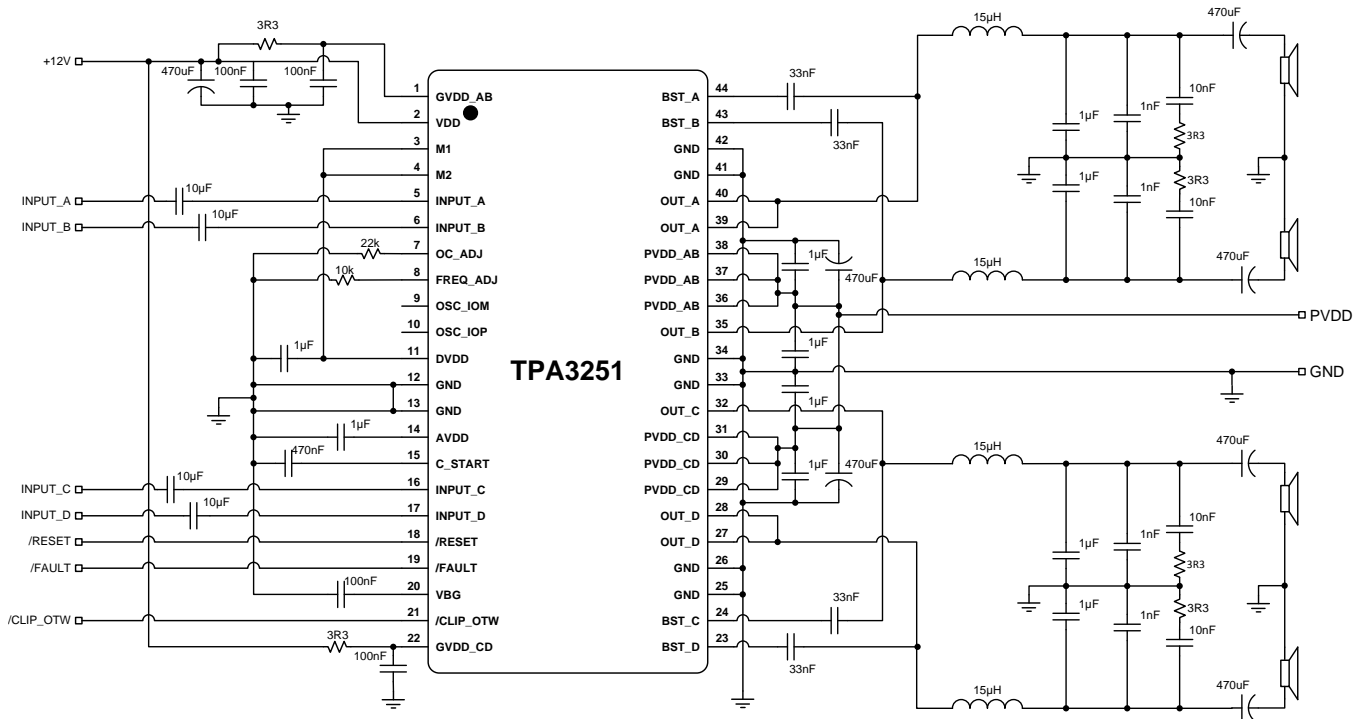

Figure 26. Typical Single Ended (1N) SE Application

#### 10.2.3.1 Design Requirements

Refer to [Stereo BTL Application](#) for the Design Requirements.

Table 8. Design Requirements, SE Application

| DESIGN PARAMETER           | EXAMPLE   |
|----------------------------|---|
| Low Power (Pull-up) Supply | 3.3 V   |
| Mid Power Supply 1 2V      | 12 V  |
| High Power Supply          | 12 - 36 V   |
| Mode Selection             | M2 = H  |
|                            | M1 = H  |
| Analog Inputs              | INPUT_A = ±3.9 V (peak, max)                        |
|                            | INPUT_B = ±3.9 V (peak, max)                        |
|                            | INPUT_C = ±3.9 V (peak, max)                        |
|                            | INPUT_D = ±3.9 V (peak, max)                        |
| Output Filters             | Inductor-Capacitor Low Pass Filter (15 µH + 680 nF) |
| Speaker Impedance          | 2 - 8 Ω   |

#### 10.2.3.2 Detailed Design Procedures

Refer to [Stereo BTL Application](#) for the Detailed Design Procedures.

### 10.2.3.3 Application Curves

Relevant performance plots for TPA3251 in PBTL configuration are shown in [Typical Characteristics](#), [SE Configuration](#)

**Table 9. Relevant Performance Plots, SE Configuration**

| PLOT TITLE  | FIGURE NUMBER             |
|---|---------------------------|
| Total Harmonic Distortion+Noise vs Output Power                 | <a href="#">Figure 10</a> |
| Total Harmonic Distortion+Noise vs Frequency                    | <a href="#">Figure 11</a> |
| Total Harmonic Distortion+Noise vs Frequency, 80kHz analyzer BW | <a href="#">Figure 12</a> |
| Output Power vs Supply Voltage, 10% THD+N                       | <a href="#">Figure 13</a> |
| Output Power vs Supply Voltage, 1% THD+N                        | <a href="#">Figure 14</a> |
| Output Power vs Case Temperature                                | <a href="#">Figure 15</a> |

### 10.2.4 Typical Application, Differential (2N) PBTL

TPA3251 can be configured either in stereo BTL mode, 4 channel SE mode, mono PBTL mode, or in 2.1 mixed 1x BTL + 2x SE mode depending on output power conditions and system design.

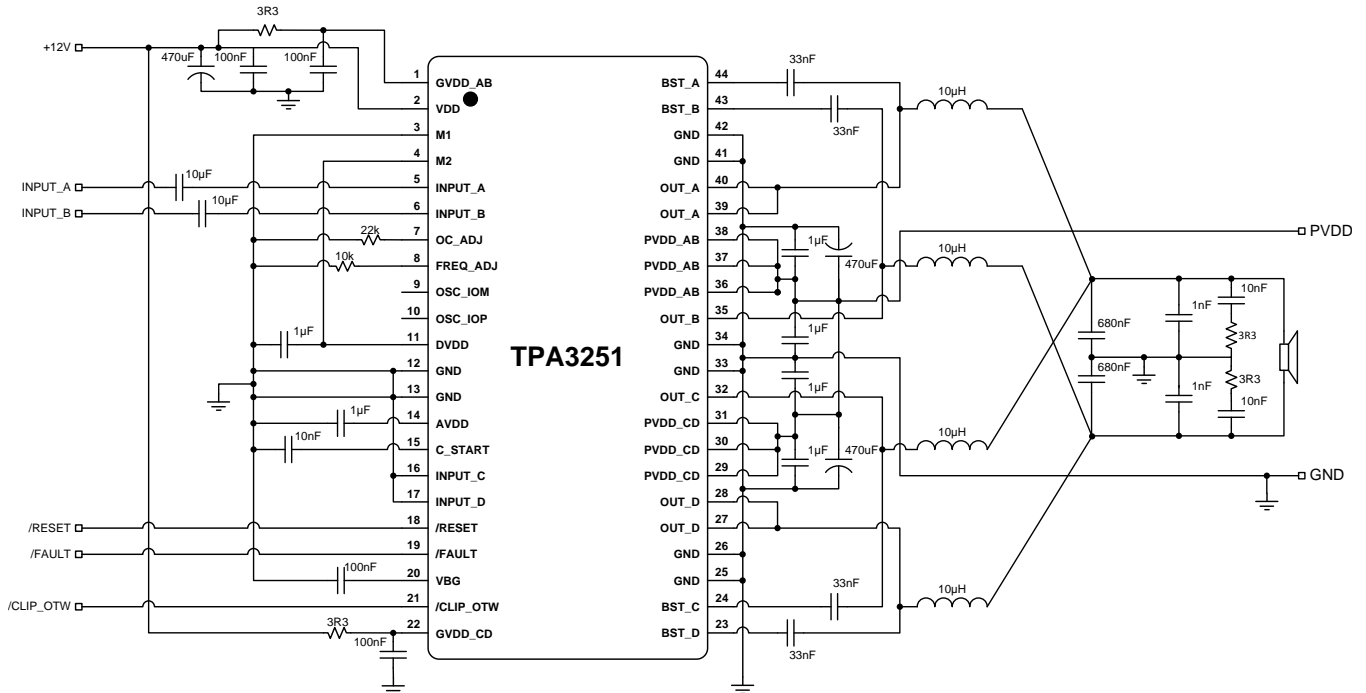

Figure 27. Typical Differential (2N) PBTL Application

#### 10.2.4.1 Design Requirements

Refer to [Stereo BTL Application](#) for the Design Requirements.

Table 10. Design Requirements, PBTL Application

| DESIGN PARAMETER           | EXAMPLE   |
|----------------------------|---|
| Low Power (Pull-up) Supply | 3.3 V   |
| Mid Power Supply 12 V      | 12 V  |
| High Power Supply          | 12 - 36 V   |
| Mode Selection             | M2 = H  |
|                            | M1 = L  |
| Analog Inputs              | INPUT_A = ±3.9V (peak, max)                       |
|                            | INPUT_B = ±3.9V (peak, max)                       |
|                            | INPUT_C = Grounded                                |
|                            | INPUT_D = Grounded                                |
| Output Filters             | Inductor-Capacitor Low Pass Filter (10 μH + 1 μF) |
| Speaker Impedance          | 2 - 4 Ω   |

#### 10.2.4.2 Detailed Design Procedures

Refer to [Stereo BTL Application](#) for the Detailed Design Procedures.

### 10.2.4.3 Application Curves

Relevant performance plots for TPA3251 in PBTL configuration are shown in [Typical Characteristics, PBTL Configuration](#)

**Table 11. Relevant Performance Plots, PBTL Configuration**

| PLOT TITLE  | FIGURE NUMBER             |
|---|---------------------------|
| Total Harmonic Distortion+Noise vs Output Power                 | <a href="#">Figure 16</a> |
| Total Harmonic Distortion+Noise vs Frequency                    | <a href="#">Figure 17</a> |
| Total Harmonic Distortion+Noise vs Frequency, 80kHz analyzer BW | <a href="#">Figure 18</a> |
| Output Power vs Supply Voltage, 10% THD+N                       | <a href="#">Figure 19</a> |
| Output Power vs Supply Voltage, 1% THD+N                        | <a href="#">Figure 20</a> |
| Output Power vs Case Temperature                                | <a href="#">Figure 21</a> |

## 11 Power Supply Recommendations

### 11.1 Power Supplies

The TPA3251 device requires two external power supplies for proper operation. A high-voltage supply called PVDD is required to power the output stage of the speaker amplifier and its associated circuitry. Additionally, one mid-voltage power supply for GVDD\_X and VDD is required to power the gate-drive and other internal digital and analog portions of the device. The allowable voltage range for both the PVDD and the GVDD\_X/VDD supplies are listed in the [Recommended Operating Conditions](#) table. Ensure both the PVDD and the GVDD\_X/VDD supplies can deliver more current than listed in the [Electrical Characteristics](#) table.

#### 11.1.1 VDD Supply

The VDD supply required from the system is used to power several portions of the device. It provides power to internal regulators DVDD and AVDD that are used to power digital and analog sections of the device, respectively. Proper connection, routing, and decoupling techniques are highlighted in the TPA3251 device EVM User's Guide [SLVUAG8](#) (as well as the [Application Information](#) section and [Layout Examples](#) section) and must be followed as closely as possible for proper operation and performance. Deviation from the guidance offered in the TPA3251 device EVM User's Guide, which followed the same techniques as those shown in the [Application Information](#) section, may result in reduced performance, errant functionality, or even damage to the TPA3251 device. Some portions of the device also require a separate power supply which is a lower voltage than the VDD supply. To simplify the power supply requirements for the system, the TPA3251 device includes integrated low-dropout (LDO) linear regulators to create these supplies. These linear regulators are internally connected to the VDD supply and their outputs are presented on AVDD and DVDD pins, providing a connection point for an external bypass capacitors. It is important to note that the linear regulators integrated in the device have only been designed to support the current requirements of the internal circuitry, and should not be used to power any additional external circuitry. Additional loading on these pins could cause the voltage to sag and increase noise injection, which negatively affects the performance and operation of the device.

#### 11.1.2 GVDD\_X Supply

The GVDD\_X supply required from the system is used to power the gate-drives for the output H-bridges. Proper connection, routing, and decoupling techniques are highlighted in the TPA3251 device EVM User's Guide [SLVUAG8](#) (as well as the [Application Information](#) section and [Layout Examples](#) section) and must be followed as closely as possible for proper operation and performance. Deviation from the guidance offered in the TPA3251 device EVM User's Guide, which followed the same techniques as those shown in the [Application Information](#) section, may result in reduced performance, errant functionality, or even damage to the TPA3251 device.

## Power Supplies (continued)

### 11.1.3 PVDD Supply

The output stage of the speaker amplifier drives the load using the PVDD supply. This is the power supply which provides the drive current to the load during playback. Proper connection, routing, and decoupling techniques are highlighted in the TPA3251 device EVM User's Guide SLVUAG8 (as well as the [Application Information](#) section and [Layout Examples](#) section) and must be followed as closely as possible for proper operation and performance. Due the high-voltage switching of the output stage, it is particularly important to properly decouple the output power stages in the manner described in the TPA3251 device EVM User's Guide [SLVUAG8](#). The lack of proper decoupling, like that shown in the EVM User's Guide, can results in voltage spikes which can damage the device, or cause poor audio performance and device shutdown faults.

### 11.2 Powering Up

The TPA3251 does not require a power-up sequence, but it is recommended to hold  $\overline{\text{RESET}}$  low minimum 400ms after PVDD supply voltage is turned ON. The outputs of the H-bridges remain in a high-impedance state until the gate-drive supply voltage (GVDD\_X) and VDD voltage are above the undervoltage protection (UVP) voltage threshold (see the [Electrical Characteristics](#) table of this data sheet). This allows an internal circuit to charge the external bootstrap capacitors by enabling a weak pulldown of the half-bridge output as well as initiating a controlled ramp up sequence of the output voltage.

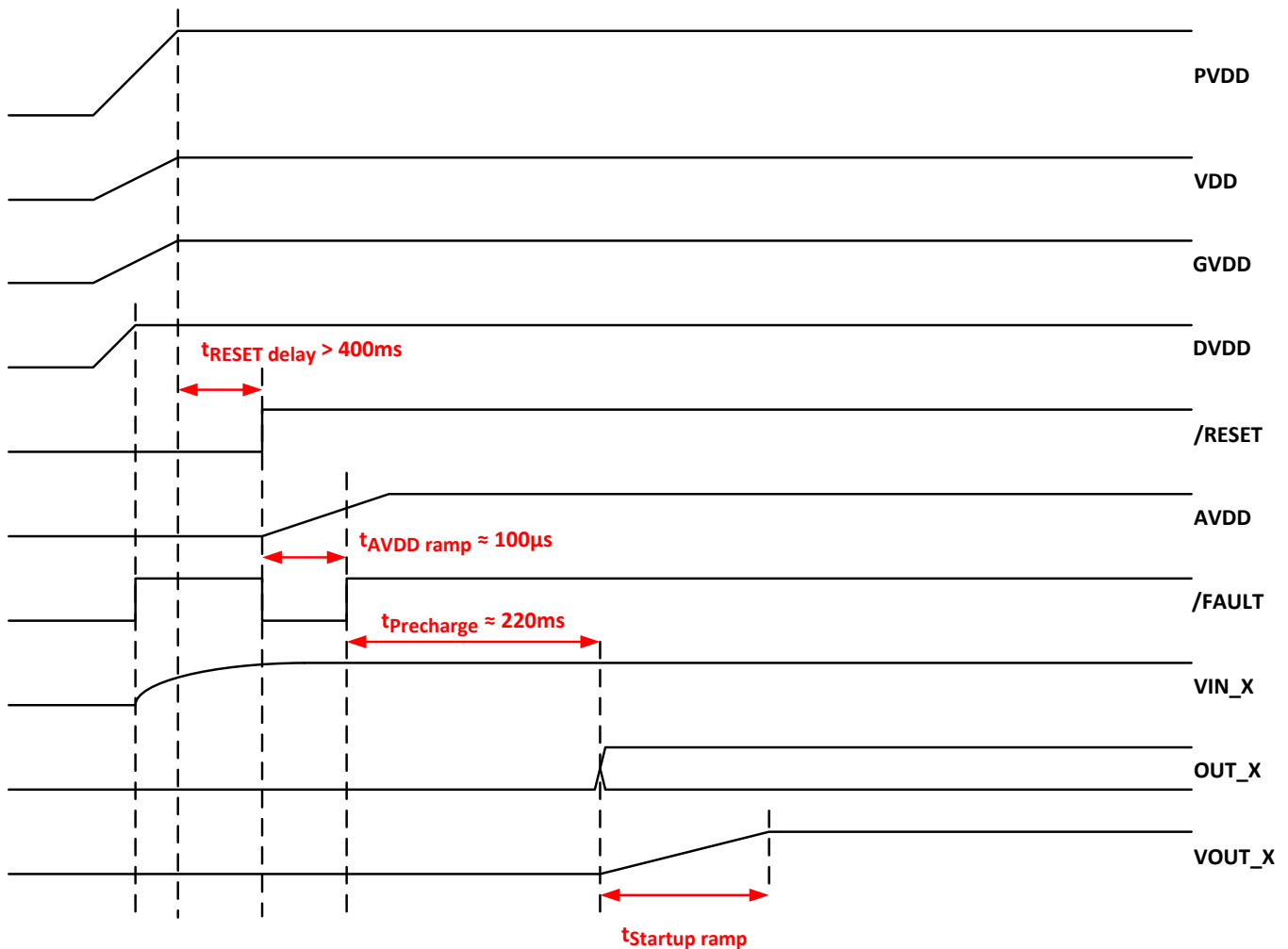

**Figure 28. Startup Timing**

## Powering Up (continued)

When  $\overline{\text{RESET}}$  is released to turn on TPA3251,  $\overline{\text{FAULT}}$  signal will turn low and AVDD voltage regulator will be enabled.  $\overline{\text{FAULT}}$  will stay low until AVDD reaches the undervoltage protection (UVP) voltage threshold (see the Electrical Characteristics table of this data sheet). After a precharge time to stabilize the DC voltage across the input AC coupling capacitors, before the ramp up sequence starts.

### 11.3 Powering Down

The TPA3251 does not require a power-down sequence. The device remains fully operational as long as the gate-drive supply (GVDD\_X) voltage and VDD voltage are above the undervoltage protection (UVP) voltage threshold (see the [Electrical Characteristics](#) table of this data sheet). Although not specifically required, it is a good practice to hold  $\overline{\text{RESET}}$  low during power down, thus preventing audible artifacts including pops or clicks by initiating a controlled ramp down sequence of the output voltage.

## 12 Layout

### 12.1 Layout Guidelines

- Use an unbroken ground plane to have good low impedance and inductance return path to the power supply for power and audio signals.
- Maintain a contiguous ground plane from the ground pins to the PCB area surrounding the device for as many of the ground pins as possible, since the ground pins are the best conductors of heat in the package.
- PCB layout, audio performance and EMI are linked closely together.
- Routing the audio input should be kept short and together with the accompanied audio source ground.
- The small bypass capacitors on the PVDD lines of the DUT be placed as close the PVDD pins as possible.
- A local ground area underneath the device is important to keep solid to minimize ground bounce.
- Orient the passive component so that the narrow end of the passive component is facing the TPA3251 device, unless the area between two pads of a passive component is large enough to allow copper to flow in between the two pads.
- Avoid placing other heat producing components or structures near the TPA3251 device.
- Avoid cutting off the flow of heat from the TPA3251 device to the surrounding ground areas with traces or via strings, especially on output side of device.

Netlist for this printed circuit board is generated from the schematic in [Figure 29](#).

## 12.2 Layout Examples

### 12.2.1 BTL Application Printed Circuit Board Layout Example

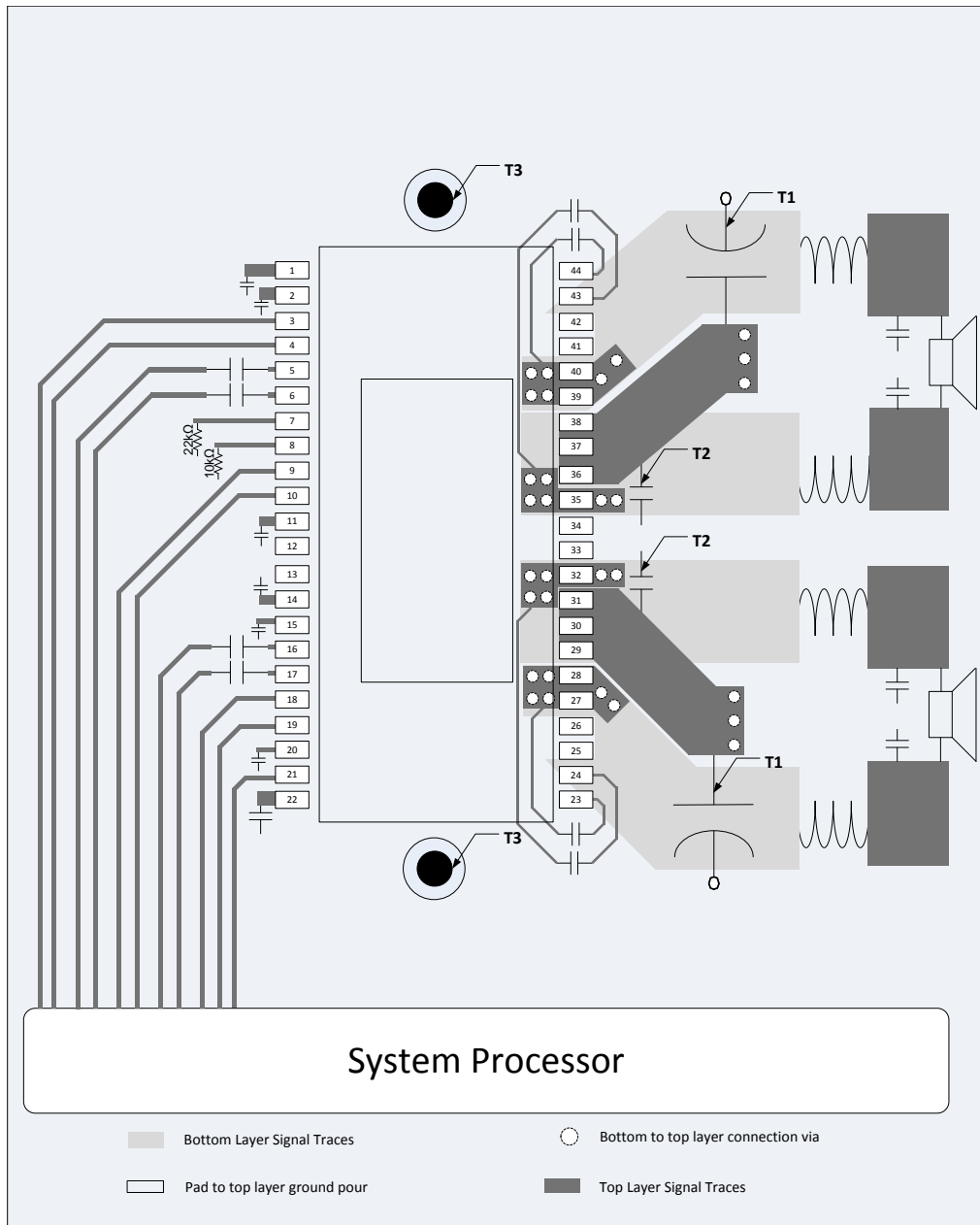

- Note: PCB layout example shows composite layout. Dark grey: Top layer copper traces, light gray: Bottom layer copper traces. All PCB area not used for traces should be GND copper pour (transparent on example image)
- Note T1:** PVDD decoupling bulk capacitors should be as close as possible to the PVDD and GND\_X pins, the heat sink sets the distance. Wide traces should be routed on the top layer with direct connection to the pins and without going through vias. No vias or traces should be blocking the current path.
- Note T2:** Close decoupling of PVDD with low impedance X7R ceramic capacitors is placed under the heat sink and close to the pins.
- Note T3:** Heat sink needs to have a good connection to PCB ground.

**Figure 29. BTL Application Printed Circuit Board - Composite**

Layout Examples (continued)

12.2.2 SE Application Printed Circuit Board Layout Example

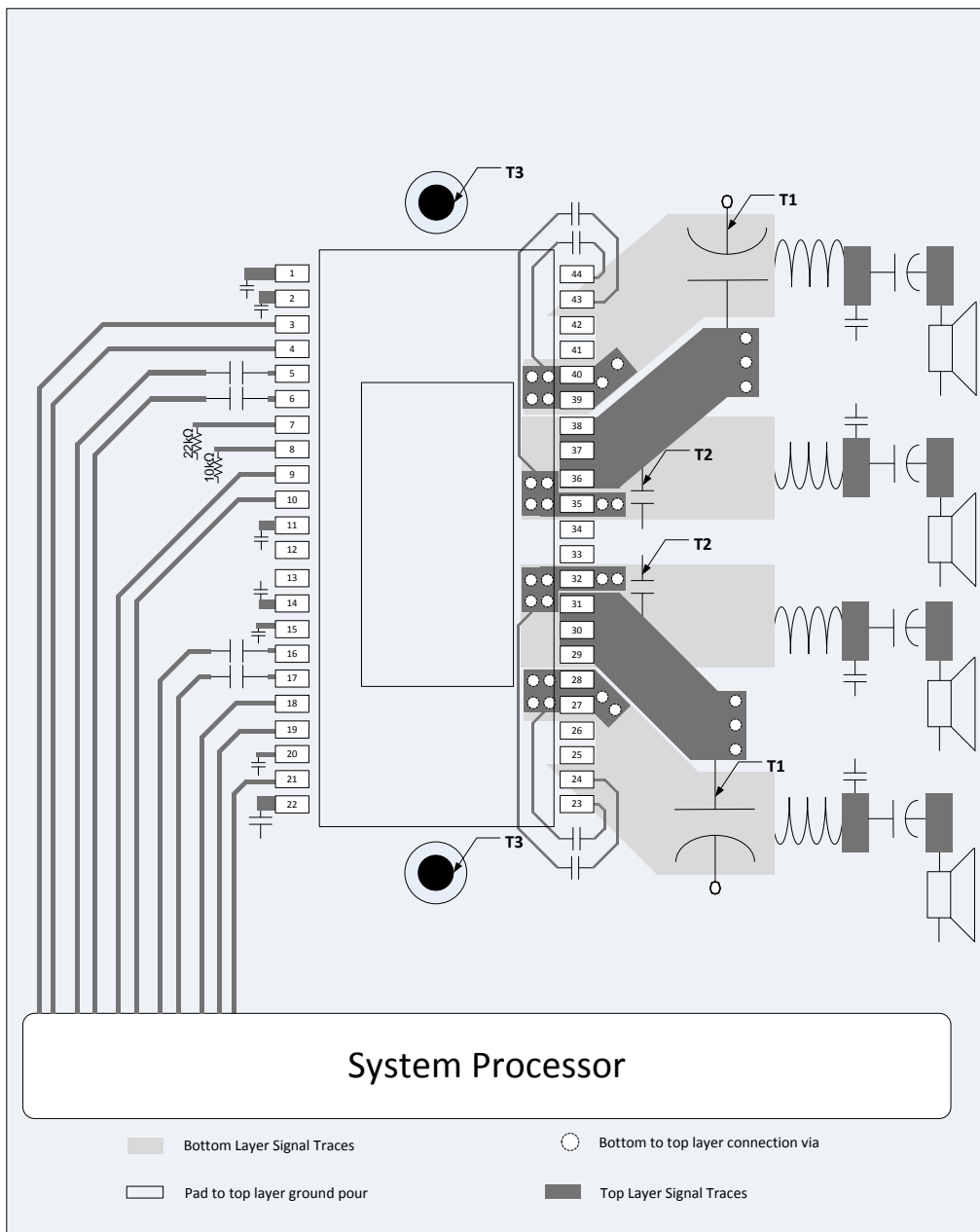

- A. Note: PCB layout example shows composite layout. Dark grey: Top layer copper traces, light gray: Bottom layer copper traces. All PCB area not used for traces should be GND copper pour (transparent on example image)
- B. **Note T1:** PVDD decoupling bulk capacitors should be as close as possible to the PVDD and GND\_X pins, the heat sink sets the distance. Wide traces should be routed on the top layer with direct connection to the pins and without going through vias. No vias or traces should be blocking the current path.
- C. **Note T2:** Close decoupling of PVDD with low impedance X7R ceramic capacitors is placed under the heat sink and close to the pins.
- D. **Note T3:** Heat sink needs to have a good connection to PCB ground.

Figure 30. SE Application Printed Circuit Board - Composite

Layout Examples (continued)

12.2.3 PBTL Application Printed Circuit Board Layout Example

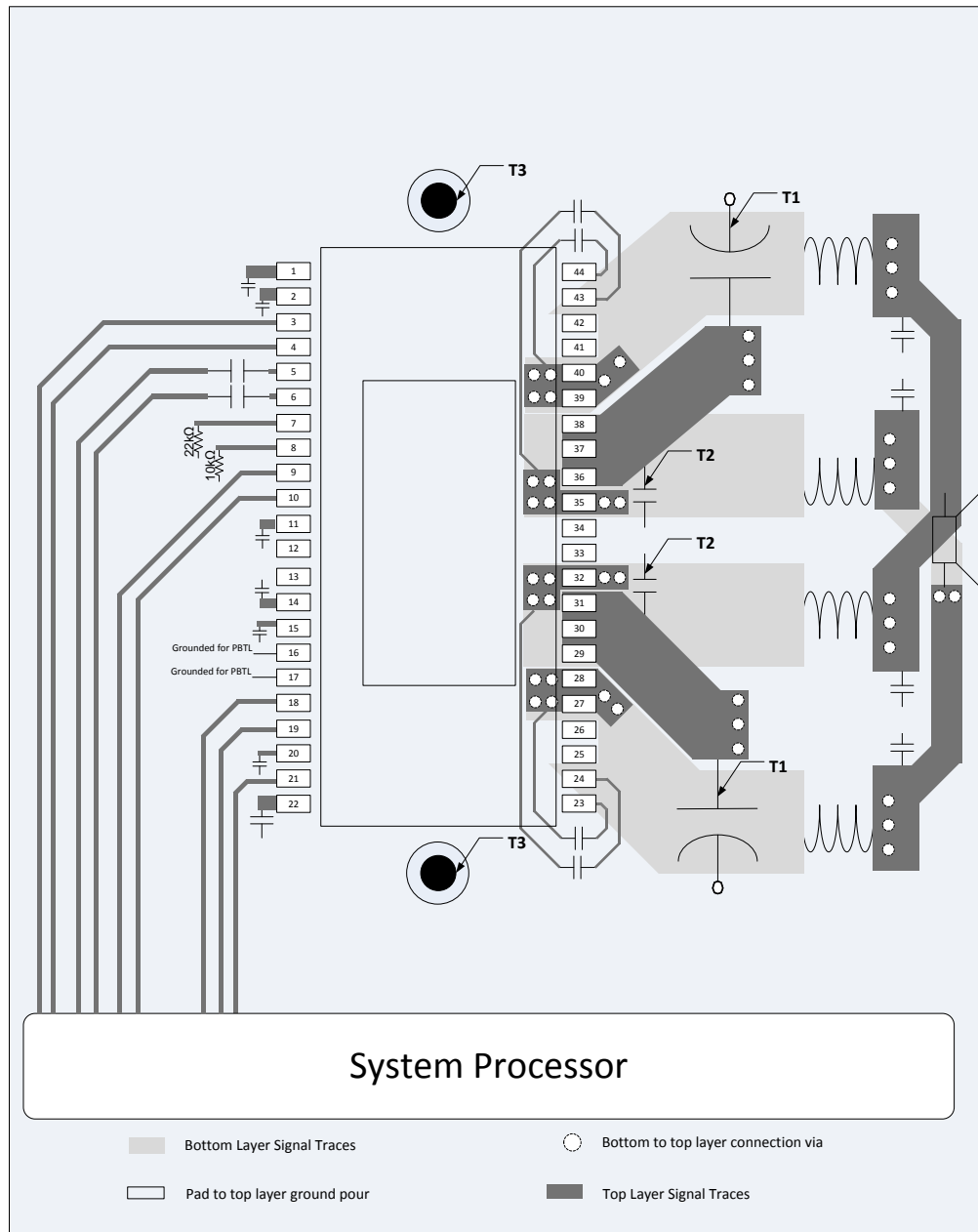

- A. Note: PCB layout example shows composite layout. Dark grey: Top layer copper traces, light gray: Bottom layer copper traces. All PCB area not used for traces should be GND copper pour (transparent on example image)
- B. **Note T1:** PVDD decoupling bulk capacitors should be as close as possible to the PVDD and GND\_X pins, the heat sink sets the distance. Wide traces should be routed on the top layer with direct connection to the pins and without going through vias. No vias or traces should be blocking the current path.
- C. **Note T2:** Close decoupling of PVDD with low impedance X7R ceramic capacitors is placed under the heat sink and close to the pins.
- D. **ote T3:** Heat sink needs to have a good connection to PCB ground.

**Figure 31. PBTL Application Printed Circuit Board - Composite**

## 13 Device and Documentation Support

### 13.1 Documentation Support

TPA3251EVM User's Guide, [SLVUAG8](#)

### 13.2 Community Resources

The following links connect to TI community resources. Linked contents are provided "AS IS" by the respective contributors. They do not constitute TI specifications and do not necessarily reflect TI's views; see TI's [Terms of Use](#).

**TI E2E™ Online Community** *TI's Engineer-to-Engineer (E2E) Community*. Created to foster collaboration among engineers. At [e2e.ti.com](#), you can ask questions, share knowledge, explore ideas and help solve problems with fellow engineers.

**Design Support** *TI's Design Support* Quickly find helpful E2E forums along with design support tools and contact information for technical support.

### 13.3 Trademarks

PurePath, E2E are trademarks of Texas Instruments.  
Blu-ray Disk is a trademark of Blu-ray Disc Association.  
All other trademarks are the property of their respective owners.

### 13.4 Electrostatic Discharge Caution



These devices have limited built-in ESD protection. The leads should be shorted together or the device placed in conductive foam during storage or handling to prevent electrostatic damage to the MOS gates.

### 13.5 Glossary

[SLYZ022](#) — *TI Glossary*.

This glossary lists and explains terms, acronyms, and definitions.

## 14 Mechanical, Packaging, and Orderable Information

The following pages include mechanical, packaging, and orderable information. This information is the most current data available for the designated devices. This data is subject to change without notice and revision of this document. For browser-based versions of this data sheet, refer to the left-hand navigation.

**PACKAGING INFORMATION**

| Orderable Device | Status<br>(1) | Package Type | Package Drawing | Pins | Package Qty | Eco Plan<br>(2)         | Lead/Ball Finish<br>(6) | MSL Peak Temp<br>(3) | Op Temp (°C) | Device Marking<br>(4/5) | Samples                 |
|------------------|---------------|--------------|-----------------|------|-------------|-------------------------|-------------------------|----------------------|--------------|-------------------------|-------------------------|
| TPA3251D2DDV     | ACTIVE        | HTSSOP       | DDV             | 44   | 35          | Green (RoHS & no Sb/Br) | CU NIPDAU               | Level-3-260C-168 HR  | 0 to 70      | 3251                    | <a href="#">Samples</a> |
| TPA3251D2DDVR    | ACTIVE        | HTSSOP       | DDV             | 44   | 2000        | Green (RoHS & no Sb/Br) | CU NIPDAU               | Level-3-260C-168 HR  | 0 to 70      | 3251                    | <a href="#">Samples</a> |

(1) The marketing status values are defined as follows:

**ACTIVE:** Product device recommended for new designs.

**LIFEBUY:** TI has announced that the device will be discontinued, and a lifetime-buy period is in effect.

**NRND:** Not recommended for new designs. Device is in production to support existing customers, but TI does not recommend using this part in a new design.

**PREVIEW:** Device has been announced but is not in production. Samples may or may not be available.

**OBSOLETE:** TI has discontinued the production of the device.

(2) **RoHS:** TI defines "RoHS" to mean semiconductor products that are compliant with the current EU RoHS requirements for all 10 RoHS substances, including the requirement that RoHS substance do not exceed 0.1% by weight in homogeneous materials. Where designed to be soldered at high temperatures, "RoHS" products are suitable for use in specified lead-free processes. TI may reference these types of products as "Pb-Free".

**RoHS Exempt:** TI defines "RoHS Exempt" to mean products that contain lead but are compliant with EU RoHS pursuant to a specific EU RoHS exemption.

**Green:** TI defines "Green" to mean the content of Chlorine (Cl) and Bromine (Br) based flame retardants meet JS709B low halogen requirements of <=1000ppm threshold. Antimony trioxide based flame retardants must also meet the <=1000ppm threshold requirement.

(3) MSL, Peak Temp. - The Moisture Sensitivity Level rating according to the JEDEC industry standard classifications, and peak solder temperature.

(4) There may be additional marking, which relates to the logo, the lot trace code information, or the environmental category on the device.

(5) Multiple Device Markings will be inside parentheses. Only one Device Marking contained in parentheses and separated by a "~" will appear on a device. If a line is indented then it is a continuation of the previous line and the two combined represent the entire Device Marking for that device.

(6) Lead/Ball Finish - Orderable Devices may have multiple material finish options. Finish options are separated by a vertical ruled line. Lead/Ball Finish values may wrap to two lines if the finish value exceeds the maximum column width.

**Important Information and Disclaimer:**The information provided on this page represents TI's knowledge and belief as of the date that it is provided. TI bases its knowledge and belief on information provided by third parties, and makes no representation or warranty as to the accuracy of such information. Efforts are underway to better integrate information from third parties. TI has taken and continues to take reasonable steps to provide representative and accurate information but may not have conducted destructive testing or chemical analysis on incoming materials and chemicals. TI and TI suppliers consider certain information to be proprietary, and thus CAS numbers and other limited information may not be available for release.

In no event shall TI's liability arising out of such information exceed the total purchase price of the TI part(s) at issue in this document sold by TI to Customer on an annual basis.

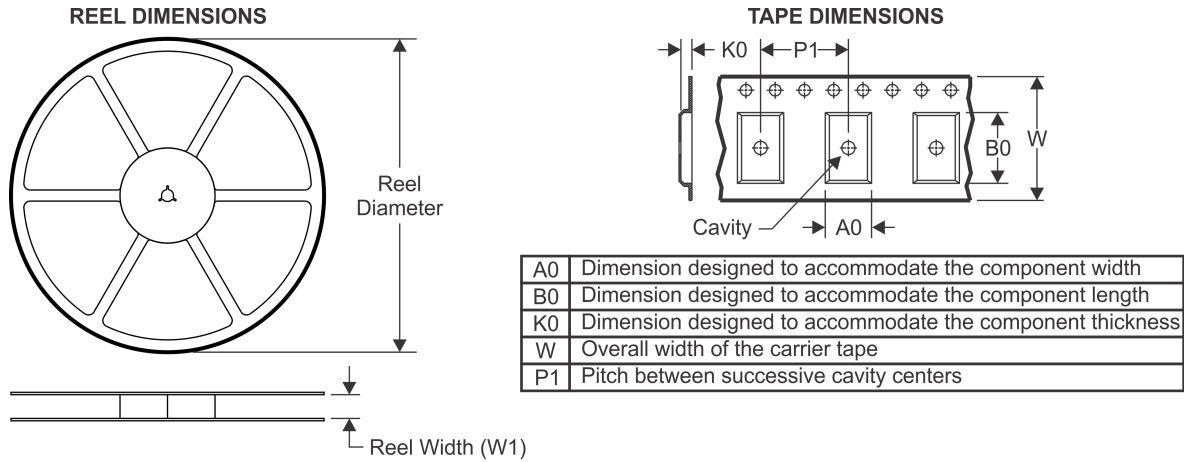
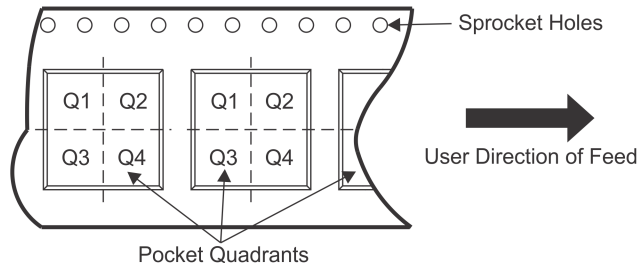

**TAPE AND REEL INFORMATION**

**QUADRANT ASSIGNMENTS FOR PIN 1 ORIENTATION IN TAPE**

\*All dimensions are nominal

| Device        | Package Type | Package Drawing | Pins | SPQ  | Reel Diameter (mm) | Reel Width W1 (mm) | A0 (mm) | B0 (mm) | K0 (mm) | P1 (mm) | W (mm) | Pin1 Quadrant |
|---------------|--------------|-----------------|------|------|--------------------|--------------------|---------|---------|---------|---------|--------|---------------|
| TPA3251D2DDVR | HTSSOP       | DDV             | 44   | 2000 | 330.0              | 24.4               | 8.6     | 15.6    | 1.8     | 12.0    | 24.0   | Q1            |

**TAPE AND REEL BOX DIMENSIONS**

\*All dimensions are nominal

| Device        | Package Type | Package Drawing | Pins | SPQ  | Length (mm) | Width (mm) | Height (mm) |
|---------------|--------------|-----------------|------|------|-------------|------------|-------------|
| TPA3251D2DDVR | HTSSOP       | DDV             | 44   | 2000 | 350.0       | 350.0      | 43.0        |

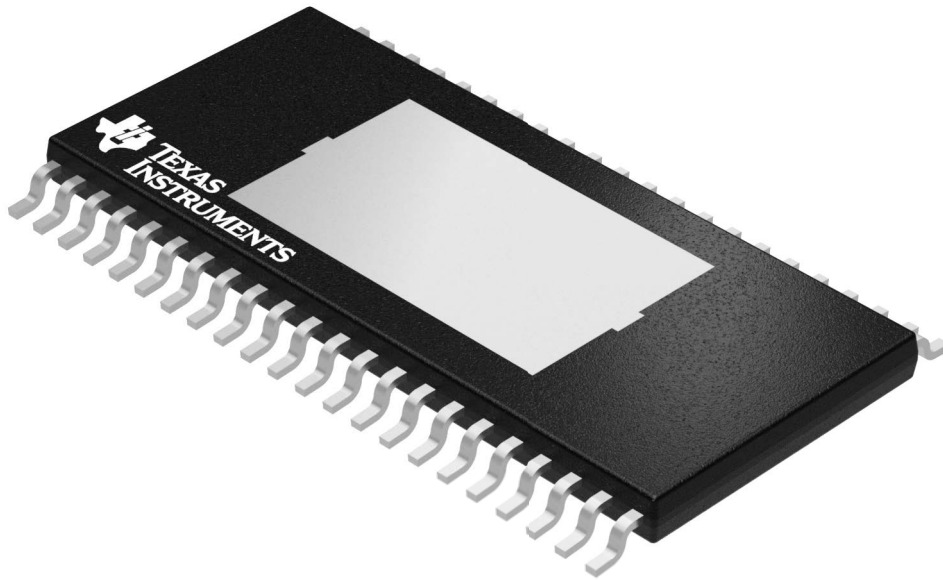

Images above are just a representation of the package family, actual package may vary.  
Refer to the product data sheet for package details.

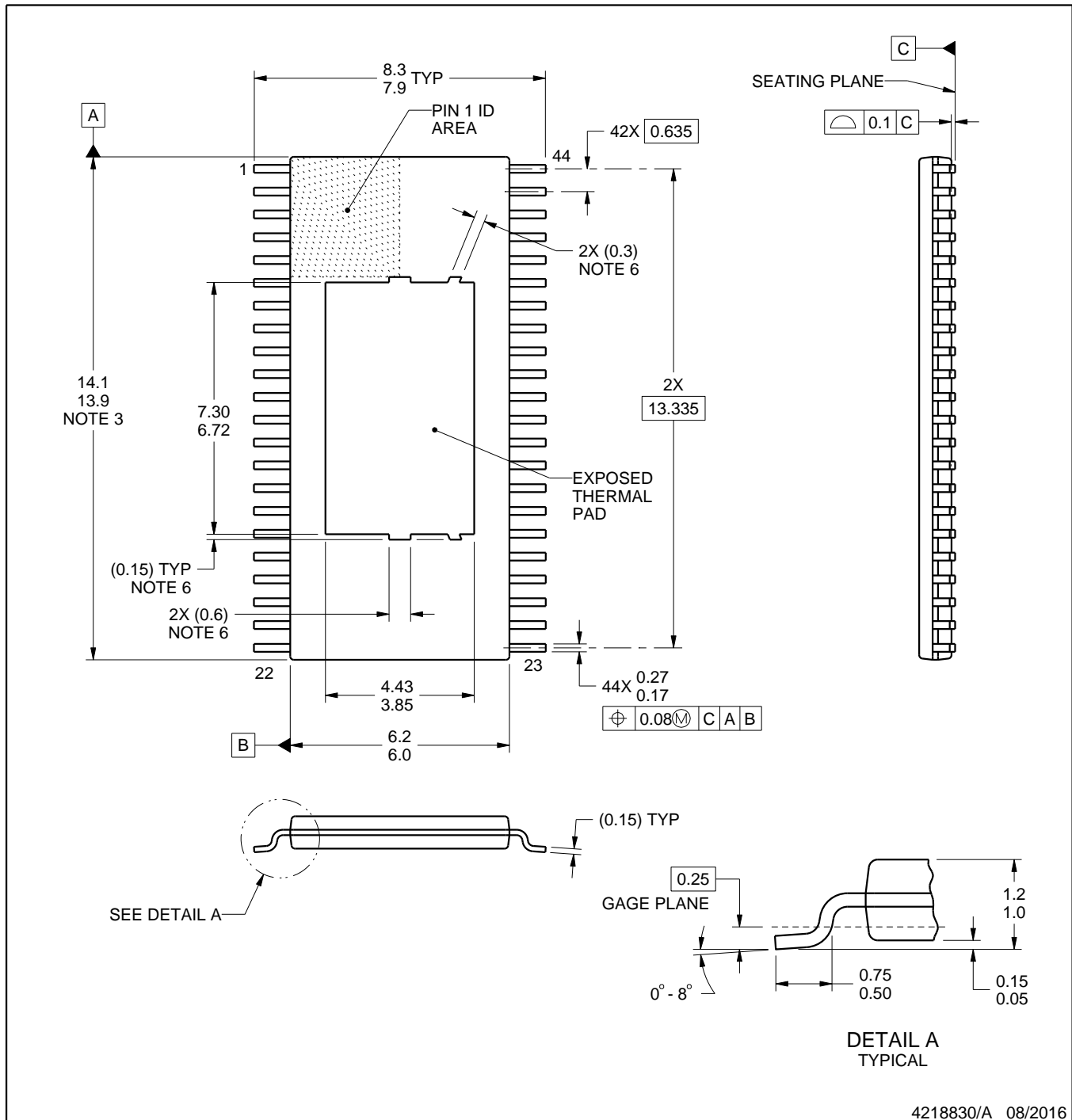
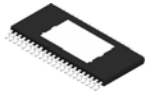

4218830/A 08/2016

## NOTES:

PowerPAD is a trademark of Texas Instruments.

1. All linear dimensions are in millimeters. Any dimensions in parenthesis are for reference only. Dimensioning and tolerancing per ASME Y14.5M.
2. This drawing is subject to change without notice.
3. This dimension does not include mold flash, protrusions, or gate burrs. Mold flash, protrusions, or gate burrs shall not exceed 0.15 mm per side.
4. Reference JEDEC registration MO-153.
5. The exposed thermal pad is designed to be attached to an external heatsink.
6. Features may differ or may not be present.

# EXAMPLE BOARD LAYOUT

DDV0044D

PowerPAD™ TSSOP - 1.2 mm max height

PLASTIC SMALL OUTLINE

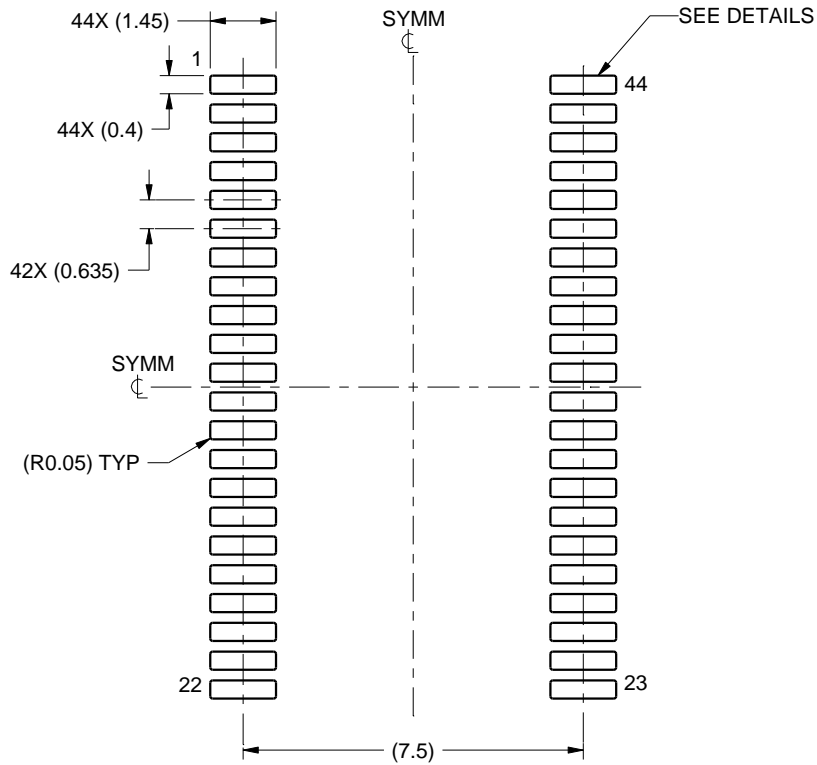

LAND PATTERN EXAMPLE  
SCALE:6X

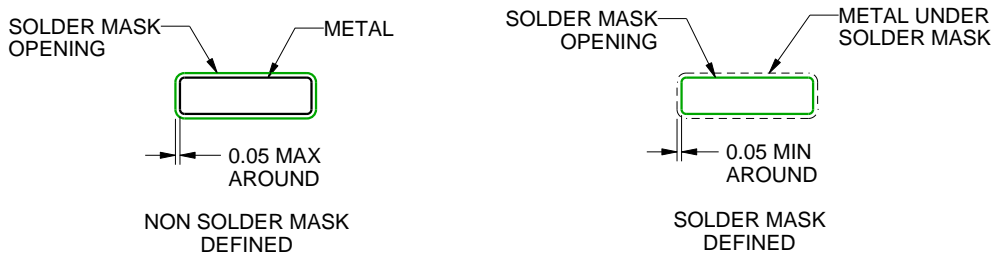

SOLDER MASK DETAILS  
NOT TO SCALE

4218830/A 08/2016

NOTES: (continued)

- 7. Publication IPC-7351 may have alternate designs.
- 8. Solder mask tolerances between and around signal pads can vary based on board fabrication site.

# EXAMPLE STENCIL DESIGN

DDV0044D

PowerPAD™ TSSOP - 1.2 mm max height

PLASTIC SMALL OUTLINE

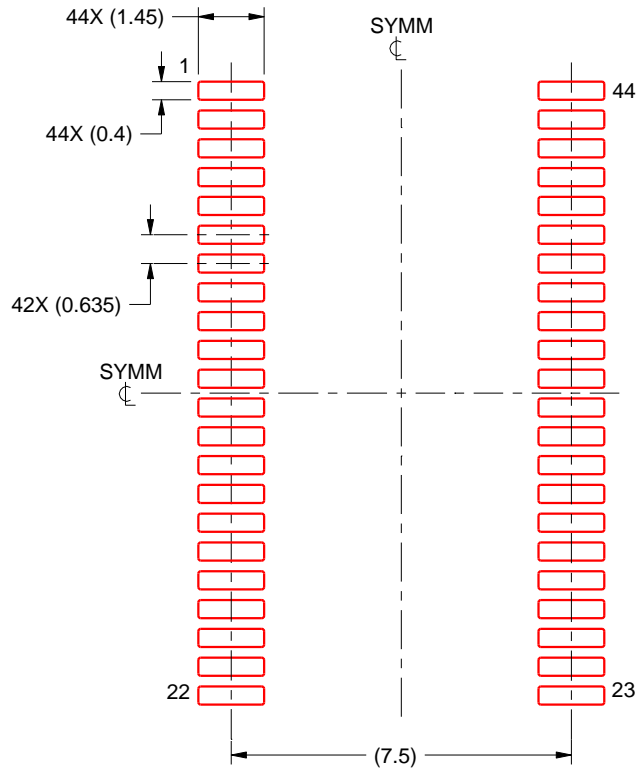

SOLDER PASTE EXAMPLE  
BASED ON 0.125 MM THICK STENCIL  
SCALE :6X

4218830/A 08/2016

NOTES: (continued)

9. Laser cutting apertures with trapezoidal walls and rounded corners may offer better paste release. IPC-7525 may have alternate design recommendations.
10. Board assembly site may have different recommendations for stencil design.

## IMPORTANT NOTICE AND DISCLAIMER

TI PROVIDES TECHNICAL AND RELIABILITY DATA (INCLUDING DATASHEETS), DESIGN RESOURCES (INCLUDING REFERENCE DESIGNS), APPLICATION OR OTHER DESIGN ADVICE, WEB TOOLS, SAFETY INFORMATION, AND OTHER RESOURCES "AS IS" AND WITH ALL FAULTS, AND DISCLAIMS ALL WARRANTIES, EXPRESS AND IMPLIED, INCLUDING WITHOUT LIMITATION ANY IMPLIED WARRANTIES OF MERCHANTABILITY, FITNESS FOR A PARTICULAR PURPOSE OR NON-INFRINGEMENT OF THIRD PARTY INTELLECTUAL PROPERTY RIGHTS.

These resources are intended for skilled developers designing with TI products. You are solely responsible for (1) selecting the appropriate TI products for your application, (2) designing, validating and testing your application, and (3) ensuring your application meets applicable standards, and any other safety, security, or other requirements. These resources are subject to change without notice. TI grants you permission to use these resources only for development of an application that uses the TI products described in the resource. Other reproduction and display of these resources is prohibited. No license is granted to any other TI intellectual property right or to any third party intellectual property right. TI disclaims responsibility for, and you will fully indemnify TI and its representatives against, any claims, damages, costs, losses, and liabilities arising out of your use of these resources.

TI's products are provided subject to TI's Terms of Sale ([www.ti.com/legal/termsofsale.html](http://www.ti.com/legal/termsofsale.html)) or other applicable terms available either on [ti.com](http://ti.com) or provided in conjunction with such TI products. TI's provision of these resources does not expand or otherwise alter TI's applicable warranties or warranty disclaimers for TI products.

Mailing Address: Texas Instruments, Post Office Box 655303, Dallas, Texas 75265  
Copyright © 2019, Texas Instruments Incorporated

## Looking for pricing, stock, or lifecycle information?

Click below to explore more details on WIN SOURCE:

 [View TPA3251D2DDVR on WIN SOURCE](#)

 [Texas Instruments](#) Information

## Optimize Your Supply Chain with WIN SOURCE Solutions

-  Global Sourcing Solution
-  Obsolete Management
-  Cost Control Management
-  Shortage Management
-  Alternative Solution
-  Excess Inventory Management