



**THE DATASHEET OF  
AEAT-86AD-LASC0**



# AEAT-86AD

## 14/12 Bit Multi-turn Encoder Module with Built-in Controller



### Data Sheet

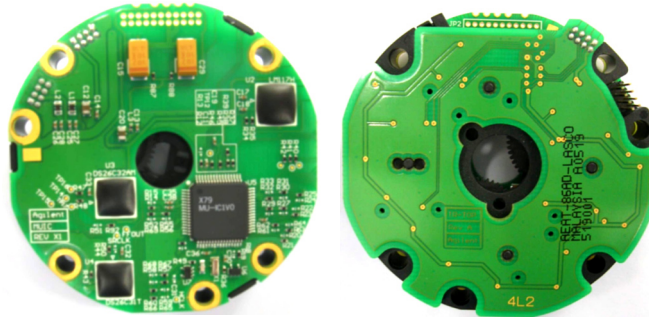

#### Description

The AEAT-86AD provides all functions as an optoelectronic mechanical unit in order to implement, with single turn absolute encoder, an absolute multi-turn encoder with a combined capacity of up to 30 bits at extended temperature.

The unit consists of an LED circuit board, a phototransistor (PT) circuit board, and gear train arranged in between the PCBs.

The built-in controller combined positional information from single turn absolute encoder and multiturn absolute encoder. It provides control inputs and signal outputs to application end. The integrated RS-422 differential line driver output and line receiver are for noise immunity in transmission line.

#### Specifications

The multi-turn unit is available in the following versions:

- 12-bit solid shaft with *Binary* output code
- 14-bit solid shaft with *Binary* output code
- 12-bit solid shaft with *Gray* output code
- 14-bit solid shaft with *Gray* output code

#### Features

- 16384 (14bits) and 4096 (12bits) revolution count versions
- Optical, absolute multi-turn assembly with max. Ø55 mm and typical height 13.3 mm.
- Operating temperatures of -40°C to +125°C
- Mechanical coupling by means of gear wheels with module of 0.3
- Operating speeds up to 12,000 rpm
- A 2x4-pole pin strip for power supply and signal
- Integrated RS422 line driver and receiver

#### Applications

- Major component of Multi-turn housed encoder
- Cost effective solution for direct integration into OEM systems
- Revolution detection

#### Benefits

- No battery or capacitor required for number of revolution counting during power failure
- Immediate position detection on power up

## Package Dimensions

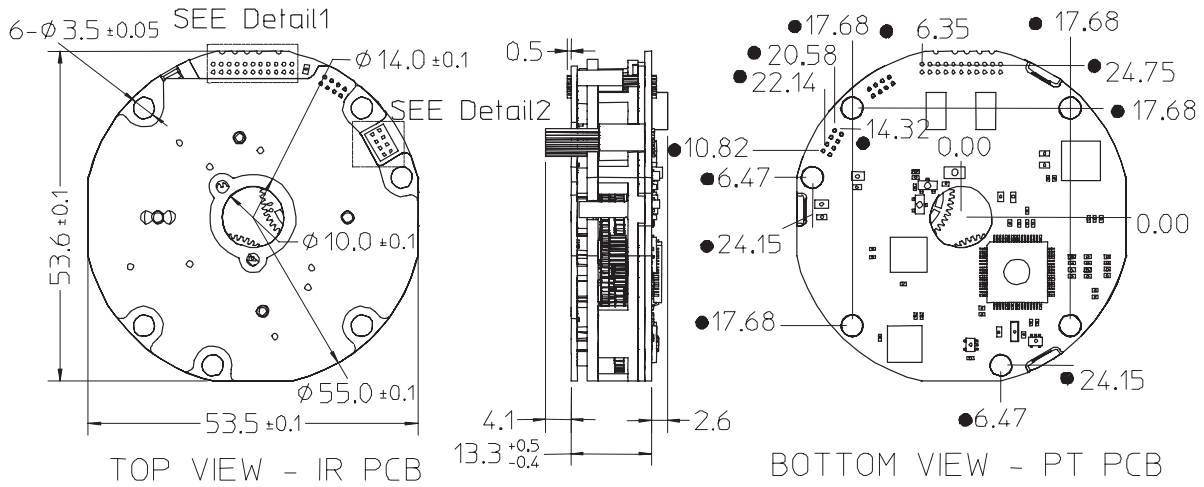

### Notes:

1. 3rd angle Projection
2. Dimensions are in millimeters
3. General tolerance:  $\pm 0.05$ , unless specified otherwise

Figure 1. Package dimensions

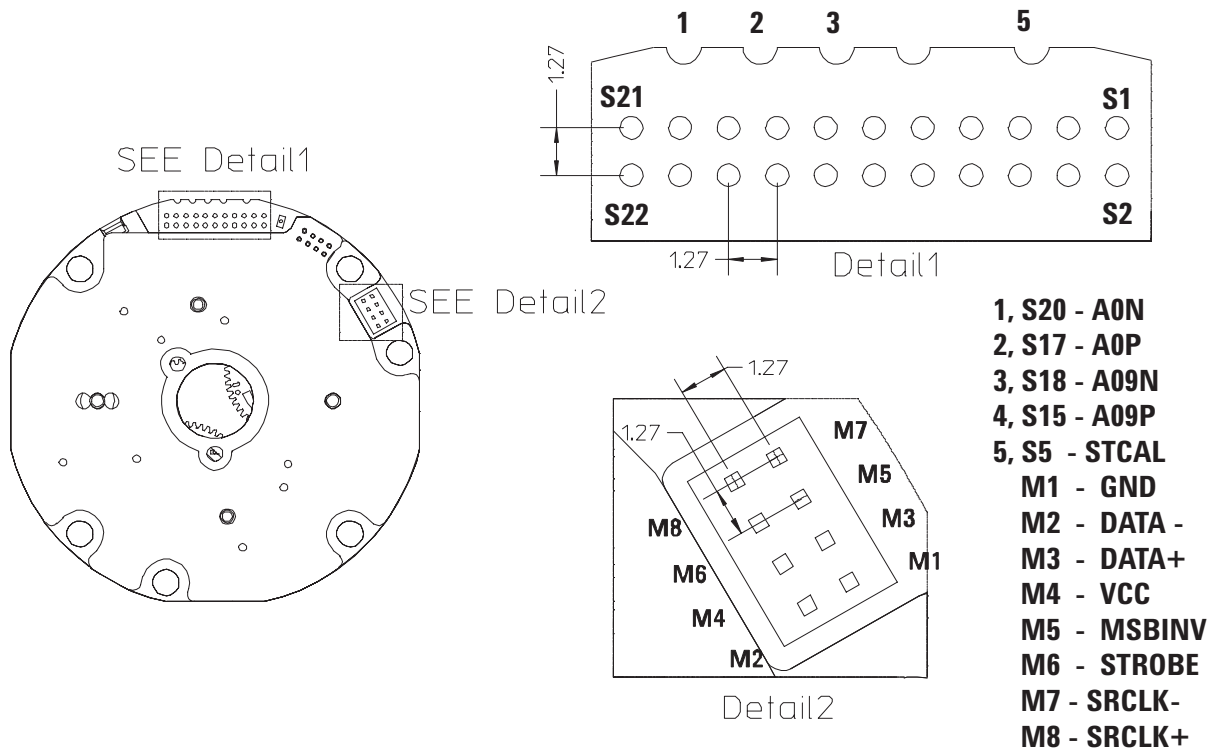

Figure 2. Pin Configuration

## Block Diagram and Detailed Description

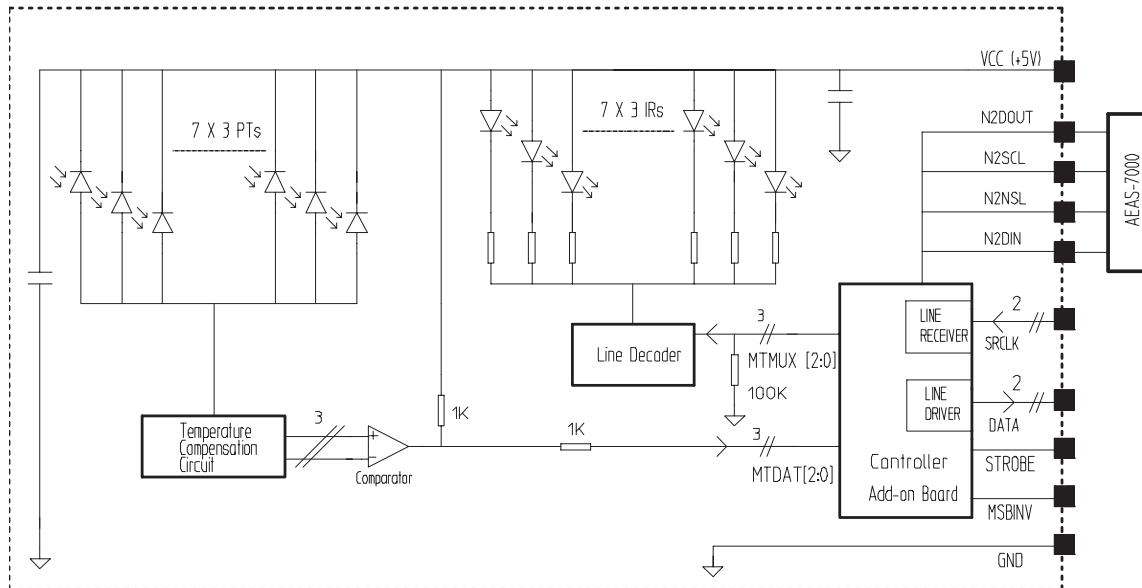

Figure 3. Block Diagram

### GENERAL

AEAT-86AD Multiturn Encoder Module is integrated with a controller. The controller provides data synchronization between Single Turn Absolute Encoder Module (i.e. AEAS-7X00) and basic multiturn encoder module. Its combines the serial data from both modules into combined ( $n_{MT} + n_{ST}$ ) bit resolution to application end.

The most significant bit (MSB) will always be sent first to DATA+.

With integrated RS422 line driver and receiver, the differential data transmission is compatible with EIA standard RS-422.

### SRCLK+ and SRCLK -

SRCLK input pins are used to clocked out the serial outputs data through the DATA pins. Lapse time between words or subsequent data frame must be 40  $\mu$ s or longer for proper data transmission.

### DATA+ and DATA -

DATA output pins provides positional information via synchronous serial interface, which consists of  $n_{MT}$  bit of serial data from multiturn module and  $n_{ST}$  bit of serial data from single turn module.

### MSBINV

The MSB can be inverted (counting direction) by using MSBINV.

### STROBE

STROBE output pin can be used to determine whether the data is locked or changing. It is high when date is locked, but low when data is changing.

### CONNECTION TO AEAS-7X00

Besides VDDA, VDD and GND of AEAS-7x00 need to be connected to the Multiturn Encoder Module, data and control i/o pins also need to be connected and soldered, i.e. NSDOUT, N2SCL, N2NSL and N2DIN

### NOTE:

$n_{MT}$  = resolution of multiturn module  
 $n_{ST}$  = resolution of single turn module

## Device Selection Guide <sup>1</sup>

Part Number	Resolution	Operating Temperature (°C)	Output Code	DC Supply Voltage (V)
AEAT-86AD-LASC0	12 bit	-40 to 125	Binary	+5.0 to +5.5
AEAT-86AD-LASF0	14 bit	-40 to 125	Binary	+5.0 to +5.5
AEAT-86AD-LCSC0	12 bit	-40 to 125	Gray	+5.0 to +5.5
AEAT-86AD-LCSF0	14 bit	-40 to 125	Gray	+5.0 to +5.5

Notes:

1. For other options of Multiturn Encoder Module, please refer to factory.

## Absolute Maximum Ratings <sup>1,2</sup>

Parameter	Symbol	Limits	Units
DC Supply Voltage	V <sub>CC</sub>	-0.3 to + 6.0	V
Input Voltage	V <sub>i</sub>	-0.5 to +5.5	V
Output Voltage	V <sub>o</sub>	-0.5 to +V <sub>CC</sub> +0.5	V
Relative Air Humidity (Non-Condensing)	%RH	85	%
Encoder Shaft Speed	S <sub>RPM</sub>	Max 12000	rpm
Storage Temperature	T <sub>stg</sub>	-40 to 125	°C

Notes:

1. Stresses greater than those listed under Absolute Maximum Ratings may cause permanent damage to the device. This is stress rating only and functional operation of the device at these or any other conditions above those indicated in the operational sections of this specification is not implied.
2. Exposure to absolute maximum rating conditions for extended periods may affect reliability.
3. This device meets the ESD ratings of the IEC61000-4-2 Level 1 (2KV).

## Recommended Operating Condition

Parameter	Symbol	Values	Units	Notes
DC Supply Voltage	V <sub>CC</sub>	+5.0 / +5.5	V	
Ambient Temperature	T <sub>amb</sub>	- 40 to +125	°C	
Hardware Clock	f <sub>HCLK</sub>	16	MHz	1
SSI Serial Clock	f <sub>SRCLK</sub>	0.5 to 4	MHz	
Encoder Shaft Speed	S <sub>RPM</sub>	10000 or below	rpm	2

Notes:

1. Internal hardware clock that is built into the module
2. As unique coded gear-wheels techniques are implemented to generate unambiguous positional information, the interactions between these high wear resistant gear wheels are subjected to mechanical wear and tear.

## DC Characteristics

DC Characteristics over Recommended Operating Range, typical at 25 °C

Parameter	Symbol	Condition	Values			Units	Notes
			Min	Typ.	Max		
Output High Voltage	$I_{OH}$	$I_{OH} = -8\text{mA}$	2.4			V	1
Output Low Voltage	$I_{OL}$	$I_{OL} = 8\text{mA}$			0.4	V	1
Input High Voltage	$V_{IH}$		2			V	2
Input Low Voltage	$V_{IL}$				0.8	V	2
$V_{CC}$ Supply Current	$I_{CC}$				110	mA	

Notes:

1. Only applicable for STROBE output.
2. Only applicable for MSBINV input.
3. RS-422 differential line driver for DATA output.
4. RS-422 differential line receiver for SRCLK input.

## Timing Characteristics

Timing Characteristics over Recommended Operating Range, typical at 25 °C

Parameter	Symbol	Condition	Values			Units	Notes
			Min	Typ.	Max		
Input Transition Rise/Fall Time	$t_R/t_F$	0.8V/2.0V			10	ns	1
SRCLK Frequency	$f_{SRCLK}$		0.5		4	MHz	2
SRCLK Low-time	$t_{LSRCLK}$		110			ns	
SRCLK High-time	$t_{HSRCLK}$		70			ns	
Data Latch time	$t_{LATCH}$			35		$\mu\text{s}$	3
Lapse time between words	$t_{LT}$		40			$\mu\text{s}$	3, 4

Notes:

1. Only applicable for MSBINV input.
2.  $t_{LSRCLK} = 0.50/f_{SRCLK}$ ;  $t_{HSRCLK} = 0.50/f_{SRCLK}$ .
3. Refer to Figure 4 for timing description.
4. Valid data on falling edges of SRCLK with STROBE is high.

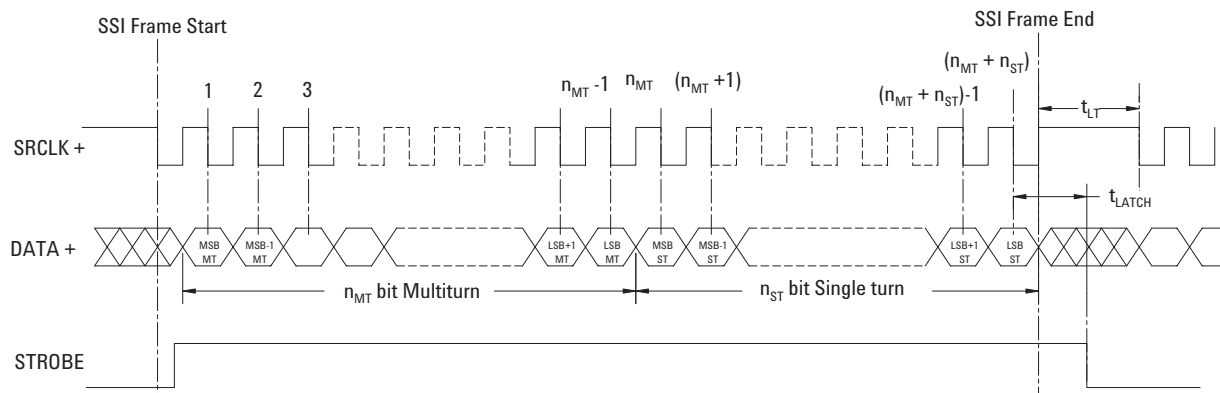

Figure 4. Timing Characteristics of STROBE, SRCLK and DATA

## Pin Description

No.	Pin Name	Description	Function	Notes
<b>Pin out for test</b>				
1	A0N	Analog Output	A0 negative (- True dif)	1
2	A0P	Analog Output	A0 positive (+True diff.)	1
3	A09N	Analog output	A09 negative (-True diff.)	1
4	A09P	Analog output	A09 positive (+True diff.)	1
5	STCAL	Digital Input	Do not use unnecessarily	1
<b>Pin out between ST and MT</b>				
S1	NC		Do not connect	
S2	KORR	Digital-input	Do not connect	
S3	PROBE_ON	Digital-Input	Do not connect	
S4	PCL	Digital Input Positive edge	Do not connect	
S5	STCAL	Digital Input	Do not connect	
S6	MSBINV	Digital-Input	Do not connect	
S7	N2DIN	Digital Input	To be connect to AEAS-7000 DIN	2
S8	N2NSL	Digital-Input	To be connect to AEAS-7000 NSL	2
S9	N2SCL	Digital-Input Positive Edge	Shift-register Clock To be connect to AEAS-7000 SCL	2
S10	N2DOUT	Digital Output	Shift-Register Data Out To be connect to AEAS-7000 DOUT	2
S11	DO	Digital Output	Do not connect	
S12	DPROBE	Digital Output	Do not connect	
S13	VDD	Supply Voltage	+5V Supply Digital to AEAS-7000	2, 3
S14	GND	Ground for supply voltage	GND for 5V supply analog/digital	2, 3
S15	A09P	Analog output	Do not connect	
S16	GND	Ground for supply voltage	GND for 5V supply analog/digital	2, 3
S17	A0P	Analog Output	Do not connect	
S18	A09N	Analog output	Do not connect	
S19	VDDA	Supply Voltage	+5V Supply Analog to AEAS-7000	2, 3
S20	A0N	Analog Output	Do not connect	
S21	LERR	Digital Output	Do not connect	
S22	LEDR	Analog Output	Do not connect	
<b>Pin out between MT and External</b>				
M1	GND	Ground for supply voltage	GND for 5V supply analog/digital	
M2	DATA -	Digital Output	SSI Data -	
M3	DATA +	Digital Output	SSI Data +	
M4	VCC	Supply Voltage	+5V Supply analog/digital	
M5	MSBINV	Digital Input	0= Counting without inversion 1= Counting with inversion	
M6	STROBE	Digital Output	Data latching	
M7	SRCLK -	Digital Input	Shift-register Clock -	
M8	SRCLK +	Digital Input	Shift-register Clock +	

### Notes:

1. Only use for test purposes.
2. Refer to AEAS-7000 datasheet for detailed pin description.
3. Power supply and ground from Multi-turn module to Single turn module.

## Application Note

The encoder is mechanically fixed by means of holes in adapters, which accommodate M3 threads. The encoder has 2 adapters for attaching in a 3 x 120° and 4 x 90° arrangement. For details, please refer to the mechanical drawings in Figure 5.

The mechanical coupling of the encoder shaft is realised by means of gear opinion with a module of 0.3, 14 teeth. The zero positions of the coupling wheels are locked with a plastic plug for alignment to the single turn absolute encoder, with the coupling wheel being able to compensate for an angle error of about +/-7°.

The electrical connection is realized by means of a 2x4 pin strip (1.27mm pitch), which is plugged into a corresponding female connector.

The encoder is attached with a plastic plug that locks the absolute zero position. During the mating of the gear wheel and the encoder coupling wheel it may be necessary to align the teeth of the gears for proper matching. The plastic plug can be removed upon integration with the gear wheel.

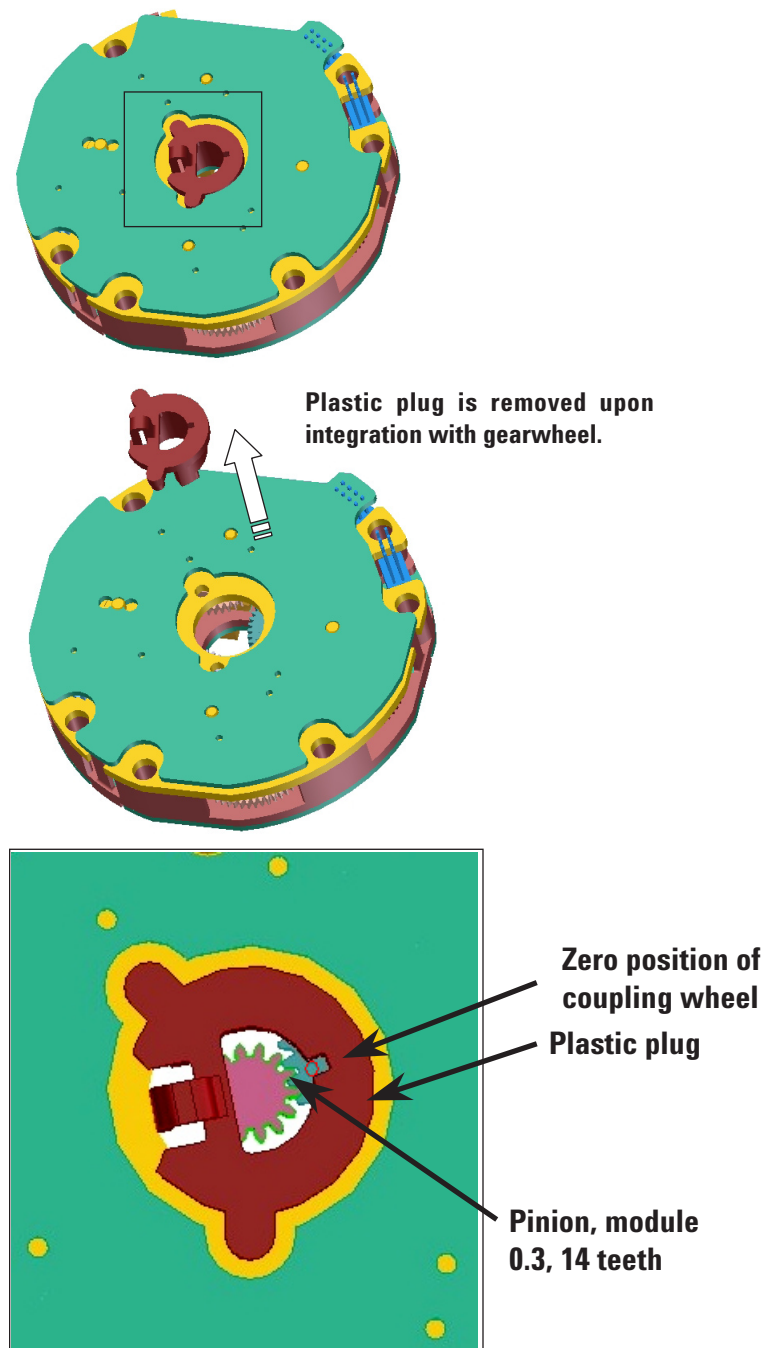
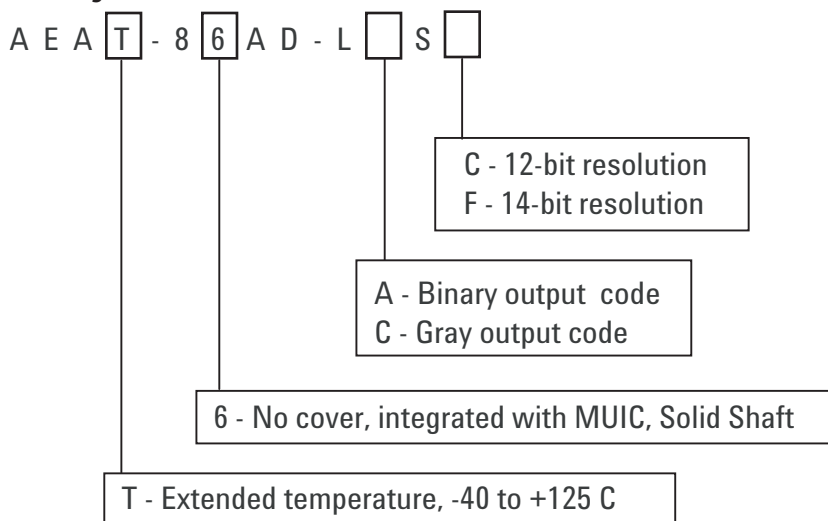

Figure 5. Mechanical coupling with Multiturn Encoder Module

## Ordering Information



### Available options:

AEAT-86AD-LASC0

AEAT-86AD-LASF0

AEAT-86AD-LCSC0

AEAT-86AD-LCSF0

For product information and a complete list of distributors, please go to our web site: [www.avagotech.com](http://www.avagotech.com)

Avago, Avago Technologies, and the A logo are trademarks of Avago Technologies, Pte. in the United States and other countries.  
Data subject to change. Copyright © 2006 Avago Technologies Pte. All rights reserved.. Obsoletes 5989-3439EN.  
AV01-0254EN - July 14, 2006

**AVAGO**  
TECHNOLOGIES

## Looking for pricing, stock, or lifecycle information?

Click below to explore more details on WIN SOURCE:

- ⊖ [View AEAT-86AD-LASC0 on WIN SOURCE](#)
- ⊖ [Broadcom Limited Information](#)

## Optimize Your Supply Chain with WIN SOURCE Solutions

- ✓ Global Sourcing Solution
- ✓ Obsolete Management
- ✓ Cost Control Management
- ✓ Shortage Management
- ✓ Alternative Solution
- ✓ Excess Inventory Management