



**THE DATASHEET OF
BD8266EFV-ME2**



System motor driver for CD/DVD Player

4ch System Motor Driver for Car Audio

BD8266EFV-M

●General Description

BD8266EFV-M is BTL driver of 5 inputs and 4 outputs for Car CDs developed for SPINDLE motor (CH1), SLED/LOADING motor (CH2) and coil drive for actuator(CH3:TRAKING CH4:FOCUS). It can drive motor and coil of the CD/DVD drive.

●Features

- Drive at PowVCC=5V and 8V with wide Maximum Output Amplitude .
- Switches SLED/LOADING input by CNT terminal.
- Incorporates mute function by CNT terminal and MUTE terminal.
- Preventing the overcurrent to the load by the FOCUS Over Current Protection (OCP) function.
- Built-in TSD, UVLO.
- PowVCC1 and PowVCC2 are independent, and an efficient drive is possible.
PowVCC1 : for SPINDLE&SLED/LOADING.
PowVCC2 : for TRAKING & FOCUS.
- AEC-Q100 Qualified

●Applications

- Car Audio

●Key Specifications

- Input voltage range: 4.5V to 10.0V
- Operating temperature range -40°C to +85°C

PowVCC1=PowVCC2=8V, RL=8Ω

- Maximum Output Amplitude (CH1) 6.5V(Typ.)
- Maximum Output Amplitude (CH2) 7.0V(Typ.)
- Maximum Output Amplitude (CH3,CH4) 6.0V(Typ.)

PowVCC1=PowVCC2=5V, RL=8Ω

- Maximum Output Amplitude (CH1) 4.1V(Typ.)
- Maximum Output Amplitude (CH2) 4.5V(Typ.)
- Maximum Output Amplitude (CH3,CH4) 3.8V(Typ.)

●Package

HTSSOP-B24

W(Typ.) D(Typ.) H(Max.)
7.80mm x 7.60mm x 1.00mm

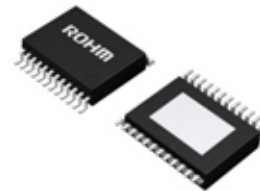

HTSSOP-B24

●Typical Application Circuit

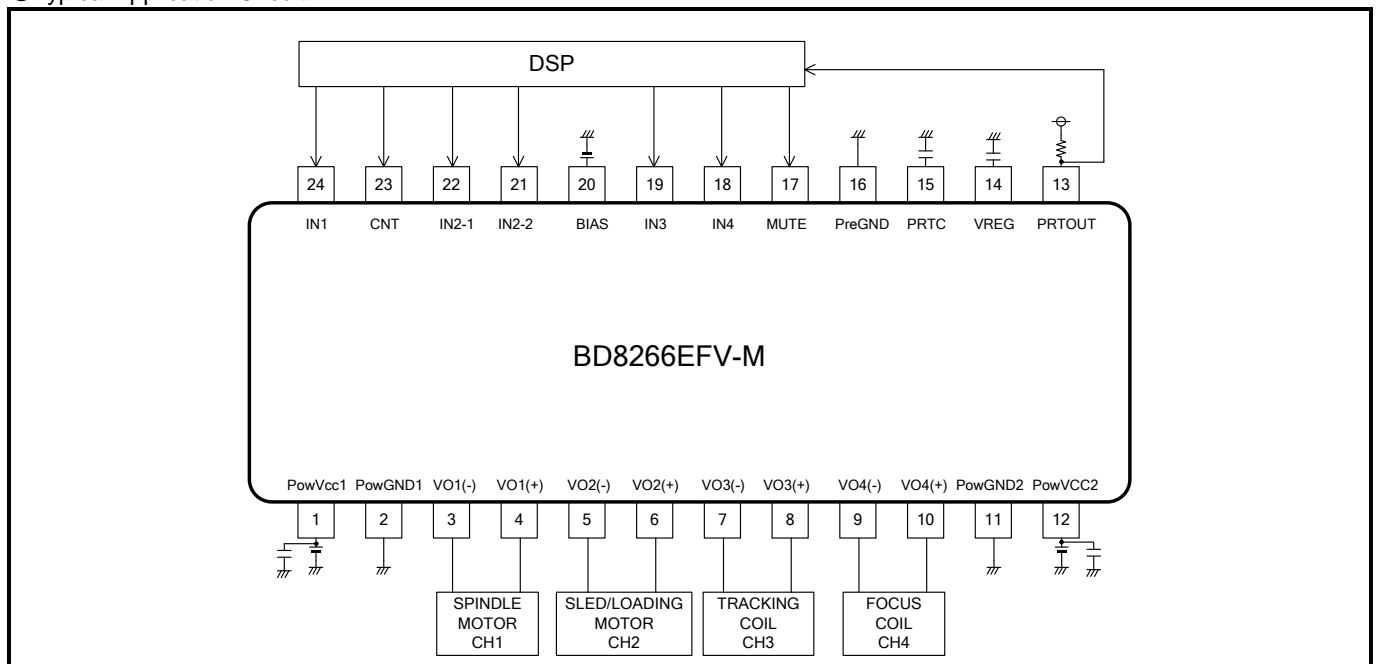

Figure 1. Typical Application Circuit

○Product structure : Silicon monolithic integrated circuit ○This product is not designed protection against radioactive rays

www.rohm.com

© 2012 ROHM Co., Ltd. All rights reserved.
TSZ22111 · 14 · 001

●Pin Configuration (TOPVIEW)

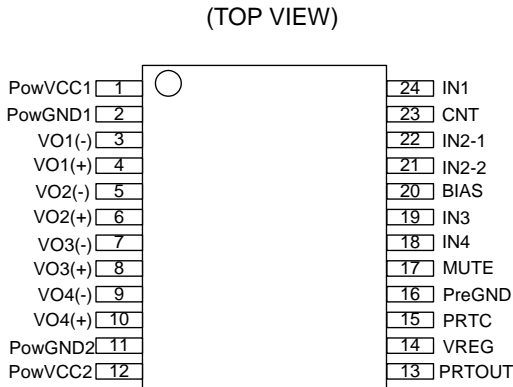

Figure 2. Pin Configuration

●Pin Description

NO.	Signal	Function
1	PowVCC1	CH1,2 Power Supply Input
2	PowGND1	Power GND1
3	VO1(-)	Driver CH1 negative output
4	VO1(+)	Driver CH1 positive output
5	VO2(-)	Driver CH2 negative output
6	VO2(+)	Driver CH2 positive output
7	VO3(-)	Driver CH3 negative output
8	VO3(+)	Driver CH3 positive output
9	VO4(-)	Driver CH4 negative output
10	VO4(+)	Driver CH4 positive output
11	PowGND2	Power GND2
12	PowVCC2	CH3,4 Power Supply Input
13	PRTOUT	Output overcurrent protection flag
14	VREG	Power output for internal logic
15	PRTC	Overcurrent protection function ON time setting
16	PreGND	Pre part GND
17	MUTE	Mute
18	IN4	CH4 (FC:FOCUS) input
19	IN3	CH3 (TK:TRACKING) input
20	BIAS	BIAS input
21	IN2-2	CH2-2 (LD:LOADING) input
22	IN2-1	CH2-1 (SL:SLED)input
23	CNT	Control input
24	IN1	IN1 (SP:SPINDLE)input

●Block Diagram

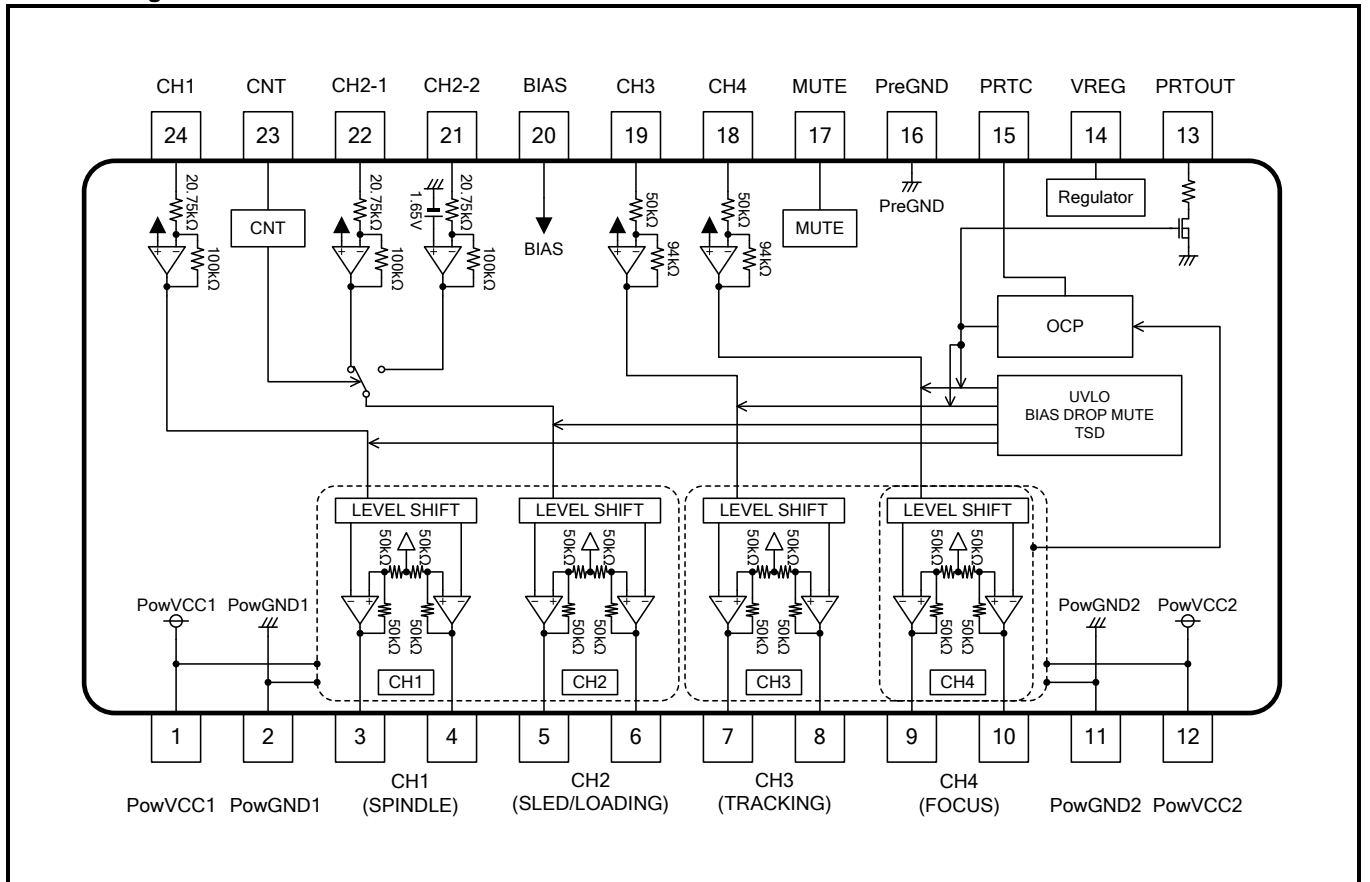

Figure 3. Block Diagram

● Absolute Maximum Ratings (Ta=25°C)

Parameters	Symbol	Value	Units
Power Supply	PowVCC1 PowVCC2	15	V
Input Terminal Voltage 1	VIN1 ^{*1}	PowVCC1	V
Input Terminal Voltage 2	VIN2 ^{*2}	7	V
Output Terminal Voltage 1	VOOUT1 ^{*3}	PowVCC1	V
Output Terminal Voltage 2	VOOUT2 ^{*4}	7	V
Power dissipation	Pd	1.1 ^{*5}	W
		4.0 ^{*6}	
Operating temperature range	Topr	-40 to +85	°C
Storage temperature	Tstg	-55 to +150	°C
Junction temperature	Tjmax	+150	°C

*1 VIN1 Application terminal: CNT, MUTE

*2 VIN2 Application terminal: IN1, IN2-1, IN2-2, IN3, IN4, BIAS, PRTC

*3 VOOUT1 Application terminal: PRTOOUT.

*4 VOOUT2 Application terminal: VREG.

*5 70mm×70mm×1.6mm, occupied copper foil is less than 3%, one layer substrate (back copper foil 0mm×0mm)
Reduce power by 8.8mW for each degree above 25°C

*6 70mm×70mm×1.6mm, occupied copper foil is less than 3%, four layer substrate (back copper foil 70mm×70mm)
Reduce power by 32.0mW for each degree above 25°C.

● Operating conditions (Ta=-40 to+85°C)

Parameters	Symbol	Min.	Typ.	Max.	Units
Pre-block power supply voltage	PowVCC1	4.5	8.0	10.0	V
Spindle driver power-block power supply voltage ^{*7}					
Loading/Sled driver power-block power supply voltage ^{*7}	PowVCC2	4.5	8.0	PowVCC1	V
Actuator system power supply ^{*7}					
Voltage difference between PowVCC1 and PowVCC2 (PowVCC1-PowVCC2)	DiffPowVCC	0	-	3.5	V

*7 Please decide the power supply voltage after considering power dissipation.

●Electrical Characteristics (Unless otherwise noted, Ta=25°C, PowVCC1=PowVCC2=8V, BIAS=1.65V, RL=8Ω)

Parameter	Symbol	Limits			Unit	Condition
		Min.	Typ.	Max.		
Quiescent Current	IQ	—	16	40	mA	At no-load, MUTE=High
< Driver >						
Output Offset (CH1,2)	VOOF1	-100	0	100	mV	
Output Offset (CH3,4)	VOOF2	-50	0	50	mV	
Maximum Output Amplitude (CH1)	VOM1	5.8	6.5	—	V	RON(total)=1.7Ω (Typ.) Equivalent
Maximum Output Amplitude (CH2)	VOM2	6.4	7.0	—	V	RON(total)=0.9Ω (Typ.) Equivalent
Maximum Output Amplitude(CH3,4)	VOM34	5.3	6.0	—	V	RON(total)=2.5Ω (Typ.) Equivalent
Closed Loop Gain (CH1,2)	GV12	24.0	25.7	27.4	dB	
Closed Loop Gain (CH3,4)	GV34	15.5	17.5	19.5	dB	
Input Impedance (CH1,2)	INRCH12	15	20.75	27	kΩ	
Input Impedance (CH3,4)	INRCH34	38	50	62	kΩ	
MUTE Low Level Voltage	VML	—	—	0.5	V	
MUTE High Level Voltage	VMH	2.0	—	—	V	
MUTE Input Current	IMUTE	32	52	74	μA	MUTE=3.3V
CNT Low Level Voltage	VCNTL	—	—	0.5	V	
CNT High Level Voltage	VCNTH	2.0	—	—	V	
CNT Input Current	ICNT	32	52	74	μA	CNT=3.3V
BIAS Drop Mute	VBD	0.5	0.7	0.9	V	
BIAS Input Current	IBD	32	52	74	μA	BIAS=1.65V
LDIN Voltage (SLED is input)	VLDIN	—	0.1	0.3	V	CNT=Low
Internal Bias Voltage	VBIN	1.53	1.65	1.77	V	CNT=High
UVLO Release Voltage	UVLOR	3.8	4.0	4.2	V	
UVLO Detection Voltage	UVLOD	3.6	3.8	4.0	V	
VREG Voltage	VREG	—	5.0	—	V	CVREG=0.1μF

●Electrical Characteristics (Unless otherwise noted, Ta=25°C, PowVCC1=PowVCC2=8V, BIAS=1.65V, RL=8Ω)

Parameter	Symbol	Limits			Unit	Condition
		Min.	Typ.	Max.		
< Focus overcurrent protection function >						
PRTC Default Voltage	VPRTREF	—	0	0.3	V	At no-load
PRTC Protection Detection Voltage	VPRTDET	2.7	3.0	3.3	V	
PRTC Protection Release Voltage	VPRTOFF	0.7	1.0	1.3	V	
PRTOUT Low Output Voltage	VPOL	—	0.1	0.3	V	PRTOUT : 3.3V,33kΩ pullup
OCV Detection Current	IOCP	—	470	—	mA	
PRTC SINK Current	IPTCSINK	—	43	—	μA	PRTC=1V

●Electrical Characteristics (Ta=25°C, PowVCC1=PowVCC2=5V, BIAS=1.65V, RL=8Ω)

Parameter	Symbol	Limits			Unit	Condition
		Min.	Typ.	Max.		
Maximum Output Amplitude (CH1)	VOM1	3.7	4.1	—	V	RON(total)=1.7Ω (Typ.) Equivalent
Maximum Output Amplitude (CH2)	VOM2	4.1	4.5	—	V	RON(total)=0.9Ω (Typ.) Equivalent
Maximum Output Amplitude(CH3,4)	VOM34	3.4	3.8	—	V	RON(total)=2.5Ω (Typ.) Equivalent

●Electrical Characteristics (Unless otherwise noted, Ta=-40 to 85°C, PowVCC1=PowVCC2=8V, BIAS=1.65V, RL=8Ω)

Parameter	Symbol	Limits			Unit	Condition
		Min.	Typ.	Max.		
Quiescent Current	IQ	—	16	44	mA	At no-load, MUTE=High
< Driver >						
Output Offset (CH1,2)	VOOF1	-100	0	100	mV	
Output Offset (CH3,4)	VOOF2	-50	0	50	mV	
Maximum Output Amplitude (CH1)	VOM1	5.5	6.5	—	V	RON(total)=1.7Ω (Typ.) Equivalent
Maximum Output Amplitude (CH2)	VOM2	6.4	7.0	—	V	RON(total)=0.9Ω (Typ.) Equivalent
Maximum Output Amplitude(CH3,4)	VOM34	4.8	6.0	—	V	RON(total)=2.5Ω (Typ.) Equivalent
Closed Loop Gain (CH1,2)	GV12	24.0	25.7	27.4	dB	
Closed Loop Gain (CH3,4)	GV34	15.5	17.5	19.5	dB	
Input Impedance (CH1,2)	INRCH12	11	20.75	29	kΩ	
Input Impedance (CH3,4)	INRCH34	34	50	66	kΩ	
MUTE Low Level Voltage	VML	—	—	0.4	V	MUTE=3.3V
MUTE High Level Voltage	VMH	2.0	—	—	V	
MUTE Input Current	IMUTE	22	52	108	μA	
CNT Low Level Voltage	VCNTL	—	—	0.4	V	CNT=3.3V
CNT High Level Voltage	VCNTH	2.0	—	—	V	
CNT Input Current	ICNT	22	52	108	μA	BIAS=1.65V
BIAS Drop Mute	VBD	0.3	0.7	1.1	V	CNT=Low
BIAS Input Current	IBD	22	52	108	μA	CNT=High
LDIN Voltage (SLED is input)	VLDIN	—	0.1	0.3	V	
Internal Bias Voltage	VBIN	1.45	1.65	1.85	V	
UVLO Release Voltage	UVLOR	3.7	4.0	4.3	V	
UVLO Detection Voltage	UVLOD	3.5	3.8	4.1	V	
VREG Voltage	VREG	—	5.0	—	V	CVREG=0.1μF

●Electrical Characteristics (Unless otherwise noted, Ta=-40 to 85°C, PowVCC1=PowVCC2=8V, BIAS=1.65V, RL=8Ω)

Parameter	Symbol	Limits			Unit	Condition
		Min.	Typ.	Max.		
< Focus overcurrent protection function >						
PRTC Default Voltage	VPRTREF	—	0	0.3	V	At no-load
PRTC Protection Detection Voltage	VPRTDET	2.5	3.0	3.5	V	
PRTC Protection Release Voltage	VPRTOFF	0.5	1.0	1.5	V	
PRTOUT Low Output Voltage	VPOL	—	0.1	0.4	V	PRTOUT : 3.3V,33kΩ pullup
OCP Detection Current	IOCP	—	470	—	mA	
PRTC SINK Current	IPTCSINK	—	43	—	μA	PRTC=1V

●Electrical Characteristics (Unless otherwise noted, Ta=-40 to 85°C, PowVCC1=PowVCC2=5V, BIAS=1.65V, RL=8Ω)

Parameter	Symbol	Limits			Unit	Condition
		Min.	Typ.	Max.		
Maximum Output Amplitude (CH1)	VOM1	3.7	4.1	—	V	RON(total)=1.7Ω (Typ.) Equivalent
Maximum Output Amplitude (CH2)	VOM2	4.1	4.5	—	V	RON(total)=0.9Ω (Typ.) Equivalent
Maximum Output Amplitude(CH3,4)	VOM34	3.4	3.8	—	V	RON(total)=2.5Ω (Typ.) Equivalent

● Typical Performance Curves

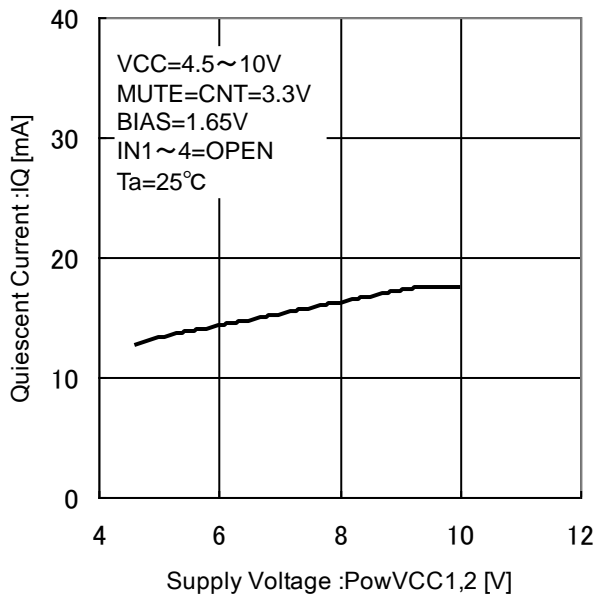

Figure 4. Quiescent Current

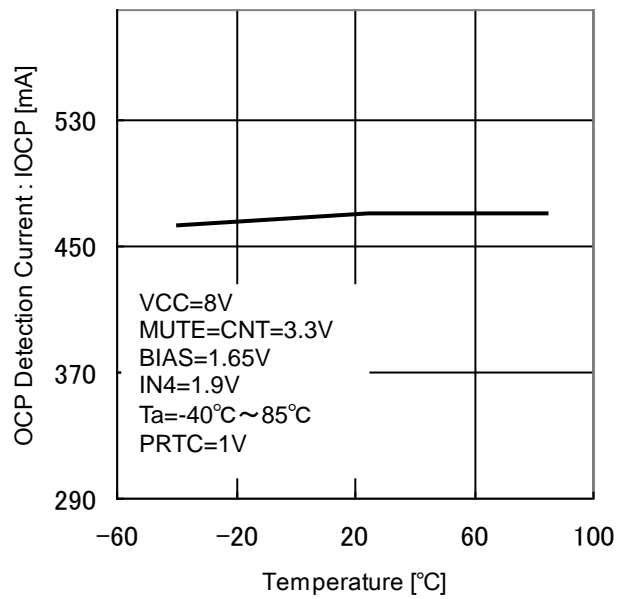

Figure 5. OCP Detection Current

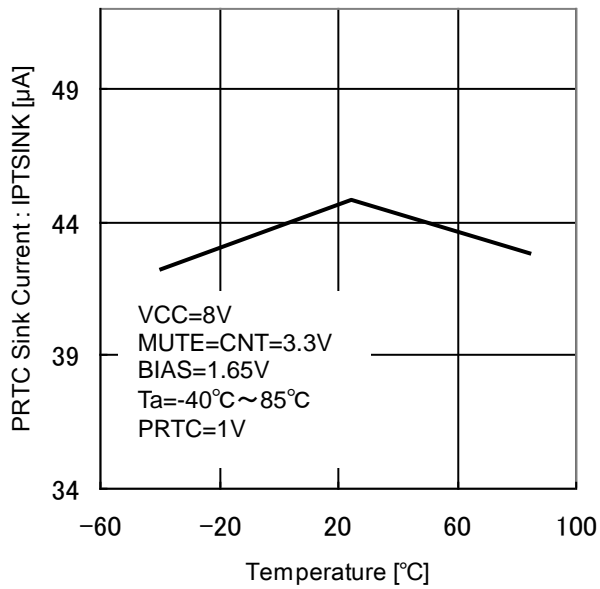

Figure 6. PRTC Sink Current

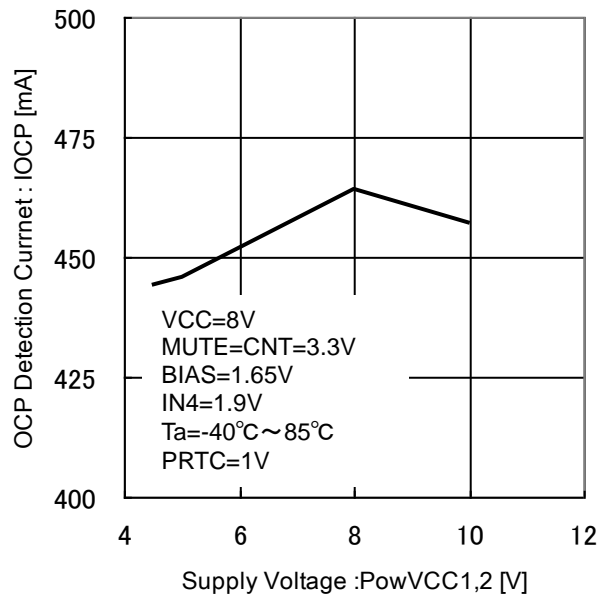

Figure 7. OCP Detection Current

● Typical Performance Curves

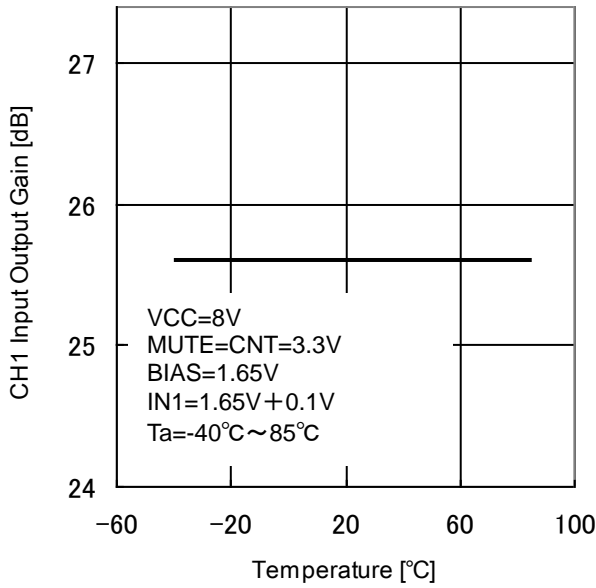

Figure 8. CH1 Closed Loop Gain

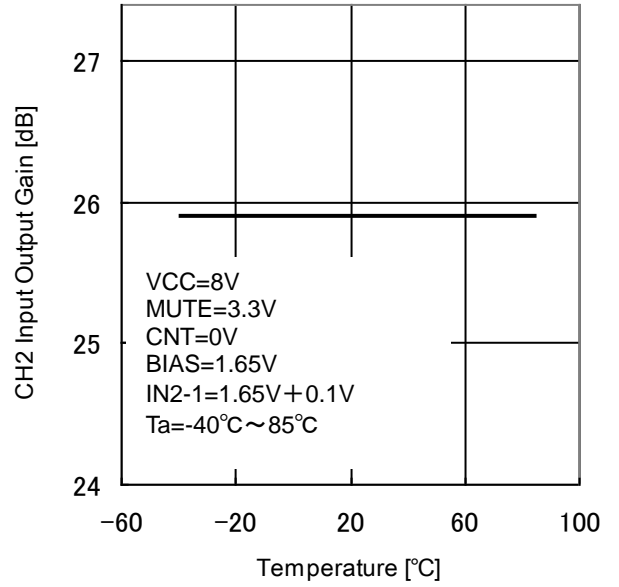

Figure 9. CH2 Closed Loop Gain

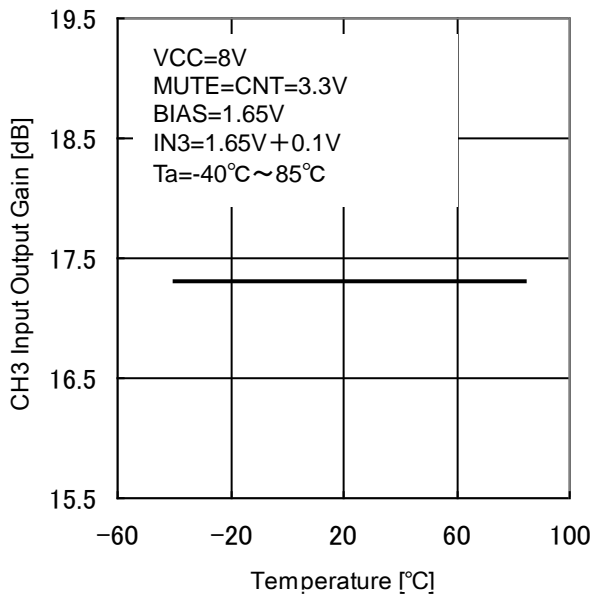

Figure 10. CH3 Closed Loop Gain

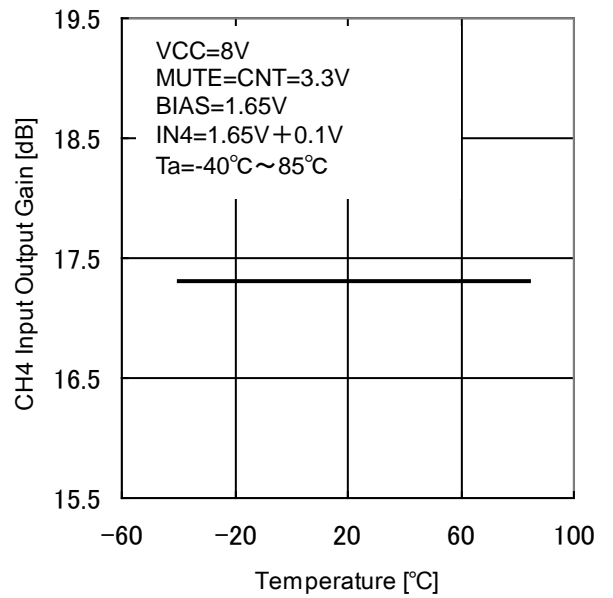

Figure 11. CH4 Closed Loop Gain

● Typical Performance Curves

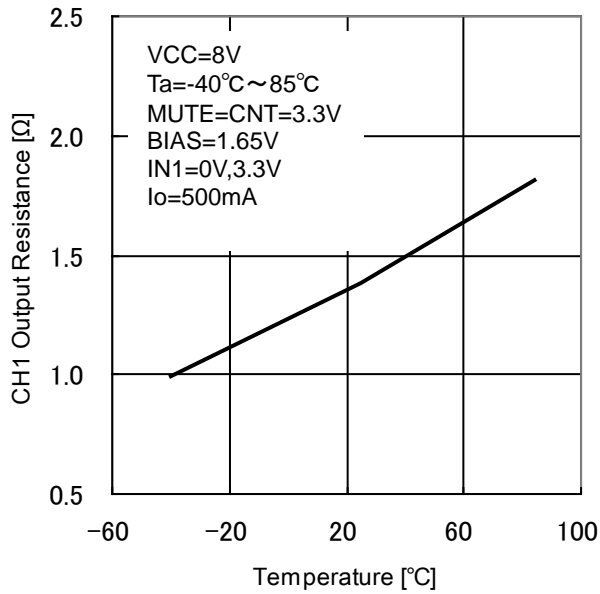

Figure 12. CH1 Output ON resistance characteristic

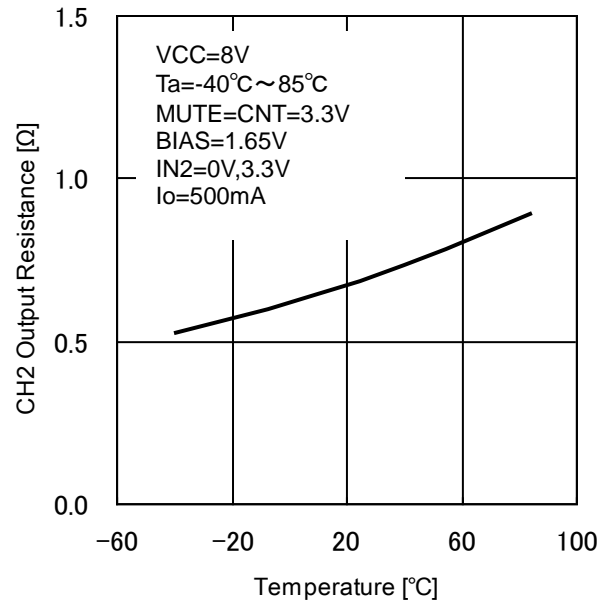

Figure 13. CH2 Output ON resistance characteristic

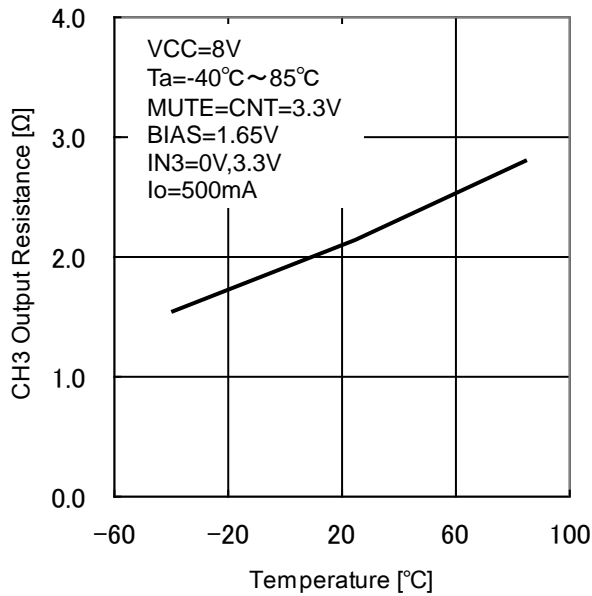

Figure 14. CH3 Output ON resistance characteristic

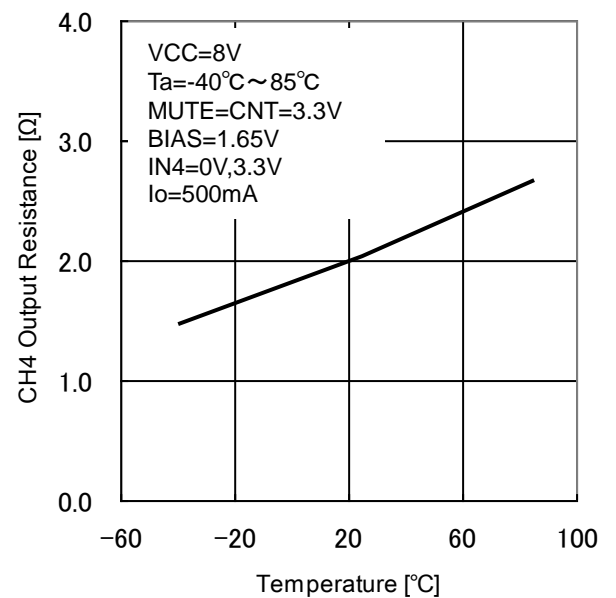

Figure 15. CH4 Output ON resistance characteristic

● Typical Performance Curves

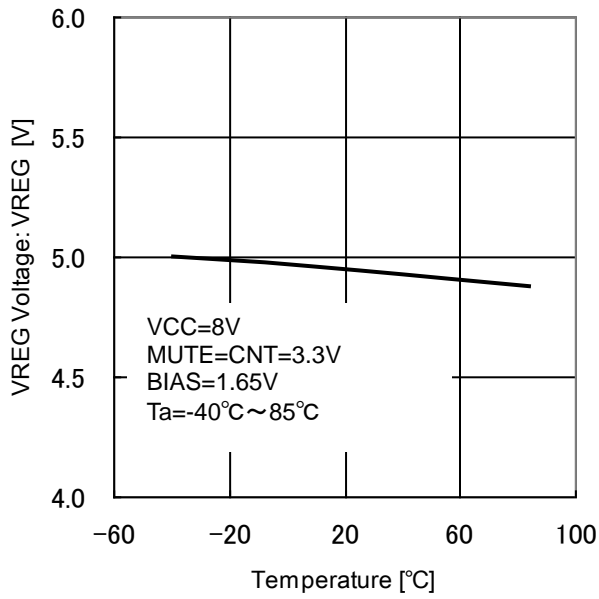

Figure 16. VREG Voltage

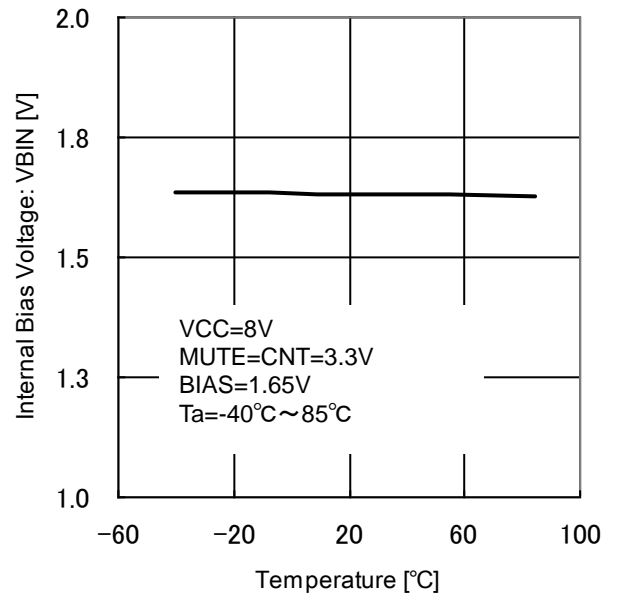

Figure 17. Internal Bias Voltage

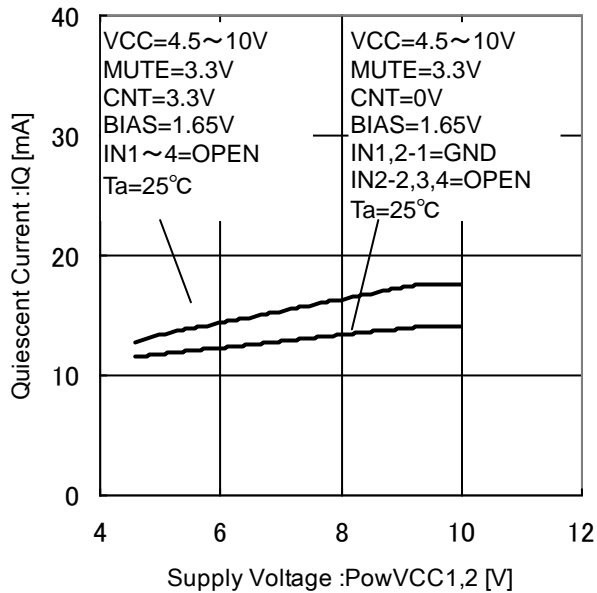

Figure 18. Quiescent Current at IN1~4=OPEN, Circuit Current at IN1=IN2-1=GND

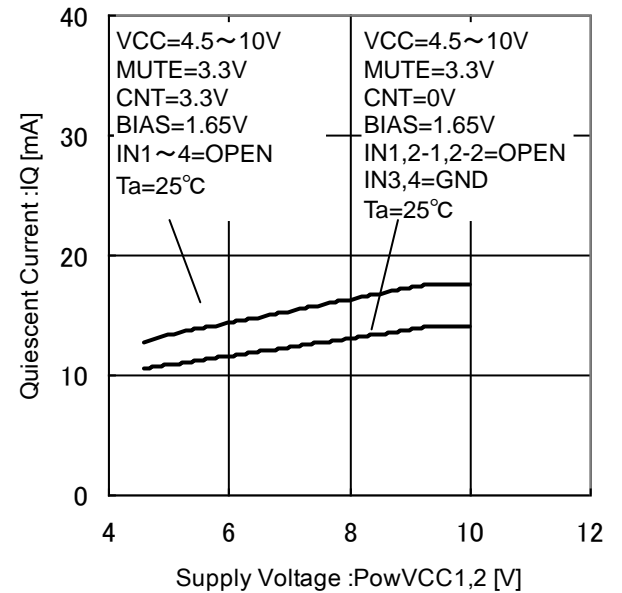

Figure 19. Quiescent Current at IN1~4=OPEN, Circuit Current at IN3=IN4=GND

● Operation description

- The driver can put the mute by switching the terminal MUTE and the terminal CNT to High level and Low level. The table below shows the logic.

▼ Driver logic (Normally operation)

State	Input			Output *8*9				
	MUTE	CNT	BIAS	CH1(SP)	CH2-1(SL)	CH2-2(LD)	CH3(TK)	CH4(FC)
1	H	H	H	Active	MUTE	Active	Active	Active
2	H	L	H	Active	Active	MUTE	Active	Active
3	L	H	H	MUTE	MUTE	Active	MUTE	MUTE
4	L	L	H	MUTE	MUTE	MUTE	MUTE	MUTE
5	H	H	L	MUTE	MUTE	Active	MUTE	MUTE
6	H	L	L	MUTE	MUTE	MUTE	MUTE	MUTE
7	L	H	L	MUTE	MUTE	Active	MUTE	MUTE
8	L	L	L	Hi-Z	Hi-Z	Hi-Z	Hi-Z	Hi-Z

▼ Driver logic (OCP Protected operation)

State	Input			Output *8*9				
	MUTE	CNT	BIAS	CH1(SP)	CH2-1(SL)	CH2-2(LD)	CH3(TK)	CH4(FC)
9	H	H	H	Active	MUTE	Active	MUTE	MUTE
10	H	L	H	Active	Active	MUTE	MUTE	MUTE
11	L	H	H	MUTE	MUTE	Active	MUTE	MUTE
12	L	L	H	MUTE	MUTE	MUTE	MUTE	MUTE
13	H	H	L	MUTE	MUTE	Active	MUTE	MUTE
14	H	L	L	MUTE	MUTE	MUTE	MUTE	MUTE
15	L	H	L	MUTE	MUTE	Active	MUTE	MUTE
16	L	L	L	Hi-Z	Hi-Z	Hi-Z	Hi-Z	Hi-Z

▼ Driver logic (UVLO,TSD Protected operation)

State	Input			Output *8*9				
	MUTE	CNT	BIAS	CH1(SP)	CH2-1(SL)	CH2-2(LD)	CH3(TK)	CH4(FC)
17	L	L	L	Hi-Z	Hi-Z	Hi-Z	Hi-Z	Hi-Z
18	The others state			MUTE	MUTE	MUTE	MUTE	MUTE

*8 MUTE : Both positive and negative output voltages become PowVCC/2.

*9 Hi-Z : Both positive and negative outputs become Hi-Z.

- BIAS drop mute function
BIAS terminal (Pin20) put the mute by 0.7V(Typ.) or less. Please make it to 1.3V or more in the normally operation.
- UVLO function
Output current put the mute when PowVCC1 voltage becomes 3.8V(Typ.) or less. The driver part circuit stands up when rising to 4.0V(typ.) again.
- Voltage reference(VREG)
5V (Typ.) is generated from the PowVCC1 input voltage. Connect a capacitor (CVREG = 0.1μF Typ.) to the VREG terminal for phase compensation. Operation may become unstable if CVREG is not connected.

5. Focus overcurrent protection function

It is a function to turn off the actuator output when detecting the FOCUS(CH4) over current state more than set time. When the load current that flows to FOCUS (CH4) output NMOS exceeds 470mA (Typ.), the current proportional to the load current value is charged to the capacitor. The time to protection is decided depending on the capacitor value connected with the terminal PRTC. The default value of the terminal PRTC is 0V (Typ.).

It protects with 3.0V (Typ.). (Please note that protection operates when the potential of 3.0V or more remains in the terminal PRTC when the power supply starts, and the standby is released. It is likely to protect when the power supply is started up in the slew rate of 1ms or less, and please start up the power supply in the slew rate of 1ms or more.)When the terminal PRTC is 1.0V (Typ.) or less, protection is released.

Please delete C of the terminal PRTC and short-circuited with GND when the overcurrent function unused.

PRTC	PRTOUT (OUTPUT)	CH3(TRAKING)Output CH4(FOCUS)Output
>3.0V	H	MUTE (Protection state)
<3.0V	L	Active

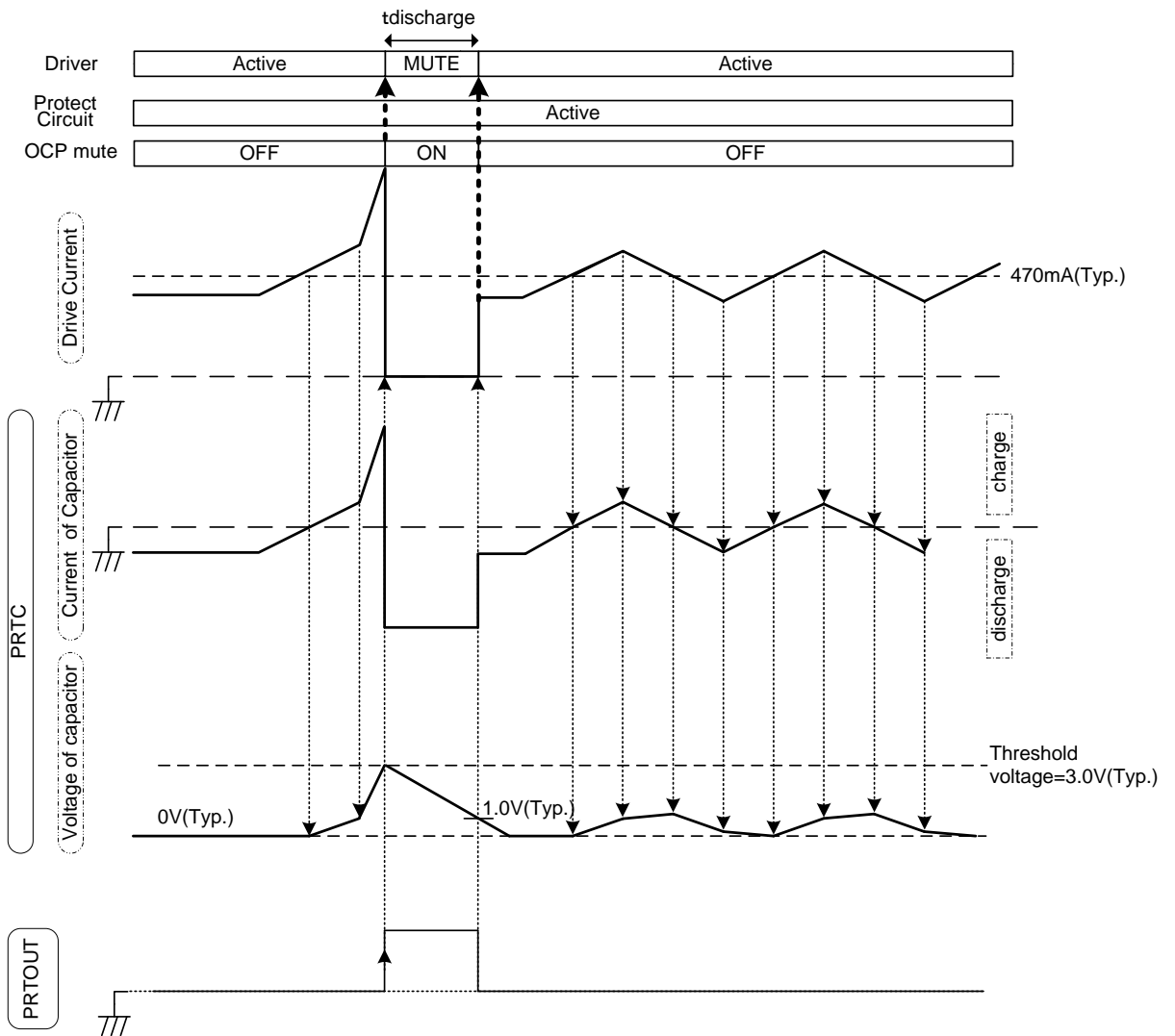

Figure 20. OCP Timing Chart

▼ Focus overcurrent protection circuit (OCP) setting

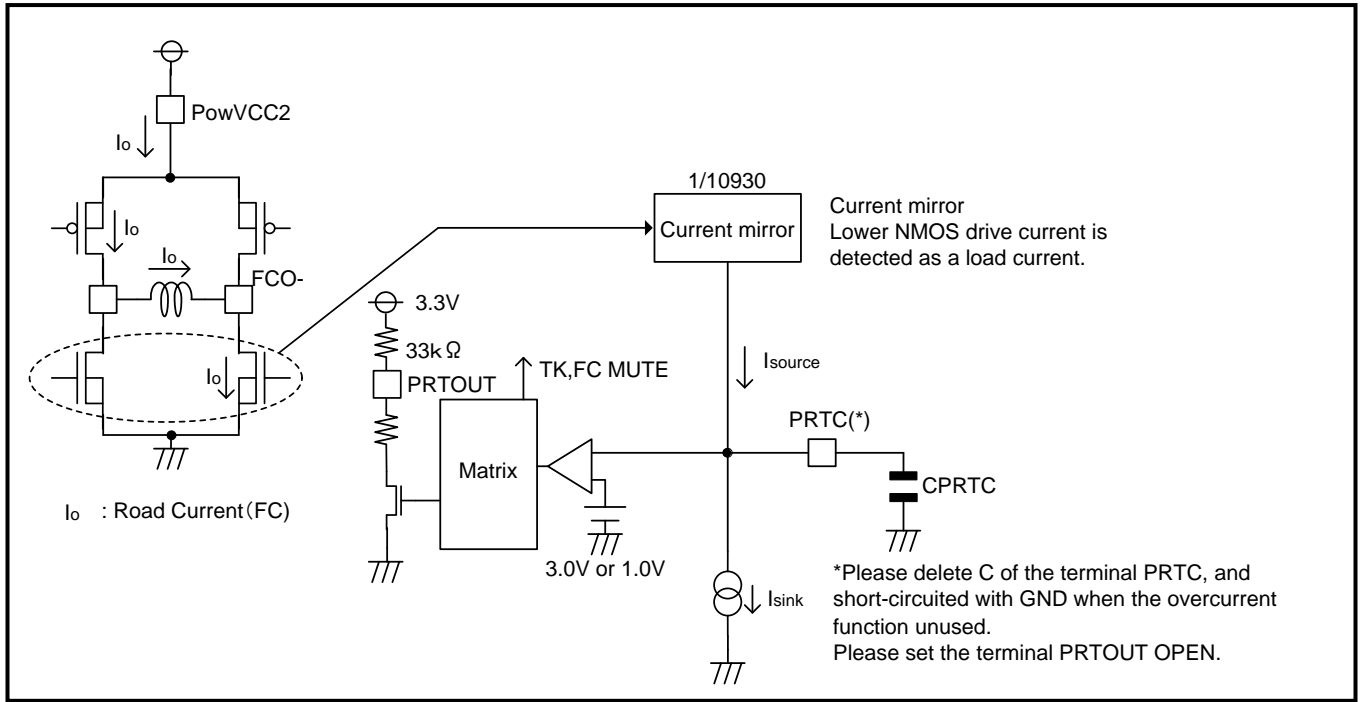

Figure 21. OCP Setting

PowVCC1=PowVCC2=8V, Ta=25°C

$$I_{sink} = 43\mu A(Typ.) \dots\dots ①$$

$$I_{source} = \frac{I_o}{10930} \dots\dots ②$$

Load current that begins to be detected I_t as over current (Threshold current) : $I_t = 43\mu A \times 10930 = 470mA(Typ.)$

Error detection flag output time $t_{detective}$: The charge is started to CPRTC reaches 3.0V from 0V, and the time to becoming PRTOUT =High.

$$CPRTC \times VRTDET = (I_{source} - I_{sink}) \times t_{detective} \quad (VRTDET = 3.0V(Typ.))$$

$$\therefore t_{detective} = \frac{CPRTC \times VRTDET}{I_{source} - I_{sink}}$$

$$\therefore t_{detective} = \frac{CPRTC \times VRTDET}{\frac{I_o}{10930} - 43\mu A} \dots\dots ③ (*: ①, ②)$$

When assuming $t_{detective} = 0.5s$, $I_o = 500mA$ as an example

$$③ \quad CPRTC = \frac{t_{detective}}{VRTDET} \times \left(\frac{I_o}{10930} - 43\mu A \right) = \frac{0.5s}{3.0V} \times \left(\frac{500mA}{10930} - 43\mu A \right) = 0.46\mu F$$

MUTE release time $t_{discharge}$: Electricity is discharged from CPRTC after it becomes PRTOUT =High and time until the PRTC voltage drops from 3.0V to 1.0V.

$$CPRTC \times (VRTDET - VRTOFF) = I_{sink} \times t_{discharge}$$

$$\therefore t_{discharge} = \frac{CPRTC \times (VRTDET - VRTOFF)}{I_{sink}}$$

$$\therefore t_{discharge} = \frac{0.46\mu A \times (3.0V - 1.0V)}{43\mu A} = 21ms$$

6. Output Amplitude calculation

P) SPINDLE,SLED/LOADING

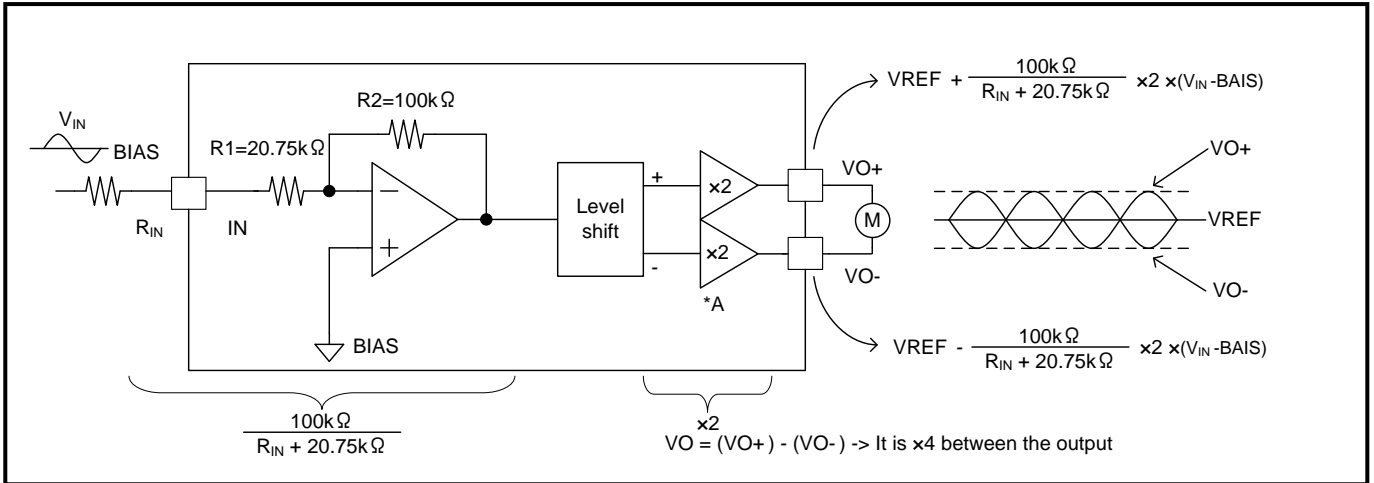

Figure 22. SPINDLE,SLED/LOADING Closed Loop Gain calculation

$$\text{Gain} = \frac{VO}{V_{IN}} = \frac{100k\Omega}{R_{IN} + 20.75k\Omega} \times 2 \times 2$$

Example $R_{IN} = 0k\Omega$

$$\text{Gain} = \frac{100k\Omega}{20.75k\Omega} \times 2 \times 2 = 25.7\text{dB}$$

*Please consider component dispersion

$R1 = 20.75k\Omega \pm 18\%$

$R2 = 100k\Omega \pm 18\%$

$R2/R1 = 4.82 \pm 2.5\%$

$*A = 2 \pm 18\%, 2 - 16\%$

ii) FOCUS,TACKING

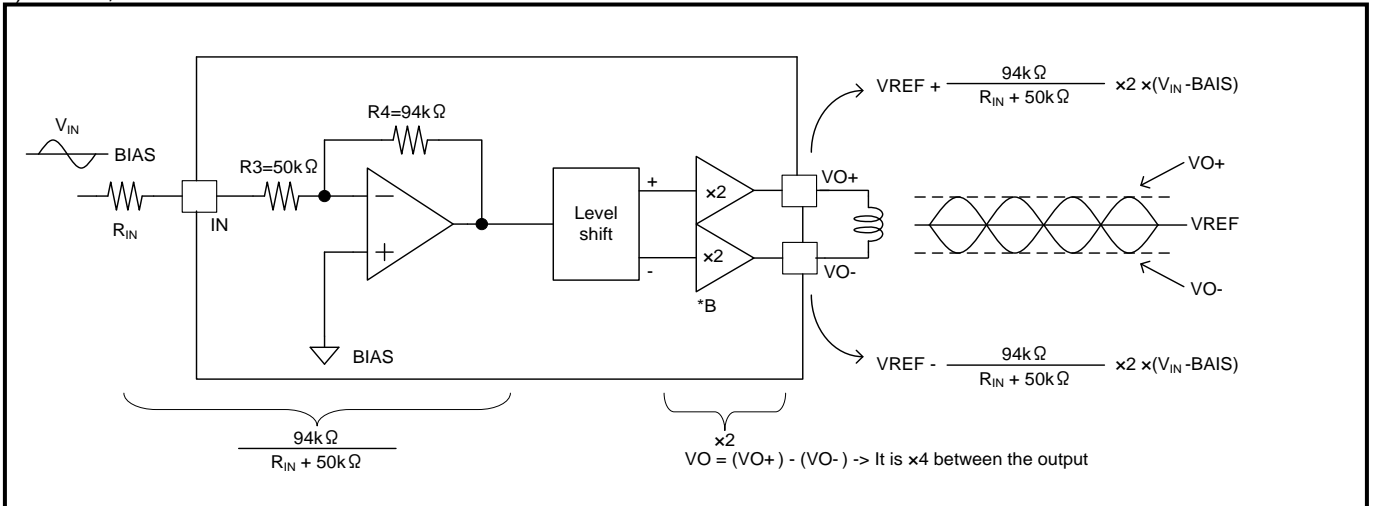

Figure 23. FOCUS, TRACKING Closed Loop Gain calculation

$$\text{Gain} = \frac{VO}{V_{IN}} = \frac{94k\Omega}{R_{IN} + 50k\Omega} \times 2 \times 2$$

Example $R_{IN} = 0k\Omega$

$$\text{Gain} = \frac{VO}{V_{IN}} = \frac{94k\Omega}{50k\Omega} \times 2 \times 2 = 17.5\text{dB}$$

*Please consider component dispersion

$R3 = 50k\Omega \pm 18\%$

$R4 = 94k\Omega \pm 18\%$

$R4/R3 = 1.88 \pm 2.5\%$

$*B = 2 \pm 22\%, 2 - 19\%$

● Typical Application Circuit

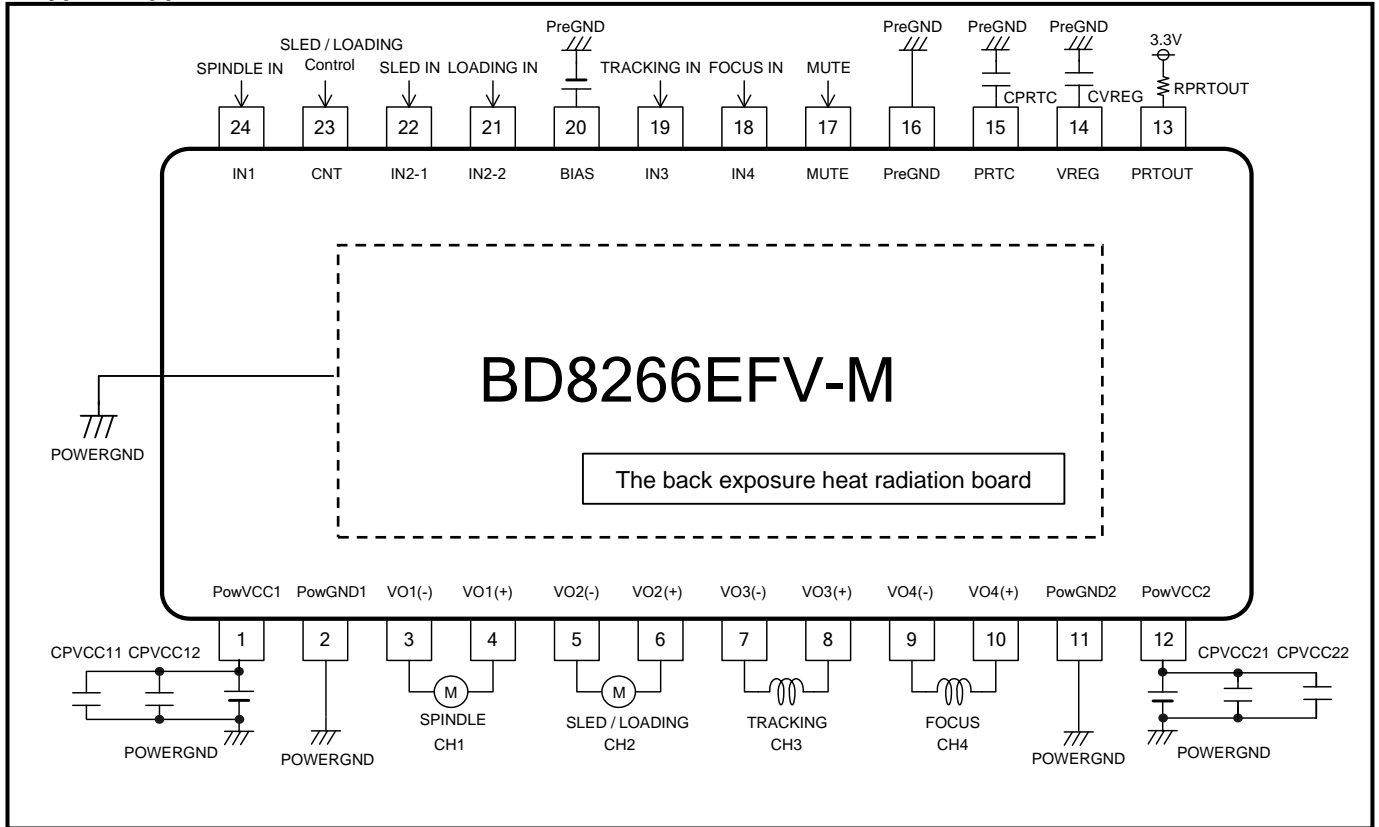

Figure 24. Typical Application Circuit Example

▼ Channel example

CH1	SPINDLE
CH2	SLED/LOADING
CH3	TRACKING
CH4	FOCUS

▼ External part list

Component name	Component value	Product name	Manufacturer
CPVCC11	0.1μF	GCM188R11H104KA42	murata
CPVCC12	47μF	UCD1E470MCL	Nichicon
CPVCC21	0.1μF	GCM188R11H104KA42	murata
CPVCC22	47μF	UCD1E470MCL	Nichicon
CPRTC	0.1μF~1μF	GCM188R11HxxxKA42	murata
CVREG	0.1μF	GCM188R11H104KA42	murata
RPRTOUT	33kΩ	MCR03 Series	Rohm

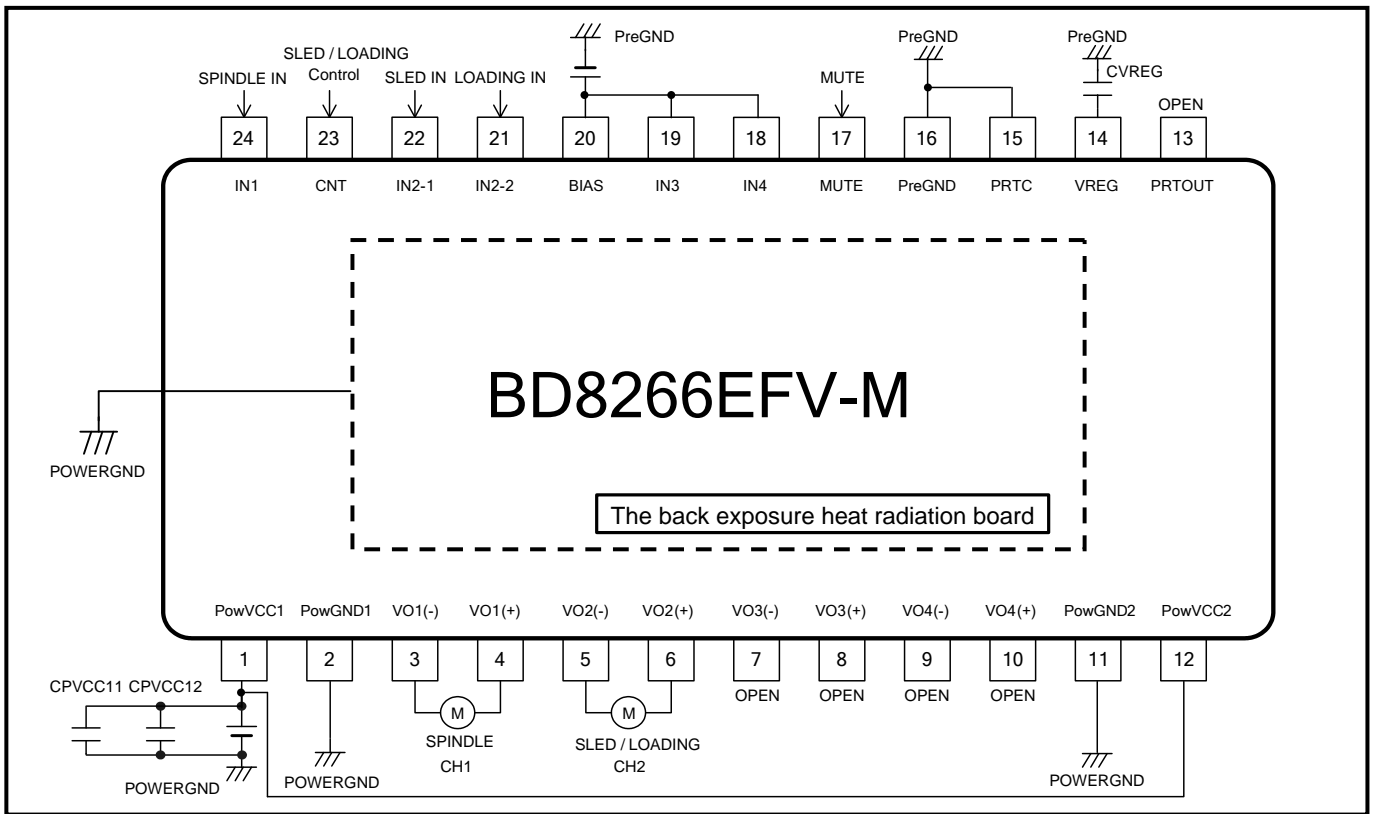

Figure 25. Application Circuit Example : CH1,CH2 are used, and CH3,CH4 are not used

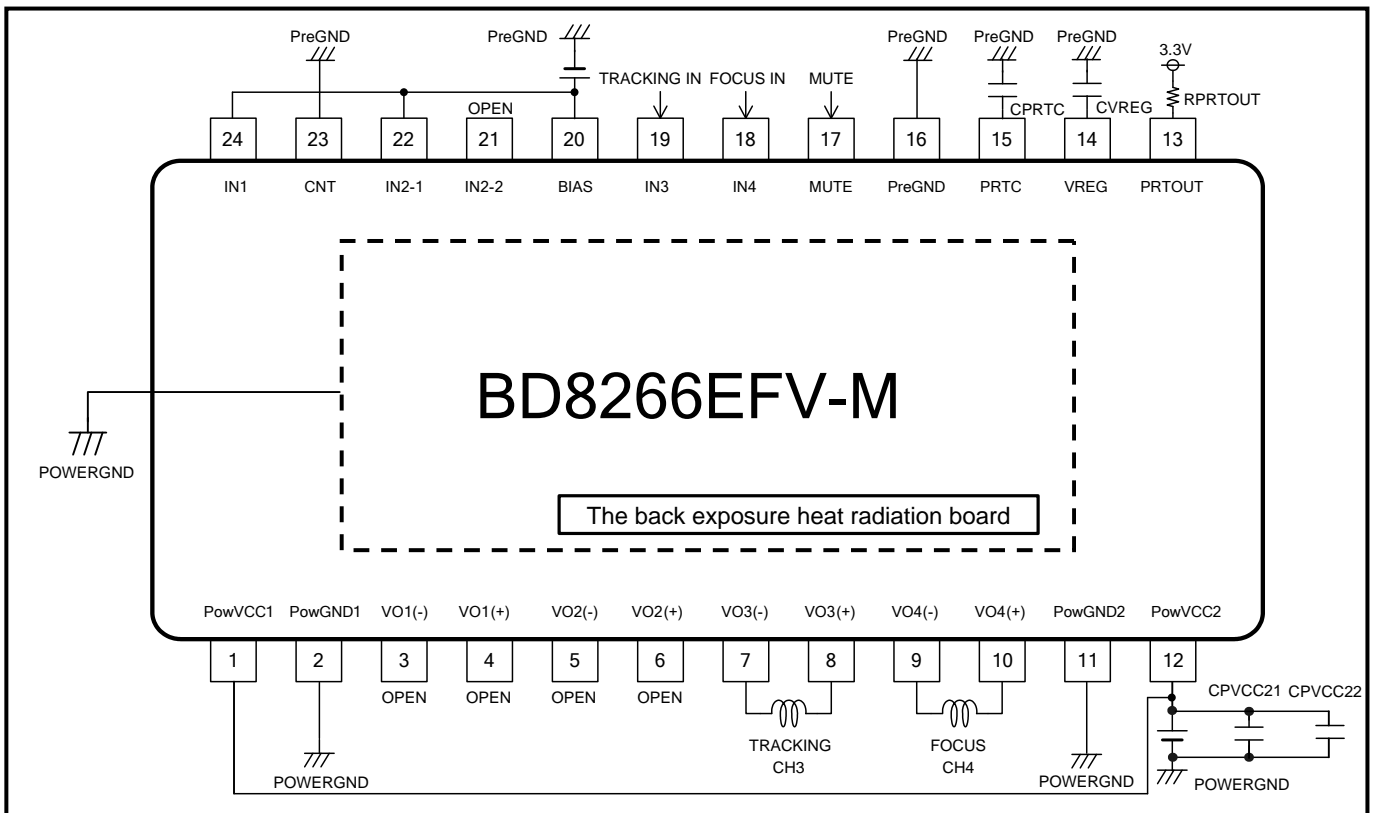

Figure 26. Application Circuit Example : CH1,CH2 are not used, and CH3,CH4 are used

● Power dissipation

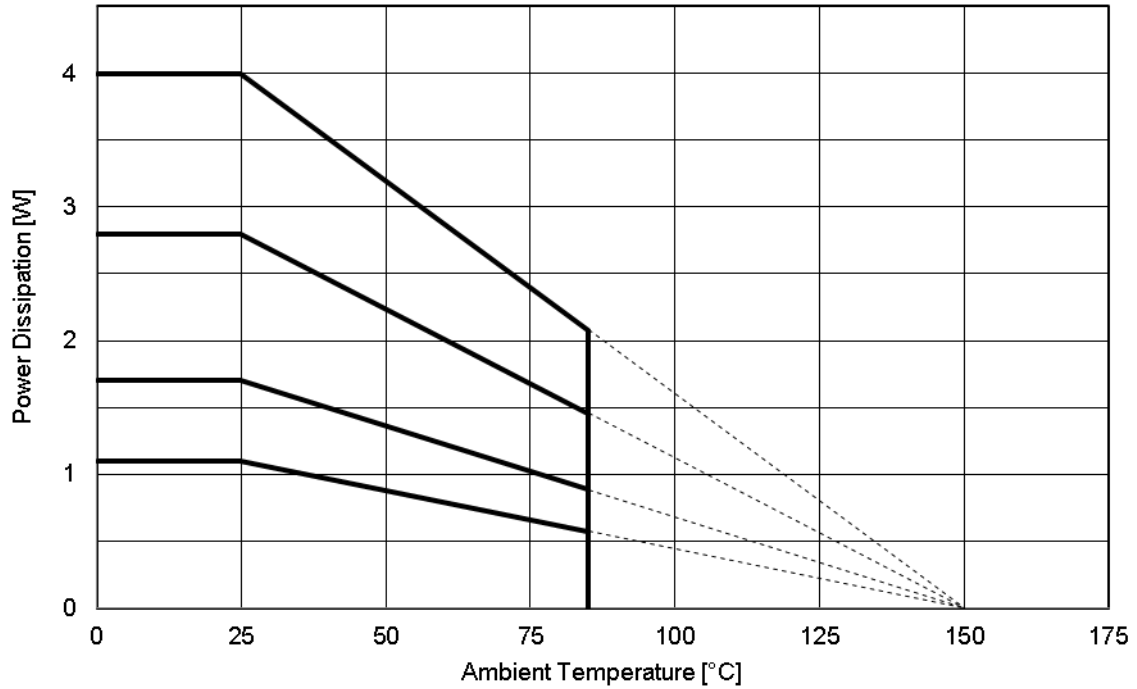

Figure 27. Power Dissipation

70mm×70mm×1.6mm, occupied copper foil is less than 3%, glass epoxy substrate,

The board and the back exposure heat radiation board part of package are connected with solder.

- Board (1) : 1 layer board (copper foil 0mm × 0mm)
- Board (2) : 2 layer board (copper foil 15mm × 15mm)
- Board (3) : 2 layer board (copper foil 70mm × 70mm)
- Board (4) : 4 layer board (copper foil 70mm × 70mm)

- Board (1) : $\theta_{ja} = 113.6 \text{ }^{\circ}\text{C/W}$
- Board (2) : $\theta_{ja} = 73.5 \text{ }^{\circ}\text{C/W}$
- Board (3) : $\theta_{ja} = 44.6 \text{ }^{\circ}\text{C/W}$
- Board (4) : $\theta_{ja} = 31.3 \text{ }^{\circ}\text{C/W}$

Under Ambient Temperature is 85°C

- Board (1) : $P_d = 0.57\text{W}$
- Board (2) : $P_d = 0.88\text{W}$
- Board (3) : $P_d = 1.46\text{W}$
- Board (4) : $P_d = 2.08\text{W}$

CAUTION: P_d depends on number of the PCB layer and area.
This value is measurement value.

● I/O equivalence circuit

<p>3. VO1- 4. VO1+ 5. VO2- 6. VO2+</p>	<p>7. VO3- 8. VO3+ 9. VO4- 10. VO4+</p>	<p>13. PRTOUT</p>
<p>14. VREG</p>	<p>15. PRTC</p>	<p>17. MUTE</p>
<p>18. IN4 19. IN3</p>	<p>20. BIAS</p>	<p>21. IN2-2</p>
<p>23. CNT</p>	<p>22. IN2-1 24. IN1</p>	

※Values is typical .

●Operational Note

- 1) Absolute maximum ratings
We are careful enough for quality control about this IC. So, there is no problem under normal operation, excluding that it exceeds the absolute maximum ratings. However, this IC might be destroyed when the absolute maximum ratings, such as impressed voltages or the operating temperature range, is exceeded, and whether the destruction is short circuit mode or open circuit mode cannot be specified. Please take into consideration the physical countermeasures for safety, such as fusing, if a particular mode that exceeds the absolute maximum rating is assumed.
- 2) Reverse polarity connection
Connecting the power line to the IC in reverse polarity (from that recommended) will damage the part. Please utilize the direction protection device as a diode in the supply line and motor coil line. Power supply line
- 3) Power supply Line
Due to return of regenerative current by reverse electromotive force, using electrolytic and ceramic suppress filter capacitors (0.1 μ F) close to the IC power input terminals (electric power supply and GND) are recommended. Please note the electrolytic capacitor value decreases at lower temperatures and examine to dispense physical measures for safety. And, for ICs with more than one power supply, it is possible that rush current may flow instantaneously due to the internal powering sequence and delays. Therefore, give special consideration to power coupling capacitance, power wiring, width of GND wiring, and routing of wiring.
- 4) GND line
Please keep the GND line the lowest potential always, and check the GND voltage when transient voltages are connected to the IC.
- 5) Thermal design
Do not exceed the power dissipation (Pd) of the package specification rating under actual operation, and please design enough temperature margins. This product has exposed the frame to the back side of the package, but please note that it is assumed to use heat radiation efficiency by the heat radiation for this part. Please take the heat radiation pattern on not only the surface of the substrate but also the back of the substrate widely.
- 6) Short circuit mode between terminals and wrong mounting
Do not mount the IC in the wrong direction and displacement, and be careful about the reverse-connection of the power connector. Moreover, this IC might be destroyed when the dust short the terminals between them or GND.
- 7) Radiation
Strong electromagnetic radiation can cause operation failures.
- 8) ASO (Area of Safety Operation)
Do not exceed the maximum ASO and the absolute maximum ratings of the output driver.
- 9) TSD (Thermal Shut-Down)
The TSD is activated when the junction temperature (Tj) exceeds 175°C, and the output terminal is switched to OPEN. This protection have 25°C(Typ.) hysteresis. The guarantee and protection of set are not purpose. Therefore, please do not use this IC after TSD circuit operates, nor use it for assumption that operates the TSD circuit.
- 10) Capacitor between output driver and GND
If a large capacitor is connected between the output driver and GND, this IC might be destroyed when Vcc becomes 0V or GND, because the electric charge accumulated in the capacitor flows to the output driver. Please set said capacitor to smaller than 0.1 μ F.
- 11) Inspection by the set circuit board
The stress might hang to IC by connecting the capacitor to the terminal with low impedance. Then, please discharge electricity in each and all process. Moreover, when attaching or detaching from jig in the inspection process, please turn off the power before mounting the IC, and turn on after mounting the IC, and vice versa. In addition, please take into consideration the countermeasures for electrostatic damage, such as giving the earth in assembly process, transportation or preservation.

12) Input terminal

This IC is a monolithic IC, and has P⁺ isolation and P substrate for the element separation. Therefore, a parasitic PN junction is formed in this P-layer and N-layer of each element. For instance, the resistor or the transistor is connected to the terminal as shown in the figure below. When the GND voltage potential is greater than the voltage potential at Terminal A on the resistor, at Terminal B on the transistor, the PN junction operates as a parasitic diode. In addition, the parasitic NPN transistor is formed in said parasitic diode and the N layer of surrounding elements close to said parasitic diode. These parasitic elements are formed in the IC because of the voltage relation. The parasitic element operating causes the interference of circuit operation, then the wrong operation and destruction. Therefore, please be careful so as not to operate the parasitic elements by impressing to input terminals lower voltage than GND (P substrate). Please do not apply the voltage to the input terminal when the power-supply voltage is not impressed. Moreover, please impress each input terminal lower than the power-supply voltage or equal to the specified range in the guaranteed voltage when the power-supply voltage is impressing.

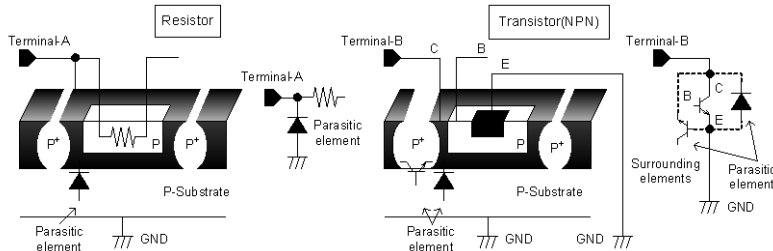

Figure 28. Example of IC Structure

13) Earth wiring pattern

If small signal GND and large current GND exist, disperse their pattern. In addition, for voltage change by pattern wiring impedance and large current not to change voltage of small signal GND, each ground terminal of IC must be connected at the one point on the set circuit board. As for GND of external parts, it is similar to the above-mentioned.

● Ordering Information

B	D	8	2	6	6	E	F	V	-	M	E	2
---	---	---	---	---	---	---	---	---	---	---	---	---

Part Number	Package EFV: HTSSOP-B24	Packaging M: high reliability E2: Embossed carrier tape (HTSSOP-B24)
-------------	----------------------------	--

● Physical Dimension Tape and Reel Information

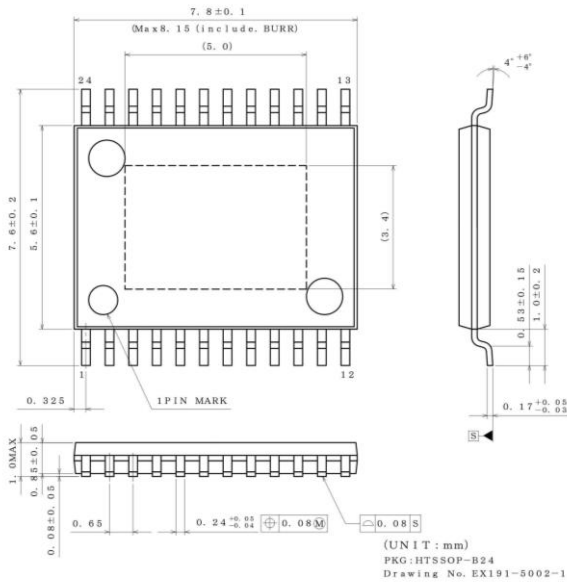

<Tape and Reel information>	
Tape	Embossed carrier tape (with dry pack)
Quantity	2000pcs
Direction of feed	E2 (The direction is the 1pin of product is at the upper left when you hold reel on the left hand and you pull out the tape on the right hand)

● Marking Diagram (TOP VIEW)

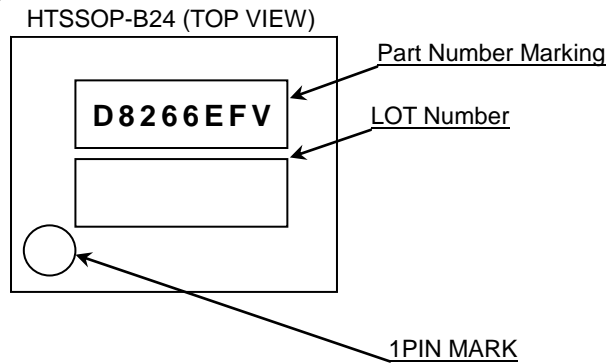

●Revision History

Date	Revision	Changes
30.May.2012	001	New Release
30.Aug.2012	005	<p>Page addition P6-7 Electrical Characteristic for -40°C to 85°C P8-11 Typical Performance Curves P15 Gain calculation</p> <p>Revise P1 Typical Application Circuit P2 Pin Description & Block Diagram P4 Term addition in Electrical Characteristic(s) P5 Term addition in Electrical Characteristic(s) P12 Additional table for Driver logic (OPU Protected operation) P12 VREG explanation P13-14 Constant symbol P16 Block Diagram P16 Table addition for Channel example and External constant P17 Power dissipation at 85°C P22 Revision History</p>
8.Nov.2012	006	<p>Revise Input resistant (IN1,IN2-1,IN2-2)21kΩ -> 20.75 kΩ Input resistant (IN3,IN4)47kΩ -> 50kΩ</p> <p>P4,P6 Symbol of BIAS Input Current change VBD ->IBD P14 Equation ③ unit change μA -> μF P15 Revise equation VO of Figure 20. And Figure 21. P16 External part list change P20 VCC-> electric power supply and add T.S.D explanation</p> <p>Change Symbol 'H' ->High 'L' ->Low u ->μ typ. ->Typ.</p>
13.Jun.2013	007	Revise P.21 Physical Dimension
27.Aug.2013	008	Revise P.12 Change the name OPU -> OCP P.14 Add the parenthesis and CPRTC in the calculation.
24.Apr.2014	009	Revise P.1 Add the sentence of AEC-Q100 Qualified at the features P.20 Delete the sentence of status of this document
17.Aug.2016	010	Revise P.3 Add DiffPowVCC at operating conditions P.11 Add Figure18, 19 P.17 Add Figure25, 26 Update of figure number Correction of other errors

Notice

Precaution on using ROHM Products

1. If you intend to use our Products in devices requiring extremely high reliability (such as medical equipment ^(Note 1), aircraft/spacecraft, nuclear power controllers, etc.) and whose malfunction or failure may cause loss of human life, bodily injury or serious damage to property ("Specific Applications"), please consult with the ROHM sales representative in advance. Unless otherwise agreed in writing by ROHM in advance, ROHM shall not be in any way responsible or liable for any damages, expenses or losses incurred by you or third parties arising from the use of any ROHM's Products for Specific Applications.

(Note1) Medical Equipment Classification of the Specific Applications

JAPAN	USA	EU	CHINA
CLASS III	CLASS III	CLASS II b	CLASS III
CLASS IV		CLASS III	

2. ROHM designs and manufactures its Products subject to strict quality control system. However, semiconductor products can fail or malfunction at a certain rate. Please be sure to implement, at your own responsibilities, adequate safety measures including but not limited to fail-safe design against the physical injury, damage to any property, which a failure or malfunction of our Products may cause. The following are examples of safety measures:
 - [a] Installation of protection circuits or other protective devices to improve system safety
 - [b] Installation of redundant circuits to reduce the impact of single or multiple circuit failure
3. Our Products are not designed under any special or extraordinary environments or conditions, as exemplified below. Accordingly, ROHM shall not be in any way responsible or liable for any damages, expenses or losses arising from the use of any ROHM's Products under any special or extraordinary environments or conditions. If you intend to use our Products under any special or extraordinary environments or conditions (as exemplified below), your independent verification and confirmation of product performance, reliability, etc. prior to use, must be necessary:
 - [a] Use of our Products in any types of liquid, including water, oils, chemicals, and organic solvents
 - [b] Use of our Products outdoors or in places where the Products are exposed to direct sunlight or dust
 - [c] Use of our Products in places where the Products are exposed to sea wind or corrosive gases, including Cl₂, H₂S, NH₃, SO₂, and NO₂
 - [d] Use of our Products in places where the Products are exposed to static electricity or electromagnetic waves
 - [e] Use of our Products in proximity to heat-producing components, plastic cords, or other flammable items
 - [f] Sealing or coating our Products with resin or other coating materials
 - [g] Use of our Products without cleaning residue of flux (even if you use no-clean type fluxes, cleaning residue of flux is recommended); or Washing our Products by using water or water-soluble cleaning agents for cleaning residue after soldering
 - [h] Use of the Products in places subject to dew condensation
4. The Products are not subject to radiation-proof design.
5. Please verify and confirm characteristics of the final or mounted products in using the Products.
6. In particular, if a transient load (a large amount of load applied in a short period of time, such as pulse. is applied, confirmation of performance characteristics after on-board mounting is strongly recommended. Avoid applying power exceeding normal rated power; exceeding the power rating under steady-state loading condition may negatively affect product performance and reliability.
7. De-rate Power Dissipation depending on ambient temperature. When used in sealed area, confirm that it is the use in the range that does not exceed the maximum junction temperature.
8. Confirm that operation temperature is within the specified range described in the product specification.
9. ROHM shall not be in any way responsible or liable for failure induced under deviant condition from what is defined in this document.

Precaution for Mounting / Circuit board design

1. When a highly active halogenous (chlorine, bromine, etc.) flux is used, the residue of flux may negatively affect product performance and reliability.
2. In principle, the reflow soldering method must be used on a surface-mount products, the flow soldering method must be used on a through hole mount products. If the flow soldering method is preferred on a surface-mount products, please consult with the ROHM representative in advance.

For details, please refer to ROHM Mounting specification

Precautions Regarding Application Examples and External Circuits

1. If change is made to the constant of an external circuit, please allow a sufficient margin considering variations of the characteristics of the Products and external components, including transient characteristics, as well as static characteristics.
2. You agree that application notes, reference designs, and associated data and information contained in this document are presented only as guidance for Products use. Therefore, in case you use such information, you are solely responsible for it and you must exercise your own independent verification and judgment in the use of such information contained in this document. ROHM shall not be in any way responsible or liable for any damages, expenses or losses incurred by you or third parties arising from the use of such information.

Precaution for Electrostatic

This Product is electrostatic sensitive product, which may be damaged due to electrostatic discharge. Please take proper caution in your manufacturing process and storage so that voltage exceeding the Products maximum rating will not be applied to Products. Please take special care under dry condition (e.g. Grounding of human body / equipment / solder iron, isolation from charged objects, setting of Ionizer, friction prevention and temperature / humidity control).

Precaution for Storage / Transportation

1. Product performance and soldered connections may deteriorate if the Products are stored in the places where:
 - [a] the Products are exposed to sea winds or corrosive gases, including Cl₂, H₂S, NH₃, SO₂, and NO₂
 - [b] the temperature or humidity exceeds those recommended by ROHM
 - [c] the Products are exposed to direct sunshine or condensation
 - [d] the Products are exposed to high Electrostatic
2. Even under ROHM recommended storage condition, solderability of products out of recommended storage time period may be degraded. It is strongly recommended to confirm solderability before using Products of which storage time is exceeding the recommended storage time period.
3. Store / transport cartons in the correct direction, which is indicated on a carton with a symbol. Otherwise bent leads may occur due to excessive stress applied when dropping of a carton.
4. Use Products within the specified time after opening a humidity barrier bag. Baking is required before using Products of which storage time is exceeding the recommended storage time period.

Precaution for Product Label

A two-dimensional barcode printed on ROHM Products label is for ROHM's internal use only.

Precaution for Disposition

When disposing Products please dispose them properly using an authorized industry waste company.

Precaution for Foreign Exchange and Foreign Trade act

Since concerned goods might be fallen under listed items of export control prescribed by Foreign exchange and Foreign trade act, please consult with ROHM in case of export.

Precaution Regarding Intellectual Property Rights

1. All information and data including but not limited to application example contained in this document is for reference only. ROHM does not warrant that foregoing information or data will not infringe any intellectual property rights or any other rights of any third party regarding such information or data.
2. ROHM shall not have any obligations where the claims, actions or demands arising from the combination of the Products with other articles such as components, circuits, systems or external equipment (including software).
3. No license, expressly or implied, is granted hereby under any intellectual property rights or other rights of ROHM or any third parties with respect to the Products or the information contained in this document. Provided, however, that ROHM will not assert its intellectual property rights or other rights against you or your customers to the extent necessary to manufacture or sell products containing the Products, subject to the terms and conditions herein.

Other Precaution



1. This document may not be reprinted or reproduced, in whole or in part, without prior written consent of ROHM.
2. The Products may not be disassembled, converted, modified, reproduced or otherwise changed without prior written consent of ROHM.
3. In no event shall you use in any way whatsoever the Products and the related technical information contained in the Products or this document for any military purposes, including but not limited to, the development of mass-destruction weapons.
4. The proper names of companies or products described in this document are trademarks or registered trademarks of ROHM, its affiliated companies or third parties.

General Precaution

1. Before you use our Products, you are requested to carefully read this document and fully understand its contents. ROHM shall not be in any way responsible or liable for failure, malfunction or accident arising from the use of any ROHM's Products against warning, caution or note contained in this document.
2. All information contained in this document is current as of the issuing date and subject to change without any prior notice. Before purchasing or using ROHM's Products, please confirm the latest information with a ROHM sales representative.
3. The information contained in this document is provided on an "as is" basis and ROHM does not warrant that all information contained in this document is accurate and/or error-free. ROHM shall not be in any way responsible or liable for any damages, expenses or losses incurred by you or third parties resulting from inaccuracy or errors of or concerning such information.

Looking for pricing, stock, or lifecycle information?

Click below to explore more details on WIN SOURCE:

-  [View BD8266EFV-ME2 on WIN SOURCE](#)
-  [Rohm Semiconductor](#) Information

Optimize Your Supply Chain with WIN SOURCE Solutions

-  Global Sourcing Solution
-  Obsolete Management
-  Cost Control Management
-  Shortage Management
-  Alternative Solution
-  Excess Inventory Management